

# INTERNATIONAL STANDARD



**Electromagnetic compatibility (EMC) –  
Part 5-6: Installation and mitigation guidelines – Mitigation of external EM  
influences**

IECNORM.COM : Click to view the full PDF of IEC 61000-5-6:2024



**THIS PUBLICATION IS COPYRIGHT PROTECTED**  
**Copyright © 2024 IEC, Geneva, Switzerland**

All rights reserved. Unless otherwise specified, no part of this publication may be reproduced or utilized in any form or by any means, electronic or mechanical, including photocopying and microfilm, without permission in writing from either IEC or IEC's member National Committee in the country of the requester. If you have any questions about IEC copyright or have an enquiry about obtaining additional rights to this publication, please contact the address below or your local IEC member National Committee for further information.

IEC Secretariat  
3, rue de Varembe  
CH-1211 Geneva 20  
Switzerland

Tel.: +41 22 919 02 11  
[info@iec.ch](mailto:info@iec.ch)  
[www.iec.ch](http://www.iec.ch)

**About the IEC**

The International Electrotechnical Commission (IEC) is the leading global organization that prepares and publishes International Standards for all electrical, electronic and related technologies.

**About IEC publications**

The technical content of IEC publications is kept under constant review by the IEC. Please make sure that you have the latest edition, a corrigendum or an amendment might have been published.

**IEC publications search - [webstore.iec.ch/advsearchform](http://webstore.iec.ch/advsearchform)**

The advanced search enables to find IEC publications by a variety of criteria (reference number, text, technical committee, ...). It also gives information on projects, replaced and withdrawn publications.

**IEC Just Published - [webstore.iec.ch/justpublished](http://webstore.iec.ch/justpublished)**

Stay up to date on all new IEC publications. Just Published details all new publications released. Available online and once a month by email.

**IEC Customer Service Centre - [webstore.iec.ch/csc](http://webstore.iec.ch/csc)**

If you wish to give us your feedback on this publication or need further assistance, please contact the Customer Service Centre: [sales@iec.ch](mailto:sales@iec.ch).

**IEC Products & Services Portal - [products.iec.ch](http://products.iec.ch)**

Discover our powerful search engine and read freely all the publications previews, graphical symbols and the glossary. With a subscription you will always have access to up to date content tailored to your needs.

**Electropedia - [www.electropedia.org](http://www.electropedia.org)**

The world's leading online dictionary on electrotechnology, containing more than 22 500 terminological entries in English and French, with equivalent terms in 25 additional languages. Also known as the International Electrotechnical Vocabulary (IEV) online.

IECNORM.COM : Click to view the full text of IEC 6100-56:2024

# INTERNATIONAL STANDARD



**Electromagnetic compatibility (EMC) –  
Part 5-6: Installation and mitigation guidelines – Mitigation of external EM  
influences**

INTERNATIONAL  
ELECTROTECHNICAL  
COMMISSION

ICS 33.100.01

ISBN 978-2-8322-8687-6

**Warning! Make sure that you obtained this publication from an authorized distributor.**

## CONTENTS

FOREWORD.....	6
INTRODUCTION.....	8
1 Scope.....	9
2 Normative references .....	9
3 Terms, definitions and abbreviated terms .....	9
3.1 Terms and definitions.....	9
3.2 Abbreviated terms.....	14
4 Overview and general considerations .....	14
4.1 Overview.....	14
4.2 General considerations .....	15
4.2.1 Elementary interference control .....	15
4.2.2 Shields and interfaces .....	15
5 Mitigation of radiated and conducted disturbances.....	17
5.1 Topological concepts .....	17
5.2 Mitigation needs.....	18
5.3 The general concept of enclosure .....	18
5.4 Interactions at the enclosure boundary.....	19
6 Shielding .....	19
6.1 General.....	19
6.2 Classification of protection zones.....	21
6.2.1 General .....	21
6.2.2 Zone 1 – Building shield .....	22
6.2.3 Zone 2 – Room shield.....	22
6.2.4 Zone 3 – Equipment shield .....	22
6.2.5 Zone 4 – Apparatus shield .....	22
6.3 Design principles for screening .....	22
6.3.1 General .....	22
6.3.2 Shielding effectiveness .....	23
6.3.3 Maintaining shielding effectiveness.....	23
6.4 Implementation of screening .....	25
6.4.1 General .....	25
6.4.2 Sensitive apparatus .....	25
6.4.3 Shielding of racks and chassis (zones 4/3 barrier) .....	25
6.4.4 Shielding of cabinets (zones 3/2 barrier).....	25
6.4.5 Shielding of rooms (zones 2/1 barrier) .....	25
6.4.6 Shielding of buildings (zones 1/0 barrier).....	26
6.4.7 Dealing with apertures .....	27
7 Filters.....	29
7.1 General.....	29
7.2 Fundamental filter characteristics.....	30
7.2.1 General .....	30
7.2.2 Attenuation and insertion loss.....	30
7.2.3 Basic types of filters .....	31
7.3 Functional tasks.....	32
7.4 Additional filtering concerns .....	33
7.4.1 Technical aspects .....	33

7.4.2	Economic aspects.....	33
7.5	Selection criteria.....	34
7.5.1	General.....	34
7.5.2	Voltage rating.....	34
7.5.3	Current rating.....	34
7.5.4	Duty-cycle and overload operating conditions.....	34
7.5.5	Operating frequency and range of frequencies to be filtered.....	35
7.5.6	Voltage drop and signal loss.....	35
7.5.7	Ambient temperature range.....	35
7.5.8	Insertion loss and attenuation.....	35
7.5.9	Withstand voltage.....	36
7.5.10	Attenuation of HF transient disturbances.....	36
7.5.11	Leakage current to protective earthing conductor.....	36
7.5.12	Permissible reactive current.....	37
7.6	Filter installation.....	37
7.6.1	General.....	37
7.6.2	Installation and mounting techniques.....	37
7.6.3	Wiring.....	38
7.6.4	Installation of cabinet filters.....	38
7.7	Filter testing.....	39
7.7.1	General considerations.....	39
7.7.2	Insulation to earth and withstand voltage of installed filters.....	40
7.7.3	Insertion loss.....	40
7.7.4	Attenuation of HF transient disturbances.....	40
8	Decoupling devices.....	41
8.1	Isolation transformers.....	41
8.2	Motor-generator sets.....	43
8.3	Engine generators.....	43
8.4	Uninterruptible power supply (UPS).....	43
8.5	Optical links.....	44
9	Surge-protective devices.....	44
9.1	General.....	44
9.2	Direct equipment protection.....	45
9.3	Installation of multiple SPDs.....	46
9.4	Side-effects of uncoordinated cascades.....	47
9.5	Typical protective devices.....	47
9.5.1	General.....	47
9.5.2	Voltage-limiting type SPDs.....	47
9.5.3	Voltage-switching type SPDs.....	47
Annex A (informative) Resilience-based approach for the mitigation of external high-power electromagnetic environments.....		48
A.1	Overview.....	48
A.2	The concept of resilience.....	48
A.2.1	General.....	48
A.2.2	Discussion on the protection-led approach.....	49
A.2.3	Benefits of a resilience-based approach.....	50
A.2.4	Affordability and risk.....	50
A.2.5	Appropriate application of a resilience-based approach.....	51
A.3	EM resilience model and framework.....	52

A.3.1	General .....	52
A.3.2	Identify function .....	52
A.3.3	Protect function .....	52
A.3.4	Detect function .....	53
A.3.5	Respond function.....	53
A.3.6	Recover function.....	53
A.3.7	Adaptation of the NIST framework to HPEM resilience.....	53
A.4	HPEM resilience framework implementation.....	53
A.4.1	Overview .....	53
A.4.2	Identify .....	53
A.4.3	Protect.....	55
A.4.4	Detect.....	60
A.4.5	Respond.....	68
A.4.6	Recover.....	69
A.5	Summary .....	69
	Bibliography.....	70
	Figure 1 – System barrier topology .....	15
	Figure 2 – Generalized system topology .....	17
	Figure 3 – Ports of an apparatus or facility.....	19
	Figure 4 – Topological concept of shields with interfaces at penetration points .....	20
	Figure 5 – Zones of protection of shielding and earthing systems .....	21
	Figure 6 – Example of performance of high-efficiency shielded enclosure .....	26
	Figure 7 – Honeycomb inserts for different cut-off frequencies.....	27
	Figure 8 – Typical screening attenuation of honeycomb inserts.....	28
	Figure 9 – Parameters for attenuation and insertion loss.....	30
	Figure 10 – Prevention of interference on installed equipment .....	32
	Figure 11 – Reduction of electromagnetic disturbances in the power network and the environment.....	32
	Figure 12 – Examples of insertion loss characteristics of AC/DC power port filters.....	36
	Figure 13 – Mounting of filters .....	38
	Figure 14 – Connection of screened cables .....	38
	Figure 15 – Example of integration of filters inside an equipment cabinet.....	39
	Figure 16 – Example of filter mounting in a dedicated unit .....	39
	Figure 17 – Laboratory measurement showing the propagation of a 0,5 $\mu$ s to 100 kHz ring wave, applied in differential mode, through an ordinary isolation transformer .....	41
	Figure 18 – Propagation of a 0,5 $\mu$ s to 100 kHz ring wave operating in the differential mode through a "line isolator" transformer .....	42
	Figure 19 – Inter-winding coupling in an isolation transformer .....	42
	Figure A.1 – Protection-led approach.....	49
	Figure A.2 – Resilience-based approach.....	49
	Figure A.3 – The five functions of the NIST cyber security framework .....	52
	Figure A.4 – Protection scheme utilising shielded cables and shielded cabinets .....	58
	Figure A.5 – IEMI detector developed by Fraunhofer INT, Germany.....	65
	Figure A.6 – TOTEM detector developed by QinetiQ Ltd., UK .....	66

Figure A.7 – Example of some HPEM events detected during a field-trial installation .....	67
Table 1 – Measured shielding effectiveness of a 2 m × 2 m cage made of concrete building armour, against a 20 ns rise-time pulse (equivalent frequency less than 20 MHz) .....	26
Table A.1 – Protection levels based on operational criticality .....	50
Table A.2 – Appropriate application of the resilience-based approach .....	51
Table A.3 – Identify function of the HPEM resilience framework .....	54
Table A.4 – Protect function of the HPEM resilience framework .....	56
Table A.5 – Detect function of the HPEM resilience framework .....	60
Table A.6 – Some advantages and limitations of different technologies for HPEM detection applications .....	63
Table A.7 – Respond function of the HPEM resilience framework .....	68
Table A.8 – Recover function of the HPEM resilience framework .....	69

IECNORM.COM : Click to view the full PDF of IEC 61000-5-6:2024

## INTERNATIONAL ELECTROTECHNICAL COMMISSION

**ELECTROMAGNETIC COMPATIBILITY (EMC) –****Part 5-6: Installation and mitigation guidelines –  
Mitigation of external EM influences**

## FOREWORD

- 1) The International Electrotechnical Commission (IEC) is a worldwide organization for standardization comprising all national electrotechnical committees (IEC National Committees). The object of IEC is to promote international co-operation on all questions concerning standardization in the electrical and electronic fields. To this end and in addition to other activities, IEC publishes International Standards, Technical Specifications, Technical Reports, Publicly Available Specifications (PAS) and Guides (hereafter referred to as "IEC Publication(s)"). Their preparation is entrusted to technical committees; any IEC National Committee interested in the subject dealt with may participate in this preparatory work. International, governmental and non-governmental organizations liaising with the IEC also participate in this preparation. IEC collaborates closely with the International Organization for Standardization (ISO) in accordance with conditions determined by agreement between the two organizations.
- 2) The formal decisions or agreements of IEC on technical matters express, as nearly as possible, an international consensus of opinion on the relevant subjects since each technical committee has representation from all interested IEC National Committees.
- 3) IEC Publications have the form of recommendations for international use and are accepted by IEC National Committees in that sense. While all reasonable efforts are made to ensure that the technical content of IEC Publications is accurate, IEC cannot be held responsible for the way in which they are used or for any misinterpretation by any end user.
- 4) In order to promote international uniformity, IEC National Committees undertake to apply IEC Publications transparently to the maximum extent possible in their national and regional publications. Any divergence between any IEC Publication and the corresponding national or regional publication shall be clearly indicated in the latter.
- 5) IEC itself does not provide any attestation of conformity. Independent certification bodies provide conformity assessment services and, in some areas, access to IEC marks of conformity. IEC is not responsible for any services carried out by independent certification bodies.
- 6) All users should ensure that they have the latest edition of this publication.
- 7) No liability shall attach to IEC or its directors, employees, servants or agents including individual experts and members of its technical committees and IEC National Committees for any personal injury, property damage or other damage of any nature whatsoever, whether direct or indirect, or for costs (including legal fees) and expenses arising out of the publication, use of, or reliance upon, this IEC Publication or any other IEC Publications.
- 8) Attention is drawn to the Normative references cited in this publication. Use of the referenced publications is indispensable for the correct application of this publication.
- 9) IEC draws attention to the possibility that the implementation of this document may involve the use of (a) patent(s). IEC takes no position concerning the evidence, validity or applicability of any claimed patent rights in respect thereof. As of the date of publication of this document, IEC had not received notice of (a) patent(s), which may be required to implement this document. However, implementers are cautioned that this may not represent the latest information, which may be obtained from the patent database available at <https://patents.iec.ch>. IEC shall not be held responsible for identifying any or all such patent rights.

IEC 61000-5-6 has been prepared by subcommittee 77C: High power transient phenomena, of IEC technical committee 77: Electromagnetic compatibility. It is an International Standard.

This first edition cancels and replaces the first edition of IEC TR 61000-5-6 published in 2002. This edition constitutes a technical revision.

This edition includes the following significant technical changes with respect to the previous edition:

- a) updating the whole document to include other HPEM environments including IEMI;
- b) adding a new Annex A which provides details on the concept of EM resilience and includes information on HPEM detectors, recovery and restoration.

The text of this International Standard is based on the following documents:

Draft	Report on voting
77C/339/FDIS	77C/340/RVD

Full information on the voting for its approval can be found in the report on voting indicated in the above table.

The language used for the development of this International Standard is English.

This document was drafted in accordance with ISO/IEC Directives, Part 2, and developed in accordance with ISO/IEC Directives, Part 1 and ISO/IEC Directives, IEC Supplement, available at [www.iec.ch/members\\_experts/refdocs](http://www.iec.ch/members_experts/refdocs). The main document types developed by IEC are described in greater detail at [www.iec.ch/publications](http://www.iec.ch/publications).

A list of all parts in the IEC 61000 series, published under the general title *Electromagnetic compatibility (EMC)*, can be found on the IEC website.

The committee has decided that the contents of this document will remain unchanged until the stability date indicated on the IEC website under [webstore.iec.ch](http://webstore.iec.ch) in the data related to the specific document. At this date, the document will be

- reconfirmed,
- withdrawn, or
- revised.

**IMPORTANT – The "colour inside" logo on the cover page of this document indicates that it contains colours which are considered to be useful for the correct understanding of its contents. Users should therefore print this document using a colour printer.**

## INTRODUCTION

IEC 61000 is published in separate parts according to the following structure:

### **Part 1: General**

General considerations (introduction, fundamental principles)

Definitions, terminology

### **Part 2: Environment**

Description of the environment

Classification of the environment

Compatibility levels

### **Part 3: Limits**

Emission limits

Immunity limits (in so far as they do not fall under the responsibility of the product committees)

### **Part 4: Testing and measurement techniques**

Measurement techniques

Testing techniques

### **Part 5: Installation and mitigation guidelines**

Installation guidelines

Mitigation methods and devices

### **Part 6: Generic standards**

### **Part 9: Miscellaneous**

Each part is further subdivided into several parts, published either as international standards or as technical specifications or technical reports, some of which have already been published as sections. Others will be published with the part number followed by a dash and a second number identifying the subdivision (example: IEC 61000-6-1).

# **ELECTROMAGNETIC COMPATIBILITY (EMC) –**

## **Part 5-6: Installation and mitigation guidelines –**

### **Mitigation of external EM influences**

## **1 Scope**

This part of IEC 61000 covers guidelines for the mitigation of external electromagnetic influences impinging upon a facility or installation, aimed at ensuring electromagnetic compatibility (EMC) among electrical and electronic apparatus or systems. These influences include lightning, RF transmitters, power-line and telecom transients, high-altitude electromagnetic pulse (HEMP) and other high-power electromagnetic transients such as those from intentional electromagnetic interference (IEMI).

This document is intended for use by installers, manufacturers and users of sensitive electrical or electronic installations or systems. It applies primarily to new installations but, where economically feasible, it can be applied to extensions or modifications to existing facilities.

While the technical principles are applicable to individual equipment or apparatus, such application is not included in the scope of this document.

## **2 Normative references**

The following documents are referred to in the text in such a way that some or all of their content constitutes requirements of this document. For dated references, only the edition cited applies. For undated references, the latest edition of the referenced document (including any amendments) applies.

IEC 60364 (all parts), *Low-voltage electrical installations*

IEC TR 61000-5-2, *Electromagnetic compatibility (EMC) – Part 5: Installation and mitigation guidelines – Section 2: Earthing and cabling*

IEC 61508-1, *Functional safety of electrical/electronic/programmable electronic safety-related systems – Part 1: General requirements*

IEC 62305 (all parts), *Protection against lightning*

IEEE Std 1848-2020, *Techniques and Measurement to Manage Functional Safety and Other Risks with Regards to Electromagnetic Disturbances*

## **3 Terms, definitions and abbreviated terms**

### **3.1 Terms and definitions**

For the purposes of this document, the following terms and definitions apply.

ISO and IEC maintain terminology databases for use in standardization at the following addresses:

- IEC Electropedia: available at <https://www.electropedia.org/>
- ISO Online browsing platform: available at <https://www.iso.org/obp>

### 3.1.1

#### **apparatus**

device or assembly of devices which can be used as an independent unit for specific functions

Note 1 to entry: In English, the term "apparatus" sometimes implies use by skilled persons for professional purposes.

[SOURCE: IEC 60050-151:2001, 151-11-22]

### 3.1.2

#### **attenuation**

ratio of the input to the output values of quantities of the same kind in a device or system

Note 1 to entry: When this ratio is less than unity it is usually replaced by its reciprocal, the gain.

[SOURCE: IEC 60050-312:2001, 312-06-06]

### 3.1.3

#### **device**

material element or assembly of such elements intended to perform a required function

Note 1 to entry: A device may form part of a larger device.

[SOURCE: IEC 60050-151:2001, 151-11-20]

### 3.1.4

#### **earthing**

#### **grounding, US**

electric connections between conductive parts and local earth

[SOURCE: IEC 60050-195:2021, 195-01-24]

### 3.1.5

#### **earth electrode**

#### **ground electrode, US**

conductive part that is in electric contact with local earth, directly or through an intermediate conductive medium

[SOURCE: IEC 60050-195:2021, 195-02-01]

### 3.1.6

#### **earthing arrangement**

#### **grounding arrangement, US**

all electrical means involved in the earthing of a system, installation or equipment

Note 1 to entry: Electric connection and devices used for earthing are examples of electrical means.

[SOURCE: IEC 60050-195:2021, 195-02-20]

### 3.1.7

#### **electromagnetic compatibility**

#### **EMC**

ability of equipment or a system to function satisfactorily in its electromagnetic environment without introducing intolerable electromagnetic disturbances to anything in that environment

[SOURCE: IEC 60050-161:2018, 161-01-07]

**3.1.8****electromagnetic disturbance**

electromagnetic phenomenon that can degrade the performance of a device, equipment or system, or adversely affect living or inert matter

Note 1 to entry: An electromagnetic disturbance can be an electromagnetic noise, an unwanted signal or a change in the propagation medium itself.

Note 2 to entry: In French, the terms "perturbation électromagnétique" and "brouillage électromagnétique" designate respectively the cause and the effect and should not be used indiscriminately.

Note 3 to entry: In English, the terms "electromagnetic disturbance" and "electromagnetic interference" designate respectively the cause and the effect and should not be used indiscriminately.

[SOURCE: IEC 60050-161:2018, 161-01-05]

**3.1.9****electromagnetic interference****EMI**

degradation in the performance of equipment or transmission channel or a system caused by an electromagnetic disturbance

Note 1 to entry: In French, the terms "perturbation électromagnétique" and "brouillage électromagnétique" designate respectively the cause and the effect and should not be used indiscriminately.

Note 2 to entry: In English, the terms "electromagnetic disturbance" and "electromagnetic interference" designate respectively the cause and the effect and should not be used indiscriminately.

[SOURCE: IEC 60050-161:2018, 161-01-06]

**3.1.10****electromagnetic screen****electromagnetic shield (US)**

screen of conductive material intended to reduce the penetration of a time-varying electromagnetic field into a given region

[SOURCE: IEC 60050-151:2001, 151-13-12]

**3.1.11****equipment**

single apparatus or set of devices or apparatuses, or the set of main devices of an installation, or all devices necessary to perform a specific task

Note 1 to entry: Examples of equipment are a power transformer, the equipment of a substation, measuring equipment.

[SOURCE: IEC 60050-151:2001, 151-11-25]

**3.1.12****equipotential bonding**

set of electric connections intended to achieve equipotentiality between conductive parts

[SOURCE: IEC 60050-195:2021, 195-01-10]

**3.1.13****facility**

entity (such as a hospital, a factory, machinery, etc.) that is built, constructed, installed or established to perform some particular function or to serve or facilitate some particular end

**3.1.14****filter**

linear two-port device designed to transmit spectral components of the input quantity according to a specified law, generally in order to pass the components in certain frequency bands and to attenuate those in other bands

[SOURCE: IEC 60050-151:2001, 151-13-55]

**3.1.15****high-altitude electromagnetic pulse****HEMP**

electromagnetic pulse produced by a nuclear explosion outside the earth's atmosphere

Note 1 to entry: This typically occurs above an altitude of 30 km.

**3.1.16****intentional electromagnetic environment****IEME**

totality of high-power transient radiated or conducted electromagnetic phenomena, which are generated intentionally to produce interference in electrical and electronic systems

Note 1 to entry: IEMEs can be generated for defence, law enforcement or for malicious purposes.

**3.1.17****intentional electromagnetic interference****IEMI**

effect of an intentional electromagnetic environment introducing noise or signals into electrical and electronic systems, thus disrupting, confusing or damaging these systems

**3.1.18****installation**

one apparatus or a set of devices and/or apparatuses associated in a given location to fulfil specified purposes, including all means for their satisfactory operation

[SOURCE: IEC 60050-151:2001, 151-11-26]

**3.1.19****local earth****local ground, US**

part of the earth that is in electric contact with an earth electrode and that has an electric potential not necessarily equal to zero

[SOURCE: IEC 60050-195:2011, 195-01-03]

**3.1.20****port of entry****PoE**

physical location (point) on an electromagnetic barrier, where EM energy can enter or exit a topological volume, unless an adequate PoE protective device is provided

Note 1 to entry: A PoE is not limited to a geometrical point.

Note 2 to entry: PoEs are classified as aperture PoEs or conductive PoEs according to the type of penetration. They are also classified as architectural, mechanical, structural or electrical PoEs according to the functions they serve.

**3.1.21****residual current**

peak current that appears at the output terminals of an SPD or filter during application of a standard stress at the input terminals

**3.1.22****residual voltage**

peak value of voltage that appears at the output terminals of an SPD or filter during application of a standard stress at the input terminals

**3.1.23****resilience****electromagnetic resilience**

features of a system that enable the system to be prepared for, to withstand, to respond to and to recover from a transient electromagnetic disturbance(s) in a timely and efficient manner

**3.1.24****screen****shield (US)**

device intended to reduce the penetration of an electric, magnetic or electromagnetic field into a given region

[SOURCE: IEC 60050-151:2001, 151-13-09]

**3.1.25****shielded enclosure****screened room**

mesh or sheet metallic housing designed expressly for the purpose of separating electromagnetically the internal and the external environment

[SOURCE: IEC 60050-161:1990, 161-04-37]

**3.1.26****shielding effectiveness**

for a given external source, ratio of electric or magnetic field strength at a point before and after the placement of the shield in question

**3.1.27****surge-protective device****SPD**

device that is intended to protect the electrical apparatus from transient overvoltages and to divert surge currents

Note 1 to entry: A surge-protective device contains at least one non-linear component.

[SOURCE: IEC 60050-614:2016, 614-03-48, modified – "SPD" has been added to the term.]

**3.1.28****system**

set of interrelated elements considered in a defined context as a whole and separated from their environment

Note 1 to entry: A system is generally defined with the view of achieving a given objective, e.g. by performing a definite function.

Note 2 to entry: Elements of a system can be natural or man-made material objects, as well as modes of thinking and the results thereof (e.g. forms of organization, mathematical methods, programming languages).

Note 3 to entry: The system is considered to be separated from the environment and the other external systems by an imaginary surface, which cuts the links between them and the system.

Note 4 to entry: The term "system" should be qualified when it is not clear from the context to what it refers, e.g. control system, colorimetric system, system of units, transmission system.

[SOURCE: IEC 60050-151:2001, 151-11-27]

### 3.1.29

#### **waveguide below cut-off**

evanescent waveguide (deprecated)

cut-off waveguide (deprecated)

waveguide used below the waveguide cut-off frequency

[SOURCE: IEC 60050-726:1982, 726-03-19]

## 3.2 Abbreviated terms

CCTV	closed circuit television
DM-DM	differential-mode-to-differential-mode
EMC	electromagnetic compatibility
EMI	electromagnetic interference
ESM	Electronic surveillance measures
HEMP	high-altitude electromagnetic pulse
HPEM	high-power electromagnetic
HVAC	heating ventilation and air conditioning
ICT	information communications technology
IEMI	intentional electromagnetic interference
PoE	port of entry
SPD	surge-protective device
UPS	uninterruptible power supply

## 4 Overview and general considerations

### 4.1 Overview

This part of IEC 61000 covers guidelines for the mitigation of external electromagnetic influences impinging upon a facility, aimed at ensuring electromagnetic compatibility (EMC) among electrical and electronic apparatus or systems. These influences include lightning, RF transmitters, power-line and telecom transients, high-altitude electromagnetic pulse (HEMP) and other high-power electromagnetic transients such as those from intentional electromagnetic interference (IEMI). More particularly, this document is concerned with a protection-led approach which includes concepts such as the arrangement of shielding and screening against radiated disturbances, and with mitigation of conducted disturbances. These arrangements include appropriate electromagnetic barriers for industrial, commercial, and residential installations. Mitigation shall be required if EMC between an apparatus and its intended operating environment is not achieved or is not likely to be achievable.

The concept of barriers installed for mitigating potentially penetrating and unwanted electromagnetic noise is applicable even when there is no designed-in electromagnetic shield. The enclosure through which power and signal (communications, control, etc.) cables can enter or exit, can be considered as a potential electromagnetic barrier that will provide some level of protection. The concept of enclosures can be understood as the perimeter walls of a building, the walls of a single room, or the housing of an apparatus, with protection installed at all points of electromagnetic penetration into the enclosure.

Where human functional safety risks (as defined in IEC 61508-1) have to be reduced to acceptable levels, it is probable that the EMI protections and mitigations described in this document will not be sufficient, and that the electromagnetic resilience approach described in IEEE Std 1848<sup>TM</sup>-2020 will also be necessary.

This document includes an informative annex (Annex A) describing the concept of a resilience-based approach for the mitigation of external high power electromagnetic environments.

## 4.2 General considerations

### 4.2.1 Elementary interference control

In its simplest form, the interference problem consists of a source of disturbance, a victim and the medium between the two. Interference control consists in suppressing the disturbance source, strengthening the victim, or impeding the source-victim interaction through the medium. When the source is not controllable (for example, lightning, portable transmitters, HEMP, etc.), and the inherent strength of the victim is dictated by other considerations (for example, circuit density and operating power), interference control is relegated to the intervening medium. Furthermore, for interference control oriented toward victim protection, control measures tend to be applied fairly close to the susceptible circuits (at the apparatus, system or subsystem levels).

Increasing the separation between them, enclosing one or the other in a shield or orientating them in the direction that reduces cross-coupling (for example, rejecting common-mode interference on differential-mode signalling lines) can reduce the interaction between source and victim. All three techniques can be combined to form a closed electromagnetic barrier between the source and the victim. For sources outside the system, the barrier can be applied at the system level. Where the system is considered to be the whole installation or facility, then the barrier can be a whole room or even the whole building. For sources inside the system, electromagnetic compatibility requires two barriers: one at the source to control emissions, and one at the victim to control susceptibility. This concept is illustrated in Figure 1. In this document, there will be a focus on sources outside the system.

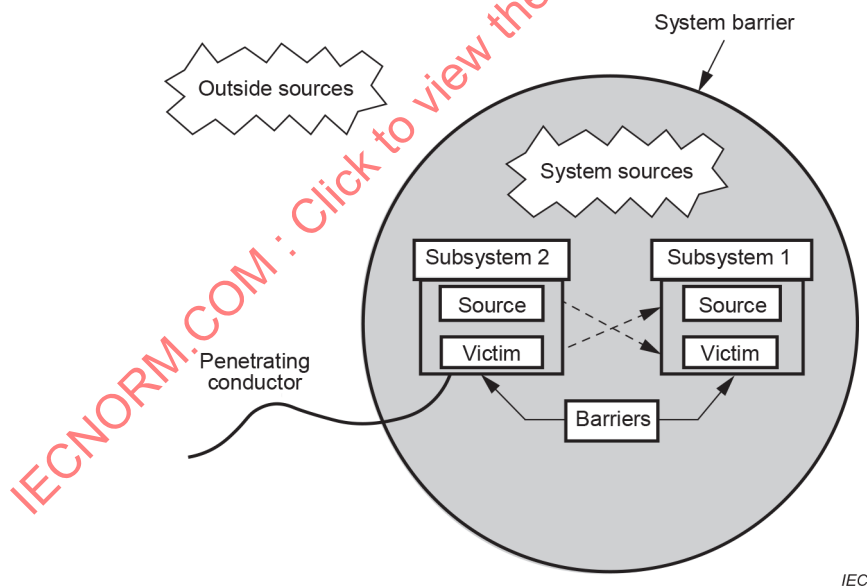


Figure 1 – System barrier topology

### 4.2.2 Shields and interfaces

Shields are used for attenuating the direct coupling of radiated electromagnetic disturbances from the external environment onto the internal electronics circuits and, conversely, to limit the radiation of disturbances from the internal circuits to the exterior, thus contributing to the electromagnetic compatibility (EMC) of the installation. The shields considered in this document are electromagnetically closed structures. Any form of electromagnetically open structure is not recommended for achieving a fully compliant installation. Some examples of structural shielding applications include:

- telecom facilities, such as relay stations, multipurpose radio installations;
- datacentres;
- electrical sub-station control rooms and control houses;
- TV and broadcasting studios;
- test rooms and laboratories (telecom, metrology, high-voltage engineering);
- metrology facilities in educational institutions;
- diagnostic and therapy rooms in medical facilities;
- computer rooms for business and industry.

Interface protection devices are used for mitigating the propagation of conducted electromagnetic disturbances from the external environment into the internal electronics and can, conversely, limit the emission of disturbances from the internal electronics into the external environment. This assumes that bi-directional protection devices are applied. Thus, when installed in conjunction with a shield, these devices contribute to achieving electromagnetic compatibility for the installation. Protection devices that will be discussed in this document include filters, decoupling devices and surge-protective devices (SPDs).

The filters considered in this document are limited to low-voltage passive circuits for high-frequency disturbances that are part of an installation. Filters and other interface devices incorporated in individual apparatus are not included within the scope of this document. Low-frequency filters, such as those used to mitigate power-line harmonics, are also not included in the scope of this document.

A complete installation can include the interconnection of several properly shielded cabinets with screened cables. However, the selection of such cables and proper bonding of the cable screens is not within the scope of this document but is addressed in IEC TR 61000-5-2.

The installation of filters and other mitigation means, including shields, is predicated on the existence of a properly designed earthing system, as described in IEC TR 61000-5-2.

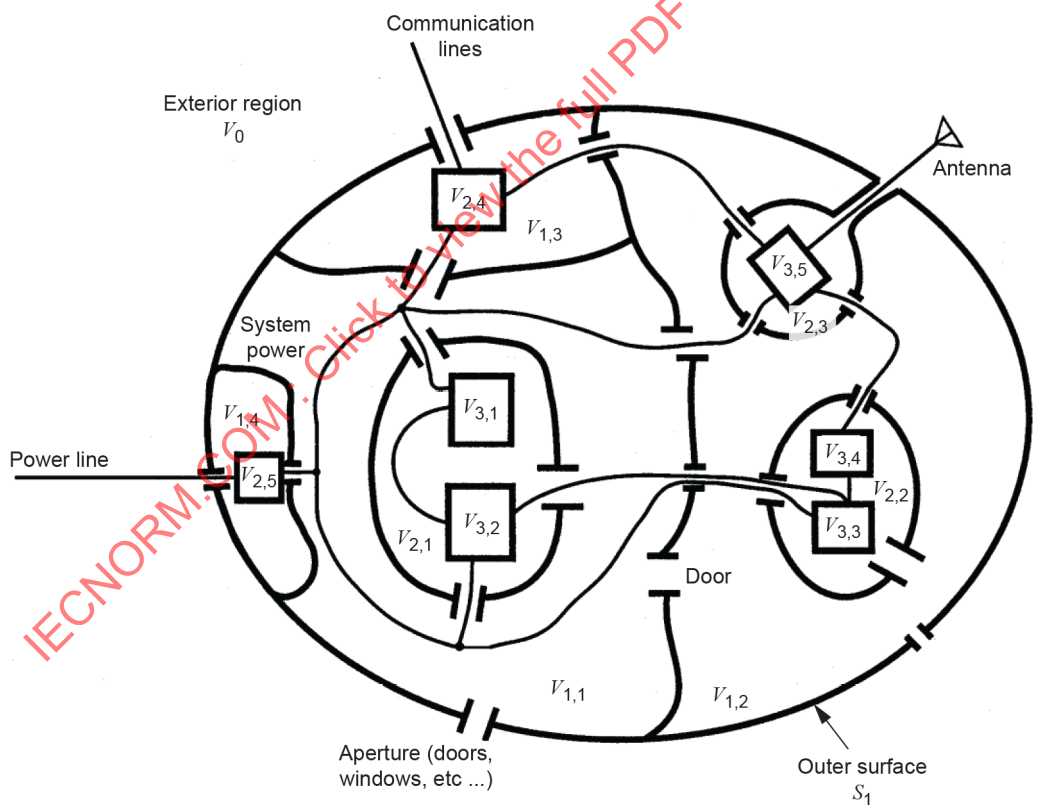
The recommendations and requirements presented in this document address the EMC concerns of the installation. The safety aspects of any installation are of prime importance but while not ignored, are not within the scope of this document. Reference to safety issues can be found in IEC 61508-1 and the IEC 60364 series. The efficient transportation of power within the installation is a prime function of any facility but is also excluded from the scope of this document. Nevertheless, these two issues are taken into consideration in the recommendations concerning EMC. These two issues can be implemented concurrently for enhanced EMC of the installed sensitive apparatus or systems without conflict by applying the recommended practices and requirements presented in this document and the relevant safety requirements such as those of IEC 61508-1 and the IEC 60364 series. As each installation is unique, it is the responsibility of the designer and the installer to select and abide by the relevant recommendations most appropriate to a particular installation. It is important to note that the recommendations and requirements presented in this document do not seek to preclude existing installation practices, when they have been shown to perform satisfactorily. Special mitigation methods might not be necessary when the installed equipment satisfies applicable emission and immunity standards.

## 5 Mitigation of radiated and conducted disturbances

### 5.1 Topological concepts

As a practical matter, the apparatus, sub-system or system inside the facility to be protected is required to communicate with the outside world via conductive and non-conductive (radiating) paths that penetrate the enclosure's electromagnetic shield and thus introduce imperfections (openings) in the shield. In addition, other penetrations can be introduced for entry and egress as well as for providing internally a controlled environment for system operators as well as for the internal equipment, such as electronics, water, air, sewers, etc. Therefore, a conceptually simple problem can become quite complex electromagnetically. The concept of topological control has been introduced to account for a system's inherent electromagnetic complexity. Such a concept can be applied to simplify both the system's electromagnetic coupling problem and to develop and implement electromagnetic interference control.

In Figure 2 a generalized, but simple, system topology enclosed in a volume surrounded by the outer surface is shown. The outer surface can be fabricated from common materials (concrete, brick, steel reinforcing bars, metal, etc.) and is penetrated by conductive and non-conductive penetrations such as doors, windows, seams, electrical lines, plumbing, etc. The electronic equipment can be located in different compartments or rooms. This equipment is usually interconnected by wiring harnesses or cables. Environmental control equipment and ducts can also interconnect the equipment rooms. These conductors provide paths for electromagnetic energy to either exit or enter the enclosure.



IEC

**Figure 2 – Generalized system topology**

All electrical devices, systems and installations produce or utilize at various frequencies energy which propagates through conductors connected to the apparatus. This energy can interfere with other equipment. Screening can be necessary either to protect a facility from an external electromagnetic environment, or to prevent the radiation of electromagnetic disturbances created by the internal equipment operation.

A formal topological approach can be used

- a) to describe the system, and
- b) to design a consistent approach to protect the equipment.

A formal approach for decomposing a system into its smaller, more tractable, parts is possible. Following the notation provided in Figure 2 the generalized system is subdivided into volumes and surfaces. The exterior region or volume is identified as  $V_0$ ; interior volumes or layers are identified as  $V_{j,k}$ , where the first subscript indicates the surface traversed (outside to inside) and the second subscript indicates the volume within that ( $j^{\text{th}}$ ) surface. The topological approach aids in identifying the various surfaces and volumes in a particular system and is very useful in describing and accounting for system electromagnetic shields. The notation can be used for further analysis. For example, in Figure 2, the surface of volume 2 can have different characteristics in the boundaries to volume 1 and volume 3. This approach also aids in accounting for the assessment of every penetration in all surfaces.

## 5.2 Mitigation needs

Mitigation is required if EMC between an apparatus and its intended operating environment is not achieved or is not likely to be achievable. However, if EMC has been achieved then no further mitigation is required. Mitigation can be achieved by using several different approaches described in this document as well as others, including through the use of a barrier between the source and the victim. For conducted disturbances this barrier is typically a combination of SPDs and filters or other decoupling devices, and for radiated disturbances it can be a screen and perhaps a filter as necessary, the attenuation of which is compatible with that of the screen in the frequency range considered.

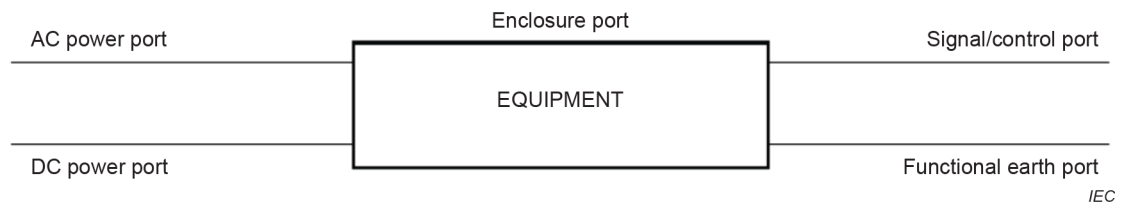
The attenuation provided by a barrier shall be compatible with the need, that is, be at least equal to the difference between the disturbance level and the immunity level of the apparatus to that disturbance. For verification purposes, in most of the cases, disturbances are simulated and the immunity of an apparatus is compared against a standard. Thus, the barrier performance required shall correspond to the difference between the disturbance level (expected or measured) and the immunity level determined in a laboratory test or by reference to an established immunity level.

According to uncertainties on disturbance level(s) and immunity level(s), a margin shall be considered as well, and added to the basic barrier performance required. This margin generally depends on the criticality of the equipment. For most low-risk domestic or industrial applications of equipment satisfying applicable EMC requirements, it is not necessary to have additional mitigation.

Where it is necessary to reduce human functional safety risks (as defined in IEC 61508-1) to acceptable levels, it is probable that the EMI protections and mitigations described in this document will not be sufficient, and that the electromagnetic resilience approach described in IEEE Std 1848-2020 will also be necessary.

## 5.3 The general concept of enclosure

As discussed in IEC TR 61000-5-1, it is useful to extend the concept of enclosure as being the boundary of a facility. An enclosure can be envisaged as a complete building, a room, a rack, a single cabinet and even, by extension of the concept, as an individual apparatus or a circuit board within an apparatus. This facility interfaces with its environment by "ports-of-entry" as shown in Figure 3. IEC TR 61000-5-1 provides further discussion of the concept of ports.



**Figure 3 – Ports of an apparatus or facility**

The scope of this document is restricted to the practices involved in the implementation of the electrical installation in a facility. These activities involve the selection of functional elements of the system and the relevant interconnections. This shall also include the interconnection to external sensors, actuators, telecommunication networks and the power supply.

#### 5.4 Interactions at the enclosure boundary

Interactions at the enclosure boundary involve two directions of propagation:

- disturbances originating in the external environment that can enter the enclosure;
- disturbances generated within the enclosure that can exit the enclosure;

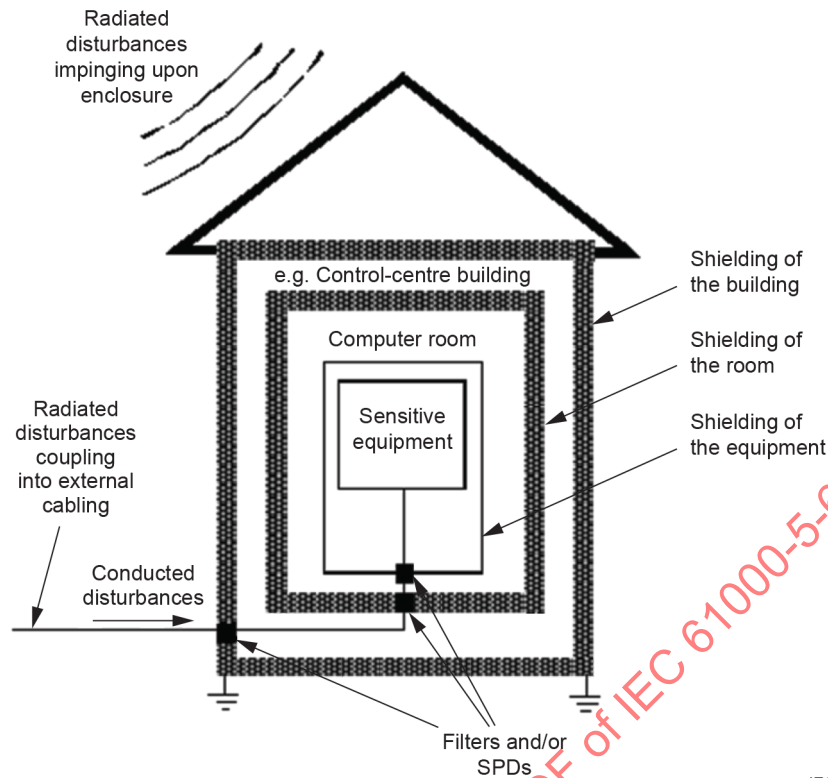
This document presents the fundamental concepts for installation practices that limit radiated disturbances by shielding and screening and limiting the propagation of conducted disturbances across the enclosure boundaries through the use of filters, decoupling devices, and overvoltage protective devices.

## 6 Shielding

### 6.1 General

Electromagnetic shielding of buildings, rooms, compartments, cabinets, rack chassis and equipment makes it possible to ensure compliance with the EMC for equipment exposed to radiated disturbances. A topological concept is shown in Figure 4.

IEC TR 61000-2-5 can be used as a guide for EMC limits within each zone, and IEC 61000-2-11 and IEC TR 61000-5-3 together can be used as a guide to develop HEMP limits within each zone. Low-frequency electric fields are relatively easy to mitigate. Low-frequency magnetic fields are more difficult to screen and will involve a shield with a large wall thickness or a high permeability, or both. IEC 61000-5-7 can be used to qualify the protection levels for equipment enclosures once the level of desired protection is identified.



**Figure 4 – Topological concept of shields with interfaces at penetration points**

Screening of rooms and cabinets with appropriate penetration protection is only one of several actions that can be used to limit the effect of radiated electromagnetic disturbances. For instance, maintaining appropriate distances between emitters and victims is a relatively effective means of mitigation for radiated disturbances. Obtaining a satisfactory result can involve other actions such as:

- a) selecting correct cabling and wiring (adding a screen jacket over cables or wires, selecting and correctly terminating shielded cable);
- b) applying good cable layout and cable management;
- c) implementing good earthing and bonding practices;
- d) using devices limiting transient disturbances or increasing equipment immunity.

IEC TR 61000-5-1 and IEC TR 61000-5-2 can be referred to for additional guidelines concerning these actions.

The objective of Clause 6 is to present the main arrangements used in mitigation methods involving shielding of installations, such as:

- introduction of the concept of mitigation zones and review of the corresponding types of shielded enclosures;
- guidance on preservation of shielding effectiveness for housings with apertures based on a set of generic EMC rules;
- generic information on the implementation of screening, progressing from the sensitive apparatus to the complete building, as well as on the means of dealing with the unavoidable apertures or penetrations.

## 6.2 Classification of protection zones

### 6.2.1 General

For the purpose of designing and applying appropriate mitigation measures, it is useful to consider a hierarchy of zones of protection, from the unprotected environment to the strong protection of especially sensitive equipment. For the purposes of this document, the particular zones are defined as follows:

- zone 0 – no protection
- zone 1 – buildings protected by reinforced concrete outdoor walls
- zone 2 – rooms shielded by special materials
- zone 3 – internal equipment shielded by metallic materials or metallized enclosures
- zone 4 – sensitive apparatus enclosed within a special shielded rack

Figure 5 shows a schematic representation of the hierarchy of the classification for protection of zones 0 through 4. Note that it is possible that not all barriers are present in a given installation. Zones can be selected in a more arbitrary manner.

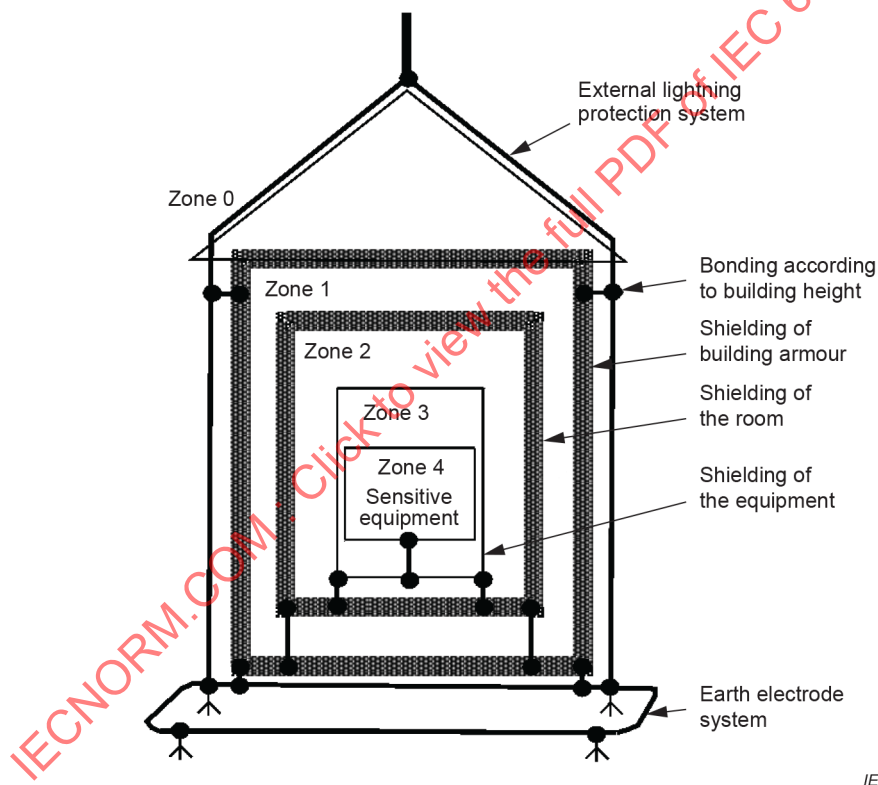


Figure 5 – Zones of protection of shielding and earthing systems

### 6.2.2 Zone 1 – Building shield

Zone 1 applies to buildings containing welded iron reinforcing bars for concrete outdoor walls. The reinforcement bars should be interconnected preferentially by as many welds as feasible. Thus, the reinforcement forms a good earthing structure. Note that it is possible that steel reinforcing bars are not always interconnected so that a good electrical bond is made. In such situations it is possible that the steel reinforcing bars do not represent an adequate shield. An important first measure is a well-designed and implemented lightning conductor with conductive connections to the earth. Unshielded or non-screened cables and other conductive penetrations shall be protected with appropriate mitigations such as limiting (surge-protective device) and filtering. Shielded or screened cables entering this zone shall have a 360° circumferential, galvanically bonded connection to a metal plate, which in turn is galvanically bonded to the conductors in the walls.

### 6.2.3 Zone 2 – Room shield

Zone 2 applies to indoor facilities with protection measures. In this case the shield is effective when it consists of continuously connected (welded) sheet-metal walls or walls with a metal surface. Bolted or otherwise interconnected walls will result in some degradation of the shielding effectiveness. All the screens of cables entering this zone shall have a 360° circumferential, galvanically bonded connection to the metal walls. The penetrating cables shall also be protected against overvoltages with appropriate mitigations such as limiting (surge-protective device) and filtering.

### 6.2.4 Zone 3 – Equipment shield

Zone 3 applies where individual apparatus is protected by metal cabinets or metallized enclosures. The earth connection shall be a low impedance connection to the earthing arrangement. Conductive penetrations shall be protected with appropriate mitigations such as limiting (surge-protective device) and filtering.

### 6.2.5 Zone 4 – Apparatus shield

Zone 4 applies at the individual apparatus level; it is not within the scope of this document, but is the responsibility of the apparatus manufacturer. This zone can also include highly sensitive equipment that can require additional protection.

## 6.3 Design principles for screening

### 6.3.1 General

The design principles presented in 6.3 are not intended to serve as comprehensive guidelines for the detailed design of a specific installation; rather, they are offered as an overview of design considerations that can serve as useful checks for a proposed installation. Providing effective screening techniques requires a design by specialists, taking into consideration the specifics of the installation. By application of different materials, it is possible to obtain a good shielding effectiveness over the whole disturbance spectrum of electromagnetic fields. Screening can be provided by the following materials and constructions:

- metallic enclosure or cabinets;
- rooms with continuous metallic walls;
- clamped or welded iron mats, grids and sheets inside of walls;
- metallic meshed wire or meshed screen;
- metallic or metallized fabric;
- metallic foil;
- metal sheets (copper or aluminium or other good conductive metals);
- metallized plastics with undamaged surfaces and a good contact across all seams;

- window glass with wire mesh fused in the glass or metallized glass, both continuously bonded to the wall shield.

Note that for screening against low-frequency electric fields, metallized plastic might be adequate. However, screening against low-frequency magnetic fields requires metal walls of sufficient thickness, conductivity and permeability. The electrical continuity of the walls shall be ensured, especially in the case of the lower frequency magnetic fields.

### 6.3.2 Shielding effectiveness

The effectiveness of a shielded enclosure depends on many parameters. In theory, a shielded enclosure can be designed to produce attenuation ranging from a few dB to over 100 dB in a frequency range up to 10 GHz and beyond. However, in practice, the effectiveness of an enclosure with penetrations of all types will be reduced and limited by these penetrations. For practical purposes, the shielding effectiveness of a solid metallic cabinet or enclosure is mainly determined by the following factors:

- the disturbance currents, which will flow over the outer surface of the cabinets or in closed loops over the surfaces via connections to the earth or ground;
- the installation of penetrating cables: for good performance all signal cables penetrating the cabinet shall either be filtered or limited and their screens shall be bonded directly to the cabinet (see IEC TR 61000-5-2);
- the electrical length of seams of all parts of the enclosure shall be as small as possible, preferably smaller than one-tenth of the wavelength of the impinging disturbance (this conditional limit is not applicable to low-frequency magnetic fields);
- the size of holes shall be as small as possible relative to the incident wavelength or shall be fitted with pipes (waveguide below cut-off); this topic is discussed further in 6.4.7.

### 6.3.3 Maintaining shielding effectiveness

The following is a set of simple rules that can help when checking whether a shielded enclosure is correctly installed.

- a) Ensure a correct path for all common-mode currents that can flow in cables entering the enclosure.

This rule implies that screens of all cables shall be connected over 360° to the wall of the shielded enclosure. It applies to all types of cables such as coaxial cables, screened multi-lead signal cables, power cables, etc. Screens can continue through the wall into the inside of the enclosure, as is for instance necessary for the correct signal transport by coaxial cables.

If the 360° circumferential contact cannot be maintained for some reason, the shortest possible connection between the cable screen and the wall, on the outside – not inside – of the enclosure, is recommended. This type of connection, however, will impair the quality of the shielded enclosure, particularly at higher frequencies.

- b) Ensure a correct path for all disturbance currents that can flow through any metallic object towards the shielded enclosure.

This rule applies for instance to metallic tubing for water or cooling liquid for air conditioners. Again, a 360° circumferential contact between the tubing and the wall is necessary.

- c) If possible, all conductors mentioned under rules a) and b) above shall enter through a single metal panel, far from large openings in the enclosure.

The metal wall of a shielded enclosure provides a short path for all common-mode currents and diverts those currents around the shielded enclosure; it thereby acts as a barrier for disturbances. Openings should normally be closed, such as doors equipped with contact strips. In some cases a double shield door can be warranted. Rule c) will still provide some protection if the doors are occasionally open. The EMC cabinet discussed in IEC TR 61000-5-2 is an example of this topology

- d) Limit the bandwidth of the signals or power entering the shielded enclosure to the bare minimum necessary for the particular signal. Employ filters and mount them correctly against the wall.

In particular, the way filters are mounted has the largest influence on their correct operation. A simple filter which is correctly mounted is preferable to an expensive filter which is incorrectly installed.

In addition, in large shielded rooms the power-input cable requires attention. A three-phase power cable, equipped with a neutral conductor and a protective earth inside an earthed screen is correctly installed if the earthed screen is circumferentially connected to the metal wall, as stipulated by rule a). The protective earth and the neutral conductors can also be connected there to the metal wall. Note that in some countries, national codes prohibit multiple connections of the neutral to the earthing system. In that case, a filter is also required for the neutral conductor.

- e) If any overvoltage protection is applied at a cable to limit the differential-mode voltage, the filters mentioned in rule d) above should be mounted between the SPDs and the shielded enclosure.

Note that SPDs of the voltage-switching type (see 9.5.3) can generate new fast disturbances when they operate. The filters, mounted downstream from the SPDs, shall reduce these SPD-related disturbances before they enter the shielded enclosure. Furthermore, the SPDs will serve to limit the external overvoltages impinging on the filters, allowing a more cost-effective selection of filters.

- f) Ensure that all walls of the shielded enclosure form a single metallic, well-conducting surface.

Different parts of the shielded enclosure should be interconnected over their full perimeter, preferentially by welding the seams. Other good ways of ensuring conducting seams, such as many bolts or screws, are allowed as well, but at a reduced shielding effectiveness. Painted surfaces divert the currents that provide the screening effect where these currents would cross the seams. Conductivity shall be maintained by removing the paint and applying corrosion protection. Alternate fastener methods can also be used, such as self-tapping screws, "pop-nails", etc.

- g) All openings in the wall of a shielded enclosure shall be carefully considered.

The following types of openings (apertures) can be encountered:

- a long slit, such as an open seam;
- a large circular hole;
- many small holes with the same open area as the large hole;
- holes protected by a mesh;
- holes protected by tubes or honeycomb arrays of tubes.

See 6.4.7 for further details on how to deal with these various types of apertures.

The specific implementation of a protection scheme will require a risk assessment of the overall protection so that the installation's benefit/cost can be determined.

## **6.4 Implementation of screening**

### **6.4.1 General**

In preceding subclauses (6.1 to 6.3), the necessity for screening has been described from the point of view of external influences impinging upon the facility, with a sequence of zones starting from the outside and progressing toward the equipment – the most significant part of the installation. When a facility is being designed for general EMC purposes, it is reasonable to begin the protection design from the outside and progress inward, taking advantage of an overall protection scheme, as described in IEC TR 61000-5-1. For HEMP environments the situation is the same, and IEC TS 61000-5-4 provides information on how to specify the screening levels once they are determined. When sensitive equipment is being installed in an existing building, it is more likely that any screening that would turn out to be necessary would start at the apparatus level and progress outward. Adding screening to an existing building is expensive, and its implementation will depend on the value of the equipment to be protected.

### **6.4.2 Sensitive apparatus**

Apparatus containing sensitive components can be shielded, if necessary, by metallic cage(s) or by metallized plastic box(es), depending on the needs. According to the definition of apparatus, that is, "placed on the market as a single commercial unit", the apparatus screening should be the responsibility of the apparatus manufacturer rather than the responsibility of the installer. However, if a mass-produced consumer-type apparatus designed for moderate environments is going to be installed in a harsh environment, the necessary adaptation becomes a concern for the installer.

### **6.4.3 Shielding of racks and chassis (zones 4/3 barrier)**

Metallic racks and chassis are furnished by various suppliers which control the shielding design. Typical shielding practices involve the assembly of many individual electrical and electronic building blocks that result in a single housing. In this case a metallic enclosure increases the shielding effectiveness.

### **6.4.4 Shielding of cabinets (zones 3/2 barrier)**

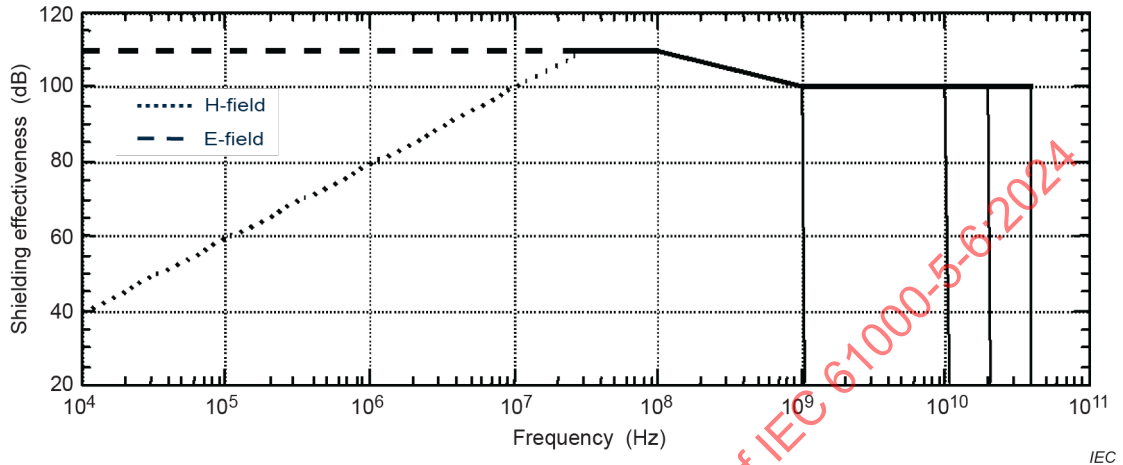
The use of shielded cabinets is necessary in the case of high electromagnetic fields, such as those greater than 30 V/m. These cabinets also provide protection against outgoing radiated disturbances.

Protection of cable penetrations can be obtained by use of special filters that are installed on the incoming cables (power and control/signal ports). These filters shall have a good bonding connection to the cabinet wall. All metal parts shall be bonded together with high quality, permanent connections via the shortest path to the earth/ground system. Most important is the treatment of the frame and the racks.

### **6.4.5 Shielding of rooms (zones 2/1 barrier)**

Good-quality shielded rooms, or shielded enclosures, have been in use for many years for performing electronic measurements where a low electromagnetic ambient level is necessary, or where potentially damaging emission has to be contained. Refer to IEC TR 61000-2-5 for acceptable ambient levels. The use of shielded rooms has been extended to non-measurement applications, such as protection of personnel working near high-power radar sites or industrial RF emission sources, and protection of sensitive equipment such as medical devices, biomedical instruments and computers.

The room shield can consist of meshed conductors inside of the walls such as steel reinforcing bars, grids or metal sheets installed on the surface of walls. Figure 6 represents the shielding effectiveness of a continuous solid metallic shield with penetration protection. Shielding provided by discontinuous conductors, such as steel reinforcing bars, will be much less than shown in Figure 6 (see Table 1). All doors and other openings (ventilation openings, windows, etc.) shall be constructed with screening material, and they shall have a short bonding strap to the other screening materials.



**Figure 6 – Example of performance of high-efficiency shielded enclosure**

**Table 1 – Measured shielding effectiveness of a 2 m × 2 m cage made of concrete building armour, against a 20 ns rise-time pulse (equivalent frequency less than 20 MHz)**

Type of armour			Attenuation	
			dB	
Diameter	Spacing	Bonding of bars	Electric field	Magnetic field
mm	mm			
14	200	Binding	6	4
14	100	Binding	No data	10
8	100	Binding	9	9
8	100	Welding	19	11

**6.4.6 Shielding of buildings (zones 1/0 barrier)**

The reinforcement bars of a concrete building can provide a limited screening effect up to 20 dB when implemented with a view toward EMC benefits, as illustrated by the experimental measurement results of Table 1. When a building consists of steel panels on a steel frame, appropriate EMC measures (bonding) applied at the time of construction can produce cost-effective benefits.

The shielding effectiveness of the armour can be improved by welding the connections of the reinforcement bars and adding armour grids of small diameter and mesh. The metal frames of all openings should be bonded to the armour at multiple points.

All incoming and outgoing leads (power network or data network) shall be protected against direct as well as indirect lightning discharges (see the IEC 62305 series). These lines can have an outer metallic sheathing that shall be bonded to the earthing system. If an outer sheathing is not present, protection by means of a filter or an SPD, or both, can be necessary. Both the filter and the SPD shall be connected to the nearest earthing arrangement at the point where the cables enter the building. If this is not practical, another suitable port of entry should be selected. For instance, with an antenna on the roof, the screen of the antenna cable should be connected to the local earthing arrangement of the roof. Often the screen of the cable connector can be used for this connection, providing a circumferential connection to a metallic wall. This measure is a very economical protection and far superior to a pigtail connection (a wire connecting the connector to the metallic wall).

## 6.4.7 Dealing with apertures

### 6.4.7.1 General

Apertures in a shield are generally unavoidable (cable entries, ventilation, windows). These openings can be designed as waveguides beyond cut-off. If they are constructed correctly, they can maintain the shielding effectiveness for a broad range of frequencies. Deliberate or unintended apertures and the uncontrolled entrance of cable jackets into enclosures create most of the weak points. Shield doors shall have metal surfaces and contact fingers over the full circumference. Ventilation openings shall be protected as indicated below. The effect of a window can be reduced by installing wire meshes, with dimensions depending on the frequency of the disturbing radiation. Window protection is available for indoor installation, and thermally insulated outer wall windows with metallic meshes sandwiched between glass plates can also be used. The achievable screening value depends on the number of mesh layers. The window mesh should be peripherally bonded to the facility shield.

### 6.4.7.2 Honeycombs

In a honeycomb array, the tube diameter and length should be selected for the maximum frequency at which the shielded enclosure can operate (Figure 7 and Figure 8) and shall be selected so that the array tubes operate as waveguides below cut-off at the high frequency of interest. All tubes shall form well-conducting contacts over the lines where they touch each other. Mesh or honeycomb arrays shall contact the wall in which they are mounted over their full perimeter.

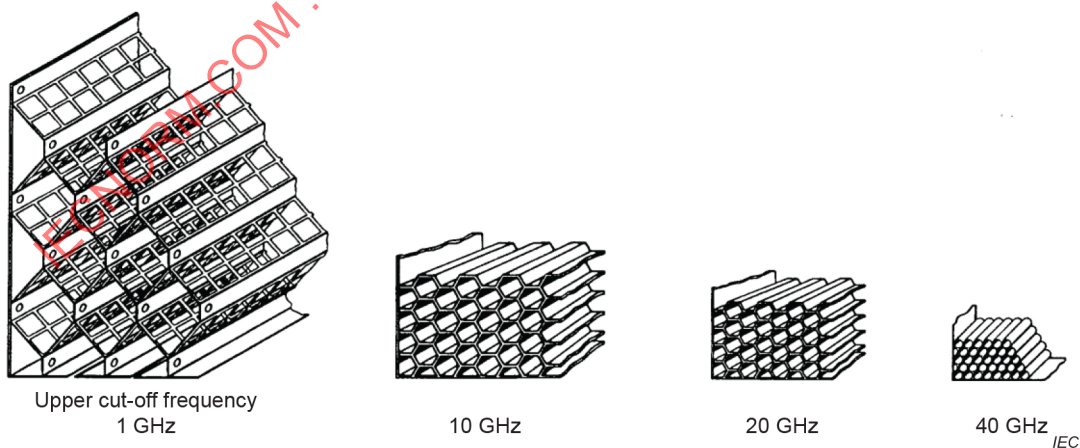
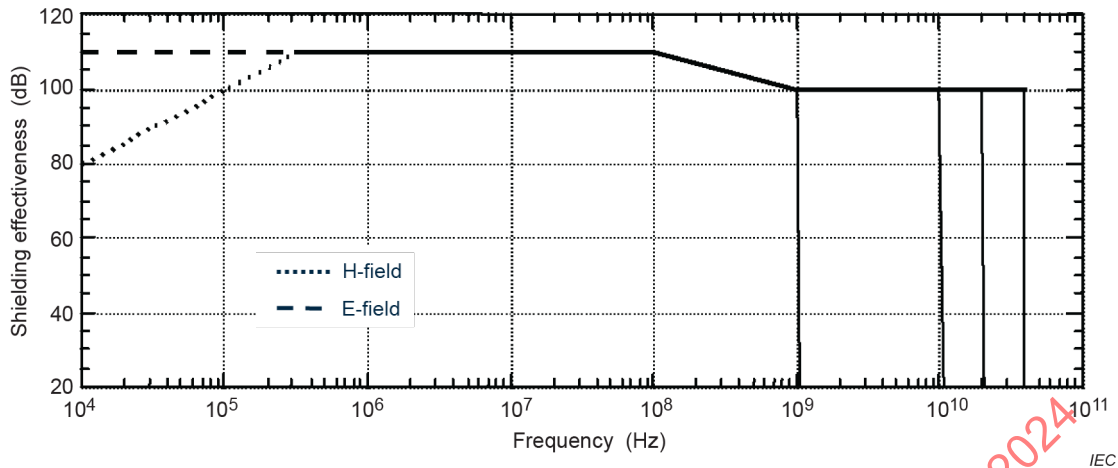


Figure 7 – Honeycomb inserts for different cut-off frequencies



**Figure 8 – Typical screening attenuation of honeycomb inserts**

Non-conductive tubing, such as water drains, shall be fitted inside a metal pipe. The dimensions of the pipes shall be chosen in a similar way to those of the honeycomb. The pipe should contact the wall over its full perimeter. Fibre optic cables shall penetrate a wall through a metallic pipe. No metal cladding or metal leads shall pass through the wall with the fibre cable without proper care for the disturbance currents.

#### 6.4.7.3 Conductive gaskets

Conductive gaskets are applied to reduce the effect of apertures and to maintain bonding of components of an enclosure. Such gaskets are employed for either temporary or semi-permanent sealing applications between joints or structures. The gasket is compressed between the mating surfaces to be bonded, thus providing the conductive path across the joint between them; screen currents can then flow without abrupt changes in current density across the joint, thus maintaining the ideal screen performance. Gaskets can be used to make firm, continuous and uniform contact with seam surfaces, to avoid joining only at irregular spots between the surfaces. There are three types of gaskets classified by usage:

- a) permanently mounted cover plates or assemblies: gaskets for these applications include knitted wire mesh gaskets pressed into the desired gasket shape, or soft metals such as indium;
- b) access cover plates with high joint unevenness, frequently opened but always closed on the same portions of the gaskets: elastomeric gaskets are used for this application;
- c) removable cover plates with symmetrical mounting patterns which are replaceable but not necessarily in the original orientation: the preferred gaskets are sponge elastomers with oriented wires which exhibit low closure force and low compression set and are removable and reusable.

#### 6.4.7.4 Gasket types and other materials

There are many types, shapes, binders, and materials for gaskets that are designed for EMC applications, as illustrated as follows. Their effectiveness is dependent upon the conductivity of the surfaces that require maintenance.

- a) Knitted wire mesh gaskets: These are made from resilient, conductive knitted wire and they somewhat resemble the outer jacket of a coaxial cable.
- b) Oriented-immersed wire gaskets: These are made with many fine parallel, transverse conductive wires providing very low parallel impedance across the gasket interface.
- c) Conductive plastics and elastomer gaskets: These are made with many tiny silver balls immersed in a silicone rubber or vinyl elastomer binder and a carrier.

- d) Spring-finger stock: Spring-finger contact strips now use conducting self-adhesive backing to eliminate older mechanical fastening methods. Manufacturers usually apply those strips because they facilitate a large area connection of doors to the shielded enclosure.

#### 6.4.7.5 Gasket mounting

Several methods are available to mount the gasket onto a metal mating surface such as:

- hold-in slot;
- pressure-sensitive adhesive;
- bond non-functional portion of gasket;
- conductive adhesive;
- bolt-through boltholes.

#### 6.4.7.6 EMC sealants

Many types of sealants are available, such as epoxies, caulking as rubber and elastics, and grease.

- a) Conductive epoxies: Conductive epoxies are used to join, bond, and seal two or more metallic mating surfaces.
- b) Conductive caulking: Conductive caulking is used to screen and seal two or more metallic mating members mechanically held by other means.
- c) Conductive grease: Conductive grease is a low-resistance, silver-silicone grease which contains no carbon or graphite fillers. Its principal use is for power substation switches and on suspension insulators to reduce EM disturbances.

## 7 Filters

### 7.1 General

Filters are used in power systems and in telecommunication and control system signal cables when disturbance levels do not correspond to the immunity level of the installed equipment. The general function of a filter is to limit the bandwidth; this function can be aimed at several goals, in order of decreasing importance:

- protect electronic equipment against unwanted disturbances, outside the frequency band of the intended signals;
- separate common-mode disturbances from differential-mode signals;
- limit differential-mode bandwidth to the minimum necessary operational width.

Filters can have a twofold effect by protecting the environment from conducted disturbances generated within equipment and by protecting the equipment against disturbances generated externally to the equipment concerned. This dual role assumes that the filter and other associated mitigating devices such as SPDs are bi-directional. A common application in installations is the limiting of high-frequency disturbances through the application of low-pass filters for power lines or voice-band telephone lines.

Two kinds of filters exist: passive filters and active filters. Active filters are generally incorporated into an apparatus for the purpose of signal processing rather than protection. This type of filter is not usually bi-directional. Active filters are excluded from the scope of this document. Passive filters, shunt or series, are designed with a combination of passive circuit components (resistors, inductors and capacitors). These filters pass signals within the passband and attenuate signals at other frequencies. Filters aimed at the mitigation of low-frequency disturbances are not included in the scope of this document.

When the designer of an installation considers the application of filters for the purpose of preventing interference from external sources, three questions should be resolved, depending on the function of the filter:

- a) Reflections: is the filter designed to properly match the source and load impedances?
- b) Insertion loss: does the filter introduce excessive losses or distortion to the normal operating signal?
- c) Non-linear performance: are the expected disturbance levels within the operating limits of the filter? Will new disturbances be generated if limits are exceeded?

**7.2 Fundamental filter characteristics**

**7.2.1 General**

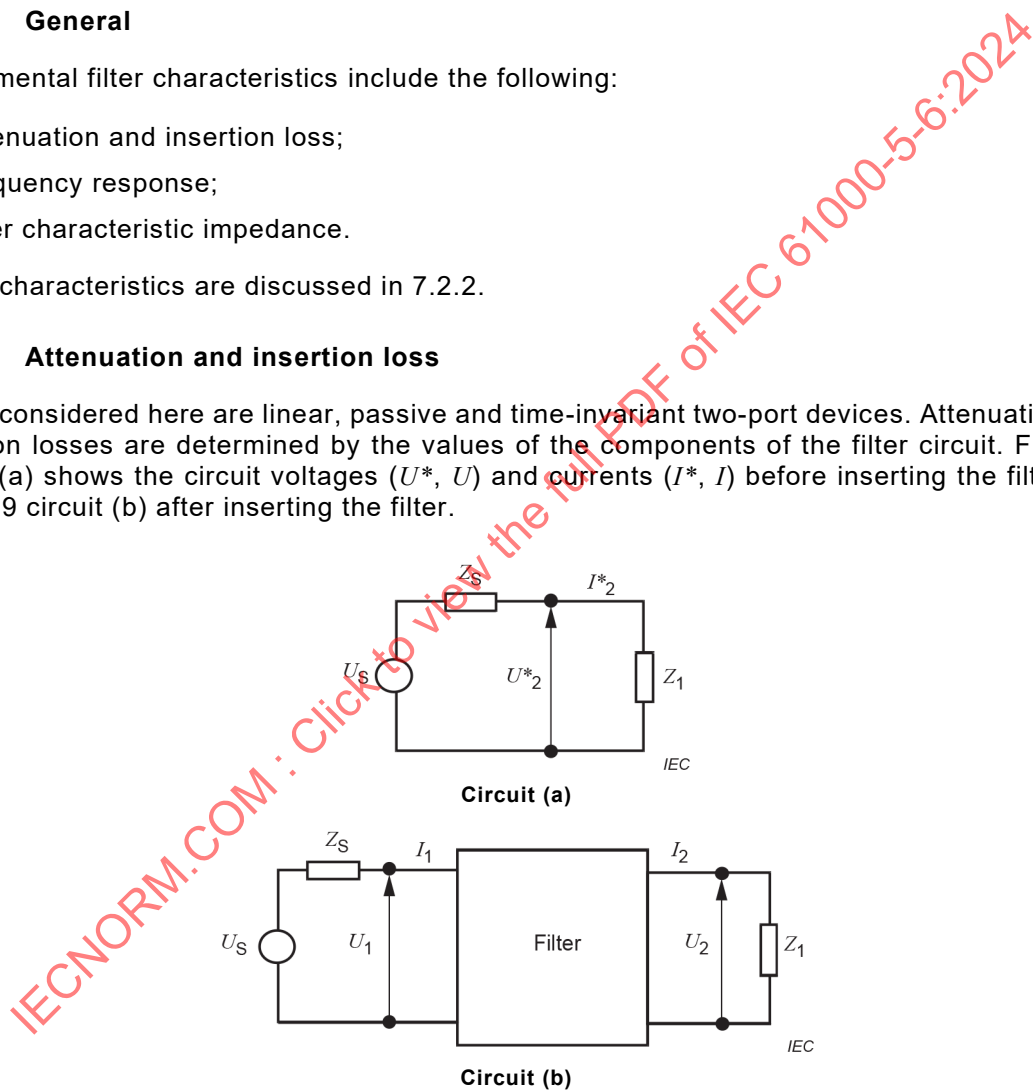
Fundamental filter characteristics include the following:

- attenuation and insertion loss;
- frequency response;
- filter characteristic impedance.

These characteristics are discussed in 7.2.2.

**7.2.2 Attenuation and insertion loss**

Filters considered here are linear, passive and time-invariant two-port devices. Attenuation and insertion losses are determined by the values of the components of the filter circuit. Figure 9 circuit (a) shows the circuit voltages ( $U^*$ ,  $U$ ) and currents ( $I^*$ ,  $I$ ) before inserting the filter and Figure 9 circuit (b) after inserting the filter.



**Figure 9 – Parameters for attenuation and insertion loss**

Attenuation and insertion loss are dependent on both the source impedance  $Z_s$  and the load impedance  $Z_l$ . The insertion loss ( $I$ ) refers to a specified test condition as shown in Figure 9 and is defined as the ratio of the load voltage before and after the insertion of the filter:

$$I = U_2^*/U_2 \text{ or } I = 20\log(U_2^*/U_2) \tag{1}$$

where

$I$  is the insertion loss expressed as a ratio or in dB;

$U$  is the voltage expressed in V.

CISPR 17 recommends the choice of  $Z_s$  and  $Z_l = 50 \Omega$ .

The attenuation can refer to different quantities, such as voltage attenuation  $U_s/U_2$ , absorption attenuation or total attenuation, depending on the characteristics of the source and load impedances.

It is common to characterize a filter with either its insertion loss or its total attenuation. Quite often, filters are chosen according to their insertion loss in a  $50 \Omega$  system where  $Z_l = Z_s = 50 \Omega$ . In this special case, the insertion loss is equal to the total attenuation. However, insertion loss and total attenuation are dependent on both the source impedance  $Z_s$  and the load impedance  $Z_l$ .

Note that it is not valid to compare or select filters for their  $50 \Omega$  system insertion loss if they are not being used with those load and source impedances. This is especially true when either the source or the load is reactive.

It is important to be aware that the (assumed linear) impedance of the signal source, of the filter and of the receiver protected by the filter are recommended to be known over a large frequency range, adapted to all possible disturbances, rather than to the frequency band for the signals only.

The impedance of a low-voltage power-line network assumes a large range of values, especially in the frequency range of 9 kHz to several tens of MHz. These impedances also change with time. Insertion loss or attenuation as defined above is therefore of little help in characterizing a power-line filter. In fact, a conservative design should only retain the worst possible behaviour of a power-line filter, when the network impedance assumes any random value. Such a value is called a worst-case value.

Interference suppression filters reach their highest in-band attenuation when they are mismatched with the impedance of the disturbance source, victim apparatus or the line. The simplest "low-pass filter" is a shunt-connected capacitor. In the case of a low-impedance source, the simplest low-pass filter is a series-connected suppression inductance.

### 7.2.3 Basic types of filters

Depending on the application, filters can be designed with RL, RC and RLC circuits in various combinations. Basic types of filters are briefly described below. In the most elementary form, filtering can be obtained by a series-connected inductance (as a ferrite bead or core threaded on a cable – saturation effects shall be taken into account) or a shunt-connected capacitor. Selection of a specific filter type will depend on the application, cost and required performance.

Passive filters utilize the resonance characteristics of series and parallel combinations of inductance and capacitance. The resulting reactance reduces disturbances by introducing a high impedance in series with the disturbance currents or by shunting these currents to earth through a low impedance, or both. Several types of filters can be identified.

- Low pass filter: allows the passage of low frequencies; attenuates high frequencies.
- High pass filter: allows the passage of high frequencies; attenuates low frequencies.
- Bandpass filter: passes a specific range of pass-band frequencies; attenuates signals with frequencies outside the passband.
- Stop-band filter: attenuates a specific range of frequencies within the stop-band; passes frequencies outside the stop-band.

All information concerning two-port filters can be adapted for multiport filters. In addition to the elementary filter types above, double-tuned filters are often used. These filters have one frequency at which parallel resonance occurs and another at which series resonance occurs. The former resonant frequency determines the rejected frequency, the latter the accepted frequency. The low-pass filter is the type most frequently used in EMC applications.

### 7.3 Functional tasks

Functional tasks of filters include:

- preventing interference on an installed apparatus by limiting incoming disturbances in power, control and communication circuits (Figure 10);
- reducing the outgoing electromagnetic noise in power networks and in the environment by limiting conducted disturbance emission of cables or radiation from the apparatus (Figure 11);
- preventing electromagnetic interference between pieces of equipment or within the equipment itself;
- providing a preferred path for the common-mode current (not only at frequencies inside the band-pass of the filter).

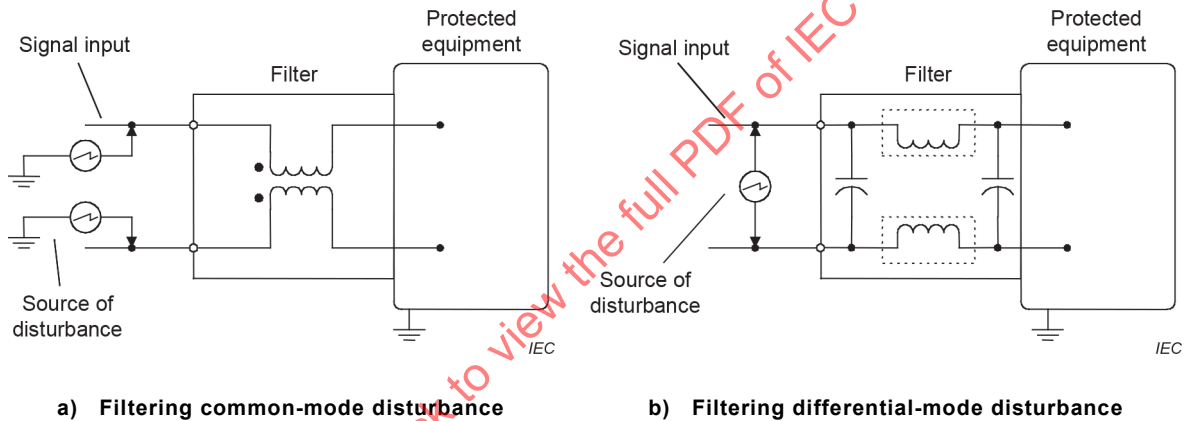


Figure 10 – Prevention of interference on installed equipment

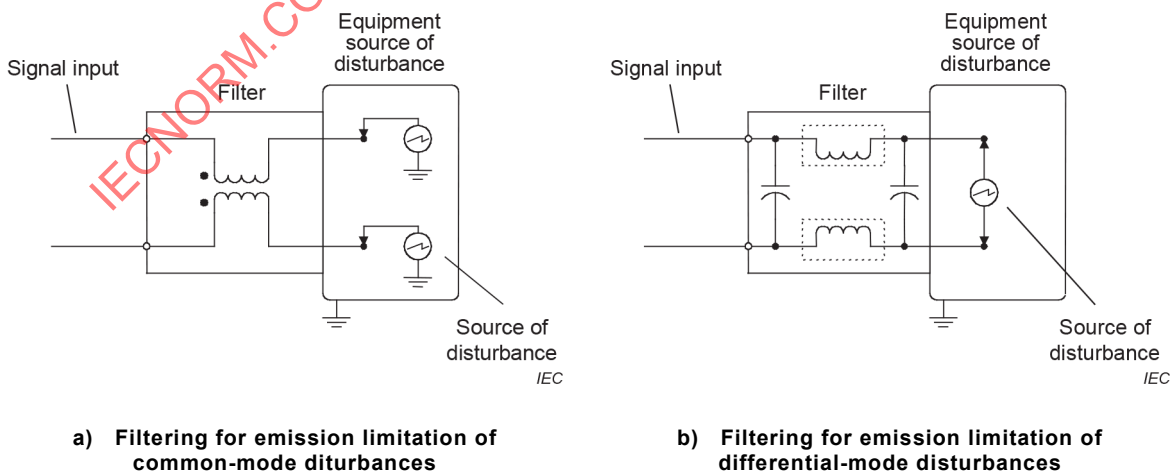


Figure 11 – Reduction of electromagnetic disturbances in the power network and the environment

With reference to a specific functional requirement, a detailed analysis is necessary, concerning

- the characteristics of disturbance sources (continuous or transient type, frequency range, etc.);
- the type of disturbances (common mode, differential mode, mixed type);
- the necessary attenuation (value related to the frequency range);
- the application conditions (characteristics and topology of the circuit to be filtered, environmental conditions, etc.);
- the safety aspects of the installation.

Figure 10 and Figure 11 show the functional tasks of filters with reference to disturbances appearing in common mode and in differential mode. Generally, these two types of disturbances are present at the same time, and the same filtering device can limit them both.

## **7.4 Additional filtering concerns**

### **7.4.1 Technical aspects**

EMC filters are often subjected to much higher power than conventional filters. Since, for instance, power-line filters have to accommodate the normal power levels, they often will be larger in size and the high-power levels can cause a non-linear response as a result of saturation.

Often the energy spectrum of the disturbance is much broader than the energy spectrum of the power, control or signal. In some cases, filtering can be performed in several stages, each one adapted to a different band.

The design of communications filters is premised on impedance matching. In power lines in particular, this is not possible, since power lines are designed to be efficient solely at the power frequency. Thus mismatch often plays a very detrimental role, namely, a drastic reduction of the claimed or expected filtering and, quite often, the occurrence of pronounced ringing.

High-peaked impulse noise combines the high energy of the noise with a very broad frequency spectrum. The presence of non-linear materials in the filter's inductive components should be taken into consideration.

Cascaded filters shall be designed carefully so as to avoid any detrimental interactions.

### **7.4.2 Economic aspects**

There are many alternatives to elimination or mitigation of disturbances. The decision of the most reasonable means can be based on the maximum benefit-to-cost ratio, with the benefit possibly being not much more than what is necessary. No specific single rule can be given for the decision involved, since it depends on the circumstances of the particular system under consideration and its noise environment. Rather, familiarity with all aspects of disturbance elimination and suppression is important. Filtering is quite often the most economical remedy. Filters are usually the preferred means to eliminate differential mode disturbances. The introduction of a filter close to the source can save on costly separation of wiring or on screening if the only concern is conducted disturbances.

## 7.5 Selection criteria

### 7.5.1 General

Filters should be selected and used judiciously. As in all cases of an installation including potentially sensitive equipment, it is desirable that the equipment be intrinsically immune to disturbances and thus perform satisfactorily without the use of external filters or other extensive and perhaps expensive mitigation means. However, when an external filtering action becomes necessary, filters shall be applied in accordance with the principles and guidance provided in this document, in order to ensure proper disturbance mitigation. The first step in the process is to determine the nature of the disturbances against which the protection is necessary:

- frequency range;
- amplitude over the frequency range;
- intentional signal characteristics.

It is then possible to refer to the manufacturer's documentation. This effective application can then be achieved by referring to the filter manufacturer's documentation and tests, in order to determine whether or not the product meets the particular needs of the application. The completed filter installation shall be checked by performing final tests with the filter installed and operating as intended. If this is not possible, verification can be performed on a partial system where these operating conditions could be emulated.

Filters available on the market should be expected to meet the particular needs of the application with a reasonable EMC margin. A reasonable but misguided quest for economy could result in low-cost but less effective filters; nevertheless, one which will provide a sufficient margin should be selected. The following circuit and filter characteristics, common to all applications, should be carefully considered in the filter selection.

### 7.5.2 Voltage rating

Filters for the different rated voltage of the power supply are available on the market, such as 125 V, 250 V, 380 V or 440 V (see IEC 60939-2). Some manufacturers specify permissible overvoltage conditions related to a limited period of time.

Telecommunication and control line filters with proper rated voltage are available on the market for telephone circuits, digital and analogue circuits, control lines, coaxial lines, etc.

### 7.5.3 Current rating

Power-line filters with a wide range of rated current values are available for different applications: filtering of equipment, filtering for shielded rooms and cabinets, protection of the power network in the installation, etc. Values of rated current frequently used are 1 A, 2 A, 4 A, 6 A, 10 A, 30 A, 100 A; many other values are also available.

Filters for applications on telecommunication and control lines are generally designed for current in the range of hundreds of mA.

### 7.5.4 Duty-cycle and overload operating conditions

These characteristics are mainly applicable to power filters and concern intermittent operation, overloading and possible fault conditions in the power system. Overload conditions can be defined by some manufacturers as over-current related to a specified duration, such as 10 times the rated current for 1 s, 5 times the rated current for 5 s, and so on.

### 7.5.5 Operating frequency and range of frequencies to be filtered

Filters for DC or AC power lines are available as well as filters for the typical communications and signal lines frequencies. Low-pass filters are generally used, so any frequency higher than the operating frequency is filtered. Specific band-pass filters can also be used for telecommunication lines.

### 7.5.6 Voltage drop and signal loss

Power-line filters are characterized by a voltage drop depending on the load condition; at rated current this voltage drop is generally in the order of 1 % of the rated voltage or less. The voltage drop of the filter is referred to the rated current and power frequency and includes the drop across both lines of the power supply circuit.

Filters for telecommunication and control lines can produce signal loss. Values less than 1 dB, required for a proper line impedance termination condition, are generally specified by the manufacturers in the bandwidth of the signal.

### 7.5.7 Ambient temperature range

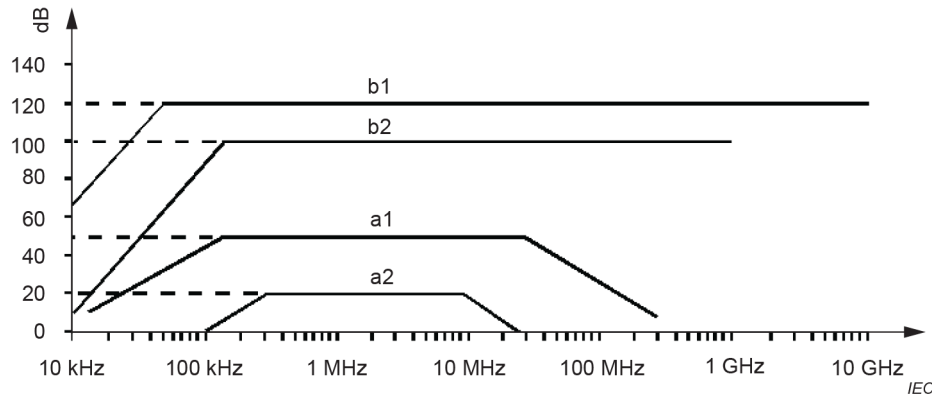
Several climatic categories are defined in IEC 60939-2. A temperature range frequently specified by manufacturers is  $-25\text{ °C}$  to  $+85\text{ °C}$ . Due to their power dissipation, power-line filters can exhibit some casing temperature rise, for instance up to  $10\text{ °C}$ . In an assembly design, this parameter should be considered for a possible influence on adjacent components.

### 7.5.8 Insertion loss and attenuation

The insertion loss, attenuation of common-mode disturbances (line-to-earth) and differential-mode disturbances (line-to-line) are dependent on the frequency and on the operating conditions.

Filters in a wide range of performances are available on the market for the different applications. Limited performances are provided by general application filters, such as in the order of 20 dB to 50 dB for common-mode and differential-mode disturbances in the frequency range 0,1 MHz to 100 MHz. With stringent mounting rules (see 7.6), higher levels of insertion loss are provided by filters for shielded rooms and cabinets; a performance of 80 dB to 120 dB is typical in the frequency range from some tens or hundreds of kHz to 1 GHz or more (Figure 12).

The insertion loss of filters is typically designed and measured with the input and output terminated in an impedance of  $50\ \Omega$ . In this case, the filter insertion loss can be anywhere from 80 dB to 120 dB. However, in the actual installation the line impedance can deviate from  $50\ \Omega$  with an accompanying degradation in the specified insertion loss.



**Key**

- a1, a2 Low-cost filters for general application
- b1, b2 Filters for shielded rooms and cabinets

**Figure 12 – Examples of insertion loss characteristics of AC/DC power port filters**

**7.5.9 Withstand voltage**

Filters shall be selected with proper withstand voltage corresponding to the line characteristics. Power-line filters are generally characterized by different values of line-to-line and line-to-earth, DC or AC withstand voltage; values starting from 1 000 V DC are generally specified by the manufacturer. Test voltages of power-line filters for HF disturbances are specified in IEC 60939-2. For instance, insulation to earth of 2 000 V or greater is recommended for power-line filters with a rated voltage of 125 V or more. Telecommunication or control-line filters generally present lower withstand voltages.

When filtering power or signal lines affected by transient overvoltages, attention shall be paid to the surge withstand capabilities, in common mode and differential mode; the adoption of SPDs can be necessary to protect the filter and the line.

**7.5.10 Attenuation of HF transient disturbances**

The attenuation of transient disturbances (surges, damped oscillatory, fast transients, etc.) depends on their frequency content, the equivalent impedance of the line at the frequency of interest and the impedance of the load.

The attenuation of high-energy surges, including unidirectional surges, is generally low or insignificant; the attenuation of fast transients or oscillations in the range of MHz is better, generally of the order of a few tens of dB. These attenuation levels are generally not specified by the manufacturers of filters. For filtering power or signal lines subjected to high-energy surges, specific filters with built-in transient suppression devices are available on the market; standard filters complemented by suitable overvoltage protection can also be used.

**7.5.11 Leakage current to protective earthing conductor**

The shunt capacitors of the power-line filters cause a steady-state leakage current into the protective-earthing conductor. This current, combined with the contribution of the protected apparatus itself, cannot exceed the safety limits set for the different applications. For instance, IEC 60335-1 specifies current limits for domestic household appliances in the range 0,5 mA to 5 mA. In order to allow the application of safety rules for equipment and installations, the leakage current of the different filters should be taken into consideration in accordance with applicable electrical installation requirements.

Filters for permanently wired shielded enclosures possess values of leakage current of the order of a small percentage of the rated current; these values imply a dedicated low-impedance connection to earth, to avoid unsafe voltages.

### 7.5.12 Permissible reactive current

The reactive current of power-line filters for shielded enclosures, cabinets, networks, etc., can be a significant portion of the rated current. This consideration applies especially to filters incorporating high values of capacitance, as in the case of filters for shielded rooms and cabinets, for which the reactive current and possible imbalance should be taken into consideration.

The reactive current is related to the line voltage and is not dependent on the load condition; it shall be considered in the design of the power supply network, with particular care for special cases, such as the use of uninterruptible power supply systems.

## 7.6 Filter installation

### 7.6.1 General

When using filters, proper installation is essential to achieve good results; mounting techniques become critical at high frequencies. A wide range of practical solutions is available for power-line filters, for instance:

- built-in connector, also with fuse holders and main switch;
- sealed in a plastic or metal case, for printed-circuit-board mounting;
- metal case with earth terminal, connections by fast-on or screws, etc.

Typical filters for installation on shielded rooms (both power supply and telecommunication or control lines) present a feed-through construction for mounting on a metal plate; surfaces should be prepared before the installation of filters to ensure good electrical bonding and to avoid corrosion.

As a general rule, particularly for high-frequency disturbances, filters should be located as near as possible to the apparatus, which is the source or victim, to minimize the impedance of the connection. Filters can be enclosed in the apparatus cubicle or mounted in a dedicated unit installed in its proximity. Filter installation shall be consistent with the overall shield topology.

### 7.6.2 Installation and mounting techniques

If filter circuits consist of individual components, such as capacitors, chokes and resistors, the following shall be considered:

- components shall be arranged along the line to avoid capacitive and inductive coupling between components and between filter inputs and outputs;
- filters shall be well screened to prevent coupling between filter inputs and outputs;
- an important safety consideration is related to the selection of the capacitors providing decoupling to earth. These capacitors shall not become short circuits when damaged;
- since attenuation of a filter circuit in the MHz range is primarily determined by the capacitors connected to earth, the connecting leads of the capacitors shall be as short as possible;
- filter circuits that are to be installed in devices with limited available space shall be screened consistent with the shield topology;
- the metallic filter cases shall have a non-corroding surface in order to ensure a low contact resistance of the case to the interface with the victim apparatus throughout an extensive period of time;
- some filter circuits that have been combined to form a filter could be subjected to different disturbance levels, or could be intended for apparatus with different immunity levels. They are therefore also designed for different degrees of attenuation. These filter circuits shall be decoupled from each other by screening.

### 7.6.3 Wiring

Physical separation of input and output lines is facilitated by the feed-through mounting technique of the filters. Inputs and outputs of filters should be arranged as far apart as possible; leads from the input and output side should never be in the same bundle.

If screened conductors are to be connected to the filter case, coaxial screw-type connections should be used. The mounting of a filter is often more important than the type of filter. Poor mounting of an otherwise good filter will produce poor filtering. The filter earth connection impedance shall be as low as possible to avoid the generation of disturbances that would otherwise be applied in common mode to the apparatus to be protected. See Figure 13 and Figure 14 for examples.

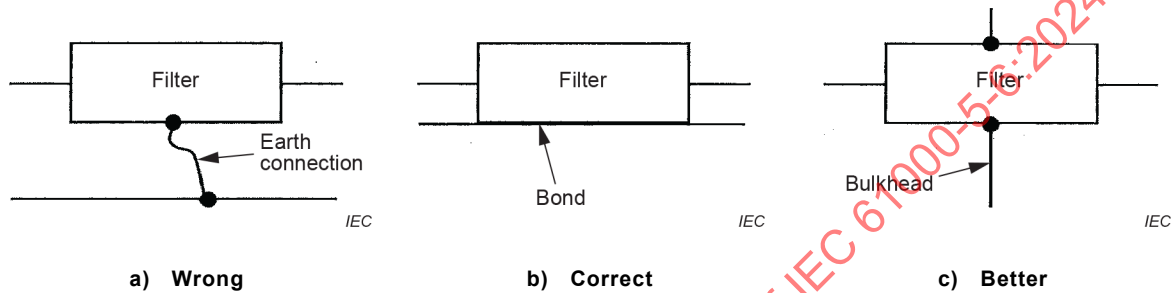


Figure 13 – Mounting of filters

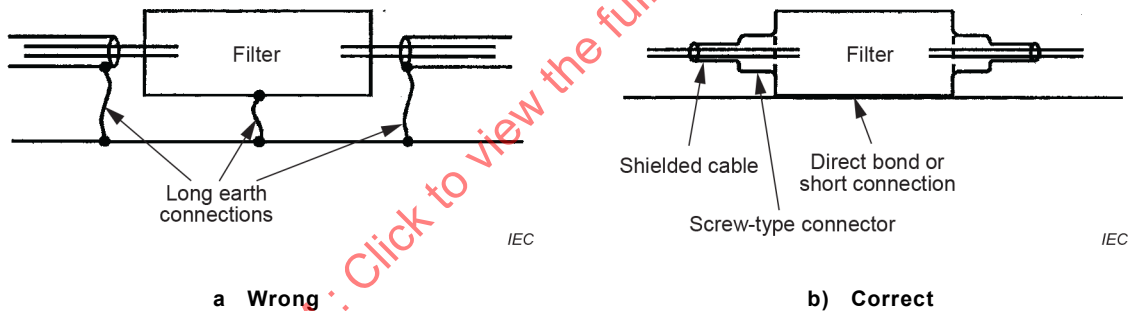


Figure 14 – Connection of screened cables

### 7.6.4 Installation of cabinet filters

When an installation includes the provision of cabinets or cubicles, in which several individual apparatuses will be operating, these cabinets become the responsibility of the installer, in contrast with the situation where a complete cabinet is supplied by a manufacturer.

There can be situations where the installer will be expected to provide filters where the installation wiring interfaces with this cabinet or cubicle. Figure 15 illustrates the integration of filters within a cabinet, and Figure 16 illustrates an arrangement with a separate, dedicated filter unit installed adjacent to an equipment cabinet.

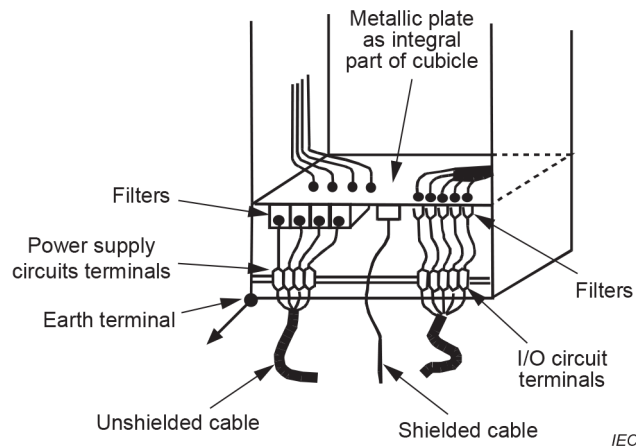


Figure 15 – Example of integration of filters inside an equipment cabinet

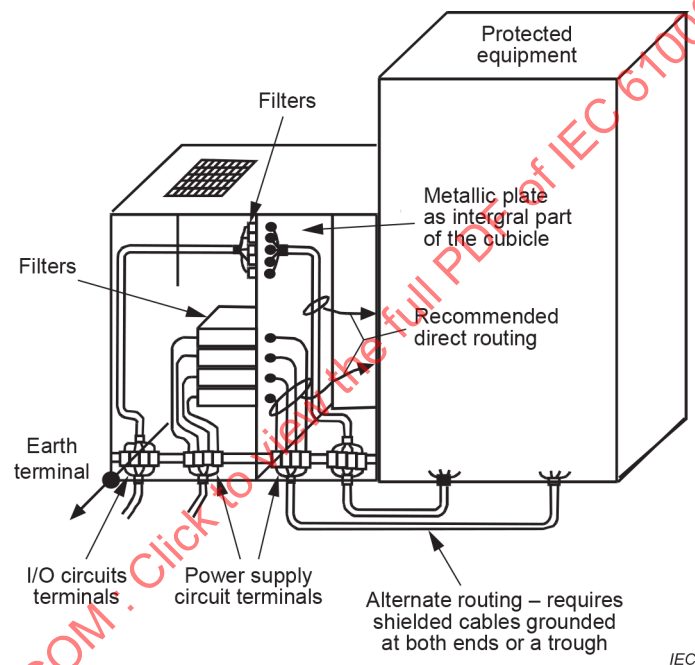


Figure 16 – Example of filter mounting in a dedicated unit

## 7.7 Filter testing

### 7.7.1 General considerations

Subclause 7.7 addresses testing procedures for installations that include filters, but not test procedures associated with incoming reception or performance verification of filters as loose components. Consequently, the test procedures for the following parameters – essential as prerequisites for a successful system design – will not be discussed here as they are considered to be routine tests on components, not installations:

- voltage and current rating;
- duty cycle and overload conditions;
- voltage drop (power-line filters) and signal loss (telecommunications and control filters);
- climatic conditions.

Performance of filters should be verified after they are installed in the equipment or environment for which they are intended. The effectiveness of the earth connection should be assessed by measuring it by an HF conducted test. Correct installation and connections should be checked with the filters in operation, for the absence of any oscillation. The attenuation tests for transient disturbances should be made on installed filters, as described in 7.7.4.

### 7.7.2 Insulation to earth and withstand voltage of installed filters

Should an insulation test be advisable (in the case of tight clearances, for instance), the test procedure specified in IEC 60939-1 for testing insulation resistance and dielectric strength applies to both power port filters and telecommunication and control port filters.

Concerning the 1,2/50  $\mu$ s surge test: the test generator and test procedure specified in IEC 61000-4-5 are applicable as follows. The combination wave test generator (1,2/50 to 8/20) defined in IEC 61000-4-5 should be used, with the appropriate internal impedances.

The insulation test shall be carried out on the filter under no-load condition, and not connected to power supply or signal sources. The test generator can therefore be directly connected to the filter under test without using any coupling/decoupling network. The output terminals of the filter under test should be maintained opened and isolated from earth. No sign of breakdown or flashover is allowed; any abrupt alteration in the surge waveform observed at the input terminal of the filter should therefore be investigated.

If surge testing is to be carried out in situ, the following safety procedures should be implemented:

- all equipment loads should be disconnected;
- everyone in the building should be warned and instructed in safety procedures;
- precautions should be taken so that transients are not inadvertently injected into circuits not under test.

### 7.7.3 Insertion loss

Refer to CISPR 17 for a detailed procedure of this type of tests.

### 7.7.4 Attenuation of HF transient disturbances

The test procedures listed in the next paragraph apply to power-port filters and to telecommunication and control-port filters. The filter working conditions should be simulated during the test; proper voltage and current should be supplied to the filter, by using an auxiliary circuit including power supply source and load. The following test generators should be used for a comprehensive test of the filter installation:

- electrical fast transient/burst generator;
- combination wave generator 1,2/50 to 8/20, with effective internal impedance of 2  $\Omega$ , 12  $\Omega$  and 40  $\Omega$ ;
- ring wave generator, with effective internal impedance of 12  $\Omega$ ;
- damped oscillatory wave generator.

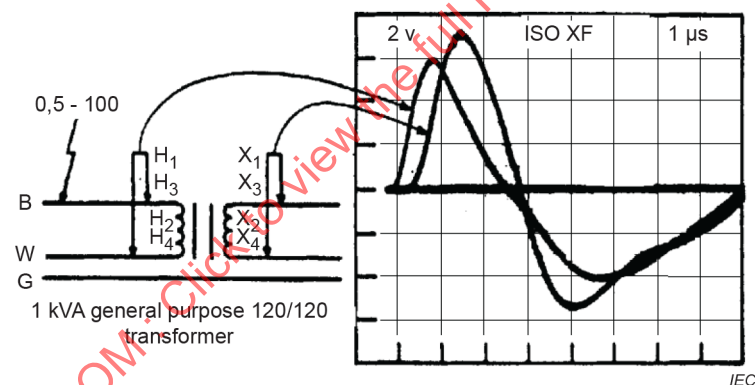
The characteristics and performances of the test generators are specified in the relevant basic standards IEC 61000-4-4, IEC 61000-4-5 and IEC 61000-4-12. The maximum test level should be selected among the preferred values specified in IEC 61000-4-4, IEC 61000-4-5 and IEC 61000-4-12 but should never exceed the rated withstand voltage of the filter. The test voltage should first be set with the test generator under no-load condition; then the test voltage will be applied to the input terminals of the filter under test and recorded. During the test, no malfunction of the system should be observed. Alternately, the residual voltage at the output terminals will be recorded, for both common-mode and differential-mode test conditions, to verify the attenuation of the filter as installed.

## 8 Decoupling devices

### 8.1 Isolation transformers

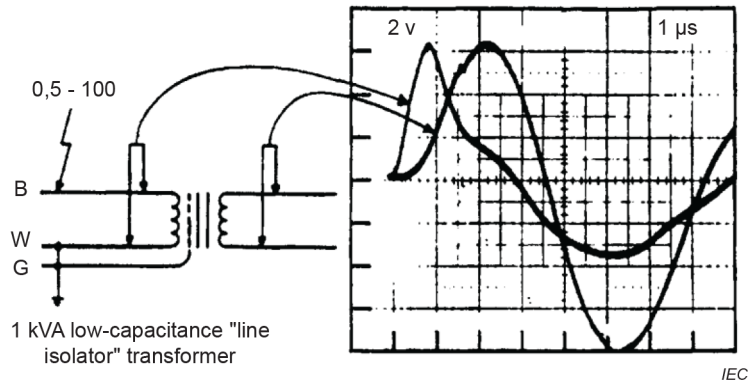
Isolation transformers are useful devices to break the conductive continuity of a circuit while maintaining passage of differential-mode signals (here, "signals" are understood as normal operating communication signals or AC/DC power). Depending upon their application, that is, the signals to be passed through, their frequency bandpass ranges over a few kHz. Even at higher frequencies (tens of kHz), some isolation transformers are still capable of passing a substantial part of the primary differential voltage into the secondary winding.

A common misconception is that "isolation" transformers attenuate all transient overvoltages, without recognizing that, in most cases, this performance is limited to common mode conducted disturbances. Figure 17 illustrates how a general-purpose transformer allows an impinging surge in the differential mode to pass essentially unattenuated onto a loaded secondary circuit. The only attenuation that should be expected is that corresponding to the voltage drop associated with the equivalent series impedance of the transformer. Even worse, some configurations giving rise to resonances can enhance the voltage across the secondary. Figure 18 illustrates how a transformer built with an inter-winding screen and advertised as a "super-isolation" transformer can in fact produce a higher voltage across the secondary if improperly applied with an expectation of differential-mode decoupling. The measurement, as shown in Figure 18, illustrates the misconception that isolation transformers decouple all surges: it is only true for common mode, and only up to some frequency, above which inter-winding capacitance becomes significant and the decoupling effect degrades. See Figure 19 for an indication of a screen connection.

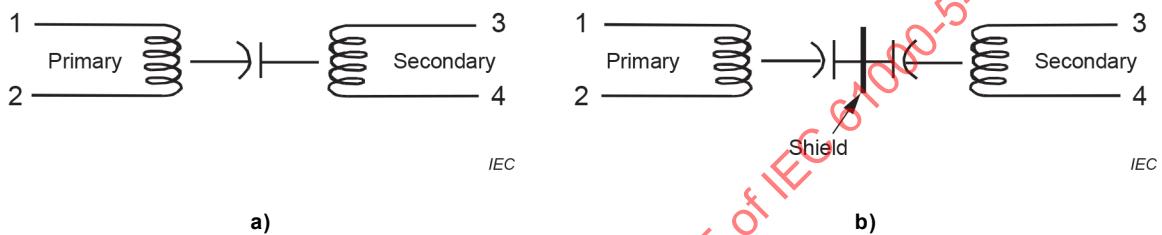


**Figure 17 – Laboratory measurement showing the propagation of a 0,5 μs to 100 kHz ring wave, applied in differential mode, through an ordinary isolation transformer**

Note that, in Figure 18, the secondary has not been bonded to the earthing system. Such an arrangement is generally permitted only when the transformer is part of an apparatus. When the transformer is part of the fixed wiring, bonding of the secondary is generally mandated by national codes, as shown in Figure 17. The proper application of an isolation transformer, therefore, is limited to breaking a common-mode circuit at low frequencies. In that role, it finds many applications for power circuits as well as communications circuits, especially when linking systems that do not have a common earthing arrangement. Of course, the insulation level between primary and secondary shall take into consideration the magnitude of the overvoltages that can occur in the specific application. The stray capacitance between primary and secondary of the isolation transformer can be reduced by interposing a screen. The current through the inter-winding capacitance is most often a common-mode current from 1 and 2 to 3 and 4 in Figure 19 a).



**Figure 18 – Propagation of a 0,5 μs to 100 kHz ring wave operating in the differential mode through a "line isolator" transformer**



**Figure 19 – Inter-winding coupling in an isolation transformer**

The main benefit of the screen in Figure 19 b) is to provide a path for that common-mode current around the secondary winding. Furthermore, this path should have a low transfer impedance i.e., the ratio of output voltage to input current, with respect to the electronics supplied by the secondary. Therefore, the screen and also the transformer core should be connected to the common earthing system via the shortest bond, if such a system is present, as shown in Figure 18. If such a common earthing system is not present, the screen and core should be earthed to the earthing system at the secondary or to the low-voltage side (4) of the secondary in Figure 19.

If the transformer contains more than one screen, at least one screen should be connected as described above. The additional screens are often designed to reduce high-frequency capacitive differential-mode-to-differential mode (DM-DM) crosstalk. Their earthing strongly depends on the actual layout and design. Inductive DM-DM crosstalk (Figure 17 and Figure 18) cannot be reduced by additional screens. To this end, filters or SPDs should be applied.

There are a variety of devices available for power-line conditioning which can provide varying levels of decoupling. These devices fall into three general classifications: line isolation, voltage regulation, or power factor correction. Many of the products available have or claim to have some combination of more than one of these three capabilities.

Line-voltage regulators can take a variety of forms. For example, some of the oldest technology used some form of saturable reactor or inductor. These devices either change the phase relationship of the lines to adjust the output voltage or they adjust the saturation of the magnetic cores to regulate the output. Devices using these technologies do not usually provide any significant level of decoupling and can generate non-linear components.

Another form of line voltage regulators uses various forms of transformer configurations, for example, ferro-resonant transformers and tap-changing transformers. Of these devices the ferro-resonant transformer provides a certain amount of isolation by virtue of its inherent operating principle. The decoupling capabilities of both these transformer types can be improved by the implementation of one or more of inter-winding screens, filters and SPDs.

There is also a family of line regulators that convert the incoming utility AC waveform to DC and then reconvert the DC back to an AC waveform. The technologies used to accomplish this vary, and it is beyond the scope of this document to describe them in detail. The decoupling provided by this class of product is typically quite high if the device is properly installed.

## 8.2 Motor-generator sets

Motor generators are another form of decoupling power-conditioning device. They completely isolate their loads from the utility service. Motor generators are configured so that the utility service drives the motor section of the device. The motor, through some arrangement of mechanical linkage, drives the generator, which in turn powers the load(s). Therefore, there is no electrical connection between the utility and the load. In special cases, it might be necessary to further enhance the decoupling by providing a non-conductive shaft for coupling the two machines. A conductive linkage can, in fact, enhance the coupled energy into the facility.

Usually motor-generators can only support the loads for a relatively short time when utility power is lost. This is because, upon loss of utility power to the motor, the only source of energy to the device is the inertial energy of its rotating components. This time can be extended somewhat through the use of an inertial mass, such as a flywheel.

Under normal conditions, there are no problems with output waveform distortions; however, there are some areas for the installation designer to be aware of. Some other areas of concern would be output voltage and frequency regulation and the overall quality of the delivered power.

## 8.3 Engine generators

Engine generators are not dependent at all on the local utility service. As the prime mover, the engine drives a generator which supplies the electrical energy to the loads. Energy to the prime mover is usually some form of fossil fuel, for example, diesel.

Often engine generators are used as an emergency backup to the utility service. An important economic consideration in these cases is whether or not it is necessary to provide an uninterrupted transition from utility service to engine generator service. If such a transition is desirable, then provisions shall be made to sense when the utility service is failing so that the engine generator can be started and the loads switched from the utility. It should be noted that engine generators require ventilation and thereby create possible penetrations and can require special assessment procedures.

## 8.4 Uninterruptible power supply (UPS)

The UPS is a class of power conditioning device which has the following general attributes:

- it is capable of sustaining power to a load after the loss of utility service;
- it can provide isolation from the service utility feed.

UPS-type devices typically use batteries as an emergency source of energy should the utility service fall below certain preset magnitudes. The length of time UPS devices can sustain the load is dependent upon the load demand and the size of the battery bank associated with the UPS.

The degree of isolation provided is determined by several factors in the intrinsic design of the particular model of UPS. There are two generic design approaches to UPS configurations, usually referred to as either off-line UPS or on-line UPS.

Off-line UPS allows a utility power to service the load under normal conditions. During periods when the UPS detects certain abnormalities in the utility service, the device switches to inverter output.

On-line UPS normally services the load from its inverter output and will only switch to utility service if the device detects an error in its internal circuitry or is manually forced to switch.

In the case of off-line UPS the degree of isolation will depend on what provisions are made to condition the utility service in the normal mode of operation of the UPS. In the case of the on-line UPS there is a reasonably high degree of load isolation from the utility service intrinsic in the UPS design. This is a result of the UPS device converting the incoming utility AC service to a DC voltage and then reconverting the DC voltage to a conditioned AC voltage which is supplied to the load. For an off-line inverter type, the isolation is frequently provided by a by-pass isolation transformer inside the UPS.

There are several attributes concerning UPS that a designer should consider. Several have already been implied, such as the autonomy time duration desired and whether to choose an on-line or an off-line device. Some others are:

- output impedance of the UPS device. When operating in the UPS mode, these devices will have higher output impedance than the utility service. Consequently, the power quality can be affected by the load conditions such as harmonic emissions, switching, etc.;
- quality of the UPS output waveform. Various methods are employed to reconstruct the AC sine wave from a DC source, for example, pulse-width modulation, static inverters, ferro-resonant transformers, etc. Some or all of these methods can introduce certain amounts of waveform distortion. In the process of selecting the proper UPS size, both the rated power in the power system and the current peak, including the harmonic effect of the loads, are to be considered.

### 8.5 Optical links

The ultimate decoupling method is to eliminate electrically conducting connections across an interface. For low-energy signals, this decoupling can be obtained by optical links, either in the form of an opto-coupler or a system with optical fibre transmission. In opto-couplers, a modulated light beam is transmitted across a short air gap in a package of the type used for discrete semiconductor components. Opto-couplers are generally incorporated in an apparatus and, therefore, are not addressed here in detail. Incidentally, the capacitance of opto-couplers should not be ignored when relying on a built-in device to perform the interface. When fibre links are used in an installation, similar mounting procedures as described in 6.4.7 should be applied.

Commercial fibre optic data transmission hardware has now reached maturity and has become a cost-effective means of decoupling for EMC purposes. In contrast with telecom applications that provide data transmission over considerable distances, decoupling fibre optics only have to be long enough to provide dielectric strength commensurate with the application. However, if the transducers at the two ends of the fibre link are susceptible to EM disturbances, the expected result might not be achieved, thereby negating the potential effectiveness of the fibre. Fibre bundles can be sensitive to mechanical vibrations or to ionizing radiation. Some designs include a metal wire to facilitate pulling the bundle or provide an easy communication means for installers at the two ends of the bundle or metal cladding to provide mechanical strength. The presence of such metallic elements will likely defeat the intended decoupling.

## 9 Surge-protective devices

### 9.1 General

SPDs are used in power circuits as well as communication circuits to protect equipment from transient, high-frequency disturbances in the form of surge voltages or surge currents. In contrast to filters that are mostly used for mitigating continuous disturbances, SPDs are designed for mitigating surges that occur as single events (possibly as bursts) in a random, generally unpredictable manner. Often, SPDs are used in combination with filters.

The general approach to mitigation of surges is to establish a parallel path that can divert the surge current from the equipment, in a low-impedance path that will produce a relatively low voltage drop across the terminals of the protected apparatus. Thus, most SPDs are connected in shunt with the line, one component for differential mode and two components for common mode. Occasionally, some series elements can contribute to the mitigation by selectively limiting the propagation of the surge towards the protected apparatus. Mitigation can be performed in several stages:

- relatively slow-response, high-energy device;
- relatively faster response, with limited energy capability;
- final filtering or limiting of the residual overvoltage from upstream SPDs.

A comprehensive application guide on SPDs is beyond the scope of this document and involves a detailed knowledge of the surge environment ("the threat"), accurate knowledge of the apparatus immunity (sometimes difficult to determine), and of the capabilities and side-effects of various types of SPDs. Here a broad discussion of the issues rather than specific recommendations for a particular installation is provided. Several documents in the IEC deal with this issue, for example IEC TR 62066, which addresses in detail the application and installation of SPDs. In addition, for the specification of SPDs to protect against the HEMP conducted environment, IEC 61000-5-5 will be useful.

The discussion of SPD application is presented from the point of view of enhancing EMC in low-voltage systems, both power and communications. This point of view involves two functions of an SPD:

- direct equipment protection by mitigation of stresses imposed on equipment by the voltages associated with the impinging surges;
- indirect equipment protection by prevention of large surge currents within the building wiring that would induce disturbing or destructive voltages in adjacent circuits.

## 9.2 Direct equipment protection

Direct equipment protection is the prime motivation for installing SPDs in power and communication circuits. This protective function can be accomplished at many points of the installation, including the apparatus itself. In that case, the SPD is under the control of the apparatus manufacturer and might appear to be outside of the scope of this document. However, as discussed in 9.4, the presence of such an SPD in an apparatus can impact the overall EMC effectiveness of the installation.

Based on the postulate that surges originate mostly from the outside, an obvious location for installing an SPD is at the entrance point of the building. This provision of an SPD is applicable to the entrance of the power service as well as the entrance of a communications service (telephone, TV, telemetry). However, two other sources of surges should not be overlooked:

- switching surges created by turning power on or off within the installation (a normal occurrence), or by fault clearing with fuses or circuit breakers (a rare but potentially troublesome occurrence);
- surges associated with direct lightning strikes to the building, with the lightning current seeking a direct path toward earth through the earthing arrangement of the building. A second possibility is an indirect path through the power and communications services that carry the surge current from the building toward the remote earthed point of these services via the service entrance SPDs.

In spite of the protection offered by an SPD installed at the service entrance, many installations do not apply this benefit, claiming that their experience of no significant damage does not justify the expense. In some countries or localities, certain classes of installations are required to include this type of protection and can require the SPD to be monitored. Thus, in this case as in other examples, the degree of protection installed will depend on the value of the equipment to be protected and the risk that the facility owner is willing to accept.

Consequently, awareness of the risks of surge damage will frequently result in the provision of an SPD at some point of the installation. Commercial devices are available for installation at the service entrance, at service sub-panels, and as plug-in devices that can be inserted in receptacles where "sensitive" equipment is connected. A concern for this type of device is assurance that the function is maintained. Some designs include a disconnect in case of SPD failure which removes the failed SPD from the line, ensuring continuing operation of the load, but without surge protection. An indication of that condition can be provided by the SPD manufacturer (a requirement in some countries) and can be monitored.

This unregulated situation produces some confusion as no overall guidance is provided to the end-user on the performance-effective and cost-effective selection of multiple SPDs. Within the limited scope of this discussion, the following factors should be considered, with further details to be found in documents currently under development by the IEC.

- Select an SPD with voltage-limiting characteristics consistent with the level of protection desired within the system (the compatibility level in EMC terms) to achieve the prime function of the SPD.
- Select an SPD with steady-state voltage rating consistent with the maximum continuous operating voltage occurring in the system, to avoid overstressing or premature ageing of the SPD under long-term overvoltages. Select an SPD with current (energy) handling capability consistent with the current (energy) that the surge source can deliver to the SPD, to ensure long life of the SPD under repeated surge occurrences. Install SPDs consistent with the overall protection topology. That is, bonding and interconnection should be applied so that the topology is not compromised.

### 9.3 Installation of multiple SPDs

With the general use of SPDs, the situation is often created where several SPDs are connected across the power line, effectively in parallel (all in a line-to-neutral configuration, or in a configuration involving a line-to-earth SPD, followed by line-to-neutral SPDs), with only the wiring impedance providing a separation of the SPDs. This situation is generally described as "cascaded SPDs", and can be the result of a deliberate, well-designed plan, or of the uncontrolled presence of SPDs.

In a well-designed plan, also designated as a "co-ordinated cascade", the SPD located upstream, presumably at the service entrance, is selected with ratings consistent with the expected impinging surges. This is intended to divert most of that surge to earth at that point, leaving only a residual surge current to propagate inside the building. Downstream, additional SPDs can be installed to deal with the residual surge, or any surge that might be generated within the building and propagate toward specific, sensitive load equipment without the benefit of the SPD located at the service entrance. (Ultimately, the service entrance could have some action on these internally generated surges, but that action would be delayed by the round-trip time and degraded by the wiring impedance from the origin of the surge to the SPD.) These additional SPDs (which can have different characteristics) are therefore sized to handle the residual surge at a lower cost than the full-sized upstream SPD. However, this intended, deliberate unequal sharing of the surge might not be achieved if the limiting voltage of the downstream SPD is significantly lower than that of the upstream SPD. If this were the case, the downstream SPD would "draw" most of the residual surge, leaving the higher-limiting upstream SPD essentially unused, contrary to the expectation that this upstream SPD would absorb most of the surge energy. Of course, the upstream SPD will provide some degree of protection to the remainder of the equipment within the facility by virtue of its having lowered the initial surge at the building interface.

There are virtually millions of residential installations where no SPD is provided at the service entrance, which means that the built-in SPDs of the apparatus or the plug-in SPDs installed by the occupant are in fact drawing the surge current into themselves. Field experience shows that even where these internal SPDs have only a moderate surge-carrying capacity, their failure rate is not conspicuously objectionable. Thus, the scenario of an uncoordinated cascade, where the service entrance SPD does very little, is not a major threat to the survival of the equipment inside the building – as long as the apparatus involves only one port (generally the AC power port). Subclause 9.4 describes a scenario where multiport apparatus might be in jeopardy. In addition to this side-effect, the uncoordinated cascade is a waste of resources, as an SPD with higher limiting voltage at the service entrance is not providing any significant relief to the low-limiting SPDs built in the apparatus or plugged in by the occupant.

#### **9.4 Side-effects of uncoordinated cascades**

In an uncoordinated cascade, there is a greater likelihood that the SPD with the lowest limiting voltage will be the one installed at the end of a branch circuit. This is a result of the apparent trend of manufacturers and installation designers to expect surge voltages which are higher at the entrance of a building than inside the building. For many years, this perception was encouraged by the "staircase" of "installation categories" in IEC 60664 (1980) (later changed to "overvoltage categories"). Research on the coordination of cascades has shown that in such cases, a substantial part of the surge current is left to flow within the building, creating EM fields that couple disturbances in adjacent circuits, instead of having the surge current diverted at the service entrance. If the SPDs inside the building include, as some do, diversion of the surge current toward the protective earth conductor, the user-end of that conductor will be raised to a potential higher than that of adjacent earthed metal, an undesirable and potentially damaging situation. This is merely an example of an application of SPDs that is inconsistent with the overall protection topology.

#### **9.5 Typical protective devices**

##### **9.5.1 General**

SPDs that can be useful to an installer include a variety of technologies, as listed in 9.5.2 and 9.5.3. Detailed information on the application of these devices is addressed in other documents under development and is not included in the scope of the present document.

##### **9.5.2 Voltage-limiting type SPDs**

This type of SPD comprises at least one non-linear component that has a high impedance when no surge is present but will reduce its impedance progressively with increased surge current and voltage. Common examples of components used as non-linear devices for this function are metal-oxide varistors and silicon avalanche diodes. A voltage-limiting type SPD has a continuous voltage versus current characteristic. Because this type of device maintains its limiting voltage while conducting the surge current, significant power is dissipated in the non-linear component, which shall be sized properly for the specific application.

##### **9.5.3 Voltage-switching type SPDs**

This type of SPD comprises at least one non-linear component that has a high impedance when no surge is present but can have a sudden change in impedance to a low value in response to a voltage surge. Common examples that use non-linear devices for this function are spark gaps, gas tubes and thyristors. These SPDs are sometimes called "crowbar type". A voltage-switching device has a discontinuous voltage versus current characteristic. In some cases, the abrupt change in impedance can produce high rates of current changes in the protected circuit that can induce significant disturbances in adjacent circuits.

## Annex A (informative)

### Resilience-based approach for the mitigation of external high-power electromagnetic environments

#### A.1 Overview

The main body of this document describes protection concepts or a protection-led approach for the mitigation of external electromagnetic influences impinging upon a facility or installation. Annex A introduces the concept of a resilience-based approach which includes protection as an element together with other elements, methods or procedures for the mitigation of external electromagnetic influences. Annex A proposes a framework for managing resilience of an installation from EM disturbances.

This guidance is particularly relevant for transient EM environments or disturbances that are expected to be very infrequent yet have the ability to induce severe effects on electronic systems. High-power electromagnetic (HPEM) environments such as high-altitude electromagnetic pulse (HEMP) and intentional electromagnetic interference (IEMI) are specifically relevant. Whilst these types of disturbances are likely to have high consequential impact, it can be difficult for the facility owner to justify the application of protection-led mitigations.

The guidance is also considered highly applicable for those systems or facilities:

- which are functionally critical and are therefore monitored and maintained such as those deemed as critical infrastructure facilities;
- which are highly interconnected to other systems or other facilities or other infrastructures which can be outside the direct control of the facility operator;
- which are part owned or multi-tenanted where the availability of technological protection measures cannot be assured;
- where the effort and cost of installing protection technology to an existing facility can either outweigh the benefit or where it is impractical to install protection technology.

Ultimately, the vast majority of systems or facilities in a modern infrastructure are not required to remain functional or work through a HEMP or IEMI disturbance but they can be protected sufficiently so that they can be restored in a timely and efficient manner after the event has subsided. However, where human functional safety risks (as defined in IEC 61508-1) have to be reduced to acceptable levels, the EMI protections and mitigations described in this document might not be sufficient, and the electromagnetic resilience approach described in IEEE Std 1848-2020 [1]<sup>1</sup> will also be necessary.

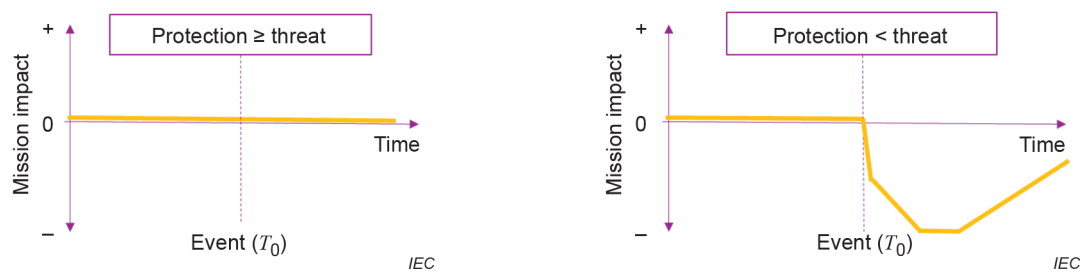
#### A.2 The concept of resilience

##### A.2.1 General

The term resilience, as used in Annex A includes the requirement for protection (withstand) but other attributes are added. A key change here is a shift in emphasis, implied in the protection-led approach from "shall continue to work-through", to a "shall be capable of timely recovery" emphasis in the resilience-based approach. For the resilience-based approach there is an implied acceptance that the mission or function of a system or facility can be affected or disrupted and therefore that prompt restoration and recovery are likely to be required. This difference in concepts is explained in Figure A.1 and Figure A.2.

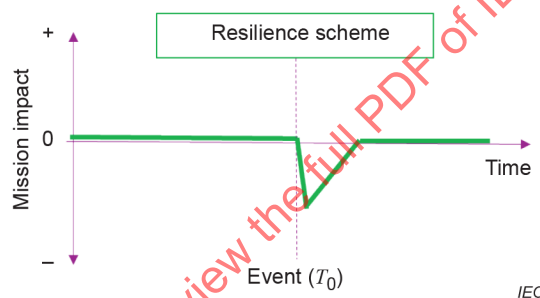
---

<sup>1</sup> Numbers in square brackets refer to the Bibliography.



**Figure A.1 – Protection-led approach**

In Figure A.1 two situations are shown. On the left it is shown that when the protection is adequate the threat is mitigated and no impact on the mission or system is experienced. On the right in Figure A.1 when the protection is not adequate, for example the threat event is much more severe than has been designed for or the protection has degraded and not been maintained, then there is a negative impact on the mission, an outage. Importantly the time to regain full mission function can be considerable because the impact was not anticipated and recovery was not planned.



**Figure A.2 – Resilience-based approach**

In Figure A.2 a conscious effort is made to consider recovery, acknowledging that any protection or preparedness could be inadequate. The shift in emphasis here can mean that the time to recovery of the full mission function can be shorter.

### A.2.2 Discussion on the protection-led approach

The most disruptive of the HPEM environments based on geographical coverage area and intensity is HEMP. The earliest standards for HEMP protection of facilities were developed for military use [2] This is at least partially because the HEMP threat was first acknowledged by the defence or military sector which required a zero-disruption or 'work-through' solution for the HEMP threat.

Military HEMP protection standards exemplified by Mil-Std-188-125 [3] require a high degree of protection. For example, the radiated protection level required at 100 MHz is  $> 80$  dB. This is mainly due to the requirement to work-through HEMP events without any disruption and also due to the inclusion of significant protection margin so that degradation in the protection performance does not impact the ability of the facility to work-through.

The Mil-Std-188-125 [3] work-through approach was developed by and for the military and only for a subset of military systems which are described as "time urgent" and "mission critical". The military HEMP protection-led approach described in Mil-Std-188-125 [3] was developed in the Cold War era when certain highly critical systems absolutely had to survive and function through a HEMP event. The Mil-Std-188-125 [3] approach places a great deal of emphasis on protection technology such as shielding, filtering and transient protection. The testing and evaluation approaches described are tailored to this kind of protection approach.

Military electronic equipment tends to operate in a fixed or well bounded-networked manner and is resilient by design. Military facilities which are EMP protected tend to be continuously staffed with trained professionals who can have dedicated responsibilities for maintenance of the EMP protection.

The concept of a protection-led approach shown in Figure A.1 and described in the main body of this document is known to be very effective as long as it is affordable and the 'as-built' protection is maintained and continuously monitored and assured. This can be very difficult for the situations listed in Clause A.1.

There have been known difficulties in applying the protection-led approach to civilian systems and facilities in particular those that form critical infrastructure.

**A.2.3 Benefits of a resilience-based approach**

A resilience-based approach does not negate the necessity for some protection since damaged components and systems will slow recovery and restoration and therefore damage should be prevented. A resilience-based approach accepts and anticipates that protection can be inadequate, unaffordable or that protection can degrade.

The resilience-based approach is used for many other types of threat. Consider for example the risk of a fire to a populated building, for example a school, hotel or office. Full fire protection of the building or even a zone within a building can be technically feasible but can severely limit accessibility and can be unaffordable. The residual risk that a fire will damage the building or worse claim lives cannot be fully mitigated by protection alone, though protection such as fire-retardant materials, fire-doors and fire suppression systems are likely to be implemented. Because of this residual risk and because it is not necessary for the people at risk to work-through the fire incident, fire and smoke detection is implemented and there will be occasional tests of the system and evacuation drills, essentially training and rehearsal. The fire protection solutions merely slow the spread of the fire to buy time for the emergency services to intervene.

The emphasis in this scheme is in reducing the consequential impact, restoring function and returning to normal operations as quickly as possible. This resilience approach is also followed for cyber threats as it is not possible for cyber security protection designers to keep pace with the speed of evolution of the cyber threat.

The concept of a resilience-based approach to mitigation of HPEM disturbances is fairly new though the United States Department of Homeland Security (DHS) has published a four-level scheme [4], summarized in Table A.1 as follows:

**Table A.1 – Protection levels based on operational criticality**

Protection level	Operational Criticality
Level 1	Lowest cost; longer mission outages permitted
Level 2	Only hours of mission outages are permitted
Level 3	Only minutes of mission outages are permitted
Level 4	Only seconds of mission outages permitted

In the scheme above the protection level assigned to a facility is predicated on the criticality of the mission of the facility articulated as a recovery time.

**A.2.4 Affordability and risk**

Ultimately a protection or resilience scheme has to be affordable. Affordability is subjective but is a function of the cost/impact of failure of the system (risk) during the system lifetime. This can be contrasted against the likelihood that the risk will occur which in turn is a function of the occurrence of the threat.

The cost of EM protection not only includes the up-front or capitalization costs, but also the whole-life costs of the protection scheme which includes the cost of continued assurance and the cost of remedial repairs to a damaged protection scheme.

A modern facility undergoes regular changes or upgrades. For example, in [5] it is recommended that a review and refresh of IT infrastructure be done every two to four years. Other aspects such as new energy efficiency initiatives can also drive the requirement for regular upgrades [6]. This means that infrastructure owners or operators are in an almost constant cycle of upgrades to meet the latest requirements. Unless great care is taken during an upgrade which will inevitably require new penetrations through the protected boundary, a protection scheme can very easily be compromised.

Due to the factors discussed above, "work-through" protection schemes are not widely adopted for HPEM disturbances. Ultimately this is because of uncertainty of the severity and likelihood of the threat, which means that protection for HEMP and IEMI is only applied in very limited cases. The "as-built" and "whole life" costs of protection [7] and the difficulty managing upgrades discourages many from applying protection at all.

#### A.2.5 Appropriate application of a resilience-based approach

The resilience-based approach is not applicable for all systems as there is a clear dependency on system criticality or system availability requirements, or both. See Table A.2

**Table A.2 – Appropriate application of the resilience-based approach**

Acceptable response and recovery time	Weeks	Days	Hours	Minutes	Seconds / work-through
Approach to EM disturbance mitigation	Resilience-based approach	Resilience-based approach	Resilience-based approach	Resilience-based approach has some benefits but protection becomes an important consideration	Protection dominated with margin and redundancy
Reliance on protection technology	Very low	Low – protection from damage unless spares are readily available	Moderate – protection from damage	High – protection from damage; some disruption can be tolerated	Very high – protection from damage and disruption with protection margin
Applicability of detection	Provides benefits in directing first responders	Provides benefits in directing first responders	Provides benefits in directing first responders	Provides benefits in directing first responders	Provides limited benefits <sup>a</sup>
Reliance on first responders for recovery	Low	Moderate – first responders are likely to require their own mitigations	High – first responders are likely to require their own mitigations	High – first responders will require their own mitigations	Low
<sup>a</sup> The resilience-based approach can have benefits to systems in the right hand column of Table A.2 as the approach will enable response and recovery actions in the event that the protection has failed or is unknowingly compromised.					

### A.3 EM resilience model and framework

#### A.3.1 General

In order to systematically apply a resilience-based approach to a system or facility a model of the concept and a framework describing the attributes to be considered are required.

Given that interdependency is a dominating factor in resilience from HEMP threats [8], it is postulated that HEMP and IEMI threats have more in common with today's cyber security threats, particularly those cyber security threats that are a threat to the availability of information, functions and services, such as disruptive computer network attacks.

To this end, in an effort to make use of existing, authoritative and peer reviewed principles and practices developed for cyber threats it is proposed that perhaps the most simple to understand and accessible cyber security approach is the function model described in the National Institute of Standards and Technology (NIST) Cyber Security Framework [9]. The core elements or functions of the framework [10] are shown in Figure A.3.



**Figure A.3 – The five functions of the NIST cyber security framework**

The five functions included in the framework core are:

- 1) identify;
- 2) protect;
- 3) detect;
- 4) respond; and
- 5) recover.

These functions are briefly described in A.3.2 to A.3.6.

#### A.3.2 Identify function

The identify function promotes an organizational understanding to managing risk to systems, people, assets, data, and capabilities. Understanding the business context, the resources that support critical functions, and the related risks enables an organization to focus and prioritize its efforts, in accordance with its risk management strategy and business needs.

#### A.3.3 Protect function

The protect function outlines appropriate safeguards to ensure delivery of critical infrastructure services. The protect function supports the ability to limit or contain the impact of a potential event.

#### **A.3.4 Detect function**

The detect function defines the appropriate activities to identify the occurrence of a cybersecurity event. The detect function enables timely discovery of events.

#### **A.3.5 Respond function**

The respond function includes appropriate activities to take action regarding a detected incident. The respond function supports the ability to contain the impact of a potential incident.

#### **A.3.6 Recover function**

The recover function identifies appropriate activities to maintain plans for resilience and to restore any capabilities or services that were impaired due to an incident. The recover function supports timely recovery to normal operations to reduce the impact from an incident.

The five functions describe activities which are further sub-divided into categories and sub-categories. These are summarised in [11]. These collectively drive outcomes, which in turn lead to successful management of resilience, in the cyber context.

The NIST cyber security framework is highly adaptable and flexible and has been adapted as the basis for an HEMP and IEMI resilience approach described below.

#### **A.3.7 Adaptation of the NIST framework to HPEM resilience**

The five core functions of the NIST cybersecurity function, i.e, identify, protect, detect, respond, and recover, have been adapted in Clause A.4 to fit the needs of a HPEM resilience framework. Using [11], each category and sub-category has been assessed for its relevance for HEMP and IEMI. Where a category or sub-category has been selected the numbering of the category or sub-category has been preserved to enable traceability back to the original framework.

Some of the descriptive language of a category or sub-category has been adapted to fit the needs of the HPEM resilience framework.

The HPEM resilience framework mirrors exactly the five core elements used in the NIST framework. A reduced set of categories and subcategories specific to HPEM resilience has been created. The NIST cybersecurity framework has been developed by many experts from many different sectors over several years and it therefore seems important to leverage this experience to address the threat of HEMP and IEMI.

### **A.4 HPEM resilience framework implementation**

#### **A.4.1 Overview**

The key elements of each function as it pertains to HPEM are described below. The protect function in particular has design features which are specifically unique to the HEMP and IEMI problem, whereas the other functions have many similar characteristics to the existing cyber security framework. Therefore, the design choices and recommendations for the protect function are more detailed and technical than for the other functions.

#### **A.4.2 Identify**

##### **A.4.2.1 General**

The identify function, category and sub-categories are shown in Table A.3. Note that the items are numbered in accordance with the table presented in [11] to enable traceability to the originating document.

**Table A.3 – Identify function of the HPEM resilience framework**

Function	Category	Sub-category
<b>IDENTIFY (ID)</b>	Asset management (ID.AM): The data, personnel, devices, systems, and facilities that enable the organization to achieve business purposes are identified and managed in accordance with their relative importance to organizational objectives and the organization's risk strategy.	ID.AM-3-HPEM: Organizational communication and data flows are mapped paying specific attention to those which can be vulnerable to HPEM and those that will be necessary for effective restoration
		ID.AM-6-HPEM: HPEM resilience roles and responsibilities for the entire workforce and third-party stakeholders (e.g., suppliers, customers, partners) are established
	Business environment (ID.BE): The organization's mission, objectives, stakeholders, and activities are understood and prioritized; this information is used to inform HPEM resilience roles, responsibilities, and risk management decisions.	ID.BE-4-HPEM: Dependencies and critical functions for delivery of critical services which could be disrupted by HPEM are established
	Governance (ID.GV): The policies, procedures, and processes to manage and monitor the organization's regulatory, legal, risk, environmental, and operational requirements are understood and inform the management of HPEM risk.	ID.GV-1-HPEM: Organizational HPEM resilience policy is established and communicated
		ID.GV-2-HPEM: HPEM resilience roles and responsibilities are coordinated and aligned with internal roles and external partners
		ID.GV-4-HPEM: Governance and risk management processes address HPEM risks
	Risk assessment (ID.RA): The organization understands the HPEM risk to organizational operations (including mission, functions, image, or reputation), organizational assets, and individuals.	ID.RA-1-HPEM: Asset vulnerabilities to HPEM are identified and documented and an awareness of HPEM susceptibilities is maintained
		ID.RA-2-HPEM: HPEM threat intelligence is received from the authority and information sharing forums
		ID.RA-3-HPEM: HPEM threats, both internal and external, are identified and documented
		ID.RA-4-HPEM: Potential business impacts of HPEM events are identified
		ID.RA-5-HPEM: Threats, vulnerabilities, likelihoods, and impacts are used to determine risk from HPEM disturbances
		ID.RA-6-HPEM: Risk responses to HPEM disturbances are identified and prioritized
	Supply chain risk management (ID.SC): The organization's priorities, constraints, risk tolerances, and assumptions are established and used to support risk decisions associated with managing supply chain risk. The organization has established and implemented processes to identify, assess and manage supply chain risks.	ID.SC-1-HPEM: Supply chain risk management processes are identified, established, assessed, managed, and agreed by organizational stakeholders, recognising the unique risks to the supply chain from HPEM disturbances
		ID.SC-5-HPEM: Response and recovery planning and testing are conducted with suppliers and third-party providers, recognising the unique risks to the supply chain from HPEM environments

**A.4.2.2 Discussion**

The primary purpose of the identify function is to promote an organizational understanding to managing risks to systems, people, assets, data, and capabilities. Many critical infrastructures and many businesses are well used to owning and managing business continuity, response and recovery or contingency strategies and plans. However, at the organizational leadership level the ramifications of HPEM disturbances can be misunderstood by senior leadership. The sub-categories in this function serve to promote leadership of HPEM resilience.

Two key aspects here are risks assessment and supply chain management. The risk assessment sub-categories for HPEM will require the organization to stay informed of the risk of HPEM disturbance and this could be informed by simply maintaining a watching brief or survey of HPEM threats, through monitoring the geo-political situation and any escalation, through carrying out susceptibility or immunity testing of functionally critical equipment to HPEM disturbances. IEC 61000-4-36 provides guidance on how susceptibility testing can be achieved.

The supply chain category is particularly important for HEMP disturbances since due to the very wide geographical coverage of the HEMP E1 disturbance, interdependencies in the supply chain will be simultaneously exposed to risk of disruption. For instance, an energy network operator can be highly reliant on telecommunications and transport infrastructure yet have no control and no knowledge of the resilience of those critical sectors. Some form of fall-back or reversionary mode can be required, for example, in the case above an alternative means of communicating will need to be provided. This back-up communication system could be implemented, for example, by a mobile 'drop-in' emergency information communications technology (ICT) node which is either stored in a disconnected and unpowered state when an HPEM disturbance is threatened, or which in itself has sufficient HPEM protection to work-through.

Overall, the objective of this function is to institutionalise an awareness of the potential susceptibilities and consequences of HPEM disturbances at all levels of an organization and particularly at the leadership level.

#### **A.4.3 Protect**

##### **A.4.3.1 General**

The protect function, category and sub-categories are shown in Table A.4. Note that the items are numbered in accordance with the table presented in [11] to enable traceability to the originating document.

IECNORM.COM : Click to view the full PDF of IEC 61000-5-6:2024

**Table A.4 – Protect function of the HPEM resilience framework**

Function	Category	Sub-category
<b>PROTECT (PR)</b>	HPEM protection (PR.AC): Electronics assets and associated facilities are protected and managed in accordance with the assessed risk.	PR.AC-1-HPEM: Electronic assets (including control systems, ICT, safety, security and environmental controls) identified as at risk from HPEM are protected at a level appropriate to their criticality with respect to their function and importance to response and recovery
		PR.AC-2-HPEM: Physical access to assets is managed and protected, recognising the unique risks to electronic access technologies from HPEM disturbance
	Awareness and training (PR.AT): The organization's personnel and partners are provided with EMP and IEMI awareness education and are trained to perform their EMP and IEMI-related duties and responsibilities in accordance with related policies, procedures, and agreements.	PR.AT-5-HPEM: Physical and cybersecurity personnel understand their roles and responsibilities with regard to the specific threat from HPEM environments.
	Data security (PR.DS): Information and records (data) are managed in accordance with the organization's risk strategy to protect the confidentiality, integrity, and availability of information.	PR.DS-1-HPEM: Data-at-rest is protected from HPEM disturbance
		PR.DS-2-HPEM: Data-in-transit and communications are protected from HPEM
	Information protection processes and procedures (PR.IP): Security policies (that address purpose, scope, roles, responsibilities, management commitment, and coordination among organizational entities), processes, and procedures are maintained and used to manage protection of information systems and assets.	PR.IP-9-HPEM: Response plans (incident response and business continuity) and recovery plans (incident recovery and disaster recovery) for the specific threats of HPEM are in place and managed
		PR.IP-10-HPEM: Response and recovery plans are tested with regard to the specific threat from HPEM
		PR.IP-12-HPEM: A vulnerability management plan is developed and implemented with recognition of the unique characteristics of HPEM
Maintenance (PR.MA): Maintenance and repairs of industrial control and information system components are performed in accordance with policies and procedures.	PR.MA-1-HPEM: Maintenance and repair of organizational assets and any specific HPEM protection systems, are performed and logged, with approved and controlled tools	
Protective technology (PR.PT): Technical security solutions are managed to ensure the security and resilience of systems and assets, in accordance with related policies, procedures, and agreements.	PR.PT-4-HPEM: Communications and control networks vital to function, response and recovery are protected from HPEM	

**A.4.3.2 Discussion**

**A.4.3.2.1 General**

Several sub-categories in the protect function encourage a more holistic view of protection with consideration of other threats such as cyber and physical threats. For instance PR.AC-2-HPEM recommends consideration of the unique risks to electronic access technologies from HPEM disturbance. In many sectors use of electronic access technologies such as electronic biometric scanners and swipe cards is encouraged but these devices can have a vulnerability to HPEM disturbance. Sub-categories PR.DS-1-HPEM and PR.DS-2-HPEM serve as a reminder that many modern critical facilities are highly networked and that critical decisions are made on the basis of live or stored data. Protection of the data in-transit and at rest can be of higher critical importance than protection of a critical facility node.

Sub-categories PR.IP-9-HPEM, PR.IP-10-HPEM and PR.IP-12-HPEM are included to recommend that protection of the recovery 'agent' be considered. For example, a recovery agent can be a field service engineer or first responder. The first responder shall be notified of a disturbance, directed to a facility, travel to a facility and carry out recovery processes whilst in communication with a control centre. The ability of a first responder to carry out their duties when their own systems are compromised by HPEM disturbance should be considered.

Finally, sub-category PR.MA-1-HPEM serves as a reminder that maintenance of any installed protection through-life is vitally important. Unfortunately, there are many examples where installed HPEM protection has been severely degraded through neglect or misuse.

#### **A.4.3.2.2 Protection technologies relevant to a resilience approach**

##### **A.4.3.2.2.1 General**

All of the protection techniques and approaches described in the main body of this document are relevant to the protect function of the resilience framework. PR.AC-1-HPEM in Table A.4 recommends that systems be "protected at a level appropriate to their criticality with respect to their function and importance to response and recovery". IEC TS 61000-5-10, IEC TR 61000-5-3 and IEC 61000-5-5 in particular can be used to tailor the protection level required based on the acceptance of risk and the criticality of the system.

Many critical facilities will have a response and recovery plan that can be appropriate with adaptation for HPEM disturbances. Temporary disruption of critical electronic systems can in many cases be accommodated. On the whole, temporary disruption of function, due to other environmental factors, for example severe weather, fire or human error is a fairly common occurrence. However, due to the very wide geographic area coverage of the HEMP E1 disturbance in particular, a zero-protection, recovery-only model is not to be advised. Unprotected electronic systems have systematically been shown to be vulnerable to damage from HEMP E1. Recovering damaged systems over a large geographic area, which might be anticipated for a HEMP disturbance, is likely to exhaust any remaining reserves and prolong outage times. A minimum viable protection should therefore aim to prevent damage to systems.

##### **A.4.3.2.2.2 Shielded cables**

Shielded cables are not discussed at length in the main body of this document but high quality shielded cables with multiple cores are now more commonly available. The shielding performance of the cable shall be qualified against the protection requirement. A shielded cable performance is only as good as the cable termination or connector. The termination or connector shall provide a high quality, low impedance 360° circumferential bond to the terminating structure or shield boundary.

##### **A.4.3.2.2.3 Shielded cable layout**

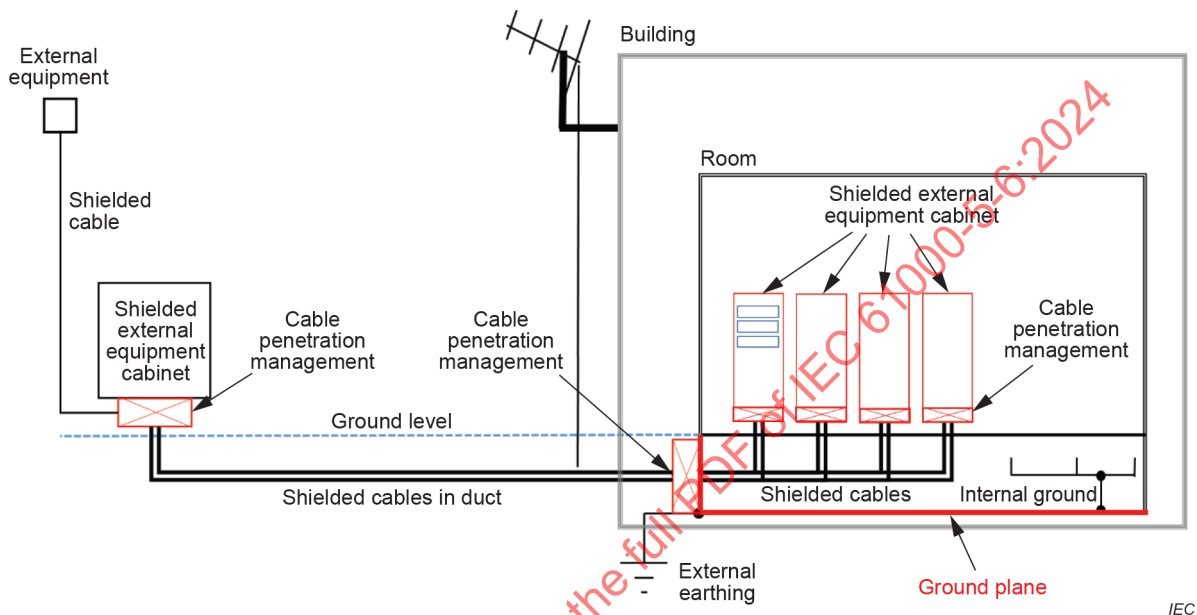
The performance (reduction in core coupling) of shielded cables, indeed of all cables, can be improved by laying cables so that they are in contact with either the ground or a ground plane. This configuration using shielded cables and ground plane is shown in Figure A.4. In some instances, cables can be buried in the ground or laid within a trench, duct or culvert. This layout technique, in addition to keeping cable runs shorter than 10 m long, can provide a significant reduction in core coupling of HEMP E1. This is explained in IEC TS 61000-5-10 and IEC 61000-2-10.

Cable installations longer than 10 m can also be laid out with changes in the linear direction, for example 90° turns at up to 10 m intervals to break long runs into smaller length sections.

**A.4.3.2.2.4 Shielded cabinets**

Shielded cabinets are described in 6.4.4. In the context of the resilience approach shielded cabinets can be considered to provide a very effective solution. In the context of resilience, a shield violation or defect of a shielded room can place all equipment within the room at risk, whereas a violation or defect of a shielded cabinet only places the equipment within the cabinet at risk.

This configuration using shielded cabinets is shown in Figure A.4.



**Figure A.4 – Protection scheme utilising shielded cables and shielded cabinets**

**A.4.3.2.2.5 Combination filters**

A combination filter combines filter technology with an SPD within a single unit. This is technology that has emerged since the main body of this document was prepared. There are some advantages in this combination approach since the installation of the interconnections between the SPD element and the filter element can be managed to maximise protection performance. The testing of combination filters to HEMP environments is described in IEC 61000-4-25.

**A.4.3.2.2.6 HPEM protection and resilience of ancillary systems**

Ancillary systems can be important to provide resilience. Examples of ancillary systems include but are not limited to:

- building management systems such as heating ventilation and air conditioning (HVAC) controls;
- AC/DC equipment cabinets;
- standby generator;
- security systems and in particular electronic access systems; and
- emergency or safety systems such as fire detection and alarms.

Some of these systems were described in the main body of this document in Clause 8. A dedicated shielding protection solution for ancillary systems can be unnecessary, instead consideration should be given to fault conditions using, for example, fault tree analysis.

For HVAC, for example, failure of the controller can mean that vital cooling is not provided to the equipment. However, it is likely that first responders can be on site within a few hours of an HPEM disturbance. It is therefore unlikely that the environmental conditions, for example high ambient temperatures, will cause a significant risk of disruption before function of the HVAC can be restored or other mitigation measures can be introduced, for example portable HVAC.

For security systems the primary concern is that electronic access controls can fail in a manner that prevents entry or egress from a building or the site. As above, a manual override should be provided. A secondary concern is that noise from security alarms impedes the first responder's ability to receive communications. Again, a manual override to any electronic system is suggested as a pragmatic mitigation measure.

For emergency or safety systems an automated fire suppression system should be avoided since fire alarms can be triggered by an HPEM disturbance. Noise from fire alarms and sounders can impede the first responder's ability to receive communications. A manual override or kill switch should therefore be provided.

In summary the general design rules for HPEM protection of ancillary equipment should be such that:

- 1) all electrical, data and control cables including those to and from ancillary equipment should be run on the ground, ideally on a ground plane;
- 2) back-up devices (such as motor generators) should be electrically isolated (live and neutral) at the generator when not in use. If cables cross the ground plane boundary then cable lengths should be kept to a length of less than 10 m long. Isolation points can be used to extend the distance at 10 m intervals;
- 3) any conducting parts should be less than 5 m long or if they exceed that limit, should include a dielectric break (for example motor standby generator exhaust pipe);
- 4) as far as possible ancillary and backup equipment (motor generators) should be purely electro-mechanical. If such equipment does have electronics then the electronic components should be protected;
- 5) a manual means of starting, stopping and monitoring ancillary equipment shall be provided.

#### **A.4.3.2.3 HPEM protection to enable or facilitate response and recovery**

Consideration has been given to mitigating the effect of HPEM disturbances on response and recovery. Two examples of areas for consideration are identified as follows:

- home/office working for first responders or critical staff, or both;
- transportation of first responders to substation sites.

First responders and other staff who are 'on watch' during an HPEM disturbance could be working from their home office. There is a risk that ICT equipment such as laptop, router, mobile phone and handheld radio are relied upon to enable prompt response and direct recovery. This equipment can be vulnerable to disruption and damage from an E1 HEMP disturbance if it is plugged in to the mains for charging, for example. This ICT equipment will be less susceptible if it is unpowered and removed from the mains supply but this is likely to be impractical. A pragmatic suggestion to mitigate this risk for first responders and workers who could be called on to respond and recover a system from a HPEM disturbance can be to use battery powered ICT (e.g. laptop computer) with mains power strips that include SPDs.

Many countries are transitioning to electric vehicles or electric-hybrid vehicles to support green initiatives. Modern petrol and diesel vehicles are quite resistant to E1 HEMP and if the vehicles are not running they are unlikely to be affected by E1 HEMP. The vulnerability of electric vehicles to HPEM is not known, however it can be expected that an electric vehicle that is not running is unlikely to be affected by E1 HEMP. However, there is a risk that E1 HEMP transients can couple in to the vehicle via the charging cable whilst the vehicle is on charge. A review of the surge suppression arrangements for e-vehicle charging systems and cables should be carried out and an appropriate surge suppression device provided if deemed necessary.

**A.4.4 Detect**

**A.4.4.1 General**

The detect function, category and sub-categories are shown in Table A.5. Note that the items are numbered in accordance with the table presented in in [11] to enable traceability to the originating document.

**Table A.5 – Detect function of the HPEM resilience framework**

Function	Category	Sub-Category
DETECT (DE)	Anomalies and events (DE.AE): Anomalous activity is detected and the potential impact of events is understood.	DE.AE-2-HPEM: Detected HPEM events are analysed to understand attack methods
		DE.AE-3-HPEM: HPEM event data are collected and correlated from multiple sources and sensors
		DE.AE-4-HPEM: The impact of HPEM events is determined
		DE.AE-5-HPEM: HPEM incident alert thresholds are established
	Security continuous monitoring (DE.CM): Electronic assets are monitored to identify EMP and IEMI events and verify the effectiveness of protective measures.	DE.CM-1-HPEM: Critical electronic systems are monitored to detect potential HPEM events
		DE.CM-2-HPEM: The physical environment is monitored for potential correlation of HPEM events and any HPEM protection is monitored to ensure it is continuously providing adequate levels of protection
		DE.CM-8-HPEM: Monitoring of protective elements such as shielding performance is performed
	Detection processes (DE.DP): Detection processes and procedures are maintained and tested to ensure awareness of anomalous events.	DE.DP-1-HPEM: Roles and responsibilities for detection are well defined to ensure accountability
		DE.DP-2-HPEM: Detection activities comply with all applicable requirements
		DE.DP-3-HPEM: Detection processes are tested
		DE.DP-4-HPEM: HPEM event detection information is communicated
		DE.DP-5-HPEM: HPEM detection processes are continuously improved

**A.4.4.2 Discussion**

**A.4.4.2.1 General**

Having the capability to detect anomalous activity and to understand the potential impact of disruptions is vital in order to mitigate the risk of HPEM events. Detection of HPEM also informs the whole resilience process.

It is not possible in most cases for human senses to detect HPEM and a HPEM disturbance is unlikely to leave any discernible tell-tale sign or witness [12]. Detection technologies are therefore required to provide confirmation that a disturbance to a system function is the result of an HPEM environment.