

# TECHNICAL REPORT



**Performance of high-voltage direct current (HVDC) systems with  
line-commutated converters –  
Part 1: Steady-state conditions**

IECNORM.COM : Click to view the full PDF of IEC TR 60919-1:2020 RLV



## THIS PUBLICATION IS COPYRIGHT PROTECTED

Copyright © 2020 IEC, Geneva, Switzerland

All rights reserved. Unless otherwise specified, no part of this publication may be reproduced or utilized in any form or by any means, electronic or mechanical, including photocopying and microfilm, without permission in writing from either IEC or IEC's member National Committee in the country of the requester. If you have any questions about IEC copyright or have an enquiry about obtaining additional rights to this publication, please contact the address below or your local IEC member National Committee for further information.

IEC Central Office  
3, rue de Varembe  
CH-1211 Geneva 20  
Switzerland

Tel.: +41 22 919 02 11  
[info@iec.ch](mailto:info@iec.ch)  
[www.iec.ch](http://www.iec.ch)

### About the IEC

The International Electrotechnical Commission (IEC) is the leading global organization that prepares and publishes International Standards for all electrical, electronic and related technologies.

### About IEC publications

The technical content of IEC publications is kept under constant review by the IEC. Please make sure that you have the latest edition, a corrigendum or an amendment might have been published.

#### IEC publications search - [webstore.iec.ch/advsearchform](http://webstore.iec.ch/advsearchform)

The advanced search enables to find IEC publications by a variety of criteria (reference number, text, technical committee,...). It also gives information on projects, replaced and withdrawn publications.

#### IEC Just Published - [webstore.iec.ch/justpublished](http://webstore.iec.ch/justpublished)

Stay up to date on all new IEC publications. Just Published details all new publications released. Available online and once a month by email.

#### IEC Customer Service Centre - [webstore.iec.ch/csc](http://webstore.iec.ch/csc)

If you wish to give us your feedback on this publication or need further assistance, please contact the Customer Service Centre: [sales@iec.ch](mailto:sales@iec.ch).

#### Electropedia - [www.electropedia.org](http://www.electropedia.org)

The world's leading online dictionary on electrotechnology, containing more than 22 000 terminological entries in English and French, with equivalent terms in 16 additional languages. Also known as the International Electrotechnical Vocabulary (IEV) online.

#### IEC Glossary - [std.iec.ch/glossary](http://std.iec.ch/glossary)

67 000 electrotechnical terminology entries in English and French extracted from the Terms and Definitions clause of IEC publications issued since 2002. Some entries have been collected from earlier publications of IEC TC 37, 77, 86 and CISPR.

IECNORM.COM : Click to view the full text of IEC 60079-1:2020 RLV

# TECHNICAL REPORT



---

**Performance of high-voltage direct current (HVDC) systems with  
line-commutated converters –  
Part 1: Steady-state conditions**

INTERNATIONAL  
ELECTROTECHNICAL  
COMMISSION

---

ICS 29.200; 29.240.99

ISBN 978-2-8322-8226-7

**Warning! Make sure that you obtained this publication from an authorized distributor.**

## CONTENTS

FOREWORD.....	8
INTRODUCTION.....	2
1 Scope.....	11
2 Normative references .....	12
3 Terms and definitions .....	12
4 Types of HVDC systems .....	12
4.1 General.....	12
4.2 HVDC back-to-back system .....	13
4.3 Monopolar HVDC system with earth return HVDC system.....	13
4.4 Monopolar HVDC system with metallic return HVDC system.....	17
4.5 Bipolar earth return HVDC system .....	18
4.6 Bipolar HVDC system with metallic return HVDC system.....	21
4.7 Two 12-pulse groups per pole.....	22
4.8 Converter transformer arrangements.....	25
4.9 DC switching considerations .....	26
4.10 Series-capacitor-compensated HVDC systems.....	29
4.11 LCC/VSC hybrid bipolar system .....	33
5 Environment information.....	34
6 Rated power, current and voltage .....	37
6.1 Rated power .....	37
6.1.1 General .....	37
6.1.2 Rated power of an HVDC system with transmission line .....	37
6.1.3 Rated power of an HVDC back-to-back system.....	37
6.1.4 Direction of power flow.....	37
6.2 Rated current.....	37
6.3 Rated voltage .....	38
7 Overload and equipment capability.....	38
7.1 Overload.....	38
7.2 Equipment capability.....	39
7.2.1 General .....	39
7.2.2 Converter valve capability.....	39
7.2.3 Capability of oil-cooled transformers and reactors .....	39
7.2.4 AC harmonic filter and reactive power compensation equipment capability .....	40
7.2.5 Switchgear and buswork capability .....	40
8 Minimum power transfer and no-load stand-by state .....	40
8.1 General.....	40
8.2 Minimum current.....	40
8.3 Reduced direct voltage operation.....	40
8.4 No-load stand-by state.....	41
8.4.1 General .....	41
8.4.2 Converter transformers – No-load stand-by .....	41
8.4.3 Converter valves – No-load stand-by .....	41
8.4.4 AC filters and reactive compensation – No-load stand-by .....	41
8.4.5 DC reactors and DC filters – No-load stand-by .....	42

8.4.6	Auxiliary power system – No-load stand-by	42
8.4.7	Control and protection – No-load stand-by	42
9	AC system	42
9.1	General	42
9.2	AC voltage	42
9.2.1	Rated AC voltage	42
9.2.2	Steady-state voltage range	42
9.2.3	Negative sequence voltage	43
9.3	Frequency	43
9.3.1	Rated frequency	43
9.3.2	Steady-state frequency range	43
9.3.3	Short-term frequency variation	43
9.3.4	Frequency variation during emergency	44
9.4	System impedance at fundamental frequency	44
9.5	System impedance at harmonic frequencies	44
9.6	Positive and zero-sequence surge impedance	44
9.7	Other sources of harmonics	44
9.8	Subsynchronous torsional interaction (SSTI)	44
10	Reactive power	45
10.1	General	45
10.2	Conventional HVDC systems	45
10.3	Series capacitor compensated HVDC schemes	47
10.4	Converter reactive power consumption	47
10.5	Reactive power balance with the AC system	47
10.6	Reactive power supply	47
10.7	Maximum size of switchable VAR banks	48
11	HVDC transmission line, earth electrode line and earth electrode	48
11.1	General	48
11.2	Overhead line(s)	48
11.2.1	General	48
11.2.2	Electrical parameters	48
11.3	Cable line(s)	49
11.3.1	General	49
11.3.2	Electrical parameters	49
11.4	Earth electrode line	50
11.5	Earth electrode	50
12	Reliability	50
12.1	General	50
12.2	Outage	50
12.2.1	General	50
12.2.2	Scheduled outage	50
12.2.3	Forced outage	50
12.3	Capacity	51
12.3.1	General	51
12.3.2	Maximum continuous capacity $P_m$	51
12.3.3	Outage capacity $P_o$	51
12.3.4	Outage derating factor (ODF)	51
12.4	Outage duration terms	51

12.4.1	Actual outage duration (AOD).....	51
12.4.2	Equivalent outage duration (EOD).....	51
12.4.3	Period hours (PH).....	51
12.4.4	Actual outage hours (AOH).....	52
12.4.5	Equivalent outage hours (EOH).....	52
12.5	Energy unavailability (EU).....	52
12.5.1	General.....	52
12.5.2	Forced energy unavailability (FEU).....	53
12.5.3	Scheduled energy unavailability (SEU).....	53
12.6	Energy availability (EA).....	53
12.7	Maximum permitted number of forced outages.....	53
12.8	Statistical probability of outages.....	53
12.8.1	Component faults.....	53
12.8.2	External faults.....	53
13	HVDC control.....	54
13.1	Control objectives.....	54
13.2	Control structure.....	54
13.2.1	General.....	54
13.2.2	Converter unit firing control.....	54
13.2.3	Pole control.....	55
13.2.4	HVDC substation control.....	58
13.2.5	Master control.....	60
13.3	Control order settings.....	60
13.4	Current limits.....	60
13.5	Control circuit redundancy.....	61
13.6	Protection system.....	61
13.7	Measurements.....	61
14	Telecommunication.....	62
14.1	Types of telecommunication links.....	62
14.2	Telephone.....	62
14.3	Power line carrier (PLC).....	62
14.4	Microwave.....	63
14.5	Radio link.....	63
14.6	Optical fibre telecommunication.....	63
14.7	Classification of data to be transmitted.....	63
14.8	Fast response telecommunication.....	64
14.9	Reliability.....	64
15	Auxiliary power supplies.....	65
15.1	General.....	65
15.2	Reliability and load classification.....	65
15.3	AC auxiliary supplies.....	66
15.4	Batteries and uninterruptible power supplies (UPS).....	66
15.5	Emergency supply.....	67
16	Audible noise.....	67
16.1	General.....	67
16.2	Public nuisance.....	67
16.2.1	General.....	67
16.2.2	Valves and valve coolers.....	68

16.2.3	Converter transformers .....	68
16.2.4	DC reactors .....	68
16.2.5	AC filter reactors .....	68
16.3	Noise in working areas .....	68
17	Harmonic interference – AC .....	69
17.1	AC side harmonic generation .....	69
17.2	Filters .....	69
17.3	Interference disturbance criteria .....	72
17.4	Levels for interference .....	73
17.5	Filter performance .....	74
18	Harmonic interference – DC .....	74
18.1	DC side interference .....	74
18.1.1	Harmonic currents in HVDC transmission line .....	74
18.1.2	Characteristic and non-characteristic harmonics .....	74
18.1.3	Groups of harmonics .....	75
18.1.4	Calculation of harmonic currents .....	75
18.1.5	Calculation of induced voltages .....	75
18.1.6	Personnel safety .....	75
18.1.7	DC filters .....	75
18.2	DC filter performance .....	76
18.2.1	Requirements for voice communication circuits .....	76
18.2.2	Levels of interference .....	76
18.2.3	Safety .....	76
18.3	Specification requirements .....	77
18.3.1	Economic level of filtering .....	77
18.3.2	General criteria .....	78
18.3.3	Factors to be taken into account for calculations .....	78
18.3.4	Calculation of currents .....	79
19	Power line carrier interference (PLC) .....	80
19.1	General .....	80
19.2	Performance specification .....	81
20	Radio frequency interference .....	82
20.1	General .....	84
20.2	RFI from HVDC systems .....	84
20.2.1	RFI sources .....	84
20.2.2	RFI propagation .....	85
20.2.3	RFI characteristics .....	85
20.3	RFI performance specification .....	86
20.3.1	RFI risk assessment .....	86
20.3.2	Specification RFI limit and its verification .....	86
20.3.3	Design aspects .....	87
21	Power losses .....	82
21.1	General .....	87
21.2	Main contributing sources .....	88
21.2.1	General .....	88
21.2.2	AC filters and reactive power compensation .....	88
21.2.3	Converter bridges .....	88
21.2.4	Converter transformer .....	88

21.2.5	DC reactor .....	88
21.2.6	DC filter .....	88
21.2.7	Auxiliary equipment .....	89
21.2.8	Other components .....	89
22	Provision for extensions to the HVDC systems .....	89
22.1	General.....	89
22.2	Specification for extensions .....	89
Annex A (informative) Factors affecting reliability and availability of converter stations .....		92
A.1	Design and documentation.....	92
A.1.1	General .....	92
A.1.2	General design principles .....	92
A.1.3	More detailed design principles .....	93
A.1.4	Software design principles.....	93
A.1.5	RAM records.....	94
A.2	Operation.....	94
A.2.1	Training .....	94
A.2.2	Maintenance programs affecting reliability .....	95
A.2.3	Spare parts.....	96
Bibliography.....		99
Figure 1 – Twelve-pulse converter unit .....		11
Figure 2 – Examples of back-to-back HVDC systems.....		14
Figure 3 – Monopolar HVDC system with earth return .....		15
Figure 4 – Two 12-pulse units in series.....		16
Figure 5 – Two 12-pulse units in parallel.....		17
Figure 6 – Monopolar HVDC system with metallic return system.....		18
Figure 7 – Bipolar system .....		19
Figure 8 – Metallic return operation of the unfaulted pole in a bipolar system.....		20
Figure 9 – Bipolar metallic return HVDC system with metallic return .....		22
Figure 10 – Bipolar system with two 12-pulse units in series per pole .....		24
Figure 11 – Bipolar system with two 12-pulse units in parallel per pole .....		25
Figure 12 – DC switching of line conductors .....		27
Figure 13 – DC switching of converter poles .....		28
Figure 14 – DC switching – Overhead line to cable .....		29
Figure 15 – DC switching – Two bipolar converters and lines.....		30
Figure 16 – DC switching – Intermediate.....		31
Figure 17 – Capacitor commutated converter configurations .....		32
Figure 18 – LCC/VSC hybrid bipolar system .....		34
Figure 19 – Variations of reactive power $Q$ with active power $P$ of an HVDC converter.....		46
Figure 20 – Control hierarchy for HVDC/UHVDC system.....		57
Figure 21 – Converter voltage-current characteristic .....		59
Figure 22 – Examples of AC filter connections for a bipole HVDC system .....		70
Figure 23 – Circuit diagrams for different filter types.....		71
Figure 24 – RY COM noise interference meter results averaged – Typical plot of converter noise interference levels on the DC line corrected and normalized to 3 kHz bandwidth – 0 dBm = 0,775 V .....		82

Figure 25 – Recommended measurement procedure with definition of measuring point ..... 87

Figure 26 – Extension methods for HVDC systems ..... 91

Table 1 – Information supplied for HVDC substation ..... 35

Table 2 – Performance parameters for voice communication circuits: Subscribers and trunk circuits ..... 77

IECNORM.COM : Click to view the full PDF of IEC TR 60919-1:2020 RLV

## INTERNATIONAL ELECTROTECHNICAL COMMISSION

**PERFORMANCE OF HIGH-VOLTAGE DIRECT CURRENT  
(HVDC) SYSTEMS WITH LINE-COMMUTATED CONVERTERS –****Part 1: Steady-state conditions**

## FOREWORD

- 1) The International Electrotechnical Commission (IEC) is a worldwide organization for standardization comprising all national electrotechnical committees (IEC National Committees). The object of IEC is to promote international co-operation on all questions concerning standardization in the electrical and electronic fields. To this end and in addition to other activities, IEC publishes International Standards, Technical Specifications, Technical Reports, Publicly Available Specifications (PAS) and Guides (hereafter referred to as "IEC Publication(s)"). Their preparation is entrusted to technical committees; any IEC National Committee interested in the subject dealt with may participate in this preparatory work. International, governmental and non-governmental organizations liaising with the IEC also participate in this preparation. IEC collaborates closely with the International Organization for Standardization (ISO) in accordance with conditions determined by agreement between the two organizations.
- 2) The formal decisions or agreements of IEC on technical matters express, as nearly as possible, an international consensus of opinion on the relevant subjects since each technical committee has representation from all interested IEC National Committees.
- 3) IEC Publications have the form of recommendations for international use and are accepted by IEC National Committees in that sense. While all reasonable efforts are made to ensure that the technical content of IEC Publications is accurate, IEC cannot be held responsible for the way in which they are used or for any misinterpretation by any end user.
- 4) In order to promote international uniformity, IEC National Committees undertake to apply IEC Publications transparently to the maximum extent possible in their national and regional publications. Any divergence between any IEC Publication and the corresponding national or regional publication shall be clearly indicated in the latter.
- 5) IEC itself does not provide any attestation of conformity. Independent certification bodies provide conformity assessment services and, in some areas, access to IEC marks of conformity. IEC is not responsible for any services carried out by independent certification bodies.
- 6) All users should ensure that they have the latest edition of this publication.
- 7) No liability shall attach to IEC or its directors, employees, servants or agents including individual experts and members of its technical committees and IEC National Committees for any personal injury, property damage or other damage of any nature whatsoever, whether direct or indirect, or for costs (including legal fees) and expenses arising out of the publication, use of, or reliance upon, this IEC Publication or any other IEC Publications.
- 8) Attention is drawn to the Normative references cited in this publication. Use of the referenced publications is indispensable for the correct application of this publication.
- 9) Attention is drawn to the possibility that some of the elements of this IEC Publication may be the subject of patent rights. IEC shall not be held responsible for identifying any or all such patent rights.

**This redline version of the official IEC Standard allows the user to identify the changes made to the previous edition. A vertical bar appears in the margin wherever a change has been made. Additions are in green text, deletions are in strikethrough red text.**

The main task of IEC technical committees is to prepare International Standards. However, a technical committee may propose the publication of a technical report when it has collected data of a different kind from that which is normally published as an International Standard, for example "state of the art".

IEC TR 60919-1, which is a technical report, has been prepared by subcommittee 22F: Power electronics for electrical transmission and distribution systems, of IEC technical committee 22: Power electronic systems and equipment.

This fourth edition cancels and replaces the third edition, published in 2010, Amendment 1:2013 and Amendment 2:2017. This edition constitutes a technical revision.

This edition includes the following significant technical changes with respect to the previous edition:

- a) Figure 8 and Figure 20 have been updated, a new Figure 18 "LCC/VSC hybrid bipolar system" has been added;
- b) the HVDC system control objectives have been supplemented;
- c) additional explanations regarding the HVDC system control structure have been given;
- d) a new subclause 13.6 on HVDC system protection has been added.

The text of this Technical Report is based on the following documents:

Draft TR	Report on voting
22F/535/DTR	22F/549A/RVDTR

Full information on the voting for the approval of this Technical Report can be found in the report on voting indicated in the above table.

This document has been drafted in accordance with the ISO/IEC Directives, Part 2.

A list of all parts of the IEC 60919 series, published under the general title *Performance of high-voltage direct current (HVDC) systems with line-commutated converters*, can be found on the IEC website.

The committee has decided that the contents of this document will remain unchanged until the stability date indicated on the IEC website under "<http://webstore.iec.ch>" in the data related to the specific document. At this date, the document will be

- reconfirmed,
- withdrawn,
- replaced by a revised edition, or
- amended.

**IMPORTANT – The 'colour inside' logo on the cover page of this publication indicates that it contains colours which are considered to be useful for the correct understanding of its contents. Users should therefore print this document using a colour printer.**

## INTRODUCTION

The difference between system performance specifications and equipment design specifications for individual components of a system is realized. Frequently, performance specifications are prepared as a single package for the two HVDC substations in a particular system. Alternatively, some parts of the HVDC system can be separately specified and purchased. In such cases, due consideration ~~should be~~ is given to coordination of each part with the overall HVDC system performance objectives and to ensuring that the interface of each with the system ~~should be~~ is clearly defined. Typical of such parts, listed in the appropriate order of relative ease for separate treatment and interface definition, are:

- a) DC line, electrode line and earth electrode;
- b) telecommunication system;
- c) converter building, foundations and other civil engineering work;
- d) reactive power supply including AC shunt capacitor banks, shunt reactors, synchronous and static reactive power (var) compensators;
- e) AC switchgear;
- f) DC switchgear;
- g) auxiliary systems;
- h) AC filters;
- i) DC filters;
- j) DC reactors;
- k) converter transformers;
- l) surge arresters;
- m) series commutation capacitors;
- n) valves and their ancillaries;
- o) control and protection systems.

NOTE The last four items are the most difficult to separate, and, in fact, separation of these four ~~may~~ can be inadvisable.

Clause 4 to Clause 22 of this document set out a complete steady-state performance specification for an HVDC system ~~should consider Clauses 3 to 21 of this report.~~

~~Terms and definitions for high voltage direct current (HVDC) transmission used in this report are given in IEC 60633.~~

Since the equipment items are usually separately specified and purchased, the HVDC transmission line, earth electrode line and earth electrode (see Clause 11) are included only because of their influence on the HVDC system performance.

For the purpose of this document, an HVDC substation is assumed to consist of one or more converter units installed in a single location together with buildings, reactors, filters, reactive power supply, control, monitoring, protective, measuring and auxiliary equipment. While there is no discussion of AC switching substations in this document, AC filters and reactive power sources are included, although they ~~may~~ can be connected to an AC bus separate from the HVDC substation, as discussed in Clause 17.

# PERFORMANCE OF HIGH-VOLTAGE DIRECT CURRENT (HVDC) SYSTEMS WITH LINE-COMMUTATED CONVERTERS –

## Part 1: Steady-state conditions

### 1 Scope

This part of IEC 60919 provides general guidance on the steady-state performance requirements of high-voltage direct current (HVDC) systems. It concerns the steady-state performance of two-terminal HVDC systems utilizing 12-pulse converter units comprised of three-phase bridge (double-way) connections (see Figure 1), but it does not cover multi-terminal HVDC transmission systems. Both terminals are assumed to use thyristor valves as the main semiconductor valves and to have power flow capability in both directions. Diode valves are not considered in this document.

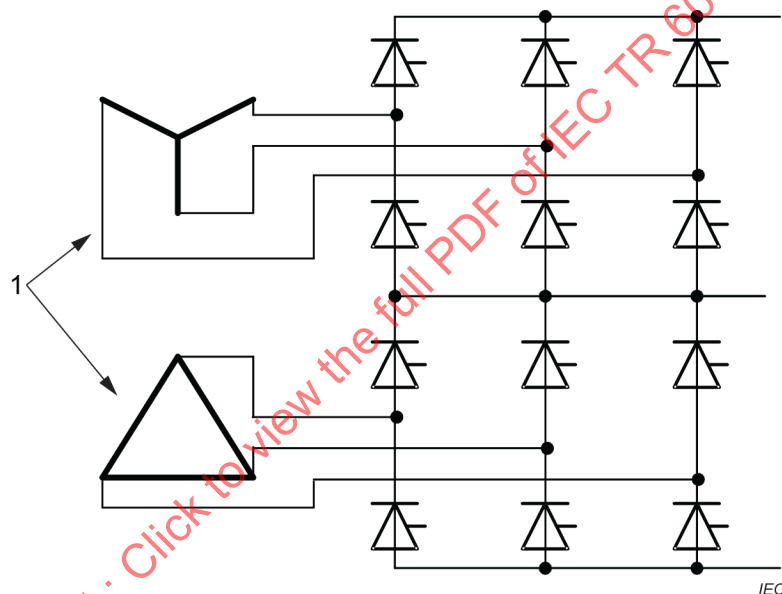

#### Key

1 Transformer valve windings

**Figure 1 – Twelve-pulse converter unit**

Only line-commutated converters are covered in this document, which includes capacitor commutated converter circuit configurations. General ~~requirements for~~ aspects of semiconductor line-commutated converters are given in IEC 60146-1-1, IEC TR 60146-1-2 and IEC 60146-1-3. Voltage-sourced converters are not considered.

~~This technical report, which covers steady-state performance, is followed by additional documents on dynamic performance and transient performance. All three aspects should be considered when preparing two-terminal HVDC system specifications.~~

The ~~difference~~ distinction is made between system performance specifications and equipment design specifications for individual components of a system ~~should be realized~~. Equipment specifications and testing requirements are not defined in this document. Also excluded from this document are detailed seismic performance requirements. In addition, because there are many variations between different possible HVDC systems, this document does not consider these in detail; consequently, it ~~should~~ is not ~~be~~ used directly as a specification for a

particular project, but rather to provide the basis for an appropriate specification tailored to fit actual system requirements.

This document, which covers steady-state performance, is followed by the additional documents of IEC TR 60919-2 on faults and switching as well as IEC TR 60919-3 on dynamic conditions. All three aspects are considered when preparing two-terminal HVDC system specifications.

## 2 Normative references

The following documents are referred to in the text in such a way that some or all of their content constitutes requirements of this document. For dated references, only the edition cited applies. For undated references, the latest edition of the referenced document (including any amendments) applies.

~~IEC 60146-1-1, Semiconductor converters — General requirements and line commutated converters — Part 1-1: Specifications of basic requirements~~

~~IEC/TR 60146-1-2, Semiconductor converters — General requirements and line commutated converters — Part 1-2: Application guide~~

~~IEC 60146-1-3, Semiconductor converters — General requirements and line commutated converters — Part 1-3: Transformers and reactors~~

IEC 60633, ~~Terminology for~~ High-voltage direct current (HVDC) transmission – Vocabulary

CIGRÉ Technical Brochure (TB) No. 391:2009, *Guide for measurement of radio frequency interference from HV and MV substations. Disturbance propagation, characteristics of disturbance sources, measurement techniques, conversion methodologies and limits*

## 3 Terms and definitions

For the purposes of this document, the terms and definitions given in IEC 60633 apply.

ISO and IEC maintain terminological databases for use in standardization at the following addresses:

- IEC Electropedia: available at <http://www.electropedia.org/>
- ISO Online browsing platform: available at <http://www.iso.org/obp>

## 4 Types of HVDC systems

### 4.1 General

This part of the specification should include the following basic data:

- a) general information on the location of the HVDC substations and the purpose of the project;
- b) type of system needed, including a simple one-line diagram;
- c) number of 12-pulse converter units;
- d) pertinent information derived from the discussion in Clause 4.

Generally, in studies of projects of the types discussed in this document, economic considerations should take into account the capital costs, the cost of losses, cost of outages and other expected annual expenses.

In terms of the type of system, the ~~relatively new development of~~ "capacitor-commutated converter (CCC)" and "controlled series capacitor converter (CSCC)" technology may be suitable alternatives to a conventional HVDC scheme. These are described in 4.10.

#### 4.2 HVDC back-to-back system

In this arrangement there is no DC transmission line and both converters are located at one site. The valves for both converters may be located in one valve hall, or even in one integrated structure or separately as outdoor valves. Similarly, many other items for the two converters, such as the control system, cooling equipment, auxiliary system, etc., may be located in one area or even integrated in layout into configurations common to the two converters. Circuit configurations may vary. Examples are given in Figure 2. The performance and economics of these configurations differ and ~~must~~ should be evaluated. DC filters are not needed.

The voltage and current ratings for a given power rating should be optimized to achieve the lowest system cost, including the evaluated cost of losses. Ordinarily, the user does not need to specify the direct voltage and current ratings, unless there are specific reasons to do so, for example, for compatibility with an already existing station, to provide for a future extension or for some other reason. Economics dictate that each converter will usually be a 12-pulse converter unit, however it is not mandatory. Where operating criteria require that the loss of one converter unit will not cause loss of full power capability, large HVDC substations could be comprised of two or more back-to-back systems. For this, some of the equipment of the back-to-back systems can, for economic reasons, be located in the same area or even physically integrated, but events which could cause a failure of equipment required by all back-to-back systems need to be carefully considered and preventive measures taken where appropriate.

#### 4.3 Monopolar HVDC system with earth return ~~HVDC system~~

Cost considerations often lead to the adoption of a monopolar HVDC system with earth return ~~system~~ (Figure 3), particularly for cable transmission which may be expensive.

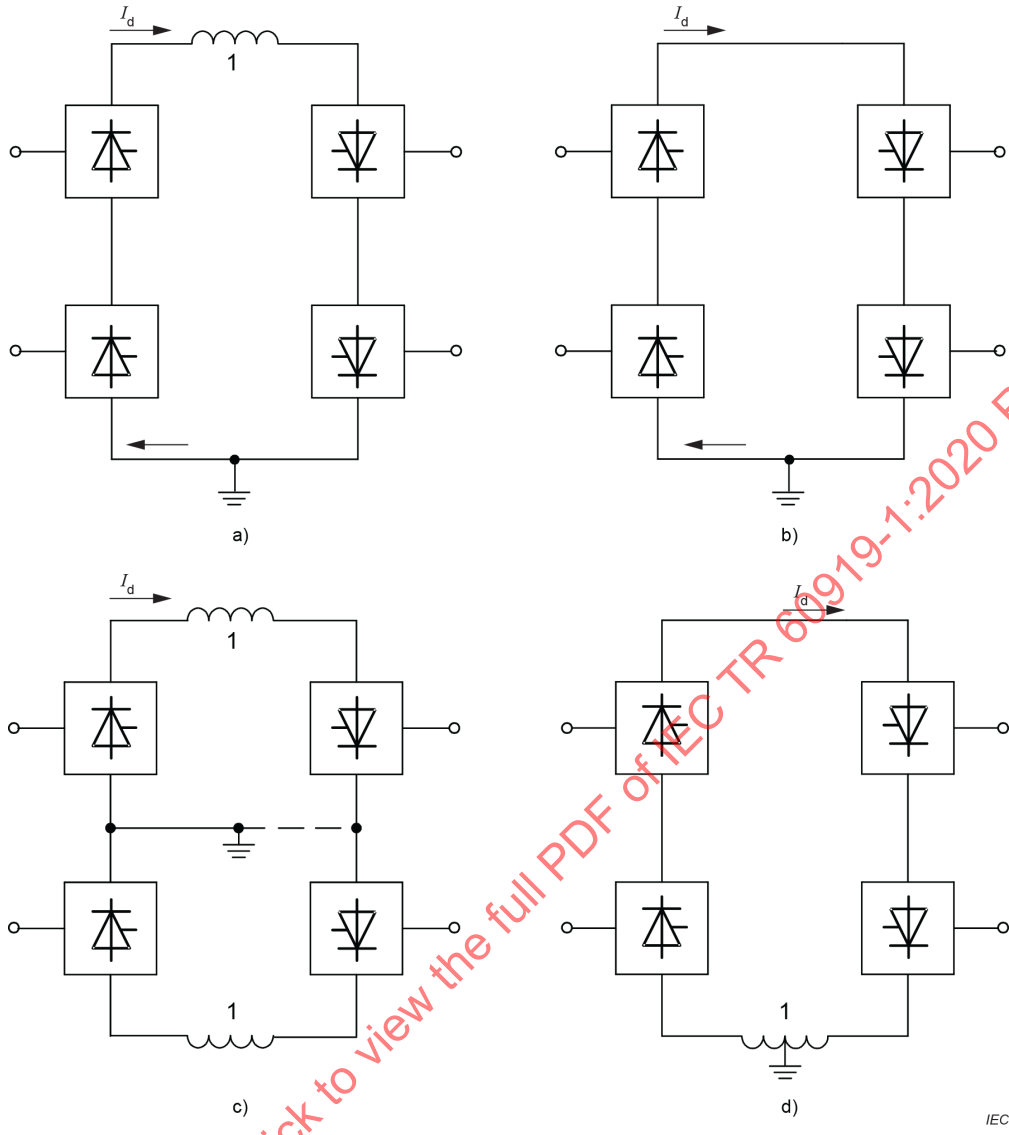

**Key**

1 DC reactor

**Figure 2 – Examples of back-to-back HVDC systems**

IECNORM.COM : Click to view the full PDF of IEC TR 60919-1:2020 RLV

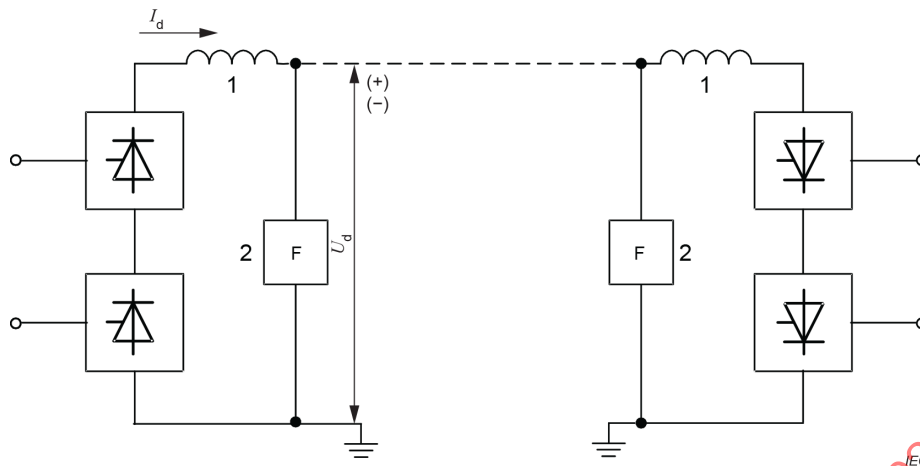
**Key**

- 1 DC reactor
- 2 DC filters

**Figure 3 – Monopolar HVDC system with earth return**

The monopolar earth return configuration might also be the first stage in the development of a bipolar scheme. Monopolar arrangements may include one or more 12-pulse units in series or in parallel at the ends of the HVDC transmission (Figure 4 and Figure 5). More than one 12-pulse unit ~~might~~ can be used for the following purposes:

- a) to ensure partial transmission capacity during converter unit outages;
- b) to complete the project in stages;
- c) because of the physical limitations of transformer transport.

This arrangement requires one or more DC reactors at each end of the HVDC overhead line or cable; these are usually located on the high-voltage side. ~~However, the d.c. reactors may be divided into two parts and located on the high-voltage side and the earth side respectively if the resulting performance is acceptable, especially for a large scale ultra high voltage direct current (UHVDC) converter arrangement.~~

If the line is overhead, DC filters are likely to be needed at each end (see Clause 18). It also requires an earth electrode line and a continuously operable earth electrode at the two ends of the transmission which involves consideration of issues such as corrosion, magnetic field effects, etc.

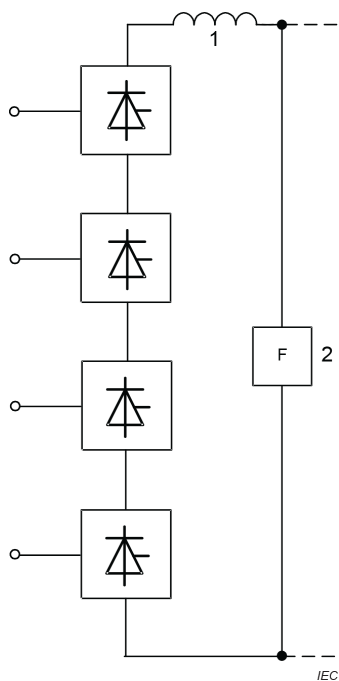

**Key**

- 1 DC reactor
- 2 DC filter

**Figure 4 – Two 12-pulse units in series**

IECNORM.COM : Click to view the full PDF of IEC TR 60919-1:2020 RLV

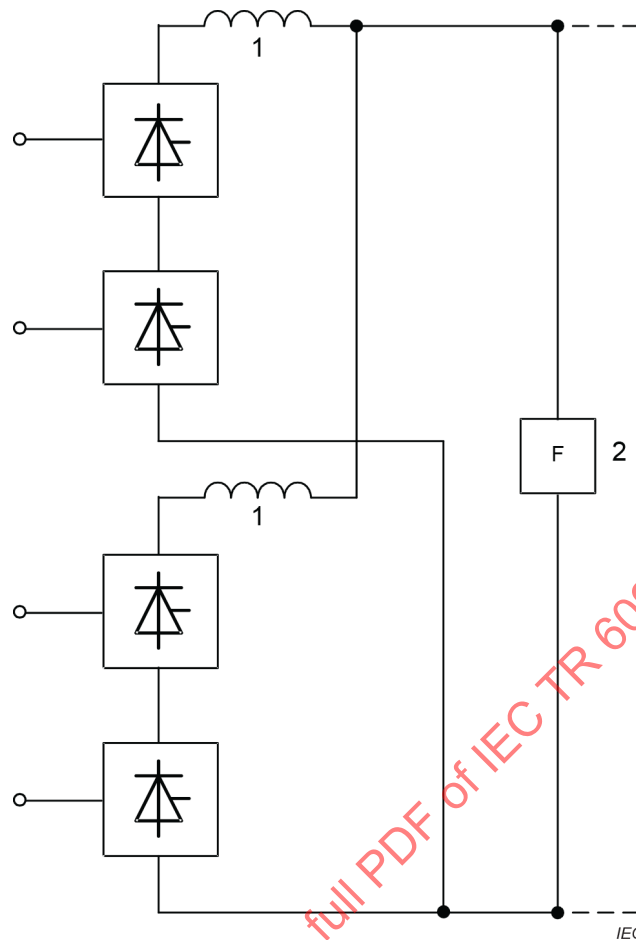
**Key**

- 1 DC reactor
- 2 DC filter

**Figure 5 – Two 12-pulse units in parallel****4.4 Monopolar HVDC system with metallic return-HVDC system**

The configuration as illustrated in Figure 6 will generally be used for the following purposes:

- a) as the first stage in the construction of a bipolar system and if long-term flow of earth current is not desirable during the interim period, or
- b) if the transmission line length is short enough to make it uneconomic and undesirable to build earth electrode lines and earth electrodes, or
- c) if the earth resistivity is high enough to impose an unacceptable economic penalty, or
- d) if long-term flow of earth current is unacceptable because of environmental and safety requirements.

This configuration utilizes one high-voltage and one low-voltage conductor. The neutral is connected at one of the two HVDC substations to its station earth or, alternatively, to the associated earth electrode. The other HVDC substation neutral is connected to its station earth through a capacitor or an arrester or both.

DC reactors are needed at both ends of the high-voltage conductor. However, the DC reactor may be located on the earth side if the resulting performance is acceptable. However, the DC reactors may be divided into two parts and located on the high-voltage side and the earth side respectively if the resulting performance is acceptable, especially for a large scale ultra-high-

voltage direct-current (UHVDC) converter arrangement. DC filters may be needed if the HVDC transmission line is overhead.

If this configuration is the first stage of a bipolar system, its neutral conductor could be insulated for the high voltage at this stage of development.

For a metallic return scheme, DC fault current will flow into the AC system and come back through neutral point of transformers installed in the converter station. This current may lead to the malfunction of protective relays installed in nearby stations, caused by the saturation of cores due to DC current. To prevent such malfunctions, insertion of neutral grounding resistor (small resistance) to transformers in the converter station will be effective.

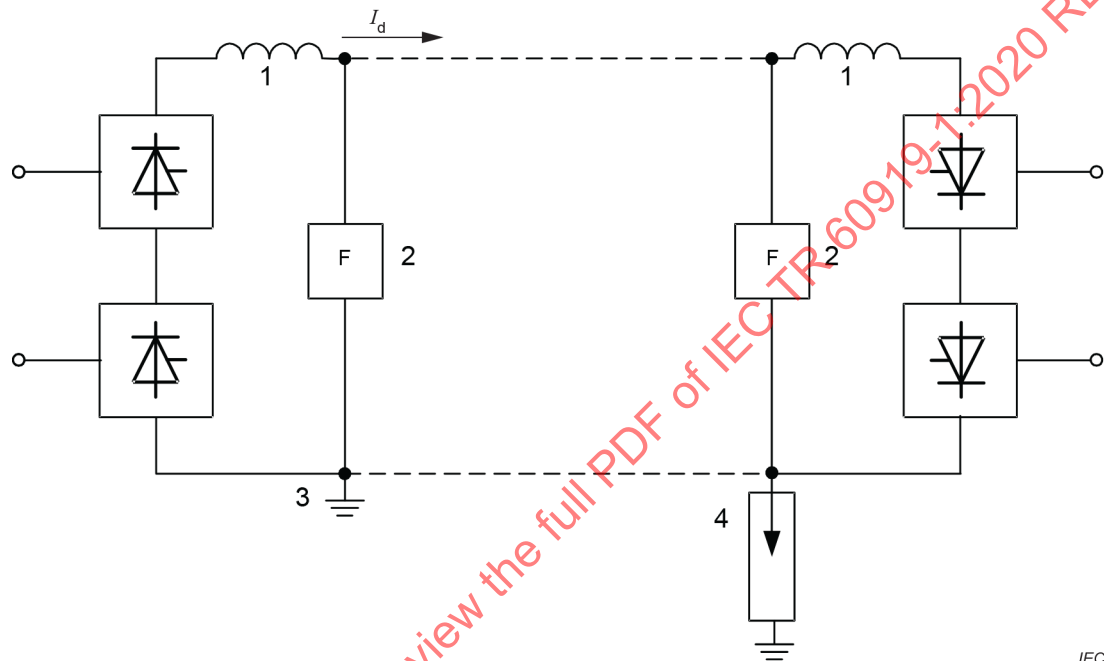

IEC

**Key**

- 1 DC reactor
- 2 DC filter
- 3 Station earth
- 4 Arrester

**Figure 6 – Monopolar HVDC system with metallic return-system**

**4.5 Bipolar earth return HVDC system**

This is the most commonly used arrangement when a DC transmission line connects two HVDC substations and electrodes for earth return operation are provided (Figure 7 (a)). It is effectively equivalent to a double-circuit AC transmission. It reduces harmonic interference from the DC line as compared with monopolar operation and it keeps earth current flow down to a low value. When combined, two monopolar earth return schemes can give a bipolar scheme.

For power flow in one direction, one pole has positive polarity to earth and the other pole has negative polarity to earth. For power flow in the other direction, the two poles reverse their polarities. When both poles are in operation, the unbalance current flowing in the earth path can be kept at a very low value.

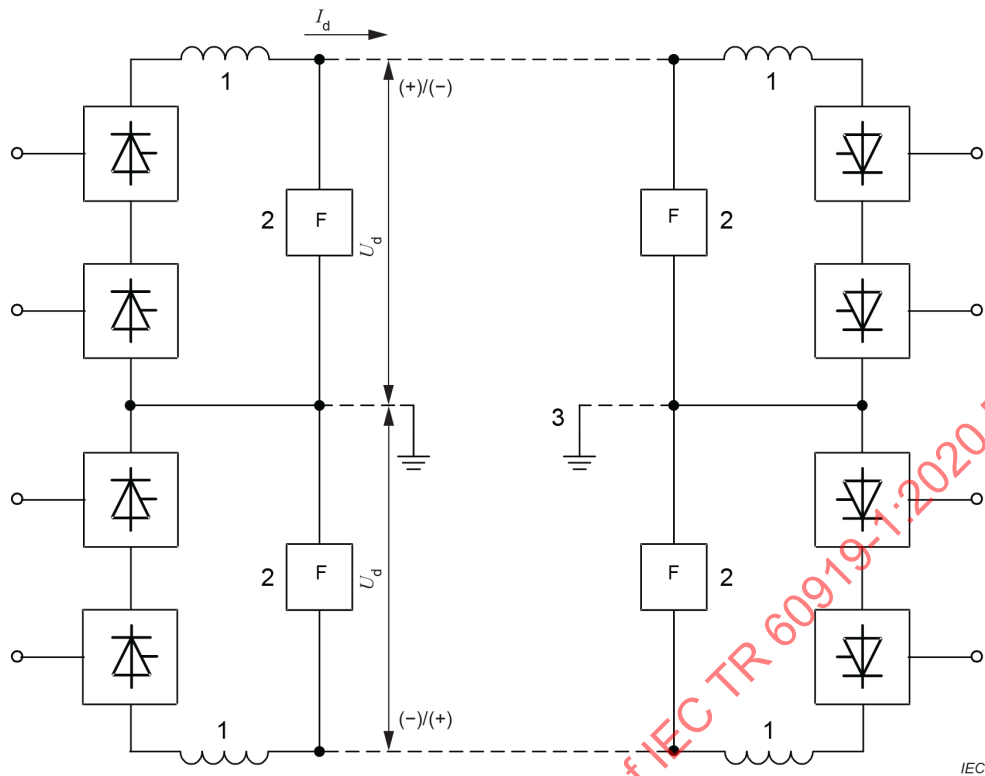

Figure 7 a) – Bipolar HVDC system with earth return

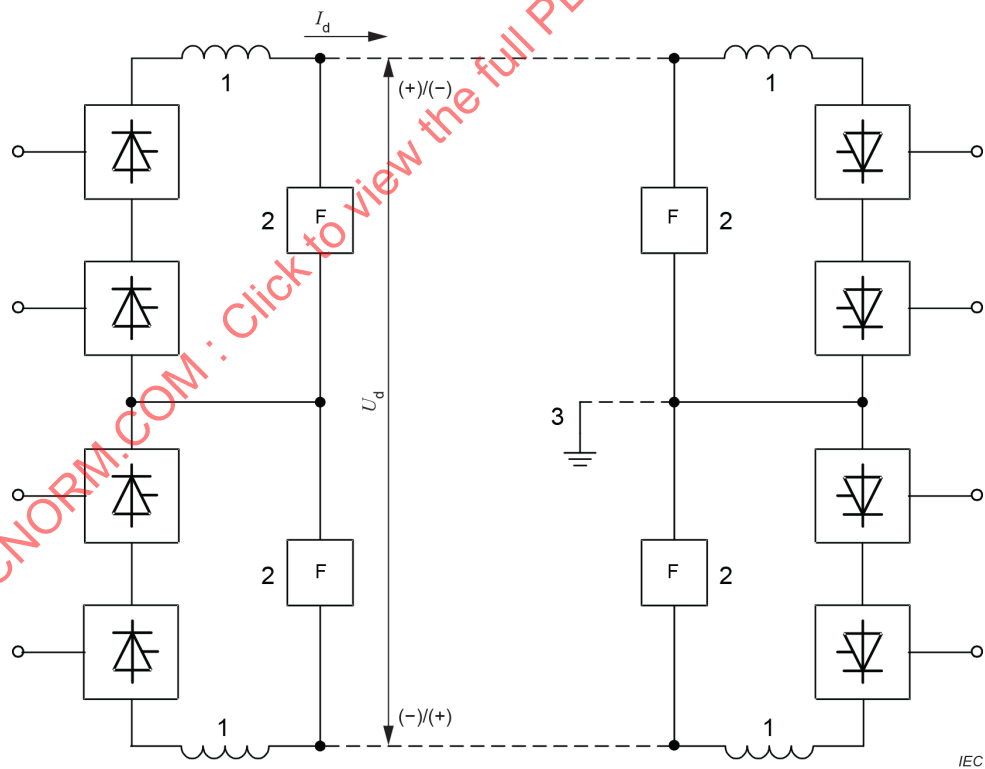

Figure 7 b) – Rigid bipolar HVDC system

**Key**

- 1 DC reactor
- 2 DC filter
- 3 Earth electrodes

**Figure 7 – Bipolar system**

This configuration offers a number of emergency operating modes. Consequently, the requirements in the following list a) to f) should be considered in the specifications.

- a) During an outage of one HVDC transmission line pole 11 in Figure 8 (rectifier DC switches 3 and inverter DC switches 9 have been switched off), the converter equipment of the other pole 12 should be capable of continuous operation with earth return (rectifier DC switches 4, inverter DC switches 10, earth return transfer switch (ERTS) 7 and metallic return transfer breaker (MRTB) 8 have been switched on).
- b) If long-term flow of earth current is undesirable and if the defective line pole still retains some low-voltage insulating capability, the bipolar system should be capable of operation in the monopolar metallic return mode (Figure 8). To switch into this emergency operating mode the conductor of the out-of-service pole 11 is first connected in parallel with the earth path by switching on pole-to-neutral switches 5 and then the earth path is interrupted to transfer the current to the metallic path (through the conductor of the out-of-service pole) by switching off MRTB 8. Load transfer without interruption requires a metallic return transfer breaker (MRTB) at one terminal of the DC transmission. If a short interruption of power flow is permitted, MRTB would not be necessary. The neutral equipment at the MRTB end of the HVDC transmission system should be insulated from earth for a somewhat higher voltage than at the other end of the system. Figure 8, with DC switches 3 and 4 (named as ERTS and MRTB), is usually valid for a rectifier station. The MRTB is not necessary for the inverter station.

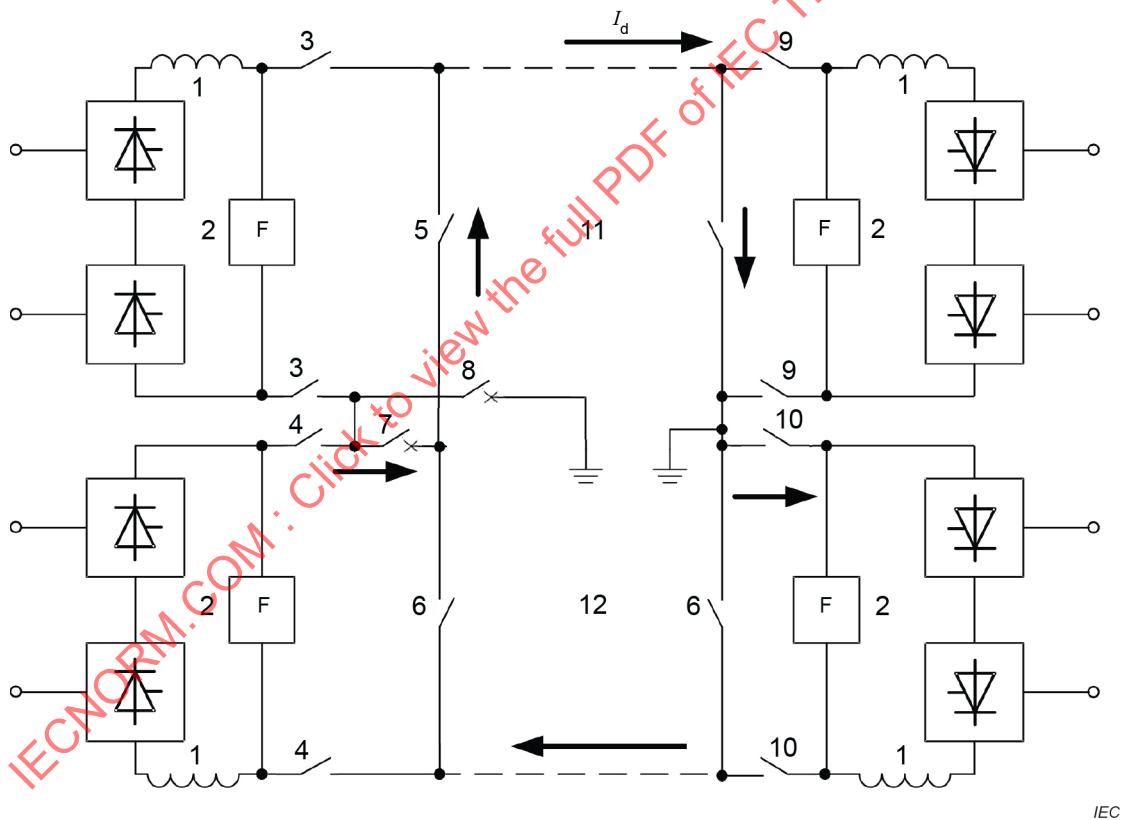

IEC

**Key**

- |     |                          |        |   |
|-----|--------------------------|--------|---|
| 1   | DC reactor               | 7      | Earth return transfer switch (ERTS)     |
| 2   | DC filter                | 8      | Metallic return transfer breaker (MRTB) |
| 3,4 | Rectifier DC switches    | 9,10   | Inverter DC switches                    |
| 5,6 | Pole-to-neutral switches | 11, 12 | HVDC power transmission poles           |

**Figure 8 – Metallic return operation of the unfaulted pole in a bipolar system**

- c) During maintenance of the earth electrode(s) or the earth electrode line(s), operation of the bipolar system should be possible with the station neutral(s) connected to the station earth at one or both HVDC substations as long as the unbalance current between the two poles entering the station earth(s) is kept at a very low value. The unbalance current

should be kept low to avoid saturation effects in the converter transformers from the flow of part of the unbalance current through the transformer neutrals. In this arrangement when one transmission line of substation pole is lost, both poles should be blocked automatically.

- d) In bipolar operation with both earth electrodes connected, the two poles of the HVDC system should be capable of operation with substantially different currents in each pole. This may be necessary if loss of cooling or some other unusual condition prevents the operation of one pole with full current.
- e) If continuation of operation is required in the case of poor weather conditions or where the line insulation has been partially damaged, the converters should be designed for continuous operation at reduced voltage, so that either pole can be operated at reduced voltage (see 8.3).
- f) In the event of the loss of one transmission line pole, the two substation poles can also be connected in parallel by using appropriate switches for polarity reversal in at least one station pole enabling both poles to operate in the monopolar earth return mode. This, however, requires that the DC terminals of each 12-pulse group be insulated for the full pole voltage and the line and the earth electrode shall be thermally capable of carrying a current higher than the normal current.

One or more DC reactors is needed at each end of the system in each pole, these are usually located on the high-voltage side. However, the DC reactors may be divided into two parts and located on the high-voltage side and the earth side respectively if the resulting performance is acceptable, especially for a large scale ultra-high-voltage direct-current (UHVDC) converter arrangement. If the HVDC system includes an overhead line, DC filters would most likely be needed. One 12-pulse unit per pole is most commonly used; however, large capacity systems or staged expansion may require 12-pulse units in series or in parallel (Figure 4 and Figure 5).

Most HVDC systems utilise ground return or a dedicated metallic return conductor for the DC current path. However, when balanced bipolar operation can always be ensured, these facilities can be eliminated. This scheme is called "rigid bipole HVDC system" configuration, as shown in Figure 7 b). With this scheme, operation modes are limited but installation cost can be reduced.

#### 4.6 Bipolar HVDC system with metallic return HVDC system

If earth currents are not tolerable (as mentioned in 4.4, item d)) or if the distance between the HVDC system terminals is short, or if an earth electrode is not feasible because of high earth resistivity, then the transmission line may be constructed with a third conductor to give a bipolar HVDC system with metallic return HVDC system (Figure 9). The third conductor carries unbalance currents during bipolar operation. It also serves as the return path when one transmission line pole is out of service. This third conductor requires only reduced voltage insulation and, in this case, may also serve as a shield wire if the line is overhead. However, if it is fully insulated, it can serve as a spare conductor. In this case, a separate shield wire is required.

The neutral of one of the two HVDC substations should be earthed, while the neutral at the other end of the transmission would float or be tied to its station earth through an arrester, a capacitor or both.

With this design, the system can still be operated in the bipolar mode if one conductor becomes unavailable and the third conductor is fully insulated. Then, the neutrals at both terminals should be connected to their local station earths, and care should be taken to hold the unbalanced current flow to very low values. Loss of one pole will require blocking of the other pole until the necessary switching has taken place for operation of the remaining sound portions of the HVDC transmission system.

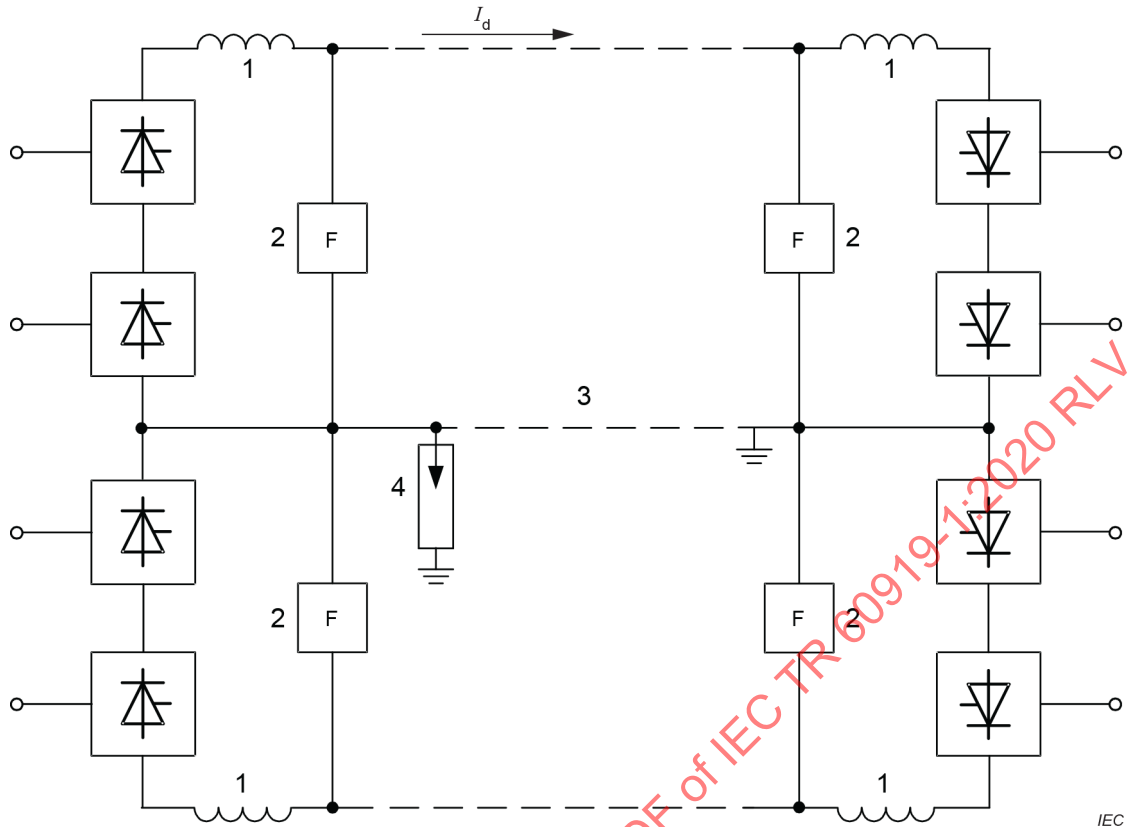

**Key**

- 1 DC reactor
- 2 DC filter
- 3 Metallic neutral
- 4 Arrester

**Figure 9 – Bipolar ~~metallic return~~ HVDC system with metallic return**

If one ~~substation~~ pole becomes unavailable, the system can be operated in monopolar metallic return mode by utilizing the other substation pole. This configuration is also called "metallic return mode" (MRM).

For a metallic return scheme, DC fault current will flow into the AC system and partly come back through neutral point of transformers installed in the converter station. This current may lead to the malfunction of protective relays installed in nearby stations, because of saturation due to DC current. To prevent such malfunctions, insertion of neutral grounding resistor (small resistance) to transformers in converter station will be effective.

**4.7 Two 12-pulse groups per pole**

For a high-power ultra-high-voltage direct-current (UHVDC) converter arrangement, two 12-pulse units per pole may be a better solution to achieve required rating, because the dimension and weight of converter equipment (especially converter transformer) would become too large if only one 12-pulse unit per pole were used.

Two 12-pulse converters can be connected in series (Figure 10) or in parallel (Figure 11), and the selection of converter arrangement depends on the specific requirements of the project. On the other hand, if a project requires reduced voltage operation, for instance, due to occasional salt contamination, then the series option ~~should~~ may be ~~selected~~ preferred.

~~Basically series/parallel option has no difference regarding loss of~~ The series and parallel options are equivalent in terms of loss of transmitting power when a forced or scheduled outage of a 12-pulse converter occurs. In both cases, only 25 % of the capacity will be lost, assuming all converters have the same power rating ~~converters are employed~~. If sufficient overload capability is available, full power or almost full power can be restored. For the series option, the two poles can still operate with balanced current (without earth current) after a forced or scheduled outage of a 12-pulse converter occurs. However, note that a by-pass switch is required for each 12-pulse converter in series connected option. For the parallel option, the two poles can still operate with unbalanced current when a forced or scheduled outage of a 12-pulse converter occurs, while there is large current flowing through earth.

IECNORM.COM : Click to view the full PDF of IEC TR 60919-1:2020 RLV

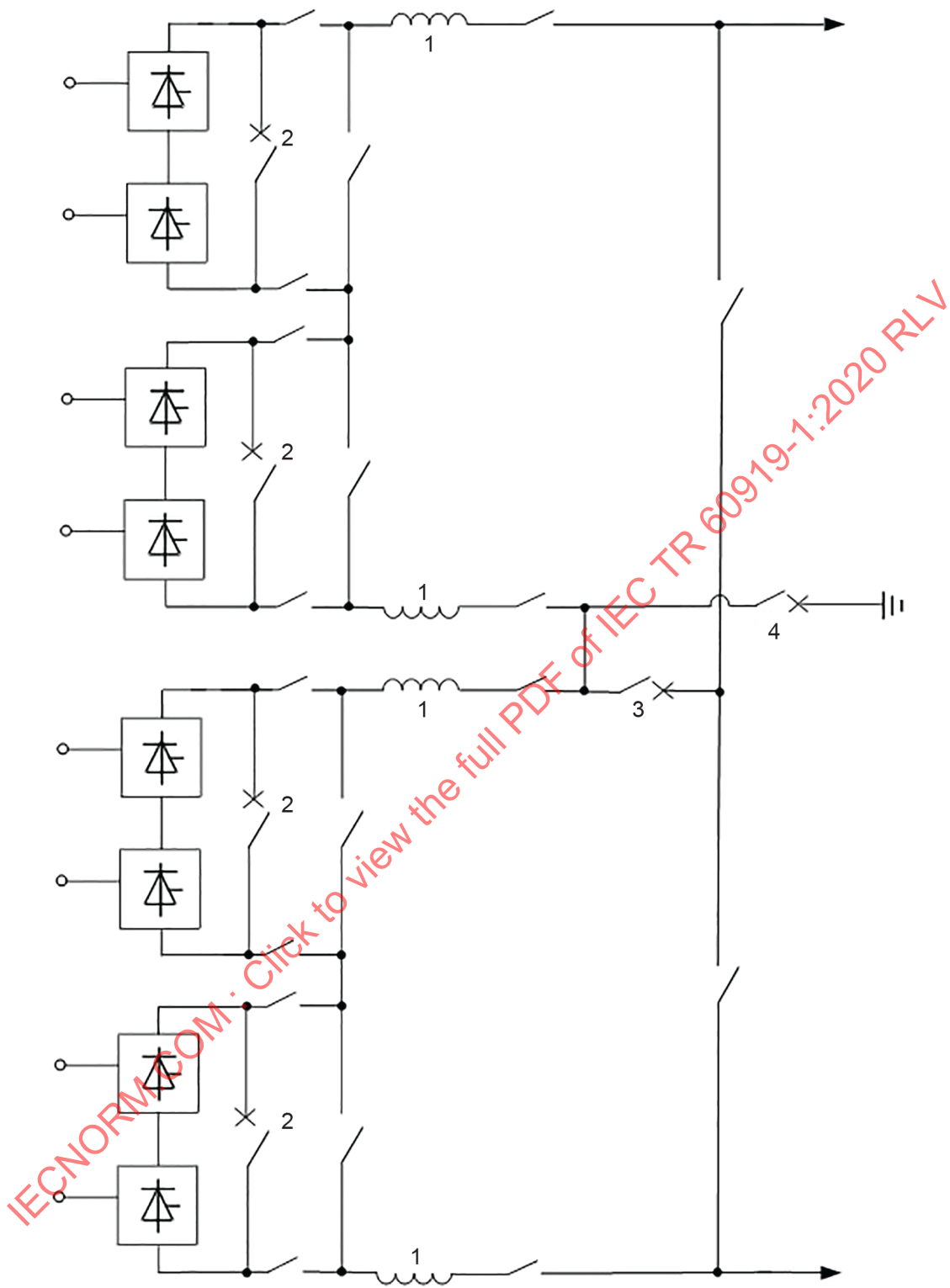

IEC

**Key**

- 1 DC reactor
- 2 By-pass switch
- 3 Earth return transfer switch (ERTS)
- 4 Metallic return transfer breaker (MRTB)

**Figure 10 – Bipolar system with two 12-pulse units in series per pole**

The cost of the two 12-pulse group per-pole arrangement, compared to one 12-pulse group per pole for the same total rating, would be expected to be greater, and the control system will become more complicated.

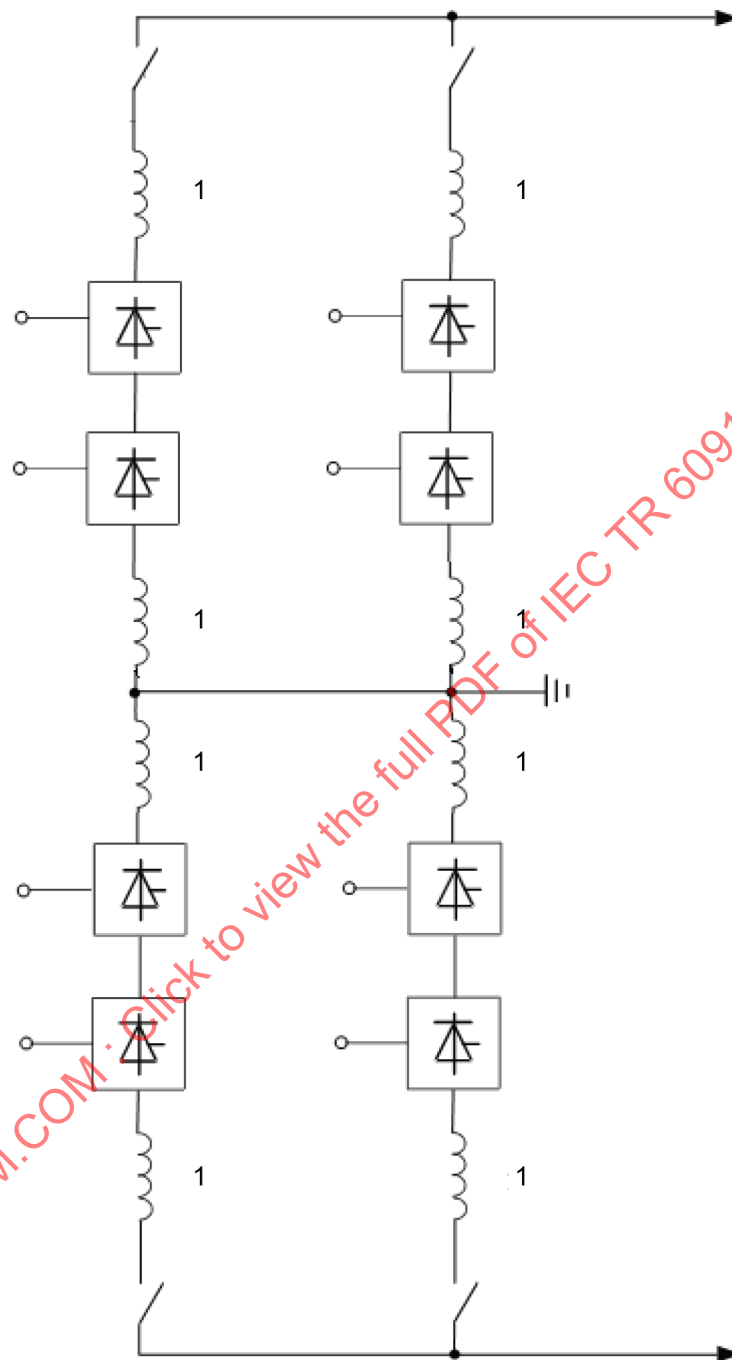

IEC

**Key**

1 DC reactor

**Figure 11 – Bipolar system with two 12-pulse units in parallel per pole**

#### 4.8 Converter transformer arrangements

Each 12-pulse converter requires two three-phase transformer valve windings, one star-connected and the other delta-connected. These are provided by ~~either~~ one of the following:

- a) one three-phase transformer with two valve windings, or
- b) two three-phase transformers, one connected star-star and the other star-delta, or
- c) three single-phase transformers each with two valve windings, one for star connection and the other for delta connection, or
- d) six single-phase transformers, connected in two three-phase banks, one connected star-star and the other star-delta.

Depending on the HVDC system availability requirements, spare transformers may be needed at one or both ends. If one three-phase transformer with two valve windings is used, only one spare unit would be required. Since the star- and delta-connected three-phase transformers would be of different designs, spares considerations would indicate one spare of each design. Only one spare would be required for the single-phase, double-valve winding transformers since all three would be identical. The last of the above options would suggest two spare transformers, one each for the star- and the delta-valve winding single-phase transformers.

If spare transformers are not employed, alternatives b) and d) above allow for six-pulse operation at half-power in case of a transformer outage, if the HVDC system is designed for this mode of operation and the AC and DC harmonic conditions ~~would be~~ are acceptable. Six-pulse operation is not possible with alternatives a) and c).

It is not always needed to split the DC reactors, especially for parallel connection. The number and arrangement of DC reactors depend on the results of system studies and design.

Converter transformers with a tertiary winding for reactive power and AC harmonic filter equipment may also be used.

#### 4.9 DC switching considerations

There are a number of possible DC switching arrangements intended to increase HVDC system availability.

Monopolar metallic return operation of a bipolar system is discussed in 4.5.

For bipolar systems, DC switching may be provided (Figure 12) so as to allow the use of any conductor for connection to any substation pole or to neutral. This arrangement is useful for a scheme involving cables and where a fully insulated spare cable is available or cables are connected in parallel. If one substation pole is out of service, then the cables can be paralleled to reduce line losses. Generally, DC buses are fixed in relation to converters, with two pole buses and a neutral bus. This would preclude connection of the two substation poles in parallel.

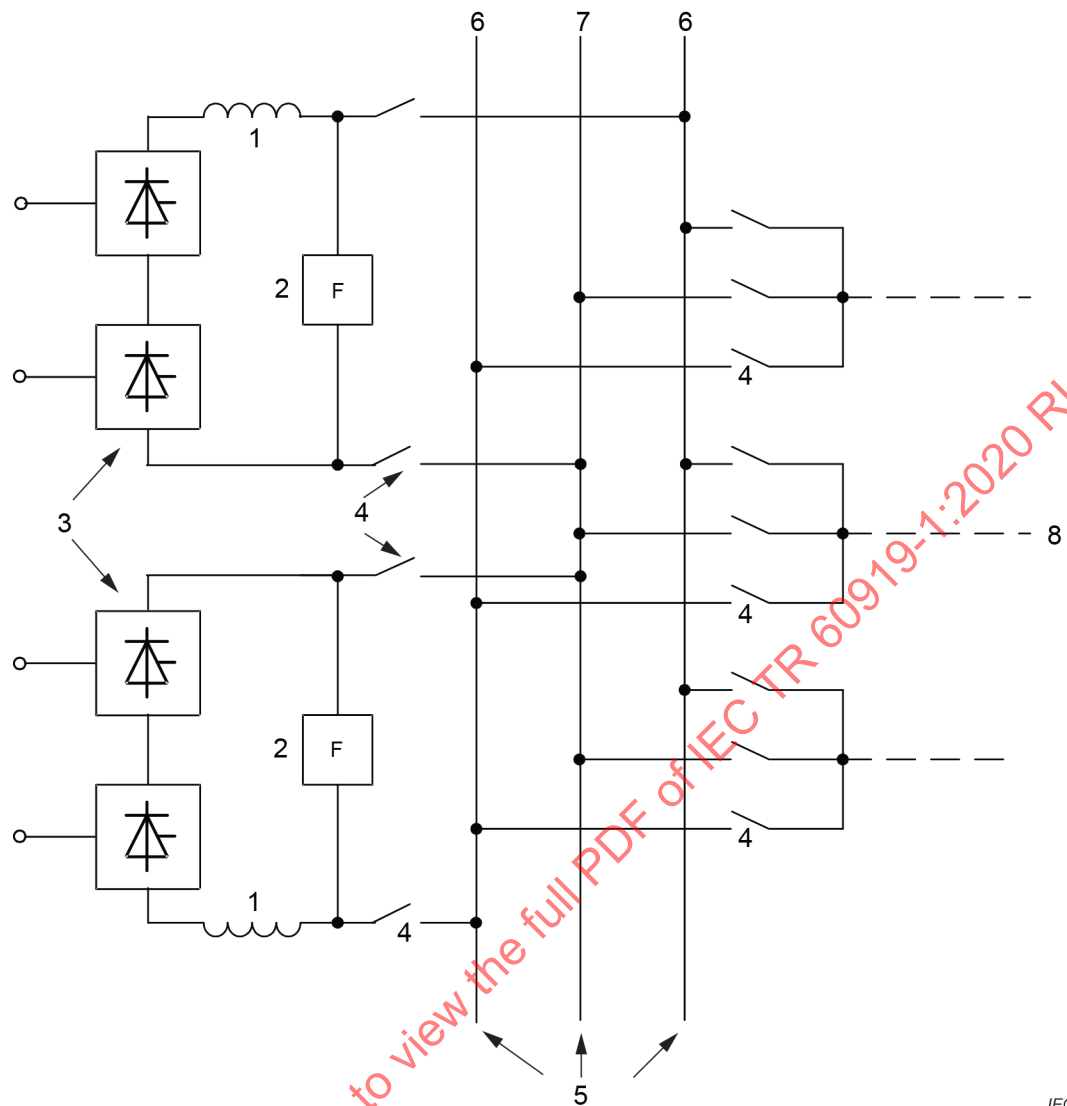
**Key**

1	DC reactor	5	DC bus
2	DC filter	6	Pole
3	Two-converter poles	7	Neutral
4	DC switches	8	DC line/cable

**Figure 12 – DC switching of line conductors**

However, if flexibility of connecting the two substation poles in parallel is needed, then provision for polarity reversal of at least one substation pole could be made and the neutral end of that substation pole will also have to be insulated for full line voltage. A possible switching arrangement is shown in Figure 13.

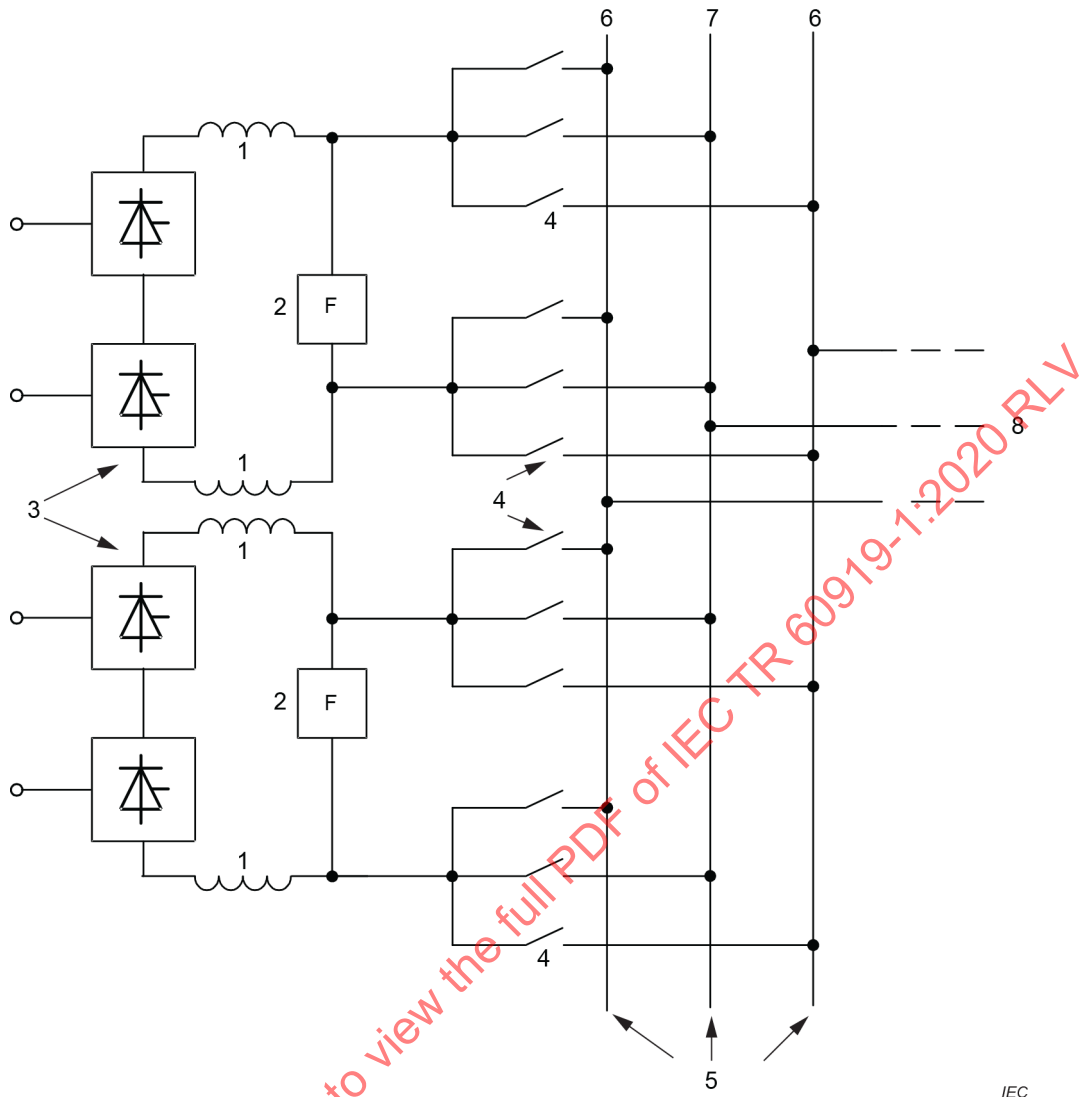

**Key**

- |   |                     |   |               |
|---|---------------------|---|---------------|
| 1 | DC reactor          | 5 | DC bus        |
| 2 | DC filter           | 6 | Pole          |
| 3 | Two-converter poles | 7 | Neutral       |
| 4 | DC switches         | 8 | DC line/cable |

**Figure 13 – DC switching of converter poles**

If an HVDC transmission system includes both overhead line and cable sections, a DC switching arrangement such as in Figure 14 may be used at the junction of the overhead and cable sections.

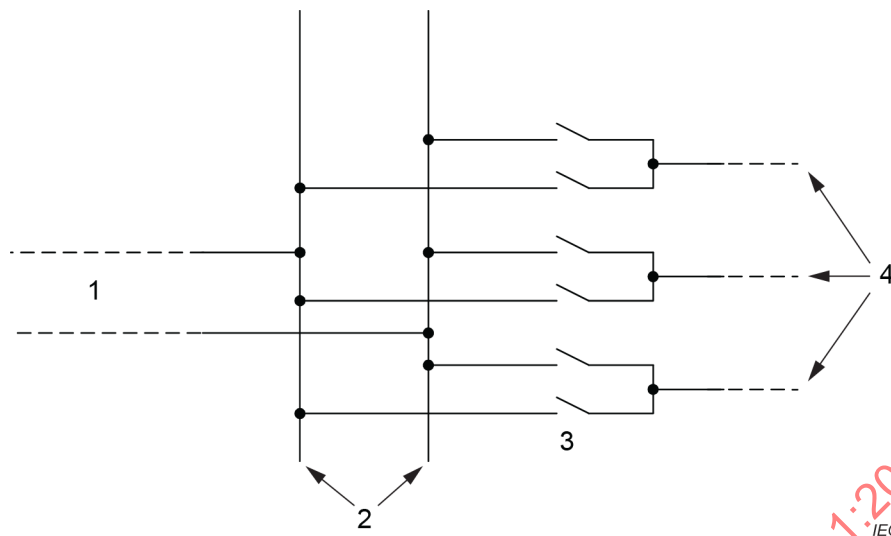
**Key**

- 1 Bipolar overhead line
- 2 DC bus
- 3 DC switches
- 4 DC cables (two poles, one spare)

**Figure 14 – DC switching – Overhead line to cable**

For more than one bipolar line, paralleling of converter poles may be considered, in order to allow restoration of transmission capability (Figure 15) for transmission line outages.

For long bipolar lines in parallel, intermediate switching such as in Figure 16 may be provided.

#### 4.10 Series-capacitor-compensated HVDC systems

Although the conventional line-commutated converter (LCC) technology has reached maturity, such converters still have two weaknesses:

- a) a large amount of reactive power consumption, roughly 50 % of its active power;
- b) susceptibility to AC side disturbance, commonly observed as commutation failures.

To overcome these weaknesses, further developments have been made using series-capacitor compensation.

Practically, there are two types of series-capacitor compensated HVDC schemes.

- Capacitor-commutated converter (CCC), in which series capacitors are included between the converter transformer and the valves.
- Controlled series capacitor converter (CSCC) is also suggested. In this scheme, the basic topology of the converter is the same as the conventional topology; however, series capacitors are inserted between the AC filter bus and the AC network. Occurrence of ferroresonance with the CSCC option is eliminated by controlling the amount of series compensation.

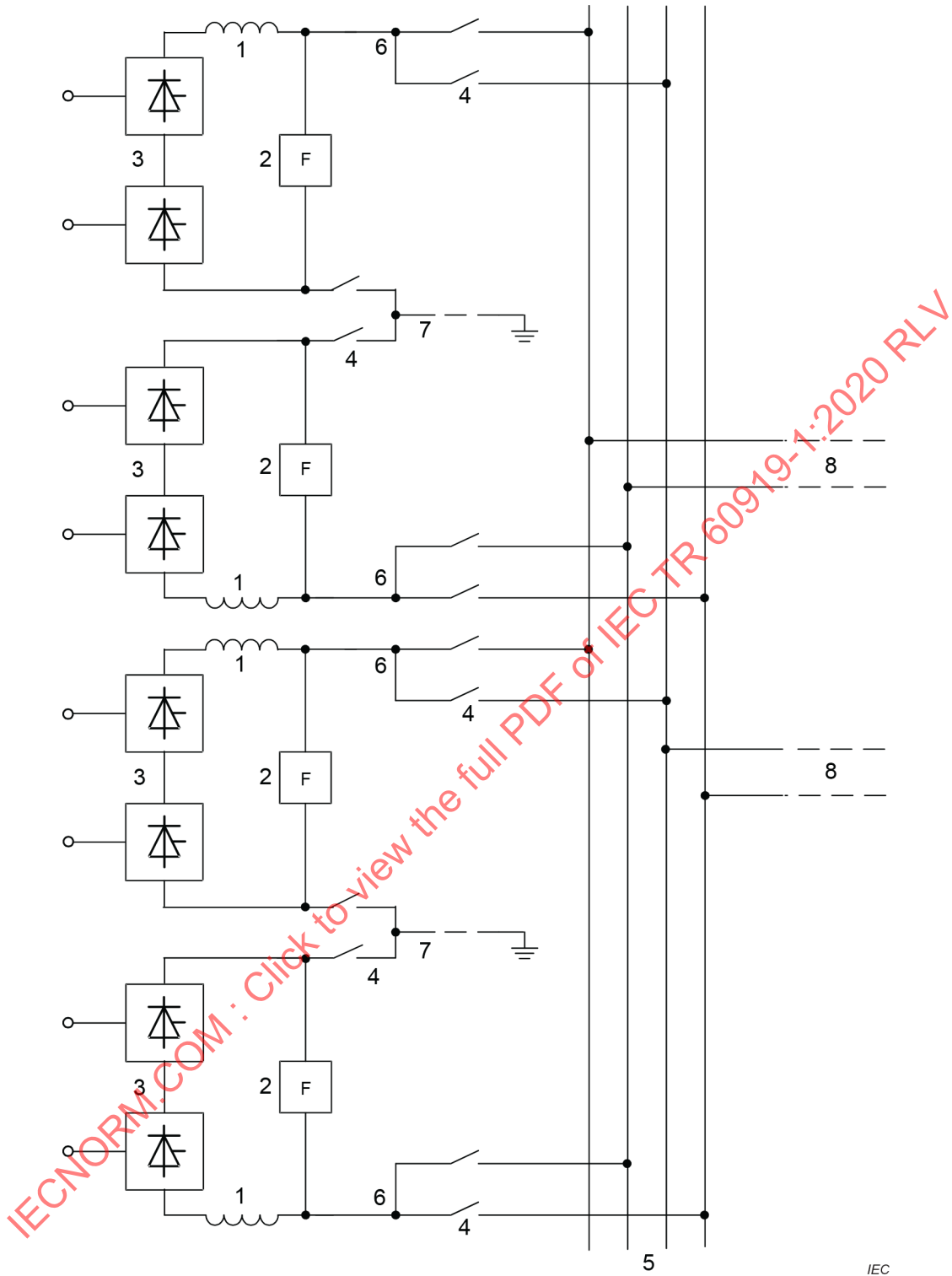

**Key**

- |   |                     |   |               |
|---|---------------------|---|---------------|
| 1 | DC reactor          | 5 | DC bus        |
| 2 | DC filter           | 6 | Pole          |
| 3 | Two-converter poles | 7 | Neutral       |
| 4 | DC switches         | 8 | DC line/cable |

**Figure 15 – DC switching – Two bipolar converters and lines**

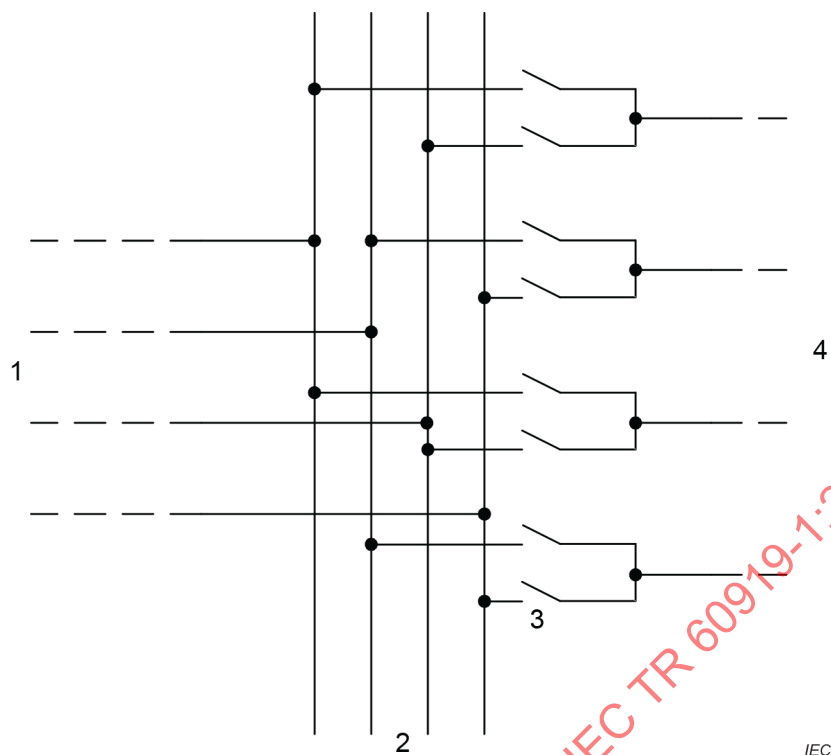
**Key**

- 1 Two bipolar lines
- 2 DC bus
- 3 DC switches
- 4 Two bipolar lines

**Figure 16 – DC switching – Intermediate**

The CCC circuit shown schematically in Figure 17 a) is based on a topology in which series capacitors are included between the converter transformer and the valves. The CSCC circuit has the series capacitors inserted at the connection of the filter bus to the AC system as shown in Figure 17 b). This provides similar performance to the CCC, with the additional advantage of controllability of the reactive power exchange with the AC network.

Both alternatives offer improved immunity from commutation failure, lower load rejection overvoltages and increased stability margins in power control mode, over the conventional HVDC scheme. They are, therefore, suitable candidates for use at the inverter end in long cable systems or in back-to-back ties connected to weak AC systems. The performance of the two alternatives is very similar for steady state as well as transient operation.

The maximum valve voltages and also the AC current harmonics for the CSCC configuration are lower than for the CCC configuration. On the other hand, the CCC in rectifier operation exhibits a smaller valve short-circuit current. The previously identified problem with ferroresonance in the CSCC is eliminated through the application of controlled series capacitors.

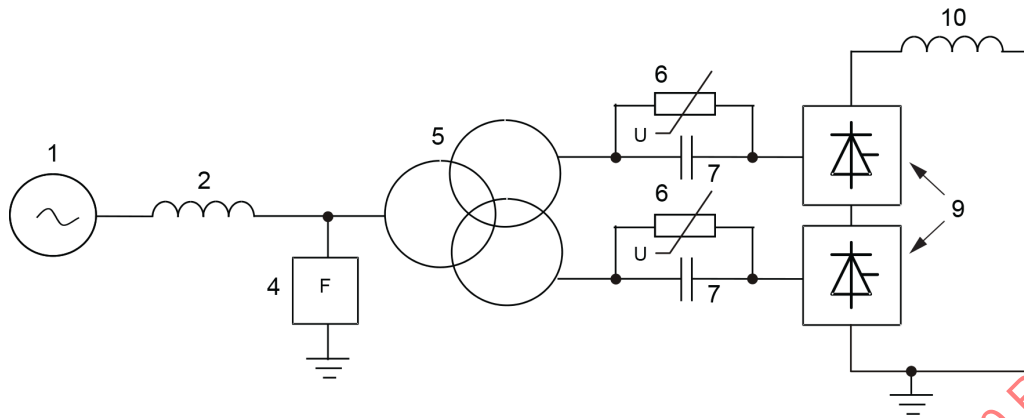

a) Capacitor commutated converter (CCC)

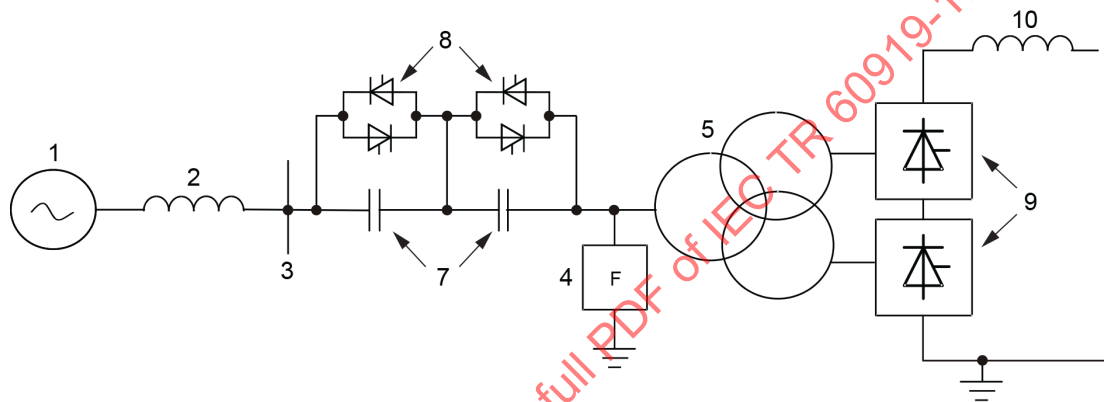

b) Controlled series capacitor converter (CSCC)

**Key**

1	AC system e.m.f.	6	Overvoltage limiter
2	AC system impedance	7	Capacitor
3	AC system bus	8	Thyristors
4	AC filters	9	Converters
5	Converter transformer	10	DC reactor

**Figure 17 – Capacitor commutated converter configurations**

The advantages of using CCC in comparison with conventional converter may be summarized as follows:

- significantly less reactive power consumption, which, in combination with sharply tuned filter branches, eliminates the need for switching filter and shunt capacitor banks during power ramps;
- immunity to commutation failure during AC side disturbance, which is beneficial with long lines or cables feeding weak AC networks;
- stable operation in lower short-circuit capacity systems;
- lower overall installation cost in some cases, due to elimination of switchable filter and shunt capacitor banks or synchronous compensators, in applications associated with weak AC network connections;
- robustness in situations of converter-arm short-circuit fault due to lower fault current;
- less variation of reactive power during disturbances, which results in improved power quality and reduced load rejection.

The disadvantages are:

- increased harmonic current;
- slightly increased converter losses;
- requirement for detailed study of transient stresses on equipment;
- reduced inherent overload capability, due to the capacitor connected in series with the converter;
- requirement for shielding against lightning and radio interference between the valve winding, the capacitor and the valve;
- slightly increased valve voltage stress.

When CCC or CSCC is being considered as an HVDC topology for a particular project, it should be emphasized that the selection of optimal system rating is different from conventional HVDC. Therefore, in order to make a selection between conventional HVDC schemes and these alternatives, a detailed analysis is required with respect to economics and technical performance, taking into account losses, installation costs, etc.

#### 4.11 LCC/VSC hybrid bipolar system

In case one pole of the LCC is combined with a VSC pole, a hybrid bipolar system of LCC and VSC will be formed. For an LCC/VSC hybrid bipolar system, special consideration should be taken because power reversal of the VSC system requires current reversal, whereas LCC changes voltage polarity. The combined operation of both systems will lead to excessive current on electrode line or return line for one of the power directions. In order to prevent this problem, switches for polarity reversal should be installed on the VSC converter, as depicted in Figure 18.

The other possibility of LCC/VSC hybrid system is the case that consists of LCC for one terminal and VSC for the other terminal. This configuration can be applied to the DC system that transmits power to a weak AC system.

Adopted VSC for hybrid systems should be in asymmetrical monopole configuration.

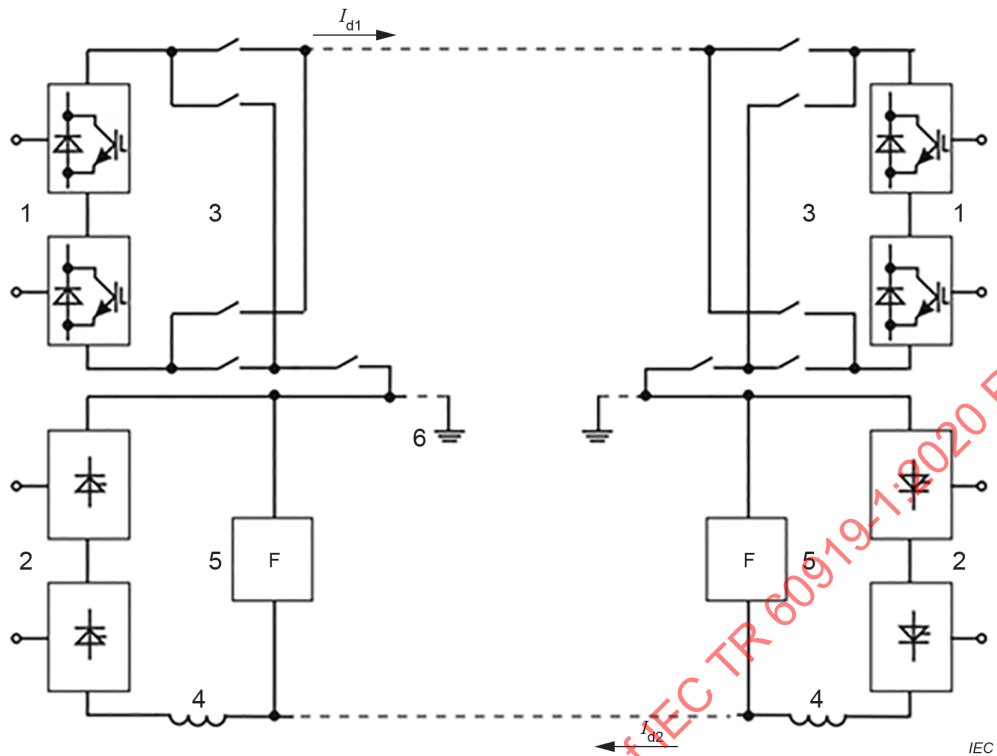

**Key**

- |   |                                 |   |                 |
|---|---------------------------------|---|-----------------|
| 1 | voltage-sourced converter (VSC) | 4 | DC reactor      |
| 2 | line-commutated converter (LCC) | 5 | DC filter       |
| 3 | polarity reversal switches      | 6 | earth electrode |

**Figure 18 – LCC/VSC hybrid bipolar system**

**5 Environment information**

The location and the information listed in Table 1 should be supplied for each HVDC substation.

IECNORM.COM : Click to view the full PDF of IEC TR 60919-1:2020 RLV

**Table 1 – Information supplied for HVDC substation**

Parameter	Unit		Examples of use and comments
Height above sea-level	m		For the design of air-cooling systems and for air clearances
Outdoor air temperature	°C		The maximum temperatures are given for rating purposes and the low temperatures for overload capability requirements. If the user intends to overload the equipment and accept a corresponding loss-of-life expectancy, this should be stated and the necessary information supplied
	For low temperature capability	For rated power capability	If preferred, curves showing how these parameters vary over the year, on a monthly basis, may be provided instead
Maximum dry-bulb temperature	°C	°C	Valve cooling, transformer and reactor design, AC and DC filter design
Maximum wet-bulb temperature	°C	°C	Evaporative cooling system design and of valve hall relative humidity
Maximum average dry-bulb temperature for a period of 24 h	°C	°C	Oil insulated transformer and <del>oil insulated</del> reactor design
Minimum average dry-bulb temperature for a period of 24 h	°C	-	Transformer, reactor and disconnect switch design and building heating needs
Minimum dry-bulb temperature	°C	-	Transformer, reactor and disconnect switch design and building heating needs, AC and DC filter design
Maximum and minimum indoor air temperatures and relative humidity	°C %	°C %	Usually determined by the valve designer for the valve hall and by the control designer for the control room
Indoor air temperatures and relative humidity during maintenance and maximum transition time after shutdown	°C %	°C %	Specified if indoor temperature extremes are too great for maintenance personnel
Maximum incident solar radiation			Building cooling, ratings of transformers, reactors, buses, etc.
Horizontal surface	W/m <sup>2</sup>		
Vertical surface	W/m <sup>2</sup>		
Wind conditions			Equipment support and building design Equipment support and building design Conductor, strain insulator and tower design
Maximum continuous velocity	m/s		
Maximum gust velocity	m/s		
Maximum velocity at a minimum temperature ..... °C	m/s		
Ice and snow covering load			Equipment and structure design, for example, disconnecter/switch, conductor, etc. Equipment and structure design, for example, disconnecter/switch, conductor, etc. Building design Equipment height above snow for safety purposes
Maximum ice thickness with no wind	mm		
Maximum ice thickness with a maximum wind speed of .....m/s	mm		
Maximum snow load	N/m <sup>2</sup>		
Maximum depth of snow	mm		
Rainfall			Building and site drainage
Annual average	mm		
Maximum in a period of 1 h	mm		
Maximum in a period of 5 min	mm		
Fog and contamination			To determine requirements for insulation and air-cooling system filter design. An estimated equivalent salt deposit density level should be specified for insulator design
Utility practice for insulator washing and greasing			
Keraunic level at the station and the first 5 km to 10 km of the line	Strokes/km <sup>2</sup> /year (substation) Strokes/100 km/year		Station lightning protection design

Parameter	Unit		Examples of use and comments
Seismic conditions Maximum horizontal acceleration frequency range of horizontal oscillations Maximum vertical acceleration frequency range of vertical oscillations Duration of seismic event	m/s <sup>2</sup> Hz m/s <sup>2</sup> Hz Cycles		Equipment, structure and foundation design
Cooling water available at the site (if used for secondary cooling)			Secondary cooling water may be used either for make-up and blow-down of evaporative coolers or for once-through cooling. Evaporative cooling towers can be a source of high humidity for the insulators and should be carefully located
Source of water			Reservoir, well, etc. If preferred, curves showing how these parameters vary over the year on a monthly basis may be provided instead.
	For low temperature capability	For rated power capability	
Maximum continuous flow rate	m <sup>3</sup> /s	m <sup>3</sup> /s	Required for cooling system design
Maximum flow rate for a period of 24 h	m <sup>3</sup> /s	m <sup>3</sup> /s	Required for cooling system design
Minimum continuous flow rate	m <sup>3</sup> /s	m <sup>3</sup> /s	Required for cooling system design
Minimum flow rate for a period of 24 h	m <sup>3</sup> /s	m <sup>3</sup> /s	Required for cooling system design
Maximum water temperature	-	°C	Required for cooling system design
Minimum water temperature	°C	-	Required for cooling system design
Maximum allowable <del>dump</del> water temperature to drain	°C	°C	Required for cooling system design
pH level			Design of water treatment plant
			Parameters apply only in the case where well water is used for evaporative cooling
Conductivity of water	μ Siemens/m		Design of water treatment plant
Type of dissolved solids			Design of water treatment plant
Quantity of dissolved solids	g/m <sup>3</sup>		Design of water treatment plant
Type of undissolved solids			Design of water treatment plant
Quantity of undissolved solids	g/m <sup>3</sup>		Design of water treatment plant
Maximum earth resistivity at the HVDC substation	Ωm		Station earth design
– Depth of water table	m		Foundation design
– Site soil conditions			Bore hole information (for example, rocks) and any special conditions, such as maximum frost depths, foundation design
– Site accessibility			To determine installation and delivery costs
– Weight and size limitations for transportation	kg, m		Equipment design – especially transformers and DC reactors
– Local profile limitations on equipment and buildings			Influence on equipment, bus and building design
– Environmental considerations			Audible noise limits, aesthetic requirements – architectural treatment, landscaping, etc.
Any special conditions not listed above, for instance, related regulations, which influence system performance should be given.			

## 6 Rated power, current and voltage

### 6.1 Rated power

#### 6.1.1 General

Rated power is the active power which the HVDC system shall be able to transmit continuously, over the range of ambient conditions specified, with all equipment in service, but without the need to utilize redundant components; the HVDC system voltage and frequency as well as the converter firing angle and the extinction angle being in their steady-state range.

Because an HVDC transmission system in general consists of three sections, i.e. the two HVDC substations and the transmission line, each of which produces losses, the point of measurement of rated power should be specified.

#### 6.1.2 Rated power of an HVDC system with transmission line

The rated power of an HVDC transmission system on a per-pole basis is defined as the product of rated direct voltage times rated direct current.

For a given direct current, transmission line losses vary with ambient conditions, which can be non-uniform along the length of the line. Therefore, it is customary to specify rated power at the rectifier DC bus. If the required transmission capability is defined at some other location, i.e. the sending-end AC bus, receiving-end AC bus, or somewhere along the HVDC transmission line, then the rated DC voltage should be defined and the rated direct current should be chosen through design optimization of the HVDC system.

Rated power and voltage at the inverter DC bus are derived values from rectifier quantities, and line losses are usually based on defined conductor parameters and uniform conductor temperature assumptions along the line.

Long distance HVDC systems may be monopolar or bipolar. Rated power should be specified on a per-pole basis stating the number of poles.

#### 6.1.3 Rated power of an HVDC back-to-back system

With system ties in a back-to-back configuration, there is no transmission line. Therefore, the rated DC voltage and current are chosen through design optimization of the HVDC system. Moreover, the rectifier and inverter are solidly connected at the DC side, operating as one unit. Rated power of such a system can, therefore, be defined as the product of rated direct voltage times the rated direct current.

#### 6.1.4 Direction of power flow

If the same power rating is required in each direction, such as with system ties for power exchange, this should be stated.

Where power flow is primarily in one direction, such as with systems fed from remote generation, rated power may be specified only for that direction to minimize the inverter cost. Then a lower inherent transmission capability should be accepted for reversal of power flow.

### 6.2 Rated current

Rated direct current is the mean value of the direct current that the system should be able to transmit continuously for all ambient conditions specified and without time limitations. The rated current should not be specified for back-to-back systems as detailed in ~~5.1.3 above~~ 4.2, unless there are specific reasons for doing so.

### 6.3 Rated voltage

The rated voltage is the mean value of the required direct voltage to transmit rated power at rated direct current. It is measured between the high-voltage bus at the line side of the DC reactor and the low-voltage bus at the HVDC substation, excluding the earth electrode line. The rated voltage is defined at nominal AC system voltage and nominal converter firing angle while operating at rated direct current.

For long distance HVDC transmission systems, the rated voltage should be specified at the sending end. If the voltage capability of the transmission line is higher than the rated voltage, then this shall be stated. The rated voltage need not be specified for back-to-back systems as detailed in 6.1.3, unless there are specific reasons for doing so.

## 7 Overload and equipment capability

### 7.1 Overload

Overload in an HVDC substation usually refers to direct current flow above its rated value. For this, consideration may be given to acceptable reduction in life expectancy of equipment (for example, due to thermal ageing), use of redundancy, and low ambient temperatures.

Overload may be specified in terms of power. Voltage regulation in the converter including the transformer normally causes a reduction of DC voltage under overload conditions and hence an increase in current somewhat more than an amount proportional to the increase in power. If rated voltage is to be maintained under overload conditions, then the following measures may be adopted, at additional cost.

- a) The converter should be designed for a higher no-load voltage. This results in a higher MVA rating if overload is required over the full range of AC bus voltage.

NOTE This ~~may not~~ cannot be necessary if overload is required only for the upper range of the steady-state AC system voltage.

- b) The voltage rating of the converter valves, which is based on transformer no-load voltage, should be increased.
- c) The on-load tap changer range should be increased if the converter firing angle is to be maintained at its nominal value. Alternatively, the converter may be designed for a higher nominal firing angle at rated power. This will increase reactive power consumption, harmonics and losses, as well as the internal stresses on valve components.

As a consequence, if rated direct voltage is to be maintained under overload conditions, oversizing of equipment will be necessary.

For a more economical design, an overcurrent rating may be specified, without regard for direct voltage regulation. Basic converter equations then permit determination of the maximum current, beyond which further increase would be offset by excessive voltage regulations.

When the converter is operated in overload it will absorb more reactive power. Unless this increased reactive power absorption can be compensated by filters/shunt capacitors, for example, from another pole, then the AC busbar voltage will reduce. When the AC system short-circuit level is low, this effect may limit the achievable overload.

The required duration of HVDC substation overloading is most often determined by AC system needs, especially following contingencies in either the AC or HVDC system.

However, some constraints should be observed for the HVDC substation equipment. Thermal time constants range from 1 s to some hours, as detailed in 7.2. Longer duration overload requirements of high magnitude may, therefore, result in an effectively increased rating of

equipment and thus impose a greater cost or a reduction of life expectancy. These factors should be weighed against system benefits when specifying overload.

EXAMPLE A practical value ~~may~~ can be a 1,2 per unit overload for 1 h which does not result in loss of life expectancy of oil-cooled transformers and reactors but ~~may~~ it is possible that it will have to be designed into thyristor valves. Also depending on the particular design, it is possible that the 1 h overload ~~may~~ will be converted to continuous if cooling redundancy is utilized. Other examples include oscillatory overloads at a frequency of up to 1 Hz for durations of several seconds, for example for power oscillation damping, and 5 s overloads to counteract temporary overvoltage or frequency changes.

The frequency and the time intervals between such overload cycles should be specified.

## 7.2 Equipment capability

### 7.2.1 General

This is defined as the ability of the HVDC substation equipment to permit transmission of greater than rated power, without loss of equipment life expectancy. It depends on operating conditions as well as on the design criteria for individual components. Implications resulting from the latter are discussed in subsequent subclauses with respect to their bearing on overload specifications.

Ambient temperature is an important factor. Power equipment is designed to perform at rated loading under the most adverse ambient conditions specified. However, these conditions normally prevail for only limited time periods. At low ambient temperatures, some margin is available for increased capability if the constraints listed in 7.2.4 can be overcome. This margin depends on the design chosen for the particular equipment and would differ for various HVDC substation components. An enveloping curve of transmission capability versus ambient temperature can be specified along with the AC system conditions to be met. This should be specified in terms of wet-bulb and dry-bulb ambient temperatures.

### 7.2.2 Converter valve capability

The thermal time constant of the thyristor heat sink combination in a thyristor valve is rather small (several seconds up to a few minutes). Overloads following continuous operation at rated current and at maximum ambient temperatures increase the thyristor junction temperature. This should be considered with respect to the specified fault suppression capability of the valve. Consequently, thyristor valve cooling should be designed so that safe operating temperatures are not exceeded even during specified overload operation.

Redundancy is provided as a general practice in the valve cooling circuit. Valves are designed such that the specified rating will be met under the most adverse ambient conditions and loss of thyristor cooling equipment redundancy. If additional capability is needed when redundant cooling is not available, this should be explicitly specified.

On the other hand, with all redundant cooling equipment in service, extra thermal capability is available. The resulting greater-than-normal current capabilities depend on the thermal design of the valve and on the cooling system.

In view of the above, converter overload specifications should state the magnitude and duration of overload, frequency of oscillatory overloads for modulation purposes, as well as the cooling equipment status to be assumed at maximum ambient temperatures.

### 7.2.3 Capability of oil-cooled transformers and reactors

The thermal time constant of the transformer or reactor windings is approximately 15 min and ranges from one to several hours for their oil circuits (if any), depending on the design.

Consequently, for short time overloads in the 5 s range, oil-cooled equipment is not the limiting factor on HVDC substation overloads. For overloads lasting longer than 1 h, it should

be specified whether loss-of-life expectancy is permitted. The expected frequency of occurrence of such overloads should be specified.

#### 7.2.4 AC harmonic filter and reactive power compensation equipment capability

HVDC substation overloads will usually generate increased harmonic currents. These in turn increase harmonic loading, losses in filters and harmonic interference levels. The specifications should state whether the interference performance under rated conditions should be met under overload conditions or to what extent degradation of performance is permitted.

Also, since overload increases the converter reactive power consumption, the specifications should state how this is to be taken into account when designing reactive power compensation equipment. If additional reactive power is drawn from the system under HVDC substation overload conditions, excessive AC bus voltage regulation and a consequent reduction in power flow may take place. For this reason, the expected AC bus voltage under overload conditions should be specified. Air-cored equipment such as air-cored reactors should be specified especially for their overload capability.

#### 7.2.5 Switchgear and buswork capability

Switchgear and buswork normally do not impose limits on HVDC substation overloads unless paralleling of converters is planned. However, special attention should be paid to the overload capabilities of current transformers and bushings.

### 8 Minimum power transfer and no-load stand-by state

#### 8.1 General

With HVDC substations there exists a minimum steady-state direct current limit. This is due to the fact that at some low level the current becomes discontinuous and is the principal criterion for a minimum power limit.

#### 8.2 Minimum current

Since the direct voltage output of an HVDC converter is made of sections of the sinusoidal bus voltage, direct current would not be a smooth or constant quantity by itself. Rather, it is made continuous by the DC reactor connected in series with the converter. Assuming a constant average direct voltage, the direct current would become discontinuous, at low power, depending on the commutating reactance of the converters, the inductance of the DC reactor, the number of valve groups in service, where series connection of groups is used, and converter firing angle, as well as the negative sequence component of the AC system voltages. Discontinuous current should be avoided in steady-state operation, unless the converter equipment is designed for this mode of operation.

Since the DC reactor inductance is usually determined by other criteria and the firing angle can be of any value, a minimum current limited shall be specified. A value of 5 % to 10 % of rated current is commonly used. This minimum direct current can further be reduced by choosing a larger value of DC reactor inductance.

#### 8.3 Reduced direct voltage operation

Under contamination conditions, often in combination with unfavourable weather conditions, operation of an overhead DC transmission line may not be possible at its rated voltage. However, the control system of the HVDC substation offers various means to achieve continuation of power flow at reduced transmission voltages.

One possibility is to move the transformer tap changer to the position resulting in the lowest AC voltage for the valves. In addition, a further decrease of transmission voltage can be achieved through operation at an increased firing angle.

This requirement could mean a special valve design and thus increase valve costs. Furthermore, since operation at large firing angles causes an increased harmonic generation and reactive power consumption, operation at reduced direct voltage then requires a reduction of the direct current if the filtering and compensation equipment is not rated for these conditions.

Other possibilities are to increase the tap changer range, or where the HVDC system is fed from an isolated power station, a reduction of AC bus voltage can also be considered.

Practical values for reduced direct voltage operation are at 70 % to 80 % of rated voltage, perhaps at reduced current. It is reasonable to expect continuous operating capability at approximately rated current at 75 % voltage with use of redundant cooling, provided that somewhat higher harmonic interference level is acceptable; this in turn depends on expected frequency and duration of such operations.

Where two series-connected 12-pulse converter units are used in each pole, one unit ~~might~~ can be switched out, resulting for example in a 50 % voltage reduction when both have the same rating, thus eliminating the necessity to operate at increased converter firing angle or reduced direct current.

To arrive at an economic design of the equipment, the AC voltage levels should be specified for expected direct voltage operations.

## **8.4 No-load stand-by state**

### **8.4.1 General**

In this mode, the HVDC substation is ready for immediate pick-up of load without the need for a lengthy start-up procedure. A definition of the status of various pieces of equipment shall be specified to determine the no-load losses of the HVDC substation, if operation in the no-load stand-by state is planned.

### **8.4.2 Converter transformers – No-load stand-by**

The converter transformers may remain energized or de-energized, depending on the user's policies with respect to losses. In the latter case, account should be taken of the time required for inrush currents to decay. Oil pumps and coolers should be in operation on a minimum level, as appropriate to the design of the transformers.

### **8.4.3 Converter valves – No-load stand-by**

The converter valves should be in the blocked condition. There will be small losses in the voltage grading circuits if the converter transformers are energized. Primary, secondary and valve hall cooling should be in operation at a sufficient level to permit immediate pick-up of load.

### **8.4.4 AC filters and reactive compensation – No-load stand-by**

The AC filters and reactive compensation may be connected or disconnected depending on reactive power control strategy within the AC system. However, for the sake of no-load loss determinations, they should be considered disconnected.

#### 8.4.5 DC reactors and DC filters – No-load stand-by

The DC reactors and DC filters should be connected. ~~DC reactors~~, Pumps and coolers for DC reactors (where fitted) should be in operation on a minimum level, as appropriate to the design of the reactors.

#### 8.4.6 Auxiliary power system – No-load stand-by

The auxiliary power system should be fully operative and ready to pick-up rated load, for example, all station service transformers energized, battery chargers in operation, ~~etc.~~

#### 8.4.7 Control and protection – No-load stand-by

All control and protection circuits should be operative.

### 9 AC system

#### 9.1 General

The following information in Clause 9 should be specified for AC systems at both ends for each stage of development as well as for expected future changes. Different values may be specified for performance and rating purposes.

The arrangement of the AC switchgear to which the converter units and filters are to be connected, including AC lines, should be described. This should also be done for the planned operating schemes of the switchyard.

Specific data should be made available for generators in the close vicinity, particularly if the major load for the generators is served through the rectifier. Often all data pertinent to load flow and short-circuit studies are also needed.

#### 9.2 AC voltage

##### 9.2.1 Rated AC voltage

Rated AC voltage is the RMS phase-to-phase fundamental frequency voltage for which the system is designed and to which certain characteristics of the AC equipment are related, such as AC switchgear, AC filters, reactive power compensation equipment, primary windings of converter transformers, etc.

Rated voltage may be used to define the rated power of such AC equipment.

##### 9.2.2 Steady-state voltage range

###### 9.2.2.1 General

The steady-state voltage range is the range over which the HVDC system should be able to transmit rated power and over which all performance requirements are to be met, unless stated otherwise.

Any special performance requirements beyond the limits of the steady-state range should be specified. These may affect the design of main equipment, converter transformers, filters, auxiliary equipment, etc.

###### 9.2.2.2 Short-term voltage range

There may be situations under which the voltage exceeds the normal steady-state operating range but the HVDC system may be required to remain in operation. Under these conditions the HVDC system may be designed to operate in a manner whereby no equipment should be

at risk of damage, but the performance limits of the system may be acceptably degraded (for harmonics, losses, etc.).

The acceptable degraded performance limits should be specified since these will have an effect upon the ratings of equipment.

The HVDC control system may even be specified to assist in the restoration of the voltage to within the normal operating range (through either HVDC control action or addition/removal of filters and reactors) if this is appropriate.

### 9.2.2.3 Voltage variation during emergency

Dynamic overvoltages could determine ratings and protection strategies.

Under extreme circumstances, the AC voltage may exceed even the short-term range, in which case it may be desirable to remove the HVDC system from operation in order to protect the equipment. Alternatively, it may be possible to rate the HVDC converter equipment to operate within these limits, although this will probably require higher cost equipment and degraded performance.

The HVDC control system may even be specified to assist in the restoration of the voltage to within the normal operating range (through either HVDC control action or addition/removal of filters and reactors), if this is appropriate.

### 9.2.3 Negative sequence voltage

The negative sequence component of AC voltage calculated according to the method of symmetrical components is that balanced set of three-phase voltages whose maxima occur in the opposite order to that of the positive sequence voltages. It is generally expressed as a percentage of the rated voltage.

Although it is difficult to obtain an actual value for this parameter, the maximum to be used in determination of non-characteristic harmonics of the current on the AC side and the non-characteristic harmonic voltages on the DC side should be specified. These harmonic currents and voltages are respectively used for the design of the AC filter, DC filter and DC reactor (see Clauses ~~16~~, 17, 18, and 21).

## 9.3 Frequency

### 9.3.1 Rated frequency

The frequency of an AC system should be specified to give the basis of rating of the AC equipment, converter transformer, etc., as well as converter bridges and control.

The design of the DC filters is also influenced by the AC system frequency.

### 9.3.2 Steady-state frequency range

Steady-state frequency range is the range, in conjunction with the AC voltage steady-state range, over which the rated power may be transmitted and all performance requirements are to be met.

### 9.3.3 Short-term frequency variation

Limits and duration of short-term frequency excursions for which system performance is required should be specified. This can be a sensitive parameter for AC and DC filter design. Filtering performance during such variations may be specified.

#### 9.3.4 Frequency variation during emergency

During an emergency the AC system frequency may reach extreme values for limited periods. These values and their expected durations should be specified. In this condition, the equipment should remain in service without damage, but should not be required to meet the performance specified. For excursions beyond the specified operating frequency limits, it may be permissible to automatically disconnect the equipment.

#### 9.4 System impedance at fundamental frequency

For the purpose of analysis of commutation conditions in the converter, the system impedance at fundamental frequency should be stated. Maximum and minimum values of the subtransient impedance at the AC bus, without any filter or compensating equipment, are needed for such analysis.

Subtransient impedance is the positive sequence impedance of the AC system as determined by the subtransient reactance of synchronous machines, leakage reactance of induction machines and positive sequence impedance of connecting lines.

Additionally, a detailed AC system impedance or a suitable equivalent should be specified, in order to optimize the DC control.

#### 9.5 System impedance at harmonic frequencies

System impedance at all harmonic frequencies from the 2nd up to the 50th is needed for AC filter design and performance calculations.

This impedance may be calculated using the parameters of the lines, transformers and generators up to five to eight HVDC substation buses. However, this impedance may change considerably under different load conditions and extension stages of the system. Therefore, it is usually more convenient to use an  $R$ - $X$  diagram and to plot the envelope of the locus of the system harmonic impedance under expected system conditions. The values of  $R_{\min}$  and  $X_{\min}$  should be included in the diagram.

In practice, this diagram may take various forms such as a circular plot, limited by constant  $R/X$  ratio or ~~the combination of both~~ a series of polygons defining ranges of harmonic impedance for each frequency. Further guidance can be found in IEC TR 62001 (all parts).

#### 9.6 Positive and zero-sequence surge impedance

The positive and zero-sequence surge impedance is needed for all AC lines going into the station for evaluation of interference from converters in the carrier frequency band and for design of appropriate filters.

#### 9.7 Other sources of harmonics

Other sources of harmonics electrically close to the HVDC substation should be identified. Their influence should be taken into account in AC filter and capacitor bank ratings. Generated harmonic currents should be stated for the static reactive power compensators connected to the converter substation bus or to nearby AC substations.

#### 9.8 Subsynchronous torsional interaction (SSTI)

If subsynchronous torsional interaction (SSTI) problems are expected, all related information from the pertinent studies should be provided (see also ~~Clause 9~~ 13.2.4).

## 10 Reactive power

### 10.1 General

Clause 10 identifies the considerations relevant to reactive power.

### 10.2 Conventional HVDC systems

Line commutation of converter bridges, as used in conventional HVDC systems, requires a consumption of reactive power in both rectifier and inverter operation. At full load, this consumption represents 50 % to 60 % of rated power for commonly used values of transformer impedance and firing angle or extinction angle.

At partial load reactive power consumption can be varied according to AC system requirements by using an appropriate control strategy. A control strategy which is often adopted is to maintain the delay angle  $\alpha$  in the rectifier, or the extinction angle  $\gamma$  in the inverter, within narrow limits by means of the tap changer of the converter transformer. Under this strategy, the variation of reactive power versus real power is shown in Figure 19, curve 1, for constant direct voltage and constant extinction angle  $\gamma$ . As an alternative, a linear variation may be obtained, as shown on Figure 19, curve 2, which involves maintaining constant no-load direct voltage  $U_{d0}$  by means of an increase of the delay angle  $\alpha$  in the rectifier and extinction angle  $\gamma$  in the inverter, when the load is reduced.

If the direct current is kept constant and partial load is achieved by increasing the delay angle and thus reducing the direct voltage, reactive power consumption is increased at partial load according to curve 3 in Figure 19. Any characteristic between curves 1 and 3 can be implemented to meet specific AC system requirements.

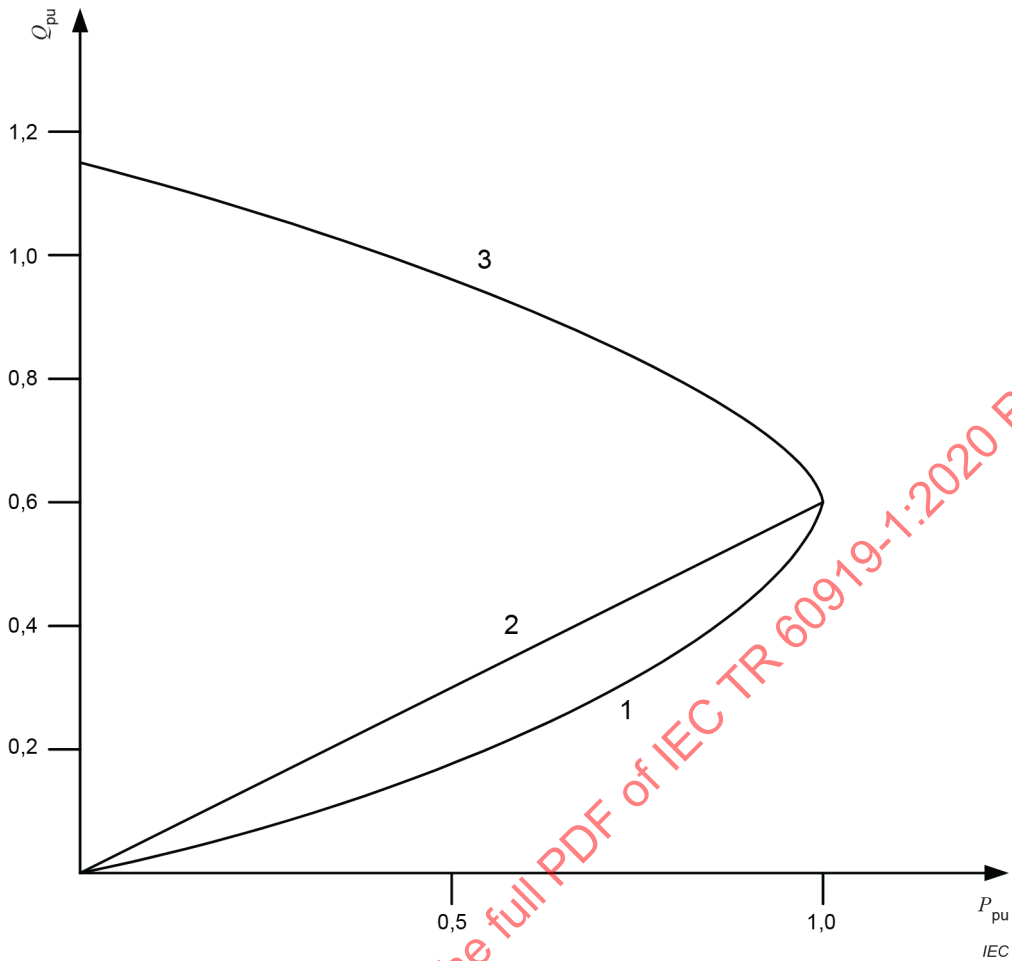

**Key**

- 1 Constant DC voltage – Constant  $\gamma$
- 2 Constant DC voltage – Constant  $U_{d0}$
- 3 Constant DC current

**Figure 19 – Variations of reactive power  $Q$  with active power  $P$  of an HVDC converter**

Combined changes of the valve firing angle and the load tap changer of the converter transformer may be used to control the reactive power demand of an HVDC substation. However, since this requires an increase of the firing angle, it leads to an increased generation of harmonic currents and voltages and increased losses in the damping circuits of the valves.

Looked at another way, filtering of AC current is obtained through harmonic filters, which also generate reactive power. However, the fundamental frequency reactive power generated by the filters as determined by the AC filtering requirements at full load is generally less than the reactive power consumption of the converter bridges. Therefore, additional capacitor banks are usually provided to meet the total reactive power demand of the converter.

The net reactive power of the converters and filters, taking into account filtering consideration, may be controlled within certain limits, by switching of capacitor banks and also part of the filter banks, if needed.

To define a suitable strategy of reactive power control, the aspects described in 10.4 to 10.7 should be specified.

### 10.3 Series capacitor compensated HVDC schemes

Reactive power requirements of conventional HVDC schemes are addressed by adding shunt devices such as shunt capacitors and filters.

Conversely, both CCC and CSCC treat this differently, as instead of connecting capacitor banks in parallel to the converter bus, they are inserted between the transformers and valves (CCC) or between the transformers and the AC network (CSCC). By these configurations, the voltage across the series capacitor adds to the commutation voltage resulting in a wide range of trigger delay angle ( $\alpha$ ) and extinction angle ( $\gamma$ ). This brings about less overlap angle ( $\mu$ ) and thus less reactive power consumption. AC filters are required only for harmonic elimination and not for reactive power support. This reduces the MVAR rating of the filter to small values. Unlike the conventional case, neither the CCC nor CSCC configuration requires filter-bank switching for variations in the load over the full range of operation.

### 10.4 Converter reactive power consumption

The reactive power consumption should be determined for the different operating conditions for the rectifier and inverter under partial load, full load and overload conditions. The method of calculation and the parameters used in the calculations should also be specified.

The operating conditions to be considered include: direction of power flow, monopolar earth return, monopolar metallic return, bipolar and reduced direct voltage operation over the specified range of steady-state AC bus voltage.

Also at minimum power transfer with a minimum number of AC filters connected, the ability of the converter valves to operate with increased firing angle/extinction angle can be utilized to minimize the reactive power flow to the AC systems.

### 10.5 Reactive power balance with the AC system

To determine the reactive power sources to be installed, an overall balance of reactive power has to be known. To determine the appropriate reactive power, balance load flow studies may need to be performed. Apart from the reactive power needs of the converters, consideration should be given to the following:

- the power factor range to be maintained in the AC lines for all operating conditions;
- the operating voltage ranges under light and peak load conditions of the AC system;
- reactive power available from nearby generators;
- redundancy requirements.

If the rectifier is directly connected to a power station, the following points should also be considered:

- generator capability over the maximum and minimum permissible operating voltage range;
- tap changer range available in the step-up transformer, and the tap to be used for each development stage;
- reactive power requirement of other loads;
- minimum permissible active power for the generators;
- self-excitation limit of the generators;
- minimum number of generators to be connected.

### 10.6 Reactive power supply

The sources of reactive power supply to meet the set of requirements should include the most economical combination of filters, shunt capacitors, shunt reactors, series capacitors, synchronous and static reactive power compensators that meets the performance criteria. Much of the reactive power should be supplied in the form of filters to meet the harmonic

performance. Under light load conditions, the minimum size of the available filter bank connected ~~may can~~ lead to surplus reactive power and consequently excessive steady-state voltage. This ~~may can~~ require provision of shunt reactors or use of converter capability to consume greater reactive power.

Shunt capacitor banks are the most economical source for the required remaining reactive power. Synchronous and static reactive power compensators should be considered only if there is a dynamic voltage and/or stability problem (see Clause 9). There ~~may can~~ be additional requirements associated with the adjacent AC systems.

### 10.7 Maximum size of switchable VAR banks

Filters and capacitor banks may be divided into small switchable banks. The size of switchable banks depends on:

- a) voltage control requirements over the whole operating range from no load to full load and overload;
- b) acceptable regulation step per switching operation. It should be noted that the regulating effect from switching reactive power banks can be modulated with the help of converter control;
- c) frequency of switching.

When considering combinations of filters and shunt capacitors with synchronous compensators, the filters and shunt capacitors should be limited in size to avoid self-excitation of the synchronous machines.

## 11 HVDC transmission line, earth electrode line and earth electrode

### 11.1 General

Clause 11 identifies those characteristics of the HVDC transmission line, the earth electrode and the earth electrode line that are relevant to the specification of the steady-state performance of the converter, including power line carrier performance and design requirements. It does not provide the information that should be specified for the design of the HVDC transmission line, earth electrode lines or earth electrodes themselves.

Key performance specification data for the HVDC transmission line, the earth electrode line and the earth electrode should be determined in advance.

### 11.2 Overhead line(s)

#### 11.2.1 General

The total length of the line should be given, including details concerning any overhead and cable sections. Details should be provided of any right-of-way joint uses. Particulars of all crossings and parallelisms need to be given to enable assessment of possible electrical interactions and interference. If the exact length is not known, the expected range for this length should be stated.

For bipole and multi-pole lines, information on the spacings between poles and bipoles along the complete route will be needed.

#### 11.2.2 Electrical parameters

The electrical parameters are the following:

- 1) resistance – maximum positive and zero-sequence DC values at minimum current, rated current, maximum overload current with due consideration of the ambient conditions (temperature, radiation, wind velocity, etc.) prevailing during the load condition considered.

Curve of frequency dependence up to ~~100 Hz~~ the 49<sup>th</sup> harmonic of the fundamental frequency for rated current;

- 2) capacitance – positive and zero-sequence capacitance ( $C_1$  and  $C_0$ );
- 3) inductance – positive and zero-sequence inductance ( $L_1$  and  $L_0$ ), curve of frequency dependence up to ~~100 kHz~~ the 49<sup>th</sup> harmonic of the fundamental frequency for these.

If the information in 1) to 3) above is not available, as an alternative, the necessary data to enable its calculation could be given. To calculate these parameters, the following data will be required:

- a) conductor size, type, geometry (including the shield wire);
- b) tower outlines, spacing and sag profiles;
- c) soil resistivity along the route;
- d) tower footing resistance;
- e) the worst-case maximum conductor surface gradients to permit calculation of corona effects, for example, if a carrier is to be used;
- f) critical impulse flashover level of insulation.

It is strongly recommended that the HVDC transmission line be adequately shielded from direct lightning strokes for the first 10 km from the HVDC substation and for the HVDC transmission line tower footing resistance to be sufficiently low, for example, less than 10  $\Omega$  up to 25  $\Omega$ .

As a third alternative, in place of sequence components, the information could be provided in the form of self- and mutual impedance between conductors and earth.

### 11.3 Cable line(s)

#### 11.3.1 General

Length of sections or total length should be specified as appropriate. Any restrictions on service conditions imposed by the cable supplier should be stated.

Examples of such restrictions might include:

- a) limitations on polarity reversal;
- b) limitations on discharge rate;
- c) limiting voltage and current ripple level;
- d) limitations on overvoltages and overcurrents.

#### 11.3.2 Electrical parameters

The electrical parameters are the following:

- 1) DC resistance of conductor, maximum value at rated current and at maximum overload current, minimum value at minimum current;
- 2) conductor resistance frequency dependence up to 5 kHz;
- 3) cable sheath resistance and frequency dependence up to 5 kHz;
- 4) inductance and frequency dependence up to 20 kHz;
- 5) capacitance of conductor to sheath;
- 6) capacitance of sheath to earth (armour);
- 7) surge impedance of cable conductor to sheath;
- 8) attenuation characteristics up to 50 kHz.

## 11.4 Earth electrode line

To evaluate possible transformer saturation effects due to direct current flowing via the station earthing system and earthed neutrals, the earth electrode line length, as well as the length of any part of it which is on the HVDC transmission line towers should be specified.

The earth electrode line resistance – maximum value and ambient temperature assumptions – should be stated.

## 11.5 Earth electrode

The maximum resistance of the earth electrode relative to the remote earth should be indicated. It should be noted that this resistance may increase with time and environmental and/or load conditions.

## 12 Reliability

### 12.1 General

The reliability of an HVDC system is the ability to transmit a defined energy within a defined time under specified system and environmental conditions.

The purpose and scope of Clause 12 is for writing specifications and evaluating reliability. Clause 12 defines reliability calculations during the acceptance period of an HVDC system. Please refer to Annex A for more information on factors affecting reliability and availability of converter stations. Reference is made to ~~the CIGRE Brochure 346~~ IEC TR 62672 which deals with a reporting procedure of specific failures and overall availability of HVDC systems in operation. Although the scope of ~~the CIGRE Brochure 346 is different~~ IEC TR 62672 differs from that of this document, the basic terms used and their definitions are common to both documents.

Terms and definitions applicable to the reliability of HVDC systems are given below.

### 12.2 Outage

#### 12.2.1 General

An outage of the HVDC system is an event when the transmission capability falls to a level below the maximum rated power. This may be caused by defects of components of parts of the equipment, human errors, switching-out of equipment for maintenance and repair, switching-out caused by an operation of protection equipment, external fault, etc. (see 12.3.3). Consideration should be given to defining which of these or other causes should be included in the availability and annual number of forced outages. An outage will be included in the calculations either as a scheduled outage or a forced outage (12.2.2 and 12.2.3, respectively).

#### 12.2.2 Scheduled outage

A scheduled outage is an outage where the transmission capability falls below the rated power level, and is planned in advance to allow part or all of the HVDC system to be taken out of service for a scheduled maintenance period or for equipment repair.

#### 12.2.3 Forced outage

A forced outage is an unscheduled outage, which is initiated either by automated protection equipment action or through operator intervention (i.e. taking a decision to shut down all or part of the HVDC system in a situation where continued operation may cause damage to personnel or equipment and the shutdown cannot be deferred until the next scheduled outage).

## 12.3 Capacity

### 12.3.1 General

The capacity terms defined below are normally defined at one point in the HVDC system (such as the sending-end AC terminals, the receiving-end AC terminals, or the sending-end DC terminals). In cases where each of the HVDC converter terminals are under separate ownership, it may be appropriate to define the rating of each station individually.

### 12.3.2 Maximum continuous capacity $P_m$

This is defined as the maximum power value (in MW) for which the HVDC system is rated for continuous operation, excluding any additional capacity available through the presence of redundant equipment.

### 12.3.3 Outage capacity $P_o$

For the duration of the outage, the power available is reduced from the maximum rating by an amount (in MW) called the outage capacity  $P_o$ .

### 12.3.4 Outage derating factor (ODF)

The outage derating factor is defined as the ratio of the outage capacity  $P_o$  to the maximum capacity  $P_m$ :

Error! Bookmark not defined. 
$$ODF = \frac{P_o}{P_m} \quad (1)$$

## 12.4 Outage duration terms

### 12.4.1 Actual outage duration (AOD)

The actual outage duration is defined as the time elapsed in decimal hours between the start and the end of the outage. The outage is typically started when a switching event takes place to interrupt the main circuit power flow, or to initiate the reduction to the outage power level. The outage is typically completed when a switching event takes place to restore the equipment to a state where it is ready for operation, although not necessarily put into operation, i.e. the equipment is made available for service operation.

The actual outage durations may be segregated into forced and scheduled, such that the figure value of AOD for each outage becomes either actual forced outage duration (AFOD) or actual scheduled outage duration (ASOD).

### 12.4.2 Equivalent outage duration (EOD)

To take into account the partial loss of capacity, the equivalent outage duration is defined as the actual outage duration multiplied by the outage derating factor

$$EOD = AOD \times ODF \quad (2)$$

Similarly to the creation of forced and scheduled actual outage durations, it is possible to segregate the equivalent outage durations into forced and scheduled to give equivalent forced outage duration (EFOD) and equivalent scheduled outage duration (ESOD).

### 12.4.3 Period hours (PH)

The period hours is the total number of hours in the period covered by the analysis and is typically one year or 8 760 h.

#### 12.4.4 Actual outage hours (AOH)

The actual outage hours are the sum of the individual actual outage durations for the period of the analysis.

$$AOH = \sum AOD \quad (3)$$

It is possible to subdivide the AOH ~~figure~~ value into forced and scheduled outage hours, by summing the AFOD and ASOD values rather than the summation of the AOD values.

#### 12.4.5 Equivalent outage hours (EOH)

This is defined as the sum of the individual equivalent outage durations within the period of the analysis.

$$EOH = \sum EOD \quad (4)$$

It is possible to subdivide the EOH ~~figure~~ value into forced and scheduled outage hours by summing the EFOD and ESOD values, rather than the summation of the EOD values.

### 12.5 Energy unavailability (EU)

#### 12.5.1 General

This is a measure of energy which could not have been transmitted due to outages.

Energy unavailability is determined from the equivalent outage hours ~~figure~~ value, as follows:

$$EU \% = \left( \frac{EOH}{PH} \right) \times 100 \quad (5)$$

It is usually expressed as a percentage ~~values~~.

For reliability studies, it is essential to distinguish between the effects of line faults on monopolar and on multipolar (bipolar) transmission systems.

In a monopolar system, a line fault causes a complete collapse of the transmission. In a bipolar system, for most cases, a line fault only affects one pole of the transmission system, so that line faults would, in general, reduce energy transmission by 50 %. However, if the remaining transmission line pole is designed for some degree of overcurrent capability and if the converter groups on the HVDC substation can be connected in parallel, then more than 50 % of the energy may be transmitted after the necessary switching for paralleling the converters has been performed.

In the case of a fault in a converter unit, the affected unit may have to be switched out. The percentage loss of transmission capacity is given by the number of converter groups taken out of service related to the total number of converter units.

There may be other contingencies, such as partial loss of filters, faulted earth electrode line, etc. Their impact on availability should be defined.

### 12.5.2 Forced energy unavailability (FEU)

There is a measure of the energy which could not have been transmitted due to forced outages:

$$FEU \% = \left( \frac{EFOH}{PH} \right) \times 100 \quad (6)$$

where *EFOH* means equivalent forced outage hours.

### 12.5.3 Scheduled energy unavailability (SEU)

This is a measure of the energy which could not have been transmitted due to scheduled outages:

$$SEU \% = \left( \frac{ESOH}{PH} \right) \times 100 \quad (7)$$

where *ESOH* means equivalent scheduled outage hours.

## 12.6 Energy availability (EA)

This is a measure of the energy which could have been transmitted by an HVDC system:

$$EA \% = 100 - EU \% \quad (8)$$

## 12.7 Maximum permitted number of forced outages

Not all the forced outages are to be counted. The maximum permitted number of such forced outages for the period hours PH should be defined.

## 12.8 Statistical probability of outages

### 12.8.1 Component faults

In addition to the availability of the overall system, the reliability of some individual components may also be considered.

Every component in the system can be characterized by its failure rate  $\lambda$ . It is well to distinguish between statistical failures (random outages) and failures at the end of the component lifetime (for example, outages of luminescent diodes because of ageing). To stock spare parts, good practice differentiates between these two kinds of failures, since at the end of their lifetime all of the concerned components should be replaced.

### 12.8.2 External faults

The expected number of AC system faults and their duration, which may detrimentally influence the behaviour of an HVDC system, should be stated. The probability of the occurrence of such faults should be considered when stating the permitted number of HVDC system forced outages.

## 13 HVDC control

### 13.1 Control objectives

The advantages of an HVDC system very much depend on the utilization of its controllability in ensuring maximum flexibility, reliability and adaptability for different system requirements.

The control system should be able to maintain stable operation of converters and normal power transmission of the HVDC system within the specified range of AC voltage and frequency. The objective of an HVDC control system should be to provide efficient operation and maximum flexibility of power control in magnitude, rate of change and direction without compromising the safety of the equipment, while maintaining the maximum independence of each pole. The control system should be suitable for high-speed control in such a way that it can effectively respond to disturbances in the AC and HVDC systems. It is recognized that long-distance transmission requires a high-speed telecommunication system for the most effective operation. However, the HVDC system should be operable without telecommunication, and, for this case, the performance should be maximized to the extent possible.

The control system should be adaptable for:

- 1) control of the reactive power exchange with the AC system including reduced or increased reactive power consumption;
- 2) AC voltage control;
- 3) frequency control;
- 4) active power modulation;
- 5) combined active and reactive power modulation;
- 6) subsynchronous torsional interaction damping;
- 7) remote operation;
- 8) coordinated control of converters among two terminals.

### 13.2 Control structure

#### 13.2.1 General

The various control circuits of an HVDC substation are generally structured in a hierarchical manner. The main control functions are dispersed to a lower level as far as possible to improve the system reliability and availability. They normally operate fully automatically. For long-distance HVDC transmission systems, a telecommunication link is needed to coordinate between the rectifier and the inverter. The various levels are described subsequently, starting with the lowest level (Figure 20).

#### 13.2.2 Converter unit firing control

The converter unit firing control is essentially an open loop control. Its outputs are the firing pulses to the individual valves in a 12-pulse converter unit. These are synchronized to the AC system voltage. The input is the delay angle  $\alpha$  or the trigger advance angle  $\beta$ , as provided by the next higher level.

There are mainly two types of converter unit firing control principles which have been used for HVDC:

- equal delay angle control;
- equidistant firing control.

Equal delay angle control is a method of timing the valve control pulses so that the delay angles of the valves in the converter unit are essentially equal, regardless of unbalances in the AC system voltage.

Equidistant firing control is a method of timing the valve control pulses in such a way that they are essentially equidistant in time, regardless of unbalances or distortion in the AC system voltage.

The function requirements of the converter unit firing control are:

- a) operation down to low values (i.e. fewer than 3) of the ratio between the short-circuit capacity of the AC network and the transmitted DC power;
- b) that the permitted deviation from equidistant firing should be  $\pm\Delta^\circ$ , i.e. each firing during conditions specified shall occur  $30 \pm \Delta^\circ$  after the preceding firing (for a 12-pulse converter unit). It should be noted that the conditions are different with regard to a reasonable value for  $\Delta^\circ$  for different converter modes of operation, i.e. operation with minimum  $\alpha$ , current control or minimum extinction angle control.

Deviation from equidistant firing gives rise to non-characteristic harmonics transferred to the AC network as well as to the HVDC transmission line. A typical permitted maximum value of  $\Delta^\circ$  is  $0,2^\circ$ , assuming that the AC system voltage and impedances are balanced.

### 13.2.3 Pole control

The pole control provides the reference values per pole for all series-connected converter units, if any.

Pole control is a closed loop control and includes the basic control functions that are required for stable operation of the HVDC system, such as current control, voltage control, extinction angle control, power control, tap changer control. All these control functions have a reference value and an actual value. Some of these reference values may be provided by the pole control (for example, the current reference value, which is calculated out of the requested transmission power), others can be provided by the operator (for example, DC voltage, DC power).

Generally, each substation pole is provided with a pole control (Figure 20) that controls the DC voltage output of the converter by determining the firing instant of the valves. The pole control senses the difference between the order and the response and adjusts the converter DC output voltage accordingly. If the current order in the rectifier is larger than the current response, the firing control increases the direct voltage by decreasing the delay angle, thus increasing the direct current. The direct voltage is increased until the current response equals the current order or the maximum voltage is reached when firing at minimum delay angle, (minimum voltage ~~across~~ between the terminals of the valve ~~capable to~~ at which the valve will fire ~~it~~ correctly). On the other hand, if the current response is larger than the current order, the direct voltage is correspondingly decreased. The decreasing action is limited when the converter operation has been transferred from rectification to inversion and firing given the least permitted extinction angle (to ensure safe valve recovery).

The typical voltage current characteristics of a rectifier and an inverter are shown in Figure 21 a) and Figure 21 b).

Normally, the maximum voltage limit in the inverter is lower than that of the rectifier, and the current will be controlled by the rectifier. That is, the inverter will maintain the voltage, and the rectifier will adjust its voltage until the current becomes equal to the order input, and a stable working point A is established (Figure 21 a).

If the inverter voltage limit is larger than the rectifier voltage limit, the inverter controls the current and the rectifier maintains a maximum voltage. As Figure 21 a) and Figure 21 b) show

the control characteristic in a simplified form, typical examples of more detailed characteristics are shown in Figure 21 c).

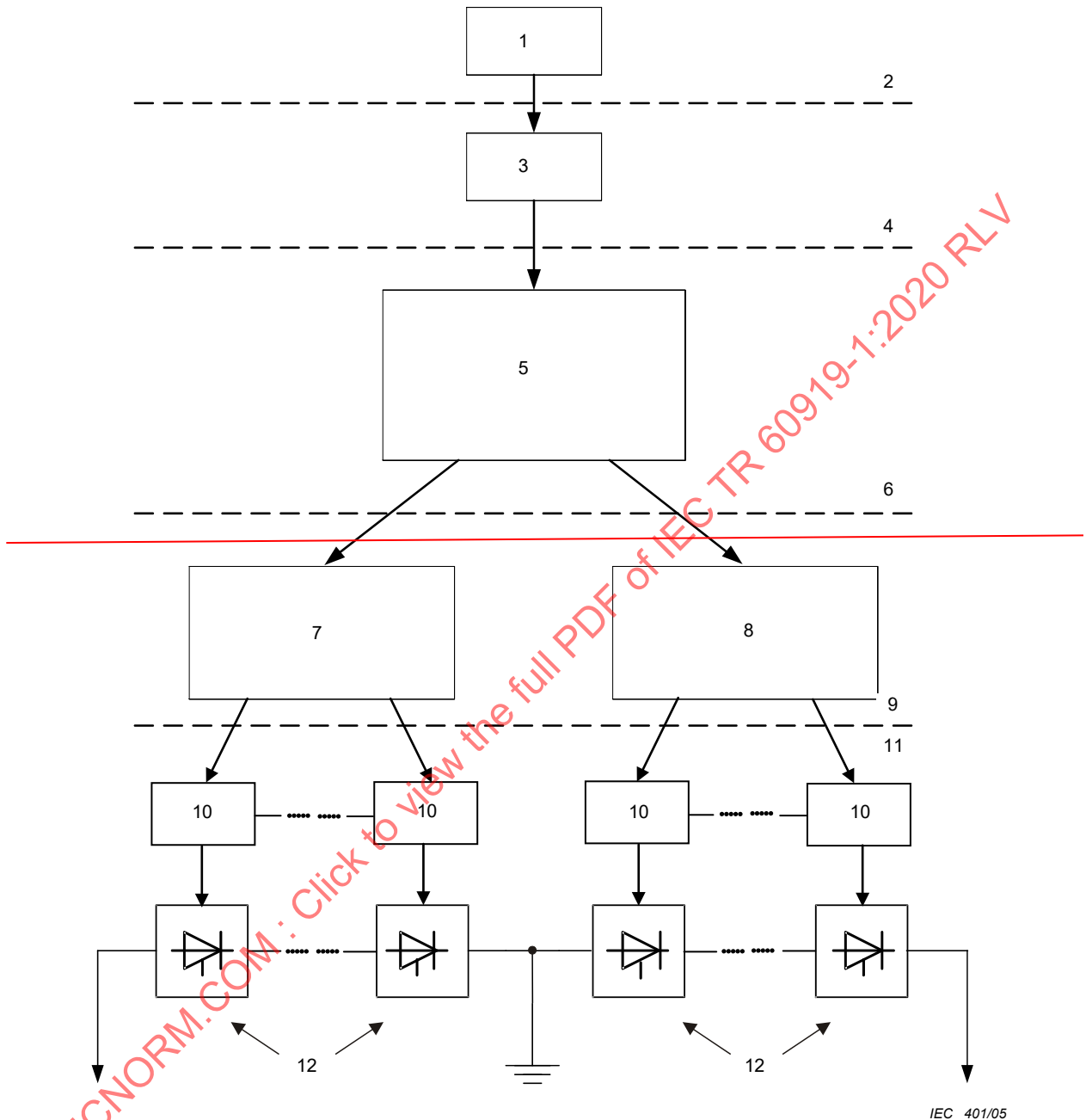

IEC 401/05

**Key**

- 1 — Integrated a.c./d.c. system control
- 2 — AC/d.c. system level
- 3 — HVDC system/master control
- 4 — Area level (or local substation level)
- 5 — Bipole/substation control (substation sequencing, substation power control, substation power capability calculator, reactive power control, a.c. voltage control)
- 6 — HVDC substation (bipole level)
- 7 — Pole 1 (d.c. protection, pole sequencing, pole power control, tap-changer control, pole power capability calculator)
- 8 — Pole 2 (d.c. protection, pole sequencing, pole power control, tap-changer control, pole power capability calculator)
- 9 — HVDC substation (pole level)
- 10 — Valve base electronics (thyristor firing control, thyristor status reporting, thyristor protection)
- 11 — Converter unit level
- 12 — Converters

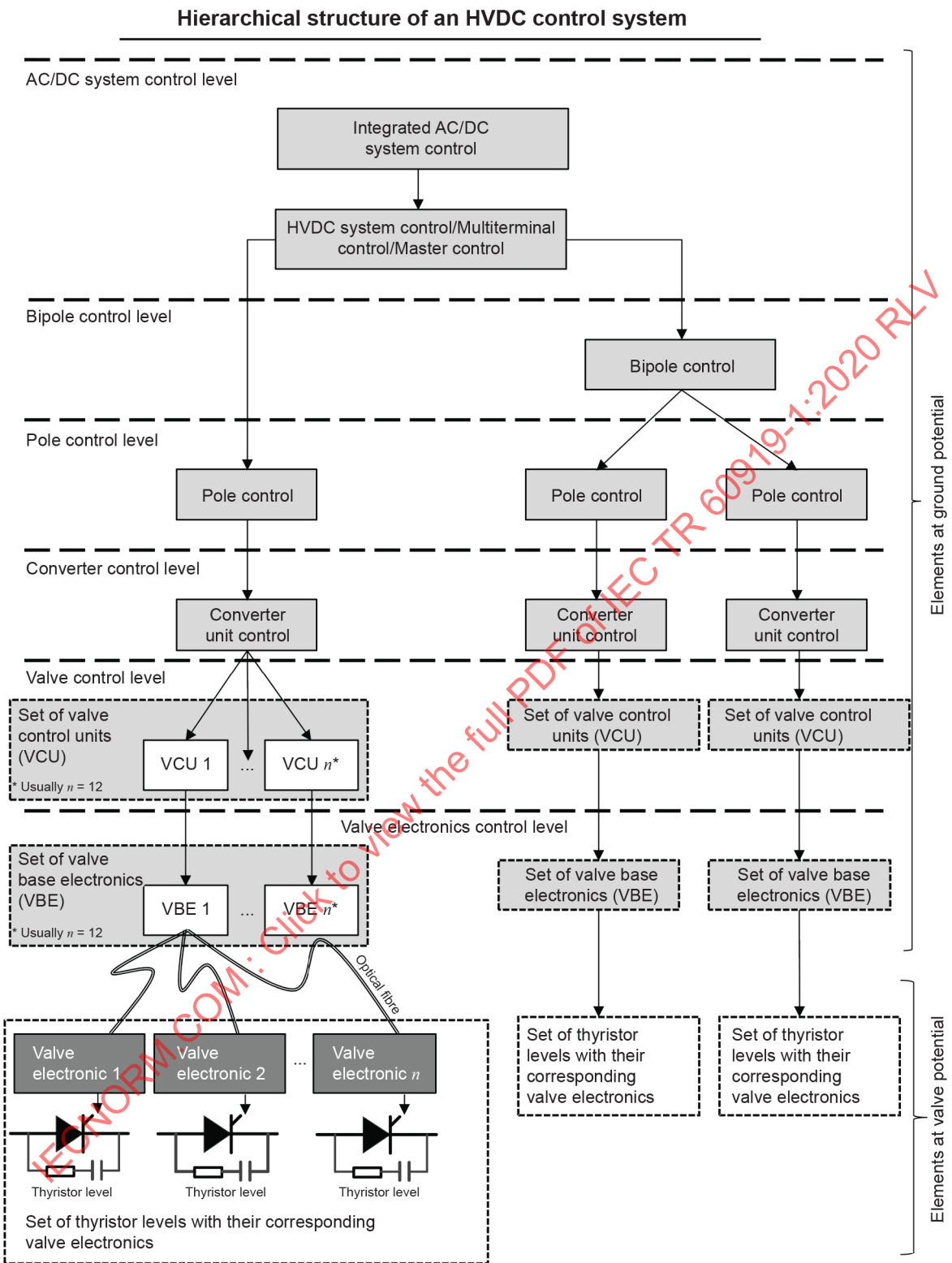

IEC

**Figure 20 – Control hierarchy for HVDC/UHVDC system**

As noted, the rectifier usually controls the current and the inverter determines the voltage. The inverter current order equals the rectifier current order less the "current margin" ( $\Delta I = I_R - I_I$ ) (Figure 21 a). The inverter is forced to fire at the lowest allowed trigger advance angle  $\beta$  keeping the extinction angle constant at  $\gamma_{min}$ , and, accordingly, the inverter establishes the voltage on the HVDC transmission line.

For long-distance transmission, the DC voltage at the inverter is usually kept constant by appropriate control of the inverter transformer tap changers. Alternatively, the inverter establishes constant DC voltage by controlling the extinction angle.

For converters connected in series, voltage balance control of valve groups should be applied.

In other systems, the inverter is controlled in such a way as to keep the HVDC transmission line voltage constant. In this case, the transformer tap changer is used to keep the extinction angle  $\gamma$  within a certain range.

The delay angle in the rectifier is kept within a narrow band (nominal  $\alpha \pm \Delta\alpha$ ) by means of adjustment of the tap changers of the converter transformers. DC voltage variation by changing the delay angle by  $\Delta\alpha$  normally corresponds to one tap-changer step. Alternatively, the converter no-load direct voltage may be kept constant by means of adjustment of the tap changers.

Reduced DC voltage may be needed, for example, at times of reduced voltage withstand capability of the HVDC transmission line. This can be accomplished in the rectifier as well as in the inverter by tap change in the converter transformer, by adjustment of the delay angle or by switching off one series connected converter groups, if any.

#### 13.2.4 HVDC substation control

The HVDC substation control is normally implemented as a closed loop control system. One major design criterion for HVDC systems is normally to minimize the equipment at the station level as much as possible, in order to minimize the impact on the bipole in case of a fault at that level. Referring to station level functions, these could also be realized within pole level hardware, and may include:

- a) coordination of current orders between the two ends via the telecommunication link, most likely on a per-pole basis;
- b) power control;
- c) coordination between the poles of an HVDC substation (if there is more than one pole);
- d) additional controls such as frequency control, run up/runback control, power oscillation damping, etc.;
- e) more sophisticated control strategies.

Examples of the more sophisticated control strategies are described below.

The reactive power consumption of an HVDC substation is dependent upon the firing angle and the direct current flowing. Thus the DC link can be used for control of reactive power or for voltage control in the AC network.

The HVDC substation control can be coordinated with control external to the HVDC substation, for example, the turbine governor of a generator station. The HVDC substation can also be provided with controls to avoid subsynchronous torsional interaction (SSTI) of a turbine-generator.

Pole current balance control can be specified to minimize earth electrode line current (equal to the unbalance current between two poles of a bipolar earth return HVDC system), to avoid corrosion problems from earth current flow through underground structures. A typical unbalance current limit between the two poles of a bipolar system without balance control might be 3 % of rated current.

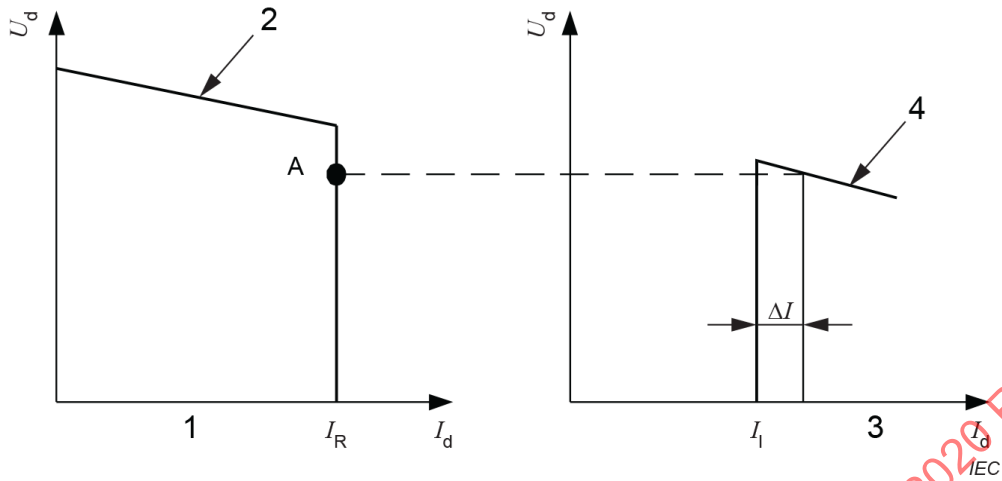

a) Normal operation, rectifier controls the current

**Key**

- |   |   |   |  |
|---|---|---|--|
| 1 | Rectifier                                   | 3 | Inverter                                   |
| 2 | Rectifier firing at $\alpha = \alpha_{min}$ | 4 | Inverter firing at $\gamma = \gamma_{min}$ |

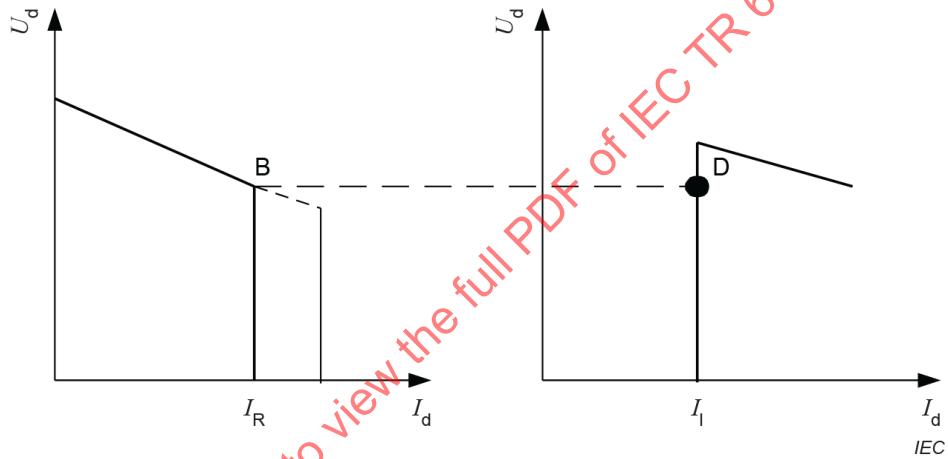

b) Inverter controls the current

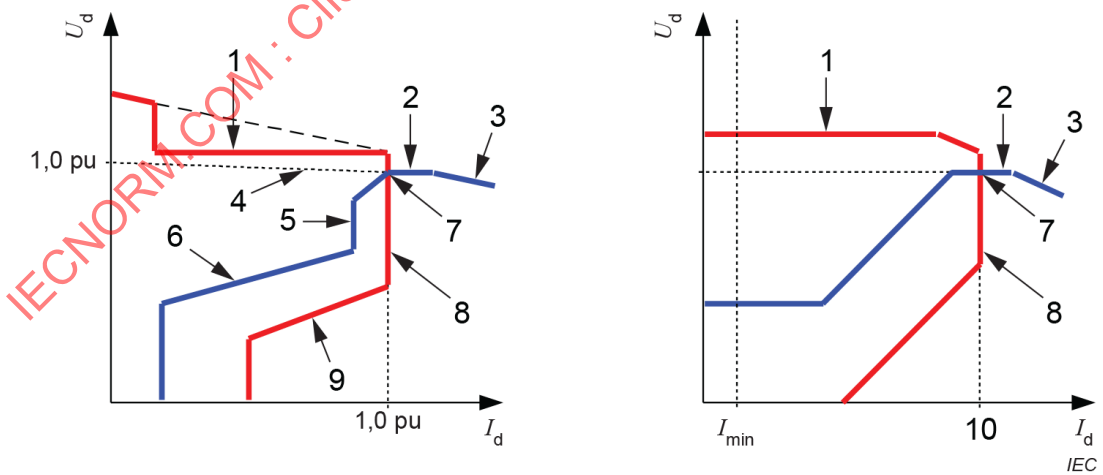

c) Examples of HVDC control characteristic

**Key**

- |   |  |    |  |
|---|--|----|--|
| 1 | Rectifier $U_d$ control                | 6  | Inverter VDCL (voltage-dependent current limit)  |
| 2 | Inverter $U_d$ control (voltage order) | 7  | Normal operating point                           |
| 3 | Inverter $\gamma$ control              | 8  | Rectifier $I_d$ control                          |
| 4 | DC line drop                           | 9  | Rectifier VDCL (voltage-dependent current limit) |
| 5 | Inverter $I_d$ control                 | 10 | Current order                                    |

**Figure 21 – Converter voltage-current characteristic**

It should be specified which control strategies are intended to be used and at which priority they should be operable under different operating and AC system conditions.

The power control tolerance is dependent upon the accuracy of the voltage divider, the current sensor and the resolution of the power order. A typical tolerance value is about 1,5 % at rated power.

### 13.2.5 Master control

Master control is usually integrated into the HVDC station control. However, if two or more HVDC substations are connected to the same AC bus, the master control would be a separate level above the station control and include more sophisticated control strategies. It would interface with the AC system and coordinate the various substations. Master control can also be provided remotely, for example, at a dispatch centre. In this case, telecommunication ~~must~~ shall be provided from the dispatch centre to the HVDC substation.

### 13.3 Control order settings

Generally, both converters of an HVDC system are equipped with identical control equipment since most HVDC systems are designed to transmit power in both directions.

Only the station control in one location can be in the lead at one time. Generally, the setting of the station control order and rate of change are provided manually at the lead station. The changes in order are then executed in the other substation(s) via the telecommunication. Capability of the lead station for setting can also be transferred to a remote location, for example, a dispatch centre.

In the current control mode the current order can be set manually in both substations, if voice communication is available for coordination purposes. Current control can also be provided remotely, for example, at a dispatch centre.

Switching from power to current control mode may be ordered automatically after failure of the telecommunication channel or by command from the station control.

The resolution in the power order setting may be specified (typically 10 MW at a rated power of 1 000 MW). Its rate of change may be specified as well (for example, between 1 MW/min and 99 MW/min in steps of 1 MW/min).

Change in power direction is normally initiated from the lead substation, but could also be ordered automatically, if emergency reversal is called for, for example, after a disturbance in one of the AC systems.

### 13.4 Current limits

Various limits can be applied to the current order. The main objective of these is to optimize the permissible current with respect to main circuit components and cooling conditions. Examples of such limits are:

- a) overload of limited duration – permits overload for a fixed duration per 24 h period, for example, to take account of transformer temperature-rise limits;
- b) winter overload – permits overload when valve cooling conditions are favourable during low ambient temperature periods;
- c) dynamic overload – permits overload for short times based on transient thermal properties of thyristors and their coolers;
- d) other current limitation – because of loading limits for generators connected to the rectifier substation or for operation with reduced DC voltage or other system dynamic performance requirements;
- e) minimum current limitation – normally 0,05 to 0,1 per unit.

The limited current order can be transmitted between the two substations and synchronizing equipment ensures that the two substations at any particular time will be given identical current orders.

### 13.5 Control circuit redundancy

The user requirements for availability of the HVDC scheme may form the basis for specifying the reliability of the control system. Typically, to achieve a minimum possible bipolar outage rate, the control system incorporates redundancy or main and backup subsystems.

### 13.6 Protection system

The HVDC control and protection system should coordinate in terms of strategies, parameters, etc.

The HVDC protection system is used to detect and clear faults, isolate faulty equipment in order to recover the steady state of system (if possible). The protected zones are given in IEC 60919-2.

The HVDC protection systems are based on a fully redundant concept, arranged into overlapping protective zones and operated quickly and accurately.

The HVDC protection system sends the order to the control system to produce the trip signal to the converter AC breaker or directly trips the converter AC breaker, if it is required for fault clearing. Additionally, the HVDC protection system should send an order to the control system according to the severity of fault, such as:

- block converter (firing);
- forced retard;
- block bypass pair firing;
- converter / pole isolation;
- DC line fault clearing sequence;
- current limit;
- pole current balancing.

### 13.7 Measurements

Items of interest which are normally measured in an HVDC system are as follows:

- DC current;
- DC voltage and polarity;
- reactive power consumed by the converters;
- net reactive power including VAR banks and filters;
- AC current;
- AC voltage;
- AC power;
- energy;
- earth current;
- delay angle;
- extinction angle;
- tap-changer positions.

A decision should be made on which of these measurements is required, and whether they should be made on a per-pole basis, and at what accuracy.

The accuracy or tolerance requirements will be different according to the function for which the measurement is being made (control, protection, metering, indication, recording, etc.). As an example, the deviation between the set current order and the actual current is dependent upon the tolerance of the current control system and the current sensor. In this case, a typical tolerance requirement is less than 1 % at rated current.

## 14 Telecommunication

### 14.1 Types of telecommunication links

When the two terminals of an HVDC system are located a considerable distance apart, it is necessary to have a telecommunication system to exchange information between the two terminals. The most basic information to be exchanged relates to coordination of the two terminals during start and stop sequences. Fast communication between the two terminals can be used to enhance the performance of the HVDC system.

Alternative types of telecommunication can be used for control and operation of an HVDC transmission:

- a) telephone;
- b) power line carrier (PLC);
- c) microwave;
- d) radio link;
- e) optical fibre communication.

More than one system may be used.

### 14.2 Telephone

A public telephone network is one alternative communication link for HVDC transmission control. The basic need for voice communication between the stations for the correct timing of measures to be taken in the stations at operational changes can be satisfied by a dial-up connection. For the operation of the HVDC transmission from a dispatch centre with unmanned HVDC substations and to make use of the inherent HVDC system speed of response for control of transmitted power, a permanent telephone line is needed.

### 14.3 Power line carrier (PLC)

PLC is one means of communication for an HVDC transmission with overhead lines; however, its capabilities may be insufficient to meet the requirements of high-speed modulation control.

For an HVDC cable system, the transmission capacity of a PLC will be reduced for longer cable distances. A cable distance of about 150 km is the approximate limit for one duplex PLC channel.

When allocating frequencies for a PLC system which utilizes the HVDC transmission line for its carrier signal transmission, consideration should be given to the frequency coordination with other PLC systems of interconnected AC networks to avoid interference.

PLC over the HVDC transmission line ~~might well~~ can use a higher carrier frequency close to the HVDC substations to achieve a satisfactory signal-to-noise ratio with respect to possible converter interference. Lower carrier frequencies may be used at some distance from the HVDC substations because the lower frequencies have lower attenuation. Due consideration should also be given to possible interference at crossings between the HVDC and AC transmission lines.

#### 14.4 Microwave

While not necessarily essential for control of HVDC transmission, a microwave link may be the correct alternative for fast transmission of the large amounts of information needed to complement a more sophisticated control and protection of HVDC systems.

However, the signal levels of microwave telecommunication can be affected by weather conditions, such as heavy rain and fog since they absorb or scatter the microwave signal.

Proper selection of the microwave channel route is necessary for reliable and economical installation. Because of its line-of-sight characteristic, the system requires several reflection towers depending on geographical situation and repeater station(s) for intermediate signal boost to compensate for this attenuation.

Satellite telecommunication may be another choice for very long distance HVDC transmission schemes although it inevitably has communication delay time.

#### 14.5 Radio link

A radio link may be considered at long sea crossings with HVDC cable transmissions, when PLC does not provide sufficient speed.

#### 14.6 Optical fibre telecommunication

A fibre-optic communication link may be used for control and protection of HVDC systems and may be an economic alternative for fast transmission of large amounts of information with high immunity from interference.

This communication system is very fast (comparable to microwave systems) and reliable. Therefore, in addition to the basic requirements for operation of the HVDC system, sufficient additional bandwidth may exist to allow enhanced performance of the control and protection systems. Also, information capacity is sufficiently high that a variety of detailed operational data can be transmitted almost instantaneously. The data channels usually incorporate multiplexer technology for efficient utilization of the system.

Optical fibre can be laid for sea crossings; however, careful route selection is important since they are easily damaged by mechanical stress. Using composite DC power cables, in which optical fibres are enclosed, is another choice. If these cables are used, the reliability of the fibre optic communication in terms of mechanical stress can be compatible with conventional power cable and the total laying cost can be reduced. Use of OPGW (optical ground wire) as one of shielding wire is another typical arrangement used in many overhead lines schemes.

#### 14.7 Classification of data to be transmitted

A list of classes of the different types of information to be transmitted between the HVDC substations is given below. For each of these classes, the different requirements should be identified such as speed, resolution and reliability:

- a) order signals for continuous control:
  - power order;
  - current order;
  - frequency control;
  - damping control;
- b) operation orders:
  - change of control mode of operation;
  - interlocking of protection;

- operation of switches;
  - block/deblock;
  - power system security control;
- c) state indications:
- position of switches;
  - number of converters in operation;
- d) measured value;
- e) alarm signals;
- f) voice communication;
- g) DC line fault location.

Usually, these signals are transmitted in accordance with certain data formats, such as cyclic digital telemeter data format. Each data item is assigned to a group of bits sized according to the data format. In some cases, it may be undesirable to resend old data if an error is detected, for example, when sending power orders during swing damping.

#### 14.8 Fast response telecommunication

Several types of control may require a fast telecommunication such as microwave or optical fibre channel (greater than 1 200 bit per second (bps), (for example, 64 kbps)), for example:

- a) damping control of AC systems;
- b) frequency control of AC systems;
- c) fast power control of AC and HVDC systems;
- d) HVDC transmission line fault location;
- e) HVDC transmission line protection;
- f) power system security control.

The performance requirements of the telecommunications system(s) will depend on the specific demands placed on it by the HVDC control system, remote control facilities, etc. Since these vary widely between HVDC schemes, the telecommunications system specification shall be determined through detailed analysis of the particular HVDC system.

#### 14.9 Reliability

Generally, a telecommunication system can be provided with an automatic self-checking system.

If a redundant (stand-by) telecommunication system is available, automatic switch-over should be provided, thus maintaining the full degree of control of the HVDC system. If a redundant system is not available, then, after loss of communication, the operation of the HVDC system should continue uninterrupted under the defined control strategy not requiring telecommunication.

For microwave channels, signal fading is inevitable; however, the interruption period of a typical communication channel is around 10 ms. It is normally possible for the HVDC system to maintain the control signal data during the interruption, so it should be able to recover without interruption of the power flow.

Further high reliability can be achieved if several of the above-mentioned communication channels are combined. For example, a combination of microwave and fibre-optic communication channel enables uninterruptible, more reliable communication and flexible maintenance of these facilities. Also, dislocated installation of two sets of microwave systems (space diversity scheme) can mitigate a signal-fading problem across the sea.

## 15 Auxiliary power supplies

### 15.1 General

Auxiliary power supplies, which usually have a total rating equivalent from 0,2 % to 1 % of the HVDC substation, are needed for cooling pumps and fans, control, protection and motorized drives of disconnectors, etc. and for general substation service needs. To ensure adequate security of supply and freedom from interruption, these supplies are usually derived directly from the high-voltage AC network at the substation.

Where a separately and independently energized distribution network supply is available, this should be utilized as a back-up source to give added protection against failure of medium- and low-voltage switchgear and supply transformers.

### 15.2 Reliability and load classification

Short (for example, less than 5 s) interruptions in the auxiliary supply to the converter station should not disturb the HVDC power flow. Safe controlled shutdown of the HVDC substation should take place in the event that the AC bus has been tripped by the protection. (Since HVDC converters are line-commutated there can be no sustained transmission if the AC system generation is lost, although protection may be needed to prevent pseudo-commutation by filters or reactive power compensators).

Control, protection and data recording systems are not usually able to accommodate even a very short interruption in their power supplies. Accordingly, they are supplied from station batteries or, when AC supplies are needed, from an uninterruptible power system (UPS). Duplication of batteries is not always necessary, but full redundancy of the battery chargers and the UPS may be required to meet the desired reliability criteria. All breakers and disconnectors essential to the safe shutdown following a fault should be operated by stored energy, for example, compressed air or battery supplies.

Different considerations apply to the operation of disconnect switches and the closing of breakers to reinstate the transmission capability following a fault-caused shutdown perhaps at a lower capacity. If the requirement for a restart from a totally dead bus can be expected, a diesel generator may be necessary when adequate battery capacity is unrealistic.

Only brief interruptions in power for valve cooling fans and pumps can be allowed because of the short thermal time constant of thyristor valves. Automatic changeover between two independently derived supplies is preferable; but if one is dependent upon the distribution network, it shall be recognized that the security of such a supply will be rather low and the changeover should be such that reconnection to the primary system source is automatically accomplished as quickly as possible.

Since HVDC power transmission is possible only when the AC system bus is energized, the loss of auxiliary supplies during an AC system disturbance or converter disconnection does not cause a further loss of availability, unless the subsequent restart of auxiliary loads is delayed.

A lower security of supply can be accepted for those general station services the loss of which does not directly jeopardize the power flow. Even so, changeover capability between alternative and independent supplies should be regarded as the norm, but may not necessarily be automatic.

An emergency supply that will be maintained even when the HVDC substation is isolated from the AC network may be needed. Typically, this emergency supply will be from diesel generators and apart from supplying general services may be arranged to power the battery chargers, particularly if the possibility of prolonged outages can be anticipated.

### 15.3 AC auxiliary supplies

The total auxiliary load of the HVDC substation and the number and rating of motors larger than 30 kW should be established, at first to define approximately the overall auxiliary bus requirements. Secondly, details of possible sources of supply and the capacity, fault level and relationship to the point of coupling of the converter to the AC network need to be defined. This should be augmented with the aid of a single line diagram. From these data, it will be possible to specify security of supplies, duration of interruptions due to fault clearance, distortion, voltage and frequency limits. A voltage stability analysis should be carried out on any design proposal to ensure that changeover times and phase differences between alternative supplies, voltage reductions on motor starting and fault clearance are within acceptable limits.

Induction motors can be particularly ~~may be~~ sensitive to the amplitude of negative sequence voltage, low voltage or extreme frequency excursions. Finally, an accurate figure will be needed for loss guarantee purposes.

### 15.4 Batteries and uninterruptible power supplies (UPS)

It is usual to have separately assigned batteries to limit mutual interference for at least:

- HVDC system control for each pole;
- other substation control and protection;
- telecommunication equipment.

These batteries will usually be of different rated voltages. The time for which each battery can supply its rated load, within the rated voltage range in the event of failure of the charger or its supply, should be specified. A typical time is 6 h. The charging time, while the charger is supplying the rated load and the recharge current for the battery, should also be specified. A typical recharge time is 10 h to achieve a minimum state of charge of the battery of not less than 90 %. In addition, the acceptable ripple voltage and the superimposed ripple current shall be considered. A room should be set aside for batteries and chargers, but with modern equipment there is no justification for separating the two items.

For batteries, it is necessary to consider and specify the following:

- nominal voltage;
- load profile and/or rated capacity;
- voltage range from charge (when boost is necessary) to discharge;
- kind of battery and/or type;
- temperature conditions;
- ventilation requirements.

The charging system should meet the requirements of the battery and the load.

The UPS for AC loads can be based upon dedicated units or a common system for the HVDC substation. The latter is usually preferred because it makes the provision of adequate redundancy more realistic. Usually, the UPS will include its own assigned battery.

The following should be specified for the UPS:

- rated voltage, number of phases and permissible distortion;
- voltage frequency and tolerance;
- rated and maximum load;
- type of load;
- maximum allowable interruption for which the UPS should function.

Special consideration should be given to the last three items. UPS are often very sensitive to overload and surge starting conditions of induction motors, large storage capacitors or any other type of load having a substantial non-linear type characteristic. With many UPS the continuity of supply is only within the specified limits for the equipment and is not generally uninterruptible in an absolute sense. Care should therefore be taken that the UPS is correctly specified for the system requirements.

Reliability of the UPS shall also be carefully assessed. Many commercial quality systems suitable for enhancing the quality of distribution system supplies may actually degrade the security of the auxiliary supply in a converter where this is derived direct from the high-voltage system and is therefore inherently very secure, but non-interruptible.

### 15.5 Emergency supply

If a diesel generator is necessary, then consideration should be given to the following when preparing its specification:

- how much of the total auxiliary load should be supplied?
- should start-up, changeover and/or shutdown be automatic?
- if automatic, care should be taken to ensure that conditions causing frequent restarting cannot occur, otherwise the starting battery might become fully discharged,
- how much fuel should be stored on-site?

To ensure reliable operation when required by emergency conditions, it is desirable that the generator is started and loaded so that it reaches correct operating conditions periodically on a systematic basis. The auxiliary system should be designed to achieve this without in any way putting the transmission at risk by the failure of auxiliary supply equipment to make a correct changeover.

## 16 Audible noise

### 16.1 General

Noise from the HVDC substation could be troublesome and might incur prescriptive mandatory sanctions which may be difficult to resolve once the station is built. Therefore, limiting specifications should be prepared at the start of the project taking into account requirements of any applicable regulations or codes of practice. The effects of noise are generally treated as those concerning nuisance to the public outside the boundary of the HVDC substation and noise effects in the working environment. While the latter are important, public nuisance limits are often more difficult to specify.

### 16.2 Public nuisance

#### 16.2.1 General

The impact of HVDC substation noise on the public outside the confines of the substation, and whether or not it is seen as a nuisance, depends upon the noise level, the pre-existing level, the nature of the surrounding area and the nearness of residential property.

As a first step, the acceptable noise level at the boundary shall be specified having regard to the relevant factors. ISO 1996-1 gives a method for determination of an acceptable level. Next, the level and spectrum of noise expected from each major source should be defined. These can then be summed to decide whether or not the total noise will be acceptable. The location of equipment, that is the distance from the property line, is of particular importance. Special noise abatement measures may need to be used to keep the total to an acceptable figure.

Other noise-producing equipment may be installed at the same location and, if so, should also be considered, for example, AC system transformers and reactive power compensators.

Typical HVDC substation plant items most likely to produce significant noise are discussed below. When very low audible noise levels are specified at the boundary, the noise from other equipment, such as AC filter capacitors, diesel generators, etc., may also be significant.

### 16.2.2 Valves and valve coolers

The noise associated with indoor valves can usually be disregarded so far as the public is concerned, since in most cases the attenuation introduced by the valve hall will adequately suppress it. A main source of noise will probably be from the fans of outdoor coolers. These will usually be closed-cycle evaporative coolers or forced air coolers drawn from a standard product range and, as such, the cooling equipment manufacturer should be able to supply noise spectrum and level data. Evaporative coolers are generally less noisy. In both types, the noise level can be reduced by using larger, lower-speed fans. Substantial noise reduction can also be achieved by using screen walls to deflect the noise upwards.

### 16.2.3 Converter transformers

~~Converter transformer noise level is likely to be comparable to similarly sized a.c. system transformers; but,~~ Because of the effects of the harmonic currents, principally of orders 5, 7, 11 and 13 and the small residual direct current in the converter transformer valve windings, its noise spectrum ~~will~~ would be different from that of AC system transformers in actual operation and may be about 10 dB higher than would be measured in factory AC tests. The tank and cooler noise levels can be reduced by conventional means, if necessary, for example, enclosures, ~~mufflers and lower speed fans.~~

### 16.2.4 DC reactors

In the case of oil-immersed DC reactors, noise will come from the core, structure and coolers of the DC reactors. Core and structure noise can be expected to have peaks at ripple frequencies corresponding to the harmonic orders of 6 and 12. It is probably not practicable to carry out valid factory tests of DC reactor noise. The noise level can be reduced, if necessary, by some of the same measures as are applicable to transformers, for example, enclosures.

For air-cored DC reactors, and where low noise levels are required, special designs including the use of additional sound absorbent shields should be considered.

### 16.2.5 AC filter reactors

Filter reactors are usually air-cored, and modern manufacturing methods are available which may be used to reduce the amount of noise produced. Other measures may be taken to reduce the amount of noise propagated, such as careful consideration of the location within the converter station, sound absorbent barrier walls, or even locating the equipment inside buildings.

## 16.3 Noise in working areas

The noise level to which persons within the boundary of the HVDC substation may be subjected should be considered with regard to safety, hearing impairment, and the effects noise can have on working efficiency.

Many countries have established codes or mandatory regulations which seek to safeguard the hearing of those exposed to high noise levels and these should be examined and incorporated within the specification as appropriate. Problems of this kind are unlikely in HVDC substations other than during maintenance procedures and in the immediate vicinity of certain types of cooling fans or diesel generators. In most cases, it will be possible to meet the requirements of the regulations if maintenance personnel wear hearing protectors as necessary.

The general noise level within the building will be determined primarily by the valves and the indoor part of their cooling systems, any rotating machinery and by the DC reactors (and

transformers) where these are partially or fully enclosed within the building. Low noise levels should be specified where mental concentration is routinely expected, as in control rooms.

## 17 Harmonic interference – AC

### 17.1 AC side harmonic generation

Converter systems of all types are sources of voltage and current harmonics. To an AC network, the HVDC substation acts as a source of harmonic currents. These harmonic currents flowing into the AC system impedance give rise to harmonic voltage distortion. In addition, they can propagate throughout the AC system giving rise to local resonances or telephone interference.

If a converter is fed from a balanced three-phase source of voltage, if the impedances of the three phases are equal, and if the converter control angles are equal, characteristic AC side harmonics are generated of an order, determined by the pulse number,  $p$ , of the converter,  $kp \pm 1$ , where  $k$  is an integer. For the ideal case, the amplitude and phase of the generated characteristic harmonics in relation to the fundamental component depend solely on the control angle ( $\alpha$  or  $\beta$ ) and the overlap angle  $\mu$ .

However, in practice, AC systems that are coupled with HVDC converters are not perfectly balanced in voltage or phase. This leads to a negative sequence voltage system typically in the range 0,25 % to 1 % of the positive sequence system. Other sources of unbalance include converter transformer commutation inductance differences (typically  $\pm 2$  % to  $\pm 5$  %), and control angle unbalances (typically  $0,1^\circ$  to  $0,25^\circ$  in steady state for modern HVDC control systems). These unbalances result in the generation of non-characteristic harmonics, thus added to the harmonic interference from the converter.

### 17.2 Filters

AC harmonic filters are generally provided at HVDC substations for absorbing the harmonics generated by the converters, and in addition for reactive power compensation (see Clause 10). An example of AC harmonic filters connected to the AC feeders for a bipolar HVDC system is shown in Figure 22.

In order that the loss of any filter will not prevent system operation at full power, two filter arms of each type may be specified. The filter arms may be made switchable on the basis of individual arms on each pole. Sizing the individual filter to be switchable should take into consideration:

- reactive power and voltage regulation requirements;
- reduced and light load conditions;
- possible resonances between the filters and the AC network impedance with each switched arm;
- reliability criteria;
- economic constraints.

Filters of either the series-resonant RLC or the damped high-pass type are generally used on HVDC systems. Examples of the most frequently used filter types are shown in Figure 23.

For optimum harmonic filter design, the system impedance at harmonic frequencies should be known over the frequency range of interest. The AC system impedance of the HVDC substation may be specified by an impedance ( $R/X$ )-circle diagram over the frequency range from fundamental to the 50th harmonic.

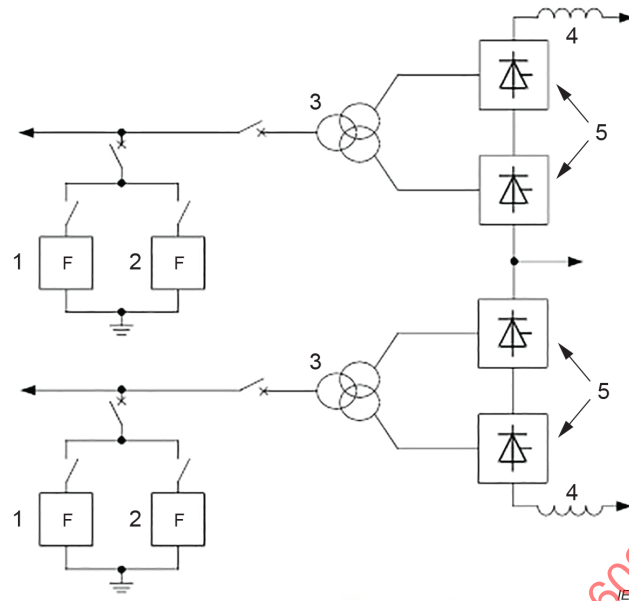

a) Separate AC system buses

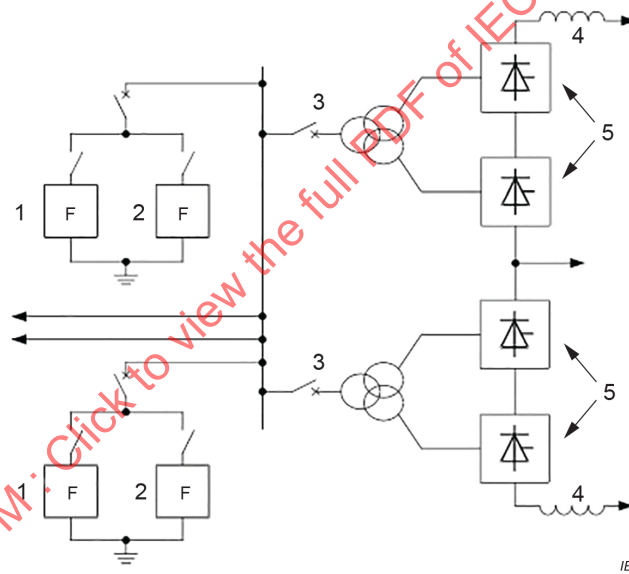

b) Common AC system buses

**Key**

- |   |   |   |            |
|---|---|---|------------|
| 1 | 11 <sup>th</sup> and 13 <sup>th</sup> harmonic filter | 4 | DC reactor |
| 2 | High pass filter                                      | 5 | Converters |
| 3 | Converter transformer                                 |   |            |

**Figure 22 – Examples of AC filter connections for a bipole HVDC system**

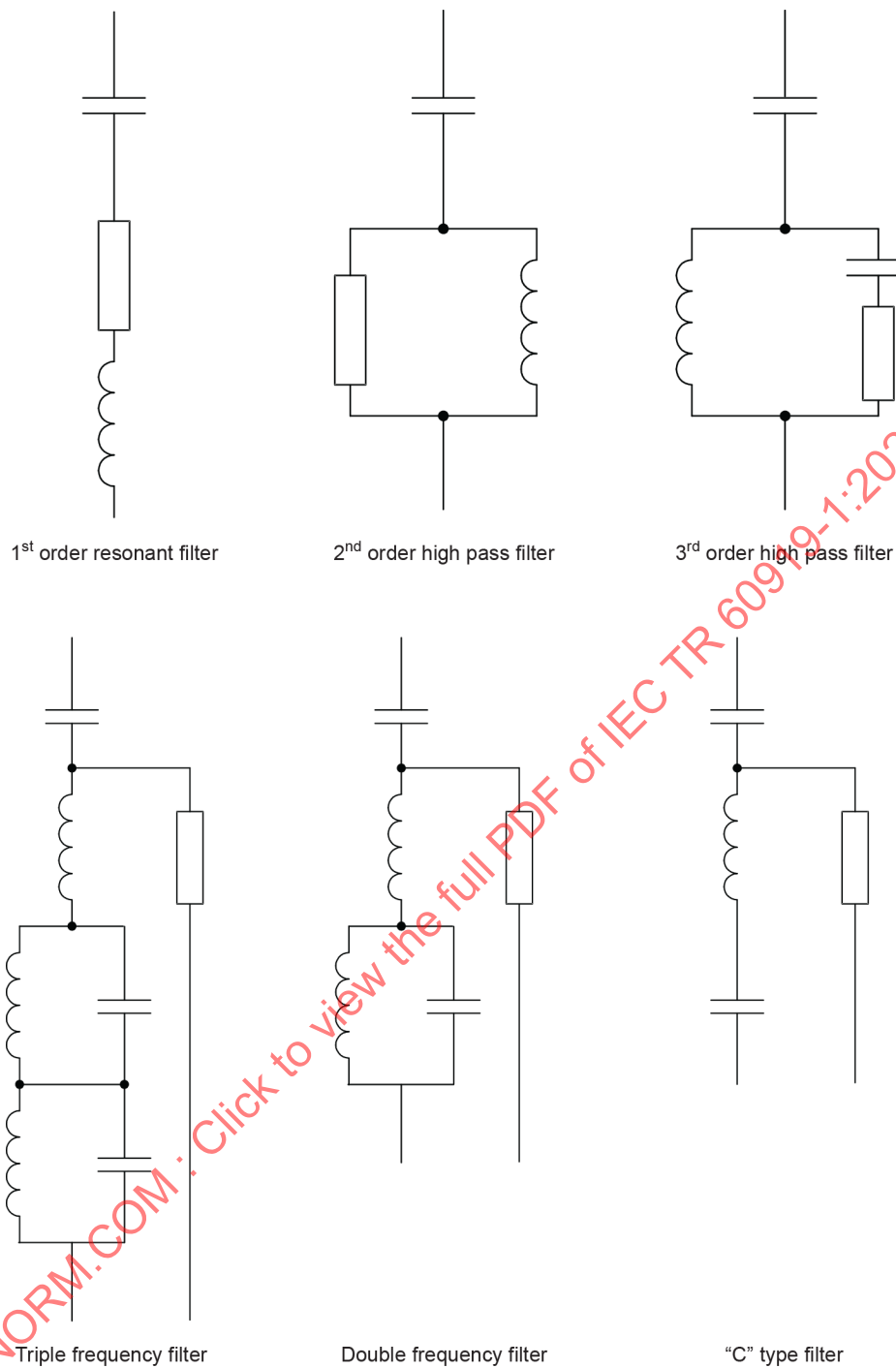

IEC

**Figure 23 – Circuit diagrams for different filter types**

Alternatively, the system may be specified in detail by harmonic impedances of lines and generators, etc., normally extending to five to eight buses from the HVDC substation, as discussed in Clause 9. The design of AC harmonic filters should also take into account any harmonics that may flow into the filters from other harmonic sources.

Where stringent AC harmonic performance requirements are specified, or in combination with CCC/CSCC HVDC circuit topologies, active AC filters are a suitable measure. Each active AC filter consists of a conventional passive filter connected in series with an active voltage source. The active parts are typically designed to mitigate harmonic voltages at several frequencies in order to improve the harmonic performance of the passive part. Alternatively,

active parts can be designed to mitigate the harmonic currents flowing in the AC lines which connect to the converter station.

AC filtering aspects including AC side harmonic generation, AC filter design, interference criteria and levels, filter performance and technical specification as well as monitoring issues are described and discussed in more detail in IEC TR 62001 (all parts).

### 17.3 Interference disturbance criteria

Interference performance is defined in terms of individual harmonic distortion  $D_n$ , total effective harmonic distortion  $D_{\text{eff}}$ , telephone interference factor TIF, telephone harmonic form factor THFF and weighted IT product. For telephone interference, two systems of weighting are used. These take into account the response of telephone equipment and the sensitivity of the human ear, namely, psophometric weighting as recommended by the International Telegraph and Telephone Consultative Committee (CCITT) and "C" – message weighting developed by Bell Telephone Systems (BTS) and the Edison Electric Institute (EEI). Each of the above terms is defined as follows.

Individual harmonic distortion according to CCITT or BTS:

$$D_n = \frac{U_n}{U_1} \times 100 \% \quad (9)$$

$U_1$  refers to rated fundamental RMS voltage and  $U_n$  to the  $n^{\text{th}}$  harmonic RMS voltage considered.

Total effective harmonic distortion:

$$D_{\text{eff}} = \sqrt{\sum_{n=2}^N D_n^2} \quad (10)$$

where

$N$  is the maximum harmonic order considered.

The telephone harmonic form factor (THFF in the CCITT system) and the telephone interference factor (TIF in the BTS system) are both used to describe the interference influence of a power transmission line on a telephone line, and serve as guidelines for specifying interference performance. THFF and TIF are defined in the same way with the only difference being the weighting factor:

$$TIF = \sqrt{\sum_{n=1}^{n=\infty} \left( \frac{U_n \times F_n}{U_1} \right)^2} \quad (11)$$

where

$F_n$  is the weighting factor for each harmonic  $n$  according to IEC TR 62001 (all parts).

$$THFF = \sqrt{\sum_{n=1}^{n=\infty} \left( k_f \times P_f \times \frac{U_n}{U_1} \right)^2} \quad (12)$$

where

$k_f$  is equal to  $\frac{f}{800}$ ;

$f$  is the harmonic frequency;

$P_f$  is the psophometric weight divided by 1 000.

For practical reasons the upper limit of  $n = 50$  is recommended.

The approximate relationship between TIF and THFF is:

$$\frac{TIF}{THFF} = 4\,000 \quad (13)$$

that is, for example, a TIF equal to 40 is roughly equivalent to a THFF equal to 1 %.

The harmonic currents of power transmission lines are represented by a single current obtained by weighting each harmonic current with the corresponding factor of the system used.

The weighted current product (IT) is computed as follows:

$$IT = \sqrt{\sum_{n=1}^{n=\infty} (F_n \times I_n)^2} \quad (14)$$

where

$I_n$  is the  $n^{\text{th}}$  harmonic RMS current;

$F_n$  is the same as defined before for TIF.

Calculation of the weighted current products (IT) for individual lines requires a knowledge of the harmonic impedances of individual lines connected to the converter AC bus in order to be meaningful in specifying interference performance for HVDC installations. The IT product should be specified for individual lines, but only if the harmonic impedances of all lines from HVDC substation AC bus are specified.

Specifying performance limits simultaneously for all harmonic interference factors ( $D_n$ , TIF and IT) may not be practical if the values have to reflect the real impact of the injected harmonics on inductive coupling. This is particularly true if IT is specified for meshed systems. These values vary from station bus to station bus and along the line; thus, acceptable performance can only be ensured in the design if line parameters, soil resistivity along the transmission line, geometric coupling factors, etc., are accurately known.

#### 17.4 Levels for interference

Examples of typical maximum levels of harmonic interference factors that have been specified for an HVDC substation are as follows (these are not recommended specification values and should not be taken as limits without specific studies of a given system):

- a) individual distortion  $D_n$ , 1 % at any harmonic;
- b) effective harmonic distortion  $D_{\text{eff}}$ , 2 % to 5 %;
- c) telephone influence factor TIF 25 to 50; THFF in the range of 0,6 % to 1,25 %;
- d) IT product 25 000 to 50 000 per line.

If generators are connected near the HVDC substation, the sum of the negative sequence 5th and positive sequence 7th non-characteristic harmonic currents flowing into any generator should be considered in the design specification for the HVDC substations.

## 17.5 Filter performance

HVDC system operating conditions that should be considered when specifying performance requirements of AC harmonic filters include the following:

- range of DC current values from minimum to the specified overload;
- reduced DC voltage operation over the range of required DC current values for the reduced voltage operation;
- operation at larger-than-normal angles for reactive power absorption as specified;
- operation with any filter bank or reactive power source out of service. A filter bank is understood as one filter element that can be removed from service by switching equipment. This condition should apply only for the normal operating modes of the HVDC transmission system;
- steady-state range of AC power system frequency and voltage;
- loss of capacitor units to the extent that it results in a first-level alarm;
- extremes of ambient temperature conditions coupled with maximum filter loading;
- initial filter detuning;
- any change in system configuration.

Filters should not be required to meet performance limits under the following conditions, but should be capable of operation without damage:

- emergency frequency variations as specified;
- dynamic overvoltage conditions including ferroresonance following load rejection or fault recovery;
- short-term overload.

When specifying harmonic interference limits for an HVDC substation, certain data (as discussed in Clause 9) should be included in the specification to enable appropriate optimization of AC filter designs.

## 18 Harmonic interference – DC

### 18.1 DC side interference

#### 18.1.1 Harmonic currents in HVDC transmission line

The operation of the converter equipment in an HVDC substation generates harmonic voltages in the DC side of the substation which cause harmonic currents to flow in the HVDC transmission line. Where the transmission line consists of overhead line and cable, the cable generally acts as a filter to the harmonic current, so that only harmonic currents of small magnitudes flow into the line beyond the cable. Such systems still require evaluation for interference along the overhead line section. Underground or submarine DC cables are so well shielded that generally no noise problem exists on the DC side.

#### 18.1.2 Characteristic and non-characteristic harmonics

In modern converter unit design, 12-pulse converter units are generally used, resulting in characteristic harmonics of the order of  $12k$  ( $k$  being an integer). In addition to these "characteristic" harmonics, which appear under idealized conditions, there are also harmonics of other orders, the "non-characteristic" harmonics. The characteristic harmonic voltages generated by the converter operation depend on the following factors: direct voltage, direct current, the commutating reactances and the firing angle. Non-characteristic harmonic voltages are caused by such factors as differences between the firing angle, unbalances in the commutating reactance and asymmetry in the network AC voltage (negative sequence voltage component) feeding the converter.

The leakage capacitances to ground in the converter transformers shall also be taken into account when calculating the harmonic currents. In particular, with respect to the calculation of the non-characteristic harmonic currents, the three-pulse harmonic voltage model should be used.

### 18.1.3 Groups of harmonics

Two groups of harmonics should be considered: the higher order harmonic group (7th to 48th), responsible for the voice telephone interference and the low order harmonic group (1st to 6th) that may introduce other interference problems, such as the following:

- a) personnel and equipment safety from induced voltage;
- b) effects on data transmission and railway signalling circuits;
- c) effects other than voice interference in voice communication circuits;
- d) secondary induction effects;
- e) possible excitation of resonance conditions between the HVDC transmission line and the earth electrode line;
- f) unacceptable DC current in the converter transformers.

### 18.1.4 Calculation of harmonic currents

The harmonic currents circulating in the HVDC transmission line poles and in the overhead shield wire can be calculated by the usual formulae for long-line calculations and model analysis, in case there are unbalances in the circuit. If the distance between the HVDC transmission line and an open-wire telephone circuit is short (less than 200 m), the calculation should be carried out considering the currents in the poles and in the shield wire(s) separately, with their respective coupling factors.

In computing the longitudinal noise voltage imposed on a voice communication circuit, the harmonic currents are weighted by a factor (psophometric or C-message) to take into account the response of the human ear to each frequency.

### 18.1.5 Calculation of induced voltages

The longitudinal C-message or psophometric voltage  $V_g(x)$  induced per km of exposure of a telephone circuit can be calculated considering the currents coming from both ends of the HVDC transmission line, at any location  $x$  km from one end of an HVDC transmission line, the weighting factor, the shielding factor of ~~commutation~~ communication circuits and the mutual impedance between the HVDC transmission line and the communication circuit. The transverse voltage is given by  $k_b V_g$  where  $k_b$  is the balance factor of the communication facility being considered.

### 18.1.6 Personnel safety

When considering personnel safety, the voltage value is calculated as the square root of the sum of the squares (r.s.s.) of the induced harmonic voltages to earth, flat weighted. For the other interference problems in non-voice communication circuits, there is no standardized procedure and therefore the procedure to be used should be agreed upon between the parties involved.

### 18.1.7 DC filters

DC filters are used to reduce the magnitude of the harmonic currents circulating in the HVDC transmission line to avoid unacceptable interferences. The need for the DC filters depends upon the following:

- a) the characteristics of the HVDC transmission system, overhead line or overhead line and cables;
- b) the earth resistivity;

- c) the density, proximity and type of telephone and railway signal circuits near the HVDC transmission line route.

When establishing the need for a filter scheme, other cost-effective means available to satisfy the noise criteria should be taken into consideration. The evaluation should consider any changes in the communication circuits, as well as modifications to the HVDC substation, such as,

- use of a DC reactor, already required for other reasons, either with or without a reduced level of filtering;
- capacitors connected between the earth electrode line connection and earth, to form a resonant circuit with the electrode line inductance;
- switches to permit paralleling of the two (pole) filters when in monopolar operation.

The influence of these on the operation and on the overall performance of the converter substation should be examined before deciding on the extent of needed limitation of the harmonics on the DC side.

While routing the DC line, it shall be evaluated if parallelism of other lines can be avoided or reduced, as this would be the most effective way to avoid/limit interference. Where possible, crossing to lines should be made at 90 degrees and transposition of phases/pole lines shall also be considered.

## 18.2 DC filter performance

### 18.2.1 Requirements for voice communication circuits

Understanding of the communication and railway companies' requirements is necessary to arrive at the best overall solution for interference problems. Table 2 indicates the requirements for voice communication circuits, prescribed by CCITT, the American Telephone and Telegraph Company (AT&T) and the US Rural Electrification Administration (REA).

### 18.2.2 Levels of interference

When defining the filter performance, the levels of interference should be specified for the operating modes of the HVDC system. From the interference point of view, bipolar operation with equal positive and negative voltages is the mode requiring less filtering. Monopolar operation, with either earth or metallic return, gives higher values of noise voltage than bipolar operation for the same DC filter configuration; however, operation in this configuration usually occurs for a low percentage of time. Monopolar operation with metallic return gives less interference than monopolar operation with earth return.

In addition to the basic HVDC operating modes discussed above, the specification should indicate any other modes or conditions under which the transmission system could eventually operate. The filter should be rated for all these conditions; however, the interference level under the several modes or conditions should lie between the normal bipolar balanced operating mode and the worst monopolar mode. Provision may be made in the specification for the system capability for emergency operation.

### 18.2.3 Safety

As to personnel safety, there is not yet a specific limit for hazardous induction caused by harmonics. For the fundamental frequency (50 Hz and 60 Hz), the CCITT and the AT&T prescribe 60 V AC RMS and 50 V AC RMS, respectively. These limits should be considered as the maximum r.s.s. value of the induced longitudinal harmonic voltage for the low order harmonics (1st to 6th), for personnel and equipment safety. In addition, any higher order harmonics with unusually high current values should also be included in the r.s.s. calculation.

**Table 2 – Performance parameters for voice communication circuits:  
Subscribers and trunk circuits**

	CCITT	AT&T <sup>a</sup>	REA
1. Balance cable circuits	50 dB to 60 dB	60 dB <sup>f</sup>	50 dB to 60 dB <sup>c</sup>
Open line	46 dB to 56 dB	50 dB <sup>f</sup>	50 dB <sup>b</sup>
2. Transversal (metallic)	26 dBrnC		
Noise limit	26 dBrnC	20 dBrnC <sup>d</sup>	31 dBrnC <sup>e</sup>
26 dBrnC	(20 dBrnC) <sup>d</sup>		
<p><sup>a</sup> It is North American practice (AT&amp;T) to use a characteristic impedance of 600 Ω for a trunk circuit and 900 Ω for a subscriber circuit. CCITT and REA use 600 Ω both for a trunk circuit and for a subscriber circuit.</p> <p><sup>b</sup> Information from BTS indicates that minimum balance should be 60 dB.</p> <p><sup>c</sup> The US Rural Electrification Administration prescribes other values for balance. This value corresponds to a good balance.</p> <p><sup>d</sup> This value is the total noise. From a single source (HVDC line, for example), the maximum value should be 17 dBrnC. 0 dBrnC corresponds to 10<sup>-12</sup> W (1 pW) at 1 000 Hz.</p> <p><sup>e</sup> This value refers to trunk circuit.</p> <p><sup>f</sup> The value in brackets refers to design objective and the other to the maximum acceptable value. In practice, for bipolar systems, the performance requirements of a DC filtering scheme are primarily based on the bipolar operating mode. A higher interference level on voice communications is accepted during monopolar operation, for example, two or three times the level permitted during bipolar balanced operation.</p>			

### 18.3 Specification requirements

#### 18.3.1 Economic level of filtering

The preferred way to determine the economic level of filtering that satisfies interference performance requirements would be to perform an inductive coordination study and optimize the cost of filters with the cost of changes in the communication circuits, considering the points discussed earlier. From such a study, the ideal specification for the filters could indicate the profile of the maximum disturbing current along the line, as defined in 18.3.4, required to maintain the interference level below the specified values.

Usually, the above studies are not feasible during the specification stage; therefore, one of the following three alternative approaches could be adopted.

- a) Specify one maximum longitudinal induced noise level in parallel test line, 1 km away from the HVDC transmission line for bipolar operation and a higher value for monopolar operation, in mV/km of exposure. This approach should be used with caution as it accounts only for the interference in the telephone voice circuit and it utilizes maximum values for the harmonic current along the line. This method could be improved by adding the requirements for the r.s.s. of induced low-order harmonic longitudinal voltage and different values of the induced voltages along the HVDC transmission line route, depending on the variation of the soil resistivity, quality, type and density of the telephone circuits and the disturbing current variation along the line, etc.
- b) Establish the filter cost based on the non-simultaneous maximum values for each harmonic current (on a pole basis), at the HVDC transmission line terminals, and subsequently select the optimum design after a complete inductive coordination study. This procedure has some of the drawbacks of the previous one, and the method to establish the set of harmonic voltages is complicated due to other considerations discussed in 18.3.3.
- c) For the third alternative, the following steps should be taken.
  - 1) Obtain information on the characteristics (shielding and balance factors, length, routes, etc.) of the communication lines and railways, installed or planned, within the area of influence of the HVDC transmission line (10 km from the centre line of the right of way, for example).

- 2) Perform tests on representative soil samples taken within the limits of the area of influence of the HVDC transmission line, to determine the different values of earth resistivity to be considered in the inductive coordination studies.

With the information obtained and considering the normal mode of system operation (bipolar), it should be possible to establish two profiles of disturbing currents and two limits of the maximum allowable low-order harmonic current magnitudes:

- one not requiring any change in the communication circuits, and
- the second requiring, for example, changes in perhaps 25 % of the communication circuits located in the area of influence.

Finally, with the information on filter cost and the cost for changes in the communication circuits, it should be possible to determine the optimum trade-offs between the filtering system and communication circuit changes.

### 18.3.2 General criteria

In addition, for specifying the level of filtering in accordance with one of the alternatives indicated above, the following general criteria should be followed.

- 1) The level of harmonic current filtering should be determined under bipolar balanced operation and under the nominal condition defined for the HVDC system. For any other operating mode or condition specified, the level of noise should not be higher than the one resulting from the worst monopolar operation, except for the unusual contingency of operation without filters.
- 2) The specification should also define the maximum value of the disturbing current profiles to be accepted under monopolar operation.
- 3) In addition to the above requirements, the maximum low-order harmonic current values (1st to 6th) should be specified.
- 4) The utility should also specify the limits of system operating conditions under which the filter performance requirements should be met for each mode of operation and for each stage of development of the HVDC system. For example the following:
  - a) range of direct voltage and direct current;
  - b) range of normal operating AC bus voltage;
  - c) negative sequence component of fundamental frequency AC voltages;
  - d) maximum AC frequency deviation within a normal cycle range or which may be maintained for more than 1 min;
  - e) maximum temperature variations expected;
  - f) maximum number of capacitor unit or element failures permissible before mandatory filter removal, and
  - g) initial mistuning to the limit possible in the design.

### 18.3.3 Factors to be taken into account for calculations

The performance calculations should take into account the following:

- 1) Calculation of the harmonic current profiles to determine compliance with the performance specified should consider the phase-angle relationship between the AC systems; the most onerous combination of firing angles; direct current magnitudes; leakage capacitances to ground in the converter transformers; commutation reactance differences among the phases of a six-pulse bridge, between the transformers of the six-pulse bridge in a 12-pulse unit, between 12-pulse units of a pole and between poles of a bipole, that will result in the worst consistent set of harmonic driving voltages. The consistent set of harmonic voltages consists of voltages occurring simultaneously and giving the highest value of C-message or psophometric profile of disturbing current along the line and also complying with the levels of low order harmonic currents specified.

For the alternative b) indicated in 18.3.1, the set of harmonic driving voltages to be considered should be the highest non-simultaneously occurring harmonic voltages.

- 2) The frequency dependent parameters of the HVDC transmission and earth electrode lines, as well as their termination and the characteristics of the earth electrode as given in the specification, should be taken into account.
- 3) The variation of the inductance and resistance of the DC reactor with load and frequency should be considered in determining the harmonic currents flowing to the HVDC transmission line.

#### 18.3.4 Calculation of currents

For the purpose of meeting the performance criteria specified, the magnitude of the current at each frequency and at any point along the HVDC transmission line should be considered as the RMS value of the contribution at that point from the sending end and from the receiving end of the HVDC transmission line, for the frequency being considered, using the following formula:

$$I_{e,x} = \frac{1}{C_{800}} \sqrt{\sum_f (C_f \times I_{x,f})^2} \quad (15)$$

where

$I_{e,x}$  is the equivalent disturbing current at 800 Hz, at point  $x$  along the d.c. line;

$f$  is the frequency of the harmonic current to be considered from the fundamental to the 48th harmonic;

$C_f$  is the psophometric C-message weighting factor at frequency  $f$ ;

$C_{800}$  is the value of  $C_f$  at 800 Hz;

$I_{x,f}$  is the harmonic current of frequency  $f$ .

In cases where the separation between the HVDC transmission line and the telephone line is less than 300 m or less than about 100 m for earth resistivity equal to, or higher than, 10 000 Ohm  $\times$  m the equivalent disturbing current,  $I_p$  at 800 Hz should be calculated using the following formula:

$$I_{p,x} = \frac{1}{P_{800}} \sqrt{\sum_f (h_f \times A_f \times I_{x,f})^2} \quad (16)$$

where

$P_{800}$  is the psophometric weight at 800 Hz divided by 100;

$h_f$  is the factor depending on the type of coupling at frequency  $f$ ;

$A_f$  is the C-message weighting value at frequency  $f$ .

The characteristic and non-characteristic harmonic currents should be calculated giving both magnitude and angle. Alternatively, for the non-characteristic harmonic currents, an average angle of 90° should be assumed as the angular displacement of the non-characteristic harmonics of two poles in a bipole.

An internal source reactance not higher than  $\frac{2n-1}{2n}$  times the total commutating reactance of the pole ( $4x_t$  per 12-pulse converter unit) should be used, where  $n$  is the number of six-pulse bridges in operation for the mode of operation being analysed.

$$I_{\text{eq}} = \sqrt{\sum_{n=1}^{n=N} (H_n \times C_n \times I_n)^2} \quad (15)$$

where

- $I_n$  is the effective disturbing current at harmonic  $n$  (generally corresponding to residual mode current);
- $N$  is the maximum harmonic number to be considered;
- $C_n$  is the C-message weighting factor;
- $H_n$  is the weighting factor normalized to reference frequency (1 000 Hz) that accounts for the frequency dependence of mutual coupling, shielding and communication circuit balance at harmonic  $n$ .

Where the balanced mode harmonic currents are expected to contribute significantly to the induced noise, they shall be included in the calculation of  $I_{\text{eq}}$ . The effective disturbing current is then specified as:

$$I_n = \sqrt{(I_{rn})^2 + (K_b \times I_{bn})^2} \quad (16)$$

where

- $I_{rn}$  is the total residual mode current at harmonic  $n$ ;
- $I_{bn}$  is the balanced mode current at harmonic  $n$ ;
- $K_b$  is the ratio of balanced mode coupling to the residual mode coupling at reference frequency.

The typical values of equivalent disturbing current are in the range of 100 mA to 6 000 mA for normal operation.

## 19 Power line carrier interference (PLC)

### 19.1 General

Power line carrier interference from an HVDC substation is produced by the turn-on and turn-off sequences in the valves. The dominant component is produced during the voltage collapse in the turn-on sequence. These transients excite localized resonant circuits formed by the stray capacitance and inductive elements in the HVDC substation: transformers, reactors, bushings, etc. Interference energy is dependent on the magnitude of the voltage jumps produced by turn-on and turn-off of the valves as well as circuit parameters. Converter ~~noise~~ interference is somewhat independent of the current rating. However, it depends strongly upon the firing angle.

~~Noise~~ Interference that may affect the carrier includes conducted converter-generated ~~noise~~ interference, and AC or DC line corona ~~noise~~ interference. Conducted ~~noise~~ interference is strongly frequency-dependent with the highest ~~noise~~ interference levels present at the low end of the carrier frequency spectrum.

Field experience shows that thyristor valves generate about 10 dB to 15 dB less conducted ~~noise~~ interference than mercury arc valves.

Measurements have shown that corona on HVDC transmission lines is 10 dB to 20 dB less than that on AC lines for the same conductor surface maximum voltage gradient. Typical corona ~~noise~~ interference level ranges from –40 dBm to –30 dBm and is essentially constant in the carrier spectrum (20 kHz to 500 kHz) over the entire length of the HVDC transmission line.

RF filters can be specified to reduce conducted carrier ~~noise~~ interference on both the AC and DC side of the HVDC substations.

The filter series inductor elements and shunt capacitor elements should be rated for full current and rated voltage respectively. Therefore, economic consideration should be given to filter design ~~noise interference~~ alternatives based on existing carrier channel requirements, interference with other carriers, ultimate channel requirements, and the feasibility of channel movement from the lower end of the carrier frequency spectrum.

## 19.2 Performance specification

When specifying the performance of HVDC systems, the following carrier interference considerations are important.

If the utility wants complete freedom to use the entire allocated communications spectrum, then the HVDC interference specification should cover frequencies down to 20 kHz.

NOTE The carrier spectrum is becoming increasingly crowded on many electric power systems.

An example of typical carrier ~~noise~~ interference frequencies generated on the HVDC transmission line from solid-state converters is given in Figure 24.

For the design of the carrier filters, the specification should consider that harmful interference to power line carrier systems on HV transmission lines connected to the HVDC substations may be prevented by limiting the interference level from the HVDC substation over the power line carrier spectrum to  $-20$  dBm or less, measured in a nominal 3 kHz band, flat weighting.

Where dBm is defined as a means of interference measurement in which 0 dB is specified ~~at 0,775 V, this would be the voltage that would cause 1 mW to be dissipated in a 600 Ohm resistor~~ to 1,0 mW, which corresponds to 0,775 V pole-to-pole interference voltage assuming a line-to-line surge impedance of 600  $\Omega$ . In a 50  $\Omega$  cable on the low voltage side, 0 dBm and 1 mW corresponds to 0,224 V.

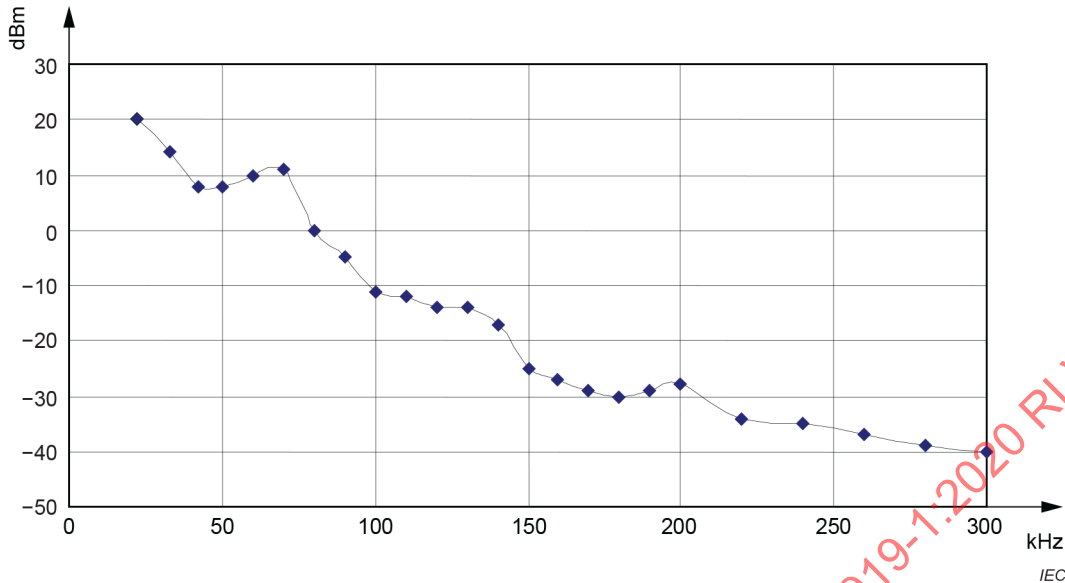

NOTE The converter interference levels are corrected and normalized to 3 kHz bandwidth -0 dBm = 1 mW corresponding to 0,775 V at a pole-to-pole surge impedance of 600 Ω.

**Figure 24 – RY COM-noise interference meter results averaged – Typical plot of converter-noise interference levels on the DC line-corrected and normalized to 3 kHz bandwidth – 0 dBm = 0,775 V**

If the carrier is present or planned in the frequency range 20 kHz to 100 kHz, filters will probably be required. The economics of filters for attenuation of noise interference, of course, should be evaluated. It should be considered that the cost for a broad band PLC filter is significantly higher than the cost for a narrow band PLC filter. Especially, filters for the lower frequencies 20 kHz to 50 kHz cost significantly more than PLC filters for higher frequencies. Therefore, it is probably most economical to specify PLC requirements only at individual frequencies used by PLC systems in the vicinity.

Instrumentation to be used for carrier interference measurement should be properly specified as to bandwidth (BW) and type.

By knowing the noise interference levels produced by converters, reasonable predictions can be made for the expected performance of a given carrier system.

The principal measure of performance for any given carrier system is primarily governed by the signal-to-noise interference ratio (SNR) at the receiving point of the carrier system.

## 20 Radio frequency interference

### 19.1 Radio interference (RI) from HVDC systems

#### 19.1.1 RI sources

RI energy at the HVDC substation is produced by the turn-on and turn-off sequences in the valves and from corona on the high voltage lines and switchgear.

The noise from valve operation is predominantly produced by the voltage collapse during the turn-on sequence. These transients excite localized resonant circuits formed by stray capacitance and inductive elements in the converter station transformers, reactors bushings, etc.

~~Corona generated RI is highest near the positive conductor and decreases with the radial distance from the conductor.~~

#### ~~19.1.2 RI characteristics~~

~~RI generated at the HVDC substation and propagated along the HVDC transmission lines appears to have the following characteristics:~~

- ~~a) Interference energy is directly proportional to the magnitude of the voltage jumps produced during turn-on and turn-off sequences of the valves and also depends on circuit parameters.~~
- ~~b) It has a high level of line to earth mode radiation interference near the HVDC substation, but this mode attenuates rapidly and becomes negligible within 15 km.~~
- ~~c) It has a line to line mode which can propagate hundreds of kilometres.~~
- ~~d) The noise is essentially independent of the operating current level.~~
- ~~e) The noise that comes out from the valve hall is predominantly the noise conducted through the wall or transformer bushings provided the valve hall is designed with good r.f. shielding.~~
- ~~f) The RI level does not increase appreciably as the number of converter units is increased from one to three.~~

#### ~~19.2 RI performance specification~~

~~The RI performance specification for an HVDC substation should consider the different consequences of RI, such as, interference with AM radio reception and interference with the operation of non-directional beacons (NDB). The specification should also require verification that the HVDC substation RI interference on other communication facilities such as VHF, microwave and UHF is within the specified limits. The limits to be established should include the RI due to dipole radiation generated by converter operation and the RI generated by corona.~~

~~The specification should define all steady state operating modes and conditions and weather conditions during which the basic criteria should be met.~~

~~Specification of a single basic criterion to be applied to all operating modes, at any load up to and including the full load rated value, and within the design range of firing angle, is recommended. This performance criterion should apply over the normal a.c. and d.c. operating voltage ranges and under fair weather conditions.~~

~~The RI performance criteria should apply at all frequencies within the range of 0,5 MHz to 30 MHz.~~

~~Measurements should be quasi-peak and should include at least three complete frequency scans at each measurement location. The RI level at a particular frequency should be considered the mean value of all measurements at that frequency and location.~~

~~Instrumentation for measurements should comply with CISPR 16 series.~~

~~The specification should indicate the rated range, band, and immunity level characteristics of NDBs to be protected against harmful interference from the HVDC substation. The protected bandwidth should be given in  $\pm$  kHz from the NDB frequency. As an example, this bandwidth has been specified as  $\pm 10$  kHz. In addition, the specification should give main data and location of the NDB installations to be protected. Generally, only the installations within a radius of 30 km from the HVDC substation need to be studied.~~

~~The most important item to be defined in the RI performance specification is the maximum RI level outside a defined perimeter around the HVDC substation.~~

~~In setting an acceptable level of RI ( $\mu\text{V}/\text{m}$ ), the noise contribution from corona and valve operation should be considered. The value to be specified depends on local conditions, such as, M radio station signal strength; the characteristics of the NDBS; any existing regulations as to the acceptable signal-to-noise ratio, etc.~~

~~An RI value of  $100 \mu\text{V}/\text{m}$  is a typical specification limit. For conventional HVDC substation designs, the specified RI value should not be exceeded at points along a perimeter line 500 m from any energized HVDC substation component. The contour line for measurement should also include the a.c. and HVDC transmission overhead lines leaving the HVDC substation at a distance of 150 m from the nearest conductor crossing the 500 m perimeter. As a rule of thumb, the contour line distance from the overhead a.c. and HVDC transmission lines will decrease linearly with distance along the transmission lines to half of the width of the line right-of-way at approximately 5 km from the HVDC substation.~~

~~The valve hall building design should incorporate necessary shielding to meet the RI requirements without any external switchyard screening. Special attention should be given to minimizing the length of the connection extending from the valve hall building.~~

~~The specification should require a statement on the proposed method of limiting RI within the specified design limit and should also include the data and curves relating to the expected radio interference within the entire frequency range (0,15 MHz to 30 MHz).~~

~~The RI levels should be calculated assuming earth resistivity as included in the specification for the substation sites and for 5 km from the substation, along the HVDC transmission line right-of-way.~~

## 20.1 General

Historically radio frequency interference (RFI) from high-voltage electric power installations has been related to interference with AM broadcast distribution due to high-voltage AC line corona. Consequently, this aspect is covered well in the literature and in relevant standards, i.e. CISPR 18 (all parts). RFI from substations has been of minor practical concern. Therefore very little has been documented regarding RFI from HV and MV substations. However, CIGRÉ Technical Brochure (TB) No. 391 provides a thorough analysis of the aspects related to RFI from substations, including HVDC substations. The analysis is based on both theory and measurement results.

One important aspect that is dealt with in the Technical Brochure (TB) is the attenuation of the RFI versus distance, including how the attenuation depends on the frequency.

RFI relates to a quite wide frequency range. According to CISPR 11, frequencies between 9 kHz and 400 GHz may be used for wireless communication and are therefore covered by the International Telecommunication Union (ITU) current international table of frequency allocations. Consequently, electromagnetic interference in this frequency range is defined as radio frequency interference (RFI). However, the frequencies below 150 kHz are nowadays sparsely used and the standards for frequencies above 1 GHz are under development.

## 20.2 RFI from HVDC systems

### 20.2.1 RFI sources

RFI energy at the HVDC substation is produced by the turn-on and turn-off sequences in the valves, from corona on the high-voltage switchgear and lines, and from sparking and gap discharge activities within the switchyard.

RFI from the valve operation is predominantly produced by the fast voltage collapse during the turn-on sequence. These transients excite localized resonance circuits formed by stray capacitance and inductive elements in the bus structures, bushings, reactors, converter transformers, etc.

RFI generated by the AC corona in the high-voltage AC switchyard of the HVDC substation varies significantly with the weather conditions and is highest during bad weather. RFI generated by the DC corona is highest near the positive conductor and decreases with the radial distance from the conductor. The DC corona does not vary very much with the weather conditions and is somewhat higher during fair weather.

Recent measurements have indicated that there may be significant high-frequency RFI from the AC part of a substation, especially during dry weather conditions if the substation is old. This high-frequency RFI is considered to be generated by gap discharge and/or sparking activities. For more information, reference is made to CIGRÉ TB No. 391.

### 20.2.2 RFI propagation

RFI generated in the HVDC substations may propagate as:

- a) a guided wave transmission propagating along the HVDC transmission line;
- b) a guided wave transmission propagating along the AC transmission lines;
- c) direct wave radiation from the HVDC substation.

The attenuation of the RFI versus distance varies with the frequency as follows.

For RFI propagating along the lines, the high frequency RFI vanishes after a few kilometres, especially the line-to-earth component that is dominating. However, low-frequency RFI will propagate quite a long distance, especially the line-to-line component.

Within a few hundred metres from the substation, the direct wave RFI can have quite a broad frequency range. However, when normal design is applied, the RFI has diminished to the background RFI level after 0,5 km to 1 km.

Details can be found in CIGRÉ Technical Brochure (TB) No. 391.

### 20.2.3 RFI characteristics

The general characteristic of the RFI from an HVDC substation is repeated transients regardless of whether the interference is produced by the commutation process, corona, sparking or gap discharge. Owing to the different sources, the frequency characteristics of the broad band RFI from a converter station can be quite complex and very irregular. To some extent this is valid for any high-voltage substation.

RFI generated by the commutation process of the HVDC converter has the following characteristics.

- a) Interference energy is directly proportional to the magnitude of the voltage jumps produced during the turn-on sequences of the valves and also depends on circuit parameters. The voltage jumps at turn-off have less impact as the rise time at turn-on is much shorter than the rise time at turn-off.
- b) As the RFI due to the converter commutation process depends on the circuit resonances, the frequency spectrum is quite irregular.
- c) The generated disturbance for an LCC converter starts to decay at around 100 kHz, and is negligible for frequencies above a few MHz.
- d) The interference that comes out from the valve hall is predominantly the interference conducted through the wall or transformer bushings if the valve hall is designed with good RF shielding.
- e) The interference level is essentially independent of the operating current. However, it depends strongly upon the firing angle.
- f) The number of converters has a minor impact on the interference level.

The dominant mode for all RFI generated in a substation is the line-to-earth mode.

### 20.3 RFI performance specification

#### 20.3.1 RFI risk assessment

The process for the specification should start with an RFI risk assessment regarding any local conditions requiring specific precautions regarding RFI. It should be noted that the risk for interference is related to nearby radio receivers, not to nearby radio transmitters. A nearby airport can imply an extra risk for RFI with the airplanes approaching the airport for landing.

Of special concern is interference related to the non-directional beacons (NDB) as their operating frequency is coincident with the frequency range for the converter RFI emission.

Also local communication centres with dual communication such as fire brigade stations should be considered in the risk assessment.

The important factors are the frequencies used, the bandwidth, the signal level, the interference-to-signal requirement and the distance to and the location of the antenna of the radio receivers.

#### 20.3.2 Specification RFI limit and its verification

The specified RFI requirement should include all sources related to the relevant delivery. The specification shall define all steady-state operation modes and conditions and weather conditions during which the criteria shall be met.

Basically a single basic criterion shall be specified to be applied to all steady-state operation modes, at any load, up to and including the full load rated value, and within the design range of the firing angle and in all weather conditions. The performance criterion should cover the normal AC and DC operating voltage ranges. The RFI performance should be verified by measurements performed in fair weather conditions.

The requirement should be specified as a graph of the maximum E-field in dB [ $\mu\text{V}/\text{m}$ ] versus frequency for the frequency band 150 kHz to 1 GHz. There should be one graph for the substation limit and one graph for line limits. Suitable limits for the normal cases are given in CIGRÉ Technical Brochure No. 391, with justifications. Since the frequencies in the frequency range 9 kHz to 150 kHz are sparsely used, a requirement should only be specified in case any communication is in use in the vicinity of the HVDC substation or connecting lines. Requirements applied unnecessarily in this low frequency range will introduce extra cost and a significant amount of extra losses in the form of large filters.

The recommended procedure for verification by measurements is shown in Figure 25. The recommendations are detailed in CIGRÉ TB No. 391.

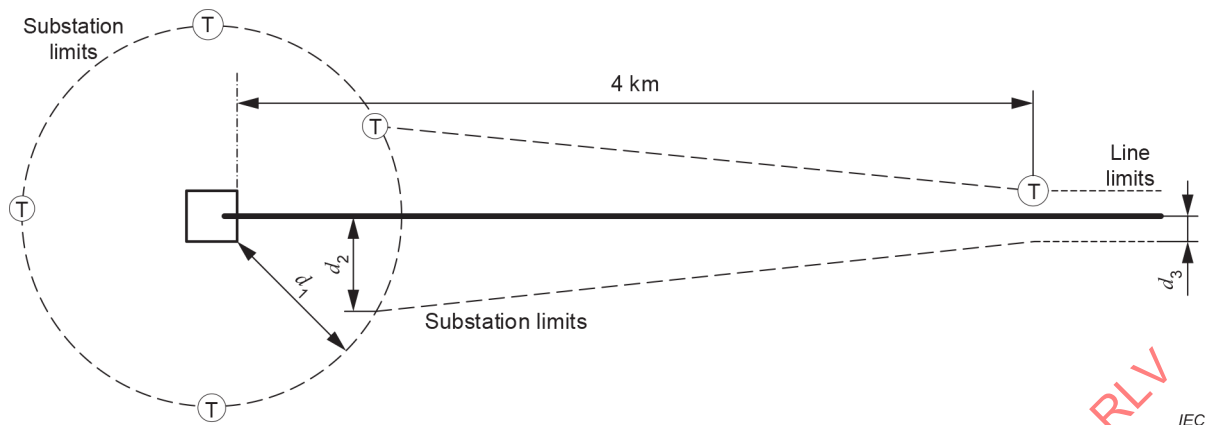

### Key

$d_1$  measuring distance for substations, normally 200 m for an HVDC substation

$d_3$  measuring distance for lines that are 30 m up to 600 kV AC and 50 m for higher voltages

$d_2$  one third of  $d_1$

T most relevant positions for measurement

**Figure 25 – Recommended measurement procedure with definition of measuring point**

The limits for substations in accordance with Table D.2 in CIGRÉ TB No. 391:2009 are applicable both for the contour around the active parts of substations and the closest part of the contour along the line. After a distance of 4 km, the limits for the line in accordance with Table D.3 in CIGRÉ TB No. 391:2009 apply.

The measurement shall be performed as a frequency scan over the entire RFI frequency range as the frequency characteristic may be very irregular. It is not sufficient to measure the RFI level at 0,5 MHz only, as often done for RFI due to AC line corona.

### 20.3.3 Design aspects

The valve-hall building design should incorporate necessary shielding to meet the RFI requirement without any external switchyard screening. Special attention should be given to minimizing the antenna area for loops with high-frequency transients conducted through the valve and the transformer bushings.

The specification should require a statement on the proposed method of limiting RFI within the specified limits. There should also be a statement regarding estimation of the expected RFI level by calculation during the design stage, within the entire frequency range. This estimation shall cover both the RFI from the substation and the RFI from the line, as defined in Figure 25. Outdoor AC yards/substations shall be designed and built, applying the most efficient methods for corona-reduction, to be as corona-free as technically possible. Further, HV apparatus are tested for RFI at factory, following available praxis and standards.

## 21 Power losses

### 21.1 General

It is normal practice to establish loss figures for HVDC substations under rated power (Clause 6) and no-load operating conditions (8.4) so as to permit an economic evaluation of the losses. In addition, losses at minimum load (8.2) or other intermediate levels may also be evaluated using the appropriate weighting factors.

HVDC system losses can be determined by the summation of losses of the main contributing sources. Loss figures are usually based on a combination of calculations, factory tests and

field tests, since determination of total losses by field tests alone is not practical because of inadequate measuring accuracy.

The relevant environmental conditions, as well as methods of calculation should be specified. The tolerances for all loss measurements should be established.

If the HVDC system is erected in stages, then the loss figures per stage should be determined. Total efficiency figures for monopolar and bipolar operation under the specified conditions should be verified.

Determination of power losses in HVDC converter stations is described in detail in IEC 61803.

## 21.2 Main contributing sources

### 21.2.1 General

For most HVDC equipment, harmonic currents contribute appreciably to total equipment losses. The basis for calculation of these harmonic losses should be specified. Temperatures at which losses are to be determined should be given.

### 21.2.2 AC filters and reactive power compensation

Loss figures are calculated for the AC filters and reactive power compensation. The harmonic losses in these are strongly load-dependent. The loss figures should include all harmonic effects produced by the converters. Unless otherwise specified, harmonics entering from the AC system should not be taken into account in these calculations. For no-load loss calculation, none of the filters and reactive power sources is assumed to be connected. For rated load, it is assumed that all filters and reactive power sources which are needed to provide the specified power factor are connected and all harmonics enter the filter only. For intermediate loads, the operating conditions should be specified. For static and synchronous reactive power compensators, the operating conditions should also be specified.

### 21.2.3 Converter bridges

Converter bridge losses can be calculated based on measurements made in the factory on the individual bridge elements. Loss figures include losses in all the components used in the bridges, for example, valves, ~~snubber~~ damping circuits, reactors, etc. assuming firing and overlap angles as required for the specified load condition. Under no-load, valves are assumed to be energized but blocked. All valve-cooling equipment losses required for the specified load conditions should be included.

### 21.2.4 Converter transformer

The fundamental frequency losses in converter transformers can be established by no-load and short-circuit measurements in the factory with harmonic losses taken into account by appropriate computation. All cooling equipment losses should be included as far as their operation is required for the specific load condition.

### 21.2.5 DC reactor

Direct current losses can be measured in the DC reactor at the factory and adjusted for the specified ambient temperature. Its harmonic losses should be calculated. All cooling equipment losses should be included as far as their operation is required for the specified load condition.

### 21.2.6 DC filter

DC filter losses are calculated taking into account the ~~harmonics~~ harmonic currents actually entering the filter at the specified load conditions with the control and overlap angles as

needed at those conditions. All converter ~~harmonics~~ harmonic currents are assumed to enter the DC filter.

### 21.2.7 Auxiliary equipment

This equipment includes cooling (except converter transformer, DC reactor and ~~valve converter bridges~~ cooling), control, heating, lighting of the HVDC substation and auxiliary transformers. Losses can be determined as the summation of the measured or calculated losses of all individual items. Only that equipment which is needed for the specific operating point in meeting all requirements of the specifications should be included in the loss calculation.

### 21.2.8 Other components

Losses in other components such as voltage and current transformers, RI filters, etc., should be determined under specified conditions (load level, ambient temperature, etc.).

## 22 Provision for extensions to the HVDC systems

### 22.1 General

If extensions to HVDC systems are scheduled or planned in the future through separate specifications, the various applicable conditions after the extensions should be considered in advance. Otherwise, economically and technically disadvantageous situations might arise. Therefore, it is necessary to specify, as far as possible, the conditions for each step of the extensions applying to Clauses 4 to 20. For the scope of the equipment installations at each stage of the extensions and the performance specifications, careful consideration should be given to the complexity of the field work, to minimize the influence of the field work and field tests on the operation of the existing system, to economy of advance investment and to the system performance requirements at each stage. The following matters listed in 22.2 should be specified in as much detail as possible to the extent they can be anticipated and included in the statement of the scope of extensions.

### 22.2 Specification for extensions

The specifications for extensions consist of the following:

- a) Rated capacity, voltage and current in each stage of extensions.
- b) Form of converter bridge extensions (Figure 26):
  - 1) series;
  - 2) parallel;
  - 3) monopolar to bipolar;
  - 4) multi-terminal, series or parallel.

Any special operating modes planned for the future, such as switching of poles from series operation to parallel operation during the outage of an HVDC transmission line pole as discussed in Clause 4 should be described.

- c) AC system parameters after each stage of the extensions:
  - 1) additional AC lines;
  - 2) changes in nominal and range of steady-state AC voltage;
  - 3) additional generators;
  - 4) increased short-circuit capacity.
- d) Reactive power balance after each stage of the extensions:
  - 1) reactive power source to be installed at the HVDC substation;
  - 2) reactive power supplied from the AC system.

e) Circuit configuration and line characteristics of the HVDC transmission line(s) after extensions.

f) Change of the control and protection mode after extensions, if planned.

**NOTE 1** The extension work on control and protection ~~may~~ can restrict the operation of existing equipment for a long period. In this connection, therefore, the scope of control and protection equipment to be installed in each stage of extension should be examined.

g) The allowable levels of audible noise, carrier interference and harmonic interference in each stage of extension should also be specified, including the levels in the final stage after completion of extensions.

h) Order of extension of AC and DC filters.

**NOTE 2** When the HVDC transmission line voltage changes as a result of extension, the design of DC filters will be different depending on whether DC filters for the final HVDC transmission line voltage are used from the beginning, or whether a series extension of capacitor units is made. Accordingly, it is necessary to clearly indicate this point.

IECNORM.COM : Click to view the full PDF of IEC TR 60919-1:2020 RLV

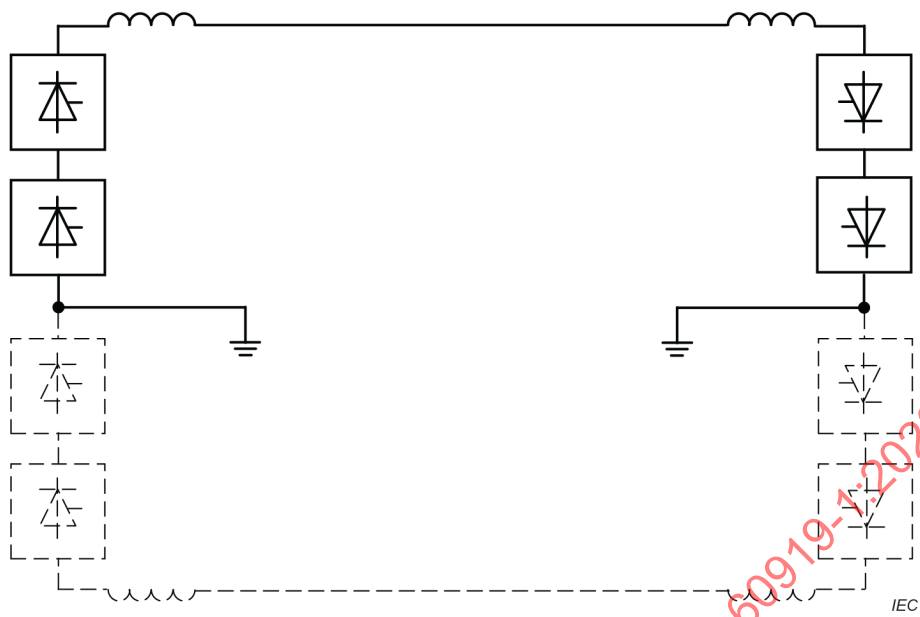

a) Monopolar to bipolar extension

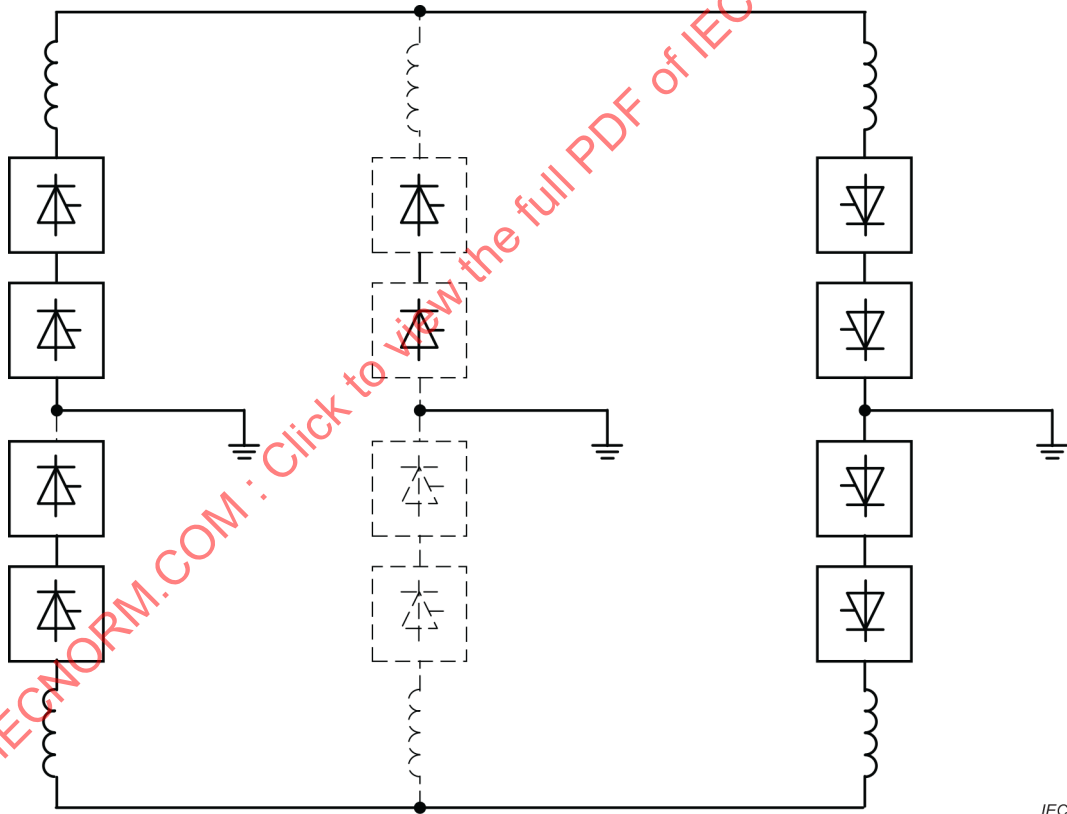

b) Multiterminal bridge extension

Figure 26 – Extension methods for HVDC systems

## Annex A (informative)

### Factors affecting reliability and availability of converter stations

#### A.1 Design and documentation

##### A.1.1 General

This annex explains various factors affecting the reliability and availability of an HVDC substation itself and does not provide an evaluation of reliability and availability. It can be noted that all may not be applicable to every HVDC substation and/or HVDC user.

The owner/user should specify such reliability and availability requirements as deemed applicable for the HVDC project. Without a mutual specific agreement between the supplier/manufacturer and the user/owner, this annex is for information and guidance purposes only.

The following subclauses are a compilation of suggested reliability and maintenance-driven design principles that have been specified for previous HVDC substation projects. The user may consider these in future converter station designs/specifications, as appropriate, in light of the operational mission, the surrounding electrical system, and the economics of the project.

##### A.1.2 General design principles

- a) For bipolar converters, the designer should pay special attention to avoiding bipolar forced outages and to keeping the duration of such outages to a minimum. This effort requires emphasis on such areas as subsystem and system testing, protection coordination, proper setting of protections, spare parts, and redundancy and separation of the subsystems of the two poles.
- b) Except where the user desires even more stringent design requirements, no single failure of equipment under rated operating conditions shall lead to more than a pole forced outage, and no combination of equipment failures within an HVDC converter pole should ever cause a forced outage extending beyond that pole. It may be noted that under some operating configurations (e.g. bipolar balanced operation with station earth), this may not be avoidable.
- c) Subject to the user's operating policy, no more than one pole at a time should need de-energisation as a precondition to any scheduled maintenance task. Furthermore, the HVDC substation design should require no more than one annual planned outage for routine maintenance of any individual piece of equipment.
- d) Wherever possible, converters should be designed to prevent false power reversals due to equipment failure, malfunction, or operator error.
- e) All control and protection systems should be designed so that no single failure in any of these systems causes a reduction in rated HVDC power transfer capacity.
- f) The control and protection equipment should be designed to cause no more than a defined number of discrete transient disturbances (with a minimum duration defined by the user) per pole per year; but excluding transient disturbances occurring while the HVDC controls and protections are responding, as designed, to problems originating in the adjacent AC system(s).
- g) Throughout the design of the HVDC substation, and particularly in the valve halls, care should be taken to identify and to prevent possible causes of fire, for example by use of fire retardant material. Where the possibility of fires cannot be eliminated entirely, provision should be made for the following conditions:
  - fire detection and alarming;

- human verification to avoid false tripping and unnecessary initiation of suppression measures, if applicable.
- h) The user may specify that the design and placement of auxiliary equipment (including their associated controls and protection) be such that a single equipment failure does not reduce rated HVDC power transfer capacity. Redundant cooling pumps, cooling fans, and heat exchangers would be one approach to meeting this requirement.

### A.1.3 More detailed design principles

The following features would improve performance when designed into the controls, protections, and similarly organized equipment.

- a) The least complex design capable of performing a required function.
- b) Components that are applied within their individual ratings and that have been proven in service or have undergone applicable accelerated life stress tests before commissioning.
- c) A burn-in period should be applied to all electronic components intended for application in valve groups and in control and protection equipment, before their incorporation into larger assemblies.
- d) Circuits using common components (to reduce the number of specific spares to stock).
- e) Design practices (such as surge protection, filtering, and interface buffers) to render sensitive components and circuits immune to damage and interference by induced voltages and currents in external cabling and cubicle wiring.
- f) Fail-safe and self-diagnostic designs.
- g) Redundant equipment and control cables, with automatic transfer facilities as appropriate.
- h) Physical separation of redundant cables and circuits to minimize the effect of fire, floods, and other such hazards.
- i) Designs that, in the event of component failures, transfer to a less complex operating mode.
- j) Equipment that may be maintained, repaired, and operated at the converter stations without the need for special operating and maintenance environments, test equipment, special tools, or complex operating sequences.
- k) Modular construction to permit rapid replacement of modules with failed components or subassemblies.
- l) Identification and separation of control switches for each converter and associated equipment to minimize operator errors.
- m) Designs that do not rely upon immediate operator actions to avoid equipment damage.

### A.1.4 Software design principles

Typically, all control and protection functions in HVDC substations are implemented as software. The overall reliability of an HVDC substation is directly impacted by the quality of this software.

- a) As with hardware, general quality assurance methods, principles, and organizations should be employed for software design and application. Organizational methods, audits, and certifications, as defined, for example, in the ISO 9000 family and in ISO/IEC/IEEE 90003:2018 in particular, apply here.
- b) Most of the general design principles mentioned in A.1.2, and most of the specific principles listed under A.1.3, are applicable to software as well. For example, the principle of minimum complexity should be observed to minimize the possibility of errors and to ease maintenance and repair. Use of proven standard function blocks (for control, logic, and communication) is recommended. These proven standard function blocks are configured (i.e. parameterized and combined) to provide the HVDC control and protection structure as needed. In order not to achieve robustness at the expense of jeopardizing

performance, this "function block" approach should be used only by well-trained, experienced personnel employing adequate hardware and software of familiar design.

- c) Software offers fundamental reliability-related advantages over hardware. These advantages should be used in all HVDC converter applications. For example, self-monitoring, self-diagnostics and fail-safe software should be applied prudently. Automatic documentation features should be used for diagrams, test reports, and manuals. All major control and protection functions should be included in the simulation tools used for the overall control and protection system design. The identical software combination should then be implemented and tested as part of the actual control and protection equipment.
- d) Awareness of the specific software-related problems and risks is necessary as well. Potential computer failures, auxiliary power outages, risk of unauthorized access, vulnerability to viruses, as well as the inevitable existence of (hidden) software faults should all be taken into consideration. Some of the remedies to be applied are use of proven and reliable computer, processor, and interface hardware; uninterruptible power supply; limited access; safely stored back-up software, etc.

### **A.1.5 RAM records**

Prior to commissioning, the user should establish a procedure to document all RAM-related events. Each event, whether scheduled or unpredicted, should be recorded with reference to all data relevant as to its cause and to its effect on RAM performance.

## **A.2 Operation**

### **A.2.1 Training**

#### **A.2.1.1 The role of training in HVDC substation RAM**

Trained staff does make a difference to the total reliability/availability of an HVDC substation. At the earliest stage (tender and contract preparation), the staffing requirements of a station should be outlined.

#### **A.2.1.2 Training courses**

In general, training should be given to operation and maintenance personnel and should start, if possible, before the factory acceptance tests begin for the control and protection system.

A training program may start with a classroom orientation, which is then completed in time for the start of equipment pre-commissioning. A training course may be divided into four parts. They are as follows.

- a) General lectures on the system and the equipment – their purposes, functions, methods of use, and control and protection principles – with appropriate texts.
- b) Specific lectures on operation and maintenance, given separately, even if attended by the same personnel. All items of equipment, whether special or conventional, should be covered by both courses.
- c) Experience gained from participation in installation, testing, pre-commissioning, and commissioning, after these lectures have been assimilated. If possible, the testing of converter valves and of controls should be witnessed by some trainees.

Here, too, video recording is highly advisable – particularly for relatively uncommon events such as the replacement of a converter transformer, smoothing reactor, or thyristor.

- d) Practical exercises to ensure that trainees are able to operate the station in a safe and efficient manner.

## **A.2.2 Maintenance programs affecting reliability**

### **A.2.2.1 Basics**

The goal of maintenance planning is to reach an optimum balance between the total expense of scheduled outages and the frequency of forced outages. Maintenance may be as follows:

- a) preventive: to maintain or improve the equipment's ability to operate;
- b) predictive: to ward off a perceived imminent danger of forced outage;
- c) corrective: to clear a forced outage.

Maintenance tasks, having intervals of less than one year, may be online tasks, especially when the system design includes redundancy. These tasks may be planned and executed as on-line maintenance throughout the year.

Most, but not all, maintenance tasks having intervals equal to or longer than one year are (subsystem or component) offline tasks. Depending on whether a redundant subsystem or component exists and on whether it is accessible when the system is online, its maintenance is either made part of the (system) online maintenance or declared a (system) offline task. These offline tasks are grouped on an annual basis and performed during an annual scheduled outage.

### **A.2.2.2 Designing systems and specifying equipment for optimum maintainability**

A predictive RAM calculation should, among other goals, include design targets related to maintenance. As the design and maintenance planning progresses, the RAM calculation might have to be repeated.

### **A.2.2.3 Planning maintenance programs**

Maintenance planning may be based on the methodology of reliability-centred maintenance (RCM).

RCM focuses on the prioritization of the tasks according to their perceived necessity, instead of just performing the work according to, for instance, the manufacturer's maintenance manuals. As a typical result, identical components in different locations might have different maintenance schedules, after considering criteria such as the following:

- function within the system as a whole;
- probability of failure, also considering the stress conditions;
- availability of early failure warning;
- impact of failure on system performance [failure mode and effect analysis (FMEA) is often used to analyse this impact];
- redundancy;
- measurable ageing and wear on equipment;
- identifying which maintenance tasks are indispensable;
- determining which further maintenance activities would improve reliability by reducing the exposure to failures, delaying their occurrence, facilitating their detection, etc.;
- tutorials, reports, and other types of literature on RCM that are available.

After the RCM analysis, the HVDC user should consider further factors in order to refine the overall maintenance plan. These factors are as follows:

- vendor warranty requirements;
- applicable standards requirements;
- other contractual requirements;

- liability and insurance requirements;
- economics.

A special feature of HVDC bipole systems that are able to transmit 50 % (or more) energy on either pole and 100 % energy on both poles is that one pole may undergo a scheduled outage while the other pole is in operation (provided the equipment layout and the power network allow this option). In such cases, the user might divide the annual scheduled outage into three parts: one pole outage for each pole, and a scheduled bipole outage (for any equipment common to both poles, irrespective of the design goals of A.1.2).

Finally, planning offline maintenance on an annual basis does not mean that all annual scheduled outage plans are identical, even if the equipment list remains unchanged, for the following two main reasons.

- a) Tasks with prescribed intervals equal to or longer than two years are not carried out year by year.
- b) Although constant component failure rates are assumed, failure rates tend to change with time according to the "bathtub curve", and as a function of the mechanical and/or electrical stresses to which the components are subjected.

### **A.2.3 Spare parts**

#### **A.2.3.1 Types of spare parts**

##### **A.2.3.1.1 Consumables**

Consumables are used continuously, so small numbers are kept on hand or ordered just before scheduled maintenance periods. They are easily replaced, sources are plentiful, and they are not usually included in the original contractual inventory.

##### **A.2.3.1.2 Long-term spares**

Long-term spares are needed for the entire life of the converter station. They may be classified into two groups, as follows.

- a) Parts needed only at long intervals (e.g., once in five years). The user should check the availability of these items frequently, and they may have to be included in the station's inventory if they become difficult to procure.
- b) Emergency items needed to recover from a forced outage. There is no way to guarantee the failure rate or the availability of the replacement part at the time of the failure.

Early in the life of the project, the user should identify long lead-time items available from relatively few sources.

##### **A.2.3.2 Evaluation**

Consumables and maintenance items are not much of a problem, in that the replacement rate is known. The real issue in spare parts inventory is the emergency item. To have every possible needed emergency part would require having almost a complete spare converter station in the inventory. In general, the number of spare parts kept in the station's inventory is proportional to the cost of the station's downtime and is based upon field experience with similar equipment or apparatus. The user should, therefore, decide what items need to be kept on hand and what may be supplied by the manufacturer by considering the following:

- a) items with an expected high failure rate,
- b) items with a long lead time for replacement,
- c) items critical to the operation of the station,
- d) items not readily available from the manufacturer or no longer in production,

e) procurement and warehousing costs.

Redundancy is, in effect, an "in-service" spare part and also affects the spare part strategy.

### A.2.3.3 A typical spare parts list

This list is intended to give the user some general examples of what other HVDC projects have kept in stock. The list shall be specifically agreed between supplier and purchaser for each contract separately.

Spare parts may include the following:

- a) converter transformers – especially when single-phase transformers are used;
  - converter transformer components;
  - bushings;
  - pumps with motor;
  - fans with motor;
- b) reactors;
  - smoothing reactor (if the smoothing reactor is oil-filled, then there may be a need for components similar to those for the transformer);
  - shunt (power factor) reactor (if the shunt reactor is oil-filled, then there may be a need for components similar to those for the transformer);
  - air-cored smoothing reactor and filter reactor (one spare coil may suffice for reactors having several coils);
  - electrode line reactor;
- c) converter valves;
  - thyristors;
  - components of the damping circuit, and voltage divider (e.g., capacitors, resistors);
  - valve reactor;
  - electronic circuit boards for valve electronics and valve base electronics (VBE);
  - fibre-optic cables;
- d) DC wall bushings;
  - AC and DC arresters (some multi-column arresters might have energized spare columns instead of complete spare arresters);
- e) AC circuit breaker and load-break switch accessories;
  - closing and tripping coils;
  - closing and tripping mechanisms;
  - control rods;
  - arcing contacts (for tripping and closing);
- f) voltage and current measurement devices;
  - capacitive voltage transformers;
  - DC voltage dividers;
  - potential transformers;
  - current transformers;
  - DC current transducers;
- g) power factor bank and harmonic filter equipment (besides reactors);
  - shunt capacitors (capacitor cans and support insulators, not complete banks);
  - resistors (when a resistor consists of several modules, one spare module may suffice);

- h) other DC side equipment;
  - DC switchgear;
  - neutral bus capacitors (capacitor cans and support insulators, not complete banks);
  - electrode line capacitors (capacitor cans and support insulators, not complete banks);
- i) control, protection, and metering equipment;
  - valve control (electronic boards);
  - DC control (electronic boards);
  - fault monitoring;
- j) station service and auxiliary power equipment;
  - low-voltage circuit breakers and transfer switches;
  - fuses;
  - low-voltage arresters;
  - battery charger accessories;
  - uninterruptible power supply accessories;
- k) valve cooling equipment;
  - fan with motor;
  - pump with motor;
  - mechanical valves;
  - filters for cooling medium.

IECNORM.COM : Click to view the full PDF of IEC TR 60919-1:2020 RLV

## Bibliography

IEC 60146-1-1, *Semiconductor converters – General requirements and line commutated converters – Part 1-1: Specification of basic requirements*

IEC TR 60146-1-2, *Semiconductor converters – General requirements and line commutated converters – Part 1-2: Application guidelines*

IEC 60146-1-3, *Semiconductor converters – General requirements and line commutated converters – Part 1-3: Transformers and reactors*

IEC 60146-2:~~1999~~, *Semiconductor converters – Part 2: Self-commutated semiconductor converters including direct DC converters*

IEC/TR 60146-6:~~1992~~, *Semiconductor converters – Part 6: Application guide for the protection of semiconductor converters against overcurrent by fuses*

IEC 60700-1:~~1998~~, *Thyristor valves for high-voltage direct current (HVDC) power transmission – Part 1: Electrical testing<sup>4</sup>*

IEC TR 60919-2, *Performance of high-voltage direct current (HVDC) systems with line-commutated converters – Part 2: Faults and switching*

IEC TR 60919-3, *Performance of high-voltage direct current (HVDC) systems with line-commutated converters – Part 3: Dynamic conditions*

IEC 61148:~~1992~~, *Terminal markings for valve device stacks and assemblies and for power ~~converter~~ conversion equipment*

IEC 61803, *Determination of power losses in high-voltage direct current (HVDC) converter stations with line commutated converters*

IEC TR 62001 (all parts), *High-voltage direct current (HVDC) systems – ~~Guidebook~~ Guidance to the specification and design evaluation of AC filters*

IEC TR 62672, *Reliability and availability evaluation of HVDC systems*

CISPR 11, *Industrial, scientific and medical equipment – Radio-frequency disturbance characteristics – Limits and methods of measurement*

CISPR 16 (all parts), *Specification for radio disturbance and immunity measuring apparatus and methods*

CISPR 18 (all parts), *Radio interference characteristics of overhead power lines and high-voltage equipment*

~~CIGRE Brochure 346, Protocol for reporting the operational performance of HVDC transmission systems~~

ISO/IEC TS 30103:2015, *Software and Systems Engineering – Lifecycle Processes – Framework for Product Quality Achievement*

---

<sup>4</sup> ~~There exists a consolidated edition 1.2 (2008) that consists of edition 1 (1998) and its amendments 1 (2003) and 2 (2008).~~

ISO/IEC/IEEE 90003:2018, *Software engineering – Guidelines for the application of ISO 9001:2015 to computer software*

ISO 1996-1, *Acoustics – Description, measurement and assessment of environmental noise – Part 1: Basic quantities and assessment procedures*

ISO 9001:2015, *Quality management systems — Requirements*

ISO 10006, *Quality management—Guidelines for quality management in projects*

ISO/IEC 31010:2009, *Risk management – Risk assessment techniques*

ISO 50001:2018, *Energy management systems – Requirements with guidance for use*

EI Publication 60-68:~~1960~~, *The telephone influence factor of supply system voltages and currents.*

---

IECNORM.COM : Click to view the full PDF of IEC TR 60919-1:2020 RLV

# TECHNICAL REPORT



**Performance of high-voltage direct current (HVDC) systems with  
line-commutated converters –  
Part 1: Steady-state conditions**

IECNORM.COM : Click to view the full PDF of IEC TR 60919-1:2020 RLV

## CONTENTS

FOREWORD.....	8
INTRODUCTION.....	10
1 Scope.....	11
2 Normative references .....	12
3 Terms and definitions .....	12
4 Types of HVDC systems .....	12
4.1 General.....	12
4.2 HVDC back-to-back system .....	12
4.3 Monopolar HVDC system with earth return.....	13
4.4 Monopolar HVDC system with metallic return.....	16
4.5 Bipolar earth return HVDC system .....	17
4.6 Bipolar HVDC system with metallic return .....	20
4.7 Two 12-pulse groups per pole.....	21
4.8 Converter transformer arrangements.....	24
4.9 DC switching considerations .....	25
4.10 Series-capacitor-compensated HVDC systems.....	28
4.11 LCC/VSC hybrid bipolar system .....	32
5 Environment information.....	33
6 Rated power, current and voltage .....	36
6.1 Rated power .....	36
6.1.1 General .....	36
6.1.2 Rated power of an HVDC system with transmission line .....	36
6.1.3 Rated power of an HVDC back-to-back system.....	36
6.1.4 Direction of power flow.....	37
6.2 Rated current.....	37
6.3 Rated voltage .....	37
7 Overload and equipment capability.....	37
7.1 Overload.....	37
7.2 Equipment capability.....	38
7.2.1 General .....	38
7.2.2 Converter valve capability.....	38
7.2.3 Capability of oil-cooled transformers and reactors .....	39
7.2.4 AC harmonic filter and reactive power compensation equipment capability .....	39
7.2.5 Switchgear and buswork capability .....	39
8 Minimum power transfer and no-load stand-by state .....	39
8.1 General.....	39
8.2 Minimum current.....	39
8.3 Reduced direct voltage operation.....	40
8.4 No-load stand-by state.....	40
8.4.1 General .....	40
8.4.2 Converter transformers – No-load stand-by .....	40
8.4.3 Converter valves – No-load stand-by .....	40
8.4.4 AC filters and reactive compensation – No-load stand-by .....	41
8.4.5 DC reactors and DC filters – No-load stand-by .....	41

8.4.6	Auxiliary power system – No-load stand-by	41
8.4.7	Control and protection – No-load stand-by	41
9	AC system	41
9.1	General	41
9.2	AC voltage	41
9.2.1	Rated AC voltage	41
9.2.2	Steady-state voltage range	41
9.2.3	Negative sequence voltage	42
9.3	Frequency	42
9.3.1	Rated frequency	42
9.3.2	Steady-state frequency range	43
9.3.3	Short-term frequency variation	43
9.3.4	Frequency variation during emergency	43
9.4	System impedance at fundamental frequency	43
9.5	System impedance at harmonic frequencies	43
9.6	Positive and zero-sequence surge impedance	43
9.7	Other sources of harmonics	44
9.8	Subsynchronous torsional interaction (SSTI)	44
10	Reactive power	44
10.1	General	44
10.2	Conventional HVDC systems	44
10.3	Series capacitor compensated HVDC schemes	46
10.4	Converter reactive power consumption	46
10.5	Reactive power balance with the AC system	46
10.6	Reactive power supply	46
10.7	Maximum size of switchable VAR banks	47
11	HVDC transmission line, earth electrode line and earth electrode	47
11.1	General	47
11.2	Overhead line(s)	47
11.2.1	General	47
11.2.2	Electrical parameters	47
11.3	Cable line(s)	48
11.3.1	General	48
11.3.2	Electrical parameters	48
11.4	Earth electrode line	49
11.5	Earth electrode	49
12	Reliability	49
12.1	General	49
12.2	Outage	49
12.2.1	General	49
12.2.2	Scheduled outage	49
12.2.3	Forced outage	49
12.3	Capacity	50
12.3.1	General	50
12.3.2	Maximum continuous capacity $P_m$	50
12.3.3	Outage capacity $P_o$	50
12.3.4	Outage derating factor (ODF)	50
12.4	Outage duration terms	50

12.4.1	Actual outage duration (AOD)	50
12.4.2	Equivalent outage duration (EOD)	50
12.4.3	Period hours (PH)	50
12.4.4	Actual outage hours (AOH)	51
12.4.5	Equivalent outage hours (EOH)	51
12.5	Energy unavailability (EU)	51
12.5.1	General	51
12.5.2	Forced energy unavailability (FEU)	51
12.5.3	Scheduled energy unavailability (SEU)	52
12.6	Energy availability (EA)	52
12.7	Maximum permitted number of forced outages	52
12.8	Statistical probability of outages	52
12.8.1	Component faults	52
12.8.2	External faults	52
13	HVDC control	52
13.1	Control objectives	52
13.2	Control structure	53
13.2.1	General	53
13.2.2	Converter unit firing control	53
13.2.3	Pole control	54
13.2.4	HVDC substation control	56
13.2.5	Master control	58
13.3	Control order settings	58
13.4	Current limits	58
13.5	Control circuit redundancy	59
13.6	Protection system	59
13.7	Measurements	59
14	Telecommunication	60
14.1	Types of telecommunication links	60
14.2	Telephone	60
14.3	Power line carrier (PLC)	60
14.4	Microwave	61
14.5	Radio link	61
14.6	Optical fibre telecommunication	61
14.7	Classification of data to be transmitted	61
14.8	Fast response telecommunication	62
14.9	Reliability	62
15	Auxiliary power supplies	63
15.1	General	63
15.2	Reliability and load classification	63
15.3	AC auxiliary supplies	64
15.4	Batteries and uninterruptible power supplies (UPS)	64
15.5	Emergency supply	65
16	Audible noise	65
16.1	General	65
16.2	Public nuisance	65
16.2.1	General	65
16.2.2	Valves and valve coolers	66

16.2.3	Converter transformers .....	66
16.2.4	DC reactors .....	66
16.2.5	AC filter reactors .....	66
16.3	Noise in working areas .....	66
17	Harmonic interference – AC .....	67
17.1	AC side harmonic generation .....	67
17.2	Filters .....	67
17.3	Interference disturbance criteria .....	70
17.4	Levels for interference .....	71
17.5	Filter performance .....	72
18	Harmonic interference – DC .....	72
18.1	DC side interference .....	72
18.1.1	Harmonic currents in HVDC transmission line .....	72
18.1.2	Characteristic and non-characteristic harmonics .....	72
18.1.3	Groups of harmonics .....	73
18.1.4	Calculation of harmonic currents .....	73
18.1.5	Calculation of induced voltages .....	73
18.1.6	Personnel safety .....	73
18.1.7	DC filters .....	73
18.2	DC filter performance .....	74
18.2.1	Requirements for voice communication circuits .....	74
18.2.2	Levels of interference .....	74
18.2.3	Safety .....	74
18.3	Specification requirements .....	75
18.3.1	Economic level of filtering .....	75
18.3.2	General criteria .....	76
18.3.3	Factors to be taken into account for calculations .....	76
18.3.4	Calculation of currents .....	77
19	Power line carrier interference (PLC) .....	77
19.1	General .....	77
19.2	Performance specification .....	78
20	Radio frequency interference .....	79
20.1	General .....	79
20.2	RFI from HVDC systems .....	80
20.2.1	RFI sources .....	80
20.2.2	RFI propagation .....	80
20.2.3	RFI characteristics .....	80
20.3	RFI performance specification .....	81
20.3.1	RFI risk assessment .....	81
20.3.2	Specification RFI limit and its verification .....	81
20.3.3	Design aspects .....	82
21	Power losses .....	82
21.1	General .....	82
21.2	Main contributing sources .....	83
21.2.1	General .....	83
21.2.2	AC filters and reactive power compensation .....	83
21.2.3	Converter bridges .....	83
21.2.4	Converter transformer .....	83

21.2.5	DC reactor .....	83
21.2.6	DC filter .....	84
21.2.7	Auxiliary equipment .....	84
21.2.8	Other components .....	84
22	Provision for extensions to the HVDC systems .....	84
22.1	General.....	84
22.2	Specification for extensions .....	84
Annex A	(informative) Factors affecting reliability and availability of converter stations .....	87
A.1	Design and documentation.....	87
A.1.1	General .....	87
A.1.2	General design principles .....	87
A.1.3	More detailed design principles .....	88
A.1.4	Software design principles.....	88
A.1.5	RAM records.....	89
A.2	Operation.....	89
A.2.1	Training .....	89
A.2.2	Maintenance programs affecting reliability .....	90
A.2.3	Spare parts.....	91
Bibliography	.....	94
Figure 1	– Twelve-pulse converter unit .....	11
Figure 2	– Examples of back-to-back HVDC systems.....	13
Figure 3	– Monopolar HVDC system with earth return .....	14
Figure 4	– Two 12-pulse units in series.....	15
Figure 5	– Two 12-pulse units in parallel.....	16
Figure 6	– Monopolar HVDC system with metallic return .....	17
Figure 7	– Bipolar system .....	18
Figure 8	– Metallic return operation of the unfaulted pole in a bipolar system.....	19
Figure 9	– Bipolar HVDC system with metallic return .....	21
Figure 10	– Bipolar system with two 12-pulse units in series per pole .....	23
Figure 11	– Bipolar system with two 12-pulse units in parallel per pole .....	24
Figure 12	– DC switching of line conductors .....	26
Figure 13	– DC switching of converter poles .....	27
Figure 14	– DC switching – Overhead line to cable .....	28
Figure 15	– DC switching – Two bipolar converters and lines .....	29
Figure 16	– DC switching – Intermediate.....	30
Figure 17	– Capacitor commutated converter configurations .....	31
Figure 18	– LCC/VSC hybrid bipolar system .....	33
Figure 19	– Variations of reactive power $Q$ with active power $P$ of an HVDC converter .....	45
Figure 20	– Control hierarchy for HVDC/UHVDC system.....	55
Figure 21	– Converter voltage-current characteristic .....	57
Figure 22	– Examples of AC filter connections for a bipole HVDC system .....	68
Figure 23	– Circuit diagrams for different filter types .....	69
Figure 24	– RY COM interference meter results averaged – Typical plot of converter interference levels on the DC line .....	79

Figure 25 – Recommended measurement procedure with definition of measuring point ..... 82

Figure 26 – Extension methods for HVDC systems ..... 86

Table 1 – Information supplied for HVDC substation ..... 34

Table 2 – Performance parameters for voice communication circuits: Subscribers and trunk circuits ..... 75

*IECNORM.COM : Click to view the full PDF of IEC TR 60919-1:2020 RLV*

## INTERNATIONAL ELECTROTECHNICAL COMMISSION

**PERFORMANCE OF HIGH-VOLTAGE DIRECT CURRENT  
(HVDC) SYSTEMS WITH LINE-COMMUTATED CONVERTERS –****Part 1: Steady-state conditions**

## FOREWORD

- 1) The International Electrotechnical Commission (IEC) is a worldwide organization for standardization comprising all national electrotechnical committees (IEC National Committees). The object of IEC is to promote international co-operation on all questions concerning standardization in the electrical and electronic fields. To this end and in addition to other activities, IEC publishes International Standards, Technical Specifications, Technical Reports, Publicly Available Specifications (PAS) and Guides (hereafter referred to as "IEC Publication(s)"). Their preparation is entrusted to technical committees; any IEC National Committee interested in the subject dealt with may participate in this preparatory work. International, governmental and non-governmental organizations liaising with the IEC also participate in this preparation. IEC collaborates closely with the International Organization for Standardization (ISO) in accordance with conditions determined by agreement between the two organizations.
- 2) The formal decisions or agreements of IEC on technical matters express, as nearly as possible, an international consensus of opinion on the relevant subjects since each technical committee has representation from all interested IEC National Committees.
- 3) IEC Publications have the form of recommendations for international use and are accepted by IEC National Committees in that sense. While all reasonable efforts are made to ensure that the technical content of IEC Publications is accurate, IEC cannot be held responsible for the way in which they are used or for any misinterpretation by any end user.
- 4) In order to promote international uniformity, IEC National Committees undertake to apply IEC Publications transparently to the maximum extent possible in their national and regional publications. Any divergence between any IEC Publication and the corresponding national or regional publication shall be clearly indicated in the latter.
- 5) IEC itself does not provide any attestation of conformity. Independent certification bodies provide conformity assessment services and, in some areas, access to IEC marks of conformity. IEC is not responsible for any services carried out by independent certification bodies.
- 6) All users should ensure that they have the latest edition of this publication.
- 7) No liability shall attach to IEC or its directors, employees, servants or agents including individual experts and members of its technical committees and IEC National Committees for any personal injury, property damage or other damage of any nature whatsoever, whether direct or indirect, or for costs (including legal fees) and expenses arising out of the publication, use of, or reliance upon, this IEC Publication or any other IEC Publications.
- 8) Attention is drawn to the Normative references cited in this publication. Use of the referenced publications is indispensable for the correct application of this publication.
- 9) Attention is drawn to the possibility that some of the elements of this IEC Publication may be the subject of patent rights. IEC shall not be held responsible for identifying any or all such patent rights.

The main task of IEC technical committees is to prepare International Standards. However, a technical committee may propose the publication of a technical report when it has collected data of a different kind from that which is normally published as an International Standard, for example "state of the art".

IEC TR 60919-1, which is a technical report, has been prepared by subcommittee 22F: Power electronics for electrical transmission and distribution systems, of IEC technical committee 22: Power electronic systems and equipment.

This fourth edition cancels and replaces the third edition, published in 2010, Amendment 1:2013 and Amendment 2:2017. This edition constitutes a technical revision.

This edition includes the following significant technical changes with respect to the previous edition:

- a) Figure 8 and Figure 20 have been updated, a new Figure 18 "LCC/VSC hybrid bipolar system" has been added;
- b) the HVDC system control objectives have been supplemented;
- c) additional explanations regarding the HVDC system control structure have been given;
- d) a new subclause 13.6 on HVDC system protection has been added.

The text of this Technical Report is based on the following documents:

Draft TR	Report on voting
22F/535/DTR	22F/549A/RVDTR

Full information on the voting for the approval of this Technical Report can be found in the report on voting indicated in the above table.

This document has been drafted in accordance with the ISO/IEC Directives, Part 2.

A list of all parts of the IEC 60919 series, published under the general title *Performance of high-voltage direct current (HVDC) systems with line-commutated converters*, can be found on the IEC website.

The committee has decided that the contents of this document will remain unchanged until the stability date indicated on the IEC website under "<http://webstore.iec.ch>" in the data related to the specific document. At this date, the document will be

- reconfirmed,
- withdrawn,
- replaced by a revised edition, or
- amended.

**IMPORTANT – The 'colour inside' logo on the cover page of this publication indicates that it contains colours which are considered to be useful for the correct understanding of its contents. Users should therefore print this document using a colour printer.**

## INTRODUCTION

The difference between system performance specifications and equipment design specifications for individual components of a system is realized. Frequently, performance specifications are prepared as a single package for the two HVDC substations in a particular system. Alternatively, some parts of the HVDC system can be separately specified and purchased. In such cases, due consideration is given to coordination of each part with the overall HVDC system performance objectives and to ensuring that the interface of each with the system is clearly defined. Typical of such parts, listed in the appropriate order of relative ease for separate treatment and interface definition, are:

- a) DC line, electrode line and earth electrode;
- b) telecommunication system;
- c) converter building, foundations and other civil engineering work;
- d) reactive power supply including AC shunt capacitor banks, shunt reactors, synchronous and static reactive power (var) compensators;
- e) AC switchgear;
- f) DC switchgear;
- g) auxiliary systems;
- h) AC filters;
- i) DC filters;
- j) DC reactors;
- k) converter transformers;
- l) surge arresters;
- m) series commutation capacitors;
- n) valves and their ancillaries;
- o) control and protection systems.

NOTE The last four items are the most difficult to separate, and, in fact, separation of these four can be inadvisable.

Clause 4 to Clause 22 of this document set out a complete steady-state performance specification for an HVDC system.

Since the equipment items are usually separately specified and purchased, the HVDC transmission line, earth electrode line and earth electrode (see Clause 11) are included only because of their influence on the HVDC system performance.

For the purpose of this document, an HVDC substation is assumed to consist of one or more converter units installed in a single location together with buildings, reactors, filters, reactive power supply, control, monitoring, protective, measuring and auxiliary equipment. While there is no discussion of AC switching substations in this document, AC filters and reactive power sources are included, although they can be connected to an AC bus separate from the HVDC substation, as discussed in Clause 17.

# PERFORMANCE OF HIGH-VOLTAGE DIRECT CURRENT (HVDC) SYSTEMS WITH LINE-COMMUTATED CONVERTERS –

## Part 1: Steady-state conditions

### 1 Scope

This part of IEC 60919 provides general guidance on the steady-state performance requirements of high-voltage direct current (HVDC) systems. It concerns the steady-state performance of two-terminal HVDC systems utilizing 12-pulse converter units comprised of three-phase bridge (double-way) connections (see Figure 1), but it does not cover multi-terminal HVDC transmission systems. Both terminals are assumed to use thyristor valves as the main semiconductor valves and to have power flow capability in both directions. Diode valves are not considered in this document.

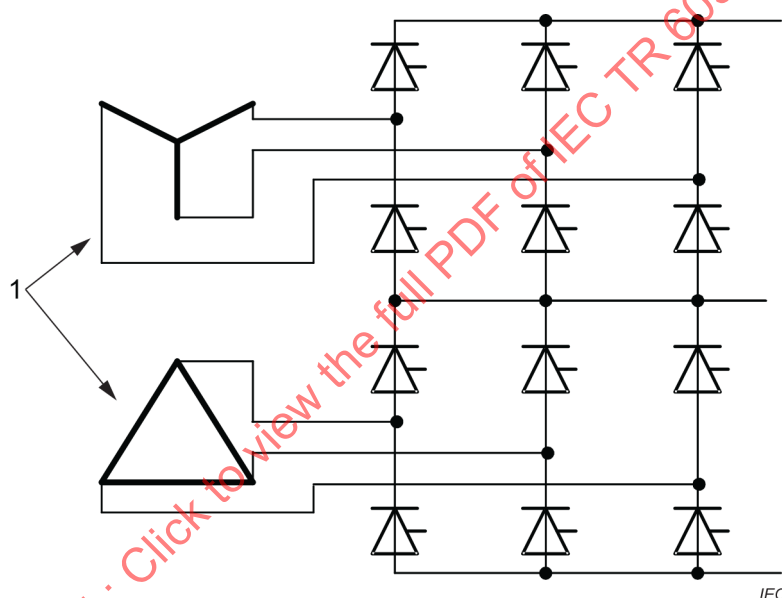

#### Key

1 Transformer valve windings

**Figure 1 – Twelve-pulse converter unit**

Only line-commutated converters are covered in this document, which includes capacitor commutated converter circuit configurations. General aspects of semiconductor line-commutated converters are given in IEC 60146-1-1, IEC TR 60146-1-2 and IEC 60146-1-3. Voltage-sourced converters are not considered.

The distinction is made between system performance specifications and equipment design specifications for individual components of a system. Equipment specifications and testing requirements are not defined in this document. Also excluded from this document are detailed seismic performance requirements. In addition, because there are many variations between different possible HVDC systems, this document does not consider these in detail; consequently, it is not used directly as a specification for a particular project, but rather to provide the basis for an appropriate specification tailored to fit actual system requirements.

This document, which covers steady-state performance, is followed by the additional documents of IEC TR 60919-2 on faults and switching as well as IEC TR 60919-3 on dynamic

conditions. All three aspects are considered when preparing two-terminal HVDC system specifications.

## 2 Normative references

The following documents are referred to in the text in such a way that some or all of their content constitutes requirements of this document. For dated references, only the edition cited applies. For undated references, the latest edition of the referenced document (including any amendments) applies.

IEC 60633, *High-voltage direct current (HVDC) transmission – Vocabulary*

CIGRÉ Technical Brochure (TB) No. 391:2009, *Guide for measurement of radio frequency interference from HV and MV substations. Disturbance propagation, characteristics of disturbance sources, measurement techniques, conversion methodologies and limits*

## 3 Terms and definitions

For the purposes of this document, the terms and definitions given in IEC 60633 apply.

ISO and IEC maintain terminological databases for use in standardization at the following addresses:

- IEC Electropedia: available at <http://www.electropedia.org/>
- ISO Online browsing platform: available at <http://www.iso.org/obp>

## 4 Types of HVDC systems

### 4.1 General

This part of the specification should include the following basic data:

- a) general information on the location of the HVDC substations and the purpose of the project;
- b) type of system needed, including a simple one-line diagram;
- c) number of 12-pulse converter units;
- d) pertinent information derived from the discussion in Clause 4.

Generally, in studies of projects of the types discussed in this document, economic considerations should take into account the capital costs, the cost of losses, cost of outages and other expected annual expenses.

In terms of the type of system, the "capacitor-commutated converter (CCC)" and "controlled series capacitor converter (CSCC)" technology may be suitable alternatives to a conventional HVDC scheme. These are described in 4.10.

### 4.2 HVDC back-to-back system

In this arrangement there is no DC transmission line and both converters are located at one site. The valves for both converters may be located in one valve hall, or even in one integrated structure or separately as outdoor valves. Similarly, many other items for the two converters, such as the control system, cooling equipment, auxiliary system, etc., may be located in one area or even integrated in layout into configurations common to the two converters. Circuit configurations may vary. Examples are given in Figure 2. The performance and economics of these configurations differ and should be evaluated. DC filters are not needed.

The voltage and current ratings for a given power rating should be optimized to achieve the lowest system cost, including the evaluated cost of losses. Ordinarily, the user does not need to specify the direct voltage and current ratings, unless there are specific reasons to do so, for example, for compatibility with an already existing station, to provide for a future extension or for some other reason. Economics dictate that each converter will usually be a 12-pulse converter unit, however it is not mandatory. Where operating criteria require that the loss of one converter unit will not cause loss of full power capability, large HVDC substations could be comprised of two or more back-to-back systems. For this, some of the equipment of the back-to-back systems can, for economic reasons, be located in the same area or even physically integrated, but events which could cause a failure of equipment required by all back-to-back systems need to be carefully considered and preventive measures taken where appropriate.

### 4.3 Monopolar HVDC system with earth return

Cost considerations often lead to the adoption of a monopolar HVDC system with earth return (Figure 3), particularly for cable transmission which may be expensive.

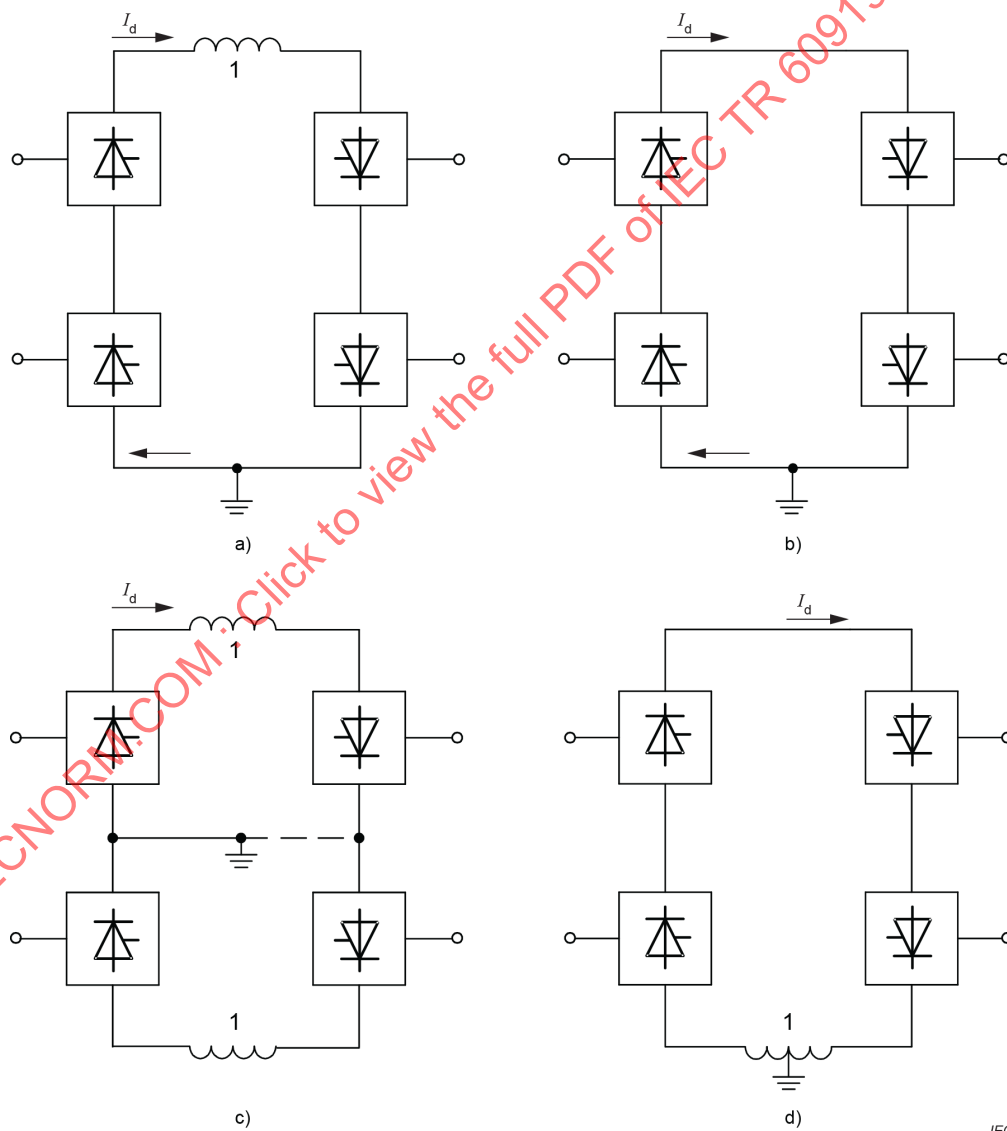

#### Key

1 DC reactor

Figure 2 – Examples of back-to-back HVDC systems

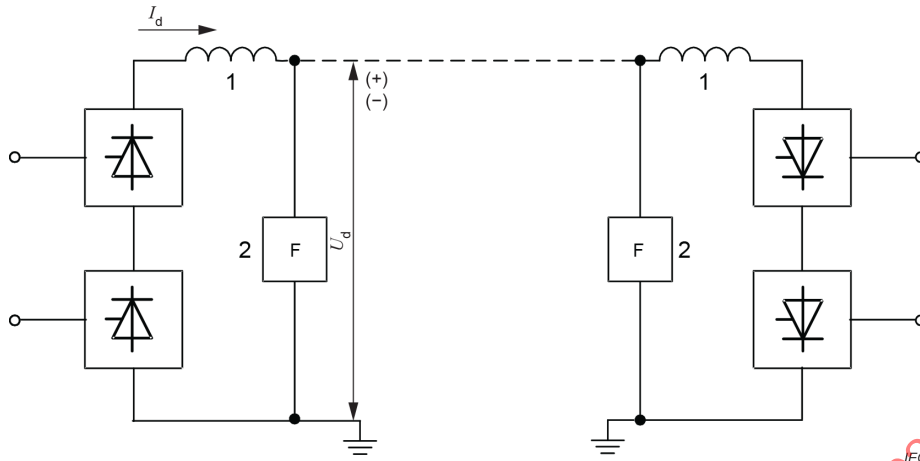

**Key**

- 1 DC reactor
- 2 DC filters

**Figure 3 – Monopolar HVDC system with earth return**

The monopolar earth return configuration might also be the first stage in the development of a bipolar scheme. Monopolar arrangements may include one or more 12-pulse units in series or in parallel at the ends of the HVDC transmission (Figure 4 and Figure 5). More than one 12-pulse unit can be used for the following purposes:

- a) to ensure partial transmission capacity during converter unit outages;
- b) to complete the project in stages;
- c) because of the physical limitations of transformer transport.

This arrangement requires one or more DC reactors at each end of the HVDC overhead line or cable; these are usually located on the high-voltage side.

If the line is overhead, DC filters are likely to be needed at each end (see Clause 18). It also requires an earth electrode line and a continuously operable earth electrode at the two ends of the transmission which involves consideration of issues such as corrosion, magnetic field effects, etc.

IECNORM.COM : Click to view the full PDF of IEC TR 60919-1:2020 RLV

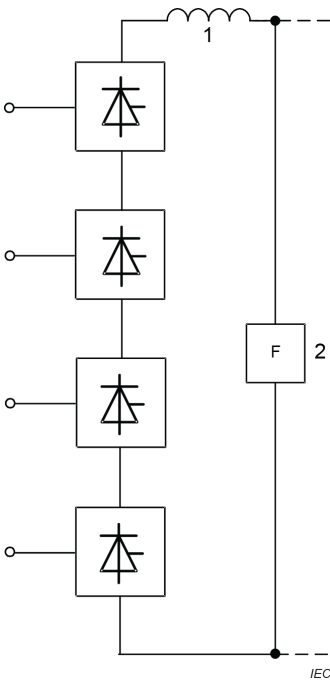

**Key**

- 1 DC reactor
- 2 DC filter

**Figure 4 – Two 12-pulse units in series**

IECNORM.COM : Click to view the full PDF of IEC TR 60919-1:2020 RLV

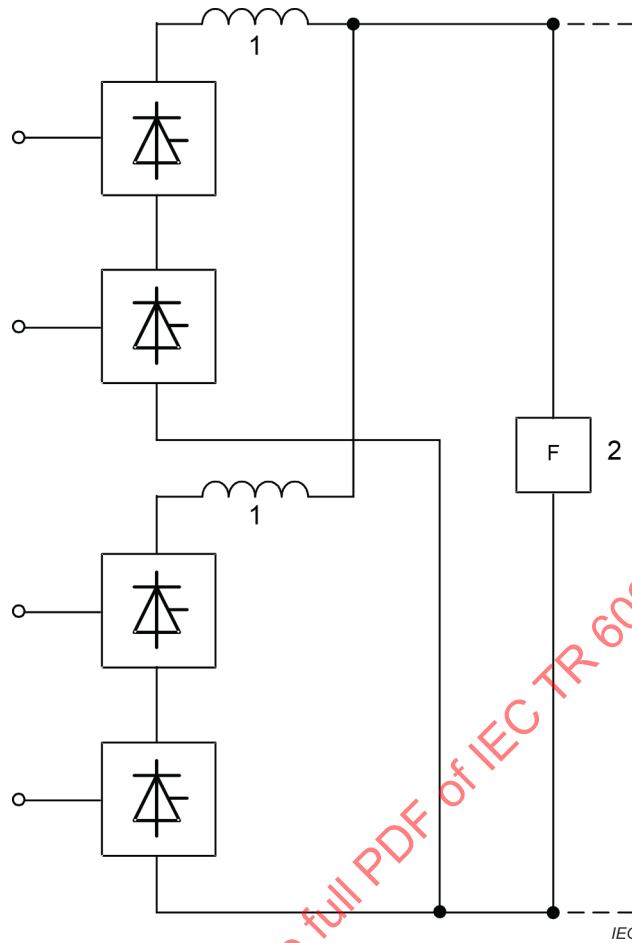

**Key**

- 1 DC reactor
- 2 DC filter

**Figure 5 – Two 12-pulse units in parallel**

**4.4 Monopolar HVDC system with metallic return**

The configuration as illustrated in Figure 6 will generally be used for the following purposes:

- a) as the first stage in the construction of a bipolar system and if long-term flow of earth current is not desirable during the interim period, or
- b) if the transmission line length is short enough to make it uneconomic and undesirable to build earth electrode lines and earth electrodes, or
- c) if the earth resistivity is high enough to impose an unacceptable economic penalty, or
- d) if long-term flow of earth current is unacceptable because of environmental and safety requirements.

This configuration utilizes one high-voltage and one low-voltage conductor. The neutral is connected at one of the two HVDC substations to its station earth or, alternatively, to the associated earth electrode. The other HVDC substation neutral is connected to its station earth through a capacitor or an arrester or both.

DC reactors are needed at both ends of the high-voltage conductor. However, the DC reactor may be located on the earth side if the resulting performance is acceptable. However, the DC reactors may be divided into two parts and located on the high-voltage side and the earth side respectively if the resulting performance is acceptable, especially for a large scale ultra-high-

voltage direct-current (UHVDC) converter arrangement. DC filters may be needed if the HVDC transmission line is overhead.

If this configuration is the first stage of a bipolar system, its neutral conductor could be insulated for the high voltage at this stage of development.

For a metallic return scheme, DC fault current will flow into the AC system and come back through neutral point of transformers installed in the converter station. This current may lead to the malfunction of protective relays installed in nearby stations, caused by the saturation of cores due to DC current. To prevent such malfunctions, insertion of neutral grounding resistor (small resistance) to transformers in the converter station will be effective.

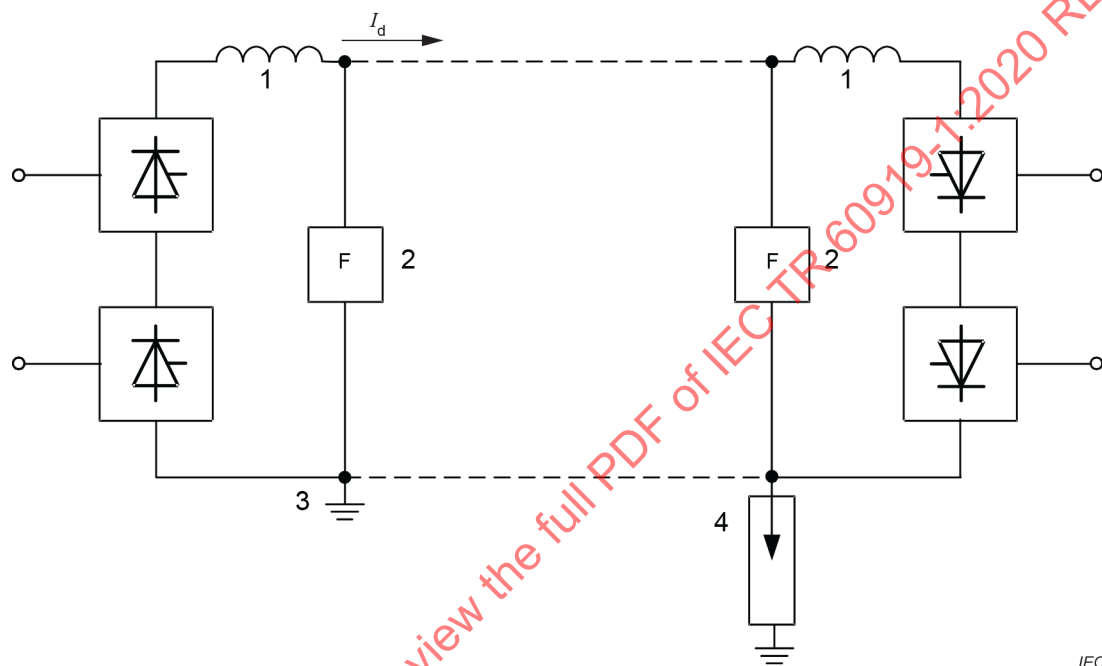

#### Key

- 1 DC reactor
- 2 DC filter
- 3 Station earth
- 4 Arrester

**Figure 6 – Monopolar HVDC system with metallic return**

#### 4.5 Bipolar earth return HVDC system

This is the most commonly used arrangement when a DC transmission line connects two HVDC substations and electrodes for earth return operation are provided (Figure 7 (a)). It is effectively equivalent to a double-circuit AC transmission. It reduces harmonic interference from the DC line as compared with monopolar operation and it keeps earth current flow down to a low value. When combined, two monopolar earth return schemes can give a bipolar scheme.

For power flow in one direction, one pole has positive polarity to earth and the other pole has negative polarity to earth. For power flow in the other direction, the two poles reverse their polarities. When both poles are in operation, the unbalance current flowing in the earth path can be kept at a very low value.

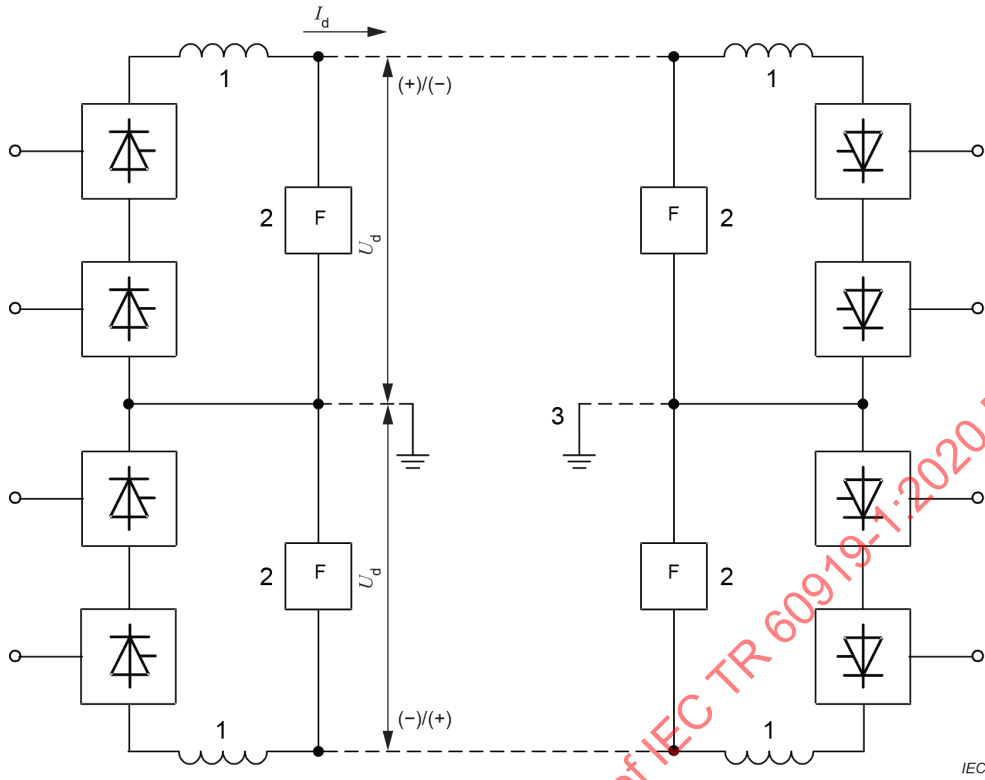

Figure 7 a) – Bipolar HVDC system with earth return

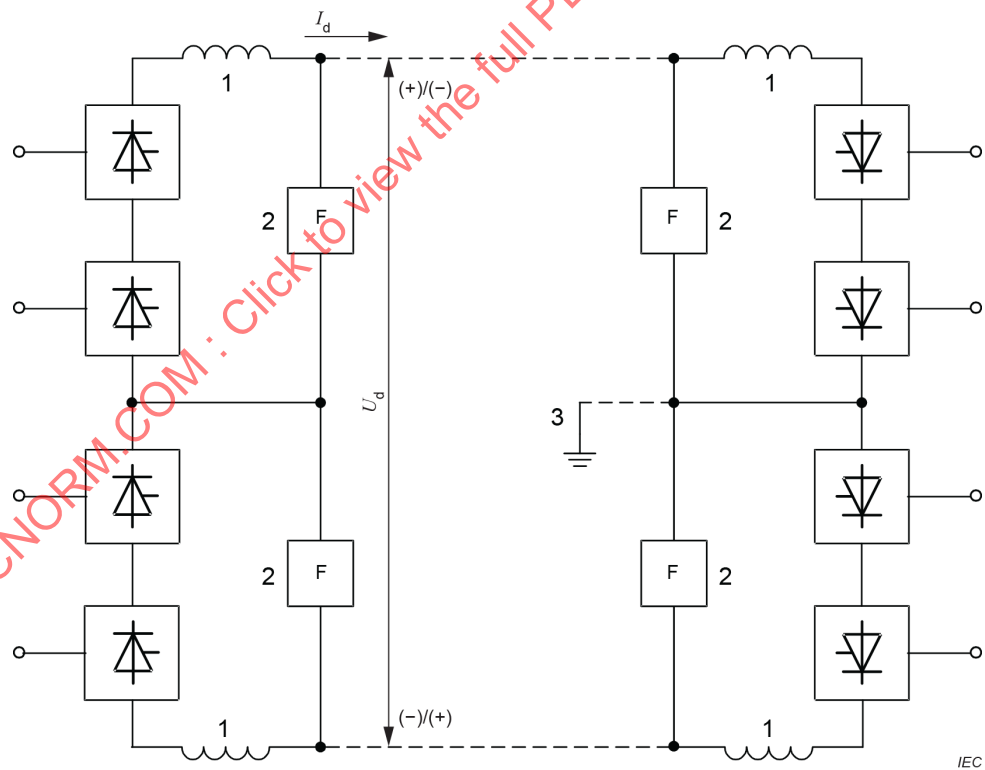

Figure 7 b) – Rigid bipolar HVDC system

**Key**

- 1 DC reactor
- 2 DC filter
- 3 Earth electrodes

**Figure 7 – Bipolar system**

This configuration offers a number of emergency operating modes. Consequently, the requirements in the following list a) to f) should be considered in the specifications.

- a) During an outage of one HVDC transmission line pole 11 in Figure 8 (rectifier DC switches 3 and inverter DC switches 9 have been switched off), the converter equipment of the other pole 12 should be capable of continuous operation with earth return (rectifier DC switches 4, inverter DC switches 10, earth return transfer switch (ERTS) 7 and metallic return transfer breaker (MRTB) 8 have been switched on).
- b) If long-term flow of earth current is undesirable and if the defective line pole still retains some low-voltage insulating capability, the bipolar system should be capable of operation in the monopolar metallic return mode (Figure 8). To switch into this emergency operating mode the conductor of the out-of-service pole 11 is first connected in parallel with the earth path by switching on pole-to-neutral switches 5 and then the earth path is interrupted to transfer the current to the metallic path (through the conductor of the out-of-service pole) by switching off MRTB 8. Load transfer without interruption requires a metallic return transfer breaker (MRTB) at one terminal of the DC transmission. If a short interruption of power flow is permitted, MRTB would not be necessary. The neutral equipment at the MRTB end of the HVDC transmission system should be be insulated from earth for a somewhat higher voltage than at the other end of the system. Figure 8, with DC switches 3 and 4 (named as ERTS and MRTB), is usually valid for a rectifier station. The MRTB is not necessary for the inverter station.

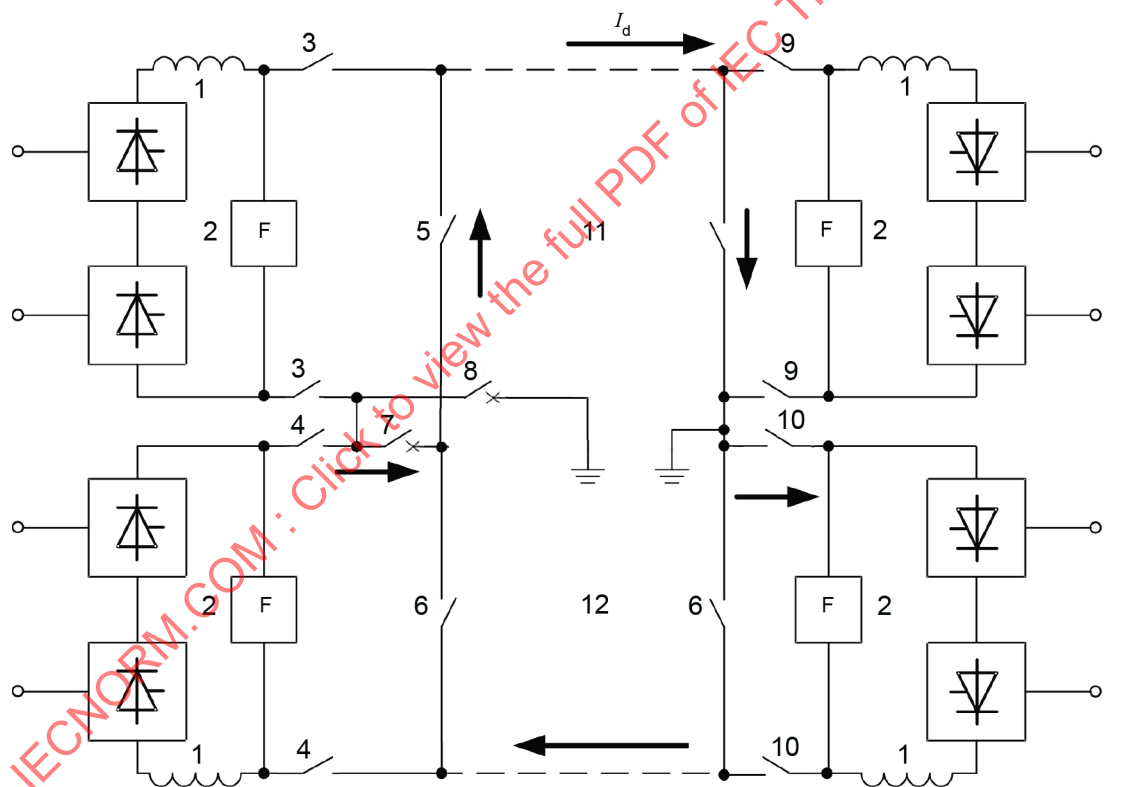

IEC

**Key**

1	DC reactor	7	Earth return transfer switch (ERTS)
2	DC filter	8	Metallic return transfer breaker (MRTB)
3,4	Rectifier DC switches	9,10	Inverter DC switches
5,6	Pole-to-neutral switches	11, 12	HVDC power transmission poles

**Figure 8 – Metallic return operation of the unfaulted pole in a bipolar system**

- c) During maintenance of the earth electrode(s) or the earth electrode line(s), operation of the bipolar system should be possible with the station neutral(s) connected to the station earth at one or both HVDC substations as long as the unbalance current between the two poles entering the station earth(s) is kept at a very low value. The unbalance current

should be kept low to avoid saturation effects in the converter transformers from the flow of part of the unbalance current through the transformer neutrals. In this arrangement when one transmission line of substation pole is lost, both poles should be blocked automatically.

- d) In bipolar operation with both earth electrodes connected, the two poles of the HVDC system should be capable of operation with substantially different currents in each pole. This may be necessary if loss of cooling or some other unusual condition prevents the operation of one pole with full current.
- e) If continuation of operation is required in the case of poor weather conditions or where the line insulation has been partially damaged, the converters should be designed for continuous operation at reduced voltage, so that either pole can be operated at reduced voltage (see 8.3).
- f) In the event of the loss of one transmission line pole, the two substation poles can also be connected in parallel by using appropriate switches for polarity reversal in at least one station pole enabling both poles to operate in the monopolar earth return mode. This, however, requires that the DC terminals of each 12-pulse group be insulated for the full pole voltage and the line and the earth electrode shall be thermally capable of carrying a current higher than the normal current.

One or more DC reactors is needed at each end of the system in each pole, these are usually located on the high-voltage side. However, the DC reactors may be divided into two parts and located on the high-voltage side and the earth side respectively if the resulting performance is acceptable, especially for a large scale ultra-high-voltage direct-current (UHVDC) converter arrangement. If the HVDC system includes an overhead line, DC filters would most likely be needed. One 12-pulse unit per pole is most commonly used; however, large capacity systems or staged expansion may require 12-pulse units in series or in parallel (Figure 4 and Figure 5).

Most HVDC systems utilise ground return or a dedicated metallic return conductor for the DC current path. However, when balanced bipolar operation can always be ensured, these facilities can be eliminated. This scheme is called "rigid bipole HVDC system" configuration, as shown in Figure 7 b). With this scheme, operation modes are limited but installation cost can be reduced.

#### 4.6 Bipolar HVDC system with metallic return

If earth currents are not tolerable (as mentioned in 4.4, item d)) or if the distance between the HVDC system terminals is short, or if an earth electrode is not feasible because of high earth resistivity, then the transmission line may be constructed with a third conductor to give a bipolar HVDC system with metallic return (Figure 9). The third conductor carries unbalance currents during bipolar operation. It also serves as the return path when one transmission line pole is out of service. This third conductor requires only reduced voltage insulation and, in this case, may also serve as a shield wire if the line is overhead. However, if it is fully insulated, it can serve as a spare conductor. In this case, a separate shield wire is required.

The neutral of one of the two HVDC substations should be earthed, while the neutral at the other end of the transmission would float or be tied to its station earth through an arrester, a capacitor or both.

With this design, the system can still be operated in the bipolar mode if one conductor becomes unavailable and the third conductor is fully insulated. Then, the neutrals at both terminals should be connected to their local station earths, and care should be taken to hold the unbalanced current flow to very low values. Loss of one pole will require blocking of the other pole until the necessary switching has taken place for operation of the remaining sound portions of the HVDC transmission system.

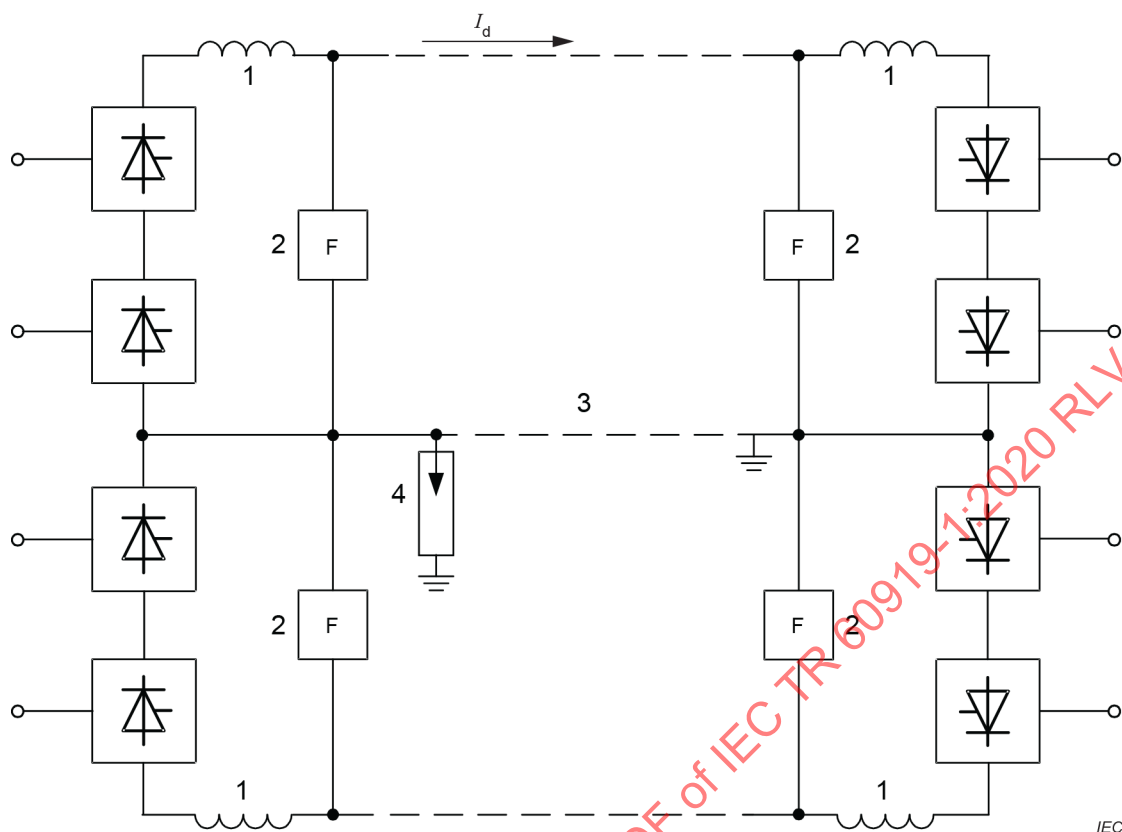
**Key**

- 1 DC reactor
- 2 DC filter
- 3 Metallic neutral
- 4 Arrester

**Figure 9 – Bipolar HVDC system with metallic return**

If one pole becomes unavailable, the system can be operated in monopolar metallic return mode by utilizing the other substation pole. This configuration is also called "metallic return mode" (MRM).

For a metallic return scheme, DC fault current will flow into the AC system and partly come back through neutral point of transformers installed in the converter station. This current may lead to the malfunction of protective relays installed in nearby stations, because of saturation due to DC current. To prevent such malfunctions, insertion of neutral grounding resistor (small resistance) to transformers in converter station will be effective.

#### 4.7 Two 12-pulse groups per pole

For a high-power ultra-high-voltage direct-current (UHVDC) converter arrangement, two 12-pulse units per pole may be a better solution to achieve required rating, because the dimension and weight of converter equipment (especially converter transformer) would become too large if only one 12-pulse unit per pole were used.

Two 12-pulse converters can be connected in series (Figure 10) or in parallel (Figure 11), and the selection of converter arrangement depends on the specific requirements of the project. On the other hand, if a project requires reduced voltage operation, for instance, due to occasional salt contamination, then the series option may be preferred.

The series and parallel options are equivalent in terms of loss of transmitting power when a forced or scheduled outage of a 12-pulse converter occurs. In both cases, only 25 % of the capacity will be lost, assuming all converters have the same power rating. If sufficient overload capability is available, full power or almost full power can be restored. For the series option, the two poles can still operate with balanced current (without earth current) after a forced or scheduled outage of a 12-pulse converter occurs. However, note that a by-pass switch is required for each 12-pulse converter in series connected option. For the parallel option, the two poles can still operate with unbalanced current when a forced or scheduled outage of a 12-pulse converter occurs, while there is large current flowing through earth.

IECNORM.COM : Click to view the full PDF of IEC TR 60919-1:2020 RLV

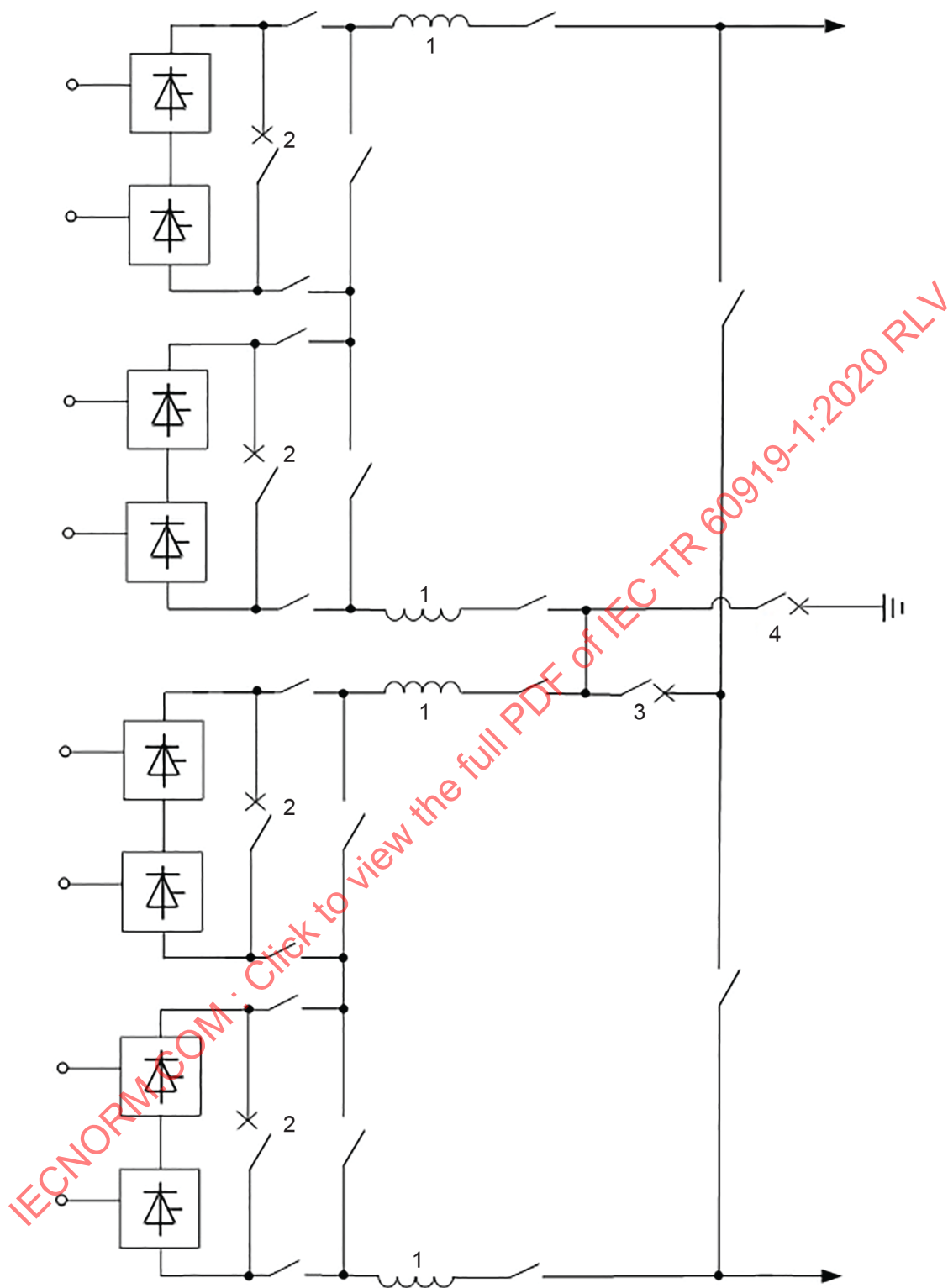

IEC

**Key**

- 1 DC reactor
- 2 By-pass switch
- 3 Earth return transfer switch (ERTS)
- 4 Metallic return transfer breaker (MRTB)

**Figure 10 – Bipolar system with two 12-pulse units in series per pole**

The cost of the two 12-pulse group per-pole arrangement, compared to one 12-pulse group per pole for the same total rating, would be expected to be greater, and the control system will become more complicated.

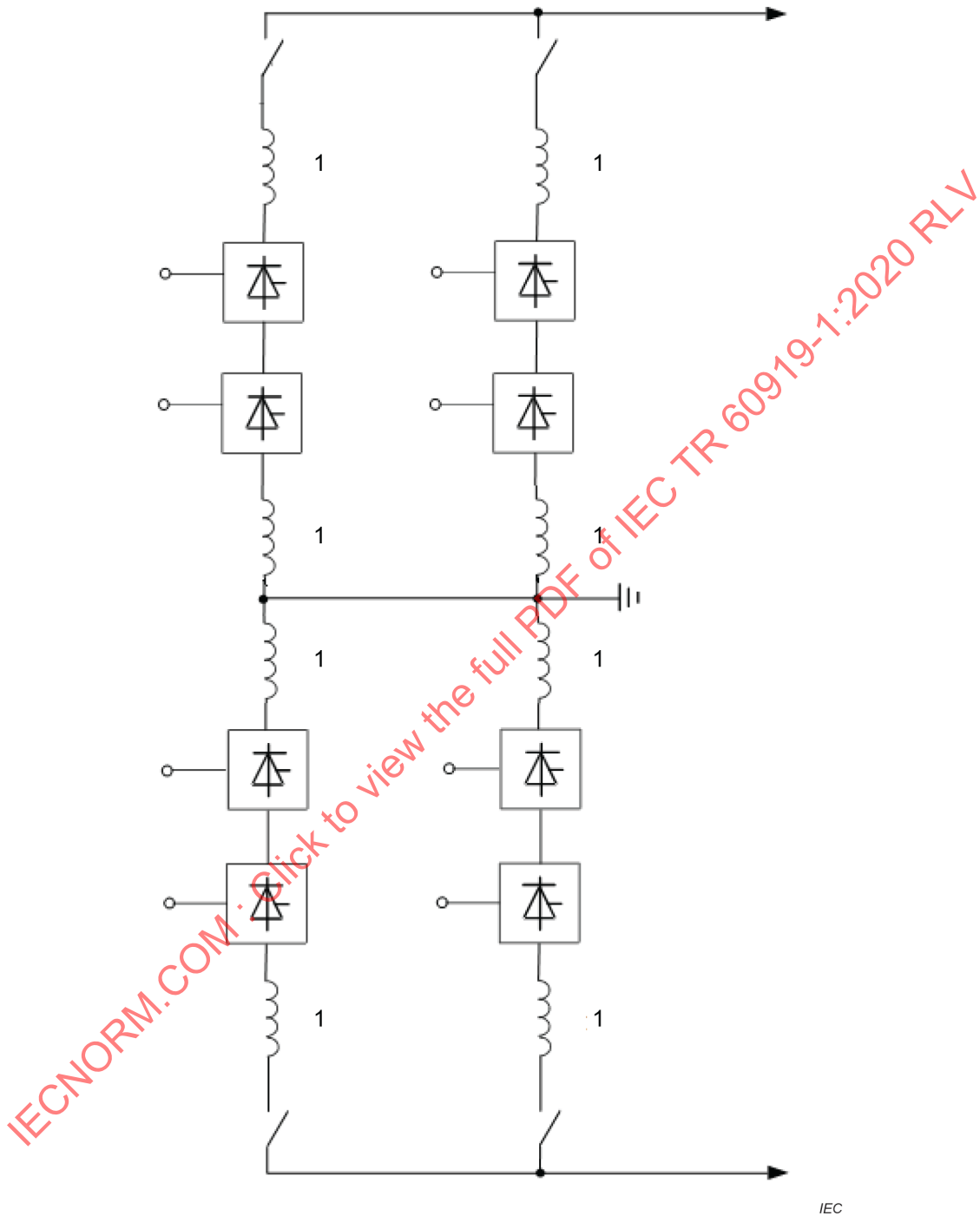

**Key**

1 DC reactor

**Figure 11 – Bipolar system with two 12-pulse units in parallel per pole**

**4.8 Converter transformer arrangements**

Each 12-pulse converter requires two three-phase transformer valve windings, one star-connected and the other delta-connected. These are provided by one of the following:

- a) one three-phase transformer with two valve windings, or
- b) two three-phase transformers, one connected star-star and the other star-delta, or
- c) three single-phase transformers each with two valve windings, one for star connection and the other for delta connection, or
- d) six single-phase transformers, connected in two three-phase banks, one connected star-star and the other star-delta.

Depending on the HVDC system availability requirements, spare transformers may be needed at one or both ends. If one three-phase transformer with two valve windings is used, only one spare unit would be required. Since the star- and delta-connected three-phase transformers would be of different designs, spares considerations would indicate one spare of each design. Only one spare would be required for the single-phase, double-valve winding transformers since all three would be identical. The last of the above options would suggest two spare transformers, one each for the star- and the delta-valve winding single-phase transformers.

If spare transformers are not employed, alternatives b) and d) above allow for six-pulse operation at half-power in case of a transformer outage, if the HVDC system is designed for this mode of operation and the AC and DC harmonic conditions are acceptable. Six-pulse operation is not possible with alternatives a) and c).

It is not always needed to split the DC reactors, especially for parallel connection. The number and arrangement of DC reactors depend on the results of system studies and design.

Converter transformers with a tertiary winding for reactive power and AC harmonic filter equipment may also be used.

#### **4.9 DC switching considerations**

There are a number of possible DC switching arrangements intended to increase HVDC system availability.

Monopolar metallic return operation of a bipolar system is discussed in 4.5.

For bipolar systems, DC switching may be provided (Figure 12) so as to allow the use of any conductor for connection to any substation pole or to neutral. This arrangement is useful for a scheme involving cables and where a fully insulated spare cable is available or cables are connected in parallel. If one substation pole is out of service, then the cables can be paralleled to reduce line losses. Generally, DC buses are fixed in relation to converters, with two pole buses and a neutral bus. This would preclude connection of the two substation poles in parallel.

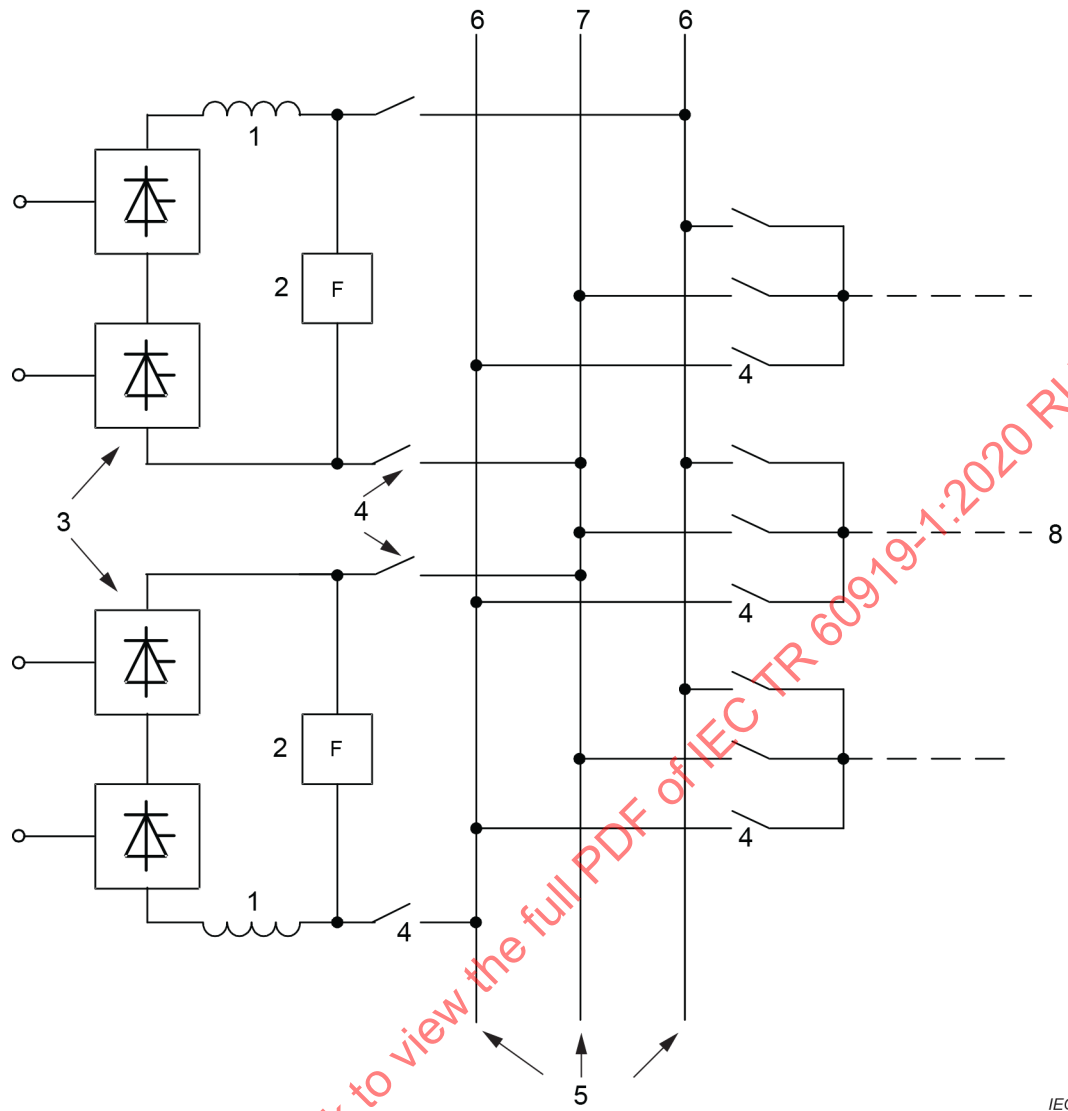

**Key**

- |   |                     |   |               |
|---|---------------------|---|---------------|
| 1 | DC reactor          | 5 | DC bus        |
| 2 | DC filter           | 6 | Pole          |
| 3 | Two-converter poles | 7 | Neutral       |
| 4 | DC switches         | 8 | DC line/cable |

**Figure 12 – DC switching of line conductors**

However, if flexibility of connecting the two substation poles in parallel is needed, then provision for polarity reversal of at least one substation pole could be made and the neutral end of that substation pole will also have to be insulated for full line voltage. A possible switching arrangement is shown in Figure 13.

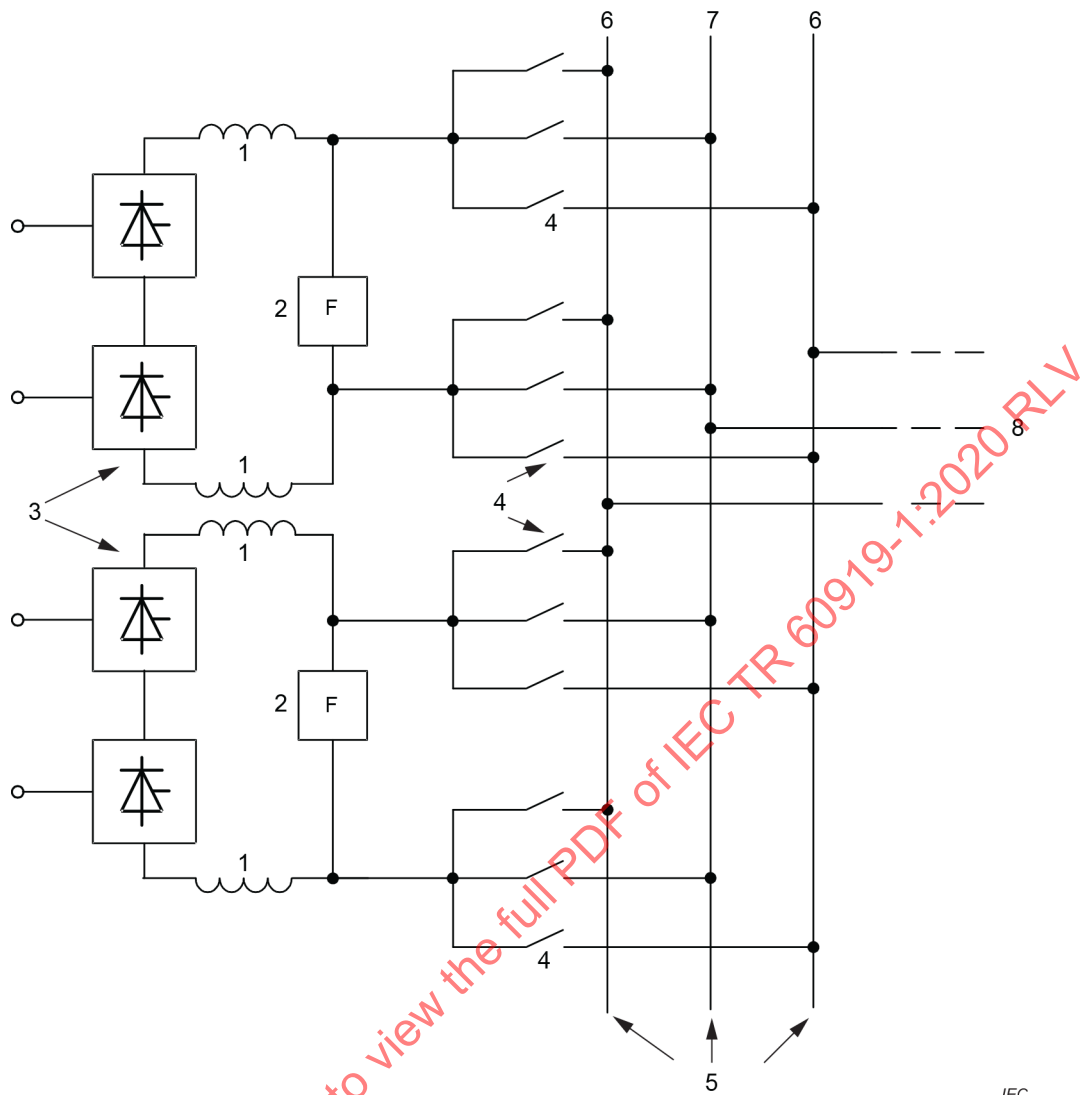

IEC

**Key**

1	DC reactor	5	DC bus
2	DC filter	6	Pole
3	Two-converter poles	7	Neutral
4	DC switches	8	DC line/cable

**Figure 13 – DC switching of converter poles**

If an HVDC transmission system includes both overhead line and cable sections, a DC switching arrangement such as in Figure 14 may be used at the junction of the overhead and cable sections.

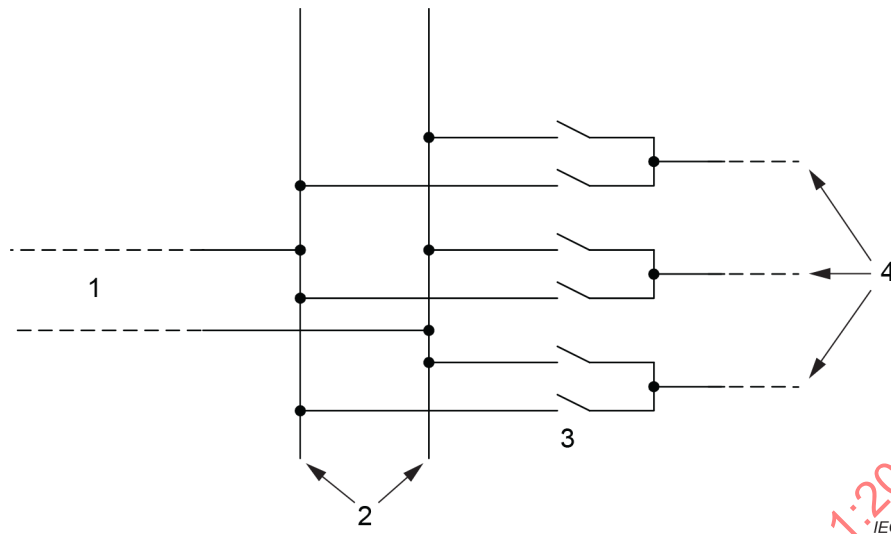

**Key**

- 1 Bipolar overhead line
- 2 DC bus
- 3 DC switches
- 4 DC cables (two poles, one spare)

**Figure 14 – DC switching – Overhead line to cable**

For more than one bipolar line, paralleling of converter poles may be considered, in order to allow restoration of transmission capability (Figure 15) for transmission line outages.

For long bipolar lines in parallel, intermediate switching such as in Figure 16 may be provided.

**4.10 Series-capacitor-compensated HVDC systems**

Although the conventional line-commutated converter (LCC) technology has reached maturity, such converters still have two weaknesses:

- a) a large amount of reactive power consumption, roughly 50 % of its active power;
- b) susceptibility to AC side disturbance, commonly observed as commutation failures.

To overcome these weaknesses, further developments have been made using series-capacitor compensation.

Practically, there are two types of series-capacitor compensated HVDC schemes.

- Capacitor-commutated converter (CCC), in which series capacitors are included between the converter transformer and the valves.
- Controlled series capacitor converter (CSCC) is also suggested. In this scheme, the basic topology of the converter is the same as the conventional topology; however, series capacitors are inserted between the AC filter bus and the AC network. Occurrence of ferroresonance with the CSCC option is eliminated by controlling the amount of series compensation.

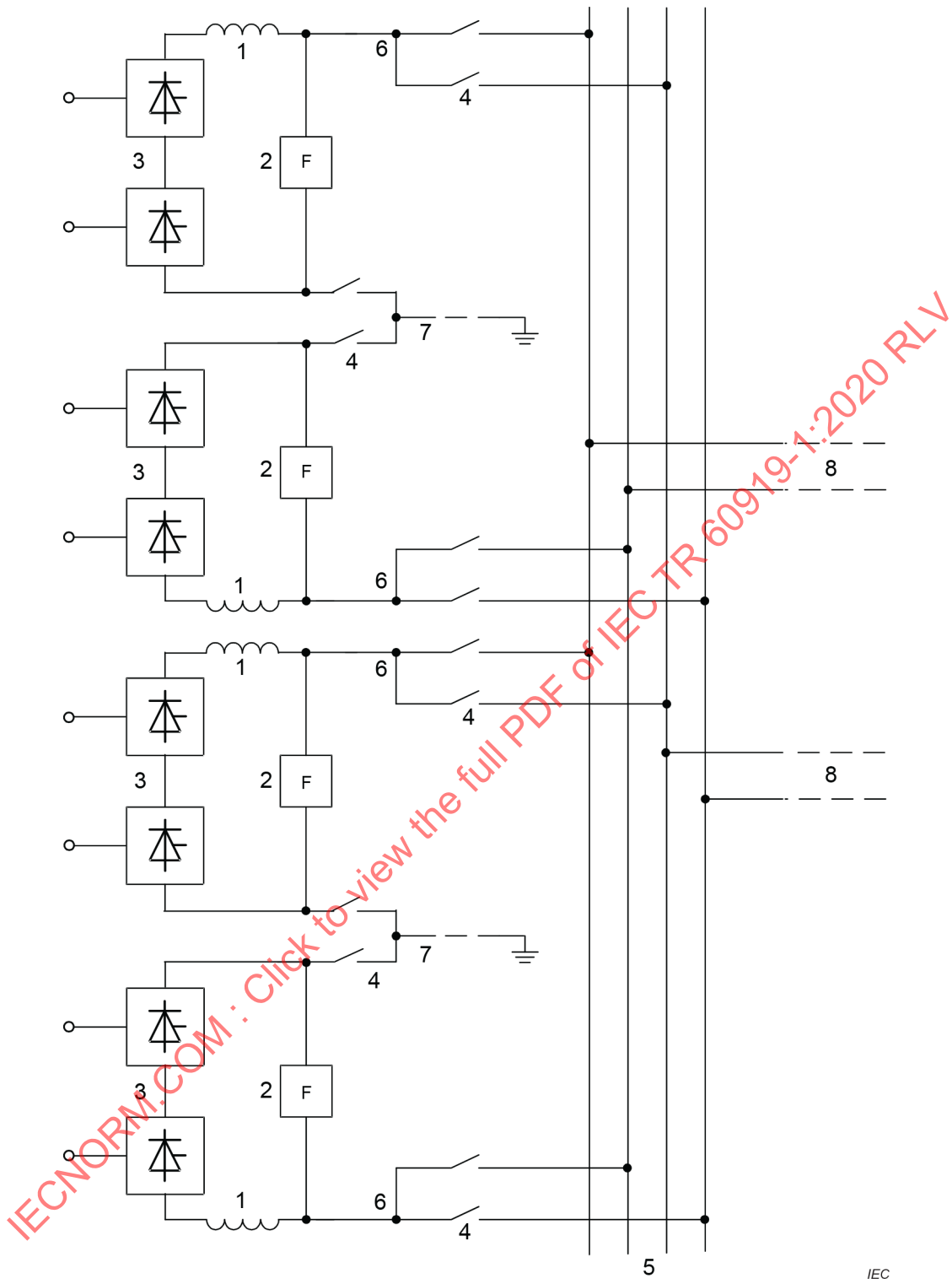

**Key**

- |   |                     |   |               |
|---|---------------------|---|---------------|
| 1 | DC reactor          | 5 | DC bus        |
| 2 | DC filter           | 6 | Pole          |
| 3 | Two-converter poles | 7 | Neutral       |
| 4 | DC switches         | 8 | DC line/cable |

**Figure 15 – DC switching – Two bipolar converters and lines**

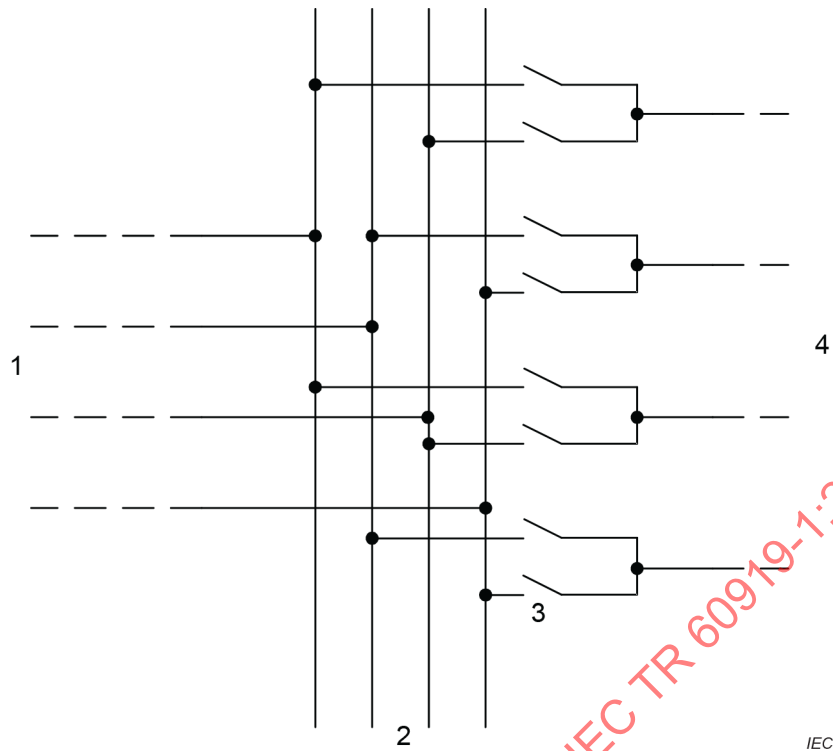

**Key**

- 1 Two bipolar lines
- 2 DC bus
- 3 DC switches
- 4 Two bipolar lines

**Figure 16 – DC switching – Intermediate**

The CCC circuit shown schematically in Figure 17 a) is based on a topology in which series capacitors are included between the converter transformer and the valves. The CSCC circuit has the series capacitors inserted at the connection of the filter bus to the AC system as shown in Figure 17 b). This provides similar performance to the CCC, with the additional advantage of controllability of the reactive power exchange with the AC network.

Both alternatives offer improved immunity from commutation failure, lower load rejection overvoltages and increased stability margins in power control mode, over the conventional HVDC scheme. They are, therefore, suitable candidates for use at the inverter end in long cable systems or in back-to-back ties connected to weak AC systems. The performance of the two alternatives is very similar for steady state as well as transient operation.

The maximum valve voltages and also the AC current harmonics for the CSCC configuration are lower than for the CCC configuration. On the other hand, the CCC in rectifier operation exhibits a smaller valve short-circuit current. The previously identified problem with ferroresonance in the CSCC is eliminated through the application of controlled series capacitors.

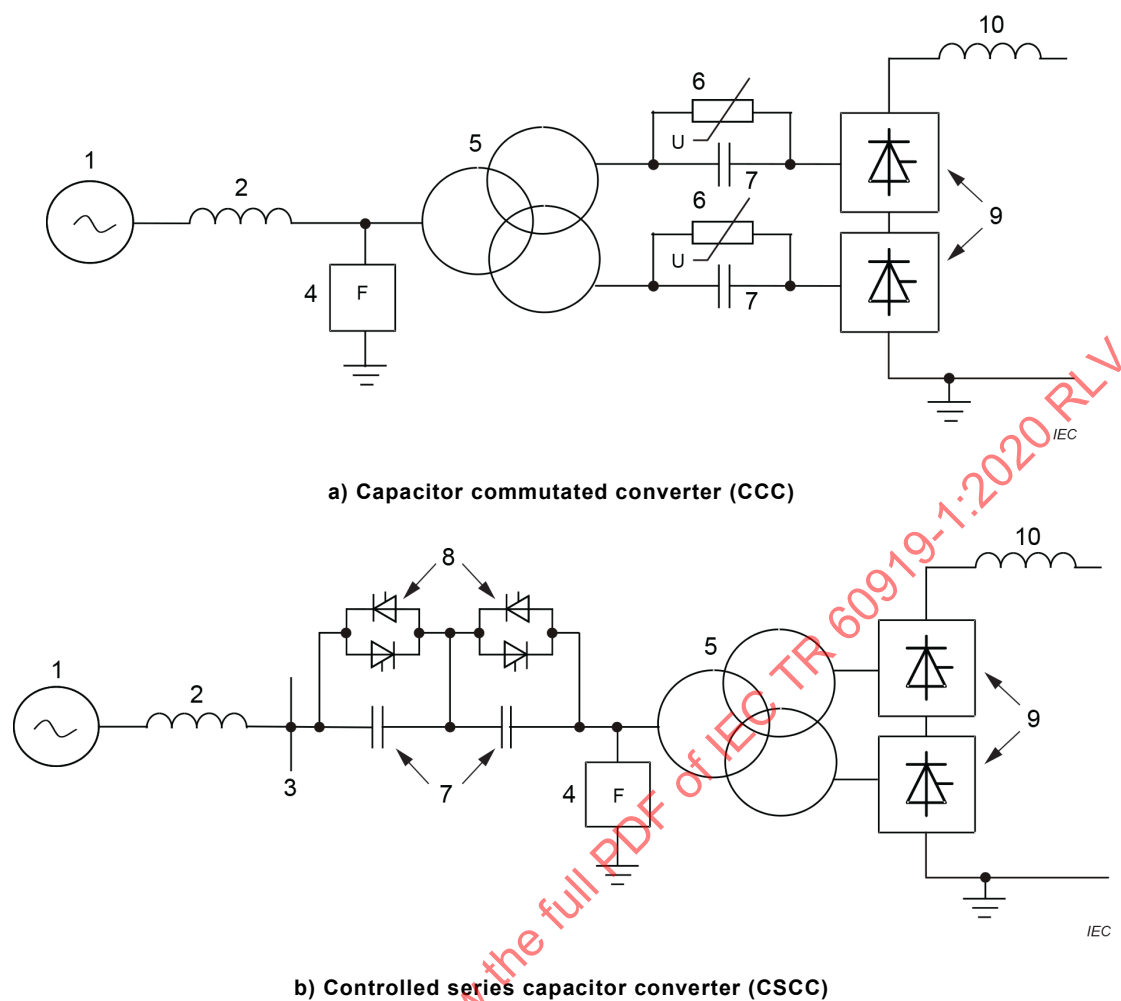
**Key**

1	AC system e.m.f.	6	Overvoltage limiter
2	AC system impedance	7	Capacitor
3	AC system bus	8	Thyristors
4	AC filters	9	Converters
5	Converter transformer	10	DC reactor

**Figure 17 – Capacitor commutated converter configurations**

The advantages of using CCC in comparison with conventional converter may be summarized as follows:

- significantly less reactive power consumption, which, in combination with sharply tuned filter branches, eliminates the need for switching filter and shunt capacitor banks during power ramps;
- immunity to commutation failure during AC side disturbance, which is beneficial with long lines or cables feeding weak AC networks;
- stable operation in lower short-circuit capacity systems;
- lower overall installation cost in some cases, due to elimination of switchable filter and shunt capacitor banks or synchronous compensators, in applications associated with weak AC network connections;
- robustness in situations of converter-arm short-circuit fault due to lower fault current;
- less variation of reactive power during disturbances, which results in improved power quality and reduced load rejection.

The disadvantages are:

- increased harmonic current;
- slightly increased converter losses;
- requirement for detailed study of transient stresses on equipment;
- reduced inherent overload capability, due to the capacitor connected in series with the converter;
- requirement for shielding against lightning and radio interference between the valve winding, the capacitor and the valve;
- slightly increased valve voltage stress.

When CCC or CSCC is being considered as an HVDC topology for a particular project, it should be emphasized that the selection of optimal system rating is different from conventional HVDC. Therefore, in order to make a selection between conventional HVDC schemes and these alternatives, a detailed analysis is required with respect to economics and technical performance, taking into account losses, installation costs, etc.

#### 4.11 LCC/VSC hybrid bipolar system

In case one pole of the LCC is combined with a VSC pole, a hybrid bipolar system of LCC and VSC will be formed. For an LCC/VSC hybrid bipolar system, special consideration should be taken because power reversal of the VSC system requires current reversal, whereas LCC changes voltage polarity. The combined operation of both systems will lead to excessive current on electrode line or return line for one of the power directions. In order to prevent this problem, switches for polarity reversal should be installed on the VSC converter, as depicted in Figure 18.

The other possibility of LCC/VSC hybrid system is the case that consists of LCC for one terminal and VSC for the other terminal. This configuration can be applied to the DC system that transmits power to a weak AC system.

Adopted VSC for hybrid systems should be in asymmetrical monopole configuration.

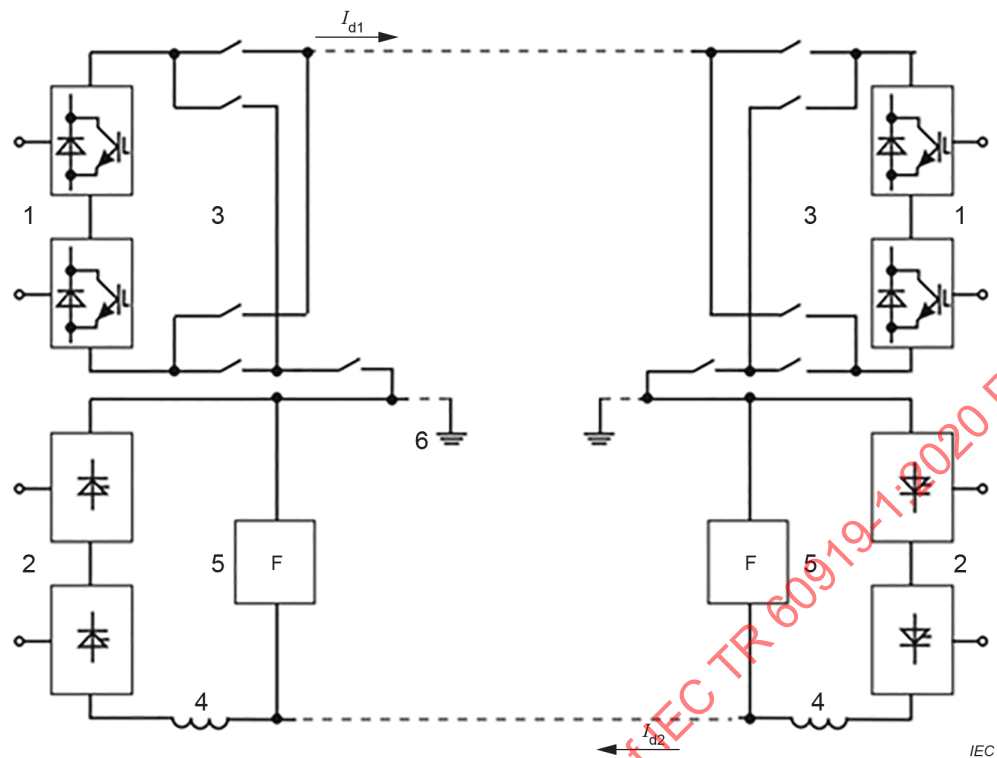
**Key**

- |   |                                 |   |                 |
|---|---------------------------------|---|-----------------|
| 1 | voltage-sourced converter (VSC) | 4 | DC reactor      |
| 2 | line-commutated converter (LCC) | 5 | DC filter       |
| 3 | polarity reversal switches      | 6 | earth electrode |

**Figure 18 – LCC/VSC hybrid bipolar system****5 Environment information**

The location and the information listed in Table 1 should be supplied for each HVDC substation.

**Table 1 – Information supplied for HVDC substation**

Parameter	Unit		Examples of use and comments
Height above sea-level	m		For the design of air-cooling systems and for air clearances
Outdoor air temperature	°C		The maximum temperatures are given for rating purposes and the low temperatures for overload capability requirements. If the user intends to overload the equipment and accept a corresponding loss-of-life expectancy, this should be stated and the necessary information supplied
	For low temperature capability	For rated power capability	If preferred, curves showing how these parameters vary over the year, on a monthly basis, may be provided instead
Maximum dry-bulb temperature	°C	°C	Valve cooling, transformer and reactor design, AC and DC filter design
Maximum wet-bulb temperature	°C	°C	Evaporative cooling system design and of valve hall relative humidity
Maximum average dry-bulb temperature for a period of 24 h	°C	°C	Oil insulated transformer and reactor design
Minimum average dry-bulb temperature for a period of 24 h	°C	-	Transformer, reactor and disconnector switch design and building heating needs
Minimum dry-bulb temperature	°C	-	Transformer, reactor and disconnector switch design and building heating needs, AC and DC filter design
Maximum and minimum indoor air temperatures and relative humidity	°C	°C	Usually determined by the valve designer for the valve hall and by the control designer for the control room
	%	%	
Indoor air temperatures and relative humidity during maintenance and maximum transition time after shutdown	°C	°C	Specified if indoor temperature extremes are too great for maintenance personnel
	%	%	
Maximum incident solar radiation			Building cooling, ratings of transformers, reactors, buses, etc.
Horizontal surface	W/m <sup>2</sup>		
Vertical surface	W/m <sup>2</sup>		
Wind conditions			Equipment support and building design
Maximum continuous velocity	m/s		
Maximum gust velocity	m/s		
Maximum velocity at a minimum temperature ..... °C	m/s		Conductor, strain insulator and tower design
Ice and snow covering load			Equipment and structure design, for example, disconnector/switch, conductor, etc.
Maximum ice thickness with no wind	mm		
Maximum ice thickness with a maximum wind speed of .....m/s	mm		
Maximum snow load	N/m <sup>2</sup>		
Maximum depth of snow	mm		Equipment height above snow for safety purposes

Parameter	Unit	Examples of use and comments	
Rainfall		Building and site drainage	
Annual average	mm		
Maximum in a period of 1 h	mm		
Maximum in a period of 5 min	mm		
Fog and contamination Utility practice for insulator washing and greasing		To determine requirements for insulation and air-cooling system filter design. An estimated equivalent salt deposit density level should be specified for insulator design	
Keraunic level at the station and the first 5 km to 10 km of the line	Strokes/km <sup>2</sup> /year (substation) Strokes/100 km/year	Station lightning protection design	
Seismic conditions		Equipment, structure and foundation design	
Maximum horizontal acceleration	m/s <sup>2</sup>		
frequency range of horizontal oscillations	Hz		
Maximum vertical acceleration	m/s <sup>2</sup>		
frequency range of vertical oscillations	Hz		
Duration of seismic event	Cycles		
Cooling water available at the site (if used for secondary cooling)		Secondary cooling water may be used either for make-up and blow-down of evaporative coolers or for once-through cooling. Evaporative cooling towers can be a source of high humidity for the insulators and should be carefully located	
Source of water		Reservoir, well, etc. If preferred, curves showing how these parameters vary over the year on a monthly basis may be provided instead.	
	For low temperature capability	For rated power capability	
Maximum continuous flow rate	m <sup>3</sup> /s	m <sup>3</sup> /s	Required for cooling system design
Maximum flow rate for a period of 24 h	m <sup>3</sup> /s	m <sup>3</sup> /s	Required for cooling system design
Minimum continuous flow rate	m <sup>3</sup> /s	m <sup>3</sup> /s	Required for cooling system design
Minimum flow rate for a period of 24 h	m <sup>3</sup> /s	m <sup>3</sup> /s	Required for cooling system design
Maximum water temperature	-	°C	Required for cooling system design
Minimum water temperature	°C	-	Required for cooling system design
Maximum allowable water temperature to drain	°C	°C	Required for cooling system design
pH level			Design of water treatment plant
Conductivity of water	μ Siemens/m		Parameters apply only in the case where well water is used for evaporative cooling Design of water treatment plant
Type of dissolved solids			Design of water treatment plant
Quantity of dissolved solids	g/m <sup>3</sup>		Design of water treatment plant
Type of undissolved solids			Design of water treatment plant
Quantity of undissolved solids	g/m <sup>3</sup>		Design of water treatment plant
Maximum earth resistivity at the HVDC substation	Ωm		Station earth design
– Depth of water table	m		Foundation design
– Site soil conditions			Bore hole information (for example, rocks) and any special conditions, such as maximum frost depths, foundation design

Parameter	Unit	Examples of use and comments
– Site accessibility	kg, m	To determine installation and delivery costs
– Weight and size limitations for transportation		Equipment design – especially transformers and DC reactors
– Local profile limitations on equipment and buildings		Influence on equipment, bus and building design
– Environmental considerations		Audible noise limits, aesthetic requirements – architectural treatment, landscaping, etc.
Any special conditions not listed above, for instance, related regulations, which influence system performance should be given.		

## 6 Rated power, current and voltage

### 6.1 Rated power

#### 6.1.1 General

Rated power is the active power which the HVDC system shall be able to transmit continuously, over the range of ambient conditions specified, with all equipment in service, but without the need to utilize redundant components; the HVDC system voltage and frequency as well as the converter firing angle and the extinction angle being in their steady-state range.

Because an HVDC transmission system in general consists of three sections, i.e. the two HVDC substations and the transmission line, each of which produces losses, the point of measurement of rated power should be specified.

#### 6.1.2 Rated power of an HVDC system with transmission line

The rated power of an HVDC transmission system on a per-pole basis is defined as the product of rated direct voltage times rated direct current.

For a given direct current, transmission line losses vary with ambient conditions, which can be non-uniform along the length of the line. Therefore, it is customary to specify rated power at the rectifier DC bus. If the required transmission capability is defined at some other location, i.e. the sending-end AC bus, receiving-end AC bus, or somewhere along the HVDC transmission line, then the rated DC voltage should be defined and the rated direct current should be chosen through design optimization of the HVDC system.

Rated power and voltage at the inverter DC bus are derived values from rectifier quantities, and line losses are usually based on defined conductor parameters and uniform conductor temperature assumptions along the line.

Long distance HVDC systems may be monopolar or bipolar. Rated power should be specified on a per-pole basis stating the number of poles.

#### 6.1.3 Rated power of an HVDC back-to-back system

With system ties in a back-to-back configuration, there is no transmission line. Therefore, the rated DC voltage and current are chosen through design optimization of the HVDC system. Moreover, the rectifier and inverter are solidly connected at the DC side, operating as one unit. Rated power of such a system can, therefore, be defined as the product of rated direct voltage times the rated direct current.

#### 6.1.4 Direction of power flow

If the same power rating is required in each direction, such as with system ties for power exchange, this should be stated.

Where power flow is primarily in one direction, such as with systems fed from remote generation, rated power may be specified only for that direction to minimize the inverter cost. Then a lower inherent transmission capability should be accepted for reversal of power flow.

#### 6.2 Rated current

Rated direct current is the mean value of the direct current that the system should be able to transmit continuously for all ambient conditions specified and without time limitations. The rated current should not be specified for back-to-back systems as detailed in 4.2, unless there are specific reasons for doing so.

#### 6.3 Rated voltage

The rated voltage is the mean value of the required direct voltage to transmit rated power at rated direct current. It is measured between the high-voltage bus at the line side of the DC reactor and the low-voltage bus at the HVDC substation, excluding the earth electrode line. The rated voltage is defined at nominal AC system voltage and nominal converter firing angle while operating at rated direct current.

For long distance HVDC transmission systems, the rated voltage should be specified at the sending end. If the voltage capability of the transmission line is higher than the rated voltage, then this shall be stated. The rated voltage need not be specified for back-to-back systems as detailed in 6.1.3, unless there are specific reasons for doing so.

### 7 Overload and equipment capability

#### 7.1 Overload

Overload in an HVDC substation usually refers to direct current flow above its rated value. For this, consideration may be given to acceptable reduction in life expectancy of equipment (for example, due to thermal ageing), use of redundancy, and low ambient temperatures.

Overload may be specified in terms of power. Voltage regulation in the converter including the transformer normally causes a reduction of DC voltage under overload conditions and hence an increase in current somewhat more than an amount proportional to the increase in power. If rated voltage is to be maintained under overload conditions, then the following measures may be adopted, at additional cost.

- a) The converter should be designed for a higher no-load voltage. This results in a higher MVA rating if overload is required over the full range of AC bus voltage.

NOTE This cannot be necessary if overload is required only for the upper range of the steady-state AC system voltage.

- b) The voltage rating of the converter valves, which is based on transformer no-load voltage, should be increased.
- c) The on-load tap changer range should be increased if the converter firing angle is to be maintained at its nominal value. Alternatively, the converter may be designed for a higher nominal firing angle at rated power. This will increase reactive power consumption, harmonics and losses, as well as the internal stresses on valve components.

As a consequence, if rated direct voltage is to be maintained under overload conditions, oversizing of equipment will be necessary.

For a more economical design, an overcurrent rating may be specified, without regard for direct voltage regulation. Basic converter equations then permit determination of the maximum current, beyond which further increase would be offset by excessive voltage regulations.

When the converter is operated in overload it will absorb more reactive power. Unless this increased reactive power absorption can be compensated by filters/shunt capacitors, for example, from another pole, then the AC busbar voltage will reduce. When the AC system short-circuit level is low, this effect may limit the achievable overload.

The required duration of HVDC substation overloading is most often determined by AC system needs, especially following contingencies in either the AC or HVDC system.

However, some constraints should be observed for the HVDC substation equipment. Thermal time constants range from 1 s to some hours, as detailed in 7.2. Longer duration overload requirements of high magnitude may, therefore, result in an effectively increased rating of equipment and thus impose a greater cost or a reduction of life expectancy. These factors should be weighed against system benefits when specifying overload.

**EXAMPLE** A practical value can be a 1,2 per unit overload for 1 h which does not result in loss of life expectancy of oil-cooled transformers and reactors but it is possible that it will have to be designed into thyristor valves. Also depending on the particular design, it is possible that the 1 h overload will be converted to continuous if cooling redundancy is utilized. Other examples include oscillatory overloads at a frequency of up to 1 Hz for durations of several seconds, for example for power oscillation damping, and 5 s overloads to counteract temporary overvoltage or frequency changes.

The frequency and the time intervals between such overload cycles should be specified.

## **7.2 Equipment capability**

### **7.2.1 General**

This is defined as the ability of the HVDC substation equipment to permit transmission of greater than rated power, without loss of equipment life expectancy. It depends on operating conditions as well as on the design criteria for individual components. Implications resulting from the latter are discussed in subsequent subclauses with respect to their bearing on overload specifications.

Ambient temperature is an important factor. Power equipment is designed to perform at rated loading under the most adverse ambient conditions specified. However, these conditions normally prevail for only limited time periods. At low ambient temperatures, some margin is available for increased capability if the constraints listed in 7.2.4 can be overcome. This margin depends on the design chosen for the particular equipment and would differ for various HVDC substation components. An enveloping curve of transmission capability versus ambient temperature can be specified along with the AC system conditions to be met. This should be specified in terms of wet-bulb and dry-bulb ambient temperatures.

### **7.2.2 Converter valve capability**

The thermal time constant of the thyristor heat sink combination in a thyristor valve is rather small (several seconds up to a few minutes). Overloads following continuous operation at rated current and at maximum ambient temperatures increase the thyristor junction temperature. This should be considered with respect to the specified fault suppression capability of the valve. Consequently, thyristor valve cooling should be designed so that safe operating temperatures are not exceeded even during specified overload operation.

Redundancy is provided as a general practice in the valve cooling circuit. Valves are designed such that the specified rating will be met under the most adverse ambient conditions and loss of thyristor cooling equipment redundancy. If additional capability is needed when redundant cooling is not available, this should be explicitly specified.

On the other hand, with all redundant cooling equipment in service, extra thermal capability is available. The resulting greater-than-normal current capabilities depend on the thermal design of the valve and on the cooling system.

In view of the above, converter overload specifications should state the magnitude and duration of overload, frequency of oscillatory overloads for modulation purposes, as well as the cooling equipment status to be assumed at maximum ambient temperatures.

### **7.2.3 Capability of oil-cooled transformers and reactors**

The thermal time constant of the transformer or reactor windings is approximately 15 min and ranges from one to several hours for their oil circuits (if any), depending on the design.

Consequently, for short time overloads in the 5 s range, oil-cooled equipment is not the limiting factor on HVDC substation overloads. For overloads lasting longer than 1 h, it should be specified whether loss-of-life expectancy is permitted. The expected frequency of occurrence of such overloads should be specified.

### **7.2.4 AC harmonic filter and reactive power compensation equipment capability**

HVDC substation overloads will usually generate increased harmonic currents. These in turn increase harmonic loading, losses in filters and harmonic interference levels. The specifications should state whether the interference performance under rated conditions should be met under overload conditions or to what extent degradation of performance is permitted.

Also, since overload increases the converter reactive power consumption, the specifications should state how this is to be taken into account when designing reactive power compensation equipment. If additional reactive power is drawn from the system under HVDC substation overload conditions, excessive AC bus voltage regulation and a consequent reduction in power flow may take place. For this reason, the expected AC bus voltage under overload conditions should be specified. Air-cored equipment such as air-cored reactors should be specified especially for their overload capability.

### **7.2.5 Switchgear and buswork capability**

Switchgear and buswork normally do not impose limits on HVDC substation overloads unless paralleling of converters is planned. However, special attention should be paid to the overload capabilities of current transformers and bushings.

## **8 Minimum power transfer and no-load stand-by state**

### **8.1 General**

With HVDC substations there exists a minimum steady-state direct current limit. This is due to the fact that at some low level the current becomes discontinuous and is the principal criterion for a minimum power limit.

### **8.2 Minimum current**

Since the direct voltage output of an HVDC converter is made of sections of the sinusoidal bus voltage, direct current would not be a smooth or constant quantity by itself. Rather, it is made continuous by the DC reactor connected in series with the converter. Assuming a constant average direct voltage, the direct current would become discontinuous, at low power, depending on the commutating reactance of the converters, the inductance of the DC reactor, the number of valve groups in service, where series connection of groups is used, and converter firing angle, as well as the negative sequence component of the AC system voltages. Discontinuous current should be avoided in steady-state operation, unless the converter equipment is designed for this mode of operation.

Since the DC reactor inductance is usually determined by other criteria and the firing angle can be of any value, a minimum current limited shall be specified. A value of 5 % to 10 % of rated current is commonly used. This minimum direct current can further be reduced by choosing a larger value of DC reactor inductance.

### **8.3 Reduced direct voltage operation**

Under contamination conditions, often in combination with unfavourable weather conditions, operation of an overhead DC transmission line may not be possible at its rated voltage. However, the control system of the HVDC substation offers various means to achieve continuation of power flow at reduced transmission voltages.

One possibility is to move the transformer tap changer to the position resulting in the lowest AC voltage for the valves. In addition, a further decrease of transmission voltage can be achieved through operation at an increased firing angle.

This requirement could mean a special valve design and thus increase valve costs. Furthermore, since operation at large firing angles causes an increased harmonic generation and reactive power consumption, operation at reduced direct voltage then requires a reduction of the direct current if the filtering and compensation equipment is not rated for these conditions.

Other possibilities are to increase the tap changer range, or where the HVDC system is fed from an isolated power station, a reduction of AC bus voltage can also be considered.

Practical values for reduced direct voltage operation are at 70 % to 80 % of rated voltage, perhaps at reduced current. It is reasonable to expect continuous operating capability at approximately rated current at 75 % voltage with use of redundant cooling, provided that somewhat higher harmonic interference level is acceptable; this in turn depends on expected frequency and duration of such operations.

Where two series-connected 12-pulse converter units are used in each pole, one unit can be switched out, resulting for example in a 50 % voltage reduction when both have the same rating, thus eliminating the necessity to operate at increased converter firing angle or reduced direct current.

To arrive at an economic design of the equipment, the AC voltage levels should be specified for expected direct voltage operations.

### **8.4 No-load stand-by state**

#### **8.4.1 General**

In this mode, the HVDC substation is ready for immediate pick-up of load without the need for a lengthy start-up procedure. A definition of the status of various pieces of equipment shall be specified to determine the no-load losses of the HVDC substation, if operation in the no-load stand-by state is planned.

#### **8.4.2 Converter transformers – No-load stand-by**

The converter transformers may remain energized or de-energized, depending on the user's policies with respect to losses. In the latter case, account should be taken of the time required for inrush currents to decay. Oil pumps and coolers should be in operation on a minimum level, as appropriate to the design of the transformers.

#### **8.4.3 Converter valves – No-load stand-by**

The converter valves should be in the blocked condition. There will be small losses in the voltage grading circuits if the converter transformers are energized. Primary, secondary and

valve hall cooling should be in operation at a sufficient level to permit immediate pick-up of load.

#### **8.4.4 AC filters and reactive compensation – No-load stand-by**

The AC filters and reactive compensation may be connected or disconnected depending on reactive power control strategy within the AC system. However, for the sake of no-load loss determinations, they should be considered disconnected.

#### **8.4.5 DC reactors and DC filters – No-load stand-by**

The DC reactors and DC filters should be connected. Pumps and coolers for DC reactors (where fitted) should be in operation on a minimum level, as appropriate to the design of the reactors.

#### **8.4.6 Auxiliary power system – No-load stand-by**

The auxiliary power system should be fully operative and ready to pick-up rated load, for example, all station service transformers energized, battery chargers in operation.

#### **8.4.7 Control and protection – No-load stand-by**

All control and protection circuits should be operative.

### **9 AC system**

#### **9.1 General**

The following information in Clause 9 should be specified for AC systems at both ends for each stage of development as well as for expected future changes. Different values may be specified for performance and rating purposes.

The arrangement of the AC switchgear to which the converter units and filters are to be connected, including AC lines, should be described. This should also be done for the planned operating schemes of the switchyard.

Specific data should be made available for generators in the close vicinity, particularly if the major load for the generators is served through the rectifier. Often all data pertinent to load flow and short-circuit studies are also needed.

#### **9.2 AC voltage**

##### **9.2.1 Rated AC voltage**

Rated AC voltage is the RMS phase-to-phase fundamental frequency voltage for which the system is designed and to which certain characteristics of the AC equipment are related, such as AC switchgear, AC filters, reactive power compensation equipment, primary windings of converter transformers, etc.

Rated voltage may be used to define the rated power of such AC equipment.

##### **9.2.2 Steady-state voltage range**

###### **9.2.2.1 General**

The steady-state voltage range is the range over which the HVDC system should be able to transmit rated power and over which all performance requirements are to be met, unless stated otherwise.

Any special performance requirements beyond the limits of the steady-state range should be specified. These may affect the design of main equipment, converter transformers, filters, auxiliary equipment, etc.

### 9.2.2.2 Short-term voltage range

There may be situations under which the voltage exceeds the normal steady-state operating range but the HVDC system may be required to remain in operation. Under these conditions the HVDC system may be designed to operate in a manner whereby no equipment should be at risk of damage, but the performance limits of the system may be acceptably degraded (for harmonics, losses, etc.).

The acceptable degraded performance limits should be specified since these will have an effect upon the ratings of equipment.

The HVDC control system may even be specified to assist in the restoration of the voltage to within the normal operating range (through either HVDC control action or addition/removal of filters and reactors) if this is appropriate.

### 9.2.2.3 Voltage variation during emergency

Dynamic overvoltages could determine ratings and protection strategies.

Under extreme circumstances, the AC voltage may exceed even the short-term range, in which case it may be desirable to remove the HVDC system from operation in order to protect the equipment. Alternatively, it may be possible to rate the HVDC converter equipment to operate within these limits, although this will probably require higher cost equipment and degraded performance.

The HVDC control system may even be specified to assist in the restoration of the voltage to within the normal operating range (through either HVDC control action or addition/removal of filters and reactors), if this is appropriate.

### 9.2.3 Negative sequence voltage

The negative sequence component of AC voltage calculated according to the method of symmetrical components is that balanced set of three-phase voltages whose maxima occur in the opposite order to that of the positive sequence voltages. It is generally expressed as a percentage of the rated voltage.

Although it is difficult to obtain an actual value for this parameter, the maximum to be used in determination of non-characteristic harmonics of the current on the AC side and the non-characteristic harmonic voltages on the DC side should be specified. These harmonic currents and voltages are respectively used for the design of the AC filter, DC filter and DC reactor (see Clauses 17, 18, and 21).

## 9.3 Frequency

### 9.3.1 Rated frequency

The frequency of an AC system should be specified to give the basis of rating of the AC equipment, converter transformer, etc., as well as converter bridges and control.

The design of the DC filters is also influenced by the AC system frequency.

### 9.3.2 Steady-state frequency range

Steady-state frequency range is the range, in conjunction with the AC voltage steady-state range, over which the rated power may be transmitted and all performance requirements are to be met.

### 9.3.3 Short-term frequency variation

Limits and duration of short-term frequency excursions for which system performance is required should be specified. This can be a sensitive parameter for AC and DC filter design. Filtering performance during such variations may be specified.

### 9.3.4 Frequency variation during emergency

During an emergency the AC system frequency may reach extreme values for limited periods. These values and their expected durations should be specified. In this condition, the equipment should remain in service without damage, but should not be required to meet the performance specified. For excursions beyond the specified operating frequency limits, it may be permissible to automatically disconnect the equipment.

## 9.4 System impedance at fundamental frequency

For the purpose of analysis of commutation conditions in the converter, the system impedance at fundamental frequency should be stated. Maximum and minimum values of the subtransient impedance at the AC bus, without any filter or compensating equipment, are needed for such analysis.

Subtransient impedance is the positive sequence impedance of the AC system as determined by the subtransient reactance of synchronous machines, leakage reactance of induction machines and positive sequence impedance of connecting lines.

Additionally, a detailed AC system impedance or a suitable equivalent should be specified, in order to optimize the DC control.

## 9.5 System impedance at harmonic frequencies

System impedance at all harmonic frequencies from the 2nd up to the 50th is needed for AC filter design and performance calculations.

This impedance may be calculated using the parameters of the lines, transformers and generators up to five to eight HVDC substation buses. However, this impedance may change considerably under different load conditions and extension stages of the system. Therefore, it is usually more convenient to use an  $R$ - $X$  diagram and to plot the envelope of the locus of the system harmonic impedance under expected system conditions. The values of  $R_{\min}$  and  $X_{\min}$  should be included in the diagram.

In practice, this diagram may take various forms such as a circular plot, limited by constant  $R/X$  ratio or a series of polygons defining ranges of harmonic impedance for each frequency. Further guidance can be found in IEC TR 62001 (all parts).

## 9.6 Positive and zero-sequence surge impedance

The positive and zero-sequence surge impedance is needed for all AC lines going into the station for evaluation of interference from converters in the carrier frequency band and for design of appropriate filters.

## 9.7 Other sources of harmonics

Other sources of harmonics electrically close to the HVDC substation should be identified. Their influence should be taken into account in AC filter and capacitor bank ratings. Generated harmonic currents should be stated for the static reactive power compensators connected to the converter substation bus or to nearby AC substations.

## 9.8 Subsynchronous torsional interaction (SSTI)

If subsynchronous torsional interaction (SSTI) problems are expected, all related information from the pertinent studies should be provided (see also 13.2.4).

# 10 Reactive power

## 10.1 General

Clause 10 identifies the considerations relevant to reactive power.

## 10.2 Conventional HVDC systems

Line commutation of converter bridges, as used in conventional HVDC systems, requires a consumption of reactive power in both rectifier and inverter operation. At full load, this consumption represents 50 % to 60 % of rated power for commonly used values of transformer impedance and firing angle or extinction angle.

At partial load reactive power consumption can be varied according to AC system requirements by using an appropriate control strategy. A control strategy which is often adopted is to maintain the delay angle  $\alpha$  in the rectifier, or the extinction angle  $\gamma$  in the inverter, within narrow limits by means of the tap changer of the converter transformer. Under this strategy, the variation of reactive power versus real power is shown in Figure 19, curve 1, for constant direct voltage and constant extinction angle  $\gamma$ . As an alternative, a linear variation may be obtained, as shown on Figure 19, curve 2, which involves maintaining constant no-load direct voltage  $U_{d0}$  by means of an increase of the delay angle  $\alpha$  in the rectifier and extinction angle  $\gamma$  in the inverter, when the load is reduced.

If the direct current is kept constant and partial load is achieved by increasing the delay angle and thus reducing the direct voltage, reactive power consumption is increased at partial load according to curve 3 in Figure 19. Any characteristic between curves 1 and 3 can be implemented to meet specific AC system requirements.

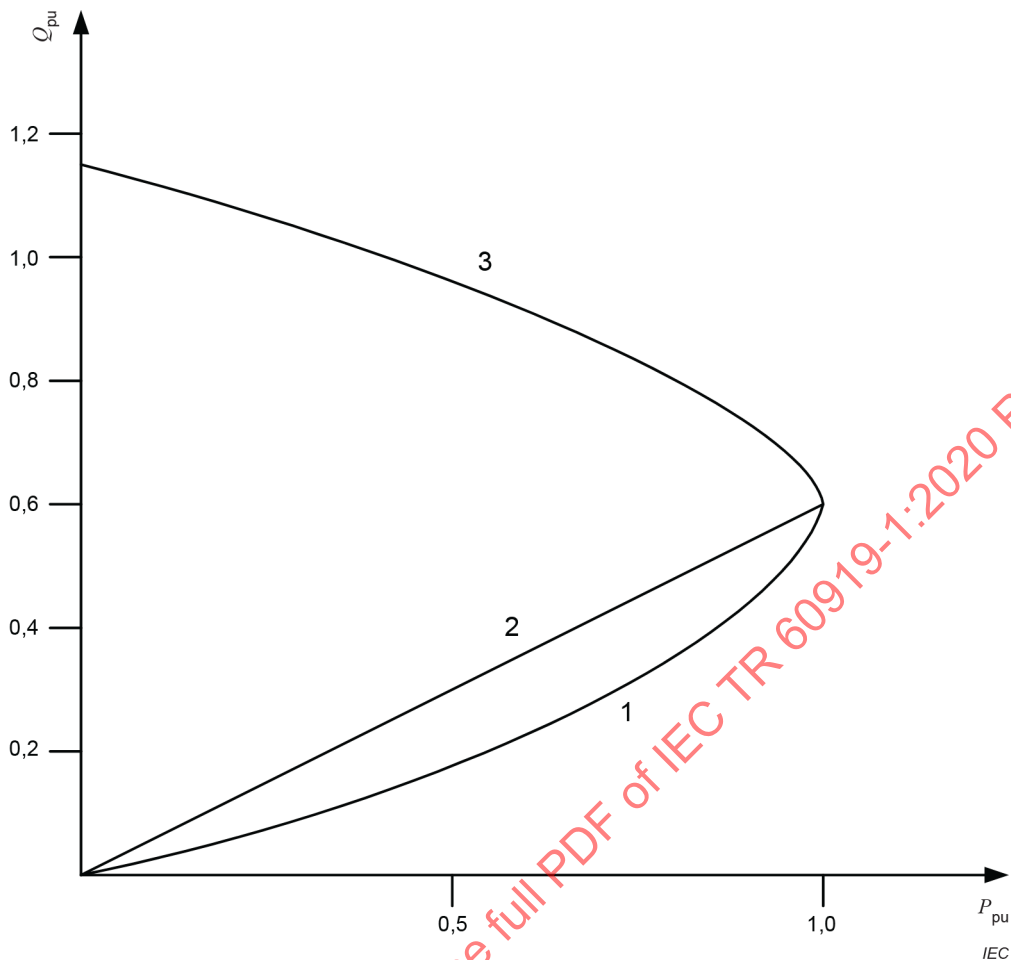
**Key**

- 1 Constant DC voltage – Constant  $\gamma$
- 2 Constant DC voltage – Constant  $U_{d0}$
- 3 Constant DC current

**Figure 19 – Variations of reactive power  $Q$  with active power  $P$  of an HVDC converter**

Combined changes of the valve firing angle and the load tap changer of the converter transformer may be used to control the reactive power demand of an HVDC substation. However, since this requires an increase of the firing angle, it leads to an increased generation of harmonic currents and voltages and increased losses in the damping circuits of the valves.

Looked at another way, filtering of AC current is obtained through harmonic filters, which also generate reactive power. However, the fundamental frequency reactive power generated by the filters as determined by the AC filtering requirements at full load is generally less than the reactive power consumption of the converter bridges. Therefore, additional capacitor banks are usually provided to meet the total reactive power demand of the converter.

The net reactive power of the converters and filters, taking into account filtering consideration, may be controlled within certain limits, by switching of capacitor banks and also part of the filter banks, if needed.

To define a suitable strategy of reactive power control, the aspects described in 10.4 to 10.7 should be specified.

### 10.3 Series capacitor compensated HVDC schemes

Reactive power requirements of conventional HVDC schemes are addressed by adding shunt devices such as shunt capacitors and filters.

Conversely, both CCC and CSCC treat this differently, as instead of connecting capacitor banks in parallel to the converter bus, they are inserted between the transformers and valves (CCC) or between the transformers and the AC network (CSCC). By these configurations, the voltage across the series capacitor adds to the commutation voltage resulting in a wide range of trigger delay angle ( $\alpha$ ) and extinction angle ( $\gamma$ ). This brings about less overlap angle ( $\mu$ ) and thus less reactive power consumption. AC filters are required only for harmonic elimination and not for reactive power support. This reduces the MVar rating of the filter to small values. Unlike the conventional case, neither the CCC nor CSCC configuration requires filter-bank switching for variations in the load over the full range of operation.

### 10.4 Converter reactive power consumption

The reactive power consumption should be determined for the different operating conditions for the rectifier and inverter under partial load, full load and overload conditions. The method of calculation and the parameters used in the calculations should also be specified.

The operating conditions to be considered include: direction of power flow, monopolar earth return, monopolar metallic return, bipolar and reduced direct voltage operation over the specified range of steady-state AC bus voltage.

Also at minimum power transfer with a minimum number of AC filters connected, the ability of the converter valves to operate with increased firing angle/extinction angle can be utilized to minimize the reactive power flow to the AC systems.

### 10.5 Reactive power balance with the AC system

To determine the reactive power sources to be installed, an overall balance of reactive power has to be known. To determine the appropriate reactive power, balance load flow studies may need to be performed. Apart from the reactive power needs of the converters, consideration should be given to the following:

- the power factor range to be maintained in the AC lines for all operating conditions;
- the operating voltage ranges under light and peak load conditions of the AC system;
- reactive power available from nearby generators;
- redundancy requirements.

If the rectifier is directly connected to a power station, the following points should also be considered:

- generator capability over the maximum and minimum permissible operating voltage range;
- tap changer range available in the step-up transformer, and the tap to be used for each development stage;
- reactive power requirement of other loads;
- minimum permissible active power for the generators;
- self-excitation limit of the generators;
- minimum number of generators to be connected.

### 10.6 Reactive power supply

The sources of reactive power supply to meet the set of requirements should include the most economical combination of filters, shunt capacitors, shunt reactors, series capacitors, synchronous and static reactive power compensators that meets the performance criteria. Much of the reactive power should be supplied in the form of filters to meet the harmonic

performance. Under light load conditions, the minimum size of the available filter bank connected can lead to surplus reactive power and consequently excessive steady-state voltage. This can require provision of shunt reactors or use of converter capability to consume greater reactive power.

Shunt capacitor banks are the most economical source for the required remaining reactive power. Synchronous and static reactive power compensators should be considered only if there is a dynamic voltage and/or stability problem (see Clause 9). There can be additional requirements associated with the adjacent AC systems.

### 10.7 Maximum size of switchable VAR banks

Filters and capacitor banks may be divided into small switchable banks. The size of switchable banks depends on:

- a) voltage control requirements over the whole operating range from no load to full load and overload;
- b) acceptable regulation step per switching operation. It should be noted that the regulating effect from switching reactive power banks can be modulated with the help of converter control;
- c) frequency of switching.

When considering combinations of filters and shunt capacitors with synchronous compensators, the filters and shunt capacitors should be limited in size to avoid self-excitation of the synchronous machines.

## 11 HVDC transmission line, earth electrode line and earth electrode

### 11.1 General

Clause 11 identifies those characteristics of the HVDC transmission line, the earth electrode and the earth electrode line that are relevant to the specification of the steady-state performance of the converter, including power line carrier performance and design requirements. It does not provide the information that should be specified for the design of the HVDC transmission line, earth electrode lines or earth electrodes themselves.

Key performance specification data for the HVDC transmission line, the earth electrode line and the earth electrode should be determined in advance.

### 11.2 Overhead line(s)

#### 11.2.1 General

The total length of the line should be given, including details concerning any overhead and cable sections. Details should be provided of any right-of-way joint uses. Particulars of all crossings and parallelisms need to be given to enable assessment of possible electrical interactions and interference. If the exact length is not known, the expected range for this length should be stated.

For bipole and multi-pole lines, information on the spacings between poles and bipoles along the complete route will be needed.

#### 11.2.2 Electrical parameters

The electrical parameters are the following:

- 1) resistance – maximum positive and zero-sequence DC values at minimum current, rated current, maximum overload current with due consideration of the ambient conditions (temperature, radiation, wind velocity, etc.) prevailing during the load condition considered.

Curve of frequency dependence up to the 49<sup>th</sup> harmonic of the fundamental frequency for rated current;

- 2) capacitance – positive and zero-sequence capacitance ( $C_1$  and  $C_0$ );
- 3) inductance – positive and zero-sequence inductance ( $L_1$  and  $L_0$ ), curve of frequency dependence up to the 49<sup>th</sup> harmonic of the fundamental frequency for these.

If the information in 1) to 3) above is not available, as an alternative, the necessary data to enable its calculation could be given. To calculate these parameters, the following data will be required:

- a) conductor size, type, geometry (including the shield wire);
- b) tower outlines, spacing and sag profiles;
- c) soil resistivity along the route;
- d) tower footing resistance;
- e) the worst-case maximum conductor surface gradients to permit calculation of corona effects, for example, if a carrier is to be used;
- f) critical impulse flashover level of insulation.

It is strongly recommended that the HVDC transmission line be adequately shielded from direct lightning strokes for the first 10 km from the HVDC substation and for the HVDC transmission line tower footing resistance to be sufficiently low, for example, less than 10  $\Omega$  up to 25  $\Omega$ .

As a third alternative, in place of sequence components, the information could be provided in the form of self- and mutual impedance between conductors and earth.

### 11.3 Cable line(s)

#### 11.3.1 General

Length of sections or total length should be specified as appropriate. Any restrictions on service conditions imposed by the cable supplier should be stated.

Examples of such restrictions might include:

- a) limitations on polarity reversal;
- b) limitations on discharge rate;
- c) limiting voltage and current ripple level;
- d) limitations on overvoltages and overcurrents.

#### 11.3.2 Electrical parameters

The electrical parameters are the following:

- 1) DC resistance of conductor, maximum value at rated current and at maximum overload current, minimum value at minimum current;
- 2) conductor resistance frequency dependence up to 5 kHz;
- 3) cable sheath resistance and frequency dependence up to 5 kHz;
- 4) inductance and frequency dependence up to 20 kHz;
- 5) capacitance of conductor to sheath;
- 6) capacitance of sheath to earth (armour);
- 7) surge impedance of cable conductor to sheath;
- 8) attenuation characteristics up to 50 kHz.

#### 11.4 Earth electrode line

To evaluate possible transformer saturation effects due to direct current flowing via the station earthing system and earthed neutrals, the earth electrode line length, as well as the length of any part of it which is on the HVDC transmission line towers should be specified.

The earth electrode line resistance – maximum value and ambient temperature assumptions – should be stated.

#### 11.5 Earth electrode

The maximum resistance of the earth electrode relative to the remote earth should be indicated. It should be noted that this resistance may increase with time and environmental and/or load conditions.

### 12 Reliability

#### 12.1 General

The reliability of an HVDC system is the ability to transmit a defined energy within a defined time under specified system and environmental conditions.

The purpose and scope of Clause 12 is for writing specifications and evaluating reliability. Clause 12 defines reliability calculations during the acceptance period of an HVDC system. Please refer to Annex A for more information on factors affecting reliability and availability of converter stations. Reference is made to IEC TR 62672 which deals with a reporting procedure of specific failures and overall availability of HVDC systems in operation. Although the scope of IEC TR 62672 differs from that of this document, the basic terms used and their definitions are common to both documents.

Terms and definitions applicable to the reliability of HVDC systems are given below.

#### 12.2 Outage

##### 12.2.1 General

An outage of the HVDC system is an event when the transmission capability falls to a level below the maximum rated power. This may be caused by defects of components of parts of the equipment, human errors, switching-out of equipment for maintenance and repair, switching-out caused by an operation of protection equipment, external fault, etc. (see 12.3.3). Consideration should be given to defining which of these or other causes should be included in the availability and annual number of forced outages. An outage will be included in the calculations either as a scheduled outage or a forced outage (12.2.2 and 12.2.3, respectively).

##### 12.2.2 Scheduled outage

A scheduled outage is an outage where the transmission capability falls below the rated power level, and is planned in advance to allow part or all of the HVDC system to be taken out of service for a scheduled maintenance period or for equipment repair.

##### 12.2.3 Forced outage

A forced outage is an unscheduled outage, which is initiated either by automated protection equipment action or through operator intervention (i.e. taking a decision to shut down all or part of the HVDC system in a situation where continued operation may cause damage to personnel or equipment and the shutdown cannot be deferred until the next scheduled outage).

## 12.3 Capacity

### 12.3.1 General

The capacity terms defined below are normally defined at one point in the HVDC system (such as the sending-end AC terminals, the receiving-end AC terminals, or the sending-end DC terminals). In cases where each of the HVDC converter terminals are under separate ownership, it may be appropriate to define the rating of each station individually.

### 12.3.2 Maximum continuous capacity $P_m$

This is defined as the maximum power value (in MW) for which the HVDC system is rated for continuous operation, excluding any additional capacity available through the presence of redundant equipment.

### 12.3.3 Outage capacity $P_o$

For the duration of the outage, the power available is reduced from the maximum rating by an amount (in MW) called the outage capacity  $P_o$ .

### 12.3.4 Outage derating factor (ODF)

The outage derating factor is defined as the ratio of the outage capacity  $P_o$  to the maximum capacity  $P_m$ :

Error! Bookmark not defined. 
$$ODF = \frac{P_o}{P_m} \quad (1)$$

## 12.4 Outage duration terms

### 12.4.1 Actual outage duration (AOD)

The actual outage duration is defined as the time elapsed in decimal hours between the start and the end of the outage. The outage is typically started when a switching event takes place to interrupt the main circuit power flow, or to initiate the reduction to the outage power level. The outage is typically completed when a switching event takes place to restore the equipment to a state where it is ready for operation, although not necessarily put into operation, i.e. the equipment is made available for service operation.

The actual outage durations may be segregated into forced and scheduled, such that the value of AOD for each outage becomes either actual forced outage duration (AFOD) or actual scheduled outage duration (ASOD).

### 12.4.2 Equivalent outage duration (EOD)

To take into account the partial loss of capacity, the equivalent outage duration is defined as the actual outage duration multiplied by the outage derating factor

$$EOD = AOD \times ODF \quad (2)$$

Similarly to the creation of forced and scheduled actual outage durations, it is possible to segregate the equivalent outage durations into forced and scheduled to give equivalent forced outage duration (EFOD) and equivalent scheduled outage duration (ESOD).

### 12.4.3 Period hours (PH)

The period hours is the total number of hours in the period covered by the analysis and is typically one year or 8 760 h.

#### 12.4.4 Actual outage hours (AOH)

The actual outage hours are the sum of the individual actual outage durations for the period of the analysis.

$$AOH = \sum AOD \quad (3)$$

It is possible to subdivide the AOH value into forced and scheduled outage hours, by summing the AFOD and ASOD values rather than the summation of the AOD values.

#### 12.4.5 Equivalent outage hours (EOH)

This is defined as the sum of the individual equivalent outage durations within the period of the analysis.

$$EOH = \sum EOD \quad (4)$$

It is possible to subdivide the EOH value into forced and scheduled outage hours by summing the EFOD and ESOD values, rather than the summation of the EOD values.

### 12.5 Energy unavailability (EU)

#### 12.5.1 General

This is a measure of energy which could not have been transmitted due to outages.

Energy unavailability is determined from the equivalent outage hours value, as follows:

$$EU \% = \left( \frac{EOH}{PH} \right) \times 100 \quad (5)$$

It is usually expressed as a percentage.

For reliability studies, it is essential to distinguish between the effects of line faults on monopolar and on multipolar (bipolar) transmission systems.

In a monopolar system, a line fault causes a complete collapse of the transmission. In a bipolar system, for most cases, a line fault only affects one pole of the transmission system, so that line faults would, in general, reduce energy transmission by 50 %. However, if the remaining transmission line pole is designed for some degree of overcurrent capability and if the converter groups on the HVDC substation can be connected in parallel, then more than 50 % of the energy may be transmitted after the necessary switching for paralleling the converters has been performed.

In the case of a fault in a converter unit, the affected unit may have to be switched out. The percentage loss of transmission capacity is given by the number of converter groups taken out of service related to the total number of converter units.

There may be other contingencies, such as partial loss of filters, faulted earth electrode line, etc. Their impact on availability should be defined.

#### 12.5.2 Forced energy unavailability (FEU)

There is a measure of the energy which could not have been transmitted due to forced outages:

$$FEU \% = \left( \frac{EFOH}{PH} \right) \times 100 \quad (6)$$

where *EPOH* means equivalent forced outage hours.

### 12.5.3 Scheduled energy unavailability (SEU)

This is a measure of the energy which could not have been transmitted due to scheduled outages:

$$SEU \% = \left( \frac{ESOH}{PH} \right) \times 100 \quad (7)$$

where *ESOH* means equivalent scheduled outage hours.

### 12.6 Energy availability (EA)

This is a measure of the energy which could have been transmitted by an HVDC system:

$$EA \% = 100 - EU \% \quad (8)$$

### 12.7 Maximum permitted number of forced outages

Not all the forced outages are to be counted. The maximum permitted number of such forced outages for the period hours PH should be defined.

### 12.8 Statistical probability of outages

#### 12.8.1 Component faults

In addition to the availability of the overall system, the reliability of some individual components may also be considered.

Every component in the system can be characterized by its failure rate  $\lambda$ . It is well to distinguish between statistical failures (random outages) and failures at the end of the component lifetime (for example, outages of luminescent diodes because of ageing). To stock spare parts, good practice differentiates between these two kinds of failures, since at the end of their lifetime all of the concerned components should be replaced.

#### 12.8.2 External faults

The expected number of AC system faults and their duration, which may detrimentally influence the behaviour of an HVDC system, should be stated. The probability of the occurrence of such faults should be considered when stating the permitted number of HVDC system forced outages.

## 13 HVDC control

### 13.1 Control objectives

The advantages of an HVDC system very much depend on the utilization of its controllability in ensuring maximum flexibility, reliability and adaptability for different system requirements.

The control system should be able to maintain stable operation of converters and normal power transmission of the HVDC system within the specified range of AC voltage and frequency. The objective of an HVDC control system should be to provide efficient operation

and maximum flexibility of power control in magnitude, rate of change and direction without compromising the safety of the equipment, while maintaining the maximum independence of each pole. The control system should be suitable for high-speed control in such a way that it can effectively respond to disturbances in the AC and HVDC systems. It is recognized that long-distance transmission requires a high-speed telecommunication system for the most effective operation. However, the HVDC system should be operable without telecommunication, and, for this case, the performance should be maximized to the extent possible.

The control system should be adaptable for:

- 1) control of the reactive power exchange with the AC system including reduced or increased reactive power consumption;
- 2) AC voltage control;
- 3) frequency control;
- 4) active power modulation;
- 5) combined active and reactive power modulation;
- 6) subsynchronous torsional interaction damping;
- 7) remote operation;
- 8) coordinated control of converters among two terminals.

## 13.2 Control structure

### 13.2.1 General

The various control circuits of an HVDC substation are generally structured in a hierarchical manner. The main control functions are dispersed to a lower level as far as possible to improve the system reliability and availability. They normally operate fully automatically. For long-distance HVDC transmission systems, a telecommunication link is needed to coordinate between the rectifier and the inverter. The various levels are described subsequently, starting with the lowest level (Figure 20).

### 13.2.2 Converter unit firing control

The converter unit firing control is essentially an open loop control. Its outputs are the firing pulses to the individual valves in a 12-pulse converter unit. These are synchronized to the AC system voltage. The input is the delay angle  $\alpha$  or the trigger advance angle  $\beta$ , as provided by the next higher level.

There are mainly two types of converter unit firing control principles which have been used for HVDC:

- equal delay angle control;
- equidistant firing control.

Equal delay angle control is a method of timing the valve control pulses so that the delay angles of the valves in the converter unit are essentially equal, regardless of unbalances in the AC system voltage.

Equidistant firing control is a method of timing the valve control pulses in such a way that they are essentially equidistant in time, regardless of unbalances or distortion in the AC system voltage.

The function requirements of the converter unit firing control are:

- a) operation down to low values (i.e. fewer than 3) of the ratio between the short-circuit capacity of the AC network and the transmitted DC power;

- b) that the permitted deviation from equidistant firing should be  $\pm\Delta^\circ$ , i.e. each firing during conditions specified shall occur  $30 \pm \Delta^\circ$  after the preceding firing (for a 12-pulse converter unit). It should be noted that the conditions are different with regard to a reasonable value for  $\Delta^\circ$  for different converter modes of operation, i.e. operation with minimum  $\alpha$ , current control or minimum extinction angle control.

Deviation from equidistant firing gives rise to non-characteristic harmonics transferred to the AC network as well as to the HVDC transmission line. A typical permitted maximum value of  $\Delta^\circ$  is  $0,2^\circ$ , assuming that the AC system voltage and impedances are balanced.

### 13.2.3 Pole control

The pole control provides the reference values per pole for all series-connected converter units, if any.

Pole control is a closed loop control and includes the basic control functions that are required for stable operation of the HVDC system, such as current control, voltage control, extinction angle control, power control, tap changer control. All these control functions have a reference value and an actual value. Some of these reference values may be provided by the pole control (for example, the current reference value, which is calculated out of the requested transmission power), others can be provided by the operator (for example, DC voltage, DC power).

Generally, each substation pole is provided with a pole control (Figure 20) that controls the DC voltage output of the converter by determining the firing instant of the valves. The pole control senses the difference between the order and the response and adjusts the converter DC output voltage accordingly. If the current order in the rectifier is larger than the current response, the firing control increases the direct voltage by decreasing the delay angle, thus increasing the direct current. The direct voltage is increased until the current response equals the current order or the maximum voltage is reached when firing at minimum delay angle, (minimum voltage between the terminals of the valve at which the valve will fire correctly). On the other hand, if the current response is larger than the current order, the direct voltage is correspondingly decreased. The decreasing action is limited when the converter operation has been transferred from rectification to inversion and firing given the least permitted extinction angle (to ensure safe valve recovery).

The typical voltage current characteristics of a rectifier and an inverter are shown in Figure 21 a) and Figure 21 b).

Normally, the maximum voltage limit in the inverter is lower than that of the rectifier, and the current will be controlled by the rectifier. That is, the inverter will maintain the voltage, and the rectifier will adjust its voltage until the current becomes equal to the order input, and a stable working point A is established (Figure 21 a).

If the inverter voltage limit is larger than the rectifier voltage limit, the inverter controls the current and the rectifier maintains a maximum voltage. As Figure 21 a) and Figure 21 b) show the control characteristic in a simplified form, typical examples of more detailed characteristics are shown in Figure 21 c).

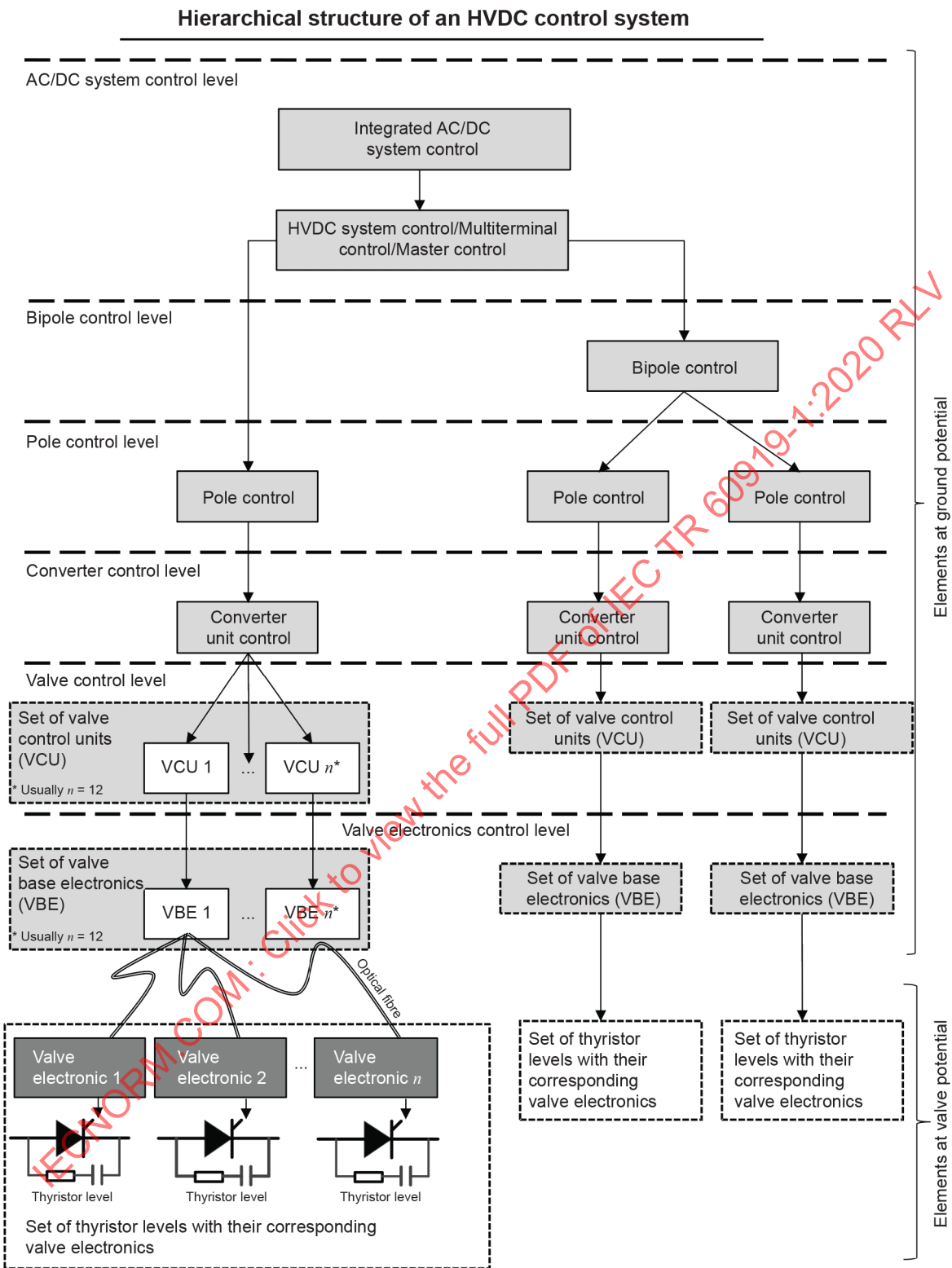

**Figure 20 – Control hierarchy for HVDC/UHVDC system**

As noted, the rectifier usually controls the current and the inverter determines the voltage. The inverter current order equals the rectifier current order less the "current margin" ( $\Delta I = I_R - I_I$ ) (Figure 21 a). The inverter is forced to fire at the lowest allowed trigger advance angle  $\beta$  keeping the extinction angle constant at  $\gamma_{min}$ , and, accordingly, the inverter establishes the voltage on the HVDC transmission line.

For long-distance transmission, the DC voltage at the inverter is usually kept constant by appropriate control of the inverter transformer tap changers. Alternatively, the inverter establishes constant DC voltage by controlling the extinction angle.

For converters connected in series, voltage balance control of valve groups should be applied.

In other systems, the inverter is controlled in such a way as to keep the HVDC transmission line voltage constant. In this case, the transformer tap changer is used to keep the extinction angle  $\gamma$  within a certain range.

The delay angle in the rectifier is kept within a narrow band (nominal  $\alpha \pm \Delta\alpha$ ) by means of adjustment of the tap changers of the converter transformers. DC voltage variation by changing the delay angle by  $\Delta\alpha$  normally corresponds to one tap-changer step. Alternatively, the converter no-load direct voltage may be kept constant by means of adjustment of the tap changers.

Reduced DC voltage may be needed, for example, at times of reduced voltage withstand capability of the HVDC transmission line. This can be accomplished in the rectifier as well as in the inverter by tap change in the converter transformer, by adjustment of the delay angle or by switching off one series connected converter groups, if any.

#### 13.2.4 HVDC substation control

The HVDC substation control is normally implemented as a closed loop control system. One major design criterion for HVDC systems is normally to minimize the equipment at the station level as much as possible, in order to minimize the impact on the bipole in case of a fault at that level. Referring to station level functions, these could also be realized within pole level hardware, and may include:

- a) coordination of current orders between the two ends via the telecommunication link, most likely on a per-pole basis;
- b) power control;
- c) coordination between the poles of an HVDC substation (if there is more than one pole);
- d) additional controls such as frequency control, run up/runback control, power oscillation damping, etc.;
- e) more sophisticated control strategies.

Examples of the more sophisticated control strategies are described below.

The reactive power consumption of an HVDC substation is dependent upon the firing angle and the direct current flowing. Thus the DC link can be used for control of reactive power or for voltage control in the AC network.

The HVDC substation control can be coordinated with control external to the HVDC substation, for example, the turbine governor of a generator station. The HVDC substation can also be provided with controls to avoid subsynchronous torsional interaction (SSTI) of a turbine-generator.

Pole current balance control can be specified to minimize earth electrode line current (equal to the unbalance current between two poles of a bipolar earth return HVDC system), to avoid corrosion problems from earth current flow through underground structures. A typical unbalance current limit between the two poles of a bipolar system without balance control might be 3 % of rated current.

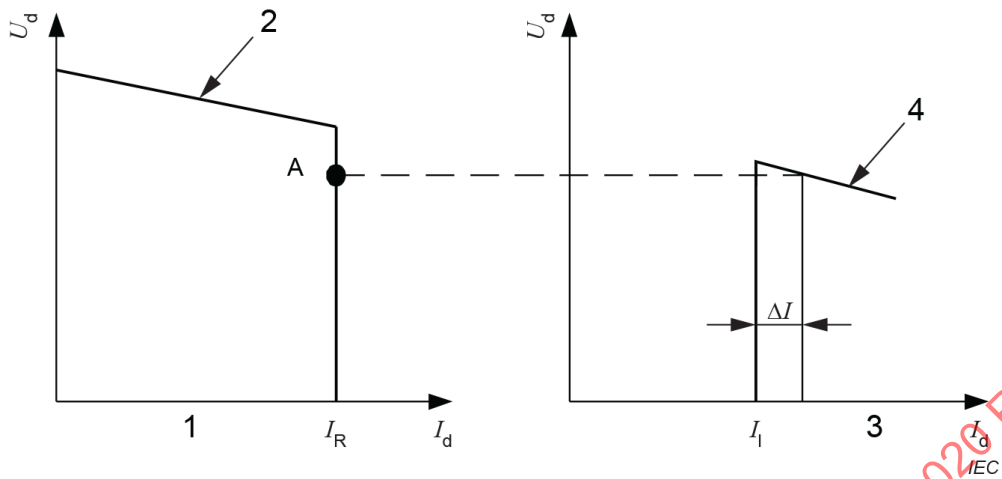

a) Normal operation, rectifier controls the current

**Key**

- |   |   |   |  |
|---|---|---|--|
| 1 | Rectifier                                   | 3 | Inverter                                   |
| 2 | Rectifier firing at $\alpha = \alpha_{min}$ | 4 | Inverter firing at $\gamma = \gamma_{min}$ |

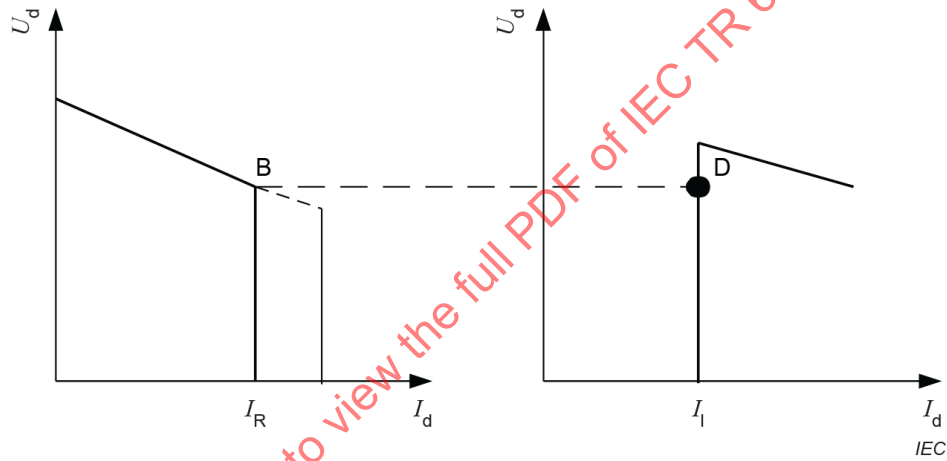

b) Inverter controls the current

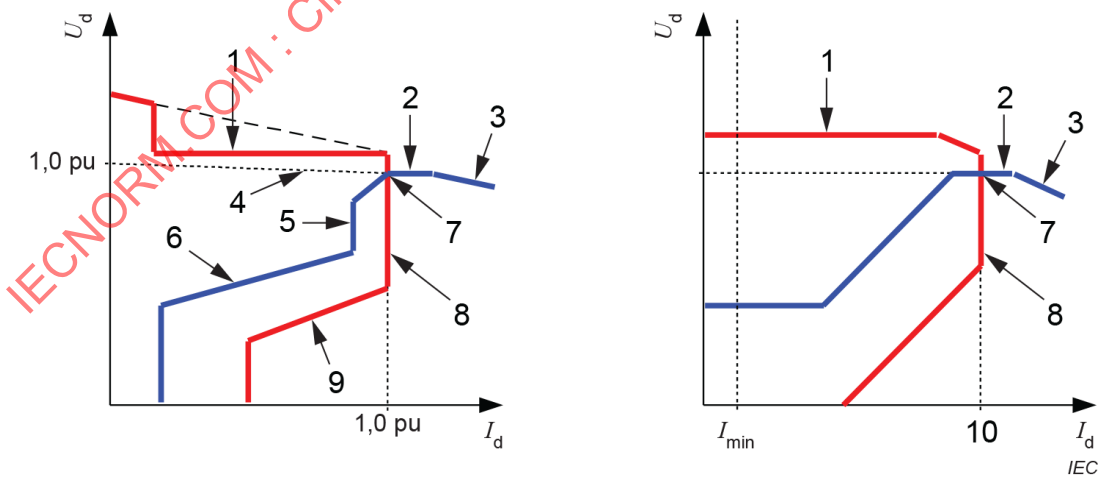

c) Examples of HVDC control characteristic

**Key**

- |   |  |    |  |
|---|--|----|--|
| 1 | Rectifier $U_d$ control                | 6  | Inverter VDCL (voltage-dependent current limit)  |
| 2 | Inverter $U_d$ control (voltage order) | 7  | Normal operating point                           |
| 3 | Inverter $\gamma$ control              | 8  | Rectifier $I_d$ control                          |
| 4 | DC line drop                           | 9  | Rectifier VDCL (voltage-dependent current limit) |
| 5 | Inverter $I_d$ control                 | 10 | Current order                                    |

**Figure 21 – Converter voltage-current characteristic**

It should be specified which control strategies are intended to be used and at which priority they should be operable under different operating and AC system conditions.

The power control tolerance is dependent upon the accuracy of the voltage divider, the current sensor and the resolution of the power order. A typical tolerance value is about 1,5 % at rated power.

### 13.2.5 Master control

Master control is usually integrated into the HVDC station control. However, if two or more HVDC substations are connected to the same AC bus, the master control would be a separate level above the station control and include more sophisticated control strategies. It would interface with the AC system and coordinate the various substations. Master control can also be provided remotely, for example, at a dispatch centre. In this case, telecommunication shall be provided from the dispatch centre to the HVDC substation.

### 13.3 Control order settings

Generally, both converters of an HVDC system are equipped with identical control equipment since most HVDC systems are designed to transmit power in both directions.

Only the station control in one location can be in the lead at one time. Generally, the setting of the station control order and rate of change are provided manually at the lead station. The changes in order are then executed in the other substation(s) via the telecommunication. Capability of the lead station for setting can also be transferred to a remote location, for example, a dispatch centre.

In the current control mode the current order can be set manually in both substations, if voice communication is available for coordination purposes. Current control can also be provided remotely, for example, at a dispatch centre.

Switching from power to current control mode may be ordered automatically after failure of the telecommunication channel or by command from the station control.

The resolution in the power order setting may be specified (typically 10 MW at a rated power of 1 000 MW). Its rate of change may be specified as well (for example, between 1 MW/min and 99 MW/min in steps of 1 MW/min).

Change in power direction is normally initiated from the lead substation, but could also be ordered automatically, if emergency reversal is called for, for example, after a disturbance in one of the AC systems.

### 13.4 Current limits

Various limits can be applied to the current order. The main objective of these is to optimize the permissible current with respect to main circuit components and cooling conditions. Examples of such limits are:

- a) overload of limited duration – permits overload for a fixed duration per 24 h period, for example, to take account of transformer temperature-rise limits;
- b) winter overload – permits overload when valve cooling conditions are favourable during low ambient temperature periods;
- c) dynamic overload – permits overload for short times based on transient thermal properties of thyristors and their coolers;
- d) other current limitation – because of loading limits for generators connected to the rectifier substation or for operation with reduced DC voltage or other system dynamic performance requirements;
- e) minimum current limitation – normally 0,05 to 0,1 per unit.