

# TECHNICAL REPORT



**Optical amplifiers –  
Part 4: Maximum permissible optical power for the damage-free and safe use of  
optical amplifiers, including Raman amplifiers**

IECNORM.COM : Click to view the full PDF of IEC TR 61292-4:2023 RLV



## THIS PUBLICATION IS COPYRIGHT PROTECTED

Copyright © 2023 IEC, Geneva, Switzerland

All rights reserved. Unless otherwise specified, no part of this publication may be reproduced or utilized in any form or by any means, electronic or mechanical, including photocopying and microfilm, without permission in writing from either IEC or IEC's member National Committee in the country of the requester. If you have any questions about IEC copyright or have an enquiry about obtaining additional rights to this publication, please contact the address below or your local IEC member National Committee for further information.

IEC Secretariat  
3, rue de Varembe  
CH-1211 Geneva 20  
Switzerland

Tel.: +41 22 919 02 11  
[info@iec.ch](mailto:info@iec.ch)  
[www.iec.ch](http://www.iec.ch)

### About the IEC

The International Electrotechnical Commission (IEC) is the leading global organization that prepares and publishes International Standards for all electrical, electronic and related technologies.

### About IEC publications

The technical content of IEC publications is kept under constant review by the IEC. Please make sure that you have the latest edition, a corrigendum or an amendment might have been published.

#### IEC publications search - [webstore.iec.ch/advsearchform](http://webstore.iec.ch/advsearchform)

The advanced search enables to find IEC publications by a variety of criteria (reference number, text, technical committee, ...). It also gives information on projects, replaced and withdrawn publications.

#### IEC Just Published - [webstore.iec.ch/justpublished](http://webstore.iec.ch/justpublished)

Stay up to date on all new IEC publications. Just Published details all new publications released. Available online and once a month by email.

#### IEC Customer Service Centre - [webstore.iec.ch/csc](http://webstore.iec.ch/csc)

If you wish to give us your feedback on this publication or need further assistance, please contact the Customer Service Centre: [sales@iec.ch](mailto:sales@iec.ch).

#### IEC Products & Services Portal - [products.iec.ch](http://products.iec.ch)

Discover our powerful search engine and read freely all the publications previews. With a subscription you will always have access to up to date content tailored to your needs.

#### Electropedia - [www.electropedia.org](http://www.electropedia.org)

The world's leading online dictionary on electrotechnology, containing more than 22 300 terminological entries in English and French, with equivalent terms in 19 additional languages. Also known as the International Electrotechnical Vocabulary (IEV) online.

IECNORM.COM : Click to view the full PDF of IEC TR 61992-4:2023 RLV

# TECHNICAL REPORT



**Optical amplifiers –**

**Part 4: Maximum permissible optical power for the damage-free and safe use of optical amplifiers, including Raman amplifiers**

INTERNATIONAL  
ELECTROTECHNICAL  
COMMISSION

ICS 33.160.10; 33.180.30

ISBN 978-2-8322-6365-5

**Warning! Make sure that you obtained this publication from an authorized distributor.**

## CONTENTS

|  |               |
|--|---------------|
| FOREWORD.....  | 4             |
| INTRODUCTION.....  | 2             |
| 1 Scope <del>and object</del> .....  | 8             |
| 2 Normative references .....   | 8             |
| 3 Terms, definitions, and abbreviated terms .....  | 9             |
| 3.1 Terms and definitions.....   | 9             |
| 3.2 Abbreviated terms.....   | 8             |
| 4 Maximum transmissible optical power to keep fibres damage-free .....   | 9             |
| 4.1 General.....   | 9             |
| 4.2 Fibre fuse and its propagation.....  | 10            |
| 4.3 Loss-induced heating at connectors or splices .....  | 11            |
| 4.4 Connector endface damage induced by dust/contamination .....   | 12            |
| 4.5 Fibre coat burn/melt induced by tight fibre bending .....  | 15            |
| 4.6 Summary of the fibre damage .....  | 16            |
| 5 Maximum transmissible optical power to keep eyes and skin safe .....   | 16            |
| 5.1 Maximum transmissible exposure (MPE) on the surface of eye and skin .....  | 16            |
| 5.2 Maximum permissible optical power in the fibre for the safety of eye and skin.....   | 17            |
| <del>5.2.1 General .....</del>   | <del>17</del> |
| 5.2.1 Power limit.....   | 17            |
| 5.2.2 Need for APR .....   | 18            |
| 5.2.3 Wavelengths.....   | 19            |
| 5.2.4 Locations.....   | 19            |
| 5.2.5 Nominal ocular hazard distance (NOHD).....   | 19            |
| 5.2.6 Power reduction times .....  | 19            |
| 5.2.7 Medical aspects of the safety of eyes and skin in existing standards .....   | 21            |
| 6 Maximum optical power permissible for optical amplifiers from the viewpoint of fibre damage as well as eye and skin safety ..... | 22            |
| 7 Conclusion .....   | 22            |
| Annex A (informative) General information for optical fibre fuse .....   | 23            |
| A.1 Introductory remark.....   | 23            |
| A.2 Generating mechanism .....   | 23            |
| A.3 Void formation mechanism .....   | 27            |
| A.4 Propagation characteristic of a fibre fuse .....   | 27            |
| A.5 Prevention and termination .....   | 29            |
| A.5.1 General .....  | 29            |
| A.5.2 Prevention methods .....   | 29            |
| A.5.3 Termination methods .....  | 30            |
| A.6 Additional safety information .....  | 32            |
| A.7 Conclusion.....  | 33            |
| Bibliography.....  | 34            |
| Figure 1 – Experimental set-up for fibre fuse propagation .....  | 10            |
| Figure 2 – Connection loss versus temperature increase .....   | 12            |
| Figure 3 – Test set-up.....  | 13            |
| Figure 4 – Surface condition contaminated with metal filings, before the test .....  | 14            |

|   |    |
|---|----|
| Figure 5 – Variation of power attenuation during test at several power input values for plugs contaminated with metal filings .....                           | 14 |
| Figure 6 – Polishing surface condition contaminated with metal filing, after test .....   | 14 |
| Figure 7 – Thermo viewer image of tightly bent SMF with optical power of 3 W at 1 480 nm .....  | 15 |
| Figure 8 – Temperature of the coating surface of SMFs against bending with optical power of 3 W at 1 480 nm .....   | 16 |
| Figure 9 – Maximum permissible power in the fibre against APR power reduction time .....  | 21 |
| Figure A.1 – Front part of the fibre fuse damage generated in the optical fibre.....  | 23 |
| Figure A.2 – SiO absorption model .....   | 25 |
| Figure A.3 – Calculated fibre fuse propagation behaviour simulated with the SiO absorption model .....  | 26 |
| Figure A.4 – Series of optical micrographs showing damage generated by 9,0 W 1 480 nm laser light suggesting a mechanism of periodic void formation.....      | 27 |
| Figure A.5 – Images of fibre fuse ignition taken with an ultra-high-speed camera and an optical micrograph of the damaged fibre.....                          | 28 |
| Figure A.6 – Power density dependence of the fibre-fuse propagation velocity .....  | 29 |
| Figure A.7 – Optical micrographs showing front part of the fibre fuse damage generated in SMF-28 fibres with various laser intensities (1 480 nm).....        | 29 |
| Figure A.8 – Principle of the optical fibre fuse passive termination method and photograph of a fibre fuse terminator using a TEC structure.....              | 30 |
| Figure A.9 – Photograph of hole-assisted fibre and fibre fuse termination using a hole-assisted fibre .....   | 31 |
| Figure A.10 – Example of fibre fuse active termination scheme.....  | 32 |
| Figure A.11 – Transformation of electrical signal by optical fibre fuse .....   | 32 |
| <br>  |    |
| Table 1 – Threshold power of fibre fuse propagation for various fibres.....   | 10 |
| Table 2 – Measurement conditions.....   | 12 |
| Table 3 – Examples of power limits for optical fibre communication systems having automatic power reduction to reduce emissions to a lower hazard level ..... | 17 |
| Table 4 – Location types within an optical fibre communication system and their typical installations .....   | 19 |

IECNORM.COM · Click to view the full PDF on IEC TR 61292-4:2023 RLV

## INTERNATIONAL ELECTROTECHNICAL COMMISSION

### OPTICAL AMPLIFIERS –

#### **Part 4: Maximum permissible optical power for the damage-free and safe use of optical amplifiers, including Raman amplifiers**

#### FOREWORD

- 1) The International Electrotechnical Commission (IEC) is a worldwide organization for standardization comprising all national electrotechnical committees (IEC National Committees). The object of IEC is to promote international co-operation on all questions concerning standardization in the electrical and electronic fields. To this end and in addition to other activities, IEC publishes International Standards, Technical Specifications, Technical Reports, Publicly Available Specifications (PAS) and Guides (hereafter referred to as "IEC Publication(s)"). Their preparation is entrusted to technical committees; any IEC National Committee interested in the subject dealt with may participate in this preparatory work. International, governmental and non-governmental organizations liaising with the IEC also participate in this preparation. IEC collaborates closely with the International Organization for Standardization (ISO) in accordance with conditions determined by agreement between the two organizations.
- 2) The formal decisions or agreements of IEC on technical matters express, as nearly as possible, an international consensus of opinion on the relevant subjects since each technical committee has representation from all interested IEC National Committees.
- 3) IEC Publications have the form of recommendations for international use and are accepted by IEC National Committees in that sense. While all reasonable efforts are made to ensure that the technical content of IEC Publications is accurate, IEC cannot be held responsible for the way in which they are used or for any misinterpretation by any end user.
- 4) In order to promote international uniformity, IEC National Committees undertake to apply IEC Publications transparently to the maximum extent possible in their national and regional publications. Any divergence between any IEC Publication and the corresponding national or regional publication shall be clearly indicated in the latter.
- 5) IEC itself does not provide any attestation of conformity. Independent certification bodies provide conformity assessment services and, in some areas, access to IEC marks of conformity. IEC is not responsible for any services carried out by independent certification bodies.
- 6) All users should ensure that they have the latest edition of this publication.
- 7) No liability shall attach to IEC or its directors, employees, servants or agents including individual experts and members of its technical committees and IEC National Committees for any personal injury, property damage or other damage of any nature whatsoever, whether direct or indirect, or for costs (including legal fees) and expenses arising out of the publication, use of, or reliance upon, this IEC Publication or any other IEC Publications.
- 8) Attention is drawn to the Normative references cited in this publication. Use of the referenced publications is indispensable for the correct application of this publication.
- 9) Attention is drawn to the possibility that some of the elements of this IEC Publication may be the subject of patent rights. IEC shall not be held responsible for identifying any or all such patent rights.

**This redline version of the official IEC Standard allows the user to identify the changes made to the previous edition IEC TR 61292-4:2014. A vertical bar appears in the margin wherever a change has been made. Additions are in green text, deletions are in strikethrough red text.**

IEC TR 61292-4 has been prepared by subcommittee 86C: Fibre optic systems and active devices, of IEC technical committee 86: Fibre optics. It is a Technical Report.

This fourth edition cancels and replaces the third edition published in 2014. This edition constitutes a technical revision.

This edition includes the following significant technical changes with respect to the previous edition.

- a) The technical information has been updated to reflect revisions of the relevant references.
- b) In particular, the descriptions provided in Clause 5 and Clause 6 have been modified significantly to reflect changes in the cited references. Unnecessary formulas and explanations that overlap with the references have been removed to simplify the document.
- c) New information has been added to Annex A on optical fibre burning when light enters an optical fibre with a bubble train formed by a fibre fuse.

The text of this Technical Report is based on the following documents:

| Draft        | Report on voting |
|--------------|------------------|
| 86C/1821/DTR | 86C/1832/RVDTR   |

Full information on the voting for its approval can be found in the report on voting indicated in the above table.

The language used for the development of this Technical Report is English.

This document was drafted in accordance with ISO/IEC Directives, Part 2, and developed in accordance with ISO/IEC Directives, Part 1 and ISO/IEC Directives, IEC Supplement, available at [www.iec.ch/members\\_experts/refdocs](http://www.iec.ch/members_experts/refdocs). The main document types developed by IEC are described in greater detail at [www.iec.ch/standardsdev/publications](http://www.iec.ch/standardsdev/publications).

A list of all parts in the IEC 61292 series, published under the general title *Optical amplifiers* can be found on the IEC website.

The committee has decided that the contents of this document will remain unchanged until the stability date indicated on the IEC website under [webstore.iec.ch](http://webstore.iec.ch) in the data related to the specific document. At this date, the document will be

- reconfirmed,
- withdrawn,
- replaced by a revised edition, or
- amended.

**IMPORTANT – The "colour inside" logo on the cover page of this document indicates that it contains colours which are considered to be useful for the correct understanding of its contents. Users should therefore print this document using a colour printer.**

## INTRODUCTION

This document is dedicated to the subject of maximally permissible optical power for damage-free and safe use of optical amplifiers, including Raman amplifiers. Since the technology is quite new and still evolving, amendments and new editions to this document can be expected.

Many new types of optical amplifiers are entering the marketplace, and research is also stimulating the development of many new types of fibre and non-fibre based optical amplifiers. With the introduction of new technologies, such as long-haul, ~~over 40~~ beyond 100 Gb/s, WDM transmission, digital coherent transmission and Raman amplification, some optical amplifiers ~~may involve~~ employ optical pump sources with extremely high optical power – possibly up to several Watts. For example, erbium doped fibre amplifiers that provide extremely high output power are described in IEC TR 61292-8 [1]<sup>1</sup>, and Raman amplifiers in IEC TR 61292-6 [2].

Excessively high optical power ~~may~~ can cause physical damage to the ~~fibres~~ optical fibres, components and equipment, in addition to presenting a medical ~~danger~~ hazard to the human eye and skin.

The possibility of fibre damage caused by high optical intensity has been discussed at technical conferences and in technical reports for many years. ~~The use of high intensity optical amplifiers may cause problems in the fibre such as a fibre fuse, a heating in the splice point (connection point), and the fibre end face damage due to dust and the fibre coat burning due to tight fibre bending. IEC SC 86A (Fibres and cables) has published IEC TR 62547, and SC 86B (Fibre optic interconnecting devices and passive components) has published IEC TR 62627-01. IEC TC 31 (Equipment for explosive atmospheres) is also discussing the risk of ignition of hazardous environments by radiation from optical equipment.~~ The use of high intensity optical amplifiers can cause problems in optical fibres, which include fibre fuse, heating in the splice points (connection points), fibre endface damage due to dust, and fibre coat burning due to tight fibre bending. For example, IEC TR 62547 [3] provides guidelines for the measurement of high-power damage sensitivity of single-mode fibre to bends, and IEC TR 62627-01 [4] describes cleaning methods for fibre optic connectors to reduce the risk of fibre endface damage. In addition, other standard groups are discussing the risk of ignition of hazardous environments caused by high-power radiation from optical equipment.

~~Medical aspects have long been discussed at standards groups. IEC TC 76 (Optical radiation safety and laser equipment) precisely describes in IEC 60825-2 the concept of hazard level and labelling and addresses the safety aspects of lasers specifically in relation to tissue damage.~~

~~ITU-T Study Group 15 (Optical and other transport networks) has published Recommendation G.664, which primarily discusses the automatic laser power reduction functionality for safety.~~

The medical aspects of high-power optical radiation have also been addressed by standards. IEC 60825-2 defines the concept of hazard levels and corresponding labelling, which addresses the safety aspects of lasers specifically in relation to tissue damage.

In addition, IEC TR 60825-17 [5] describes safety measures to protect against effects caused exclusively by thermal, opto-mechanical and related effects in passive optical components and optical cables used in high power optical fibre communication systems. Moreover, ITU-T Recommendation G.664 [6] discusses the safety feature of automatic laser power reduction.

With the recently growing interest in high power fibre amplifiers and fibre Raman amplifiers, however, some difficulties have been identified among optical amplifier users and manufacturers in fully understanding the technical details and requirements across all such standards and agreements.

---

<sup>1</sup> Numbers in square brackets refer to the Bibliography.

This document provides a simple informative guideline on the maximum optical power permissible for optical amplifiers for optical amplifier users and manufacturers.

IECNORM.COM : Click to view the full PDF of IEC TR 61292-4:2023 RLV

## OPTICAL AMPLIFIERS –

### Part 4: Maximum permissible optical power for the damage-free and safe use of optical amplifiers, including Raman amplifiers

#### 1 ~~Scope and object~~

This part of IEC 61292, which is a Technical Report, applies to all commercially available optical amplifiers (OAs), including optical fibre amplifiers (OFAs) using active fibres as well as Raman amplifiers. Semiconductor optical amplifiers (SOAs) using semiconductor gain media are also included.

This document provides informative guidelines on the threshold of high optical power that ~~causes~~ can cause high-temperature damage of the fibre. Also discussed is optical safety for manufacturers and users of optical amplifiers by ~~reiterating substantial~~ quoting parts of existing standards and agreements on eye and skin safety.

~~To identify the maximum permissible optical power in the optical amplifier from damage-free and safety viewpoints,~~ This document identifies the following values for maximum permissible optical power in the optical amplifier for damage-free and safe operation:

- a) the optical power limit that causes thermal damage to the fibre, such as fibre fuse and fibre-coat burning;
- b) the maximum permissible exposure (MPE) to which the eyes/skin can be exposed without consequent injury;
- c) the optical power limit in the fibre that causes MPE on the eyes/skin after free-space propagation from the fibre;
- d) the absolute allowable optical power level for damage-free and safe ~~level of optical power~~ operation of the optical amplifier by comparing a) and c).

The objective of this document is to minimize potential confusion and misunderstanding in the industry that ~~might~~ can cause unnecessary alarms and hinder the progress and acceptance of advancing optical amplifier technologies in the market.

It is important ~~to point out~~ that the reader ~~should~~ always refers to the latest international standards and agreements, because the technologies concerned are rapidly evolving.

The present document will be frequently reviewed and updated in a timely manner by incorporating the results of various studies related to OAs and OA-supported optical systems.

#### 2 Normative references

The following documents are referred to in the text in such a way that some or all of their content constitutes requirements of this document. For dated references, only the edition cited applies. For undated references, the latest edition of the referenced document (including any amendments) applies.

~~IEC 60825-1:2007, Safety of laser products – Part 1: Equipment classification and requirements~~

~~IEC 60825-2:2004, Safety of laser products – Part 2: Safety of optical fibre communication systems (OFCS)~~  
~~Amendment 1 (2006)~~  
~~Amendment 2 (2010)~~

~~IEC TR 60825-14:2004, Safety of laser products – Part 14: A user's guide~~

~~IEC TR 62547, Guidelines for the measurement of high-power damage sensitivity of single-mode fibres to bends – Guidance for the interpretation of results~~

~~IEC TR 62627-01, Fibre optic interconnecting devices and passive components – Part 01: Fibre optic connector cleaning methods~~

~~ITU-T Recommendation G.664:2012, Optical safety procedures and requirements for optical transport systems~~

IEC 61291-1:2018, *Optical amplifiers – Part 1: Generic specification*

### 3 Terms, definitions, and abbreviated terms

#### 3.1 Terms and definitions

For the purposes of this document, the terms and definitions given in IEC 61291-1:2018 apply.

ISO and IEC maintain terminological databases for use in standardization at the following addresses:

- IEC Electropedia: available at <http://www.electropedia.org/>
- ISO Online browsing platform: available at <http://www.iso.org/obp>

#### 3.2 Abbreviated terms

|        |  |
|--------|--|
| ALS    | automatic laser shutdown   |
| APR    | automatic power reduction  |
| DSF    | dispersion shifted fibre   |
| LOS    | loss of signal   |
| MFD    | mode field diameter  |
| MPE    | maximum permissible exposure                                     |
| MPI-R  | single channel receive main path Interface reference point       |
| MPI-S  | single channel source main path interface reference point        |
| NOHD   | nominal ocular hazard distance                                   |
| NZ-DSF | non-zero dispersion shifted single-mode <del>optical</del> fibre |
| OA     | optical amplifier  |
| OFA    | optical fibre amplifier  |
| OFCS   | optical fibre communication system                               |
| SMF    | single-mode fibre  |
| SOA    | semiconductor optical amplifier                                  |

### 4 Maximum transmissible optical power to keep fibres damage-free

#### 4.1 General

The use and reasonably foreseeable misuse of high intensity optical amplifiers ~~may~~ can cause problems in the fibre such as

- a) fibre fuse and its propagation,
- b) heating in splice points/connection points,

- c) fibre endface damage due to dust and other contamination, and
- d) fibre coat burning and ignition of hazardous environments due to tight fibre bending or breakage.

Subclauses 4.2 to 4.5 introduce results concerning the above issues to give guidelines for the damage-free use of optical amplifiers. However, ~~it should be noted that~~ the following results are only valid under the conditions tested, and a higher power ~~might~~ could be ~~allowed~~ applied under different conditions.

#### 4.2 Fibre fuse and its propagation

The safety of optical amplifiers ~~should be~~ is discussed from the viewpoint of laser hazard to the eyes and skin and ~~from the viewpoint of~~ fibre damage such as fibre-coat burning and fibre-fusing. Subclause 4.2 experimentally analyses the fibre fuse and its propagation caused by high optical power and discusses the threshold power of fibre fuse propagation [7]. Fibre fuse is defined as the phenomenon in which an intense blue-white flash occurs and runs along the fibre toward the high-power light source while forming periodic and/or non-periodic voids.

Figure 1 shows a typical measurement set-up for ~~measuring~~ the threshold power of fibre fuse propagation. The fibre fuse is initiated by heating the optical fibre from outside of the fibrewith an independent heat source, while ~~a light at~~ high optical power is continuously launched into the fibre. Once the fibre fuse begins propagating, the optical source power is continuously reduced until the fuse propagation ~~stopped for measuring the threshold power~~ stops. Table 1 shows the threshold powers which were measured at various wavelengths of the high-power optical source ~~and for various fibres~~. Although the threshold power depends on the wavelength of the high-power optical source, the power for the fuse propagation is less than 1,4 W and 1,2 W for a standard single-mode fibre (SMF) and a dispersion shifted fibre (DSF) respectively, which are used as the optical fibre for typical optical fibre communication systems.

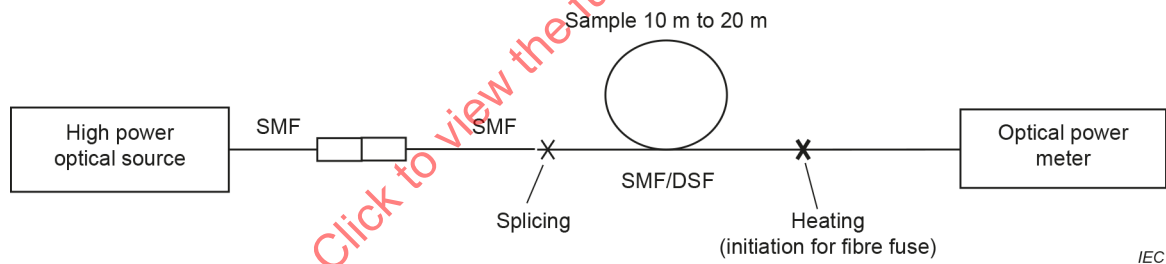

Figure 1 – Experimental set-up for fibre fuse propagation

Table 1 – Threshold power of fibre fuse propagation for various fibres

| Fibre type                    | Measurement wavelength<br>µm | Threshold power of fibre fuse propagation<br>W |
|-------------------------------|------------------------------|--|
| Standard single-mode fibre    | 1,064                        | 1 [8]  |
|                               | 1,467                        | 1,4 [8]  |
|                               | 1,48                         | ~1,2 [9]                                       |
|                               | 1,55                         | 1,39 [10]                                      |
| Dispersion shifted fibre      | 1,064                        | 1,2 [8]  |
|                               | 1,467                        | 0,65 [8]                                       |
|                               | 1,55                         | ~1,1 [11]                                      |
| Dispersion compensation fibre | 1,55                         | ~0,7 [11]                                      |

The difference in fibre mode-field diameter has been identified as the major reason for the difference in the threshold powers because the fibre fuse depends on the power density [7], [8].

~~On the other hand, it is difficult to identify the threshold powers for the fibre fuse self-initiation (without any external cause) because it varied significantly, although they well exceeded 1,4 W and 1,2 W for standard singlemode fibre (SMF) and dispersion shifted fibre (DSF) respectively.~~

On the other hand, it is difficult to identify the threshold power for self-initiated fibre fuse (without any external cause) because it varies significantly. The threshold powers for self-initiated fibre fuse significantly exceed 1,4 W and 1,2 W for standard single-mode fibre (SMF) and dispersion shifted fibre (DSF) respectively.

Further information on the generating mechanism, the characteristics of fibre fuse and the prevention and termination of the fibre fuse are described in Annex A.

### 4.3 Loss-induced heating at connectors or splices

In extremely high-power optical amplifiers, the loss-induced heating at fibres and connectors or splices could lead to damage, including fibre-coat burning, fibre fuse, etc. Subclause 4.2 provides experimental data and considerations for the information of the thermal effects induced by connector and splice losses in high-power amplifiers [12].

Figure 2 shows temperature increase versus connection loss when measured by the conditions shown in Table 2. MU type optical connectors (IEC 61754-6 series [13]) for standard single-mode fibre (SMF) and dispersion shifted fibre (DSF) were used for this measurement. The connector loss was increased by optical fibre misalignment. The optical source used was a 2 W Raman pump at 1 480 nm. The connector temperature was measured by a thermocouple placed on the sleeve. Since the MU ferrule diameter was only 1,25 mm, the sleeve temperature was almost the same as that of the ferrule; ferrule temperature is the most important factor determining the long-term reliability of optical connectors [14].

Larger increases in temperature are observed in DSF rather than in SMF due to higher power density. The result suggests that the temperature increase could be within 10 °C under practical conditions of loss and power. A commercial dry-type connector cleaner was used in every test for cleaning the endface of the connectors.

During repeated connection-disconnection of the connectors, neither damage nor fibre fuse was observed. The experiments in which a cleaner was used identified no problems in terms of fibre/connector damage and reliability. Without the cleaner, however, the experiment with the DSF connector indicated that fibre fuse could occur after repeated connection-disconnection of more than 200 times.

Such temperature increase, and accordingly the danger of fibre fuse, will be worse for non-zero dispersion shifted single-mode fibre (NZ-DSF) connectors than for SMF connectors but better than for DSF connectors, because the effective areas ~~are SMF > NZDSF > DSF~~ of SMFs is typically larger than that of NZ-DSFs, and the effective area of NZ-DSFs is larger than those of DSFs. Further quantitative studies are needed. Other types of physical contact (PC) connectors, like SC connectors (see IEC 61754-4 [15]), show similar temperature responses, because only their ferrule radii differ from MU type connectors.

In conclusion, it is shown that the thermal effects induced by connector and splice losses in high-power amplifiers could be acceptable under any practical conditions foreseeable at this moment. However, ~~special care should be taken~~ it is advisable to eliminate dust and contamination from the connector endfaces and splice points that could locally induce high temperature increases according to the power density absorbed.

**Table 2 – Measurement conditions**

| Parameter               | Conditions                 |
|-------------------------|----------------------------|
| Fibre                   | SMF, DSF                   |
| Connectors              | MU type                    |
| Ferrule                 | Zirconia                   |
| Connector/splice loss   | Imperfect alignment        |
| Wavelength              | Raman pump: 1 480 nm       |
| Power                   | 2 W                        |
| Temperature measurement | Thermocouple on the sleeve |

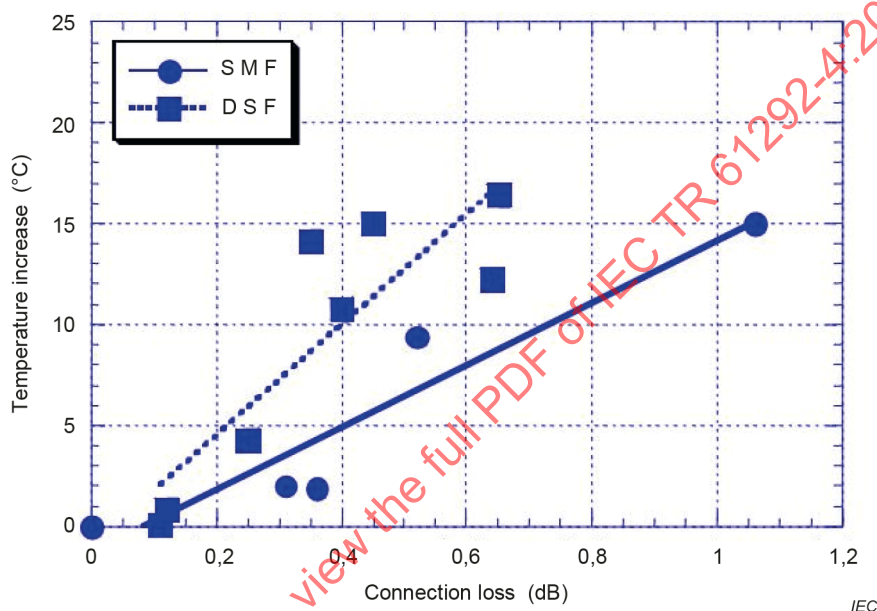

**Figure 2 – Connection loss versus temperature increase**

**4.4 Connector endface damage induced by dust/contamination**

The purpose of 4.4 is to show the increase in attenuation of the connector under test when the light power into the fibre is extremely high [16].

Figure 3 shows the scheme of the measurement set-up used in the test. The pump laser of a Raman amplifier is used with a maximum nominal power of 2 W, at a wavelength of 1 455 nm.

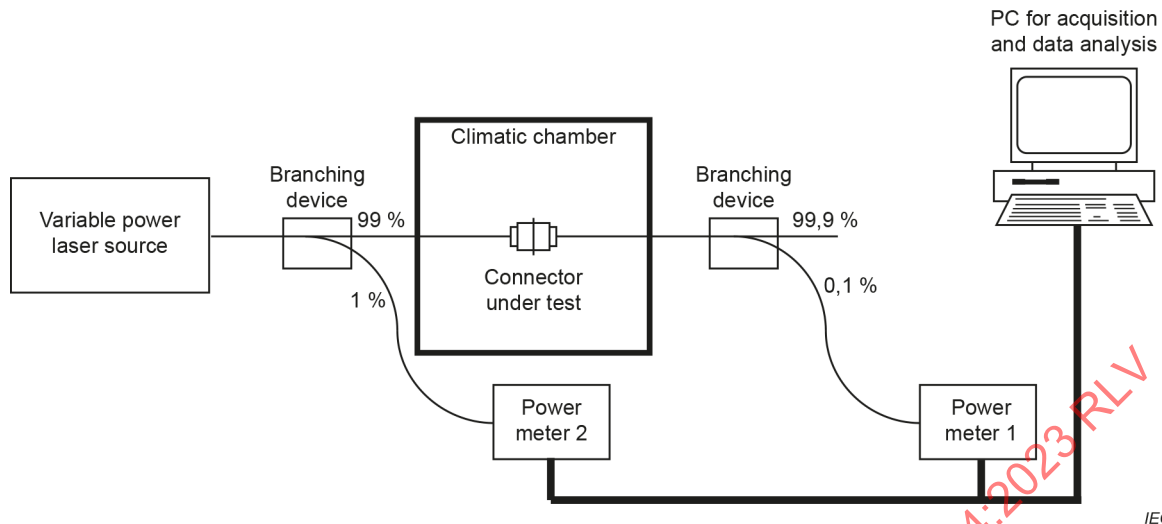

Figure 3 – Test set-up

The optical connectors used are SC-PC type with a perfectly clean surface and with skin grease (from the human operator), dust (from the floor of the lab), and metal filings (from a metallic sleeve) applied.

a) Test result on clean connectors

Two plugs without defects on the polished fibre surface were used. The laser power was increased in steps to 1,2 W after a thorough cleaning. The test was conducted at ambient temperature and in a chamber at 70 °C. During the entire test, the variation of the attenuation was less than 0,02 dB and the visual examination of the fibre surface at the microscope did not show any damage.

b) Test result on connectors contaminated with skin grease

A layer of grease was put down on two plugs without any defect, by simply touching the polished surface with the hands. When increasing the power from 100 mW to 1 200 mW at ambient temperature, the attenuation varied within a few hundredths of a dB. The visual inspection with a microscope after the test showed a cleaning effect, probably due to high temperature near the fibre. After the surface cleaning, no damage was observed.

c) Test result on connectors contaminated with dust

In this case, dust from the laboratory floor was put on the polished surface of the plugs. After the initial increase of the attenuation from a normalized value of 0 dB to 0,06 dB with 200 mW input power, the attenuation started to decrease with the increase in the power until -0,15 dB with 1,2 W input power. This effect of improvement in power transmission could be due to a cleaning action of the high temperature on the finest particles. Also, in this case, after the cleaning at the end of the test, the surfaces did not show any damage.

d) Test result on connectors contaminated with metal dust

In this test, metal dust obtained by filing a metallic sleeve of an adapter was put down on the plug surfaces. This condition simulates the presence of metallic particles produced by the friction of the ferule during the insertion into a metallic sleeve.

A first test was performed by heavily contaminating the surfaces, as Figure 4 shows. ~~This~~ The heavy contamination is ~~clear~~ evident from the initial attenuation value, which was 3 dB to 4 dB higher than the ones obtained for the other conditions.

During the test, already at 200 mW, the attenuation increased by about 0,3 dB. At the 400 mW step, the damage became evident as the attenuation increased to 1,1 dB (see Figure 5). As failure occurred, the test was stopped to visually inspect the surfaces.

Obvious signs of burning were observed on the core of both fibres that could not be eliminated by cleaning the surface. The visual inspection of polished surface through a microscope (Figure 6) shows fused metal ~~glued~~ embedded on the fibre cores. These ~~clots~~ contaminations are not removable by cleaning the surfaces.

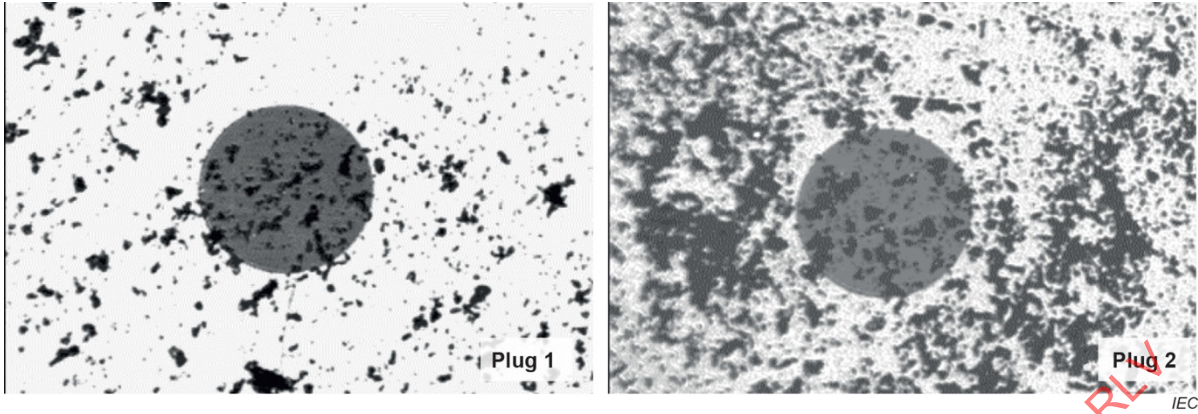

Figure 4 – Surface condition contaminated with metal filings, before the test

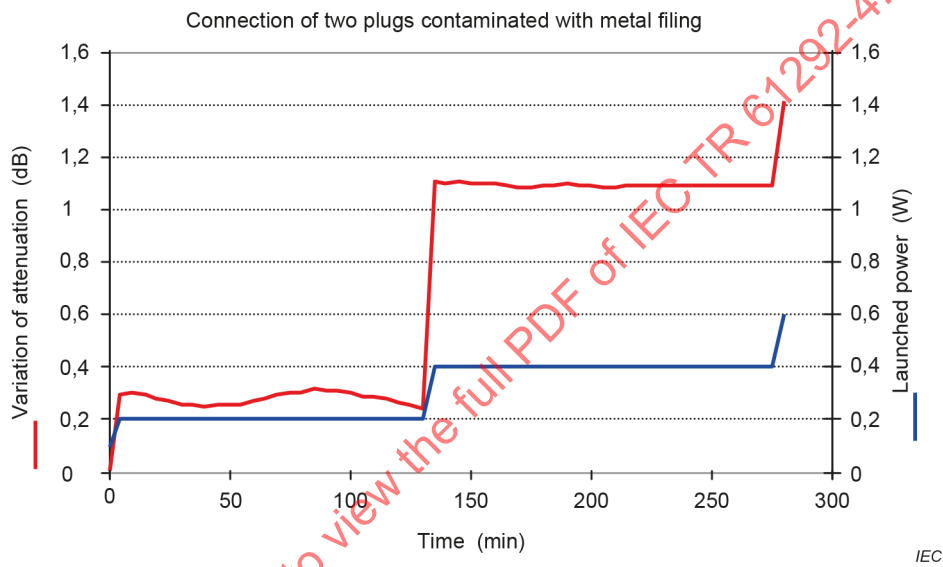

Figure 5 – Variation of power attenuation during test at several power input values for plugs contaminated with metal filings

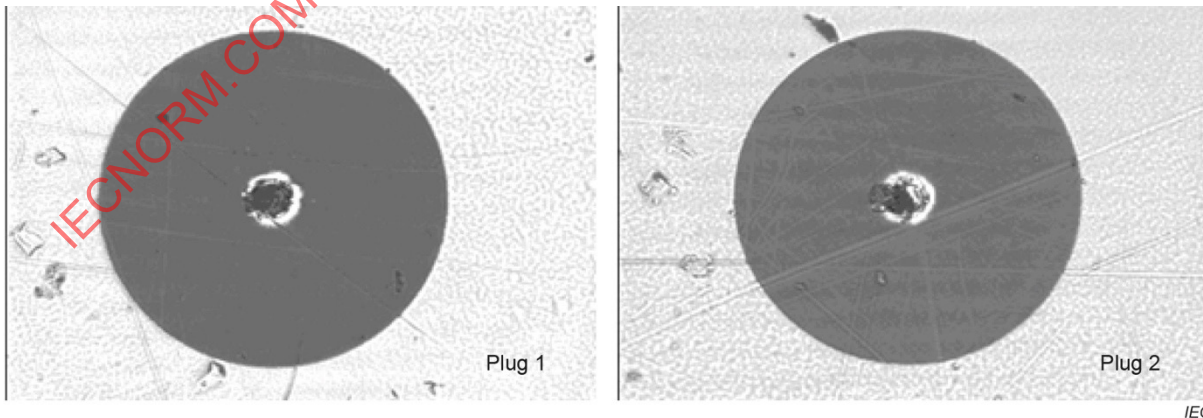

Figure 6 – Polishing surface condition contaminated with metal filing, after test

In conclusion, it was confirmed that there is no damage risk to the connectors due to high optical power under the conditions tested, if the connectors are correctly used and handled. In particular, it is ~~recommended never~~ not advisable to ever open connectors while high optical power is passing through them. However, a correct cleaning procedure and visual analysis of

the polished connector surface is fundamental for a good and reliable network, particularly when metallic sleeves are used.

#### 4.5 Fibre coat burn/melt induced by tight fibre bending

Subclause 4.5 provides some examples of the fibre coat burn/ or melt induced by tight fibre bending [8]. The fibre coatings used were

- a) UV curable resin: white, blue, green, and uncoloured, and
- b) nylon white.

The fibre used was single-mode (SMF).

By using a thermo viewer image of the bent fibre, the highest temperature at the surface of each fibre coating was measured. Figure 7 shows an image of the tightly bent fibre with an optical power of 3 W at 1 480 nm. Shown in Figure 8 is the temperature at the coating surface versus bending diameter for 3 W at 1 480 nm. The temperature of the nylon coat surface reached 150 °C or higher; the nylon coating melted or even burned. The nylon coat burned in the test after the fibre break at the point where the fibre coat melted.

By considering the test results together with the long-term reliability degradation of coated SMF, it is suggested that the coated fibre bend diameter ~~should~~ be kept at more than 20 mm and more than 30 mm for optical powers of 1 W and 3 W, respectively, under the conditions tested. Another test revealed that transparent UV resin was more durable than coloured UV resin against tight bending.

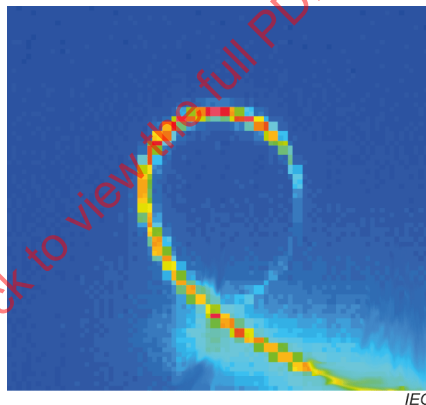
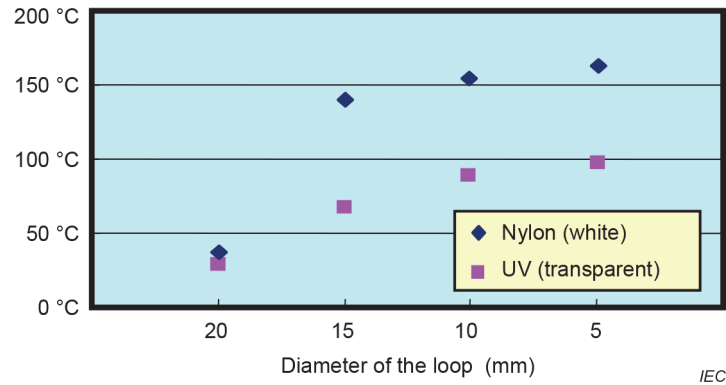

Figure 7 – Thermo viewer image of tightly bent SMF with optical power of 3 W at 1 480 nm



**Figure 8 – Temperature of the coating surface of SMFs against bending with optical power of 3 W at 1 480 nm**

#### 4.6 Summary of the fibre damage

In 4.2, it was found that fibre fuse, once it was initiated for any reason, propagated if the input signal power was higher than 1,4 W and 1,2 W for SMF and DSF, respectively, under the conditions tested. However, ~~care should be taken~~ it is not advisable to even momentarily push the fibre across a sharp edge that ~~may~~ could induce a tight bend and trigger fibre fuse even at a lower power than the above.

In 4.3, it was shown that the thermal effects induced by the connector and splice losses in high-power amplifiers could be acceptable under any practical conditions.

In 4.4, the connectors were tested with the input powers up to 1,2 W. It was found ~~that only case discovered~~ that the only case that caused permanent damage to the fibre core was when surfaces were contaminated with metal particles.

In 4.5, fibre coat burning induced by fibre tight bending was addressed. It is suggested that the bend diameter of coated fibre ~~should~~ be kept over 20 mm and 30 mm for optical powers of 1 W and 3 W, respectively, under the conditions tested.

Based on 4.2 to 4.5, it is concluded that power levels up to at least 1,2 W can be used without damaging OAs. The actual upper limit of the power is under study by considering, for example, the types of fibre and cleanliness of the fibre endfaces.

In addition, IEC TR 62627-01 [4] describes methods to prevent damage to the connector, and IEC TR 62547 [3] describes methods to measure the damage of fibre tight bending.

## 5 Maximum transmissible optical power to keep eyes and skin safe

### 5.1 Maximum transmissible exposure (MPE) on the surface of eye and skin

In IEC 60825-1:2014, MPE is defined as the "level of laser radiation to which, under normal circumstances, persons may be exposed without suffering adverse effects" [17]. The MPE values used by IEC have been specified in the ANSI-Z136 series [18] and are based on ~~animal non-human~~ experiments. IEC TR 60825-14:2004 gives more details on MPE [19].

IEC 60825-2:2004 includes the following ~~normative~~ text in which it is requested that optical fibre communication systems (OFCSs) be designed not to exceed the MPE, including the time period before an automatic power reduction (APR) system completes its function [20]:

"Where the OFCS uses an APR feature to meet the limits of a hazard level that is lower than that which would have to be assigned if no APR feature would be present, the irradiance or ~~radiation~~ radiant exposure during the maximum time to reach the lower hazard level [...] (not

greater than 1 s for unrestricted, 3 s for restricted or controlled locations) shall not exceed the irradiance or radiant exposure limits for either the eye or skin (equivalent to MPEs for the eye and skin), corresponding to the shut-down period of the APR. For unrestricted/restricted locations and controlled locations the measurement distances ~~is~~ are 100 mm and 250 mm, respectively, for this subclause [i.e., IEC 60825-2:2021, 4.7.4] only."

NOTE In the text described in IEC 60825-2, there is a sentence with a clause number, but in the above text, that number is deleted.

In IEC 60825-2 [20], the hazard levels of laser products, including OAs, are determined based on the classification rule of IEC 60825-1 [17]. In the existing standards, automatic laser shutdown (ALS) could have the same meaning as APR.

## 5.2 Maximum permissible optical power in the fibre for the safety of eye and skin

### 5.2.1 General

~~Informative Annex D of IEC 60825-2:2004 and IEC 60825-2:2004/AM2:2010 gives the following formula that calculates the maximum permissible optical power  $P$  in the fibre by using the maximum permissible exposure (MPE) to the eyes/skin after free space propagation.~~

$$P = \frac{\pi d^2 MPE}{4t} \frac{1}{1 - \exp \left[ -0,125 \left( \frac{\pi \omega_0 d}{\lambda NOHD} \right)^2 \right]} \quad (1)$$

where

~~$P$  is the total power in fibre, in W;~~

~~$MPE$  is the maximum permissible exposure,  $Jm^{-2}$ ;~~

~~$\omega_0$  is the mode field diameter (1/e<sup>2</sup> power density), in m;~~

~~$d$  is the limiting aperture diameter, in m;~~

~~$t$  is the shut down time, in s;~~

~~$NOHD$  is the nominal ocular hazard distance, in m;~~

~~$\lambda$  is the wavelength, in m.~~

~~Based on Formula (1), Table D.14 of IEC 60825-2:2004 and IEC 60285-2:2004/AMD2:2010 shows examples of power limits for optical fibre communication systems that have the APR to reduce the power to a lower hazard level. MPEs used in the calculation are shown in Tables 5, 6 and 7 of IEC 60825-14:2004.~~

~~Table 3 reiterates Table D.14 of IEC 60825-2:2004 and IEC 60285-2:2004/AMD2:2010. It shall be noted that the maximum permissible optical power in such OAs can be increased by reducing the power reduction time of the APR (the shut down time).~~

### 5.2.1 Power limit

Table 3 shows examples of power limits for unrestricted, restricted and controlled access (see 5.2.4) of OFCSs that employ APR to reduce the power to a lower hazard level, which is described with reference to IEC 60825-2:2021, Table D.3 [20]. It is worthwhile noting that the maximum permissible optical power in such OAs can be increased by reducing the power reduction time of the APR (the shut down time).

**Table 3 – Examples of power limits for optical fibre communication systems having automatic power reduction to reduce emissions to a lower hazard level**

| Wavelength     | MFD | Maximum power output unrestricted | Maximum power output restricted | Maximum power output controlled | Shutdown times | Measurement distance |
|----------------|-----|-----------------------------------|---------------------------------|---------------------------------|----------------|----------------------|
| nm             | µm  | mW                                | mW                              | mW                              | s              | m                    |
| 980            | 7   | 9,4                               | 9,4                             | N/A                             | 1              | 0,1                  |
| 980            | 7   | N/A                               | 7,2                             | N/A                             | 3              | 0,1                  |
| 980            | 7   | N/A                               | N/A                             | 39                              | 3              | 0,25                 |
| 1 310          | 11  | 78 2 587                          | 78 2 587                        | N/A                             | 1              | 0,1                  |
| 1 310          | 11  | N/A                               | 59 1 966                        | N/A                             | 3              | 0,1                  |
| 1 310          | 11  | N/A                               | N/A                             | 314 10 347                      | 3              | 0,25                 |
| 1 400 to 1 500 | 11  | 1 598                             | 1 598                           | N/A                             | 0,3            | 0,1                  |
| 1 400 to 1 500 | 11  | 650                               | 650                             | N/A                             | 1              | 0,1                  |
| 1 400 to 1 500 | 11  | N/A                               | 389                             | N/A                             | 2              | 0,1                  |
| 1 400 to 1 500 | 11  | N/A                               | 288                             | N/A                             | 3              | 0,1                  |
| 1 400 to 1 500 | 11  | N/A                               | N/A                             | 2 403                           | 2              | 0,25                 |
| 1 400 to 1 500 | 11  | N/A                               | N/A                             | 1 774                           | 3              | 0,25                 |
| 1 550          | 11  | 2 539                             | 2 539                           | N/A                             | 0,5            | 0,1                  |
| 1 550          | 11  | 1 273                             | 1 273                           | N/A                             | 1              | 0,1                  |
| 1 550          | 11  | N/A                               | 639                             | N/A                             | 2              | 0,1                  |
| 1 550          | 11  | N/A                               | 428                             | N/A                             | 3              | 0,1                  |
| 1 550          | 11  | N/A                               | N/A                             | 2 640                           | 3              | 0,25                 |

Source: IEC 60825-2:2021, Table D.3 [20].

NOTE 1 The fibre parameters used are the most conservative case. Listed figures for  $\lambda = 1\ 310\ \text{nm}$  to  $1\ 550\ \text{nm}$  are calculated for a fibre with  $11\ \mu\text{m}$  MFD and those for  $\lambda = 980\ \text{nm}$  are for  $7\ \mu\text{m}$  MFD. Many systems operating at  $1\ 550\ \text{nm}$  with erbium-doped fibre amplifiers (EDFAs) pumped by  $1\ 480\ \text{nm}$  or  $980\ \text{nm}$  lasers use transmission fibres with smaller MFDs. For example,  $1\ 550\ \text{nm}$  dispersion shifted fibre cables have upper limit MFD values of  $9,1\ \mu\text{m}$ . ~~In this case, the maximum power outputs for unrestricted and restricted areas at  $1\ 480\ \text{nm}$  and  $1\ 550\ \text{nm}$  are 1,44 times the values in Table D.14, and those for controlled areas at  $1\ 480\ \text{nm}$  and  $1\ 550\ \text{nm}$  are 1,46 times the values in same table.~~

NOTE 2 Times given in the table are examples; ~~shutdown at any shorter time than the maximum is permissible, and may permit the use of higher powers~~ The shutdown times shown include shorter times than the maximum. Shorter shutdown times enable the use of higher powers. (The maximum times are 1 s for unrestricted locations and 3 s for restricted and controlled locations, respectively).

NOTE 3 The high-power density in an optical fibre cable can cause fibre fuse, which leads to high temperature along the fibre cable.

For these power limits, it is assumed that the user does not employ any optical instrument or viewing optics within the beam. When optical instruments or viewing optics are not used, devices classified as 1M are considered safe under the conditions indicated in IEC 60825-1:2007 [17]. However, they ~~may~~ can be hazardous if the user employs optical instruments or viewing optics within the beam.

### 5.2.2 Need for APR

ITU-T Recommendation G.664:2012, Appendix II, suggests that APR is needed not only on the main optical signal sources but also on all pump-lasers employed [6]. It specifically states:

"[In particular,] distributed Raman amplification systems will need specific care to ensure optically safe working conditions, because high pump powers (power levels above +30 dBm are not uncommon) may be injected in optical fibre cables. Therefore, APR procedures [are required in order to] avoid hazards from laser radiation to human eye or skin and potential additional hazards such as temperature increase (or even fire) caused by local increased absorption due to connector pollution/damages [or very tight fibre bends].

[...]

In order to ensure that the power levels emitting from broken or open fibres connections are at safe levels, it is necessary to reduce the power not only on the main optical signal sources but also on all pump-lasers employed, in particular the backward pumping lasers."

### 5.2.3 Wavelengths

When determining the safe limit of the optical amplifier power set by the MPE limit ~~should~~, it is advisable to include the main optical signal power, the pump-laser powers, and the optical supervisory channel power, if used.

### 5.2.4 Locations

Table 4 shows location types within an optical fibre communication system and their typical installations. See IEC 60825-2 for more details [20].

**Table 4 – Location types within an optical fibre communication system and their typical installations**

| Location type       | Typical installation<br>(informative)   |
|---------------------|---|
| Unrestricted access | <del>Accessible by the public (e.g. domestic premises, premises open to the public</del><br>Domestic premises, services industries that are open to the general public (e.g. shops and hotels), public areas on trains, ships or other vehicles, open public areas such as parks, streets, etc., non-secured areas within business/industrial/commercial premises where members of the public are permitted to have access, such as some office environments  |
| Restricted access   | <del>Secured areas within business/commercial premises not open to the public (e.g. telephone PABX rooms, computer systems, etc.)</del><br>Secured areas within industrial premises not open to the public, secured areas within business/commercial premises not open to the public (for example telephone private automatic branch exchange (PABX) rooms, computer system rooms, etc.), general areas within switching centres, delimited areas not open to the public on trains, ships or other vehicles |
| Controlled access   | Cable ducts, street cabinets, dedicated and delimited areas of distribution centres, test rooms in cable ships  |

### 5.2.5 Nominal ocular hazard distance (NOHD)

In controlled locations, NOHD at which the level of exposure ~~should drop~~ drops to the MPE for the eye is 25 cm, because personnel ~~should~~ is expected to be trained to keep the 25 cm distance. Otherwise, the NOHD is 10 cm, because the minimum focal distance for the human eye is generally known to be 10 cm.

### 5.2.6 Power reduction times

Power reduction time is the maximum time span after the incident before the APR completes its task. ITU-T Recommendation G.664 suggests, as information, the power reduction times for OAs in multi-vender systems. For systems without line amplifiers, the APR time suggested is less than 800 ms, and that for OAs in systems with line amplifiers is less than 3 s, as described in ITU-T Recommendation G.664:2012, Appendix II [6]:

"After at least 500 ms of continuous presence of the LOS (loss of signal) defect, the actual shutdown command will be activated, which shall result in reduction of the optical output power at MPI-S [(single channel source main path interface reference point)] within 800 ms from the moment loss of optical signal occurs at MPI-R [(single channel receive main path interface reference point)].

[...]

In order to avoid exposure to hazardous optical power levels, all amplifiers (boosters and line amplifiers) shall have sufficiently short deactivation times to accommodate shutdown of all amplifiers between MPI-S and MPI-R within 3 s from the moment the actual connection interruption occurs.

NOTE 1 Depending on the actual operational power, the 3 s shutdown time (defined in the past) might not be fast enough. A check against IEC 60825-1 [...] is recommended."

Within the above limit, the maximum permissible optical power shown in Table 3 can be increased if the power reduction time for the APR can be shortened. Figure 9 shows the maximum permissible power in the fibre against APR power reduction times ~~that were derived by using Formula (1) in 5.2.1.~~

IECNORM.COM : Click to view the full PDF of IEC TR 61292-4:2023 RLV

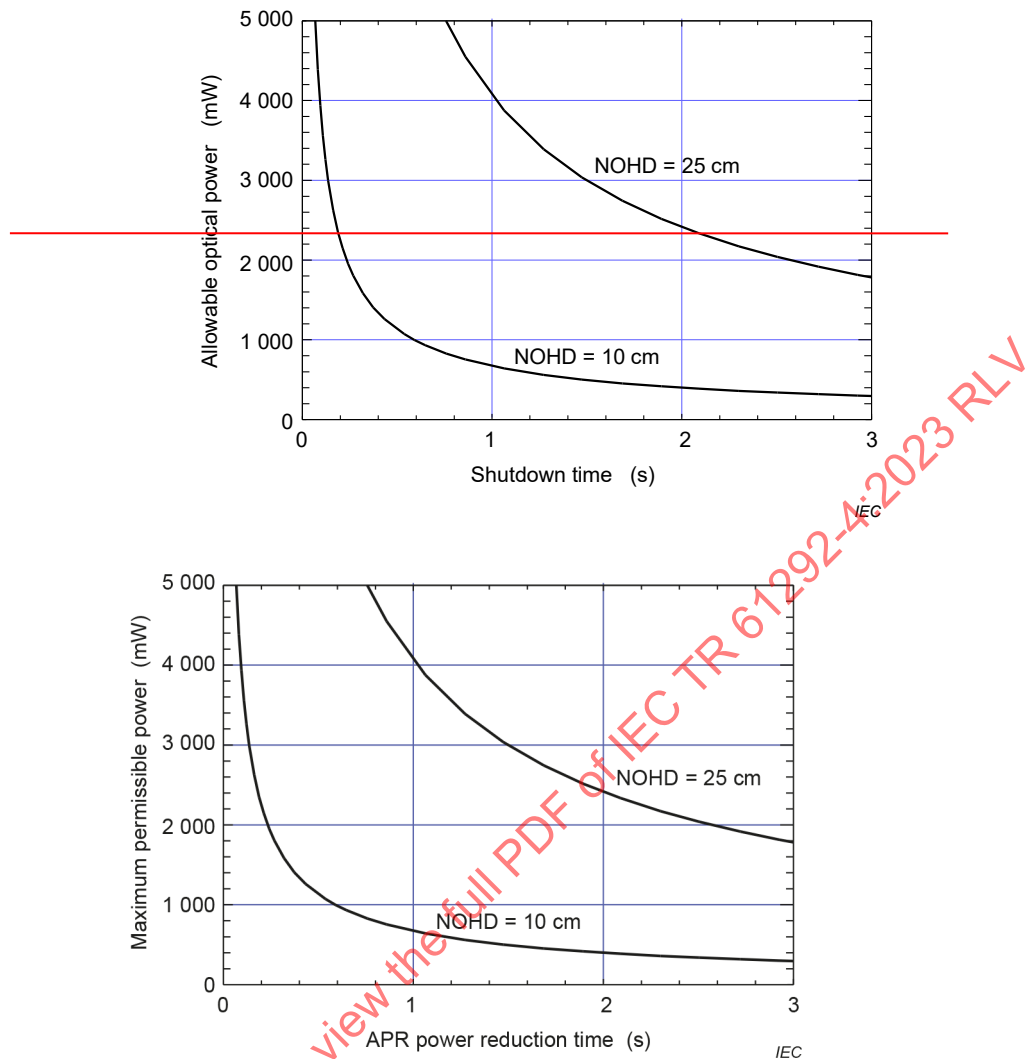

NOTE 1 In the restricted/controlled area, the OA classification is determined based on the optical power measured 3 s after the incident.

NOTE 2 Fibre mode field diameter = 11  $\mu\text{m}$ , wavelength = 1 480 nm.

**Figure 9 – Maximum permissible power in the fibre against APR power reduction time**

### 5.2.7 Medical aspects of the safety of eyes and skin in existing standards

Concerning the medical aspects of the safety of eyes and skin, the following information is found in IEC TR 60825-14 [19].

- The retinal hazard region is typically understood as 400 nm to 1 400 nm ~~(see 4.3.3 of IEC 60825-14:2004)~~.
- The pupil diameter used here is 7 mm assuming a dark room, although it is 4 mm to 5 mm in a regular room ~~(see 4.3.2 of IEC 60825-14:2004)~~.
- From 1 400 nm to 1 500 nm, for exposure time  $t = 1 \text{ ms}$  to 10 s, the MPE values are the same for cornea and skin, being given as  $5\,600 t^{0,25} \text{ Jm}^{-2}$  ~~(Table 5 of IEC 60825-14:2004)~~. However, the consequences of injury to the eyes are usually much more serious than equivalent injuries to the skin ~~(see 7.3.3.1 of IEC 60825-14:2004)~~.
- There is no "eye-safe" ~~waveband~~ wavelength band ~~(see 7.3.3.2 b) of IEC 60825-14:2004)~~.

Infrared light with a wavelength  $> 1\,400$  nm (or sometimes  $> 1\,300$  nm) normally does not penetrate into the eye but causes damage to the cornea. It is also understood that visible light (400 nm to 700 nm) and light  $\leq 1\,400$  nm penetrate and cause damage to the retina. It is also known that retina damage is normally incurable: retinal cells do not re-grow.

## 6 Maximum optical power permissible for optical amplifiers from the viewpoint of fibre damage as well as eye and skin safety

Based on 4.2 to 4.5, it was concluded in 4.6 that power levels up to at least 1,2 W can be used without damaging fibres under the conditions tested if the following conditions apply:

- the fibre bend diameter is more than 20 mm;
- the connectors are kept "clean".

Next, from the viewpoint of eyes and skin safety, it was understood from 5.2 that pump powers in the 1 480 nm range for distributed Raman amplifiers can go up to 1,77 W or 2,59 W depending on the fibre mode field diameter (see Table 3) for the pump APR time of 3 s, if the high intensity light could leak only within controlled locations. With APR times shorter than 3 s, higher power ~~is allowed~~ can be applied.

It can then be concluded that the maximum optical power permissible for the damage-free and safe use of optical amplifiers can go up to at least 1,2 W, within controlled locations under the conditions shown in this document and with the APR time shorter than 3 s. The actual upper limit of the power is under study by considering, for example, the types of fibre and cleanliness of the fibre endfaces.

However, where there is potential light leakage due to, for example, a fibre break, ~~any~~ it is important to take precautions so that a system operating with an optical power of 1,2 W ~~shall~~ does not exceed permitted hazard levels (see IEC 60825-2 [20]). APR can be used to limit optical power to a suitable level. Moreover, it ~~shall be~~ is noted that, although signal power in the 1 550 nm range is generally much less than Raman pump power, signal power cannot always be neglected for OA safety and damage.

## 7 Conclusion

It is concluded under the conditions tested and considered that the optical power permissible for the damage-free and safe use of optical amplifiers can go up to at least 1,2 W for controlled locations when APR times are shorter than 3 s.

Since the technologies are constantly evolving, it is requested that the reader refers to the latest edition of IEC 61292-4 as well as to the latest editions of the relevant documents cited in this document.

## Annex A (informative)

### General information for optical fibre fuse

#### A.1 Introductory remark

Optical power in optical fibre is being increased to achieve an efficient transmission network by increasing the optical signal channel number and by maintaining a suitable SNR at a high transmission speed by using a high-power optical fibre amplifier and Raman amplification. This has led to increased concern about the damage caused by the fibre fuse phenomenon. Once the phenomenon is initiated, a bubble train forms in the fibre core after the fibre fuse, and it propagates towards the high optical power source and continues until the optical power in the core falls below the threshold fibre fuse power. Optical signals cannot be transmitted through fibre damaged in this way. There have been several studies regarding the generation mechanisms, the bubble formation mechanism and the emission properties from the plasma discharge that occurs when bubbles are formed. Recently, several prevention and termination methods for the fibre fuse have been proposed.

Annex A gives a general description of the generating mechanism and characteristics of fibre fuse and prevention and termination for the fibre fuse for a greater understanding about optical fibre fuses.

Annex A is based on Technical Paper TP08/AM-2010 [21].

#### A.2 Generating mechanism

The fibre fuse phenomenon was first observed in 1987 by Kashyap and Blow [7]. If this phenomenon was initiated in the fibre, an intense blue-white flash occurred and ran along the fibre core toward the light source at a relatively low velocity in the order of 1 m/s. Periodic and/or non-periodic voids were left after the blue-white flash passed through the core (see Figure A.1). This phenomenon results in catastrophic destruction of the optical fibre waveguide.

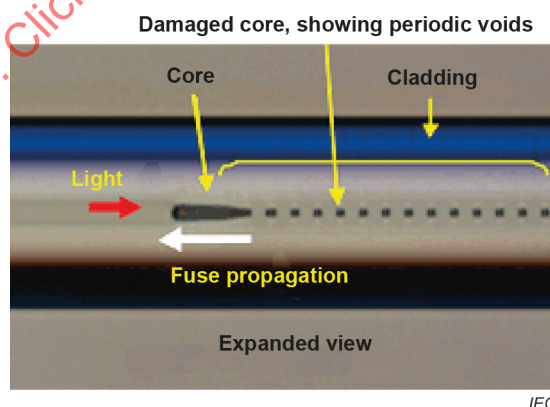

**Figure A.1 – Front part of the fibre fuse damage generated in the optical fibre**

In the experiments, the fibre fuse can be initiated by contacting the fibre output end with absorbing materials, heating the fibre by arc discharge, formation of bends and knots, and heating the fibre end with a flame or the heating furnace. The local heating of the fibre core due to large high-temperature light absorption is closely related to the generation of the fibre fuse phenomenon.

Several hypotheses have been put forward to explain the fibre fuse phenomenon. Typical hypotheses are shown as follows.

- a) Self-propelled self-focusing model [7]: It is considered that thermally generated third-order nonlinearity is produced by avalanche ionization in this model. The heating process increases the number of free electrons in the core through collisions and increases the local third-order nonlinearity. The increase in the nonlinearity causes self-focusing and collapse of the laser beam, resulting in the fibre fuse.
- b) Solitary thermal shock wave model [22]: In this model, a solitary thermal shock wave is responsible for the fibre fuse. The periodic damage track left after the passage of the shock wave arises through mode focusing in the thermal lens created by the wave.
- c) Exothermic chemical reaction model [23]: It is proposed in this model that the high temperature in the fibre fuse occurs by an exothermal chemical reaction of Ge-related defect formation with no light absorption.
- d) Radiative-collision reactions model [24]: In this model, the fibre fuse occurs by the radiative-collision reactions between SiO molecules and neighbouring non-bridge O atoms in the fibre core with large light absorption coefficients.
- e) SiO absorption model [25]: In this model, the fibre fuse occurs by the thermal production of SiO molecules with large light absorption coefficients at high temperatures.

Among these models, the avalanche ionization of the silica glass described in a) cannot be realized by using the conventional CW laser (0,1 W to 10 W output power) for the fibre fuse experiments. The thermal lens formation described in b) needs the large light absorption coefficient of  $540 \text{ cm}^{-1}$  to obtain a large temperature gradient in the core. However, the origin of the large absorption coefficient is not at all clear in [22]. Item c) in the above list cannot explain the generation of the fibre fuse observed in non-Ge-doped optical fibers. The radiative-collision reaction described in d) is not popular for US and European researchers.

On the other hand, e) is based on the well-known thermochemical reaction of  $\text{SiO}_2$ , and it can be applicable to many types of optical fibres. The fibre fuse parameters estimated by using e) are in fair agreement with the experimentally determined values.

The SiO absorption model is shown in Figure A.2. The  $\alpha$  (unit:  $\text{m}^{-1}$ ) exhibits the absorption coefficient of SiO (at the wavelength of 1 064 nm) per unit length of 1 m. The fibre fuse generation processes due to this model are as follows.

- 1) When the optical fibre is heated up to high temperatures of  $> 2\,000 \text{ K}$ , a lot of SiO molecules are produced by the thermal decomposition of  $\text{SiO}_2$  glass, which is the main component of the optical fibre.
- 2) SiO exhibits a large light absorption coefficient at high temperatures of  $> 2\,000 \text{ K}$ . So, heating of the optical fibre is enhanced by increasing the optical absorption of the SiO.
- 3) The heat in the core, produced by the optical absorption of the SiO, diffuses into the low-temperature parts placed outside the core.
- 4) When the heat produced in the core overcomes the heat consumed by diffusion, the core temperature is reached at  $10\,000 \text{ K}$  or higher, where the SiO is thermally decomposed into the neutral atoms or charged ions and is in the plasma state.
- 5) The plasma state occurred in the core is continuously maintained by absorbing the laser power supplied by the light source and is propagated along the fibre toward the source.

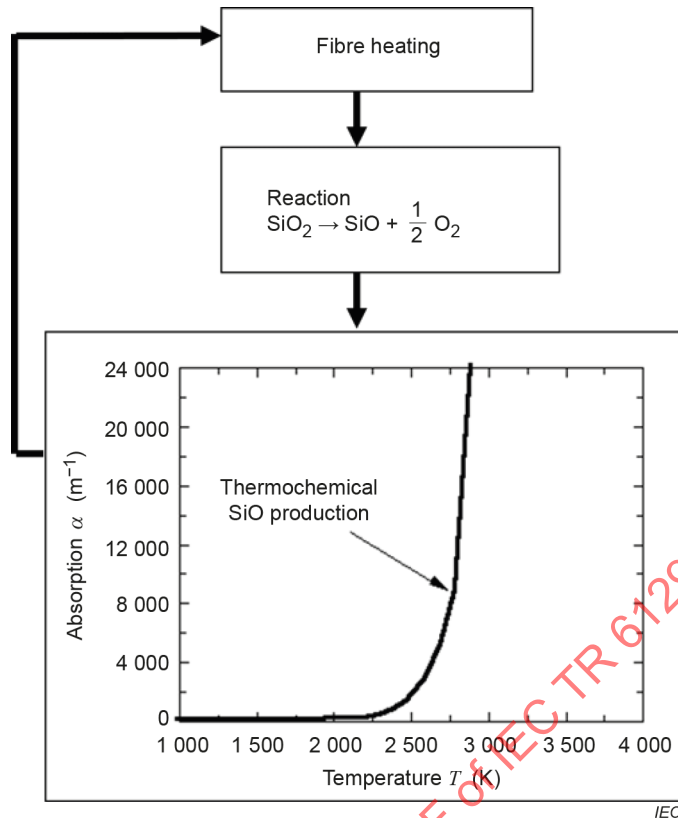

**Figure A.2 – SiO absorption model**

Figure A.3 exhibits the calculated fibre fuse propagation behaviour simulated with the SiO absorption model. Value  $z$  is the axis along the fibre length and of the laser-light propagation. Laser light propagates toward + direction of the  $z$  axis.  $r/r_f$  is the normalized radial distance  $r$  divided by the outer radius  $r_f$  ( $= 62.5 \mu\text{m}$ ) of the optical fibre, and  $r/r_f = 0$  is the location of the core centre. As the initial condition of Figure 3 at the time  $t = 0$  s, it was assumed that the small core region (length:  $500 \mu\text{m}$ ) at  $z = 0$  was heated at  $2\,500$  K. When the  $2$  W laser light (at the wavelength  $1\,064$  nm) was incident into the fibre core, the temperature ( $T$ ) distributions in the optical fibre after  $1$  ms ( $t = 1$  ms),  $22$  ms ( $t = 22$  ms), and  $43$  ms ( $t = 43$  ms) were as shown in Figure 3. As shown in Figure A.3, a sharp thermal peak with high temperature of  $> 50\,000$  K occurs after  $1$  ms at the small core region at  $z = 0$ , which was pre-heated at  $2\,500$  K and  $t = 0$  s. This peak is propagated along the core centre toward – direction of the  $z$  axis with the velocity of about  $0.4$  m/s. This fibre fuse velocity estimated with the SiO absorption model agrees very closely with the experimentally determined one [26], [27]. In addition, the propagation behaviour of the thermal peak is also explained by the propagation of the heat dissipative soliton [28].

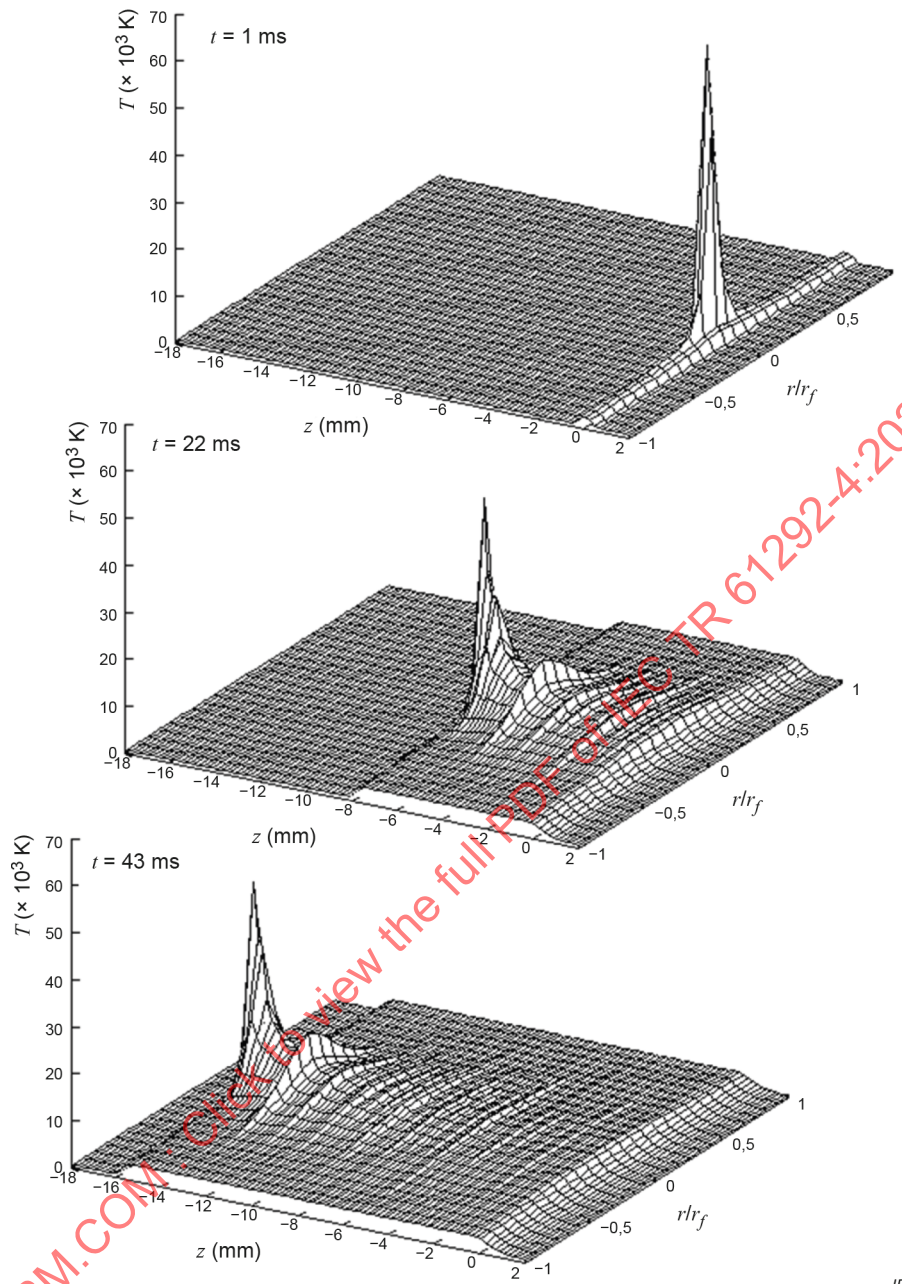

Figure A.3 – Calculated fibre fuse propagation behaviour simulated with the SiO absorption model

### A.3 Void formation mechanism

In order to investigate the void formation mechanism, one would need to observe the molten glass surrounding a fibre fuse directly, but this is hardly possible due to its strong light emission, i.e., black-body radiation more than several thousand K [29]. Alternatively, a mechanism has been proposed on the basis of the observation of the voids left after quenching a fibre fuse. Figure A.4 shows a set of fused damage micrographs that suggests a mechanism of periodic void formation [30]. These are the front part of void trains obtained by switching off the 9,0 W pump laser (wavelength: 1 480 nm) after a fibre fuse was generated in a single-mode ~~optical~~ fibre and was moving through a bare fibre segment. The reason of terminating the fuse at a jacket-free segment is to maximize the quenching rate of the molten glass by eliminating a re-absorption of backscattered visible radiation at the pigments in the jacket. They are sorted in order of increasing the distance between the top of the first large void in the left and the regular voids in the right. This sorted sequence seems to show frozen structures during a single void formation process for 18,7  $\mu\text{s}$  as described below.

- A bridge appears at the tail of the top long void – see Figure A.4, photographs number (1) and (2).
- The pinched-off void is compressed by the pressure of the plasma – see Figure A.4, photographs (3) to (6).
- To form a bullet-like shape – see Figure A.4, photographs (1) and (2).

The origin of this bridge formation is proposed to be Rayleigh instability [27] or electrostatic repulsion induced on the liquid-plasma interface [31].

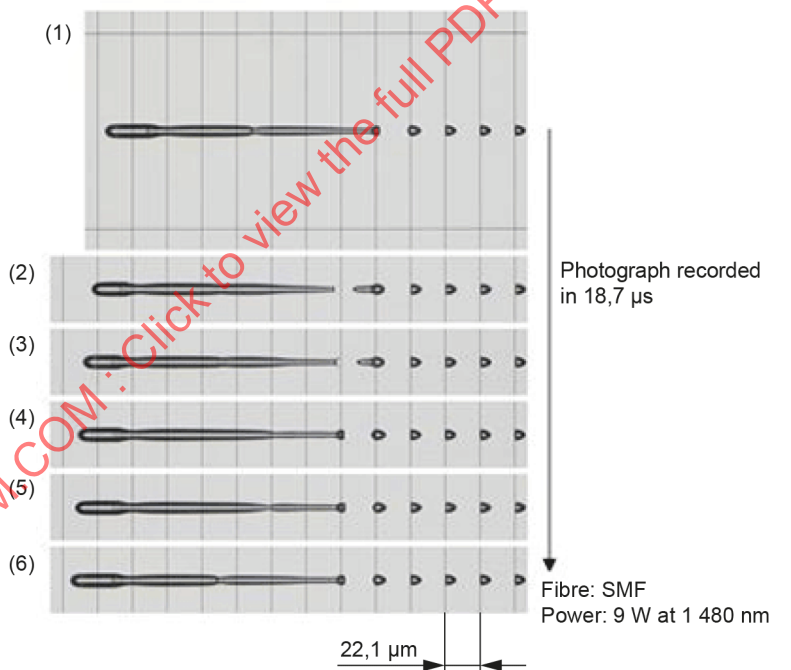

**Figure A.4 – Series of optical micrographs showing damage generated by 9,0 W 1 480 nm laser light suggesting a mechanism of periodic void formation**

### A.4 Propagation characteristic of a fibre fuse

Clause A.4 describes two basic characteristics: plasma propagation and periodicity of the voids in optical fibres.

Figure A.5 shows some images of fibre fuse ignition taken with an ultrahigh-speed camera (Figure A.5 a) and Figure A.5 b)) and an optical micrograph of the damaged fibre (Figure A.5 c)).

The fuse was initiated by the heat from light absorptive powder pressed on the output endface of a single-mode ~~optical~~ fibre delivering 9 W of light (1 480 nm). After a preliminary process, a stable running plasma appeared at the inside from the fibre end (approximately 300 μm in this case) leaving a periodic void train. Its speed was found to be constant at the resolution of microseconds [32].

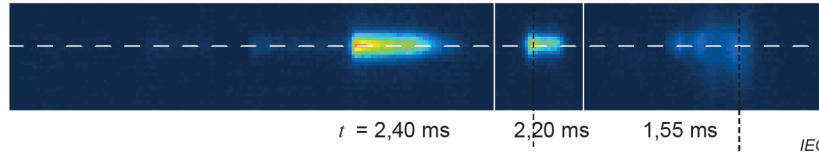

a) Photographs of visible light emission around the fibre fuse ignition in which original grayscale images are converted to colour-scale ones

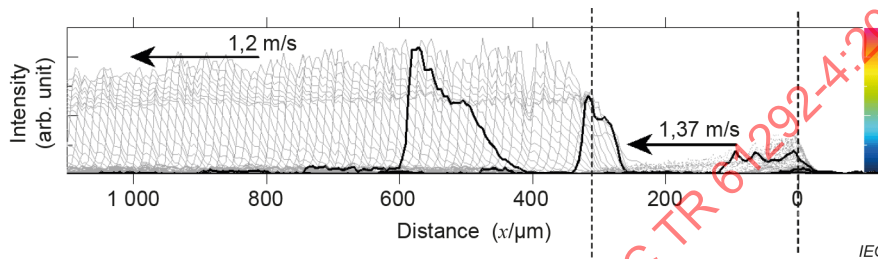

b) Intensity profiles along the dashed lines on the photographs taken every 10 ms

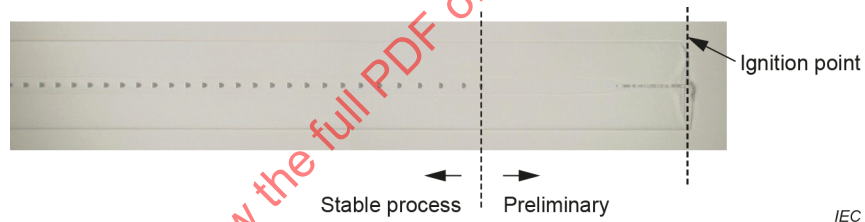

c) Optical micrograph of a damaged fibre

**Figure A.5 – Images of fibre fuse ignition taken with an ultra-high-speed camera and an optical micrograph of the damaged fibre**

Figure A.6 shows the relationship between the power density supplied to the fibre fuse and the propagation velocity at the wavelengths of 1 064 nm and 1 480 nm [25]. The open and closed circles are the experimental results [26], [27], [33]. The velocity of the fibre fuse increases with increasing the power density, and exhibits the values of 0,2 m/s to 1,2 m/s. The solid lines are the calculation results estimated with the SiO absorption model. The step-index single-mode ~~optical~~ fibre was assumed in the calculation. This fibre-fuse velocity estimated with the SiO absorption model agrees very closely with the experimentally determined ones.

In addition, Figure A.7 shows various void train patterns that were obtained by changing the pump laser power (1 480 nm) [30]. Under some conditions, the periodicity was lost. In other cases, the void interval increases with the laser intensity. When the laser power is reduced below 1,2 W, the fibre fuse cannot propagate stably and diminish spontaneously.

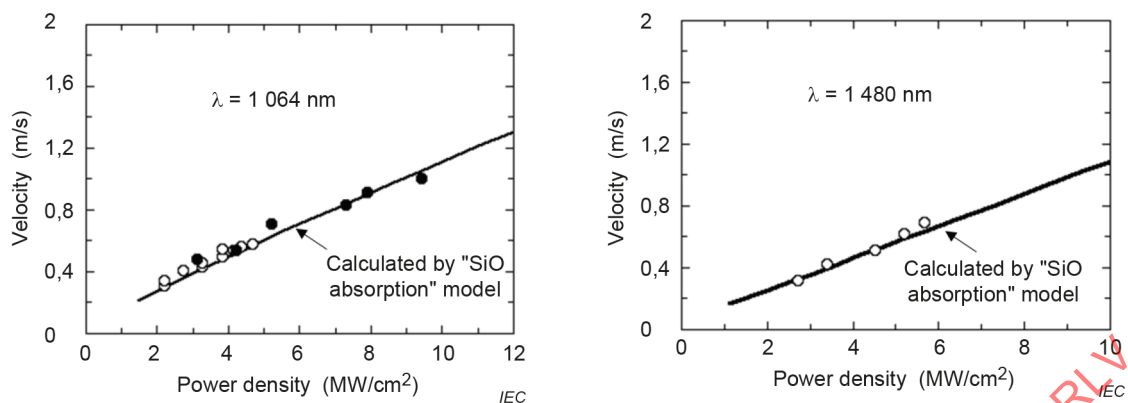

a) Propagation velocity at 1 064 nm wavelength      b) Propagation velocity at 1 480 nm wavelength

**Figure A.6 – Power density dependence of the fibre-fuse propagation velocity**

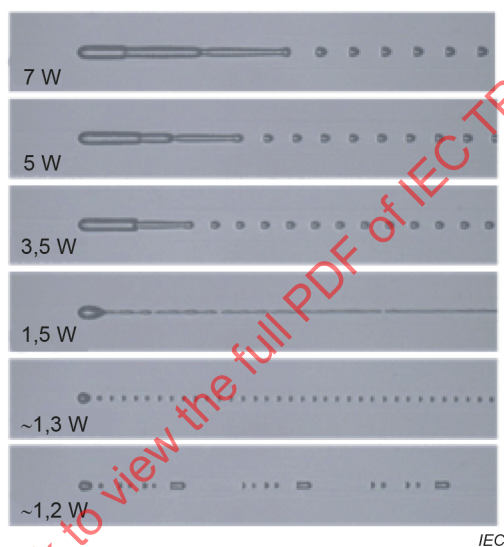

**Figure A.7 – Optical micrographs showing front part of the fibre fuse damage generated in SMF-28 fibres with various laser intensities (1 480 nm)**

## A.5 Prevention and termination

### A.5.1 General

If an optical fibre fuse is generated, optical signal transmission becomes impossible from the resulting damage. A prevention method that prevents the optical fibre fuse from being generated, and a termination method to prevent damage from propagating when it is generated, are both required for achieving practical optical fibre transmission systems. The prevention methods and termination methods which have been reported so far are introduced in A.5.2 and A.5.3.

### A.5.2 Prevention methods

In order to prevent fibre fuse, the countermeasure against contamination of an optical fibre connector endface, which is one of the main generating factors of the fibre fuse, is important. IEC TR 62627-01 describes this countermeasure [4]. Furthermore, literature relating to an optical fuse and optical limiting devices for suppressing light intensity in an optical fibre within light intensity for an optical fibre fuse to generate or propagate exist [34].

**A.5.3 Termination methods**

**A.5.3.1 General**

In order to terminate the fibre fuse, two methods currently exist:

- a) the passive method which prevents an optical fibre fuse by increasing the fibre fuse propagation threshold value above which a fibre fuse propagates by expanding the mode field diameter of the optical fibre;
- b) the active method which halts or reduces the output of the light source by detecting a characteristic return light observed when the optical fibre fuse is generated.

**A.5.3.2 Passive termination methods**

The principle of the passive method is shown in Figure A.8 a). The fuse propagation threshold power increases in proportion to the mode field diameter (MFD) of the optical fibre [35]. So it is possible to increase the fuse propagation threshold power by adopting a taper structure [36] or a TEC (thermally-diffused expanded core) structure [37] as the core of the optical fibre, and a fibre fuse can be discontinued in the section where the MFD was expanded. Figure A.8 b) shows a photograph of the fibre fuse terminator using a TEC structure [37]. Although the MFD of the section connected to the transmission fibre is the same as the usual optical fibre, the MFD of the fibre core of the middle section of a terminator is expanded. By expanding the MFD of a fibre core to 20 μm to 30 μm, it is realizable that the optical fibre fuse generated by a strong laser light (wavelength of 1 480 nm) of 2 W can be discontinued in the TEC section. In addition, it is reported that a hole-assisted structure is also effective in increasing the fuse propagation threshold power [38]-[41]. Figure A.9 shows a photograph in which the fibre fuse propagated on the left (from the right) is discontinued in a hole-assisted fibre [38]. It is considered that the fibre fuse termination by hole-assisted structure is for not reaching a temperature required in order to propagate the fibre fuse, when the hole interval of a hole-assisted fibre is narrow and the high temperature area is limited by the heat insulation effect by the hole layer, and the quantity of SiO which is a source of heat absorption lacks [39]. However, the more detailed study about the termination mechanism by the hole-assisted structure, is required. In addition, it was proposed that inserting a short segment of a hollow optical fibre in a normal single-mode optical fibre line was effective.

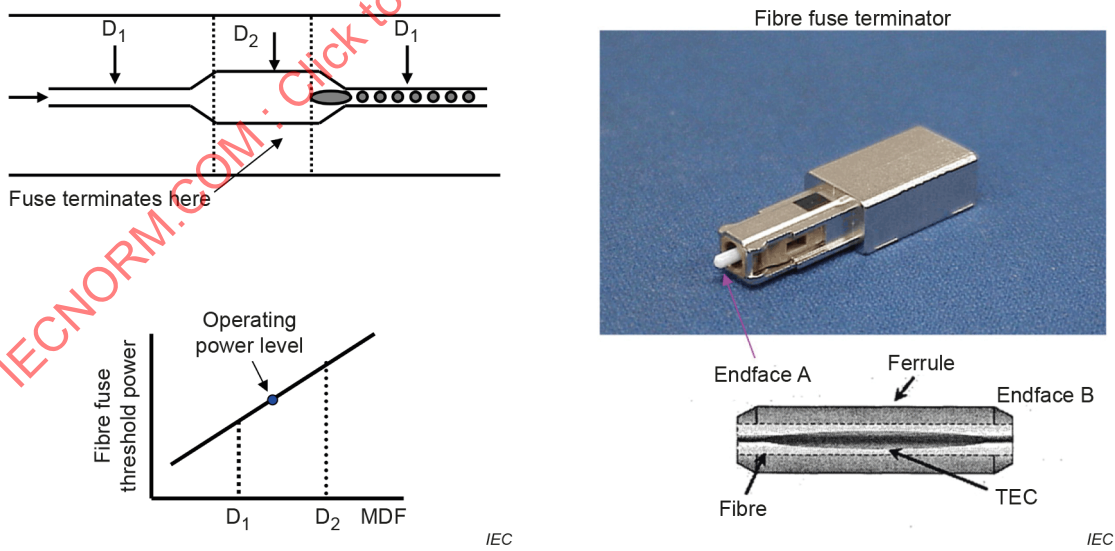

a) Principle of the optical fibre fuse passive termination method

b) Photograph of the fibre fuse terminator which adopted TEC structure

**Figure A.8 – Principle of the optical fibre fuse passive termination method and photograph of a fibre fuse terminator using a TEC structure**

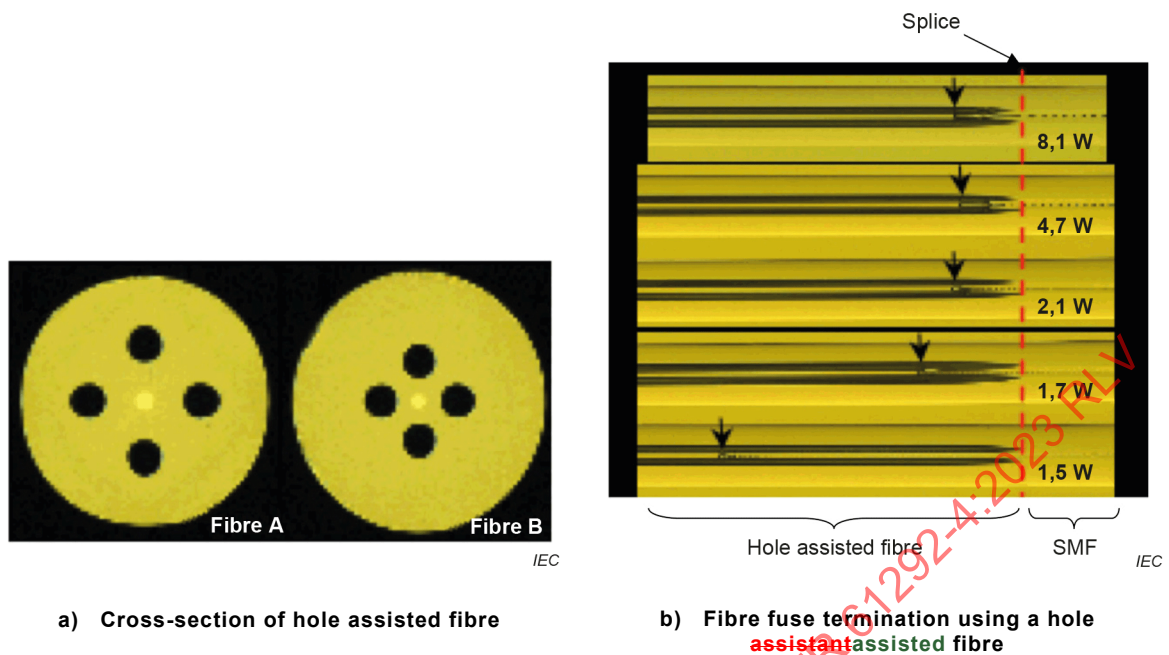

**Figure A.9 – Photograph of hole-assisted fibre and fibre fuse termination using a hole-assisted fibre**

### A.5.3.3 Active termination methods

By using the active method, fibre fuse generation is detected and the light of the high output light source which has caused the fibre fuse is halted [11]. Figure A.10 shows the scheme of this method. In this scheme, fibre fuse generation is apprehended, by detecting back reflected optical light from the void formation section using the photodiode, and the output signal from the photodiode is passing through a DC filter and an electrical power sensor which can distinguish the generating of a fibre fuse. When such a generation has been perceived, a control signal is sent from an electrical power sensor to a light source, and the fibre fuse is then interrupted by halting the output of light source which caused the fibre fuse. Figure A.11 shows the electrical spectrum (Figure A.11 a)) measured through the photodiode, and the electrical output signal (Figure A.11 b)) from the electrical power sensor which assesses generation of an optical fibre fuse. The optical power of 2,75 W is launched into the conventional optical fibre. The propagation velocity of the fibre fuse is 0,45 m/s. When the fibre fuse is generated, the electrical spectral intensity increases by about 40 dB to 50 dB over the wide spectral region. In addition, two signature spectrum components which correspond to the interval of the void formed with the fibre fuse ( $f_c$  interval, 31 kHz in this example) and Doppler shift frequency  $f_D$  (at 876,6 kHz in this example) are observed in the electrical spectrum. The  $f_c$  and  $f_D$  are described as follows:

$$f_c = v/p$$

$$f_D = 2nv/\lambda \tag{A.1}$$

where

- $p$  is the void interval formed with the fibre fuse (14,5  $\mu\text{m}$  in this example);
- $n$  is the refractive index of the fibre core;
- $v$  is the void velocity;
- $\lambda$  is the wavelength of optical light which generate the fibre fuse, respectively.

Figure A.11 shows the transformation of electrical signal by optical fibre fuse. The response time of this active method is around a few milliseconds, as shown in Figure A.11 b). It is possible to minimize the damage of the fibre fuse.

In addition, another method of fuse detection was proposed with a FBG temperature sensor thermally attached to the optical line.

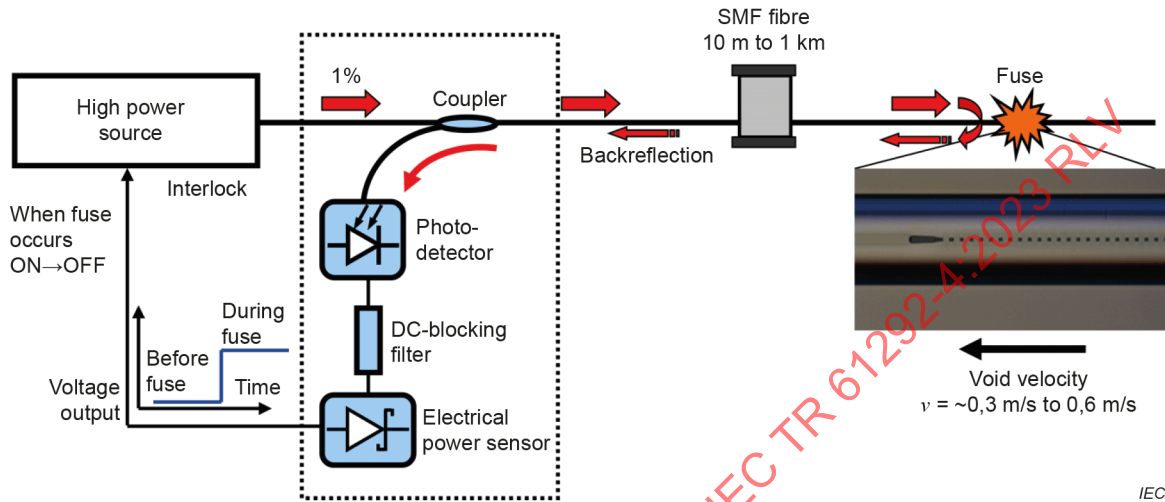
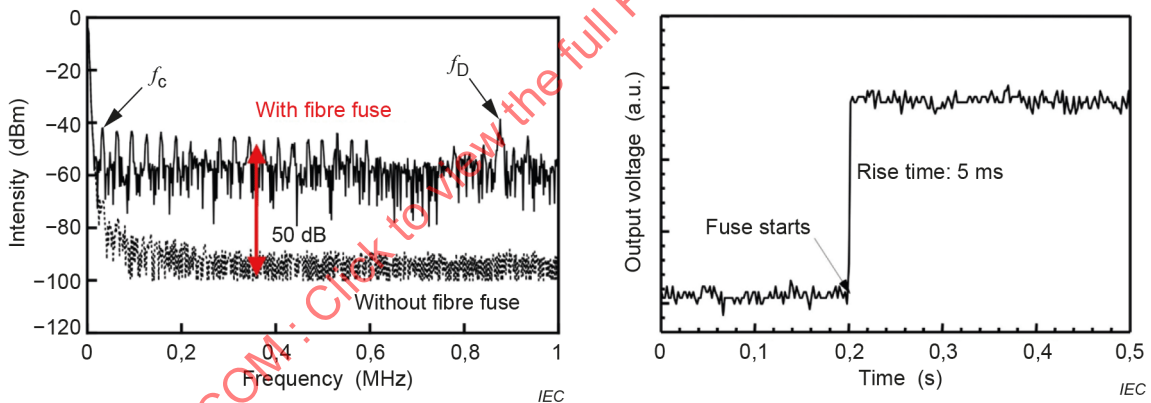

Figure A.10 – Example of fibre fuse active termination scheme



- a) **Generating electric spectrum outputted from the photodiode** Electrical spectrum of the photodiode output
- b) **Generating electric output signal from the electric power sensor** Electrical output signal from electrical power sensor

Figure A.11 – Transformation of electrical signal by optical fibre fuse

### A.6 Additional safety information

It has been reported that, when strong light is incident on an optical fibre in which void train are formed by the optical fibre fuse, the scattered light by the void train heats the optical fibre coating and finally burns it [42]. There is also a report on the safety of light scattered from the void train [43].

## A.7 Conclusion

General information concerning an optical fibre fuse, the generating mechanism, general characteristics and prevention methods as well as termination methods have been outlined. The optical fibre fuse is an important phenomenon from the viewpoint of the reliability of optical fibre communications systems and their safety operation.

IECNORM.COM : Click to view the full PDF of IEC TR 61292-4:2023 RLV

## Bibliography

- [1] IEC TR 61292-8, *Optical amplifiers – Part 8: High-power amplifiers*
- [2] IEC TR 61292-6, *Optical amplifiers – Part 6: Distributed Raman amplification*
- [3] IEC TR 62547, *Guidelines for the measurement of high-power damage sensitivity of single-mode fibre to bends – Guidance for interpretation of results*
- [4] IEC TR 62627-01, *Fibre optic interconnecting devices and passive components – Part 01: Fibre optic connector cleaning methods*
- [5] IEC TR 60825-17, *Safety of laser products – Part 17: Safety aspects for use of passive optical components and optical cables in high power optical fibre communication systems*
- [6] ITU-T Recommendation G.664:2012, *Optical safety procedures and requirements for optical transmission systems*
- [7] KASHYAP, R., et al., *Observation of catastrophic self-propelled self-focusing in optical fibers*, Electron. Lett., vol. 24, no. 1, pp. 47-49, 1988
- [8] SEO, K., et al., *Examination of Threshold Powers for High-power Problems in Optical Fibre*, International Laser Safety Conference, Jacksonville, USA, 2003
- [9] TODOROKI, S., *Origin of periodic void formation during fiber fuse*, Optics Express, vol. 13, no. 17, pp. 6381-6389, 2005
- [10] ABEDIN, K.S., et al., *Remote detection of fiber fuse propagating in optical fibers*, Proceedings of Optical Fiber Communication/National Fiber Optic Engineers Conference OThD5, 2009.
- [11] ABEDIN, K.S., et al., *Remote sensing of fiber fuse propagation using RF detection*, The Technical Report of The Proceedings of The Institute of Electronics, Information and Communication Engineers, OPE, Optoelectronics, vol. 109, no. 159, pp. 43-46, 2009. (In Japanese)
- [12] YANAGI, S., et al., *Characteristics of fibre-optic connector at high-power optical incidence*, Electron. Lett., Vol.38, No.17, 2002.
- [13] IEC 61754-6, *Fibre optic interconnecting devices and passive components – Fibre optic connector interfaces – Part 6: Type MU connector family*
- [14] SHINTAKU, T., et al., *Connection mechanism of physical contact optical fibre connectors with spherical convex polished ends*, Appl. Opt., 30, pp.5260-5265, 1991
- [15] IEC 61754-4, *Fibre optic interconnecting devices and passive components – Fibre optic connector interfaces – Part 4: Type SC connector family*
- [16] *Evaluation of the optical connector behaviour when high power is used*. Submitted by Telecom Italia Lab. to ITU-TSG6 Q7 as D.34 Kessel-Lo, 23-27 September 2002
- [17] IEC 60825-1, *Safety of laser products – Part 1: Equipment classification and requirements*
- [18] ANSI-Z136 (all parts), *Safe use of lasers*

- [19] IEC TR 60825-14, *Safety of laser products – Part 14: A user's guide*
- [20] IEC 60825-2:2021, *Safety of laser products – Part 2: Safety of optical fibre communication systems (OFCSS)*
- [21] Technical Paper TP08/AM-2010, *General Information for Optical Fibre Fuse*, Optoelectronic Industry and Technology Development Association (OITDA)
- [22] HAND, D.P., et al., *Solitary thermal shockwaves and optical damage in optical fibers: the fiber fuse*, Opt. Lett., vol. 13, no. 9, pp. 767-769, 1988
- [23] DRISCOLL, T.J., et al., *Explaining the optical fuse*, Opt. Lett., vol. 16, pp. 1046-1048, July 1991
- [24] YAKOVLENKO, S.I., *On reasons for strong absorption of light in an optical fibre at high temperature*, IEEE J. of Quantum Electronics, vol. 34, no. 9, pp. 787-789, 2004
- [25] SHUTO, Y., et al., *Fiber fuse phenomenon in step-index single-mode optical fibers*, IEEE J. of Quantum Electronics, vol. 40, no. 8, pp. 1113-1121, 2004
- [26] HAND, D.P., et al., *Soliton-like thermal shock-waves in optical fibers: origin of periodic damage tracks*, Proceedings of the 14th European Conference on Optical Communication, pp. 111-114., 1988
- [27] ATKINS, R.M., et al., *Track of a fiber fuse: a Rayleigh instability in optical waveguides*, Opt. Lett., vol. 28, no. 12, pp. 974-976, 2003
- [28] AKHMEDIEV, N., et al., *Heat dissipative solitons in optical fibers*, Physics Letters A, vol. 372, no. 9, pp. 1531-1534, 2008
- [29] DIANOV, E.M., et al., *High-speed photography, spectra, and temperature of optical discharge in silica-based fibers*, IEEE Photon. Technol. Lett., vol. 18, no. 6, pp. 752-754, 2006
- [30] TODOROKI, S., *Origin of periodic void formation during fiber fuse*, Optics Express, vol. 13, no. 17, pp. 6381-6389, 2005
- [31] YAKOVLENKO, S.I., *Mechanism for the void formation in the bright spot of a fiber fuse*, Laser Physics, vol. 16, no. 3, pp. 474-476, 2006.
- [32] TODOROKI, S., *Transient propagation mode of fiber fuse leaving no voids*, Optics Express, vol. 13, no. 23, pp. 9248-9256, 2005
- [33] KASHYAP, R., *Self-propelled self-focusing damage in optical fibres*, Lasers '87; Proc. the Tenth Int. Conf. Lasers and Applications, McLean, VA, STS Press, pp. 859-866, 1988
- [34] CHOUDHURY, A.N.M.M., et al., *New Passive Optical Attenuators to Provide Network Protection, Power Level Control and Fixed Attenuation*, Proceedings of the 57th IWCS (International Wire & Cable Symposium), pp. 240-244, 2008
- [35] SEO, K. et al., *Evaluation of High-power Endurance in Optical Fiber Links*, Furukawa Review, vol. 24, pp. 17-22, 2003
- [36] HAND, D.P. et al., *Single-mode tapers as 'fibre fuse' damage circuit-breakers*, Electron. Lett., vol. 25, no. 1, pp. 33-34, 1989

- [37] YANAGI, S. et al., *Fiber fuse terminator*, The 5th Pacific Rim Conference on Lasers and Electro-Optics, vol. 1, p. 386, 2003
- [38] TAKENAGA, K. et al., *Fiber fuse phenomenon in hole-assisted fibers*, Proceedings of the 34th European Conference on Optical Communication, vol. 5, pp. 27-28, 2008
- [39] TAKARA, H. et al., *Evaluation of fiber fuse characteristics of hole-assisted fiber for high power optical transmission systems*, Proceedings of the 35th European Conference on Optical Communication, p. 312, 2009
- [40] DIANOV, E. M. et al., *Fiber fuse effect in microstructured fibers*, Photon. Technol. Lett. vol.16, pp.180-181, 2004
- [41] HANZAWA, N. et al., *Suppression of fiber fuse propagation in photonic crystal fiber (PCF) and hole assisted fiber (HAF)*, Technical Digest of Microoptics Conference, M7, MOC2009, 2009
- [42] YAMADA, M., et al., *Heating and burning of optical fiber by light scattered from bubble train formed by optical fiber fuse*, Proc. of the Optical Fiber Communication Conference and Exposition and the National (OFC/NFOEC2011), JThA1, 2011
- [43] YAMADA, M., et al., *Light scattering characteristics of a hole formed by a fibre fuse*, Electron. Lett., 48, 9, pp. 519-520, 2012

**Non-cited references**

~~IEC TR 60825-17, Safety of laser products — Part 17: Safety aspects for use of passive optical components and optical cables in high power optical fibre communication systems~~

IECNORM.COM : Click to view the full PDF of IEC TR 61292-4:2023 RLV

# TECHNICAL REPORT



**Optical amplifiers –  
Part 4: Maximum permissible optical power for the damage-free and safe use of  
optical amplifiers, including Raman amplifiers**

IECNORM.COM : Click to view the full PDF of IEC TR 61292-4:2023 RLV

## CONTENTS

|   |    |
|---|----|
| FOREWORD.....   | 4  |
| INTRODUCTION.....   | 6  |
| 1 Scope.....  | 7  |
| 2 Normative references .....  | 7  |
| 3 Terms, definitions, and abbreviated terms .....   | 8  |
| 3.1 Terms and definitions.....  | 8  |
| 3.2 Abbreviated terms.....  | 8  |
| 4 Maximum transmissible optical power to keep fibres damage-free .....  | 8  |
| 4.1 General.....  | 8  |
| 4.2 Fibre fuse and its propagation.....   | 9  |
| 4.3 Loss-induced heating at connectors or splices .....   | 10 |
| 4.4 Connector endface damage induced by dust/contamination .....  | 11 |
| 4.5 Fibre coat burn/melt induced by tight fibre bending .....   | 13 |
| 4.6 Summary of the fibre damage .....   | 14 |
| 5 Maximum transmissible optical power to keep eyes and skin safe .....  | 15 |
| 5.1 Maximum transmissible exposure (MPE) on the surface of eye and skin .....   | 15 |
| 5.2 Maximum permissible optical power in the fibre for the safety of eye and skin.....  | 15 |
| 5.2.1 Power limit.....  | 15 |
| 5.2.2 Need for APR .....  | 16 |
| 5.2.3 Wavelengths.....  | 17 |
| 5.2.4 Locations.....  | 17 |
| 5.2.5 Nominal ocular hazard distance (NOHD).....  | 17 |
| 5.2.6 Power reduction times .....   | 17 |
| 5.2.7 Medical aspects of the safety of eyes and skin in existing standards .....  | 18 |
| 6 Maximum optical power permissible for optical amplifiers from the viewpoint of fibre damage as well as eye and skin safety .....  | 19 |
| 7 Conclusion .....  | 19 |
| Annex A (informative) General information for optical fibre fuse .....  | 20 |
| A.1 Introductory remark.....  | 20 |
| A.2 Generating mechanism .....  | 20 |
| A.3 Void formation mechanism.....   | 24 |
| A.4 Propagation characteristic of a fibre fuse .....  | 24 |
| A.5 Prevention and termination .....  | 26 |
| A.5.1 General .....   | 26 |
| A.5.2 Prevention methods.....   | 26 |
| A.5.3 Termination methods .....   | 27 |
| A.6 Additional safety information .....   | 29 |
| A.7 Conclusion.....   | 29 |
| Bibliography.....   | 30 |
| Figure 1 – Experimental set-up for fibre fuse propagation .....   | 9  |
| Figure 2 – Connection loss versus temperature increase .....  | 11 |
| Figure 3 – Test set-up.....   | 11 |
| Figure 4 – Surface condition contaminated with metal filings, before the test .....   | 12 |
| Figure 5 – Variation of power attenuation during test at several power input values for plugs contaminated with metal filings ..... | 13 |

|   |    |
|---|----|
| Figure 6 – Polishing surface condition contaminated with metal filing, after test.....  | 13 |
| Figure 7 – Thermo viewer image of tightly bent SMF with optical power of 3 W at 1 480 nm .....  | 14 |
| Figure 8 – Temperature of the coating surface of SMFs against bending with optical power of 3 W at 1 480 nm .....   | 14 |
| Figure 9 – Maximum permissible power in the fibre against APR power reduction time .....  | 18 |
| Figure A.1 – Front part of the fibre fuse damage generated in the optical fibre.....  | 20 |
| Figure A.2 – SiO absorption model .....   | 22 |
| Figure A.3 – Calculated fibre fuse propagation behaviour simulated with the SiO absorption model .....  | 23 |
| Figure A.4 – Series of optical micrographs showing damage generated by 9,0 W 1 480 nm laser light suggesting a mechanism of periodic void formation.....      | 24 |
| Figure A.5 – Images of fibre fuse ignition taken with an ultra-high-speed camera and an optical micrograph of the damaged fibre.....                          | 25 |
| Figure A.6 – Power density dependence of the fibre-fuse propagation velocity .....  | 26 |
| Figure A.7 – Optical micrographs showing front part of the fibre fuse damage generated in SMF-28 fibres with various laser intensities (1 480 nm).....        | 26 |
| Figure A.8 – Principle of the optical fibre fuse passive termination method and photograph of a fibre fuse terminator using a TEC structure.....              | 27 |
| Figure A.9 – Photograph of hole-assisted fibre and fibre fuse termination using a hole-assisted fibre .....   | 28 |
| Figure A.10 – Example of fibre fuse active termination scheme.....  | 29 |
| Figure A.11 – Transformation of electrical signal by optical fibre fuse .....   | 29 |
| Table 1 – Threshold power of fibre fuse propagation for various fibres.....   | 9  |
| Table 2 – Measurement conditions.....   | 10 |
| Table 3 – Examples of power limits for optical fibre communication systems having automatic power reduction to reduce emissions to a lower hazard level ..... | 16 |
| Table 4 – Location types within an optical fibre communication system and their typical installations .....   | 17 |

## INTERNATIONAL ELECTROTECHNICAL COMMISSION

## OPTICAL AMPLIFIERS –

**Part 4: Maximum permissible optical power for the damage-free and safe use of optical amplifiers, including Raman amplifiers**

## FOREWORD

- 1) The International Electrotechnical Commission (IEC) is a worldwide organization for standardization comprising all national electrotechnical committees (IEC National Committees). The object of IEC is to promote international co-operation on all questions concerning standardization in the electrical and electronic fields. To this end and in addition to other activities, IEC publishes International Standards, Technical Specifications, Technical Reports, Publicly Available Specifications (PAS) and Guides (hereafter referred to as "IEC Publication(s)"). Their preparation is entrusted to technical committees; any IEC National Committee interested in the subject dealt with may participate in this preparatory work. International, governmental and non-governmental organizations liaising with the IEC also participate in this preparation. IEC collaborates closely with the International Organization for Standardization (ISO) in accordance with conditions determined by agreement between the two organizations.
- 2) The formal decisions or agreements of IEC on technical matters express, as nearly as possible, an international consensus of opinion on the relevant subjects since each technical committee has representation from all interested IEC National Committees.
- 3) IEC Publications have the form of recommendations for international use and are accepted by IEC National Committees in that sense. While all reasonable efforts are made to ensure that the technical content of IEC Publications is accurate, IEC cannot be held responsible for the way in which they are used or for any misinterpretation by any end user.
- 4) In order to promote international uniformity, IEC National Committees undertake to apply IEC Publications transparently to the maximum extent possible in their national and regional publications. Any divergence between any IEC Publication and the corresponding national or regional publication shall be clearly indicated in the latter.
- 5) IEC itself does not provide any attestation of conformity. Independent certification bodies provide conformity assessment services and, in some areas, access to IEC marks of conformity. IEC is not responsible for any services carried out by independent certification bodies.
- 6) All users should ensure that they have the latest edition of this publication.
- 7) No liability shall attach to IEC or its directors, employees, servants or agents including individual experts and members of its technical committees and IEC National Committees for any personal injury, property damage or other damage of any nature whatsoever, whether direct or indirect, or for costs (including legal fees) and expenses arising out of the publication, use of, or reliance upon, this IEC Publication or any other IEC Publications.
- 8) Attention is drawn to the Normative references cited in this publication. Use of the referenced publications is indispensable for the correct application of this publication.
- 9) Attention is drawn to the possibility that some of the elements of this IEC Publication may be the subject of patent rights. IEC shall not be held responsible for identifying any or all such patent rights.

IEC TR 61292-4 has been prepared by subcommittee 86C: Fibre optic systems and active devices, of IEC technical committee 86: Fibre optics. It is a Technical Report.

This fourth edition cancels and replaces the third edition published in 2014. This edition constitutes a technical revision.

This edition includes the following significant technical changes with respect to the previous edition.

- a) The technical information has been updated to reflect revisions of the relevant references.
- b) In particular, the descriptions provided in Clause 5 and Clause 6 have been modified significantly to reflect changes in the cited references. Unnecessary formulas and explanations that overlap with the references have been removed to simplify the document.
- c) New information has been added to Annex A on optical fibre burning when light enters an optical fibre with a bubble train formed by a fibre fuse.

The text of this Technical Report is based on the following documents:

| Draft        | Report on voting |
|--------------|------------------|
| 86C/1821/DTR | 86C/1832/RVDTR   |

Full information on the voting for its approval can be found in the report on voting indicated in the above table.

The language used for the development of this Technical Report is English.

This document was drafted in accordance with ISO/IEC Directives, Part 2, and developed in accordance with ISO/IEC Directives, Part 1 and ISO/IEC Directives, IEC Supplement, available at [www.iec.ch/members\\_experts/refdocs](http://www.iec.ch/members_experts/refdocs). The main document types developed by IEC are described in greater detail at [www.iec.ch/standardsdev/publications](http://www.iec.ch/standardsdev/publications).

A list of all parts in the IEC 61292 series, published under the general title *Optical amplifiers* can be found on the IEC website.

The committee has decided that the contents of this document will remain unchanged until the stability date indicated on the IEC website under [webstore.iec.ch](http://webstore.iec.ch) in the data related to the specific document. At this date, the document will be

- reconfirmed,
- withdrawn,
- replaced by a revised edition, or
- amended.

**IMPORTANT – The "colour inside" logo on the cover page of this document indicates that it contains colours which are considered to be useful for the correct understanding of its contents. Users should therefore print this document using a colour printer.**

## INTRODUCTION

This document is dedicated to the subject of maximally permissible optical power for damage-free and safe use of optical amplifiers, including Raman amplifiers. Since the technology is quite new and still evolving, amendments and new editions to this document can be expected.

Many new types of optical amplifiers are entering the marketplace, and research is also stimulating the development of many new types of fibre and non-fibre based optical amplifiers. With the introduction of new technologies, such as long-haul, beyond 100 Gb/s, WDM transmission, digital coherent transmission and Raman amplification, some optical amplifiers employ optical pump sources with extremely high optical power – possibly up to several Watts. For example, erbium doped fibre amplifiers that provide extremely high output power are described in IEC TR 61292-8 [1]<sup>1</sup>, and Raman amplifiers in IEC TR 61292-6 [2].

Excessively high optical power can cause physical damage to the optical fibres, components and equipment, in addition to presenting a medical hazard to the human eye and skin.

The possibility of fibre damage caused by high optical intensity has been discussed at technical conferences and in technical reports for many years. The use of high intensity optical amplifiers can cause problems in optical fibres, which include fibre fuse, heating in the splice points (connection points), fibre endface damage due to dust, and fibre coat burning due to tight fibre bending. For example, IEC TR 62547 [3] provides guidelines for the measurement of high-power damage sensitivity of single-mode fibre to bends, and IEC TR 62627-01 [4] describes cleaning methods for fibre optic connectors to reduce the risk of fibre endface damage. In addition, other standard groups are discussing the risk of ignition of hazardous environments caused by high-power radiation from optical equipment.

The medical aspects of high-power optical radiation have also been addressed by standards. IEC 60825-2 defines the concept of hazard levels and corresponding labelling, which addresses the safety aspects of lasers specifically in relation to tissue damage.

In addition, IEC TR 60825-17 [5] describes safety measures to protect against effects caused exclusively by thermal, opto-mechanical and related effects in passive optical components and optical cables used in high power optical fibre communication systems. Moreover, ITU-T Recommendation G.664 [6] discusses the safety feature of automatic laser power reduction.

With the recently growing interest in high power fibre amplifiers and fibre Raman amplifiers, however, some difficulties have been identified among optical amplifier users and manufacturers in fully understanding the technical details and requirements across all such standards and agreements.

This document provides a simple informative guideline on the maximum optical power permissible for optical amplifiers for optical amplifier users and manufacturers.

---

<sup>1</sup> Numbers in square brackets refer to the Bibliography.

## OPTICAL AMPLIFIERS –

### Part 4: Maximum permissible optical power for the damage-free and safe use of optical amplifiers, including Raman amplifiers

#### 1 Scope

This part of IEC 61292, which is a Technical Report, applies to all commercially available optical amplifiers (OAs), including optical fibre amplifiers (OFAs) using active fibres as well as Raman amplifiers. Semiconductor optical amplifiers (SOAs) using semiconductor gain media are also included.

This document provides informative guidelines on the threshold of high optical power that can cause high-temperature damage of the fibre. Also discussed is optical safety for manufacturers and users of optical amplifiers by quoting parts of existing standards and agreements on eye and skin safety.

This document identifies the following values for maximum permissible optical power in the optical amplifier for damage-free and safe operation:

- a) the optical power limit that causes thermal damage to the fibre, such as fibre fuse and fibre-coat burning;
- b) the maximum permissible exposure (MPE) to which the eyes/skin can be exposed without consequent injury;
- c) the optical power limit in the fibre that causes MPE on the eyes/skin after free-space propagation from the fibre;
- d) the absolute allowable optical power level for damage-free and safe operation of the optical amplifier by comparing a) and c).

The objective of this document is to minimize potential confusion and misunderstanding in the industry that can cause unnecessary alarms and hinder the progress and acceptance of advancing optical amplifier technologies in the market.

It is important that the reader always refers to the latest international standards and agreements, because the technologies concerned are rapidly evolving.

The present document will be frequently reviewed and updated in a timely manner by incorporating the results of various studies related to OAs and OA-supported optical systems.

#### 2 Normative references

The following documents are referred to in the text in such a way that some or all of their content constitutes requirements of this document. For dated references, only the edition cited applies. For undated references, the latest edition of the referenced document (including any amendments) applies.

IEC 61291-1:2018, *Optical amplifiers – Part 1: Generic specification*

### 3 Terms, definitions, and abbreviated terms

#### 3.1 Terms and definitions

For the purposes of this document, the terms and definitions given in IEC 61291-1:2018 apply.

ISO and IEC maintain terminological databases for use in standardization at the following addresses:

- IEC Electropedia: available at <http://www.electropedia.org/>
- ISO Online browsing platform: available at <http://www.iso.org/obp>

#### 3.2 Abbreviated terms

|        |  |
|--------|--|
| ALS    | automatic laser shutdown                                   |
| APR    | automatic power reduction                                  |
| DSF    | dispersion shifted fibre                                   |
| LOS    | loss of signal   |
| MFD    | mode field diameter  |
| MPE    | maximum permissible exposure                               |
| MPI-R  | single channel receive main path Interface reference point |
| MPI-S  | single channel source main path interface reference point  |
| NOHD   | nominal ocular hazard distance                             |
| NZ-DSF | non-zero dispersion shifted single-mode fibre              |
| OA     | optical amplifier  |
| OFA    | optical fibre amplifier                                    |
| OFCS   | optical fibre communication system                         |
| SMF    | single-mode fibre  |
| SOA    | semiconductor optical amplifier                            |

### 4 Maximum transmissible optical power to keep fibres damage-free

#### 4.1 General

The use and reasonably foreseeable misuse of high intensity optical amplifiers can cause problems in the fibre such as

- a) fibre fuse and its propagation,
- b) heating in splice points/connection points,
- c) fibre endface damage due to dust and other contamination, and
- d) fibre coat burning and ignition of hazardous environments due to tight fibre bending or breakage.

Subclauses 4.2 to 4.5 introduce results concerning the above issues to give guidelines for the damage-free use of optical amplifiers. However, the following results are only valid under the conditions tested, and a higher power could be applied under different conditions.

## 4.2 Fibre fuse and its propagation

The safety of optical amplifiers is discussed from the viewpoint of laser hazard to the eyes and skin and from the viewpoint of fibre damage such as fibre-coat burning and fibre fusing. Subclause 4.2 experimentally analyses the fibre fuse and its propagation caused by high optical power and discusses the threshold power of fibre fuse propagation [7]. Fibre fuse is defined as the phenomenon in which an intense blue-white flash occurs and runs along the fibre toward the high-power light source while forming periodic and/or non-periodic voids.

Figure 1 shows a typical measurement set-up for measuring the threshold power of fibre fuse propagation. The fibre fuse is initiated by heating the optical fibre from outside of the fibre with an independent heat source, while light at high optical power is continuously launched into the fibre. Once the fibre fuse begins propagating, the optical source power is continuously reduced until the fuse propagation stops. Table 1 shows the threshold powers which were measured at various wavelengths of the high-power optical source and for various fibres. Although the threshold power depends on the wavelength of the high-power optical source, the power for the fuse propagation is less than 1,4 W and 1,2 W for a standard single-mode fibre (SMF) and a dispersion shifted fibre (DSF) respectively, which are used as the optical fibre for typical optical fibre communication systems.

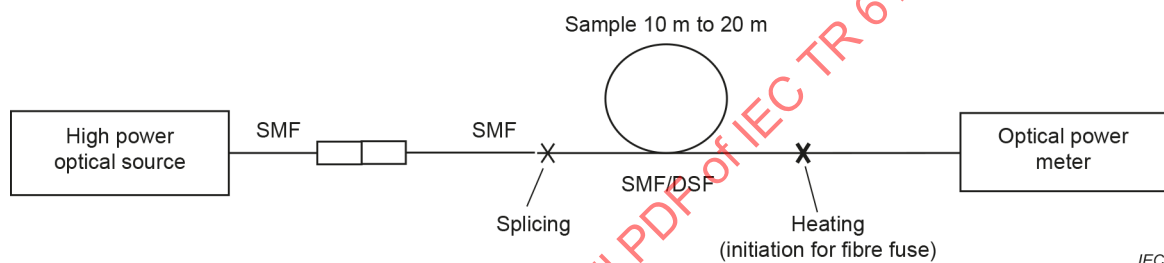

IEC

**Figure 1 – Experimental set-up for fibre fuse propagation**

**Table 1 – Threshold power of fibre fuse propagation for various fibres**

| Fibre type                    | Measurement wavelength | Threshold power of fibre fuse propagation |
|-------------------------------|------------------------|---|
|                               | $\mu\text{m}$          | W   |
| Standard single-mode fibre    | 1,064                  | 1 [8]                                     |
|                               | 1,467                  | 1,4 [8]                                   |
|                               | 1,48                   | ~1,2 [9]                                  |
|                               | 1,55                   | 1,39 [10]                                 |
| Dispersion shifted fibre      | 1,064                  | 1,2 [8]                                   |
|                               | 1,467                  | 0,65 [8]                                  |
|                               | 1,55                   | ~1,1 [11]                                 |
| Dispersion compensation fibre | 1,55                   | ~0,7 [11]                                 |

The difference in fibre mode-field diameter has been identified as the major reason for the difference in the threshold powers because the fibre fuse depends on the power density [7], [8].

On the other hand, it is difficult to identify the threshold power for self-initiated fibre fuse (without any external cause) because it varies significantly. The threshold powers for self-initiated fibre fuse significantly exceed 1,4 W and 1,2 W for standard single-mode fibre (SMF) and dispersion shifted fibre (DSF) respectively.

Further information on the generating mechanism, the characteristics of fibre fuse and the prevention and termination of the fibre fuse are described in Annex A.

### 4.3 Loss-induced heating at connectors or splices

In extremely high-power optical amplifiers, the loss-induced heating at fibres and connectors or splices could lead to damage, including fibre-coat burning, fibre fuse, etc. Subclause 4.2 provides experimental data and considerations for the information of the thermal effects induced by connector and splice losses in high-power amplifiers [12].

Figure 2 shows temperature increase versus connection loss when measured by the conditions shown in Table 2. MU type optical connectors (IEC 61754-6 series [13]) for standard single-mode fibre (SMF) and dispersion shifted fibre (DSF) were used for this measurement. The connector loss was increased by optical fibre misalignment. The optical source used was a 2 W Raman pump at 1 480 nm. The connector temperature was measured by a thermocouple placed on the sleeve. Since the MU ferrule diameter was only 1,25 mm, the sleeve temperature was almost the same as that of the ferrule; ferrule temperature is the most important factor determining the long-term reliability of optical connectors [14].

Larger increases in temperature are observed in DSF rather than in SMF due to higher power density. The result suggests that the temperature increase could be within 10 °C under practical conditions of loss and power. A commercial dry-type connector cleaner was used in every test for cleaning the endface of the connectors.

During repeated connection-disconnection of the connectors, neither damage nor fibre fuse was observed. The experiments in which a cleaner was used identified no problems in terms of fibre/connector damage and reliability. Without the cleaner, however, the experiment with the DSF connector indicated that fibre fuse could occur after repeated connection-disconnection of more than 200 times.

Such temperature increase, and accordingly the danger of fibre fuse, will be worse for non-zero dispersion shifted single-mode fibre (NZ-DSF) connectors than for SMF connectors but better than for DSF connectors, because the effective area of SMFs is typically larger than that of NZ-DSFs, and the effective area of NZ-DSFs is larger than those of DSFs. Further quantitative studies are needed. Other types of physical contact (PC) connectors, like SC connectors (see IEC 61754-4 [15]), show similar temperature responses, because only their ferrule radii differ from MU type connectors.

In conclusion, it is shown that the thermal effects induced by connector and splice losses in high-power amplifiers could be acceptable under any practical conditions foreseeable at this moment. However, it is advisable to eliminate dust and contamination from the connector endfaces and splice points that could locally induce high temperature increases according to the power density absorbed.

**Table 2 – Measurement conditions**

| Parameter               | Conditions                 |
|-------------------------|----------------------------|
| Fibre                   | SMF, DSF                   |
| Connectors              | MU type                    |
| Ferrule                 | Zirconia                   |
| Connector/splice loss   | Imperfect alignment        |
| Wavelength              | Raman pump: 1 480 nm       |
| Power                   | 2 W                        |
| Temperature measurement | Thermocouple on the sleeve |

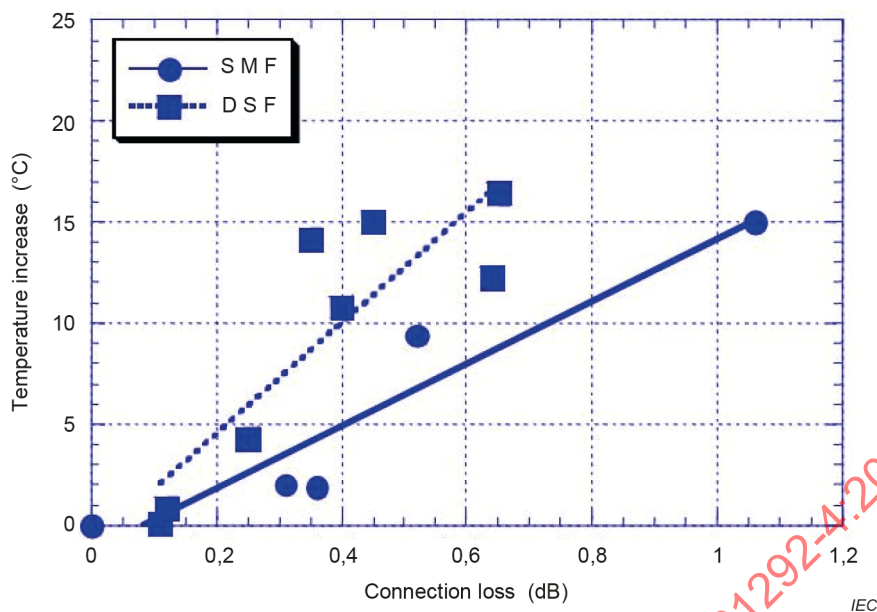

Figure 2 – Connection loss versus temperature increase

#### 4.4 Connector endface damage induced by dust/contamination

The purpose of 4.4 is to show the increase in attenuation of the connector under test when the light power into the fibre is extremely high [16].

Figure 3 shows the scheme of the measurement set-up used in the test. The pump laser of a Raman amplifier is used with a maximum nominal power of 2 W, at a wavelength of 1 455 nm.

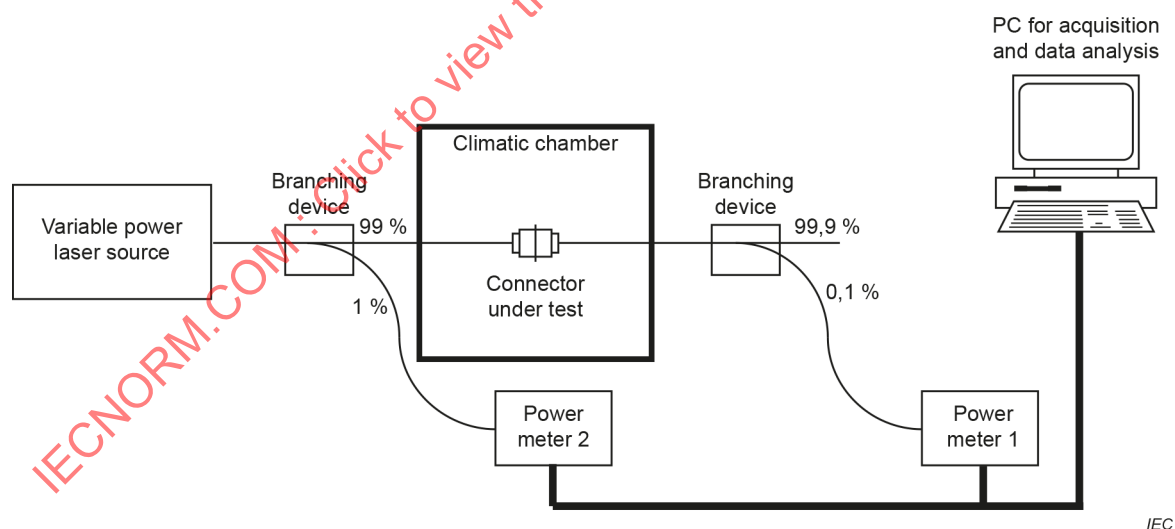

Figure 3 – Test set-up

The optical connectors used are SC-PC type with a perfectly clean surface and with skin grease (from the human operator), dust (from the floor of the lab), and metal filings (from a metallic sleeve) applied.

a) Test result on clean connectors

Two plugs without defects on the polished fibre surface were used. The laser power was increased in steps to 1,2 W after a thorough cleaning. The test was conducted at ambient temperature and in a chamber at 70 °C. During the entire test, the variation of the attenuation was less than 0,02 dB and the visual examination of the fibre surface at the microscope did not show any damage.

b) Test result on connectors contaminated with skin grease

A layer of grease was put down on two plugs without any defect, by simply touching the polished surface with the hands. When increasing the power from 100 mW to 1 200 mW at ambient temperature, the attenuation varied within a few hundredths of a dB. The visual inspection with a microscope after the test showed a cleaning effect, probably due to high temperature near the fibre. After the surface cleaning, no damage was observed.

c) Test result on connectors contaminated with dust

In this case, dust from the laboratory floor was put on the polished surface of the plugs. After the initial increase of the attenuation from a normalized value of 0 dB to 0,06 dB with 200 mW input power, the attenuation started to decrease with the increase in the power until –0,15 dB with 1,2 W input power. This effect of improvement in power transmission could be due to a cleaning action of the high temperature on the finest particles. Also, in this case, after the cleaning at the end of the test, the surfaces did not show any damage.

d) Test result on connectors contaminated with metal dust

In this test, metal dust obtained by filing a metallic sleeve of an adapter was put down on the plug surfaces. This condition simulates the presence of metallic particles produced by the friction of the ferrule during the insertion into a metallic sleeve.

A first test was performed by heavily contaminating the surfaces, as Figure 4 shows. The heavy contamination is evident from the initial attenuation value, which was 3 dB to 4 dB higher than the ones obtained for the other conditions.

During the test, already at 200 mW, the attenuation increased by about 0,3 dB. At the 400 mW step, the damage became evident as the attenuation increased to 1,1 dB (see Figure 5). As failure occurred, the test was stopped to visually inspect the surfaces.

Obvious signs of burning were observed on the core of both fibres that could not be eliminated by cleaning the surface. The visual inspection of polished surface through a microscope (Figure 6) shows fused metal embedded on the fibre cores. These contaminations are not removable by cleaning the surfaces.

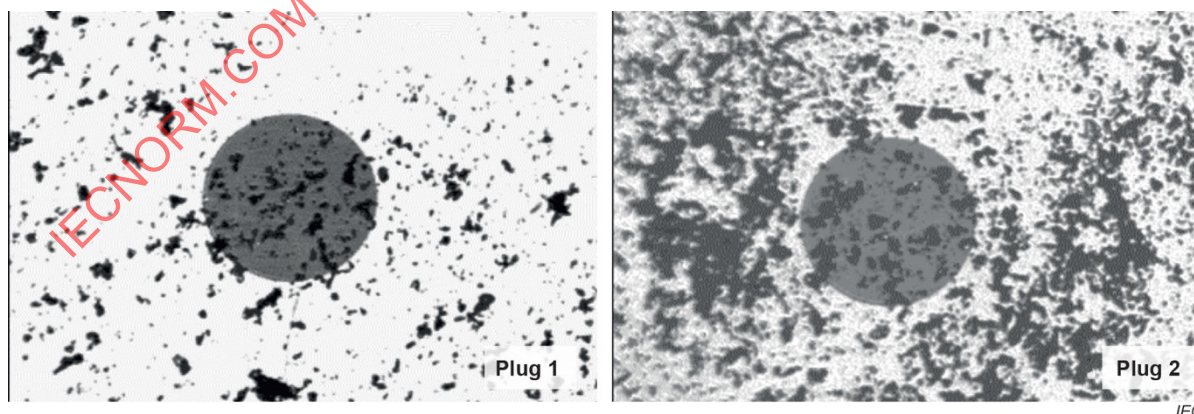
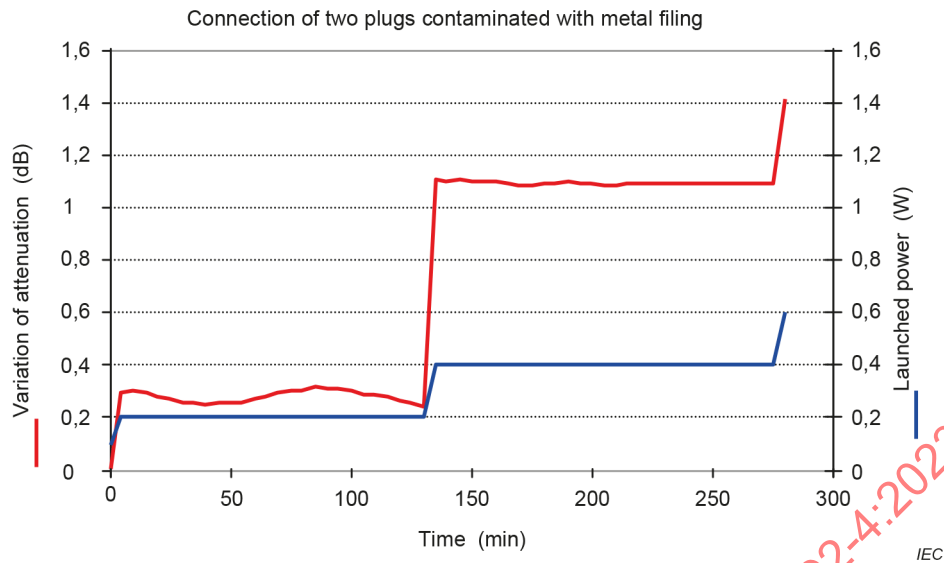
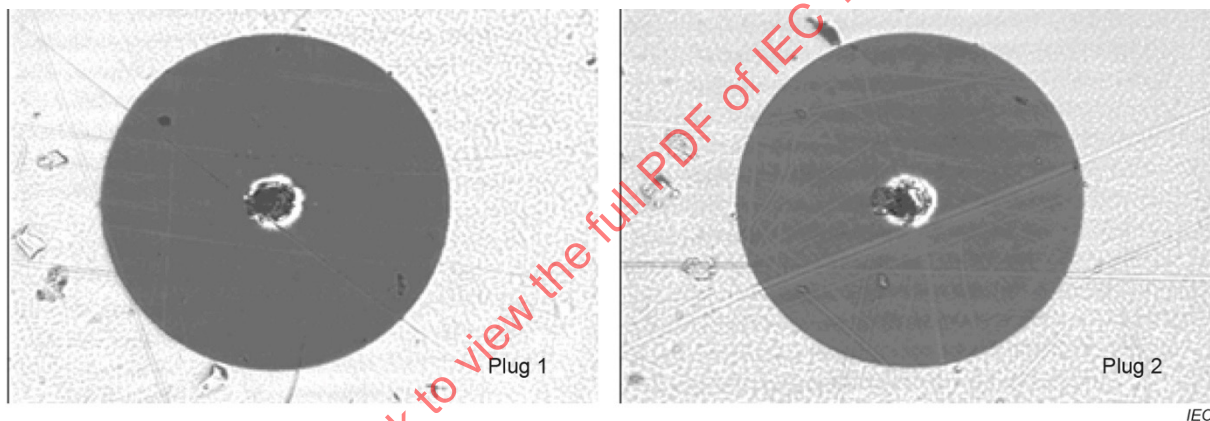

Figure 4 – Surface condition contaminated with metal filings, before the test



**Figure 5 – Variation of power attenuation during test at several power input values for plugs contaminated with metal filings**



**Figure 6 – Polishing surface condition contaminated with metal filing, after test**

In conclusion, it was confirmed that there is no damage risk to the connectors due to high optical power under the conditions tested, if the connectors are correctly used and handled. In particular, it is not advisable to ever open connectors while high optical power is passing through them. However, a correct cleaning procedure and visual analysis of the polished connector surface is fundamental for a good and reliable network, particularly when metallic sleeves are used.

#### 4.5 Fibre coat burn/melt induced by tight fibre bending

Subclause 4.5 provides some examples of the fibre coat burn or melt induced by tight fibre bending [8]. The fibre coatings used were

- a) UV curable resin: white, blue, green, and uncoloured, and
- b) nylon white.

The fibre used was single-mode (SMF).

By using a thermo viewer image of the bent fibre, the highest temperature at the surface of each fibre coating was measured. Figure 7 shows an image of the tightly bent fibre with an optical power of 3 W at 1 480 nm. Shown in Figure 8 is the temperature at the coating surface versus bending diameter for 3 W at 1 480 nm. The temperature of the nylon coat surface reached 150 °C or higher; the nylon coating melted or even burned. The nylon coat burned in the test after the fibre break at the point where the fibre coat melted.

By considering the test results together with the long-term reliability degradation of coated SMF, it is suggested that the coated fibre bend diameter be kept at more than 20 mm and more than 30 mm for optical powers of 1 W and 3 W, respectively, under the conditions tested. Another test revealed that transparent UV resin was more durable than coloured UV resin against tight bending.

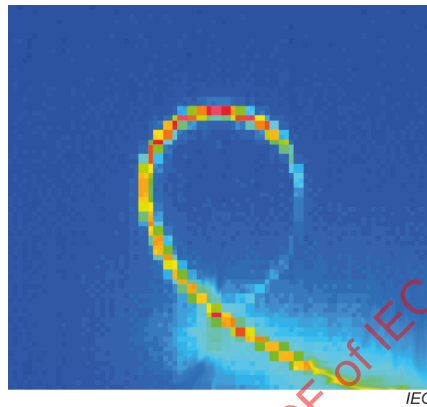

Figure 7 – Thermo viewer image of tightly bent SMF with optical power of 3 W at 1 480 nm

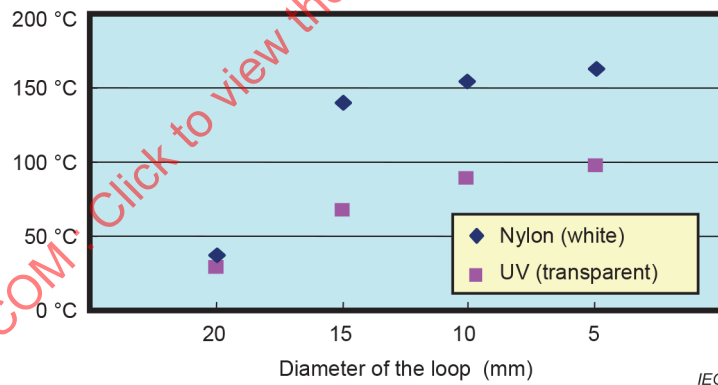

Figure 8 – Temperature of the coating surface of SMFs against bending with optical power of 3 W at 1 480 nm

#### 4.6 Summary of the fibre damage

In 4.2, it was found that fibre fuse, once it was initiated for any reason, propagated if the input signal power was higher than 1,4 W and 1,2 W for SMF and DSF, respectively, under the conditions tested. However, it is not advisable to even momentarily push the fibre across a sharp edge that could induce a tight bend and trigger fibre fuse even at a lower power than the above.

In 4.3, it was shown that the thermal effects induced by the connector and splice losses in high-power amplifiers could be acceptable under any practical conditions.

In 4.4, the connectors were tested with the input powers up to 1,2 W. It was found that the only case that caused permanent damage to the fibre core was when surfaces were contaminated with metal particles.

In 4.5, fibre coat burning induced by fibre tight bending was addressed. It is suggested that the bend diameter of coated fibre be kept over 20 mm and 30 mm for optical powers of 1 W and 3 W, respectively, under the conditions tested.

Based on 4.2 to 4.5, it is concluded that power levels up to at least 1,2 W can be used without damaging OAs. The actual upper limit of the power is under study by considering, for example, the types of fibre and cleanliness of the fibre endfaces.

In addition, IEC TR 62627-01 [4] describes methods to prevent damage to the connector, and IEC TR 62547 [3] describes methods to measure the damage of fibre tight bending.

## **5 Maximum transmissible optical power to keep eyes and skin safe**

### **5.1 Maximum transmissible exposure (MPE) on the surface of eye and skin**

In IEC 60825-1, MPE is defined as the "level of laser radiation to which, under normal circumstances, persons may be exposed without suffering adverse effects" [17]. The MPE values used by IEC have been specified in the ANSI-Z136 series [18] and are based on non-human experiments. IEC TR 60825-14 gives more details on MPE [19].

IEC 60825-2 includes the following text in which it is requested that optical fibre communication systems (OFCSs) be designed not to exceed the MPE, including the time period before an automatic power reduction (APR) system completes its function [20]:

"Where the OFCS uses an APR feature to meet the limits of a hazard level that is lower than that which would have to be assigned if no APR feature would be present, the irradiance or radiant exposure during the maximum time to reach the lower hazard level [...] (not greater than 1 s for unrestricted, 3 s for restricted or controlled locations) shall not exceed the irradiance or radiant exposure limits for either the eye or skin (equivalent to MPEs for the eye and skin), corresponding to the shut-down period of the APR. For unrestricted/restricted locations and controlled locations the measurement distances are 100 mm and 250 mm, respectively, for this subclause [i.e., IEC 60825-2:2021, 4.7.4] only."

NOTE In the text described in IEC 60825-2, there is a sentence with a clause number, but in the above text, that number is deleted.

In IEC 60825-2 [20], the hazard levels of laser products, including OAs, are determined based on the classification rule of IEC 60825-1 [17]. In the existing standards, automatic laser shutdown (ALS) could have the same meaning as APR.

### **5.2 Maximum permissible optical power in the fibre for the safety of eye and skin**

#### **5.2.1 Power limit**

Table 3 shows examples of power limits for unrestricted, restricted and controlled access (see 5.2.4) of OFCSs that employ APR to reduce the power to a lower hazard level, which is described with reference to IEC 60825-2:2021, Table D.3 [20]. It is worthwhile noting that the maximum permissible optical power in such OAs can be increased by reducing the power reduction time of the APR (the shut down time).

**Table 3 – Examples of power limits for optical fibre communication systems having automatic power reduction to reduce emissions to a lower hazard level**

| Wavelength     | MFD | Maximum power output unrestricted | Maximum power output restricted | Maximum power output controlled | Shutdown times | Measurement distance |
|----------------|-----|-----------------------------------|---------------------------------|---------------------------------|----------------|----------------------|
| nm             | µm  | mW                                | mW                              | mW                              | s              | m                    |
| 980            | 7   | 9,4                               | 9,4                             | N/A                             | 1              | 0,1                  |
| 980            | 7   | N/A                               | 7,2                             | N/A                             | 3              | 0,1                  |
| 980            | 7   | N/A                               | N/A                             | 39                              | 3              | 0,25                 |
| 1 310          | 11  | 2 587                             | 2 587                           | N/A                             | 1              | 0,1                  |
| 1 310          | 11  | N/A                               | 1 966                           | N/A                             | 3              | 0,1                  |
| 1 310          | 11  | N/A                               | N/A                             | 10 347                          | 3              | 0,25                 |
| 1 400 to 1 500 | 11  | 1 598                             | 1 598                           | N/A                             | 0,3            | 0,1                  |
| 1 400 to 1 500 | 11  | 650                               | 650                             | N/A                             | 1              | 0,1                  |
| 1 400 to 1 500 | 11  | N/A                               | 389                             | N/A                             | 2              | 0,1                  |
| 1 400 to 1 500 | 11  | N/A                               | 288                             | N/A                             | 3              | 0,1                  |
| 1 400 to 1 500 | 11  | N/A                               | N/A                             | 2 403                           | 2              | 0,25                 |
| 1 400 to 1 500 | 11  | N/A                               | N/A                             | 1 774                           | 3              | 0,25                 |
| 1 550          | 11  | 2 539                             | 2 539                           | N/A                             | 0,5            | 0,1                  |
| 1 550          | 11  | 1 273                             | 1 273                           | N/A                             | 1              | 0,1                  |
| 1 550          | 11  | N/A                               | 639                             | N/A                             | 2              | 0,1                  |
| 1 550          | 11  | N/A                               | 428                             | N/A                             | 3              | 0,1                  |
| 1 550          | 11  | N/A                               | N/A                             | 2 640                           | 3              | 0,25                 |

Source: IEC 60825-2:2021, Table D.3 [20].

NOTE 1 The fibre parameters used are the most conservative case. Listed figures for  $\lambda = 1\ 310\ \text{nm}$  to  $1\ 550\ \text{nm}$  are calculated for a fibre with  $11\ \mu\text{m}$  MFD and those for  $\lambda = 980\ \text{nm}$  are for  $7\ \mu\text{m}$  MFD. Many systems operating at  $1\ 550\ \text{nm}$  with erbium-doped fibre amplifiers (EDFAs) pumped by  $1\ 480\ \text{nm}$  or  $980\ \text{nm}$  lasers use transmission fibres with smaller MFDs. For example,  $1\ 550\ \text{nm}$  dispersion shifted fibre cables have upper limit MFD values of  $9,1\ \mu\text{m}$ .

NOTE 2 Times given in the table are examples. The shutdown times shown include shorter times than the maximum. Shorter shutdown times enable the use of higher powers. The maximum times are  $1\ \text{s}$  for unrestricted locations and  $3\ \text{s}$  for restricted and controlled locations, respectively.

NOTE 3 The high-power density in an optical fibre cable can cause fibre fuse, which leads to high temperature along the fibre cable.

For these power limits, it is assumed that the user does not employ any optical instrument or viewing optics within the beam. When optical instruments or viewing optics are not used, devices classified as 1M are considered safe under the conditions indicated in IEC 60825-1 [17]. However, they can be hazardous if the user employs optical instruments or viewing optics within the beam.

### 5.2.2 Need for APR

ITU-T Recommendation G.664:2012, Appendix II, suggests that APR is needed not only on the main optical signal sources but also on all pump-lasers employed [6]. It specifically states:

"[In particular,] distributed Raman amplification systems will need specific care to ensure optically safe working conditions, because high pump powers (power levels above +30 dBm are not uncommon) may be injected in optical fibre cables. Therefore, APR procedures [are required in order to] avoid hazards from laser radiation to human eye or skin and potential additional hazards such as temperature increase (or even fire) caused by local increased absorption due to connector pollution/damages [or very tight fibre bends].

[...]

In order to ensure that the power levels emitting from broken or open fibres connections are at safe levels, it is necessary to reduce the power not only on the main optical signal sources but also on all pump-lasers employed, in particular the backward pumping lasers."

### 5.2.3 Wavelengths

When determining the safe limit of the optical amplifier power set by the MPE limit, it is advisable to include the main optical signal power, the pump-laser powers, and the optical supervisory channel power, if used.

### 5.2.4 Locations

Table 4 shows location types within an optical fibre communication system and their typical installations. See IEC 60825-2 for more details [20].

**Table 4 – Location types within an optical fibre communication system and their typical installations**

| Location type       | Typical installation<br>(informative)  |
|---------------------|--|
| Unrestricted access | Domestic premises, services industries that are open to the general public (e.g. shops and hotels), public areas on trains, ships or other vehicles, open public areas such as parks, streets, etc., non-secured areas within business/industrial/commercial premises where members of the public are permitted to have access, such as some office environments |
| Restricted access   | Secured areas within industrial premises not open to the public, secured areas within business/commercial premises not open to the public (for example telephone private automatic branch exchange (PABX) rooms, computer system rooms, etc.), general areas within switching centres, delimited areas not open to the public on trains, ships or other vehicles |
| Controlled access   | Cable ducts, street cabinets, dedicated and delimited areas of distribution centres, test rooms in cable ships   |

### 5.2.5 Nominal ocular hazard distance (NOHD)

In controlled locations, NOHD at which the level of exposure drops to the MPE for the eye is 25 cm, because personnel is expected to be trained to keep the 25 cm distance. Otherwise, the NOHD is 10 cm, because the minimum focal distance for the human eye is generally known to be 10 cm.

### 5.2.6 Power reduction times

Power reduction time is the maximum time span after the incident before the APR completes its task. ITU-T Recommendation G.664 suggests, as information, the power reduction times for OAs in multi-vender systems. For systems without line amplifiers, the APR time suggested is less than 800 ms, and that for OAs in systems with line amplifiers is less than 3 s, as described in ITU-T Recommendation G.664:2012, Appendix II [6]:

"After at least 500 ms of continuous presence of the LOS (loss of signal) defect, the actual shutdown command will be activated, which shall result in reduction of the optical output power at MPI-S [(single channel source main path interface reference point)] within 800 ms from the moment loss of optical signal occurs at MPI-R [(single channel receive main path interface reference point)].

[...]

In order to avoid exposure to hazardous optical power levels, all amplifiers (boosters and line amplifiers) shall have sufficiently short deactivation times to accommodate shutdown of all amplifiers between MPI-S and MPI-R within 3 s from the moment the actual connection interruption occurs.

NOTE 1 Depending on the actual operational power, the 3 s shutdown time (defined in the past) might not be fast enough. A check against IEC 60825-1 [...] is recommended."

Within the above limit, the maximum permissible optical power shown in Table 3 can be increased if the power reduction time for the APR can be shortened. Figure 9 shows the maximum permissible power in the fibre against APR power reduction times.

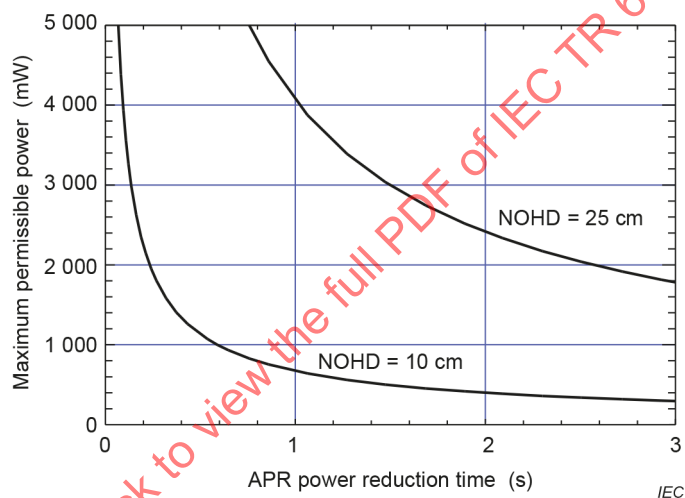

NOTE 1 In the restricted/controlled area, the OA classification is determined based on the optical power measured 3 s after the incident.

NOTE 2 Fibre mode field diameter = 11 µm, wavelength = 1 480 nm.

**Figure 9 – Maximum permissible power in the fibre against APR power reduction time**

### 5.2.7 Medical aspects of the safety of eyes and skin in existing standards

Concerning the medical aspects of the safety of eyes and skin, the following information is found in IEC TR 60825-14 [19].

- a) The retinal hazard region is typically understood as 400 nm to 1 400 nm.
- b) The pupil diameter used here is 7 mm assuming a dark room, although it is 4 mm to 5 mm in a regular room.
- c) From 1 400 nm to 1 500 nm, for exposure time  $t = 1$  ms to 10 s, the MPE values are the same for cornea and skin, being given as  $5\,600 \cdot t \cdot 0,25 \text{ Jm}^{-2}$ . However, the consequences of injury to the eyes are usually much more serious than equivalent injuries to the skin.
- d) There is no "eye-safe" wavelength band.

Infrared light with a wavelength  $> 1\,400$  nm (or sometimes  $> 1\,300$  nm) normally does not penetrate into the eye but causes damage to the cornea. It is also understood that visible light (400 nm to 700 nm) and light  $\leq 1\,400$  nm penetrate and cause damage to the retina. It is also known that retina damage is normally incurable: retinal cells do not re-grow.

## 6 Maximum optical power permissible for optical amplifiers from the viewpoint of fibre damage as well as eye and skin safety

Based on 4.2 to 4.5, it was concluded in 4.6 that power levels up to at least 1,2 W can be used without damaging fibres under the conditions tested if the following conditions apply:

- the fibre bend diameter is more than 20 mm;
- the connectors are kept "clean".

Next, from the viewpoint of eyes and skin safety, it was understood from 5.2 that pump powers in the 1 480 nm range for distributed Raman amplifiers can go up to 1,77 W or 2,59 W depending on the fibre mode field diameter (see Table 3) for the pump APR time of 3 s, if the high intensity light could leak only within controlled locations. With APR times shorter than 3 s, higher power can be applied.

It can then be concluded that the maximum optical power permissible for the damage-free and safe use of optical amplifiers can go up to at least 1,2 W, within controlled locations under the conditions shown in this document and with the APR time shorter than 3 s. The actual upper limit of the power is under study by considering, for example, the types of fibre and cleanliness of the fibre endfaces.

However, where there is potential light leakage due to, for example, a fibre break, it is important to take precautions so that a system operating with an optical power of 1,2 W does not exceed permitted hazard levels (see IEC 60825-2 [20]). APR can be used to limit optical power to a suitable level. Moreover, it is noted that, although signal power in the 1 550 nm range is generally much less than Raman pump power, signal power cannot always be neglected for OA safety and damage.

## 7 Conclusion

It is concluded under the conditions tested and considered that the optical power permissible for the damage-free and safe use of optical amplifiers can go up to at least 1,2 W for controlled locations when APR times are shorter than 3 s.

Since the technologies are constantly evolving, it is requested that the reader refers to the latest edition of IEC 61292-4 as well as to the latest editions of the relevant documents cited in this document.