

TECHNICAL SPECIFICATION



**Design of earth electrode stations for high-voltage direct current (HVDC) links –
General guidelines**

IECNORM.COM : Click to view the full PDF of IEC TS 62344:2013



THIS PUBLICATION IS COPYRIGHT PROTECTED
Copyright © 2013 IEC, Geneva, Switzerland

All rights reserved. Unless otherwise specified, no part of this publication may be reproduced or utilized in any form or by any means, electronic or mechanical, including photocopying and microfilm, without permission in writing from either IEC or IEC's member National Committee in the country of the requester.

If you have any questions about IEC copyright or have an enquiry about obtaining additional rights to this publication, please contact the address below or your local IEC member National Committee for further information.

IEC Central Office
3, rue de Varembe
CH-1211 Geneva 20
Switzerland

Tel.: +41 22 919 02 11
Fax: +41 22 919 03 00
info@iec.ch
www.iec.ch

About the IEC

The International Electrotechnical Commission (IEC) is the leading global organization that prepares and publishes International Standards for all electrical, electronic and related technologies.

About IEC publications

The technical content of IEC publications is kept under constant review by the IEC. Please make sure that you have the latest edition, a corrigenda or an amendment might have been published.

Useful links:

IEC publications search - www.iec.ch/searchpub

The advanced search enables you to find IEC publications by a variety of criteria (reference number, text, technical committee,...).

It also gives information on projects, replaced and withdrawn publications.

IEC Just Published - webstore.iec.ch/justpublished

Stay up to date on all new IEC publications. Just Published details all new publications released. Available on-line and also once a month by email.

Electropedia - www.electropedia.org

The world's leading online dictionary of electronic and electrical terms containing more than 30 000 terms and definitions in English and French, with equivalent terms in additional languages. Also known as the International Electrotechnical Vocabulary (IEV) on-line.

Customer Service Centre - webstore.iec.ch/csc

If you wish to give us your feedback on this publication or need further assistance, please contact the Customer Service Centre: csc@iec.ch.

IECNORM.COM : Click to view the full PDF of IEC TS 62944:2013

TECHNICAL SPECIFICATION



**Design of earth electrode stations for high-voltage direct current (HVDC) links –
General guidelines**

INTERNATIONAL
ELECTROTECHNICAL
COMMISSION

PRICE CODE **XC**

ICS 29.240.99

ISBN 978-2-83220-575-4

Warning! Make sure that you obtained this publication from an authorized distributor.

CONTENTS

FOREWORD.....	7
INTRODUCTION.....	9
1 Scope.....	10
2 Normative references.....	10
3 Terms and definitions.....	10
3.22 current-releasing density.....	13
4 System conditions.....	14
4.1 General principles.....	14
4.2 System parameters related to earth electrode design.....	14
4.2.1 Amplitude and duration of the current.....	14
4.2.2 Polarity.....	14
4.2.3 Designed lifespan.....	15
4.2.4 Common earth electrodes.....	15
5 Design of land electrode stations.....	15
5.1 Main technical parameters.....	15
5.1.1 General principles.....	15
5.1.2 Temperature rise.....	16
5.1.3 Earthing resistance.....	16
5.1.4 Step voltage.....	17
5.1.5 Touch voltage.....	17
5.1.6 Current density.....	17
5.1.7 Field intensity in fish ponds.....	18
5.2 Electrode site selection and parameter measurement.....	18
5.2.1 General principles.....	18
5.2.2 Data collection survey.....	18
5.2.3 Distance from converter station (substation).....	18
5.2.4 Environment conditions.....	19
5.2.5 Terrain and landform.....	19
5.2.6 Measurement of soil parameters.....	19
5.2.7 Geological exploration.....	19
5.2.8 Topographical map.....	19
5.2.9 Values selected during design.....	19
5.3 Earth electrode and associated components.....	20
5.3.1 General principles for material selection.....	20
5.3.2 Selection of feeding rods and characteristics.....	20
5.3.3 Chemical and physical properties of petroleum coke.....	21
5.3.4 Current-guiding system.....	21
5.3.5 Bus.....	22
5.3.6 Electrode line monitoring device.....	22
5.4 Electrode arrangement.....	22
5.4.1 General principles.....	22
5.4.2 Filling coke.....	22
5.4.3 Selection of earth electrode shape.....	22
5.4.4 Earth electrode corridor (right of way).....	23
5.4.5 Distance between sub-electrodes in the arrangement.....	23
5.4.6 Burial depth of the earth electrodes.....	23

5.4.7	Segmentation of earth electrodes	24
5.5	Minimum size of earth electrode	24
5.5.1	General principles	24
5.5.2	Total earth electrode length	24
5.5.3	Side length of coke section	24
5.5.4	Diameter of feeding rods	25
5.6	Current guiding system	26
5.6.1	General principles	26
5.6.2	Placement of the current-guiding wire	26
5.6.3	Connection of current-guiding wire	26
5.6.4	Selection of current-guiding wire cross-section	27
5.6.5	Insulation of the current-guiding wire	27
5.6.6	Disconnecting switch	27
5.6.7	Connection of the feeding cable	27
5.6.8	Connection of jumper cables	28
5.6.9	Selection of cable structure	28
5.6.10	Selection of cable cross-section	28
5.6.11	Selection of cable insulation	28
5.6.12	Cable welding position	29
5.6.13	Welding	29
5.6.14	Mechanical protection for cable	29
5.7	Auxiliary facilities	29
5.7.1	Online monitoring	29
5.7.2	Soil treatment	29
5.7.3	Exhaust equipment	30
5.7.4	Fence	30
5.7.5	Marker	30
6	Design of sea electrode station and shore electrode station	30
6.1	Main technical parameters	30
6.1.1	Temperature rise	30
6.1.2	Earthing resistance	30
6.1.3	Step voltage	31
6.1.4	Touch voltage	32
6.1.5	Voltage gradient in water	32
6.1.6	Current density	32
6.2	Electrode site selection and parameter measurement	32
6.2.1	General principles	32
6.2.2	Data collection survey	32
6.2.3	Distance from converter station (substation)	32
6.2.4	Environment conditions	33
6.2.5	Measurement of soil parameters	33
6.3	Earth electrode and associated components	33
6.3.1	General principles for material selection	33
6.3.2	Common feeding rods and characteristics	33
6.3.3	Chemical properties of petroleum coke	34
6.3.4	Current-guiding system	34
6.3.5	Bus	34
6.3.6	Electrode line monitoring device	34
6.4	Electrode arrangement	34

6.4.1	General principles	34
6.4.2	Filling coke	34
6.4.3	Selection of earth electrode shape.....	34
6.4.4	Segmentation of earth electrodes	35
6.5	Current-guiding system	35
6.5.1	Placement of the current-guiding wire.....	35
6.5.2	Connection of current-guiding system.....	35
6.5.3	Selection of cable cross-section	36
6.5.4	Insulation of the current-guiding system	36
6.5.5	Selection of cable structure	36
6.5.6	Mechanical protection for cable	36
6.6	Auxiliary facilities	36
7	Impact on surrounding facilities and mitigation measures	37
7.1	Impact on insulated metallic structures and mitigation measures	37
7.1.1	General principles	37
7.1.2	Relevant limits.....	37
7.1.3	Mitigation measures	37
7.2	Impact on bare metallic structures	37
7.2.1	General principles	37
7.2.2	Relevant limits.....	37
7.2.3	Mitigation measures	37
7.3	Impact on the power system (power transformer, grounding network, and surrounding towers).....	38
7.3.1	General principles	38
7.3.2	Relevant limits.....	38
7.3.3	Mitigation measures	38
7.4	Impact on electrified railway.....	38
7.5	Other facilities (such as greenhouses and water pipes)	39
Annex A (informative)	Basic concepts of earth electrodes	40
Annex B (informative)	Soil parameter measurement method	52
Annex C (informative)	Electrode line design.....	60
Annex D (informative)	Assessment of measurement method	63
Annex E (informative)	Earth electrode electrical parameter calculation method	67
Annex F (informative)	Thermal time constant	78
Annex G (informative)	Schematic diagram of online monitoring system.....	80
Annex H (informative)	Calculation method for corrosion of nearby metal structures caused by earth electrodes	81
Annex I (informative)	Calculation method for d.c. current flowing through a.c. transformer neutral near earth electrodes	83
Annex J (informative)	Chemical aspects	86
Annex K (informative)	Simple introduction of shore electrodes	87
Bibliography.....		89
Figure 1 – Electrode cross-section		22
Figure 2 – Vertical arrangement.....		23
Figure 3 – Placement of the current-guiding wire		26
Figure 4 – Feeding cable		28

Figure 5 – Resistivity layers with sea or shore electrodes	31
Figure 6 – Sea electrode	34
Figure 7 – Sea bottom electrode with titanium nets	35
Figure 8 – Titanium net	36
Figure 9 – Impact of earth electrodes on a.c. systems (transformer, grounding network, tower)	38
Figure A.1 – HVDC power transmission system structure	40
Figure A.2 – Schematic diagram of the structure of a monopolar earth (sea water) return system	41
Figure A.3 – Schematic diagram of the structure of monopolar metallic return system	41
Figure A.4 – Schematic diagram of the structure of bipolar neutral grounded at both ends	42
Figure A.5 – Schematic diagram of the structure of bipolar neutral grounded at one end	42
Figure A.6 – Schematic diagram of the structure of bipolar neutral line	43
Figure A.7 – Schematic diagram of touch voltage and step voltage	44
Figure A.8 – Schematic diagram of single circular earth electrode	45
Figure A.9 – Axial distribution of step voltage of single circular earth electrode	45
Figure A.10 – 3-D distribution of step voltage of single circular earth electrode	46
Figure A.11 – Schematic diagram of double circular earth electrode	46
Figure A.12 – Axial distribution of step voltage of double circular earth electrode	46
Figure A.13 – 3-D distribution of step voltage of double circular earth electrode	47
Figure A.14 – Schematic diagram of triple circular earth electrode	47
Figure A.15 – Axial distribution of step voltage of triple circular earth electrode	47
Figure A.16 – 3-D distribution of step voltage of triple circular earth electrode	48
Figure B.1 – Equivalent circuit of Wenner method	54
Figure B.2 – Equivalent circuit of Schlumberger method	54
Figure B.3 – Equivalent circuit of dipole-dipole method	55
Figure E.1 – π shape equivalent circuit of an individual earth electrode unit	67
Figure E.2 – Ohm's Law applied to cylinder conductor	68
Figure E.3 – Continuity of axial component of the electric field in the soil and in the conductor	68
Figure E.4 – Spatial division of the earth electrode	68
Figure E.5 – Network for solving axis current	69
Figure E.6 – Horizontally layered soil	71
Figure E.7 – Geometrical structure of a tetrahedron unit	72
Figure E.8 – Structure of a double-circle d.c. earth electrode	76
Figure E.9 – Ground potential and step voltage distribution of a double-circle earth electrode	77
Figure F.1 – Earth electrode temperature rise characteristics	78
Figure G.1 – Schematic diagram of earth electrode online monitoring system	80
Figure H.1 – Calculation of current flowing through a metal pipe	82
Figure I.1 – Schematic diagram of ground resistance network and underground voltage source	83
Figure I.2 – Circuit model for the analysis of d.c. distribution of a.c. systems	85
Figure K.1 – Top view of shore electrode, beach type	87

Figure K.2 – Shore electrode, pond type 87

Table 1 – Composition of iron-silicon alloy electrode..... 21

Table 2 – Chemical composition of the coke after calcination..... 21

Table 3 – Physical properties of petroleum coke used for earth electrodes 21

Table 4 – Electric corrosion characteristics of different materials 26

Table B.1 – Soil (rock) resistivity..... 52

Table B.2 – Soil thermal capacity..... 53

Table B.3 – Soil thermal conductivity 53

Table B.4 – Number of measurement points with different pole distances 56

Table E.1 – Model of soil with two layers 77

IECNORM.COM : Click to view the full PDF of IEC TS 62344:2013

INTERNATIONAL ELECTROTECHNICAL COMMISSION

**DESIGN OF EARTH ELECTRODE STATIONS
FOR HIGH-VOLTAGE DIRECT CURRENT (HVDC) LINKS –
GENERAL GUIDELINES**

FOREWORD

- 1) The International Electrotechnical Commission (IEC) is a worldwide organization for standardization comprising all national electrotechnical committees (IEC National Committees). The object of IEC is to promote international co-operation on all questions concerning standardization in the electrical and electronic fields. To this end and in addition to other activities, IEC publishes International Standards, Technical Specifications, Technical Reports, Publicly Available Specifications (PAS) and Guides (hereafter referred to as "IEC Publication(s)"). Their preparation is entrusted to technical committees; any IEC National Committee interested in the subject dealt with may participate in this preparatory work. International, governmental and non-governmental organizations liaising with the IEC also participate in this preparation. IEC collaborates closely with the International Organization for Standardization (ISO) in accordance with conditions determined by agreement between the two organizations.
- 2) The formal decisions or agreements of IEC on technical matters express, as nearly as possible, an international consensus of opinion on the relevant subjects since each technical committee has representation from all interested IEC National Committees.
- 3) IEC Publications have the form of recommendations for international use and are accepted by IEC National Committees in that sense. While all reasonable efforts are made to ensure that the technical content of IEC Publications is accurate, IEC cannot be held responsible for the way in which they are used or for any misinterpretation by any end user.
- 4) In order to promote international uniformity, IEC National Committees undertake to apply IEC Publications transparently to the maximum extent possible in their national and regional publications. Any divergence between any IEC Publication and the corresponding national or regional publication shall be clearly indicated in the latter.
- 5) IEC itself does not provide any attestation of conformity. Independent certification bodies provide conformity assessment services and, in some areas, access to IEC marks of conformity. IEC is not responsible for any services carried out by independent certification bodies.
- 6) All users should ensure that they have the latest edition of this publication.
- 7) No liability shall attach to IEC or its directors, employees, servants or agents including individual experts and members of its technical committees and IEC National Committees for any personal injury, property damage or other damage of any nature whatsoever, whether direct or indirect, or for costs (including legal fees) and expenses arising out of the publication, use of, or reliance upon, this IEC Publication or any other IEC Publications.
- 8) Attention is drawn to the Normative references cited in this publication. Use of the referenced publications is indispensable for the correct application of this publication.
- 9) Attention is drawn to the possibility that some of the elements of this IEC Publication may be the subject of patent rights. IEC shall not be held responsible for identifying any or all such patent rights.

The main task of IEC technical committees is to prepare International Standards. In exceptional circumstances, a technical committee may propose the publication of a technical specification when

- the required support cannot be obtained for the publication of an International Standard, despite repeated efforts, or
- the subject is still under technical development or where, for any other reason, there is the future but no immediate possibility of an agreement on an International Standard.

Technical specifications are subject to review within three years of publication to decide whether they can be transformed into International Standards.

IEC 62344, which is a technical specification, has been prepared by IEC technical committee 115: High-voltage direct current (HVDC) transmission for d.c. voltages above 100 kV.

This technical specification cancels and replaces IEC/PAS 62344 published in 2007. This first edition constitutes a technical revision.

The text of this technical specification is based on the following documents:

Enquiry draft	Report on voting
115/53/DTS	115/64/RVC

Full information on the voting for the approval of this technical specification can be found in the report on voting indicated in the above table.

This publication has been drafted in accordance with the ISO/IEC Directives, Part 2.

The committee has decided that the contents of this publication will remain unchanged until the stability date indicated on the IEC web site under "<http://webstore.iec.ch>" in the data related to the specific publication. At this date, the publication will be

- transformed into an International Standard,
- reconfirmed,
- withdrawn,
- replaced by a revised edition, or
- amended.

A bilingual version of this publication may be issued at a later date.

IMPORTANT – The 'colour inside' logo on the cover page of this publication indicates that it contains colours which are considered to be useful for the correct understanding of its contents. Users should therefore print this document using a colour printer.

INTRODUCTION

The high-voltage d.c. earth electrode is an important part of the d.c. power transmission system. It takes on the task of guiding the current into the earth under the monopolar metallic return operation mode, and the unbalanced current under the bipolar operation mode. Further, it secures and provides the reference potential of valve neutral point under the bipolar/ monopolar operation mode, to protect the safe operation of valves.

D.C. earth electrodes include land electrodes, sea electrodes, and shore electrodes. Today, there are around tens of d.c. electrodes in the world. Their influence on the nearby and far away environment is produced when there is d.c. current continuously leaking into the earth through d.c. earth electrodes.

Their influence on the surrounding environment includes:

- a) influence on humans, mainly due to step voltage, touch voltage and transferred voltage;
- b) influence on the electrode itself, mainly reflected by earth temperature rise and corrosion on the electrode;
- c) influence on nearby ponds and organisms in the sea;
- d) influence on the a.c. power system, mainly reflected by the d.c. voltage excursion of transformer neutral point;
- e) influence on buried metallic objects, mainly revealed by the corrosion on buried metallic pipelines, a.c. grounding grids, tower foundations for power transmission lines and armoured cables, etc.

For years, a great deal of experience has been accumulated in the research and design work in many countries, and relevant native standards or enterprise standards have been developed. The aim of this Technical Specification is to develop the design guide for d.c. earth electrodes, on the site selection, material selection, shape, buried depth, adoption of equipment and connection styles, etc. It could be referred to by the specialized employees in different countries, to ensure the safe operation of earth electrode under different modes, control the influence on the environment nearby and the environment far away to the acceptable level, and to reasonably decrease engineering costs.

To ensure this Technical Specification is more scientific, precise and practical, IEC/PAS 62344:2007 is referred to, and some research results obtained in recent years are adopted.

DESIGN OF EARTH ELECTRODE STATIONS FOR HIGH-VOLTAGE DIRECT CURRENT (HVDC) LINKS – GENERAL GUIDELINES

1 Scope

This Technical Specification applies to the design of earth electrode stations for high-voltage direct current (HVDC) links. It is intended to provide necessary guidelines, limits, and precautions to be followed during the design of earth electrodes to ensure safety of personnel and earth electrodes and prevent any significant impact they may exert on d.c. power transmission systems and the surrounding environment.

2 Normative references

The following documents, in whole or in part, are normatively referenced in this document and are indispensable for its application. For dated references, only the edition cited applies. For undated references, the latest edition of the referenced document (including any amendments) applies.

IEC/TS 60479-1, *Effects of current on human beings and livestock – Part 1: General aspects*

IEC/TS 61201, *Use of conventional touch voltage limits – Application guide*

IEC 61936-1, *Power installations exceeding 1 kV a.c. – Part 1: Common rules*

3 Terms and definitions

For the purposes of this document, the following terms and definitions apply.

3.1

earth electrode

ground electrode (US)

structure with a conductor or a group of conductors embedded in the soil or immersed in sea water, directly or surrounded with a specific conductive medium

EXAMPLE Coke, providing an electric connection to the earth, for transmission of d.c. current from a d.c. system.

[SOURCE: IEC 60050-195:1998, 195-02-01]

3.2

land electrode

earth electrode buried in the ground more than 1 km away from the coastline

3.3 shore electrode

3.3.1

beach electrode

electrode located on the beach inside the waterline (usually less than 1 km away from the waterline), and the active part of the electrode makes contact with the soil or with underground water, but not directly with seawater or pond electrodes

3.3.2**pond electrode**

electrode usually placed outside but within 100 m of the waterline, having electrodes directly in contact with sea water, within a small area which is usually protected against waves and possible ice damage by a breakwater

3.4**sea electrode**

electrode located away from the shoreline at a distance deeper than 100 m into the sea

3.5**electrode station**

whole system which guides current from electrode line to the earth or sea water, usually including, in addition to the electrode itself, the feeding cable, towers, switchgear and necessary auxiliary equipment

3.6**common earth electrode**

earth electrode system, which is composed of a single earth electrode or multiple earth electrodes in parallel, shared by multiple converter stations

Note 1 to entry: It mainly consists of earth electrodes and intertie lines between sub-earth electrodes in different electrode sites.

3.7**electrode site**

site where the earth electrode is located

3.8**electrode line**

overhead line or underground cable used to connect the neutral bus in a converter station to the earth electrode station

3.9**feeding rod**

earthing conductor buried underground or in the sea for guiding earthing current into the surrounding medium (soil or sea water)

Note 1 to entry: They are the most important devices in an earth electrode station.

3.10**feeding cable**

cable used to guide current from current-guiding wire to feeding rods

3.11**current-guiding wire**

main branch used to conduct current from electrode line (or bus) to feeding cables

3.12**current guiding system**

system used to guide the current from electrode line to feeding rods

Note 1 to entry: It consists of current-guiding wire(s), disconnecting switches, feeding cables and connections.

3.13**jumper cable**

cable used to connect two feeding rods placed at some distance from each other

EXAMPLE At two sides of a channel.

3.14

earth return operation mode

operation mode in the HVDC power transmission system, using d.c. lines and earth (or sea water) as the current loop

3.15

earth return system

series of devices designed and built specifically for earth return operation mode

Note 1 to entry: It mainly consists of the electrode line, earth electrode, current guiding system, and other auxiliary facilities.

3.16

rated current under monopolar mode

current of a converter station at rated power in monopolar (operation) mode

3.17

maximum overload current

maximum current for which the associated d.c. system(s) is designed for monopolar operation for longer than several minutes

3.18

maximum transient overcurrent

average maximum current flowing through the earth electrode for a few seconds when a system disturbance occurs

3.19

unbalanced current

difference of current between two poles during operation of a bipolar d.c. system

Note 1 to entry: For symmetrical bipolar operation mode, the unbalance current flowing can be controlled automatically by the control system within about 1% of the rated current.

Note 2 to entry: For asymmetrical bipolar operation mode, the current flowing through the earth electrode is the difference in currents between the two poles.

3.20

cathode

electrode capable of emitting negative charge carriers to and/or receiving positive charge carriers from the medium of lower conductivity

Note 1 to entry: The direction of electric current is from the medium of lower conductivity, through the cathode, to the external circuit.

Note 2 to entry: In some cases (e.g. electrochemical cells), the term "cathode" is applied to one or another electrode, depending on the electric operating condition of the device. In other cases (e.g. electronic tubes and semiconductor devices), the term "cathode" is assigned to a specific electrode.

[SOURCE: IEC 60050-151:2001, 151-13-03]

3.21

anode

electrode capable of emitting positive charge carriers to and/or receiving negative charge carriers from the medium of lower conductivity

Note 1 to entry: The direction of electric current is from the external circuit, through the anode, to the medium of lower conductivity.

Note 2 to entry: In some cases (e.g. electrochemical cells), the term "anode" is applied to one or another electrode, depending on the electric operating condition of the device. In other cases (e.g. electronic tubes and semiconductor devices), the term "anode" is assigned to a specific electrode.

[SOURCE: IEC 60050-151:2001, 151-13-02]

3.22 current-releasing density

3.22.1

current-releasing density per unit length

current released to earth from a unit length of feeding rod (in A/m)

3.22.2

current-releasing density per unit area

current released to earth from a unit area of coke surface (in A/m²)

3.23

designed lifespan

designed operational lifespan of the earth electrode, typically of the same order as the operational lifespan of the converter station

3.24

corrosion lifespan

time integral of current when a earth electrode runs as an anode, such as monopolar operation and bipolar operation with unbalanced current, during its designed lifespan, in the unit of ampere hour (Ah)

3.25

thermal time constant

time required for the temperature of the soil to reach the steady state temperature at the initial rate of rise of temperature

Note 1 to entry: In practice the soil temperature rises nonlinearly when earthing current is released into earth through an electrode, see Annex F.

3.26

earthing resistance

resistance between an earth electrode and earth at an infinite distance

3.27

step voltage

voltage between two points on the Earth's surface that are 1 m distant from each other, which is considered to be the stride length of a person

[SOURCE: IEC 60050-195:1998, 195-05-12]

3.28

touch voltage

potential difference between a grounded metallic structure and any point on the earth 1 m from the structure

3.29

transferred voltage

potential difference applied to a person when this person stands on the ground near the earth electrode and touches a conductor grounded at a remote site, or when this person stands on the ground far away from the earth electrode and touches a conductor grounded near the electrode site

3.30

insulated metallic structures

metallic structures buried in the ground near an earth electrode and coated with insulating material

3.31**bare metallic structures**

metallic structures buried in the ground near an earth electrode and not coated with insulating material

3.32**coefficient of uneven current distribution**

ratio of maximum current-releasing density at any specific point of an earth electrode, to the average current-releasing density of that earth electrode

Note 1 to entry: This parameter reflects the uniformity of current released from the earth electrode to the surrounding medium and is a dimensionless quantity.

3.33**equivalent earthing current**

ratio of time integral of current of an earth electrode operated as a cathode or anode to its designed lifespan

Note 1 to entry: It is used to analyze the corrosion impact on underground metallic objects in the vicinity of the electrode.

4 System conditions**4.1 General principles**

The system conditions to be considered during earth electrode design mainly include the amplitude and duration of the current relating to the earth electrode, and designed lifespan and polarity.

4.2 System parameters related to earth electrode design**4.2.1 Amplitude and duration of the current**

The operation current and duration of d.c. earth return operation systems should normally be specified in local regulations, bid documents, or specifications. In the absence of such documents that can be used as a reliable source, the following values may be used as a reference during design:

- a) the amplitude of earth electrode rated current is equal to the system rated current (I_N). The maximum duration of this current corresponds to that of the monopolar earth return operation mode of the earth electrode. For a bipolar system, the interval from the time when the monopolar system is put into service to the time when the bipolar system is put into service is typically used;
- b) the amplitude of the maximum overload current is typically 1,1~1,3 I_N . The maximum duration of this current is generally the time allowed for operation at maximum overload current after the cooling equipment is put into service;
- c) the amplitude of the maximum transient overcurrent is determined through system stability calculation, typically in the range of 1,25~1,5 I_N . The maximum duration is generally a few or less than 1 s;
- d) the amplitude of unbalanced current is the difference of the operating currents of two poles. For d.c. power transmission systems with two symmetrically operated poles, the value is very small relative to I_N , e.g. 1 % of I_N . The duration is the same as the bipolar operation time of the earth electrode.

4.2.2 Polarity

Polarity of the earth electrode shall comply with system operation and environment protection requirements. For anode type earth electrodes, the corrosion of earth electrode material shall be taken into account. In the presence of any long buried metallic structure near the earth electrode, corrosion at the far end of the metallic structure should also be taken into account.

For cathode type earth electrodes, the focus should be on the corrosion impact on buried metallic structures near the earth electrode. Should the cathode type earth electrode be a sea electrode, the impact of compound sediments near the earth electrode is also a concern. For earth electrodes with reversible polarity, in addition to the above issues relating to cathode and anode type earth electrodes, attention shall be paid to safe operation with reversible polarity. The earth electrodes for bipolar systems are often designed with reversible polarity.

4.2.3 Designed lifespan

The design of an earth electrode should generally allow construction and operation of associated converters in a series of steps. The designed lifespan shall be the same as that of the converter station using this earth electrode. Where no specific lifespan is specified, the minimum designed lifespan of an earth electrode should be 30 years or more.

Within the designed lifespan of an earth electrode, loss of earth electrode material caused by corrosion shall not affect its normal operation. During calculation of earth electrode corrosion lifespan, the following aspects shall be taken into account:

- a) monopolar system: for a monopolar system (or a bipolar system with one pole built and put into operation at an earlier stage), the polarity of the earth electrodes can be determined by the system planning studies. Where no specific requirements are stated, the design shall be based on the anode type of the earth electrode;
- b) bipolar system operated in monopolar mode: after a bipolar system is put into service, the situation where one pole is out of service for repair or maintenance and the other pole (healthy pole) is operated using earth as the circuit, shall be considered. To this end the ampere hours during operation as an anode shall be calculated based on data provided by the system planning studies;
- c) bipolar operation: during bipolar operation, the ampere hours of unbalanced current during operation as an anode shall be selected.

4.2.4 Common earth electrodes

For a common earth electrode(s) shared by multiple converter stations, the worst case which should be taken into account is where monopolar earth return operation mode occurs simultaneously at more than one converter station with the same polarity. Calculation of earthing current of the earth electrode(s) should consider the probability of superposition of currents from different converter stations. Usually, higher requests of electrode sites are demanded when common electrodes are under design.

The designed lifespan of a common earth electrode shall be determined as the interval from the time when the first converter station is put into operation to the time when the last converter station is put out of use.

The polarity of the common earth electrode is determined by summing the directions and amplitudes of the currents from all the converter stations that share it.

5 Design of land electrode stations

5.1 Main technical parameters

5.1.1 General principles

The design of the land electrode shall ensure its safe and reliable operation throughout its lifespan and under different earthing current conditions including rated current, maximum overload current, and maximum transient overcurrent. Different technical parameters such as temperature rise of the earth electrode, earthing resistance, step voltage, touch voltage and transferred voltage shall be controlled within the specified range by appropriate choices of electrode shape and buried depth. It is important to note that the change of electrode shape

or burial depth does not affect the electric field strength further than 1 km to 2 km away from the electrode.

For a common earth electrode(s) or multiple earth electrodes within a short distance of each other, the situation of long time simultaneous and continuous operation of d.c. systems with the same polarity under earth return operation mode shall be avoided as much as possible. In addition, the effect of one circuit operated in monopolar earth return mode on the neutral voltage shift of other bipolar systems should be considered.

Calculation of characteristics of earth electrodes shall be performed with programs. See Annex E for the calculation principles.

5.1.2 Temperature rise

Under all circumstances, the maximum temperature of any point of the earth electrode shall be lower than the boiling point of water at the local altitude. For example, at an elevation of 0 m, the maximum allowed temperature is 100 °C. The temperature rise calculation method is listed in Annex F.

5.1.3 Earthing resistance

The determination of earthing resistance for the electrode shall consider two aspects:

- a) the temperature rise of soil;
- b) touch and step voltage rise locally at the electrode station.

For an earth electrode in any operation mode which gives a large earthing current, if the duration of the current is longer than the thermal time constant of the electrode (see Annex F for the calculation method), which is typically the case for rated current, which flows into the earth for a long time, the maximum permissible earthing resistance is typically dependent on the permissible temperature rise, which should be in accordance with Formula (1):

$$R_e \leq \frac{1}{I_d} \sqrt{2\lambda_m \frac{\rho_e^2}{\rho_m} (\theta_{\max} - \theta_c)} \quad (1)$$

where

- R_e is the earthing resistance between the earth electrode and earth at an infinite distance (Ω);
- I_d is the a certain earthing current which flows into the earth for a long time (A);
- λ_m is the thermal conductivity of the soil where the earth electrode is buried (W/(m·°C));
- θ_{\max} is the maximum allowed soil temperature (°C);
- θ_c is the maximum natural temperature of soil (°C);
- ρ_m is the resistivity of the soil where the earth electrode is buried ($\Omega \cdot m$);
- ρ_e is the general equivalent earth resistivity at the electrode site ($\Omega \cdot m$, see B.2.6 for the calculation method).

If the duration of the current is shorter than the thermal time constant of the electrode, a higher resistance of earth electrode than that determined by Formula (1) can be allowed from the point of view of soil heating, see Formula (2). It is also acceptable that the minimum side length of coke section is used to control the soil temperature rise instead of earth resistance, see Formula (10).

$$R_{e\max} \leq \frac{1}{I_d} \sqrt{2\lambda \frac{\rho_e^2}{\rho_m} \text{dfac}(\theta_{\max} - \theta_c)} \quad (2)$$

where

dfac is the heat dissipation factor, typically in the range 5~10. In the absence of an accurate value, 5 is recommended.

5.1.4 Step voltage

The step voltage of any ground point that can be accessed by the public shall not exceed the safety limits defined for humans and livestock. According to tests conducted on 1 028 subjects, over 95 % of the subjects have a human body resistance greater than 1 400 Ω , and over 95 % of the subjects have no strong feeling at a d.c. current of 5,3 mA. Based on these test results and in consideration of different amplitudes and durations of d.c. system earthing currents, the maximum allowed step voltage of any point on the ground can be determined with Formula (3) under maximum overload current of one pole.

$$E_{sp} = 7,42 + 0,0318 \rho_s \quad (3)$$

where

E_{sp} is the permissible step voltage (V);

ρ_s is the resistivity of surface soil ($\Omega \cdot m$).

During contingency conditions, such as maintenance of the earth electrodes (1/8 or more parts of earth electrodes are out of service), according to IEC 61201 and IEC 60479-1, the maximum permissible step voltage (E_{sp}) shall be less than 70 V.

For common earth electrodes or multiple earth electrodes with a short distance, to lower the step voltage, the situation where two d.c. systems run simultaneously with the same polarity under earth return operation mode shall be avoided as much as possible. However, the case of these systems running in short-time (e.g. < 30 min) earth return operation mode with the same polarity due to accidents (e.g. equipment failures or human errors or lightning strikes, etc.) should be considered during design. Considering that it is small probability, the maximum allowed ground step voltage for common earth electrodes can be increased appropriately with reference to Formula (3) in this case, on the premise that the secondary impacts have been evaluated and the maximum permissible step voltage is lower than that in contingency conditions.

If any point on the ground fails to meet the above requirement for maximum step voltage, mitigation measures shall be taken.

5.1.5 Touch voltage

For earthed metallic structures that can be accessed by the public, the touch voltage of any point on the site ground shall not exceed E_{tp} obtained from Equation (4) under maximum overload current of one pole.

$$E_{tp} = 7,42 + 0,0159 \rho_s \quad (4)$$

where

E_{tp} is the permissible touch voltage (V).

For earthed metallic structures that cannot be accessed by the public, the maximum permissible touch voltage of any point on the site ground should be less than 70 V in general.

5.1.6 Current density

For land electrodes that are likely to run as anodes for a long time, the current density at the contact between coke and soil should be limited to prevent electro-osmosis (moving of water by the electric field). For anode-type earth electrodes that run in monopolar mode for a long

time and are in fine particle (clay) soil, the permissible average current density at the surface of coke and soil should be 0,5 A/m² to 1 A/m² at the rated current of one pole. For specified outage conditions (e.g. 30 % electrodes out of service), the current density may be higher as allowed by soil conditions.

For earth electrodes that run in bipolar mode for long periods or are in soil with high water content, an average current density of 2 A/m² or higher may be the permissible value under rated current of one pole.

5.1.7 Field intensity in fish ponds

For earth electrodes near fish ponds, the field intensity of any point in the water should not exceed 15 V/m when operating at rated current.

For common earth electrodes or multiple earth electrodes within a short distance of each other, the case of systems running in short-time (e.g. < 30 min) earth return operation mode with the same polarity should be considered during design.

5.2 Electrode site selection and parameter measurement

5.2.1 General principles

Selection of the electrode site is a critical step during earth electrode design, and also a complicated process, during which technical and economic comparison is required to select a safe, reliable, economically feasible, and environment-friendly site.

Local environmental impacts (see Clause 4) and remote environmental impacts (see Clause 7) should be focused on during selection of the electrode site. Survey, measurement, and calculations are all necessary in this step. To reduce the impact of earth current on the environment, sea or shore electrodes should be considered first if possible. The common earth electrode solution can be adopted as a priority if system operation conditions are met. Split earth electrodes or compact earth electrodes can be used if the technical and economic feasibility has been demonstrated.

5.2.2 Data collection survey

To find a suitable electrode site, a survey within a radius of at least 10 km should be conducted to obtain the natural conditions in the neighbourhood of the electrode site, which should at least include the landform and terrain, geological structure, hydrological-meteorological conditions, and ocean tide (for shore electrodes or sea electrodes), and a technical assessment should be carried out based on Annex B.

In addition, local development plans should be acquired from the local government or other relevant authority. For complete assessment of the electrode site under investigation, such information should at least cover existing and planned power facilities (such as substations and lines), buried metal pipes, armoured or earthed cables, and railway lines.

It is recommended that the collection information about extra high-voltage a.c. power facilities should cover a larger range, e.g. within 50 km of the electrode site.

5.2.3 Distance from converter station (substation)

During the determination of the electrode site, the impact of the earth electrodes on surrounding converter stations and a.c. substations shall be calculated. See Annex I for the calculation method. If calculation and analysis are not possible, the distance from the electrode site to any converter station or 220 kV or higher-voltage a.c. substation should be no less than 10 km in general to decrease the d.c. current into the a.c. transformers, and the minimum distance from the electrode site to any aerial power line with earth wire should be greater than 5 km to decrease the corrosion of tower grounding devices. If for some reason it

is impossible to keep outside these distances, measures should be taken to mitigate the effect, such as d.c. current-blocking devices in series with transformer neutral and ground (see Clause 7), or insulation between earth wires and the towers.

5.2.4 Environment conditions

The electrode site should be placed far away from cities and densely populated towns and be located without risk of flood erosion or long-time flood submersion. In addition, the location should be in an open space to facilitate making the necessary connections.

5.2.5 Terrain and landform

The electrode site shall provide a wide and conductive current-releasing area. In particular, the resistivity of the soil around the electrode site is preferably less than 100 $\Omega \cdot m$. The soil should be damp but without any water-logging.

5.2.6 Measurement of soil parameters

During the design of earth electrodes, the main physical parameters of the soil on the electrode site including the soil resistivity model, soil thermal conductivity, thermal capacity, maximum environmental temperature, humidity, and ground water table (see Annex B for detailed measurement methods and technical requirements) should be measured.

5.2.7 Geological exploration

For one to two predetermined electrode sites, the drilling method is used to explore the soil type and cover layer thickness on the electrode site. The exploration should be carried out in a range not less than the size of the earth electrode and up to the depth of the bedrock, if it is not too deep.

5.2.8 Topographical map

1:1 000 or 1:2 000 topographic maps should be drawn based on measurement results. The measurement range should be defined in such a way to ensure optimal layout of earth electrodes.

5.2.9 Values selected during design

In general, reasonable values shall be selected for soil parameters based on actual measurements through analysis, calculation and sorting:

- the reliability of the measurements should be higher than 95 %. For N effective values measured at the same place (X_1, X_2, \dots, X_N), the average (X_p) and standard deviation (σ) can be calculated with

$$X_p = \frac{1}{N} \sum_1^N X_n \quad (5)$$

$$\sigma = \sqrt{\frac{1}{N} \sum_1^N (X_n - X_p)^2} \quad (6)$$

The value of soil parameters can be calculated with:

$$X = X_p + 1,96 \cdot k \cdot \sigma \quad (7)$$

where $k = +1$ for soil resistivity and temperature, and $k = -1$ for thermal conductivity and thermal capacity;

- in case of uneven distribution of a soil parameter on the electrode site, the electrode site calculation model can be simplified appropriately on an equivalent basis for convenient calculation, but the characteristic parameters such as earth electrode current-releasing density, maximum temperature, maximum step voltage, earthing resistance, potential rise and its distribution shall not be significantly affected. As a general rule, a layered 2D horizontal site model can be used if the electrode site lies in a plain area, and a 3D site model could be more precise if the site lies in an area with complex terrain such as mountain, coast or river;
- values selected for soil resistivity during the design should consider the influence of unfavourable seasons, which means the season coefficient should be applied after calculation with Formula (7).

5.3 Earth electrode and associated components

5.3.1 General principles for material selection

Feeding rod material should be selected through technical and economical comparisons based on engineering and market conditions. The selection shall respect the following principles: good conductive property, good resistance to erosion, easy mechanical processing, no toxic or negative effect, and cost-effectiveness.

5.3.2 Selection of feeding rods and characteristics

Feeding rods used for d.c. earth electrodes should be preferably made of iron, high-silicon cast iron, high-silicon chromium iron, or graphite.

If the pH value of soil and ground water is between 3 and 11 and the content of $\text{Cl}^- + \text{SO}_4^{2-}$ ions is less than 500 mg/l, for anode type land electrodes with a service life shorter than 40×10^6 Ah, the feeding rods should be made of iron.

If the corrosion lifespan of the electrodes is longer than 40×10^6 Ah or the soil has a pH value less than 3, the feeding rods should be high-silicon cast (chromium) iron or graphite.

If high-silicon cast iron or high-silicon chromium iron is used for feeding rods, the final products should be equipped with feeding cable.

The carbon content in iron should be less than 0,5 %. Graphite should preferably be treated by submersion in linseed oil. The chemical composition of high-silicon cast iron and high-silicon chromium iron should correspond to the values listed in Table 1.

Table 1 – Composition of iron-silicon alloy electrode

Chemical composition	High-silicon cast iron (%)	High-silicon chromium iron (%)
Silicon (Si)	14,25~15,25	14,25~15,25
Manganese (Mn)	<0,5	≤0,5
Carbon (C)	<1,4	<1,4
Phosphorous (P)	<0,25	<0,25
Sulfur (S)	<0,1	<0,1
Chromium (Cr)	0	4~5
Iron (Fe)	>82,5	>77,5

5.3.3 Chemical and physical properties of petroleum coke

The chemical composition of the petroleum coke after calcination should correspond to the values listed in Table 2.

Table 2 – Chemical composition of the coke after calcination

Substance	Proportion (%)
Carbon	≥95
Water	≤0,1
Volatile components	≤0,5
Sulfur	≤1
Iron	≤0,04
Silicon	≤0,06
Ash and others	≤1

The physical properties of petroleum coke products used for d.c. earth electrodes should correspond to the values listed in Table 3.

Table 3 – Physical properties of petroleum coke used for earth electrodes

Properties	Values
Resistivity (at a volume weight of 1,1 g/cm ³)	<0,3 m
Volume weight	0,9~1,1 g/cm ³
Specific gravity	2 g/cm ³
Space ratio	45 %~55 %
Thermal capacity	>1,0 J/(cm ³ °C)

5.3.4 Current-guiding system

The earth current should be guided from electrode line to the current-guiding wire, disconnecting switchgear, feeding cables and connections in turn before it reaches different feeding rods (more details in 5.6).

5.3.5 Bus

The current is shunted by the bus, which can be of either the strain or rigid types. Strain bus is typically composed of an aluminium clad steel reinforced aluminium conductor, and rigid bus is typically composed of aluminium pipe.

5.3.6 Electrode line monitoring device

In some systems, electrode line monitoring (capacitor/reactor) devices are connected at the electrode end of the electrode line, to monitor the electrode line. The technical requirements of such devices are typically determined during converter station design. Their arrangement shall be considered during the design of the current guiding system.

5.4 Electrode arrangement

5.4.1 General principles

The arrangement of land electrode feeding rods can be classified as horizontal (trench) and vertical (well) type, which shall be selected through technical and economic comparison based on distribution of soil resistivity and terrain conditions. Generally, if the resistivity of deep soil (deeper than 10 m below ground) is significantly lower than that of the surface or if the ground water table is deep, a vertical well arrangement should preferably be used, otherwise horizontal trench arrangement should preferably be used.

5.4.2 Filling coke

Horizontal earth electrodes should preferably use square or rectangular sections or other suitable shapes according to the surrounding situation, and vertical earth electrodes should use circular sections. The feeding rod in the center is surrounded by filling coke, as shown in Figure 1. The recommended density of the reinforced filling coke should be between 1 000 kg/m³ and 1 100 kg/m³. The density for vertical electrodes should be higher in the case of water-filled bore holes.

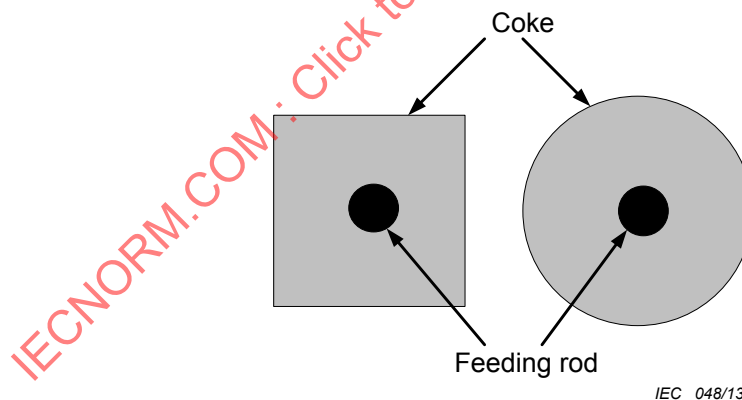

Figure 1 – Electrode cross-section

5.4.3 Selection of earth electrode shape

Selection of the shape of earth electrodes should respect the following rules:

- a) the distribution of current-releasing density shall be as uniform as possible;
- b) the average coefficient of uneven current distribution should be less than 10 %;
- c) the maximum coefficient of uneven current distribution should be less than 100 %.

To this end, the following principles should be kept in mind during the selection or determination of the shape of the land electrodes:

- if the site allows, first choose a single circular arrangement. If this proves to be unsuitable, next choose a double concentric circular arrangement, with the ratio of diameters of internal circle to external circle be between 0,7 and 0,85. If circular earth electrodes are not possible due to limited site conditions, the electrode arrangement should be as circular as possible, maximising the curvature radius at curved parts;
- in case of rough terrain (such as ravine or loch), star shape or linear arrangement should be used. In this case, the number of branches is generally no higher than 6, and a properly sized current-sharing loop should be installed at the end (often with the highest current-releasing density) to reduce current-releasing density at the end;
- if the temperature rise and step voltage or current density are critical factors, the concentric arrangement with multiple circles should be used, but the number of concentric circles should not exceed 3;
- symmetric arrangement should be adopted as much as possible to facilitate the layout of the current guiding system, improve current shunt uniformity and reliability of the current guiding system, and reduce construction cost of the current guiding system.

5.4.4 Earth electrode corridor (right of way)

If earth electrodes lie near any low-lying areas such as a trench, ditch or pond, and the burial depth of the earth electrodes is less than that of the trench, ditch or pond, the distance from the earth electrodes to its edge should generally be no less than 10 m.

5.4.5 Distance between sub-electrodes in the arrangement

In case of vertical arrangement of the earth electrode feeding rods, the distance between sub-electrodes should generally comply with Formula (8).

$$D \leq \eta L \quad (8)$$

where

- D is the distance between sub-electrodes in vertical arrangement (m);
- L is the length of the sub-electrodes in vertical arrangement (m);
- η is the coefficient, 0,8~1,0.

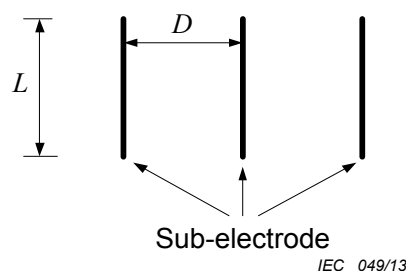

Figure 2 – Vertical arrangement

If earth electrode feeding rods are horizontally arranged in a discrete way, as shown in Figure 4 b) sub-electrodes should have a distances less than 2 m to achieve a uniform current distribution.

5.4.6 Burial depth of the earth electrodes

Optimal burial depth of earth electrodes should be selected through technical and economic comparison based on the following principles:

- step voltage control. If the electrode length is horizontally arranged, and the soil resistivity is uniform, the minimum burial depth of the earth electrodes can be calculated with Formula (9) approximately.

$$h = \frac{\rho_s \tau}{2\pi E_{sp}} \quad (9)$$

where

h is the minimum burial depth of the earth electrode (m);

ρ_s is the resistivity of soil ($\Omega \cdot m$);

τ is the earth electrode current-releasing density, calculated with earthing current divided by total length of electrode (A/m);

E_{sp} is the maximum permissible step voltage (V/m);

- b) the earth electrode should be buried in soil with low resistivity, good thermal performance, and high moisture, and shall not be buried in rock, sand and gravel layers, or dry soil with high resistivity;
- c) after the above conditions have been satisfied, the burial depth of the earth electrode should be minimized to reduce earthwork;
- d) the earth electrodes shall not be buried at a shallow depth to avoid artificial damage due to farming and machine-aided cultivation and impact of atmospheric temperature on the operation performance of electrodes. In general, earth electrodes should be buried to a depth exceeding 1,5 m.

5.4.7 Segmentation of earth electrodes

D.C. earth electrode feeding rods shall be divided into segments for better inspection and maintenance. The number of feeding rod segments shall be limited to avoid impact on current distribution and prevent a complicated current guiding system. Sub-electrode length shall be selected in such a way that other segments can still run safely and reliably at the specified maximum earthing current when one of these segments is put out of use (for maintenance).

5.5 Minimum size of earth electrode

5.5.1 General principles

Minimum sizes of earth electrodes refer to total earth electrode length, the side length of the coke section and the feeding rod diameter when the thermal stability or step voltage conditions are met. The principles for determining these three important dimensions include at least the following:

- at constant rated current, the highest temperature at any part of the earth electrodes shall not exceed the boiling point of water;
- at the maximum overload current, the maximum step voltage at any point on the ground shall not exceed the allowed value;
- during the designed lifespan, the feeding rods shall meet current-carrying requirements after the corrosion is considered.

5.5.2 Total earth electrode length

In general, the length of the earth electrode (or floor area) should be determined based on heating conditions (see 5.1.2 and 5.1.3), checked against the value allowed by maximum step voltage (see 5.1.4) and current density at the surface of the coke column (see 5.1.6), and finalized through optimization of the earth electrode material consumption.

5.5.3 Side length of coke section

For earth electrodes running in earth return mode, if the thermal time constant is greater than the duration of the rated current, the side length of the coke section at any point (P) of the electrode may be conservatively calculated by Formula (10) to ensure that the highest temperature at any point (P) will not exceed the permissible value.

$$S_p \geq k \cdot \rho_m \cdot \tau_p \sqrt{\frac{T_0}{16\rho_p C_p (\theta_{mp} - \theta_c)}} \quad (10)$$

where

- S_p is the side length of coke section at point P (m);
- k is the matching coefficient, in the range of 0,9~1,1; See Annex F.
- τ_p is the current-releasing density at point P (A/m);
- ρ_p is the soil resistivity at point P ($\Omega \cdot m$);
- C_p is the soil thermal capacity at point P (J/(m³ °C));
- ρ_m is the resistivity of the soil burial layer ($\Omega \cdot m$);
- θ_c is the highest natural temperature of the soil (°C);
- θ_{mp} is the maximum permitted temperature of the earth electrode (°C);
- T_0 is the duration of the rated current (s).

For earth electrodes running in anode mode for a long time, the maximum current density at soil contact surface should meet the recommendations in 5.1.6.

5.5.4 Diameter of feeding rods

To ensure that the feeding rods have sufficient current-carrying capacity, expected lifespan and permitted temperature rise, the sizes of feeding rods should comply with both Formulae (11) and (12).

$$\Phi_p \geq \sqrt{\frac{4k_1 k_2 \rho_p \tau_p F V_f + \pi \phi^2 \rho_m g I_d \times 10^{-3}}{\pi \rho_m g I_d \times 10^{-3}}} \quad (11)$$

$$\Phi_p \geq \frac{4S_p \rho_p C_p}{\pi \rho_p C} \times 10^3 \quad (12)$$

where

- S_p is the side length of coke section at point P (m), see Formula (10);
- Φ_p is the equivalent diameter of the feeding rod at point P (mm);
- k_1 is the protection coefficient, which is ratio of unit area ion current in the coke to the total current, $k_1 = 0,1 \sim 0,6$.
- k_2 is the electric corrosion accumulation effect coefficient, see Table 4 below.
- F is the service life of the anode (A·h);
- V_f is the electric corrosion rate of feeding rod material in the soil (kg/(A·h)), see Table 4;
- ϕ is the remaining equivalent diameter of the feeding rod when the total operation time of the earth electrode reaches the designed lifespan (mm);
- g is the specific density of the feeding rod material (g/cm³), see Table 4;
- ρ_c is the coke resistivity ($\Omega \cdot m$);
- C is the coke thermal capacity (J/(m³·°C));
- I_d is the rated current (A).

Others are the same as Formula (10).

Table 4 – Electric corrosion characteristics of different materials

Material	Specific density, g/cm^3	Corrosion rate, V_f (kg/(A·h))	Accumulation effect coefficient, k_2
Iron (steel)	7,86	0,001 039	3,0
High-silicon cast iron	7,03	0,000 228	2,0/3,0 (in sea water)
High-silicon chromium iron	7,02	0,000 114	2,0
Graphite	2,1	0,000 114	>3,0

5.6 Current guiding system

5.6.1 General principles

Generally, electrode lines from converter stations should first (or via electrode line monitoring reactors) be connected to the bus, and then the current should be guided to the current-guiding wire, disconnecting switchgear, feeding cables and connections in turn before it reaches different feeding rods. The current guiding system should be designed in such a way that the current flowing through branches of the same level is equal or roughly equal.

5.6.2 Placement of the current-guiding wire

The current-guiding wire can be overhead wire or underground cable. The placement of such wire should generally match the electrode shape to achieve good current sharing characteristics. In general, for symmetrically arranged earth electrodes, the current-guiding wire should also be arranged symmetrically, e.g. Figures 3a) or 3b).

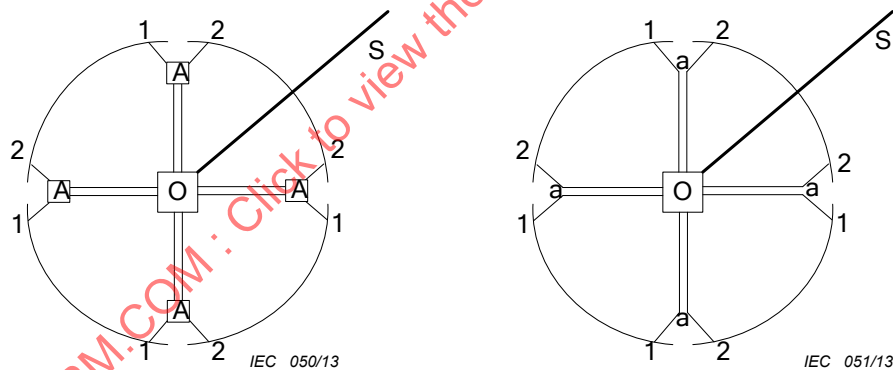

a) Overhead conductor is adopted b) Underground cable is adopted

Key

- O central tower
- A branch tower
- a location where the feeding cables branch.
- S-O electrode line
- A-O current-guiding wire (where overhead conductors are used) between central tower and branch tower.
- a-O current-guiding wire (where underground cables are used) between central tower and electrode.
- a-1, a-2 feeding cables
- A-1, A-2 feeding cables

Figure 3 – Placement of the current-guiding wire

5.6.3 Connection of current-guiding wire

To facilitate maintenance or commissioning, the current-guiding wire and feeding cable shall be bolted on the ground or connected with outdoor disconnecting switch, as per IEC 61936-1.

If a disconnecting switch is adopted, the disconnecting switches should be installed on the current-guiding wire support structures. To ensure human safety, disconnecting switches shall be fenced off or placed at a sufficient distance above ground.

5.6.4 Selection of current-guiding wire cross-section

The current-guiding wire cross-section should be selected based on the calculation results of the current in different branches, and in such a way that safe operation of other current-guiding wires is not affected under any earthing current operation conditions or when any electrode segment is out of use (due to damage or for the purpose of maintenance).

If cable is used as current-guiding wire, see 5.6.10.

5.6.5 Insulation of the current-guiding wire

Because the operation voltage on the earth electrode bus is very low (typically no higher than 10 kV even under transient conditions), the operation voltage on the bus is generally not a factor controlling the insulation level of the current-guiding wire.

If the current-guiding wire uses overhead line, the possibility of short-circuited insulator discs should be considered. Usually insulator strings with lightning impulse withstand level of at least 125 kV or at least two fully-rated d.c. suspension insulators are used as the insulation between the conductors and tower structure.

If cable is used as current-guiding wire, see 5.6.11.

5.6.6 Disconnecting switch

To facilitate commissioning or maintenance, disconnecting switches should be installed in each group of sub-electrodes. The rated current of the disconnecting switches shall be no less than the maximum current that may occur in the corresponding circuit. The rated voltage should be no less than 10 kV.

5.6.7 Connection of the feeding cable

Each electrode segment shall be connected to feeding cables.

If the feeding rod is made of high-conductivity iron, a feeding rod can be connected to the current-guiding wire directly by one feeding cable, as shown in Figure 4a). If the feeding rod is made of poor-conductivity material such as high-silicon cast iron or high-silicon chromium iron, an individual feeding cable is used to connect each feeding rod and the main feeding cable, which connects the current-guiding wire, as shown in Figure 4b).

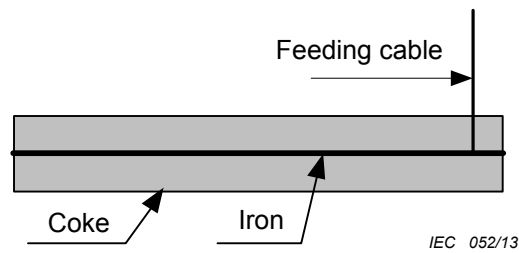

a) Iron used for feeding rod

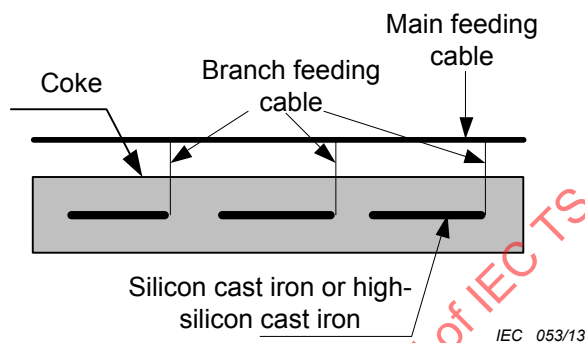

b) Silicon cast iron or high-silicon cast iron used for feeding rod

Figure 4 – Feeding cable

5.6.8 Connection of jumper cables

To reduce the step voltage, each sub-electrode shall be continuous as much as possible. The electrode may be disconnected if it has to cross low-lying areas such as trenches, ponds, or ditches, provided the electrical connections between the two segments are ensured. Two jumper cables are typically used to join disconnected electrode segments.

5.6.9 Selection of cable structure

Feeding cables and jumper cables should preferably use single core copper conductors with insulation, e.g. Kynar or XLPE, to facilitate construction, operation and maintenance and to reduce the cost. For cable buried directly in soil, single core copper conductor cable with double insulation may be used.

5.6.10 Selection of cable cross-section

For feeding cables and jumper cables (or cable-type current-guiding wire), the current-carrying cross-section shall be selected based on the calculation results of the current in different branches, and in such a way that safe operation of a cable is not affected under any earthing current operation conditions or when the other cable is out of use (due to damage or for the purpose of maintenance).

When selecting the cross-section of underground cable conductors, the maximum allowed current-carrying capacity of the cable shall be calibrated based on the environmental conditions of the soil (such as the parameters of maximum ambient temperature, soil thermal conductivity, thermal capacity, and cable distance). In addition, the insulation cover shall provide good thermal stability.

5.6.11 Selection of cable insulation

The insulation of current guiding system cables can be generally grouped into two levels:

- for feeding cable and jumper cable (or cable-type current-guiding wire), the insulation level should be generally no less than 6 kV and should preferably have a metal sheath to prevent moisture absorption into the cable;
- for branch feeding cables connected to high-silicon cast iron or high-silicon chromium iron sub-electrodes, the insulation level should be generally no less than 750 V and should preferably have double insulation.

5.6.12 Cable welding position

For a feeding rod made of iron (steel), during connection between feeding cable and feeding rod and between jumper cable and feeding rod, the recommended welding position should be more than 5 m away from ends of the electrode (feeding rod).

5.6.13 Welding

For connections and splices between underground cable and feeding rods, exothermic welding or arc welding should be used. Pressure welding or bolt connection is prohibited.

The welding shall be firm and tight. The welding contact resistance shall not exceed that of the material of the same length with original specifications.

5.6.14 Mechanical protection for cable

All underground cables shall be effectively protected. The cable should be fixed on a cable bracket and be protected by a properly sized PVC plastic pipe at the place where the feeding cable enters the ground. For current-guiding wires, feeding cables or jumper cables that are directly buried in soil, sand should be filled around them, with cement panels laid directly over the cable to protect it against damages caused by external forces. For branch feeding cables connected to high-silicon cast iron or high-silicon chromium iron sub-electrodes, compatible PVC plastic pipes should be used as shields.

All underground cable joints and welding points exposed to soil shall be sealed reliably with epoxy resin.

5.7 Auxiliary facilities

5.7.1 Online monitoring

To determine or monitor the operation status of earth electrodes, monitoring devices that can detect current distribution, temperature and humidity of the earth electrodes shall be installed at the location of the current-feeding cable. Alternatively installation shall be done in a manner such that portable instruments can be used. Common detection devices can be connected via detection wells. An online monitoring system can be set up if necessary. See Annex G for operation principle of this system. The current distribution detection device shall at least be able to detect current flowing through different feeding cables. The detection well or sensor should be preferably placed at the access point of the feeding cable where high current-releasing density or high temperature rise occurs.

A main and redundant power supply system which may include the combination of local a.c. supply, solar panel, batteries or diesel generator may be installed for the electrode monitoring and control.

5.7.2 Soil treatment

If required, water-filling devices should be installed for horizontal (trench) type earth electrodes to reduce soil resistivity and prevent soil from drying out. During design, suitable water filling methods such as seepage wells can be selected based on site conditions.

5.7.3 Exhaust equipment

To facilitate release of gas generated during operation of the earth electrodes and maintain good operation characteristics of the earth electrodes, earth electrodes, especially deep well type and shore type electrodes, are typically equipped with exhaust equipment.

5.7.4 Fence

If the step voltage or touch voltage exceeds safe limits, a wall or fence shall be erected, carrying distinguishing marks to prevent or warn unauthorized people attempting to enter the site.

The fence should be preferably made of insulating materials such as brick, wood. If non-insulating material is used, small independent earthing devices should be installed and the fence should be discontinuous.

5.7.5 Marker

A marker should be erected at a proper place right over the earth electrode if required.

6 Design of sea electrode station and shore electrode station

6.1 Main technical parameters

Design of the sea electrodes or the shore electrodes should ensure their safe and reliable operations throughout their life cycles and under different earthing current conditions including rated current, maximum overload current, and maximum transient overcurrent. Different technical parameters such as earthing resistance, voltage gradient in water, step voltage, touch voltage and transferred voltage should be within the specified range.

6.1.1 Temperature rise

The temperature rise is not a dimensioning factor for sea electrodes and pond electrodes, and is not required to do this calculation.

For beach electrode stations, the basic principle is that the maximum temperature of any point of the earth electrode shall be lower than the boiling point of water under all circumstances. The temperature calculation can be conducted by transformation of Formula (2), in which the value of λ will be about 2,5 W/m·°C for soil and seabed and d_{fac} may be 10 since the soil in the electrode area is saturated with water close to the surface.

6.1.2 Earthing resistance

Since the resistivity layers of sea and shore electrodes are not horizontal, the formula to calculate the resistance to remote earth is more complicated than for electrodes with horizontal layers (see Figure 5).

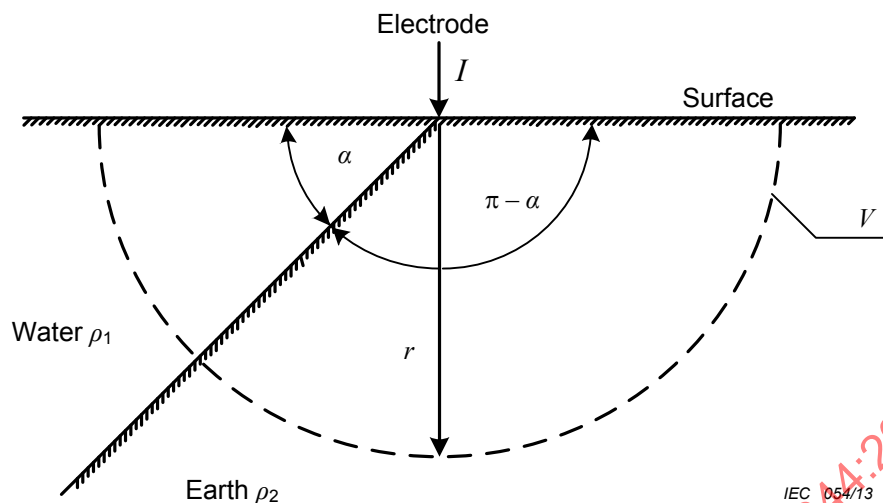

Figure 5 – Resistivity layers with sea or shore electrodes

The potential V of the equipotential sphere with radius r (m), for the parameters as defined in Figure 5 is given by Equation (13) for homogenous soil, and the earthing resistance can be obtained by V/I .

$$V = \frac{I}{2r \left(\frac{\alpha}{\rho_1} + \frac{\pi - \alpha}{\rho_2} \right)} \quad (13)$$

As the equipotentials are spheres, the potential varies as $1/r$, therefore an apparent resistivity ρ_α can be evaluated from the last equation simply by:

$$\rho_\alpha = \frac{\pi}{\left(\frac{\alpha}{\rho_1} + \frac{\pi - \alpha}{\rho_2} \right)} \quad (14)$$

And used with the formula for homogenous soil:

$$V = \frac{\rho_\alpha \cdot I}{2\pi r} \quad (15)$$

For the best results, calculation should be performed with computer programs.

6.1.3 Step voltage

The step voltage of any ground point shall not exceed the safety limits defined for humans and livestock (see 5.1.4).

Step voltages tend to be of a high level in beach stations, if the electrode is buried at a moderate depth. The fence will often be damaged if the station area is at risk of possible high tides, waves and/or ice. If it is preferred to avoid fencing, the total station shall be made larger, or buried at a greater depth.

6.1.4 Touch voltage

For earthed metallic structures that can be accessed by the public, the touch voltage of any point on the site ground shall not exceed the safety limits defined for humans under the maximum overload current of one pole (see 5.1.5).

6.1.5 Voltage gradient in water

The voltage gradient in water shall not exceed 1,25 V/m to 2 V/m in areas accessible to humans or marine fauna.

6.1.6 Current density

The recommended average current density in sea water for sea electrodes and pond electrodes is 6 A/m² to 10 A/m² in order to ensure a suitable gradient of 1,25 V/m to 2 V/m close to the electrode (at a sea water resistivity of 0,2 Ω·m). The anode should be shielded from fish, as fish are attracted to the anode and not the cathode. If the sea electrodes or pond electrodes are functioning in an environment open to free water but not accessible to human beings or to marine fauna, the average current density can be raised to a value up to 100 A/m².

For beach electrodes, in addition to electro-osmosis, Cl₂ generation should also be considered since it is not good for the electrode. For water saturated beach electrodes, the recommended current density on the surface of the coke is 7 A/m².

6.2 Electrode site selection and parameter measurement

6.2.1 General principles

Selection of the electrode site is a critical step during earth electrode design, and also a complicated process, during which technical and economic comparison is required to select a safe, reliable, economically feasible, and environment-friendly site.

The following factors shall be considered when candidate sea electrode sites are compared and selected: distance to converter station, substations, pipe lines, cables, etc., salinity of the sea water, slope of the sea bed, resistivity on the shore, and uniformity of the sea bed.

6.2.2 Data collection survey

To find a suitable electrode site, a survey within a radius of at least 10 km should be conducted to determine the natural conditions in the neighbourhood of the electrode site under investigation, which should at least include the landform and terrain, geological structure, ocean tide and currents in the sea. The survey shall show that the sea bed is without clay so that the electrode does not sink.

Coastal areas are often characterised by a layer of fresh water, rising to a higher level than the nearby sea and a deeper layer of salt water, penetrating from the sea. If a distinct interface between freshwater and saline water exists, survey should be done to determine which depth is the best for the active part of an electrode station. If the current is emitted in the fresh water layer, anodic operation will evolve only oxygen, not chlorine. If the electrode is close to, but still above, the interface, the salt-water layer will absorb the current very effectively, within a short horizontal distance. If low resistance to remote earth and decrease of loss are the goals, the electrodes shall be placed in the saline strata, but some evolution of chlorine will be the result.

6.2.3 Distance from converter station (substation)

During the determination of the electrode site and during the commissioning of the electrode station, the impact of earth electrodes on surrounding converter stations and a.c. substations shall be calculated or measured.

6.2.4 Environment conditions

The electrode site should be placed far away from populated areas, such as vacation beaches.

6.2.5 Measurement of soil parameters

The measurement of soil parameters shall meet the following requirements:

- a) the Wenner or Schlumberger methods may be used for earth resistivity surveys at shallow depths. The magnetotelluric (MT) method shall be used for areas with greater depths (see Annex B);
- b) the salinity of the sea-water shall be measured.

In electrolytic processes there will always be a chemical action, because the materials in the soil (more precisely the substances diluted in the ground/seawater) will be decomposed and/or built up to new chemical substances.

In an anodic process in ground water of very low or zero salinity, O₂ (oxygen) is produced and emanates, which is generally not seen as a problem since the atmosphere partly consists of O₂. With increasing salinity the evolution of Cl₂ (chlorine) will take over, but there will still be, even in salinities up to sea water level, a substantial evolution of O₂. The sum of evolved gases respects Faraday's law of electrolysis, which says that the mass of decomposed material is proportional to the electric charge, i.e. the number of ampere hours.

6.3 Earth electrode and associated components

6.3.1 General principles for material selection

The material shall be selected through technical and economical comparisons based on engineering and market conditions. The selection shall respect the following principles: low dissolution rate as well as low chlorine emission rate in anodic regime, low toxic or other negative effects, and cost-effectiveness.

6.3.2 Common feeding rods and characteristics

Feeding rods used for sea electrodes or shore electrodes should be preferably made of high-silicon chromium iron, or graphite embedded in coke. The carbon content in iron should be less than 0,5 %. Graphite should preferably be treated by submersion in linseed oil. The chemical composition of high-silicon chromium iron should correspond to the values listed in Table 1.

Other material that can be used directly in sea water without embedment in coke are:

- a) platinised titanium or niobium (Pt/Ti or Pt/Nb);
- b) magnetite;
- c) bare copper conductors (for cathodic operation only);
- d) mixed metal oxides (MMO).

Platinised titanium is also well-known (for anodes) and may also be used as the cathode, depending on the manufacturer. The material is as an expanded mesh of titanium, of which the filaments are about 0,5 mm × 2 mm, all interconnected in about 20 mm × 50 mm meshes. The titanium is covered by a special thin (5 µm -20 µm) layer of metals, resistant to anodic corrosion. The expanded network is delivered in subelectrodes each covering 1,22 m × 16,5 m.

Magnetite, Fe₃O₄, is commonly used for cathodic protection purposes. The electrodes are produced in rod-form, 0,06 m in diameter, 0,72 m in length and other sizes as well. The resistivity of magnetite is $5 \times 10^{-5} \Omega \cdot m$ – $10 \times 10^{-5} \Omega \cdot m$.

Copper is good choice for cathodic electrodes. A reason for this choice is the possibility of establishing reliable clamp connections by compression or by welding, which will withstand the environmental conditions of the sea-water.

6.3.3 Chemical properties of petroleum coke

See 5.3.3.

6.3.4 Current-guiding system

See 6.5.

6.3.5 Bus

See 5.3.5.

6.3.6 Electrode line monitoring device

See 5.3.6.

6.4 Electrode arrangement

6.4.1 General principles

The arrangement of sea electrode feeding rods can be classified as horizontal embedded in coke (see Figure 6 below) or placed in cages directly on the bottom of the sea. If nets are used, these shall be placed on sea bottom and covered by gravel or cement sacks.

The arrangement of shore electrode feeding rods can be classified as vertical embedded in coke (beach type) or placed directly in sea-water (pond type).

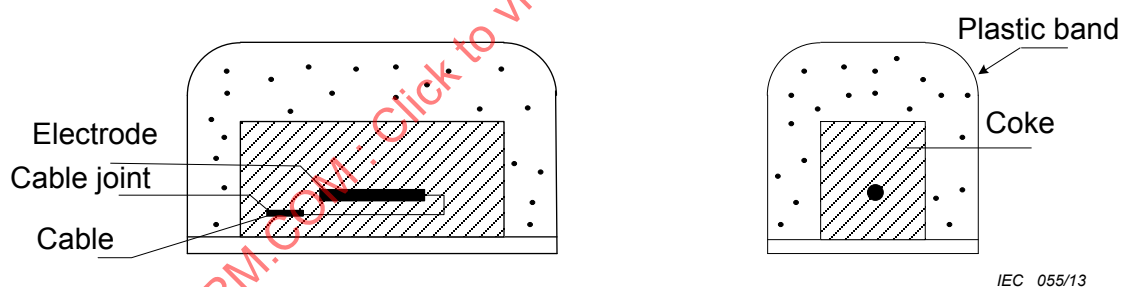

Figure 6 – Sea electrode

6.4.2 Filling coke

For sea electrodes and shore electrodes, the filling of coke, if used, should be performed on the shore. Fabric shall be used to keep the coke in place. The sub electrode is then placed on the sea bed, covered by gravel or cement sacks.

For beach electrodes, the sub electrode is then placed in the bore holes made on the shore.

6.4.3 Selection of earth electrode shape

The physical layout of the electrode should be as round as possible. With a net type electrode (anodes) the ends form a curve approximately to half circles against the coast. See Figure 7 below. This is to ensure the best possible current sharing among sub-electrodes, because the influence of current density on the production of Cl_2 makes it important that all sub-electrodes carry an equally low part of the current. For shore electrodes, if the shore is narrow, an elliptical shape electrode may be used.

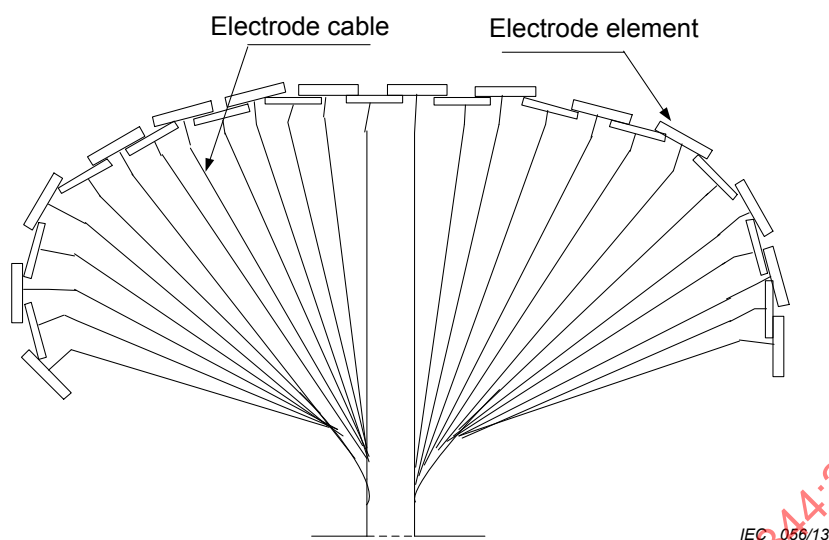

Figure 7 – Sea bottom electrode with titanium nets

6.4.4 Segmentation of earth electrodes

D.C. earth electrode sub sections shall be divided into a few segments for better inspection and maintenance. The number of sub sections shall be limited to avoid impact on current distribution and avoid the need for a complicated current guiding system. Subsections shall be performed so one part of the electrode can be taken out for maintenance or repair without resulting in unacceptably high potentials in water or ground close to the section out of service.

If the total electrode is composed of a number of sub-electrodes (which is preferred), then two different "philosophies" shall be considered:

- a) the sub-electrodes are placed such that they are easily accessible for inspection/repair. This normally requires a small depth of burial and generally applies only to horizontal sub-electrodes;
- b) the sub-electrodes are inaccessible when installed, with the idea that they are of a disposable (throwaway) type, which is left underground when damaged, if they are too difficult to salvage. A new substitution electrode is arranged close to the damaged one. This philosophy is relevant to vertical electrodes, buried at large depths.

6.5 Current-guiding system

6.5.1 Placement of the current-guiding wire

For sea electrodes and pond electrodes, the busbar and other equipment, should preferably be placed in a cabin at some distance (e.g. more than 500 m) from the electrode area, at a safe level above sea surface. The current guiding wires between the busbar in the cabin and the sub-electrodes, or subparts, shall preferably be made as individual smaller cables, or mutually insulated sub-conductors in large cables. The extra (and equal) resistance in each sub-conductor will tend to equalize the current sharing among sub-electrodes. If not, series resistors can be used.

For beach electrodes, see 5.6.2.

6.5.2 Connection of current-guiding system

For beach electrodes, see 5.6.3.

For sea electrodes and pond electrodes, each electrode segment shall be connected to feeding cables, and feeding cables shall be connected to current guiding wires (in cable-type), see Figure 8 below.

The cables to the electrode element shall be made by the manufacturer of the electrode element. The feeding cable shall have a watertight heat-shrink joint to the element.

All cables, connection points and joints intended for anodic operation shall be well insulated since a direct contact with the water results in heavy electrolytic corrosion. The insulation shall, in addition, resist high electrode temperatures, mechanical stress during installation and various aggressive chemical elements in the environment.

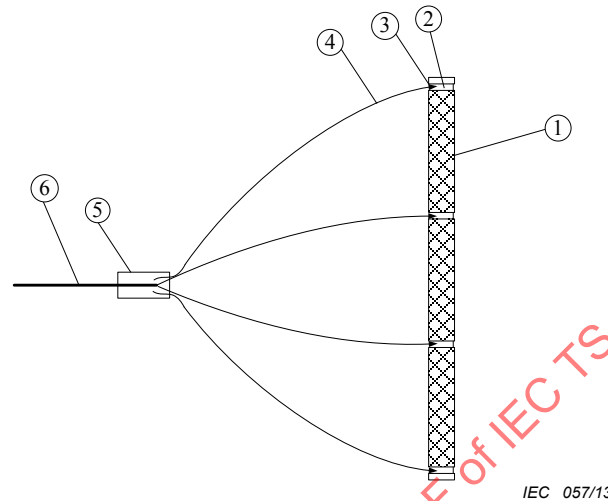

Key

- 1) Electrode of titanium net, 1,22 m × 16,5 m
- 2) Connection plate of titanium
- 3) Watertight heat-shrink joint
- 4) Electrode cable (feeding cable), Copper conductor 10 mm²
- 5) Watertight heat-shrink joint
- 6) Electrode cable (current guiding wire), copper 35 mm²

Figure 8 – Titanium net

6.5.3 Selection of cable cross-section

See 5.6.10.

6.5.4 Insulation of the current-guiding system

See 5.6.5 and 5.6.11.

6.5.5 Selection of cable structure

Feeding cable should preferably use single core copper conductor with insulation, e.g. Kynar or XLPE, to facilitate construction, operation and maintenance and to reduce the cost. For cable buried directly in the sea bed, single core copper conductor cable with double insulation may be used.

6.5.6 Mechanical protection for cable

See 5.6.14.

6.6 Auxiliary facilities

To determine or monitor operation status of earth electrodes, monitoring devices that can detect current distribution of the earth electrodes shall be installed at the location of current-feeding cables (see 5.7.1).

Exhaust equipment should be considered for exhaust of Cl₂ (see 5.7.3).

7 Impact on surrounding facilities and mitigation measures

7.1 Impact on insulated metallic structures and mitigation measures

7.1.1 General principles

Touch voltage on any insulated metal structure buried near earth electrodes caused by ground return current shall not affect safety and health of people in contact with the metal structure, and possible corrosion shall not affect normal operation of the structures.

7.1.2 Relevant limits

For underground metal pipes insulated by surrounding cement or asphalt, the voltage between the pipe and surrounding soil shall be within the range from –1,5 V to –0,85 V at the equivalent earthing current. If this is not the case, proper precautions should be taken.

For pipes equipped with a cathodic protection system, the voltage to earth on the pipes caused by earth electrode earthing current shall not exceed the capability of the cathodic protection system.

At normal rated current, the touch voltage of a metal structure shall not exceed 70 V. If this is not the case, proper precautions should be taken.

7.1.3 Mitigation measures

For insulated metal pipes buried in ground with a voltage exceeding the limit, common precautions include addition or reinforcement of cathodic protection capabilities, addition of pipe anti-corrosion coating, and separating a pipe into segments and connecting them with insulative materials.

7.2 Impact on bare metallic structures

7.2.1 General principles

Impact of current field of d.c. earthing current on any buried bare metallic structure, such as touch voltage and corrosion, shall not affect the normal behavior of people in contact with the metallic structure and safe normal operation of the metal structure.

7.2.2 Relevant limits

To protect personal safety, the touch voltage of any metal structure shall not exceed the value defined in 5.1.5. If this is not the case, proper precautions should be taken.

During analysis of corrosion effects of the earth electrodes on surrounding bare metallic structures, the current density at the surface of any buried metal structure exposed to soil should not exceed 1 μA/cm² at the equivalent earthing current, and the corrosion shall not affect normal operation of the metal structure. See Annex H for the calculation method.

7.2.3 Mitigation measures

The distance between earth electrodes and surrounding bare metal structures should be as large as possible. If the minimum distance between earth electrodes and underground bare metal structures, such as buried bare metallic pipes, is less than 10 km, or if the length of the underground metallic structure is longer than the distance, the adverse effects of d.c. earthing current of the earth electrodes on the structure shall be calculated.

In case of excessive current flowing out of a bare metal pipe exposed to soil, corresponding anti-corrosion measures shall be taken for the metal pipe. A commonly used precaution is an insulation coating or cathodic protection. The insulation coating is usually made of concrete, asphalt, enamel, or resin, and polyvinyl fluoride is the best choice. Cathodic protection is typically achieved in two ways: primary battery cathodic protection or external d.c. power supply cathodic protection.

7.3 Impact on the power system (power transformer, grounding network, and surrounding towers)

7.3.1 General principles

Rise of earth potential on an a.c. system near the earth electrodes resulting from the earthing current is likely to cause d.c. component in neutral-grounded transformers and consequently d.c. biasing. The schematic diagram of impact of the d.c. earth electrodes on a.c. systems is shown in Figure 9.

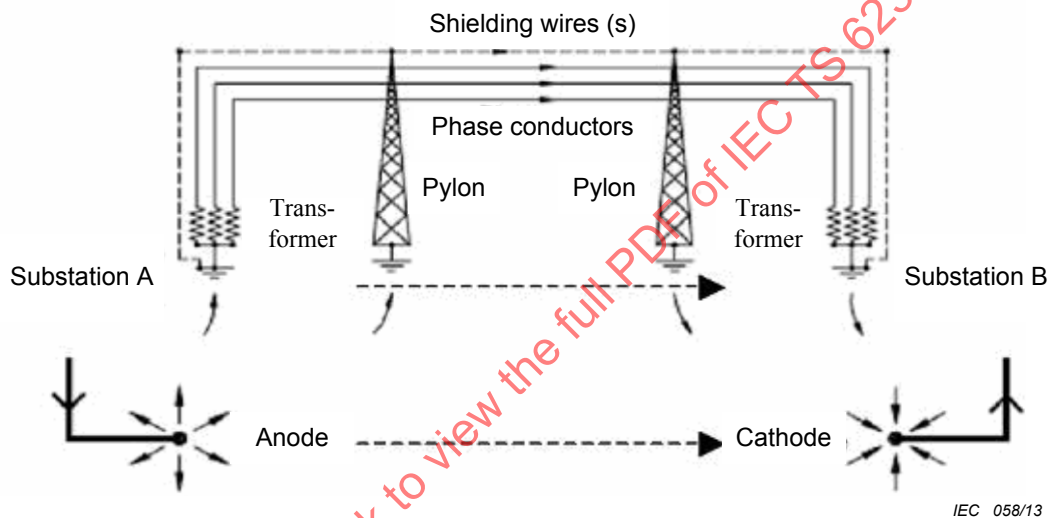

Figure 9 – Impact of earth electrodes on a.c. systems (transformer, grounding network, tower)

7.3.2 Relevant limits

The permissible d.c. current for windings of each transformer phase, if actual values are not known, can be as follows: 0,3 % of rated current for a single-phase transformer, 0,5 % of rated current for a three-phase five-legged transformer, or 0,7 % of rated current for a three-phase three-legged transformer.

7.3.3 Mitigation measures

If the earth electrode d.c. current flowing through the transformer windings is higher than the above limit, proper current-limiting or d.c. current-blocking measures shall be taken. The two main methods are:

- d.c. current-blocking capacitor;
- a small resistor connected in series with transformer neutral and ground.

7.4 Impact on electrified railway

If the earth electrodes lie near an electrified railway, simulative calculation should be performed to analyze issues concerning touch voltage on communication cables and signal cables of the railway caused by the earth electrode earthing current, d.c. current flowing through the traction transformer, and corrosion of earthing devices. Under rated current, the touch voltage between any point on the communication and signal cable and the common

machine control room should not exceed 70 V, the consequent corrosion of earthing devices shall not affect their normal operation, and the d.c. current flowing through the traction transformer in the traction station shall be within the allowed range (usually higher than those of general a.c. transformers).

7.5 Other facilities (such as greenhouses and water pipes)

If the earth electrodes lie near facilities such as greenhouse or earthed metallic water pipes, the touch voltage and transferred voltage generated on them shall be considered. Impact of the touch voltage and transferred voltage can be reduced by earthing or removal or relocation of these facilities.

If the earth electrodes lie near a seismic station, simulative calculation and measurement should be performed to evaluate the potential difference between observation electrodes and magnetic flux density caused by the electrode lines and d.c. transmission lines. Measures such as adjusting the direction or the length of the seismic station observation electrodes can be taken.

IECNORM.COM : Click to view the full PDF of IEC TS 62344:2013

Annex A (informative)

Basic concepts of earth electrodes

A.1 Basic concepts

Earth electrodes play a very important role in the operation of d.c. power transmission systems. Firstly, they can supply power to the system for a long time to improve system operation reliability. Secondly, they can hold the neutral potential at the converter station (rectifying valve) to avoid equipment damage due to unbalanced voltage to earth of the two poles. Hence the design of earth electrodes is very critical during the design and construction of the whole d.c. power transmission system.

A.2 Operation mode

A.2.1 General

An HVDC power transmission system typically consists of three parts: rectifier station, d.c. current line, and inverter station, as shown in Figure A.1.

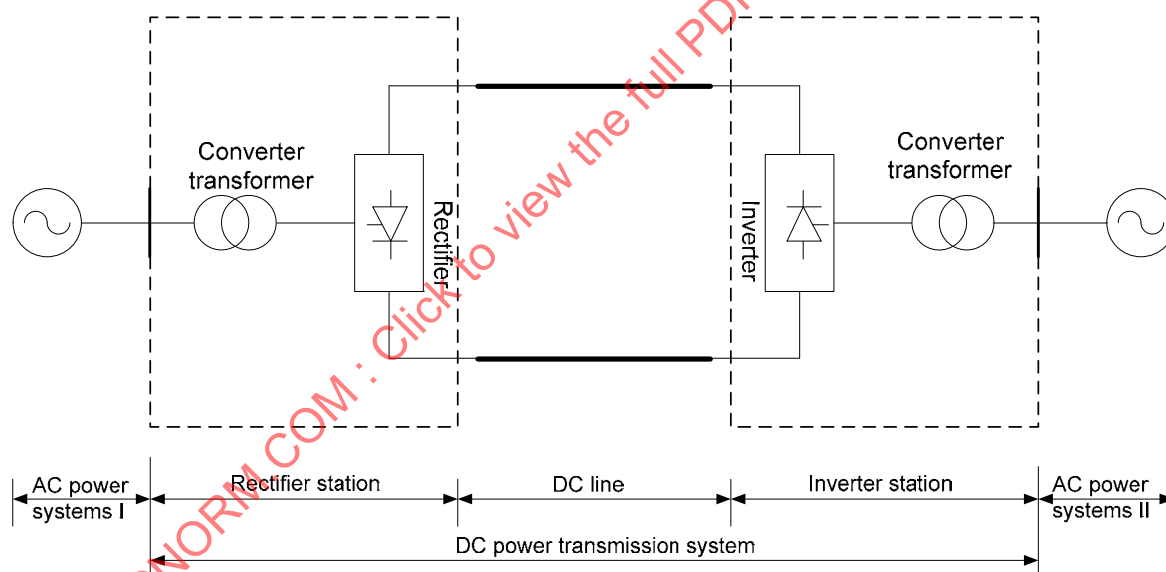

IEC 059/13

Figure A.1 – HVDC power transmission system structure

Depending on the number of nodes connected to a.c. systems, d.c. power transmission systems can be grouped into two-terminal and multiple-terminal systems. Two-terminal d.c. power transmission systems can be further classified into three types: monopolar type, bipolar type and back-to-back type.

A.2.2 Monopolar system

A.2.2.1 General

The monopolar system as shown in Figure A.2 is typically operated with the positive pole connected to earth. This type of d.c. system actually has only one negative pole, and due to this it is called a monopolar system. The advantage of a monopolar system operated in negative pole mode lies in the fact that it is less likely to be affected by lightning strikes and produces less radio disturbance caused by corona than the positive pole operation mode. The

monopolar systems can be further classified into single-pole earth (seawater) return mode and monopolar metallic return mode.

NOTE The terms “positive pole” and “negative pole” relate to the voltage polarity of that pole under the operating condition when power is being transmitted in the direction for which the HVDC project was primarily designed. For HVDC projects that are designed to be bi-directional, it is not possible to distinguish between the terms “positive pole” and “negative pole”.

A.2.2.2 Monopolar earth (sea water) return mode

This is a d.c. power transmission system with an overhead conductor or cable and using earth or sea water as the return circuit. It is also called a one-line one-earth system.

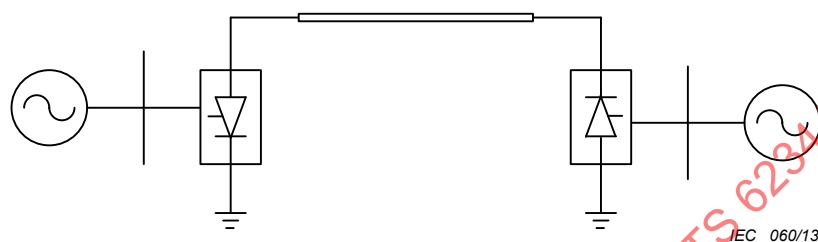

Figure A.2 – Schematic diagram of the structure of a monopolar earth (sea water) return system

A power transmission system adopting monopolar earth (sea water) return mode can save investment in lines. However, electrochemical corrosion may occur in underground metal facilities at places where the system passes by, and nearby communication and magnetic compass may be disturbed. This operation mode is applied in many systems, including the Gotland Island d.c. system in Sweden and the Sardinia-Corsica-Italy d.c. system.

A.2.2.3 Monopolar metallic return mode

This is also called a monopolar two-line system. It is a monopolar line system using a low insulation conductor earthed at one end as the return circuit, as shown in Figure A.3. It should be noted that the earth reference shown in Figure A.3 conducts no d.c. current and does not need to be designed as an earth electrode.

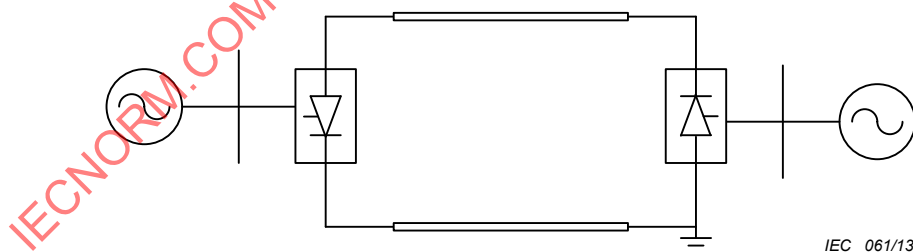

Figure A.3 – Schematic diagram of the structure of monopolar metallic return system

A.2.3 Bipolar system

A.2.3.1 General

As shown in Figure A.4, the bipolar line mode requires two conductors of different polarities (positive and negative pole). Bipolar systems can be further classified into three types: bipolar neutral grounded at both ends, bipolar neutral grounded at one end, and bipolar neutral line.

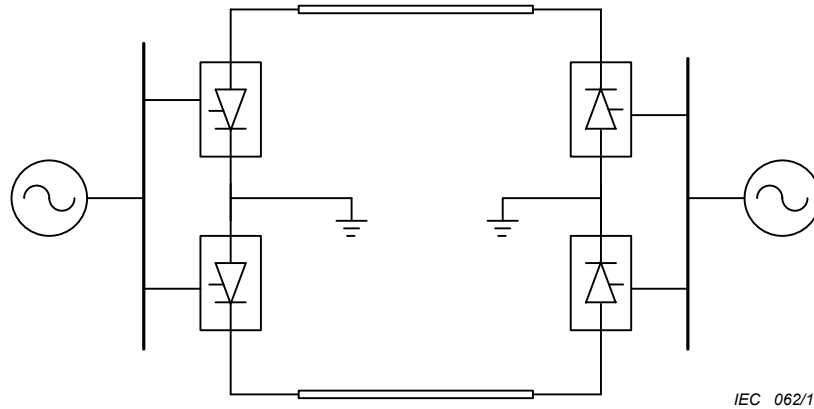

Figure A.4 – Schematic diagram of the structure of bipolar neutral grounded at both ends

A.2.3.2 Bipolar neutral grounded at both ends

The mode of bipolar neutral grounded at both ends is shown in Figure A.4. Both the neutral of the rectifier station and that of the inverter station are grounded in this mode. It can be regarded as a system formed by two superimposed one-line one-ground monopolar systems. Unbalanced current flows through the return circuit during normal operation. If this current is low (e.g. symmetrically operated bipolar system), corrosion on underground metallic equipment is significantly reduced. Besides, in case of failure of any pole, the functional pole can still use earth or sea water as the current return circuit and thus maintain 50 % of total power transmission.

A.2.3.3 Bipolar neutral grounded at one end

The mode of bipolar neutral grounded at one end is shown in Figure A.5. In this mode, the system is not grounded at the converter station end and thus avoids corrosion in the mode of bipolar neutral grounded at both ends. It should be noted that the earth reference shown on Figure A.5 conducts no d.c. current and does not need to be designed as an earth electrode. The disadvantage of this mode is that the operation is not possible when a failure occurs on one line. It also requires the currents in the two poles to be exactly equal, since there is no return path for any unbalance current. Technically, it is possible to use this operation mode; however, no actual project has adopted this scheme.

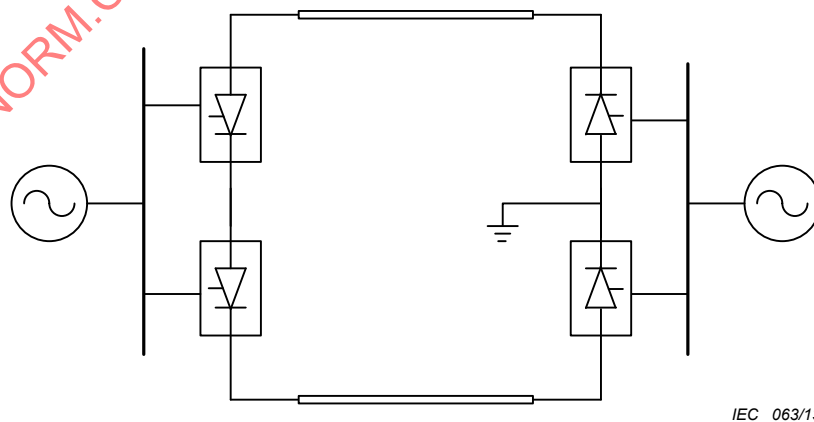

Figure A.5 – Schematic diagram of the structure of bipolar neutral grounded at one end

A.2.3.4 Bipolar neutral line

The mode of bipolar neutral line is shown in Figure A.6. In this mode, in addition to conductors for positive and negative pole, a conductor is used as the neutral line between two converter station neutral points and grounded at one end. This mode not only eliminates the

drawbacks due to earth or sea water being used as the current return circuit, but also allows continuous monopolar operation. In this mode, the earth reference shown in Figure A.6 conducts no d.c. current and does not need to be designed as an earth electrode.

Construction of d.c. power transmission systems typically require a bipolar system to be built in different phases. One pole is often built before the other and operated as a monopolar system to achieve benefits at an early stage. The ± 500 kV Geshang d.c. project and Tianguang d.c. project in China were both constructed in this way.

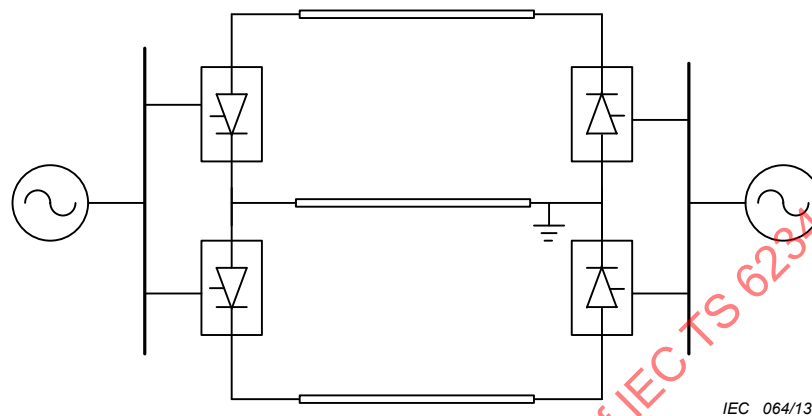

Figure A.6 – Schematic diagram of the structure of bipolar neutral line

A.2.4 Symmetric unbalanced system

A balanced bipolar system consists of two completely identical monopolar systems, which are typically built and put into operation in stages, which means the second monopolar system is built and put into operation shortly after the first one is put into service. If this is not the case and the second monopolar system is built at a late stage according to planning, advancement of relevant technologies in the transition period can lead to different transmission power and voltage rating between these two systems. For instance, the Konti-Skan d.c. system consists of two monopolar systems with different transmission powers, which share a pair of reversible converter stations. The Skagerrak d.c. system was planned to be a balanced bipolar system at the beginning, but now has three monopolar systems. The power transmission direction of the third monopolar system is opposite to that of the bipolar system built at an early stage. The converter station is therefore in an unbalanced operation mode.

A.2.5 Back-to-back converter station

This type of d.c. system that has no d.c. power transmission lines and combines the rectifier station and inverter station together is called back-to-back converter station. Due to the absence of power transmission lines, the d.c. system can select a lower voltage rating, reducing the total investment of the work. Back-to-back converter stations are now widely used with the main purpose of limiting increase of short-circuit current during the interconnection of electric grids, improving the reliability of grid under operation, and serving as a frequency conversion station during the interconnection of grids with different frequencies. Back-to-back converter stations do not require earth electrodes.

A.3 Dangerous impact and accumulated impact

A.3.1 General

The safety risks of d.c. grounding systems mainly involve electric shock due to touch voltage, transferred voltage and step voltage, among which electric shock due to step voltage should receive more attention. The accumulative effects of d.c. grounding systems mainly involve corrosion of the earth electrodes themselves and nearby metallic structures.

A.3.2 Safety risks of d.c. earth electrode

A.3.2.1 General

The touch voltage, transferred voltage and step voltage are shown in Figure A.7.

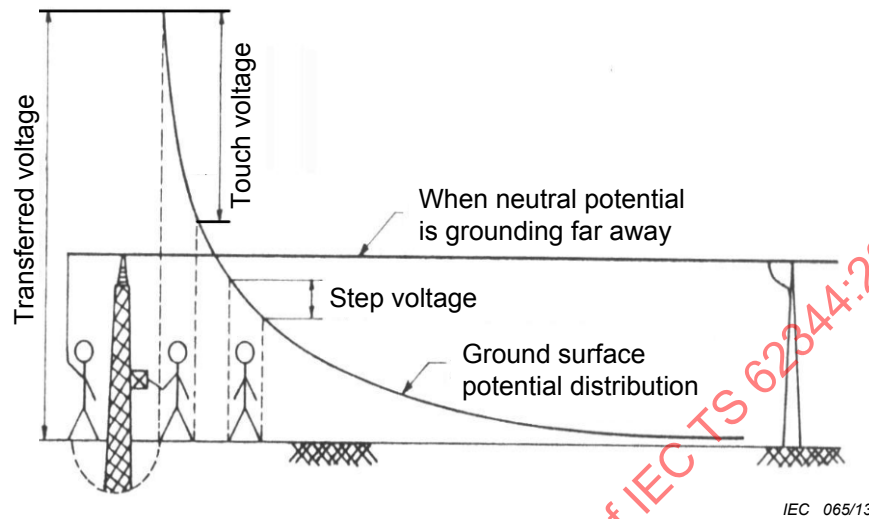

Figure A.7 – Schematic diagram of touch voltage and step voltage

A.3.2.2 Step voltage limit

The step voltage limit is an important basis for the design of earth electrodes. When the step voltage caused by earth electrode current in the ground exceeds a certain value, electric shock due to step voltage may occur. On the other hand, too low a value for step voltage will increase the total cost of the system. Hence the selection of a reasonable step voltage in the neighborhood of the earth electrodes is significant for ensuring personal safety and lowering system costs.

What really poses safety hazards to people is the current flowing through the human body. Hence the step voltage limit depends on physical conditions and the footsteps of people. Impact of step voltage is more significant at lower sensing current, lower human body resistance, lower contact resistance between the human body and the soil, and longer footstep. A low step voltage limit should be defined to ensure personal safety.

The step voltage limit for the human body is calculated with:

$$U = I_g(R + 2R_s) \tag{A.1}$$

where

- U is the step voltage limit (V),
- I_g is the minimum current (A) sensed by a human body,
- R is the human body resistance (Ω), and
- R_s is the contact resistance (Ω) between one foot and the soil.

According to tests conducted on 1 028 subjects, over 95 % of the subjects have a human body resistance greater than 1 400, and over 95 % of the subjects do not feel anything at a d.c. current of 5,3 mA. Based on these test results and considering the different amplitudes and durations of d.c. system earthing currents, the maximum allowed step voltage of any point on the ground can be determined with Formula (3) under maximum overload current of one pole.

Designing earth electrodes based on step voltage limits can ensure the safety of people walking near earth electrodes. For earth electrodes failing to meet the step voltage limit, an isolation wall should be erected in corresponding areas to prevent people from entering these areas and suffering from electric shock.

A.3.2.3 Typical distribution of d.c. earth electrode step voltage

Present-day d.c. earth electrodes are often circular:

a) typical single circular d.c. earth electrode

A single circular d.c. earth electrode structure is shown in Figure A.8, and distribution of step voltage is shown in Figure A.9 and Figure A.10.

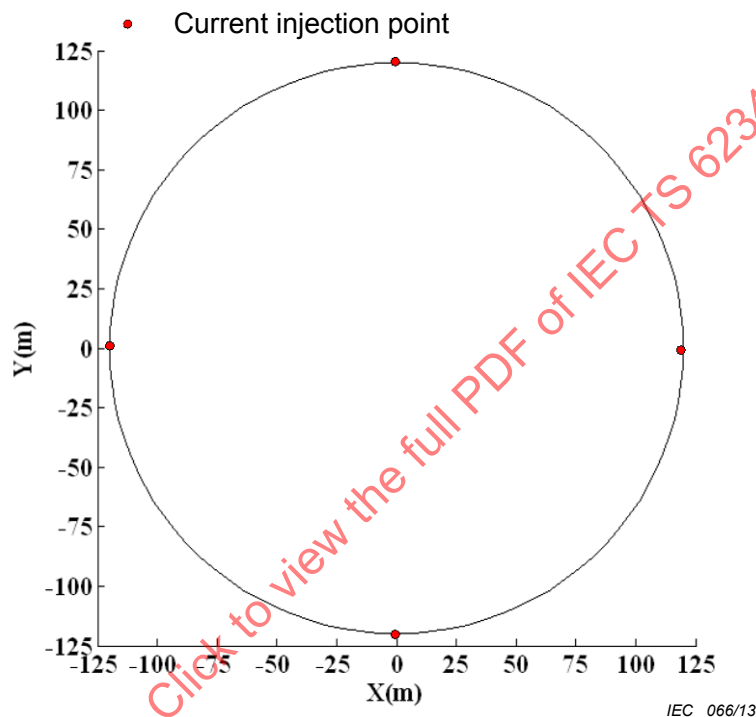

Figure A.8 – Schematic diagram of single circular earth electrode

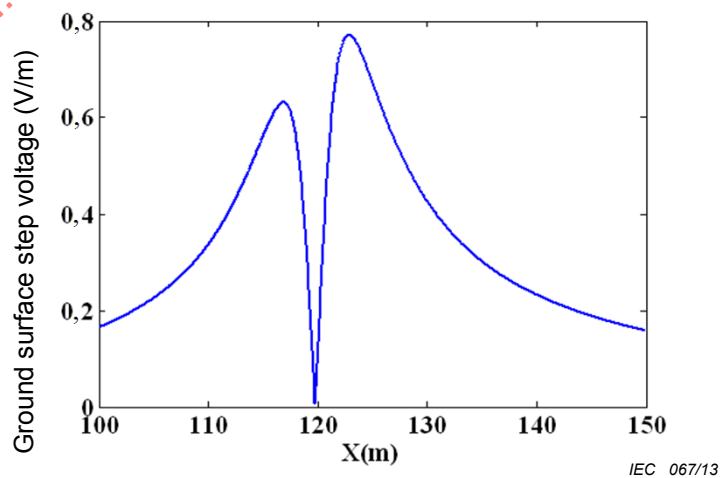

Figure A.9 – Axial distribution of step voltage of single circular earth electrode

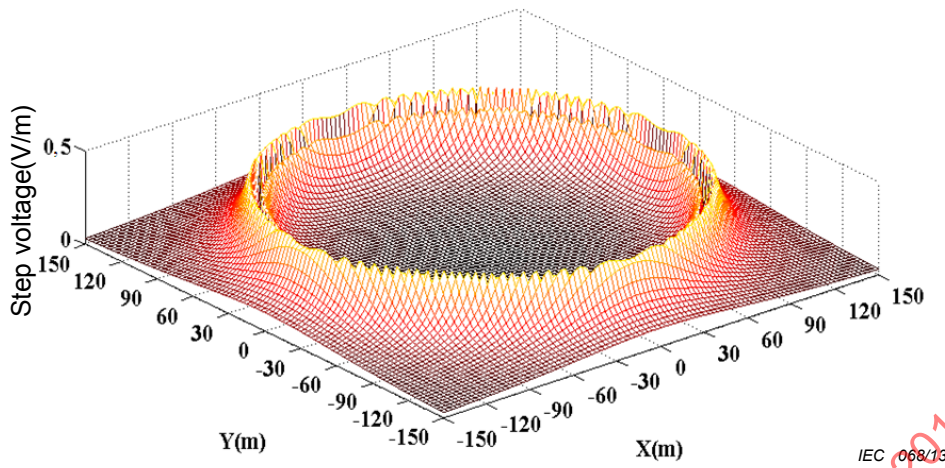

Figure A.10 – 3-D distribution of step voltage of single circular earth electrode

b) typical double circular d.c. earth electrode

A double circular d.c. earth electrode structure is shown in Figure A.11, and distribution of step voltage is shown in Figure A.12 and Figure A.13.

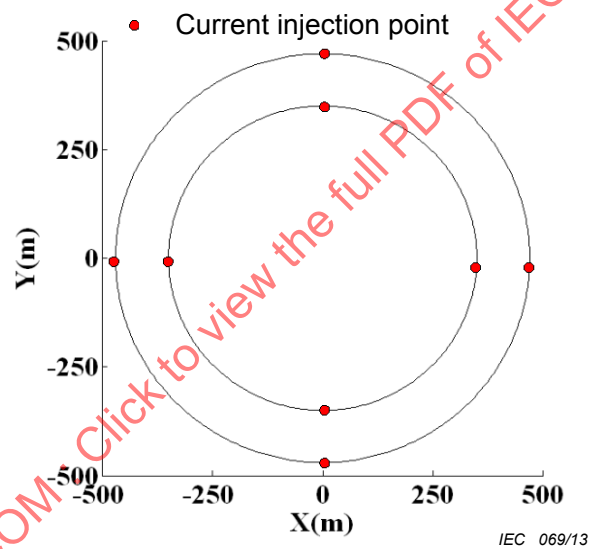

Figure A.11 – Schematic diagram of double circular earth electrode

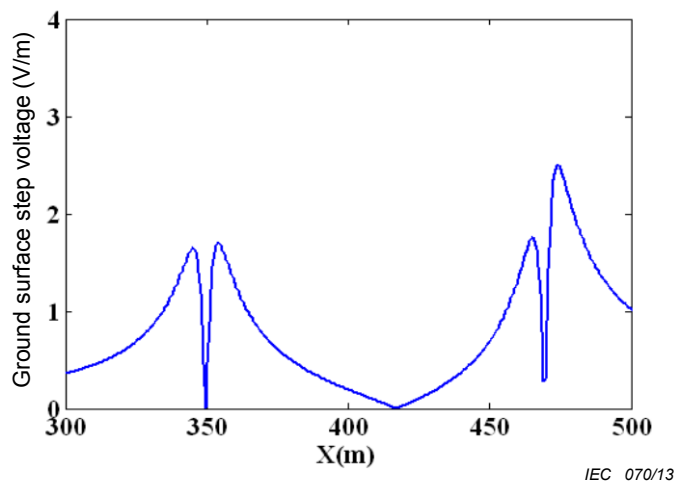

Figure A.12 – Axial distribution of step voltage of double circular earth electrode

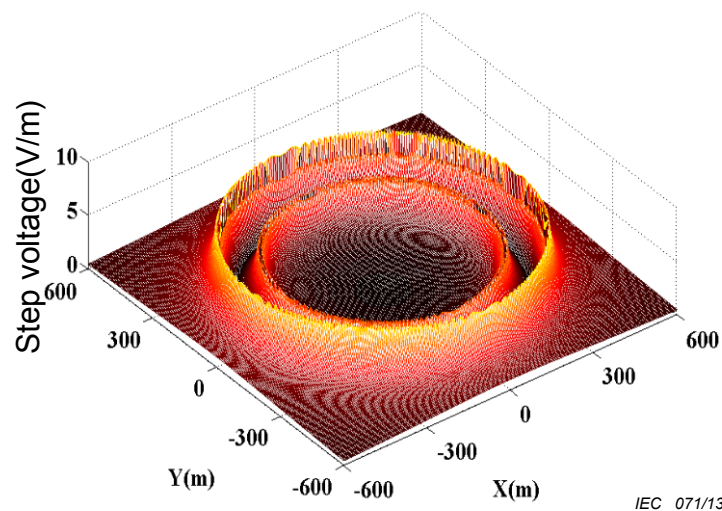

Figure A.13 – 3-D distribution of step voltage of double circular earth electrode

c) typical triple circular d.c. earth electrode

A triple circular d.c. earth electrode structure is shown in Figure A.14, and distribution of step voltage is shown in Figure A.15 and Figure A.16.

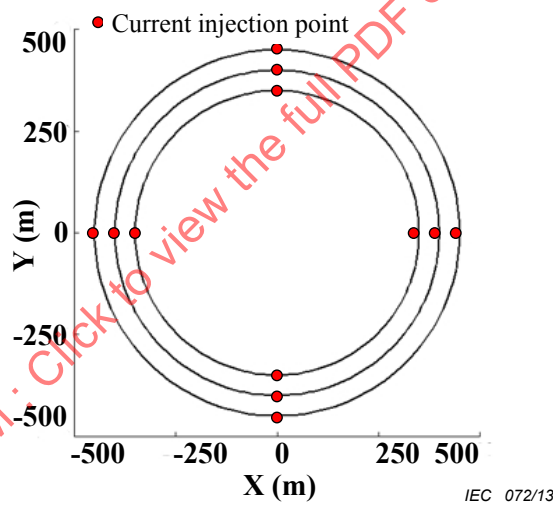

Figure A.14 – Schematic diagram of triple circular earth electrode

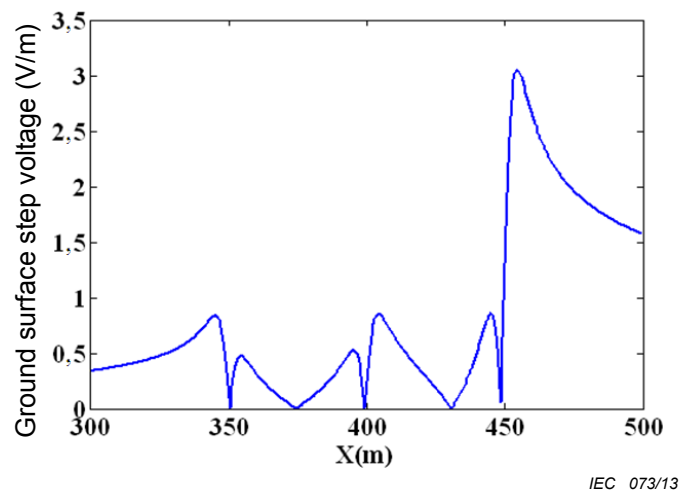

Figure A.15 – Axial distribution of step voltage of triple circular earth electrode

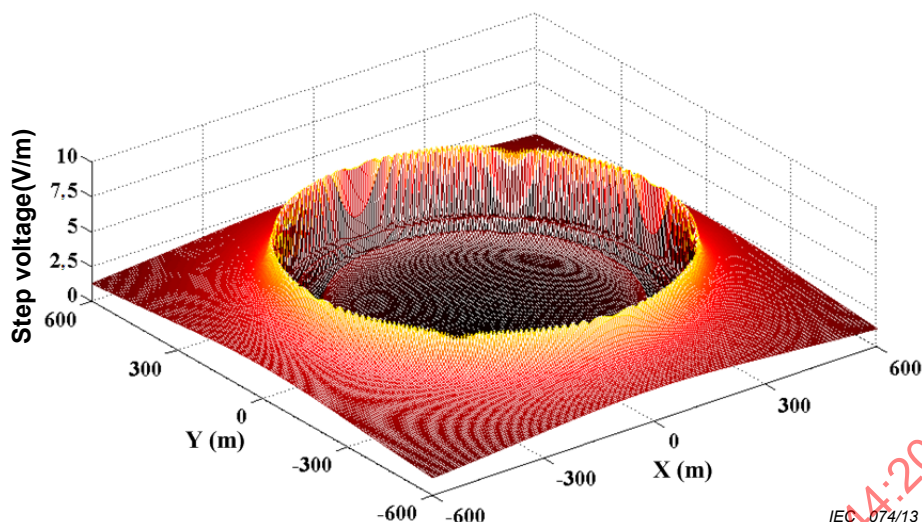

Figure A.16 – 3-D distribution of step voltage of triple circular earth electrode

A.3.3 Accumulated effect of d.c. earth electrodes

The accumulated effect of earth electrodes mainly involves electrochemical corrosion of metal conductors due to d.c. current. During system operation, the earth serves as a giant electrolyte tank, and the d.c. earth electrodes of the converter station at the two ends serve as two electrodes in this electrolyte tank. The process of electrolysis and dissipation continues at the anode according to Faraday's laws of electrolysis, leading to electrochemical corrosion of the d.c. earth electrodes themselves. As the time elapses, the total ampere hours of the earth electrodes in operation continue to increase, causing more serious corrosion of the buried metal conductors. The corrosion of earth electrodes therefore has a typical accumulated effect over time.

One important aspect of well-designed earth electrodes is the ability to ensure safe operation of electrodes throughout the designed service life in spite of corrosion during operation of these electrodes. On the other hand, investment in earth electrode construction should be minimized.

For d.c. earth electrodes, the issue of electrolysis corrosion remains a major challenge as a high current, of the order of kA, is likely to flow through them for a long time. Specific anti-corrosion measures should therefore be taken. When a d.c. power transmission system is operated using earth as the return circuit, the current will flow from the grounded anode to soil and flow back from the cathode to the lines. Flow of current in soil is mostly made possible by electrolyte in the soil.

Low-carbon steel (iron) is now a commonly used anode material as it is widely available and low in price. The electrolysis corrosion process is explained below by using an iron anode as an example.

Chemical equations near the anode:

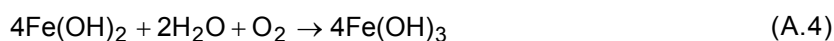

Fe^{2+} ions generated during electrolysis will enter the electrolyte from the anode to react with OH^- ions there, generating ferrous hydroxide, $\text{Fe}(\text{OH})_2$. Ferric hydroxide, $\text{Fe}(\text{OH})_3$, is the product of further oxidation (a reddish-brown unconsolidated material). This process will continue to consume anode metal. Consumption of metal anode during electrolysis can be calculated below based on Faraday's laws:

$$m = \frac{A_m}{KF} It \quad (\text{A.5})$$

where

- m is the consumption of metal material (g);
- A_m is the molar mass of the metal (g/mol);
- K is the metal valence, dimensionless;
- F is Faraday's electrolytic constant, $9,648\ 53 \times 10^4$ C/mol;
- I is the current flowing through the metal (A);
- t is the current flowing time (s).

As the molar mass and valence of iron are 55,86 g/mol and 2 respectively (ferrous ions with valence 2 are generated during electrolysis), for each ampere of current flowing through the iron anode, the annual consumption of the anode can be calculated as follows:

$$m = \frac{55,86}{2 \times 9,648\ 53 \times 10^4} \times 1 \times 365 \times 24 \times 60 \times 60 = 9\ 128,86 \text{ [g]} \quad (\text{A.6})$$

In case of bipolar connection, suppose the rated current of each pole is 1 kA, the unbalanced current in normal conditions is 30 A, and the monopolar operation rate is 1 %, then the annual consumption of the iron anode can be as high as:

$$m = 9\ 128,86 \times (30 \times 0,99 + 1\ 000 \times 0,01) = 3,62 \times 10^5 \text{ [g]} = 362 \text{ [kg]} \quad (\text{A.7})$$

It can be seen that the anode material is significantly corroded due to electrolysis. If the earth electrode has a designed life of 30 years, which means 40 % of earth electrodes can be consumed after 30 years, earth electrodes will require 27,15 tons of steel.

Anti-corrosion of the earth electrodes is an issue that cannot be overlooked during design of earth electrodes. The solutions are typically selected from the perspectives of anode material selection, structure and shape optimization, and proper anti-corrosion measures, such as anti-corrosion coating and cathode protection.

A.4 Impact on an a.c. grid

A.4.1 General

In general by far the most difficult problems that may arise in the performance of ground return mode of operation, concerns the influence on a.c. power systems. Such problems would likely be due to the resistivity profile of the ground over vast areas around the electrode and the relative location of infrastructures like a.c. substations and the configuration of electrical power systems.

The necessary and effective protection for ground d.c. excitation of transformers is to locate the electrode station at a certain distance from any vulnerable substation, including the converter station.

A.4.2 D.C. current path to a.c. system

A.4.2.1 General

The basic cause of effects of HVDC transmission in ground return mode on to the a.c. system is due to the gradient of ground potential rise caused by return of d.c. current through the ground. The main paths that d.c. current follows into a.c. system include the shielding wire(s) and the grounded star point of a.c. transformer(s).

A.4.2.2 Shielding wire

When the shielding wires are continuous, part of the picked-up current follows these wires. Intermediate towers close to the anode pick up further fractions of current, while towers close to the cathode discharge corresponding fractions. The principal risk is corrosion of the anodic part.

A.4.2.3 Grounded star point of a.c. transformer

Due to the earth potential gradient, d.c. current enters the grounded star point of a.c. transformer A, follows the high-voltage phases to transformer B and leaves through the star point connection and ground grid of substation B. The transformers most affected by d.c. current will be in the vicinity of either electrode stations as the ground potential gradient is steep only in the vicinity of electrode stations.

A.4.3 D.C. magnetic bias of a.c. transformer

A.4.3.1 General

The d.c. component through the transformer windings provokes a constant magnetising of the core, which, superimposed on the symmetrical a.c. magnetising, lets the flux vary in an unbalanced way, which in one flux direction may lead to saturation of the core. Both YY and YD type of transformers will have flux offset by the ground potential rise. As the transformer operates in the nonlinear portion of its magnetizing curve, the magnetizing current will consist of a series of harmonic currents. The wave form of the current is destroyed mainly due to a rise in the content of the second harmonics. Generally there will also be a rise of several other positive, negative and zero sequence harmonics, particularly 3rd harmonic current.

The vulnerability to d.c. magnetizing is different for different core types. Monophase transformers with magnetic return equal in area to the wound leg are strongly affected. Three-phase, five-legged transformers also react to some degree. Three-phase, three-legged transformers will withstand a high level of d.c. current excitation.

A.4.3.2 Three-phase, three-legged transformer

The tank of the three-legged transformer, for zero sequence flux, acts like a single turn secondary winding and large currents may be induced in the tank causing its overheating.

A.4.3.3 Three-phase, five-legged transformer

In three-phase, five-legged transformers, the return legs carry more d.c. flux are more likely to saturate than the phase legs. Once the outer legs are saturated, the transformer for further excitation acts almost like a three-legged transformer.

A.4.3.4 Reactor

Reactors with magnetic cores, for compensation purposes, are not at all exposed to d.c. saturation. This statement is valid whether the reactors are monophasic or three-phase, with three- or five-legged cores.

A.4.3.5 Saturation time constant

The rise of the harmonics in the transformers with saturation depends on the time constant of the circuit through which the d.c. current would circulate. Generally, this time constant is of several seconds and full harmonic current peaks due to saturation are not reached until almost a minute after the rise of ground potential. Within this time it is generally possible to transfer the system to metallic return configuration.

A.4.3.6 Saturation analysis

When analyzing the possibility of saturation, the grid composition is usually much more complicated. A detailed resistance network containing the different stations, the mutual interconnection between stations and the resistance in transformers should be set up, and the flow in the different branches calculated.

Generally speaking, the problem of saturation is not very serious for the huge number of small grid transformers (<200 MVA), because they are normally three-phase, three-legged. Attention will be drawn to large monophasic units and to large three-phase units, which are often five-legged to reduce height in order to facilitate transportation.

Annex B
(informative)

Soil parameter measurement method

B.1 General requirements

During the design of earth electrodes, the main physical parameters of the soil on the electrode site should be measured in order to determine the electrical parameter model of the site, thermal properties of soil and evaluate the impact of the earth electrodes on the environment. The main physical parameters of soil include soil resistivity, soil thermal capacity, soil thermal conductivity, soil highest natural temperature, soil moisture, and groundwater table.

Common soil (rock) resistivity values are listed in Table B.1. Soil thermal capacity values are listed in Table B.2. Soil thermal conductivity values are listed in Table B.3. Due to the importance of these 3 parameters, they shall be measured at the electrode sites, especially for the soil resistivity. Some measurement methods of soil resistivity are listed in B.2

Table B.1 – Soil (rock) resistivity

Substance	Soil (rock) name	Resistivity (Ω·m)	Remarks
Water	Rainwater	$>10^3$	Related to the content of conductive substances in water
	River water	$10\sim 10^2$	
	Sea water	$5 \times 10^{-2}\sim 1$	
	Ground water	$10^{-1}\sim 3 \times 10^2$	
	Ice	$10^4\sim 10^8$	
Soil	Clay, silty clay	$10\sim 10^3$	Related to the content of water and conductive substances
	Silt		
	Wet sand		
	Dry sand, pebble	$10^3\sim 10^5$	
Sandstone	Grgillaceous shale	$20\sim 10^3$	
	Tight sandstone		
	Red sandstone	$10\sim 10^2$	
Limestone	Muddy limestone	$50\sim 8 \times 10^2$	
	Limestone	$3 \times 10^2\sim 10^4$	
Rock	Granite	$2 \times 10^2\sim 10^5$	Highly related to the moisture content
	Granodiorite		
	Diorite		
	Basalt		
	Gabbro		
	Porphyrite		
	Peridotite		
	Schist	$2 \times 10^2\sim 10^4$	
	Gneiss	$2 \times 10^2\sim 2 \times 10^4$	
	Dolomite	$10^2\sim 10^4$	
	Carbonate rock	$10^4\sim 10^8$	

Substance	Soil (rock) name	Resistivity ($\Omega \cdot m$)	Remarks
Mineral	Gypsum	$10^2 \sim 10^8$	Related to the minerals and moisture content
	Copper pyrite	$10^{-4} \sim 10^{-1}$	
	Magnetite	$10^{-4} \sim 10^3$	
	Hematite	$1 \sim 10^5$	
	Quartz	$> 10^6$	
	Mica	$> 10^8$	

Table B.2 – Soil thermal capacity

Soil type	Thermal capacity $J/(m^3 \cdot ^\circ C) \times 10^6$		
	Dry	50 % wet saturation	100 % wet saturation
Sand	1,26	2,13	3,01
Clay	1,00	2,22	3,43
Humus	0,63	2,18	3,77

Table B.3 – Soil thermal conductivity

Soil type	Thermal conductivity $W/(m \cdot ^\circ C)$	
	Dry	Wet
Sand	0,27	1,85
With silt and clay	0,43	1,90
Soil with fine sand	0,33	2,3
Silt soil	0,37	0,88
Clay with sand	0,42	1,95
Volcanic soil	0,13	0,62
Black agricultural soil (frozen)	0,18	1,13
Brown natural soil (frozen)	0,08	1,20
Yellow-brown natural soil (frozen)	0,10	0,82
Gravel with sand and silt	0,55	2,55
Ice (0 °C)		2,22

B.2 Measurement of resistivity of surface soil

B.2.1 Measurement method of resistivity

B.2.1.1 General

The resistivity of the soil surface should be measured with a field geophysical survey method to ensure the accuracy of the results. Among the most frequently used geophysical survey methods in current measurements are Wenner, Schlumberger and dipole-dipole methods.

B.2.1.2 Wenner method

The equivalent circuit for this measurement method is shown in Figure B.1. The apparent resistivity can be calculated with Formula (B.1).

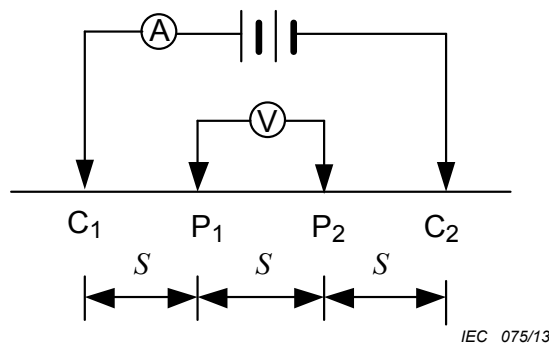

Key

- S pole distance (m)
- V voltage meter
- A current meter
- P_1, P_2 voltage pole
- C_1, C_2 current pole

Figure B.1 – Equivalent circuit of Wenner method

$$\rho_s = 2\pi S \frac{U}{I} \tag{B.1}$$

where

- I is the measurement result of current meter (A);
- ρ_s is the apparent resistivity of earth ($\Omega \cdot m$);
- S is the pole distance (m);
- U is the measurement result of voltage meter (V).

B.2.1.3 Schlumberger method

The equivalent circuit for this measurement method is shown in Figure B.2. The apparent resistivity can be calculated with Formula (B.2).

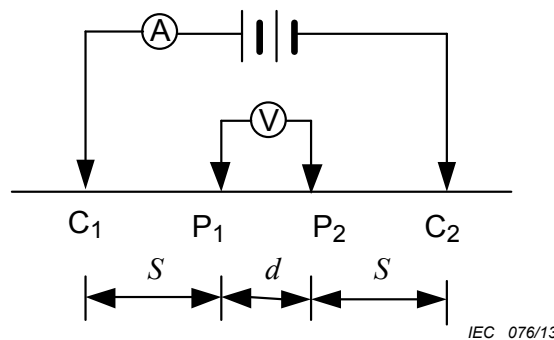

Key

- S pole distance (m)
- d distance between voltage poles
- V voltage meter
- A current meter
- P_1, P_2 voltage pole
- C_1, C_2 current pole

Figure B.2 – Equivalent circuit of Schlumberger method

$$\rho_s = \pi \frac{S(S+d)}{d} \frac{U}{I} \quad (\text{B.2})$$

where

- ρ_s is the apparent resistivity of earth ($\Omega \cdot \text{m}$);
- S is the distance between current poles and voltage poles (m);
- d is the distance between voltage poles (m);
- U is the reading of voltage meter (V);
- I is the reading of ammeter (A).

B.2.1.4 Dipole-dipole method

The equivalent circuit for this measurement method is shown in Figure B.3. The apparent resistivity can be calculated with Formula (B.3). It is especially useful for measuring lateral resistivity changes and has been increasingly used in geotechnical applications.

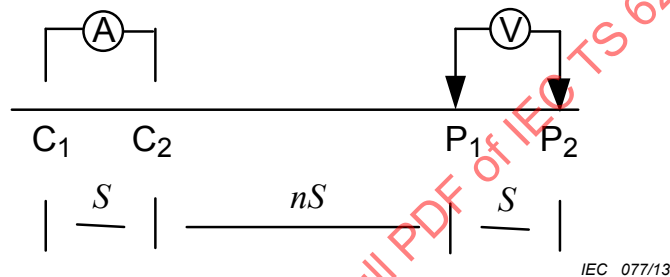

Key

- S distance between current poles (voltage poles) (m)
- nS distance between the adjacent current pole and voltage pole (m)
- V voltage meter
- A current meter
- P_1, P_2 voltage pole
- C_1, C_2 current pole

Figure B.3 – Equivalent circuit of dipole-dipole method

$$\rho_s = \pi S \cdot n(n+1)(n+2) \frac{U}{I} \quad (\text{B.3})$$

where

- ρ_s is the apparent resistivity of earth ($\Omega \cdot \text{m}$);
- S is the distance between current poles (voltage poles) (m);
- n is the ratio of distance between the adjacent current pole and voltage pole, and distance between current poles;
- U is the reading of voltage meter (V);
- I is the reading of ammeter (A).

B.2.2 Measurement requirements

The measurement is made with d.c. power supply and d.c. meters.

During measurement, the meter accuracy, error and data should be calibrated properly.

The resistivity should be measured at different measurement points (center location of current poles). Measurement points generally have a uniform distribution at the electrode site. Because information of shallow layers will be obtained usually when pole distance is short, measurements with short pole distance should be conducted at more measurement points due to the importance of resistivity model of shallow layers. Table B.4 provides an example for resistivity measurement.

Table B.4 – Number of measurement points with different pole distances

Pole distance (m)	2	5	10	15	20	30	50	70	100	150	200	300	500	700	1 000
number of measurement points (point/km ²)	49					36			25		16		9	4	

If the voltage probe pole distance is longer than 300 m, measures should be taken (such as increasing testing current or using compensation) to reduce the impact of disturbance current in soil on the measurement results and achieve an error not exceeding 5 %, and measurement wires should be deployed in two directions that are vertical to each other.

B.2.3 Measurement range

The soil resistivity measurement range should be larger than the area of the earth electrode. The pole distance should be no shorter than 1 000 m.

B.2.4 Data accuracy

To ensure accurate results, during soil resistivity measurement, two groups of data should be read by switching the power supply connection polarity of the same measurement point at the same measurement depth (pole distance). Repeat the measurement if the difference between both data groups is higher than 5 %.

B.2.5 Seasonal coefficient

The seasonal coefficient of soil resistivity should be considered. At the place where the earth electrode is buried, a few representative permanent marks should be erected so that measurement of soil resistivity can be performed at the same place during the dry season (when the soil is dry).

B.2.6 Processing of measurement data

With the above measurement method, the apparent resistivity at different depths of different segments on the electrode site can be achieved. Formula (B.4) is used for processing the equivalent apparent resistivity measured at the same depth.

$$\rho_m = \frac{N}{\sum_{n=1}^N \frac{1}{\rho_n}} \tag{B.4}$$

where

- N is the number of soil segments;
- ρ_m is the equivalent apparent resistivity measured at the same depth ($\Omega \cdot m$);
- ρ_n is the apparent resistivity at the same measurement depth ($\Omega \cdot m$).

Based on Formula (B.3), a group of data concerning the variance of equivalent apparent resistivity depending on the depth on the electrode site can be achieved. Calculation is then

made with this data with soil layering software to achieve a surface electrical property model on the electrode site.

B.3 Measurement of resistivity of deep soil (MT method)

During the creation of the electrical parameter model for the electrode site, the earth resistivity needs to be measured from the surface to a depth (range) tens of kilometers below the ground surface. Normal geophysical survey methods do not apply to the measurement of earth resistivity at a deep level. The magnetotelluric method (MT method) widely used in mine exploration should be adopted, which makes it easier to measure the earth resistivity at a deep level.

This is an electromagnetic measurement method based on the MT induction principle using alternating electromagnetic field as the natural field source. In the MT method, two horizontal components of the electric field that are perpendicular to each other (E_x and E_y) as well as three components of the magnetic field that are perpendicular to each other (H_x , H_y and H_z) are recorded successively at the same point and same time. The wave impedance (Z) at the point can be calculated. When the MT field is distributed uniformly along all directions and horizontally layered, the impedance $Z = E/H$. After transformation, variation of Earth crust with the period T can be determined (apparent resistivity curve) and expressed with $\rho_a = 0,2|Z|^2$.

This method uses the skin effect principle and treats the skin effect depth as the exploration depth:

$$H = \sqrt{\frac{\rho}{\pi f \mu}} \quad (\text{B.5})$$

where

- H is the exploration depth (m);
- ρ is the apparent resistivity ($\Omega \cdot \text{m}$);
- f is the frequency, can be as low as 0,000 1 (Hz);
- μ is the soil permeability (H/m).

By changing the frequency, values of apparent resistivity at different exploration depth can be achieved, which are then processed by the computer (software) to obtain a deep-level electrical parameter model of the electrode site.

As the MT method makes use of the inductive coupling effect of alternating electromagnetic fields, it can penetrate high-resistance layers that can hardly be penetrated by d.c. exploration. Hence as long as a suitable frequency band is selected, the MT method can detect the variance of underground electrical properties at a depth from a few hundred meters to a few hundred kilometers. Due to these features, the MT method has become a very effective method in exploration of minerals such as petroleum, especially during the evaluation of electrical properties of deep layers.

B.4 Measurement of soil thermal capacity

The thermal capacity of the soil layer where the electrode is buried should be measured. The thermal capacity of the soil is defined as the energy required for raising the temperature of unit volume of soil by one degree Celsius. The soil thermal capacity is typically measured with a heat-insulating calorimeter in a lab. The measurement method can use either continuous heat sources or intermittent heat sources.

With the intermittent heat source method, the sample in an insulation jacket is heated intermittently at a constant power. Curves of temperature variation over time are drawn to

derive a relation between enthalpy and temperature and corresponding specific heat of the sample. As the enthalpy in the sample is uniformly distributed due to intermittent heating, this method is often used for high-precision measurement.

With the continuous heat source method, the sample is continuously heated in an insulation jacket at a constant power. The specific heat can be calculated based on the temperature rise and enthalpy of the sample after it has been heated for a while. The thermal capacity is the product of the specific heat capacity and density.

Samples delivered to the lab should be collected from each typical deep soil layer on the selected electrode site. The original conditions and moisture of the soil should be maintained during sampling. The number of samples should not be lower than the total number of soil types on the site and should be no less than 10.

B.5 Measurement of soil thermal conductivity

The thermal conductivity of the soil layer where the electrode is buried should be measured. The thermal conductivity refers to the heat transferred every second when the temperature difference between two ends of unit length and area of soil is 1 °C. Measurement of thermal conductivity can be performed in a lab or on the site.

For measurement of thermal conductivity in a lab, samples need to be obtained and delivered. Requirements for samples delivered to the lab for such measurements are the same as those for samples used for thermal capacity measurements. Two methods are available for measurement of soil thermal conductivity. With the first method, soil samples are placed in two round metal plates with known thermal conductivity with one end being heated. A set of thermocouples are used to measure temperature at both ends, and a sensing device is used to measure the heat flux of the sample. After heat flux measurement for a period of time, for example 10 min to 2 h, the thermal conductivity is obtained by multiplying the heat flux through the meter with the sample thickness and then dividing the product by temperature difference. With the second method, the soil sample is produced into round thin pieces (e.g. with a diameter of about 8 mm and a thickness of about 1 mm). After the sample surface is heated by laser instantaneously, the thermal diffusion coefficient is obtained based on the temperature rise on the back of the sample. Next, the soil thermal conductivity is achieved by multiplying the thermal diffusion coefficient with a specific heat and density. As the original conditions of soil and consequently measurement results are changed during this process, site measurement is sometimes used instead.

Site measurement can also be made with the static or instantaneous method. With the static method, a buried ball is heated until uniformly distributed heat flux can be achieved. As this process often lasts for a few days, it is often impractical. With the instantaneous method, a cylinder measurement pole equipped with heater and temperature measurement components is inserted into soil at a desired depth. The heater supplies heat suddenly and the heat is transferred into the soil at a constant rate. In the meanwhile, the temperature rise at the contact between the measurement pole and the soil is monitored to determine the correlation between soil temperature rise and heat output over time. Thermal conductance theory is then used based on this data to calculate thermal conductivity. Generally, this method only requires one hour.

B.6 Measurement of maximum natural temperature of soil

The best way to determine the maximum natural temperature of soil is on-site measurement or acquisition of relevant data in at least two recent years, from the meteorological authority. During the measurement of soil temperature, a thermistor thermometer should be adopted, and other considerations include measurement points with different geological conditions as well as highest temperature in summer and lowest temperature in winter at different depths. The minimum measurement depth should not be less than the depth of the buried earth electrode. In areas without terrestrial heat source and with distinct seasons, the maximum

natural temperature of soil can be calculated as the maximum ground temperature over the year, minus 10 °C, and the minimum natural temperature of soil can be calculated as minimum ground temperature over the year, plus 10 °C.

B.7 Measurement of soil moisture and groundwater table

For an electrode site in a wet low-lying area, measurements should be made to find the parameters such as soil moisture and permanent groundwater table. The electrode site groundwater table can be obtained by consulting hydrological and geological maps or field investigation. To measure soil moisture, soil samples are often taken on the site and delivered to the lab, where the weight loss method is used to measure and find the moisture content of soil.

B.8 Measurement of soil chemical characteristics

For land electrodes near the sea and those in outback saline and alkaline land, soil parameters such as content of Cl^- , SO_4^{2-} ions and pH value should be measured to determine soil corrosiveness. Measurement of soil chemical characteristics is typically completed by taking soil and water samples on the site and testing them in a lab.

B.9 Geological exploration

The drilling method is used to find the soil types on the electrode site and thickness of cover soil. The exploration range should match the layout of earth electrodes. The exploration should reach the depth of bedrock.

B.10 Topographical map

1:1 000 or 1:2 000 topographic maps are drawn during measurement. The measurement range should match the layout of earth electrodes.

Annex C (informative)

Electrode line design

C.1 Overview

The power lines used to connect d.c. converter station neutral buses and d.c. earth electrode current guiding systems are typically called electrode lines, which serve the main purposes of guiding the converter station earthing current out of the station and to the d.c. earth electrode, preventing both the corrosion of the grounding metal system in the converter station and rise of earth potential in the converter station, and avoiding magnetic saturation of the transformer and its effect in the station. Electrode line is an important part of the whole d.c. power transmission system. When the d.c. power transmission system runs in monopolar earth return mode, the current flowing through the electrode lines is equal to that in the d.c. lines. The electrode lines feature high rated current, low operation voltage, and, for some types of d.c. systems, short operation time at rated current.

The rated current of electrode lines is that of the d.c. power transmission system, which depends on the rated power transmission capacity and the rated voltage of this system. The rated current of a d.c. power transmission system is typically between a few hundred and a few thousand amperes.

The operation voltage of electrode lines is the voltage drop on the earth electrode and electrode lines caused by the current flowing through electrode lines. This voltage is related to factors such as the current flowing through electrode lines, line length, conductor resistance, and earth electrode earthing resistance. When a rated current flows through electrode lines, the operation voltage at the end of electrode line converter station is usually no higher than 10 kV, and at the earth electrode end is usually no higher than 1 kV. The operation voltage is even lower if the current flowing is a bipolar balanced current.

For a bipolar balanced d.c. power transmission system, the operation duration of electrode lines at rated current is the time for the bipolar balanced d.c. power transmission system to run in monopolar earth return mode, which is typically no longer than one year, or even as short as a couple of days.

For a monopolar earth return d.c. power transmission system, the operation duration of electrode lines at rated current is the operation duration of the d.c. power transmission system.

C.2 Main design principles

The main principles for electrode line design are the following:

- a) design of electrode lines should comply with system operation requirements to ensure safe, reliable, and cost-effective operation, facilitate construction, operation and maintenance, save resources, and protect the environment;
- b) determination of meteorological conditions should be based on calculation and analysis using the data provided by meteorological stations near the project lines and collected through meteorological field surveys. Wind pressure maps can be consulted, and the operation experiences of existing power lines can be drawn on. The design standards of similar d.c. power transmission systems with appropriately reduced voltage levels can be used as a reference;
- c) selection of electrode line routes, safety factors for conductors, earth wires and electric power fittings, and design of tower and infrastructure can use d.c. line design standards of

similar d.c. power transmission systems with appropriately reduced voltage levels as a reference;

- d) conductors should be selected by giving full consideration to operation characteristics of electrode lines and making comparisons based on rated current, terrain in areas where the lines are deployed, ice-coating, and wind speed;
- e) insulation coordination of electrode lines should be designed in such a way as to ensure reliable operation in different conditions including normal operation voltage, lightning overvoltage, and live-line operation;
- f) the distance of electrode line conductors to earth and distance between conductors at crossings can be determined according to design standards of 110 kV a.c. lines in principle.

C.3 Selection and layout of conductor and earth wire

C.3.1 Selection of conductor

For the electrode lines of bipolar balanced d.c. power transmission systems, in consideration of short operation time at rated current, low operation voltage, and typically short lines, selection of cross-section of conductors should preferably be selected based on the current-carrying capacity allowed for heating.

For the electrode lines of monopolar earth return d.c. power transmission systems, selection of the cross-section of conductors should consider economic current density and is typically be the same as that of d.c. line conductors.

During the selection of electrode line conductors, there is no need to consider electric field effects such as ground electric field intensity and ion current density or check corona effects such as corona loss, radio disturbance and audible noise. Combination of electrode line conductors should follow the principles of minimising the number of branches, easy deployment, and high reliability.

The conductor types should be determined through technical and economic comparison of conditions such as terrain in areas where the lines are deployed, ice coating and wind speed.

C.3.2 Selection of earth wire

The earth wire should meet electrical and mechanical requirements during operation. Galvanized steel wire strand or aluminium clad steel wire strand is usually chosen for this purpose.

C.3.3 Layout of conductor and earth wire

For the sake of monitoring and protection of current-carrying capacity and lines, multiple sub-conductors with the same potential are often used for electrode lines. If potential is the only consideration, different sub-conductors can be bundled without insulation. However, because electrode line fault monitoring devices often use high-frequency pulses to detect line failures, the electrode line sub-conductors need to be grouped into two mutually insulated bundles. In addition, for single-circuit electrode lines, separating the electrode line sub-conductors into two groups and deploying them on two sides of a tower can reduce the mechanical stresses on the tower and hence reduce the weight of the tower. For the above-mentioned reasons, electrode line conductors are typically separated into two groups and deployed symmetrically on two sides of the tower. Since the two conductor groups have the same potential, the horizontal distance between conductors in the middle of the span length can be determined based on the following principle: The two groups of sub-conductors will not collide with each other when they don't swing simultaneously in strong wind.

Considering the short distance between two groups of sub-conductors of electrode lines, electrode lines only need one earth wire, which can be placed on top of the tower.

C.4 Insulation coordination and earthing for lightning protection

C.4.1 Minimum gap between live parts and tower components

The minimum gap between live parts and tower components can be determined by consulting design standards for 35 kV a.c. lines.

C.4.2 Type and number of insulators

Given the low operation voltage of electrode lines, one piece of insulator will be enough from the perspective of electrical properties. However, due to the importance of electrode lines and the possibility of a short-circuited insulator, at least 2 pieces of insulators are used in most occasions. As far as the type of electrode line insulator is concerned, d.c. insulator should be selected.

C.4.3 Arcing horn gap

To prevent the insulators from being burnt by continuing d.c. current when the electrode line insulator string is broken through by lightning, the insulator string is often equipped with an arcing horn. The gap of the arcing horn should be designed in such a way to effectively protect the insulators after electrode lines are hit by lightning. In general, the gap should be less than 0,85 times the effective length of insulator string, and should not exceed the gap under lightning overvoltage. Also, the arcing horn gap should be able to quench the arc effectively within a short time so as to interrupt continuing d.c. current.

C.4.4 Earthing for lightning protection

As the insulation level of electrode lines is very low, installation of an earth wire will not significantly reduce the probability of the lines being hit by lightning. Typically, an earth wire is not necessarily used for a whole electrode line. To protect converter station equipment, an earth wire can be installed within a radius of 2 km to 3 km of the converter station.

In segments where the earth wires are installed, the distance between earth wires in the middle of the span length is dependent on the span length, and should generally be no shorter than $0,001 2 \times L + 1$ m (L representing the span length). The conductor protective angle of the earth wire at the tower head should not be larger than 30° .

The tower should be grounded at the base. The power frequency earthing resistance of the tower can be determined based on relevant requirements for a.c. lines.

C.5 Other considerations

To prevent earth electrode earth current from flowing between the bases of towers near the electrode site and causing electric corrosion of the tower bases, the bases of towers within a radius of 2 km to 3 km of the electrode site should be insulated from earth for most part and grounded with one point. The earth wires within a radius of 10 km of the site should also be insulated from earth. Base insulation is usually provided by bitumen and glass cloth (2 layers of bitumen and 3 layers of glass cloth) that wrap around the bases. The earthing resistance of tower bases should be higher than 500.

Annex D (informative)

Assessment of measurement method

D.1 General guidance

Upon completion of earth electrode installation, acceptance tests and system commissioning tests should be carried out before the system is put into operation. During acceptance tests, the main characteristic parameters of the earth electrode station should be measured including the current distribution of the current guiding wire, earth electrode earthing resistance, and maximum step voltage, etc. The tests are intended to check compliance of the earth electrode station with design specifications and provide a basis for determining if the system is ready for commissioning tests. During system commissioning tests, in addition to checking the above main characteristic parameters of the earth electrode body with system earthing current, some other parameters should be measured including ground potential distribution near the electrode and electrode temperature rise if the system commissioning process allows the current to flow through the earth electrode continuously for a long time so as to provide basis for evaluation of impact on environment and thermal properties of the earth electrode during its operation. Data concerning the earth electrode obtained in the above tests can be used as the background parameters for operation of the earth electrode, and also as reference for evaluation of operation conditions of the earth electrode in the future.

D.2 Experiment (testing) items

D.2.1 Visual inspection of the earth electrode

D.2.1.1 Inspection of the construction records of the earth electrode

Check compliance of the earth electrode cross-section area and burial depth with design specifications. Check tightness and reliability of the welding between different feeding rods and between feeding rods and cables as well as insulation sealing.

D.2.1.2 On-site inspection of the earth electrode site

Clear facilities that may affect normal operation of the earth electrode. Repair sites destroyed during construction. Check compliance of the layout and installation sizes of the earth electrode with design specifications.

D.2.1.3 Inspection of current guiding system

Check that the wiring of current guiding system and installation of its accessories are correct, complete and reliable. Check that the distance between conductors and earth (tower) is correct.

D.2.1.4 Insulation inspection

Check good insulation from earth of the earth electrode current-guiding construction and its base (with the earthing part disconnected).

D.2.1.5 Inspection of water penetration (filling) and detection devices

Check compliance of layout and installation of water penetration (filling) and detection devices with design specifications.

D.2.1.6 Inspection of safety precautions

Check safety marks and precautions. Ensure that the marks are intact, clear and readable.

D.2.2 Current guiding system current distribution measurement

The current distribution of the current guiding system can be measured in acceptance tests or in the system commissioning or in both.

During the acceptance test, a d.c. current no lower than 10 A should be injected into different electrode segments and the earth electrode (as a whole) to measure the current flowing through different branches in the current guiding system. This operation is intended to check compliance of design, construction and installation of the earth electrode and current guiding system with safety operation requirements. Any issue discovered should be addressed promptly:

- a) inspection of welding quality. Inject a d.c. current into each electrode segment through the current guiding wire connected to the electrode segment, and measure the current in different feeding cables on the electrode segment under test. Where a tested branch has two or more parallel feeding cables, the current in these cables should be measured separately. The quality of welding on the feeding cables and feeding rods of an electrode segment is satisfactory if the current of different feeding cables is roughly the same (which is related to soil resistivity);
- b) inspection of current distribution properties. Disconnect the electrode line with the converter station or disconnect the current guiding wires with the electrode line, and inject a d.c. current into the earth electrode at the disconnection point. Measure the current in different current guiding wires. The tested current flowing through different current guiding wires multiplied by the scale factor (rated current / total testing current) should be roughly equal to the design value. If the current flowing through any current guiding wire exceeds the design limit, the design of the current guiding system should be modified.

These two tests can also be conducted together.

During system commissioning, inject a continuous current no lower than 50 % of the rated current into the earth electrode. Measure the current flowing through different branches of the current guiding system in normal operation conditions and during line disconnection to further check compliance of the design of the current guiding system with specifications.

D.2.3 Measurement of earthing resistance

Earthing resistance of the earth electrode should be measured with current injection method, namely current meter – voltage meter method. Use of portable earthing resistance meters is prohibited. The measurement of earthing resistance can be measured in acceptance tests or in system commissioning or in both.

An external d.c. testing power supply is adopted during acceptance tests, and the earthing current flowing through the earth electrode in monopolar earth return operation mode is utilized during system commissioning.

A current injection loop and a voltage measurement loop are necessary in the test. Usually two electrode lines are used as the current line and potential line respectively during tests for convenience. Manual wiring is also an option.

One end of the current injection loop is connected to the earth electrode directly or through electrode line, and the other is grounded at least 10 km away from the earth electrode, usually connected with the grounding network of the converter station or tower grounding, of which the grounding resistance is typically less than 5.

One end of the voltage measurement loop is connected to the earth electrode at the electrode site, and the other end, called reference pole, is grounded at least 10 km away from the earth electrode. The reference pole should be 10 km away from the current pole to be sure that the potential of the reference pole is about zero. Cu-CuSO₄ reference electrode or Angle steel bars with a size no smaller than 50 × 5 mm² and a length of 1,5 m can be used as the reference pole.

During acceptance tests, the background voltage U_0 between the earth electrode and the reference pole should be measured before measurement with the injected current. The real voltage is obtained by eliminating the background voltage and the earthing resistance, which is the ratio of the real voltage to the injected current. It is usually not conducted during system commissioning.

D.2.4 Measurement of step voltage on the ground and potential gradient in water near the earth electrode

The measurement of step voltage on the ground and potential gradient in water can be measured in acceptance tests or in system commissioning or in both.

A self-contained d.c. power supply or the d.c. system earth electrode earthing current can serve as the power supply for generating ground potential around the earth electrode.

The measurement should be conducted in every location where the step voltage is likely to be high, usually determined by simulation. At the location where the direction of the step voltage is not clear, the measurement should be performed in two directions that are perpendicular to each other so as to achieve the amplitude and direction of the potential gradient through the addition of vectors. The highest measured step voltage and highest potential gradient in water should not exceed the design limit.

Step voltage can be measured either with the potential method or the voltage method. With the potential method, one of a pair of reference electrodes is fixed on the ground surface above the buried earth electrode. The other reference electrode is moved at 1 m interval and the change in potential of the moving electrode is measured as step voltage, using the first reference electrode as the potential reference. With the step voltage method, the distance between the two reference electrodes is fixed to 1 m and both of them are moved simultaneously in the radial direction.

During acceptance tests, the background voltage U_0 between the two electrodes should be measured before measurements with the injected current. The real step voltage is obtained by eliminating the background voltage. The tested results should be multiplied by the scale factor (rated current divided by the total testing current).

The potential difference between the two reference electrodes in a pair should be less than 10 mV. The potential meter should be able to provide effective readings.

D.2.5 Measurement of touch voltage

The measurement of touch voltage can be measured in acceptance tests or during the system commissioning or both.

The touch voltage measurement should be carried out on grounded metal structures near the earth electrode, such as earth electrode current-guiding towers, metal greenhouses and metal water taps. The measured maximum touch voltage should not exceed the design limit.

The touch voltage is measured with a digital multimeter and a reference electrode. During measurement, one of the voltage probes of the multimeter is connected to the metal construction and the other voltage probe is connected to the reference electrode, and the reference electrode is inserted into a point on the ground 1 m horizontally away from the metal construction.

During acceptance tests, the background voltage U_0 should be measured before measurement with the injected current. The real touch voltage is obtained by eliminating the background voltage. The tested results should be multiplied by the scale factor (rated current divided by the total testing current).

In the case of a large metal construction the measurements should be made at different positions to achieve the maximum touch voltage.

D.2.6 Measurement of ground surface potential distribution

Potential rise (curve) is an important characteristic parameter of the earth electrode, which can be used as the basis for evaluating the impact of earth current on the environment. The measurement of touch voltage can be measured in acceptance tests or during system commissioning or both.

The measurement method and measurement requirements are almost same as those in the earthing resistance measurement. The difference is that the voltage probe connected to the earth electrode is fixed during the earthing resistance measurements, whereas it is a moving probe during ground surface potential distribution measurements. The probe moves from the earth electrode to the reference pole to obtain a potential distribution curve.

D.2.7 Measurement of earth electrode temperature rise

If the system allows the current to flow through the earth electrode continuously for a long time during commissioning, the temperature rise of the earth electrode should be measured to evaluate thermal properties of the earth electrode during operation.

During testing, the temperature rise in the earth electrode and surrounding soil should be measured. The measurement should be carried out both before and after energization. Tests before energization should be conducted in the hottest season if possible. In tests after energization, the earthing current should remain constant until the measured temperature reaches a stable level.

At least 6 measurement locations, where the current flowing density or current releasing density is large, should be selected. The measurement of the soil temperature should be on the surface of the backfilled coke column. Given the limitations of site conditions, the maximum measurement depth in soil temperature measurements can be the burial depth of the earth electrode in general.

Temperature is measured in °C with a precision of $\pm 0,5$ °C. Soil temperature should preferably be measured with a portable thermistor thermometer. Or, alternatively, a mercury or alcohol capillothermometer can be adopted for this purpose. If a mercury thermometer is used and placed in a long testing tube, proper measures should be taken to ensure that the thermometer can measure the temperature at the specified depth and will not be affected by a change of ground atmospheric temperature.

Annex E (informative)

Earth electrode electrical parameter calculation method

E.1 General

This annex describes the numerical calculation methods for the electrical parameters of earth electrodes in complicated soil conditions. For a d.c. earth electrode buried in complicated soil conditions, the numerical calculation method is suggested for analysis. The recommended calculation methods include network method, moment method and finite element method. The network method can be used for estimation of simple earth electrode model. The moment method can be used for soil structures in which a horizontal multi-layer model can be created. The finite element method can be used for other complicated situations.

E.2 Network method calculation model for d.c. earth electrode

The earth electrode unit in ground network can be represented by a 'π' shape equivalent circuit formed by unit length of resistance (R_0) and conductance (G_0), as shown in Figure E.1.

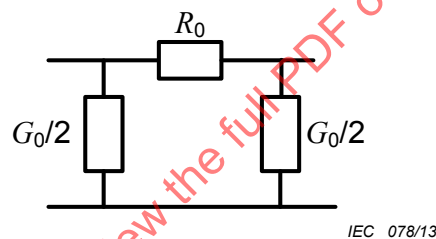

Figure E.1 – π shape equivalent circuit of an individual earth electrode unit

On this basis, an earth electrode can be represented by a network composed of multiple unit earth electrode models as shown in Figure E.1. This means that an earth electrode can be divided into a number of small 'π' shape equivalent circuits, and in this way the earthing resistance of the earth electrode can be achieved by means of external excitation.

The above earth electrode unit models and solutions can be completed with time domain software such as EMTP, etc., which simplifies the calculation.

E.3 Moment method calculation model for d.c. earth electrodes

To find the solution of the constant current field of an earth electrode with the moment method, the leakage currents of conductors are used as the basic variables. The deduction process using leakage current to describe earthing characteristics of d.c. earth electrodes is mainly based on two basic physical laws: the potential continuity law and Ohm's law. With these two laws, the mathematical description of leakage current characteristics can be determined. After the specific presentation of characteristics of earth electrode leakage current has been determined, the earth electrode potential rise and ground potential distribution can be calculated with Green's function in multiple soil layers and mathematical relations.

The specific steps are described below:

- a) apply Ohm's Law to the earth electrode conductor shown in Figure E.2 and perform a linear integration along the conductor axis to achieve Formula (E.1):

$$\begin{aligned} I &= \nu US \\ IR &= U \end{aligned} \tag{E.1}$$

where

- I is the axial current of the conductor,
- S is the conductor cross-section area,
- l is the conductor axial length,
- ν is the medium conductivity,
- R is the d.c. resistance of the earth electrode,
- U is the potential difference of any segment in the conductor;

- b) based on the potential continuity equation, as shown in Figure E.3, build the axial potential difference Equation (E.2) for the internal surface of the conductor and its external surface in contact with the surrounding medium:

$$U^e = U^i \tag{E.2}$$

where

- U^e is the potential of the external surface of the conductor,
- U^i is the potential of the internal surface of the conductor;

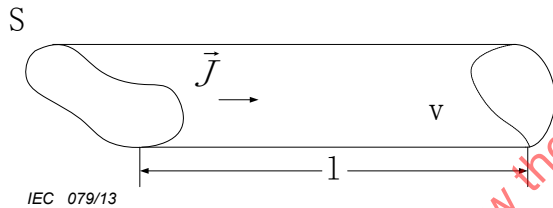

Figure E.2 – Ohm's Law applied to cylinder conductor.

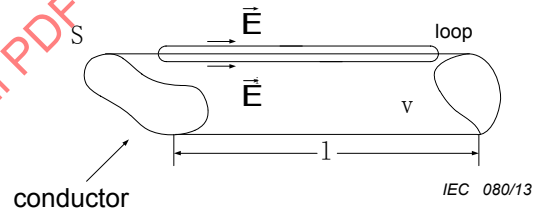

Figure E.3 – Continuity of axial component of the electric field in the soil and in the conductor

- c) express the potential difference inside and outside the conductor as a function of leakage current on the surface of the conductors to construct the equations to be solved.

To describe the earthing characteristics of the earth electrode as a function of leakage current, first divide the earth electrode into several conductor segments in space, as shown in Figure E.4. For any conductor segment, by using the number n conductor as an example, create Equation (E.3) based on potential continuity Equation (E.2).

$$R_n I_n = \sum_m t_{nm} (I_{m-\text{leak}}) \tag{E.3}$$

where

- $I_{m-\text{leak}}$ is the leakage current of the number m conductor segment,
- t_{nm} is the function to associate the leakage current of leakage current of number m conductor and potential difference of outer surface of number n conductor;

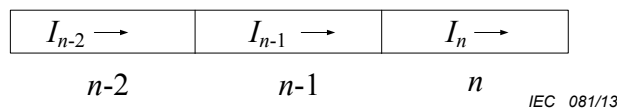

Figure E.4 – Spatial division of the earth electrode

The solution of this function requires the use of point current source Green function in layered soil.

Formula (E.3) can be expressed in a matrix form:

$$RI = t(I_{\text{leak}}) \tag{E.4}$$

where

- R is the diagonal matrix containing elements of axial d.c. resistance of different conductor segments;
- I_{leak} is the leakage current vector of different conductor segments;
- I is the axial current vector of different conductor segments.

For the circuit network formed by grounding network conductors shown in Figure E.5, each conductor segment has only two end points due to spatial division. Assume that the two end points of number n conductor are n^- and n^+ , and $\varphi_n, \varphi_{n-1}, \dots,$ and φ_{n-k} are the middle point potential of number n , number $n-1$, ..., and number $n-k$ conductor segments respectively.

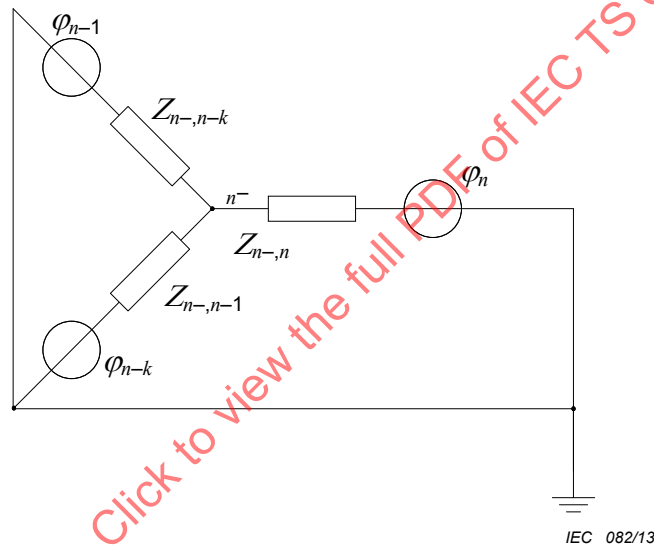

Figure E.5 – Network for solving axis current

- d) use the node voltage method to solve the network and achieve the current I_{n^-} flowing from axis of number n^- node to number n conductor:

$$I_{n^-} = f_{n^-}(R, \varphi) = f_{n^-}(R, I_{\text{leak}}) \tag{E.5}$$

where

- φ is the middle point potential vector of different conductor segments,
- F is the relations between I and R and I_{leak} .

Based on Kirchhoff's current law, the current released from number n conductor to the earth is:

$$I_{n-\text{leak}} = I_{n^-} - I_{n^+} = f_{n^-}(R, I_{\text{leak}}) - f_{n^+}(R, I_{\text{leak}}) \tag{E.6}$$

If any current is injected into number n conductor segment, the relation between axial current and leakage current is:

$$I_{n-\text{leak}} = I_{n^-} - I_{n^+} + I_e = f_{n^-}(R, I_{\text{leak}}) - f_{n^+}(R, I_{\text{leak}}) + I_e \tag{E.7}$$

- e) make the above calculation for different conductor segments to achieve equations for n axial currents and n leakage currents.

$$I = F(R, I_{\text{leak}}, I_e) \tag{E.8}$$

where

- I_e is the excitation vector,
- F is the matrix composed of f ;

- f) put Formula (E.8) into Formula (E.4) to achieve:

$$[R][F(R, I_{\text{leak}}, I_e)] = [I(I_{\text{leak}})] \tag{E.9}$$

- g) solve Formula (E.9) to achieve the distribution of leakage current of the earth electrode. Use Green's function of the layered soil to obtain potential of any spatial point. In this way, the earthing resistance of the earth electrode and ground potential distribution can be easily obtained.

During the deduction of the arithmetical relation concerning the distribution of earth electrode leakage current, one important concept is the potential distribution resulting from the point current source, i.e. Green's function of point current source, as shown in Figure E.6. With the point current source, the potential distribution in layered medium can be expressed below.

In a reactive region:

$$\nabla^2 \phi = 0 \tag{E.10}$$

In an active region:

$$\nabla^2 \phi = -\rho_l I \delta(R - z_0) \tag{E.11}$$

where

- I is the current amplitude of the point current source,
- ρ_l is the resistivity of number l soil,
- δ is the Dirac function,
- R is the field point vector, and
- z_0 is the and source point vector.

The solution of potential function ϕ_l in active layers can be expressed below:

$$\phi_l = \phi_l' + \frac{\rho_l I}{4\pi(R - z_0)} \tag{E.12}$$

The first part (ϕ_l') of Equation (E.12) satisfies the Laplace Equation (E.10) in the reactive region. The second part of Equation (E.12) is a component specific to the active layers.

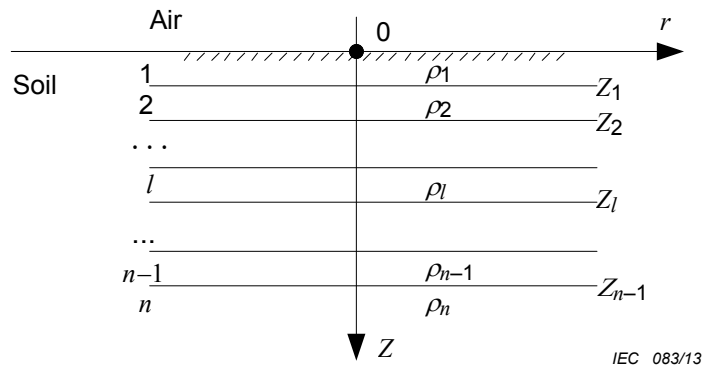

Figure E.6 – Horizontally layered soil

Taking horizontally layered soil as an example, the second part of equation (E.12) can be expressed below using Lipsitzch integration:

$$\frac{\rho_l I}{4\pi |R - z_0|} = \frac{\rho_l I}{4\pi} \int_0^\infty J_0(\lambda r) e^{-\lambda |z - z'|} d\lambda \tag{E.13}$$

where $J_0(\lambda r)$ is a zero-order Bessel function of the first kind.

For reactive layers (number l layer as an example), the potential function expression that satisfies Formula (E.11) is:

$$\phi_l = \frac{I\rho_l}{4\pi} \left[\int_0^\infty \alpha_l'(\lambda) J_0(\lambda r) e^{-\lambda(z-z')} d\lambda + \int_0^\infty \beta_l'(\lambda) J_0(\lambda r) e^{\lambda(z-z')} d\lambda \right] \tag{E.14}$$

where α_l' and β_l' are coefficients to be determined.

The potential layers (number l layer as an example) is:

$$\phi_l = \frac{I\rho_l}{4\pi} \int_0^\infty J_0(\lambda r) e^{-\lambda |z - z'|} d\lambda + \frac{I\rho_l}{4\pi} \int_0^\infty \alpha_l'(\lambda) J_0(\lambda r) e^{-\lambda(z-z')} d\lambda + \frac{I\rho_l}{4\pi} \int_0^\infty \beta_l'(\lambda) J_0(\lambda r) e^{\lambda(z-z')} d\lambda \tag{E.15}$$

α_l' and β_l' in Equation (E.14) and Equation (E.15) are coefficients to be determined. The solution of these equations requires boundary conditions of soil layers. For a conductive medium with a structure of n layers of soil, the boundary conditions of soil layers are described below:

$$\begin{aligned} \varphi_1 &= \varphi_2, \frac{1}{\rho_1} \frac{\partial \varphi_1}{\partial z} = \frac{1}{\rho_2} \frac{\partial \varphi_2}{\partial z}, z = z_1 \\ &\dots\dots \\ \varphi_2 &= \varphi_3, \frac{1}{\rho_2} \frac{\partial \varphi_2}{\partial z} = \frac{1}{\rho_3} \frac{\partial \varphi_3}{\partial z}, z = z_2 \\ &\dots\dots \\ \varphi_i &= \varphi_{i+1}, \frac{1}{\rho_i} \frac{\partial \varphi_i}{\partial z} = \frac{1}{\rho_{i+1}} \frac{\partial \varphi_{i+1}}{\partial z}, z = z_i \quad (E.16) \\ &\dots\dots \\ \varphi_{n-1} &= \varphi_n, \frac{1}{\rho_{n-1}} \frac{\partial \varphi_{n-1}}{\partial z} = \frac{1}{\rho_n} \frac{\partial \varphi_n}{\partial z}, z = z_{n-1} \end{aligned}$$

$$\begin{aligned} \frac{\partial \phi_1}{\partial z} &= 0, z = 0 \\ \phi_n &= 0, z = \infty \end{aligned} \quad (E.17)$$

h) put Equations (E.16) and (E.17) into boundary conditions of different soil layers to obtain the expression for coefficients α_i' and β_i' .

E.4 Finite element method calculation model for d.c. earth electrodes

For complicated soil models in which Green’s function cannot be determined, the finite element method is required for calculation and analysis. Assume that V represents the solution domain of the earth electrode current field, and S is the boundary. The potential distribution within the field domain can be expressed as $\varphi(x,y,z)$. To solve this model using the finite element method, first, divide the soil domain V (field domain) containing the earth electrode into several regular units. Tetrahedron units are typically used for the division of the domain V , and the boundary S is substituted by triangles. Define e as the index number of the tetrahedron units. Suppose the total number of tetrahedron units is M , then $e = 1, 2, \dots, M$. The vertices of number e units are called nodes, and are represented by the numbers 1, 2, 3, and 4, as shown in Figure E.7.

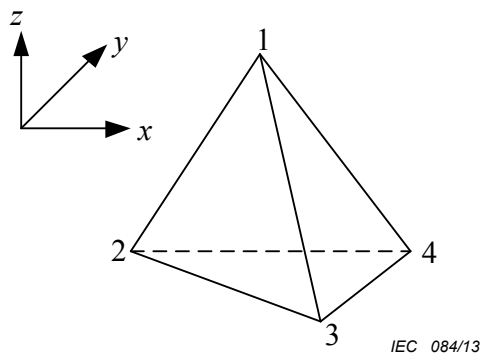

Figure E.7 – Geometrical structure of a tetrahedron unit

After the division of the field domain V , based on the principle of minimum potential energy, in Cartesian coordinates, the variation expression describing the d.c. current field in unit e can be written as:

$$F(\varphi^e) = -\int_V \gamma^e \left\{ \left(\frac{\partial \varphi^e}{\partial x} \right)^2 + \left(\frac{\partial \varphi^e}{\partial y} \right)^2 + \left(\frac{\partial \varphi^e}{\partial z} \right)^2 + \varphi^e J_V \right\} dV - 2 \int_{S_2} \varphi^e J_{s2} dS \quad (\text{E.18})$$

where

- S is the current density on the given face,
- J_{s2} is the second type boundary face, and
- J_V is the body current density.

The field distribution characteristics $\varphi(x,y,z)$ within unit e can be expressed with known polynomial $\varphi^e(x,y,z)$ approximately as:

$$\varphi^e(x,y,z) = N_1^e \varphi_1^e + N_2^e \varphi_2^e + N_3^e \varphi_3^e + N_4^e \varphi_4^e \quad (\text{E.19})$$

where $N_i^e (i=1,2,3,4)$ is the shape function of the tetrahedron, which is expressed as:

$$N_i^e(x,y,z) = \frac{1}{6\Delta} (a_i^e + b_i^e x + c_i^e y + d_i^e z), \quad (i=1,2,3,4) \quad (\text{E.20})$$

where Δ , as determined below, is the volume of unit e , and the coefficients $a_i^e, b_i^e, c_i^e, d_i^e$ ($i=1,2,3,4$) are determined based on the node coordinates.

$$\Delta = \frac{1}{6} \begin{vmatrix} 1 & 1 & 1 & 1 \\ x_1^e & x_2^e & x_3^e & x_4^e \\ y_1^e & y_2^e & y_3^e & y_4^e \\ z_1^e & z_2^e & z_3^e & z_4^e \end{vmatrix}$$

The approximate field distribution of the tetrahedron $\varphi^e(x,y,z)$ can therefore be achieved and expressed as the following matrix:

$$\varphi^e(x,y,z) = [N_1^e, N_2^e, N_3^e, N_4^e] \begin{Bmatrix} \varphi_1^e \\ \varphi_2^e \\ \varphi_3^e \\ \varphi_4^e \end{Bmatrix} = [N]_e \{\varphi\}_e \quad (\text{E.21})$$

Substitute the interpolation function $\varphi^e(x,y,z)$ into the variation Equation (E.18) describing unit e , and use the minimum first variation conditions to achieve Formula (E.22):

$$\begin{aligned} \frac{\partial F(\varphi^e)}{\partial \varphi_i^e} &= 0 \\ &= -\sum_{j=1}^4 \int_{V^e} \gamma^e \left\{ \frac{\partial N_i^e}{\partial x} \frac{\partial N_j^e}{\partial x} + \frac{\partial N_i^e}{\partial y} \frac{\partial N_j^e}{\partial y} + \frac{\partial N_i^e}{\partial z} \frac{\partial N_j^e}{\partial z} + N_j^e J_V \right\} \varphi_j^e dV \\ &\quad - 2 \int_{S_2^e} N_i^e J_{s2} dS \end{aligned} \quad (\text{E.22})$$

which can be expressed as a matrix: