**Information technology — Data
interchange on 120 mm and 80 mm
optical disk using +R DL format —
Capacity: 8,55 Gbytes and 2,66 Gbytes
per side (recording speed up to 8x)**

*Technologies de l'information — Échange de données sur disque
optique de 120 mm et 80 mm utilisant le format +R DL — Capacité:
8,55 Go et 2,66 Go par face (vitesse d'enregistrement 8x)*

IECNORM.COM : Click to view the full PDF of ISO/IEC 25434:2007

PDF disclaimer

This PDF file may contain embedded typefaces. In accordance with Adobe's licensing policy, this file may be printed or viewed but shall not be edited unless the typefaces which are embedded are licensed to and installed on the computer performing the editing. In downloading this file, parties accept therein the responsibility of not infringing Adobe's licensing policy. The ISO Central Secretariat accepts no liability in this area.

Adobe is a trademark of Adobe Systems Incorporated.

Details of the software products used to create this PDF file can be found in the General Info relative to the file; the PDF-creation parameters were optimized for printing. Every care has been taken to ensure that the file is suitable for use by ISO member bodies. In the unlikely event that a problem relating to it is found, please inform the Central Secretariat at the address given below.

IECNORM.COM : Click to view the full PDF of ISO/IEC 25434:2007



COPYRIGHT PROTECTED DOCUMENT

© ISO/IEC 2007

All rights reserved. Unless otherwise specified, no part of this publication may be reproduced or utilized in any form or by any means, electronic or mechanical, including photocopying and microfilm, without permission in writing from either ISO at the address below or ISO's member body in the country of the requester.

ISO copyright office
Case postale 56 • CH-1211 Geneva 20
Tel. + 41 22 749 01 11
Fax + 41 22 749 09 47
E-mail copyright@iso.org
Web www.iso.org

Published in Switzerland

Contents

Page

Foreword.....	vii
Introduction	viii
Section 1 - General	1
1 Scope	1
2 Conformance	1
2.1 Optical disk.....	1
2.2 Generating system.....	2
2.3 Receiving system.....	2
2.4 Compatibility statement	2
3 Normative references	2
4 Terms and definitions.....	2
5 Conventions and notations	5
5.1 Representation of numbers	5
5.2 Names	5
6 Abbreviations and acronyms	6
7 General description of the optical disk	6
8 General Requirements.....	7
8.1 Environments	7
8.2 Safety requirements	8
8.3 Flammability	8
8.4 Light fastness.....	8
9 Reference Drive.....	9
9.1 Optical system	9
9.2 Optical beam	9
9.3 Read channel 1.....	10
9.4 Disk clamping.....	10
9.5 Rotation of the disk	11
9.6 Wobble channel (Read channel 2)	11
9.7 Tracking channel (Read channel 2)	11
9.8 Reference servo systems	11
Section 2 - Dimensional, mechanical and physical characteristics of the disk.....	14
10 Dimensional characteristics	14
10.1 Reference Planes	15
10.2 Overall dimensions.....	16
10.3 First transition area	16
10.4 Second transition area	17
10.5 Clamping Zone	17
10.6 Third transition area	17
10.7 Information Zone.....	17
10.8 Rim area.....	19
10.9 Remark on tolerances	19
11 Mechanical characteristics	19
11.1 Mass	19
11.2 Moment of inertia	19
11.3 Dynamic imbalance	19

11.4	Axial runout	19
11.5	Radial runout	20
12	Optical characteristics in the Information Zone	21
12.1	Index of refraction	21
12.2	Thickness of the substrate.....	21
12.3	Reflectivity	22
12.4	Birefringence	22
12.5	Angular deviation	22
Section 3 - Format of information.....		23
13	Data format	23
13.1	Data Frames.....	23
13.2	Scrambled Frames	26
13.3	ECC Blocks	26
13.4	Recording Frames.....	28
13.5	Modulation and NRZI conversion	28
13.6	Physical Sectors	29
13.7	Layout of a Recording UNIT (RUN).....	30
13.8	d.c. component suppression control.....	31
14	Track format.....	32
14.1	Track shape	32
14.2	Track path	33
14.3	Track pitch	33
14.4	Track layout	33
Section 4 - Format of the Information Zone		56
15	General description of the Information Zone	56
16	Layout of the Information Zone of a Single-session disk.....	56
16.1	Usage of the Data Zone	58
16.2	Physical Sector Numbers (PSNs).....	60
17	Inner Drive Areas	61
17.1	Initial Zone / Final Zone	61
17.2	Inner Disk Test Zones	62
17.3	Count Zone Run-in / Dummy Zone.....	62
17.4	Inner Disk Count Zones	62
17.5	Inner Disk Administration Zone.....	62
17.6	Table of Contents (TOC) Zone	63
18	Lead-in Zone	68
18.1	Guard Zone 1	69
18.2	Reserved Zone 1	69
18.3	Reserved Zone 2	69
18.4	Inner Disk Identification Zone.....	69
18.5	Reserved Zone 3	69
18.6	Reference Code Zone	70
18.7	Buffer Zone 1	70
18.8	Control Data Zone	70
18.9	Buffer Zone 2	73
19	Data Zone	73
20	Middle Zones	73
20.1	Buffer Zones 3	75
20.2	Reserved Zones	75
20.3	Guard Zones 2	75
21	Outer Drive Areas.....	75
21.1	Outer Disk Administration Zones.....	75
21.2	Outer Disk Count Zones	76
21.3	Dummy Zone / Count Zone Run-in.....	77

21.4	Outer Disk Test Zone.....	77
21.5	Guard Zones 3.....	77
22	Lead-out Zone	77
22.1	Lead-out Zone at finalization.....	77
22.2	Lead-out Zone at closing of first Session	78
23	Multi-session Layout	79
23.1	Intro	80
23.2	Data Zone.....	80
23.3	Closure.....	80
24	Sequential recording in Fragments	81
24.1	Opening a Session.....	81
24.2	Closing a Session	83
24.3	Finalizing the disk.....	84
25	Assignment of Logical Sector Numbers (LSNs).....	84
26	Disk Control Blocks.....	84
26.1	General format of Disk Control Blocks.....	85
26.2	Format of the Session DCB (SDCB).....	86
Section 5 - Characteristics of the groove.....		90
27	General.....	90
28	Method of testing	91
28.1	Environment	91
28.2	Reference Drive.....	91
28.3	Definition of signals.....	91
29	Characteristics of the groove signals.....	92
29.1	Phase depth.....	92
29.2	Push-pull signal	92
29.3	Track Cross signal.....	93
29.4	Normalized wobble signal.....	93
29.5	Characteristics of the wobble.....	93
Section 6 - Characteristics of the recording layer.....		94
30	Method of testing	94
30.1	Environment	94
30.2	Reference Drive.....	94
30.3	Write conditions.....	95
30.4	Measurement conditions	97
31	Characteristics of the recorded signals	97
31.1	Channel bit length.....	97
31.2	Definition of signals.....	97
31.3	Read stability.....	99
32	Additional testing conditions	99
32.1	Test environment.....	99
32.2	Definition of signals.....	100
33	Quality of the recording layer	102
33.1	Defects	102
33.2	Data errors.....	102
Section 7 - Characteristics of user data		103
34	Method of testing	103
34.1	Environment	103
34.2	Reference Drive.....	103
35	Minimum quality of a Recording Unit	104
35.1	Tracking	104
35.2	User-written data.....	104

Annex A (normative) 80 mm +R DL disk	105
Annex B (normative) Structure for Extended format information in the Data Zone	109
Annex C (normative) Measurement of light reflectivity	112
Annex D (normative) Measurement of birefringence	114
Annex E (normative) Measuring conditions for operation signals	117
Annex F (normative) Measurement of the differential phase tracking error	120
Annex G (normative) The write pulse wave form for testing	124
Annex H (normative) 8-to-16 Modulation	129
Annex I (normative) Optimum Power Control and Recording Conditions	137
Annex J (informative) Running OPC	140
Annex K (informative) Wavelength dependency	141
Annex L (informative) Explanation about the usage of the reference servos	146
Annex M (informative) Measurement of the groove wobble amplitude	151
Annex N (informative) Light fastness of the disk	153
Annex O (informative) Transportation	154
Annex P (informative) Video Content Protection System	155
Annex Q (informative) How to use the Physical format information in ADIP	156
Annex R (informative) Values to be Implemented in Existing and Future Specifications	158

IECNORM.COM : Click to view the full PDF of ISO/IEC 25434:2007

Foreword

ISO (the International Organization for Standardization) and IEC (the International Electrotechnical Commission) form the specialized system for worldwide standardization. National bodies that are members of ISO or IEC participate in the development of International Standards through technical committees established by the respective organization to deal with particular fields of technical activity. ISO and IEC technical committees collaborate in fields of mutual interest. Other international organizations, governmental and non-governmental, in liaison with ISO and IEC, also take part in the work. In the field of information technology, ISO and IEC have established a joint technical committee, ISO/IEC JTC 1.

International Standards are drafted in accordance with the rules given in the ISO/IEC Directives, Part 2.

The main task of the joint technical committee is to prepare International Standards. Draft International Standards adopted by the joint technical committee are circulated to national bodies for voting. Publication as an International Standard requires approval by at least 75 % of the national bodies casting a vote.

Attention is drawn to the possibility that some of the elements of this document may be the subject of patent rights. ISO and IEC shall not be held responsible for identifying any or all such patent rights.

ISO/IEC 25434 was prepared by Ecma International (as ECMA-364) and was adopted, under a special "fast-track procedure", by Joint Technical Committee ISO/IEC JTC 1, *Information technology*, in parallel with its approval by national bodies of ISO and IEC.

This second edition cancels and replaces the first edition (ISO/IEC 25434:2006), which has been technically revised.

Introduction

Ecma Technical Committee TC 31 was established in 1984 for the standardization of Optical Disks and Optical Disk Cartridges (ODC). Since its establishment, the Committee has made major contributions to ISO/IEC toward the development of International Standards for 80 mm, 90 mm, 120 mm, 300 mm and 356 mm media. Numerous standards have been developed by TC 31 and published by Ecma, almost all of which have also been adopted by ISO/IEC under the fast-track procedure as International Standards.

In July 2004 a group of Companies proposed to TC 31 to develop a standard for 120 mm dual layer recordable optical disks using the WORM recording technology and based on the DVD – Read-Only standard (ISO/IEC 16448), the +RW format (ISO/IEC 17341) and the +R format (ISO/IEC 17344). TC 31 adopted this project and started the work that has resulted in the adoption of ISO/IEC 25434.

This International Standard specifies two Types of recordable optical disks, one (Type S9) making use of recording on only a single side of the disk and yielding a nominal capacity of 8,55 or 2,66 Gbytes per disk and the other (Type D18) making use of recording on both sides of the disk and yielding a nominal capacity of 17,1 or 5,32 Gbytes per disk.

In October 2005 a proposal was made to TC 31 to update this International standard for recording speeds up to 8 times the Reference velocity. TC 31 adopted this project which resulted in the adoption of ISO/IEC 25434 2nd Edition.

This International Standard, taken together with a standard for volume and file structure, such as for instance developed in Ecma Technical Committee TC 15, provides the requirements for information interchange between systems.

IECNORM.COM : Click to view the full PDF of ISO/IEC 25434:2007

Information technology — Data interchange on 120 mm and 80 mm optical disk using +R DL format — Capacity: 8,55 Gbytes and 2,66 Gbytes per side (recording speed up to 8x)

Section 1 - General

1 Scope

This International Standard specifies the mechanical, physical and optical characteristics of 120 mm recordable optical disks with capacities of 8,55 Gbytes and 17,1 Gbytes. It specifies the quality of the recorded and unrecorded signals, the format of the data and the recording method, thereby allowing for information interchange by means of such disks. The data can be written once and read many times using a non-reversible method. These disks are identified as +R DL.

This International Standard also specifies 80 mm disks with capacities of 2,66 Gbytes and 5,32 Gbytes. These disks have the same characteristics as the 120 mm disks, except for some parameters related to the smaller dimensions. All parameters unique for the 80 mm disks are specified in Annex A.

This International Standard specifies

- two related but different Types of this disk (see Clause 7),
- the conditions for conformance,
- the environments in which the disk is to be tested, operated and stored,
- the mechanical, physical and dimensional characteristics of the disk, so as to provide mechanical interchange between data processing systems,
- the format of the information on the disk, including the physical disposition of the tracks and sectors, the error correcting codes and the coding method,
- the characteristics of the signals recorded on the disk, thus enabling data processing systems to read the data from the disk.

This International Standard provides for the interchange of disks between optical disk drives. Together with a standard for volume and file structure, it provides for full data interchange between data processing systems.

2 Conformance

2.1 Optical disk

A claim of conformance with this International Standard shall specify the Type implemented. An optical disk shall be in conformance with this International Standard if it meets all mandatory requirements specified for its Type.

2.2 Generating system

A generating system shall be in conformance with this International Standard if the optical disk it generates is in accordance with 2.1.

2.3 Receiving system

A receiving system shall be in conformance with this International Standard if it is able to handle both Types of optical disk according to 2.1.

2.4 Compatibility statement

A claim of conformance by a Generating or Receiving system with this International Standard shall include a statement listing any other standards supported. This statement shall specify the numbers of the standards, the optical disk types supported (where appropriate) and whether support includes reading, only or both reading and writing.

3 Normative references

The following referenced documents are indispensable for the application of this document. For dated references, only the edition cited applies. For undated references, the latest edition of the referenced document (including any amendments) applies.

ISO 4873:1991, *Information technology — ISO 8-bit code for information interchange — Structure and rules for implementation*

ISO 16448:2002, *Information technology — 120 mm DVD — Read-only disk*

ISO 16449:2002, *Information technology — 80 mm DVD — Read-only disk*

ISO 17341:2006, *Information technology — Data Interchange on 120 mm and 80 mm Optical Disk using +RW Format — Capacity: 4,7 Gbytes and 1,46 Gbytes per Side (Recording speed up to 4X)*

ISO 17344:2006, *Information technology — Data Interchange on 120 mm and 80 mm Optical Disk using +R Format — Capacity: 4,7 and 1,46 Gbytes per Side (Recording speed up to 16X)*

ISO 26925:2006, *Information technology — Digital storage media for information interchange — Data Interchange on 120 mm and 80 mm Optical Disk using +RW HS Format — Capacity: 4,7 and 1,46 Gbytes per Side (Recording speed 8X)*

ECMA-287 (2002), *Safety of electronic equipment*

4 Terms and definitions

For the purpose of this document, the following terms and definitions apply.

4.1 Channel bit
the elements by which the binary values ZERO and ONE are represented by marks and spaces on the disk

4.2 Clamping Zone
the annular part of the disk within which the clamping force is applied by the clamping device

4.3**Digital Sum Value (DSV)**

the arithmetic sum obtained from a bit stream by allocating the decimal value +1 to bits set to ONE and the decimal value -1 to bits set to ZERO

4.4**Disk Reference Plane**

a plane defined by the perfectly flat annular surface of an ideal spindle onto which the clamping Zone of the disk is clamped, and which is normal to the axis of rotation

4.5**dummy substrate**

a layer, which may be transparent or not, provided for the mechanical support of the disk and, in some cases, of the recording layer as well

4.6**entrance surface**

the surface of the disk onto which the optical beam first impinges

4.7**field**

a subdivision of a sector

4.8**groove**

a trench-like feature of the disk, applied before the recording of any information and used to define the track location

NOTE The groove is located nearer to the entrance surface than the so-called land in between the grooves. The recording is made on the groove.

4.9**interleaving**

the process of reallocating the physical sequence of units of data so as to render the data more immune to burst errors

4.10**layer structure**

dual layer DVD discs generally are constructed according to one of the following two structures:

“2P” structure: in this method the first recording layer (L0) is applied to the substrate with the impressed pre-groove, after which the recording layer is covered with a semi-transparent mirror. On top of this structure a spacer layer is applied, which in general consists of a Photo-Polymerisation (2P) lacquer, in which the pre-groove for the second layer is impressed and fixated by means of UV-light. Next the second recording layer (L1) and a mirror are applied. Finally the dummy substrate is glued onto this structure.

“inverted-stack” structure: in this method the first recording layer (L0) is applied to the substrate with the impressed pre-groove, after which the recording layer is covered with a semi-transparent mirror. The dummy substrate with the impressed pre-groove for the second layer is covered with the mirror after which the recording layer (L1) is applied. Next the two substrates are glued together, separated by a spacer.

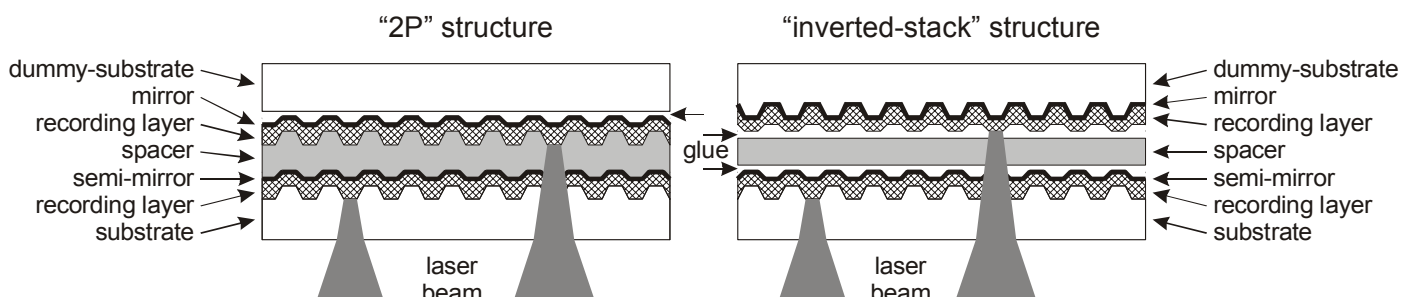

4.11

mark

a non-reversible feature of the recording layer which may take the form of less reflective area, a pit, or any other type or form that can be sensed by the optical system

NOTE The pattern of marks and spaces represents the data on the disk.

4.12

Multi-session disk

a disk containing more than one set of Lead-in/Intro, Data, and Lead-out/Closure Zones

4.13

Physical Sector

the smallest addressable part of a track in the Information Zone of a disk that can be accessed independently of other addressable parts of the Zone

4.14

recording layer

a layer of the disk on which data is written during manufacture and/or use

4.15

Reed-Solomon code (RS)

an error detection and/or correction code

4.16

Reference velocity

the linear velocity that results in the nominal Channel bit rate of 26 156 25 Mbit/s

4.17

Single-session disk

a disk containing a Lead-in Zone, one Data Zone and a Lead-out Zone

4.18

session

a continuous part of the Information Zone of the disk consisting of a Lead-in or Intro Zone, a Data Zone and a Lead-out or Closure Zone

4.19

space

a feature of the recording layer represented by any area between two marks which can be sensed by the optical system

NOTE The pattern of marks and spaces represents the data on the disk.

4.20

spacer

a transparent layer of the disk, provided for achieving an accurate separation of the pair of recording layers which are accessed by the optical beam through the same entrance surface

4.21

substrate

a transparent layer of the disk, provided for mechanical support of the recording layer, through which the optical beam accesses the recording layer

4.22

track

a 360° turn of a continuous spiral

4.23**track pitch**

the distance between adjacent track centrelines, measured in a radial direction

4.24**VCPS**

Video Content Protection System

a method to prevent unauthorized copying and/or redistribution of video data that is recorded in the DVD+R/+RW Video Format

NOTE See Annex P.

4.25**wobble**

a continuous sinusoidal deviation of the track from the average centreline

NOTE Location information is included as phase modulated data in the wobble.

4.26**zone**

an annular area of the disk

5 Conventions and notations**5.1 Representation of numbers**

A measured value may be rounded off to the least significant digit of the corresponding specified value. For instance, it implies that a specified value of 1,26 with a positive tolerance of + 0,01 and a negative tolerance of – 0,02 allows a range of measured values from 1,235 to 1,274.

Numbers in decimal notations are represented by the digits 0 to 9.

Numbers in hexadecimal notation are represented by the hexadecimal digits 0 to 9 and A to F in parentheses.

The setting of bits is denoted by ZERO and ONE.

Numbers in binary notations and bit patterns are represented by strings of digits 0 and 1, with the most significant bit shown to the left. In a pattern of n bits, bit b_{n-1} shall be the most significant bit (msb) and bit b_0 shall be the least significant bit (lsb). Bit b_{n-1} shall be recorded first.

Negative values of numbers in binary notation are given as Two's complement.

In each data field, the data is recorded so that the most significant byte (MSB), identified as Byte 0, shall be recorded first and the least significant byte (LSB) last.

In a field of $8n$ bits, bit $b_{(8n-1)}$ shall be the most significant bit (msb) and bit b_0 the least significant bit (lsb). Bit $b_{(8n-1)}$ shall be recorded first.

5.2 Names

The names of entities, e.g. specific tracks, fields, etc., are given with an initial capital.

6 Abbreviations and acronyms

a.c.	alternating current	NRZ	Non Return to Zero
ADIP	Address in Pre-groove	NRZI	Non Return to Zero Inverted
ASM	Asymmetry	NSL	Normalized Slicing Level
BP	Byte Position	NWPW	Normalized Write Power Window
BPF	Band Pass Filter	OPC	Optimum Power Control
CAV	Constant Angular Velocity	OTP	Opposite Track Path
CLD	Constant Linear Density	PAA	Physical Address in ADIP
CLV	Constant Linear Velocity	PBS	Polarizing Beam Splitter
cm	current mark	PI	Parity of Inner-code
d.c.	direct current	PLL	Phase Locked Loop
DCB	Disk Control Block	PO	Parity of Outer-code
DCC	d.c. component suppression Control	PP	Push-Pull
DSV	Digital Sum Value	pp	peak-to-peak
ECC	Error Correction Code	ps	previous space
EDC	Error Detection Code	PSN	Physical Sector Number
EI	Extended Information	PTP	Parallel Track Path
HF	High Frequency	RIN	Relative Intensity Noise
ID	Identification Data	RPM	Revolutions per Minute
IED	ID Error Detection code	RS	Reed-Solomon code
LPF	Low Pass filter	RSV	Reserved
LSB	Least Significant Byte		(in use by specific applications)
lsb	Least Significant Bit	RUN	Recording UNit
LSN	Logical Sector Number	SDCB	Session DCB
MSB	Most Significant Byte	SNR	Signal to Noise Ratio
msb	Most Significant Bit	SYNC	Synchronization code
NA	Numerical Aperture	TOC	Table of Contents

7 General description of the optical disk

The optical disk that is the subject of this Standard consists of two substrates bonded together by an adhesive layer, so that the recording layer(s) is (are) on the inside. The centring of the disk is performed on the edge of the centre hole of the assembled disk on the side currently accessed. Clamping is performed in the Clamping Zone. This Standard provides for two Types of such disks.

Type S9 consists of a substrate, a dummy substrate and two recording layers with a spacer between them. Both recording layers can be accessed from one side only. The capacity is 8,55 Gbytes for the 120 mm sized disk and 2,66 Gbytes for the 80 mm sized disk.

Type D18 consists of two substrates, each having two recording layers with a spacer between those two recording layers. From each side of the disk only one pair of recording layers can be accessed. The capacity is 17,1 Gbytes for the 120 mm sized disk and 5,32 Gbytes for the 80 mm sized disk.

Data can be written onto the disk as marks in the form of low-reflective spots in each of the recording layers with a focused optical beam. The data can be read with a focused optical beam, using the difference in the reflectivity between recorded marks and unrecorded spaces.

Figure 1 shows schematically the two Types. The two layers forming a pair of recording layers that can be accessed from one side of the disk, are identified as Layer 0 (L0) and Layer 1 (L1). Layer 0 is the layer nearer to the entrance surface.

The beam accesses Layer 0 through a transparent substrate of the disk.

Layer 1 is accessed through the same transparent substrate, through Layer 0, which for this purpose has to be semi-transparent, and through a transparent spacer.

In the Type S9 disk the function of the adhesive layer can be provided by the spacer between the two recording layers, where Layer 1 is placed on the dummy substrate.

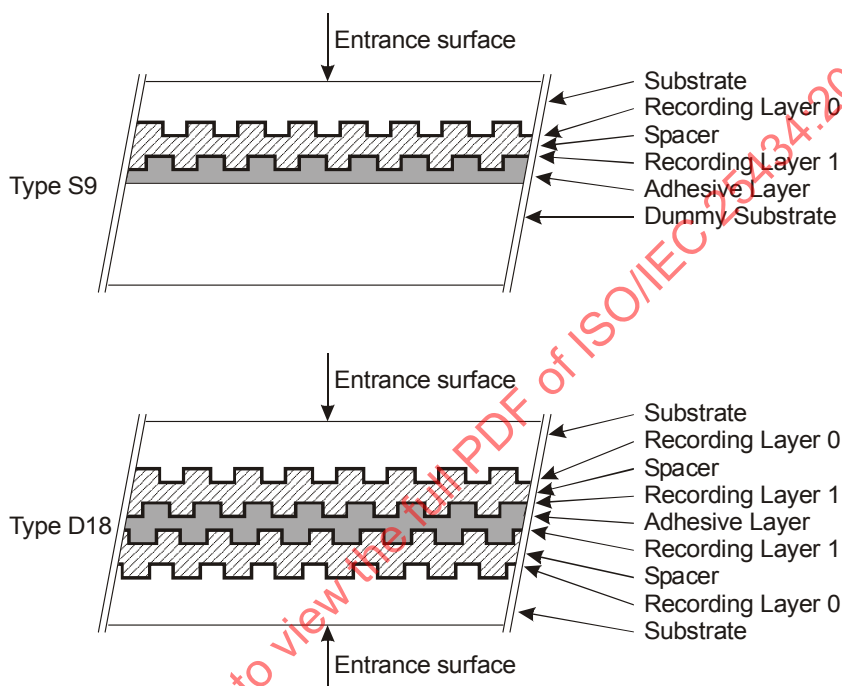

Figure 1 — Types of +R DL disk

8 General Requirements

8.1 Environments

8.1.1 Test environment

In the test environment, the air immediately surrounding the disk shall have the following properties:

temperature	: 23 °C ± 2 °C
relative humidity	: 45 % to 55 %
atmospheric pressure	: 60 kPa to 106 kPa

No condensation on the disk shall occur. Before testing, the disk shall be conditioned in this environment for 48 h minimum. It is recommended that, before testing, the entrance surface of the disk shall be cleaned according to the instructions of the manufacturer of the disk.

Unless otherwise stated, all tests and measurements shall be made in this test environment.

8.1.2 Operating environment

This Standard requires that a disk which meets all requirements of this Standard in the specified test environment shall provide data interchange over the specified ranges of environmental parameters in the operating environment.

The operating environment is the environment where the air immediately surrounding the disk shall have the following properties:

temperature	: 5 °C to 55 °C
relative humidity	: 3 % to 85 %
absolute humidity	: 1 g/m ³ to 30 g/m ³
atmospheric pressure	: 60 kPa to 106 kPa
temperature gradient	: 10 °C/h max.
relative humidity gradient	: 10 %/h max.

No condensation on the disk shall occur. If the disk has been exposed to conditions outside those specified in this clause, it shall be acclimatized in an allowed operating environment for at least 2 h before use.

8.1.3 Storage environment

The storage environment is defined as the environment where the air immediately surrounding the disk shall have the following properties:

temperature	: -10 °C to 55 °C
relative humidity	: 3 % to 90 %
absolute humidity	: 1 g/m ³ to 30 g/m ³
atmospheric pressure	: 60 kPa to 106 kPa
temperature gradient	: 15 °C/h max.
relative humidity gradient	: 10 %/h max.

No condensation on the disk shall occur.

8.1.4 Transportation

This Standard does not specify requirements for transportation; guidance is given in Annex O.

8.2 Safety requirements

The disk shall satisfy the safety requirements of Standard ECMA-287, when used in the intended manner or in any foreseeable use in an information processing system.

8.3 Flammability

The disk and its components shall be made from materials that comply with the flammability class for HB materials, or better, as specified in Standard ECMA-287.

8.4 Light fastness

The disk and its components should be made from materials that are able to withstand a certain amount of light. A method of testing such light fastness is given in Annex N.

9 Reference Drive

The Reference Drive shall be used for the measurement of optical parameters for conformance with the requirements of this Standard. The critical components of this device have the characteristics specified in this clause.

9.1 Optical system

The basic set-up of the optical system of the Reference Drive used for measuring the write and read parameters is shown in Figure 2. Different components and locations of components are permitted, provided that the performance remains the same as that of the set-up in Figure 2.

The optical system shall be such that the detected light reflected from the entrance surface of the disk is minimized so as not to influence the accuracy of the measurements.

The combination of the polarizing beam splitter C and the quarter-wave plate D shall separate the entrance optical beam from the laser diode A and the reflected optical beam from the optical disk F. The beam splitter C shall have a p-s intensity reflectance ratio of at least 100.

During measurements on one layer of a dual-layer disk, light reflected from the other layer can influence the measurements on the layer under investigation. To cope with these effects, the photo detector shall have limited dimensions. Its length and width shall be between $M \times 9 \mu\text{m}$ and $M \times 12 \mu\text{m}$, where M is the transversal optical magnification from the disk to its conjugate plane near the quadrant photo detector G.

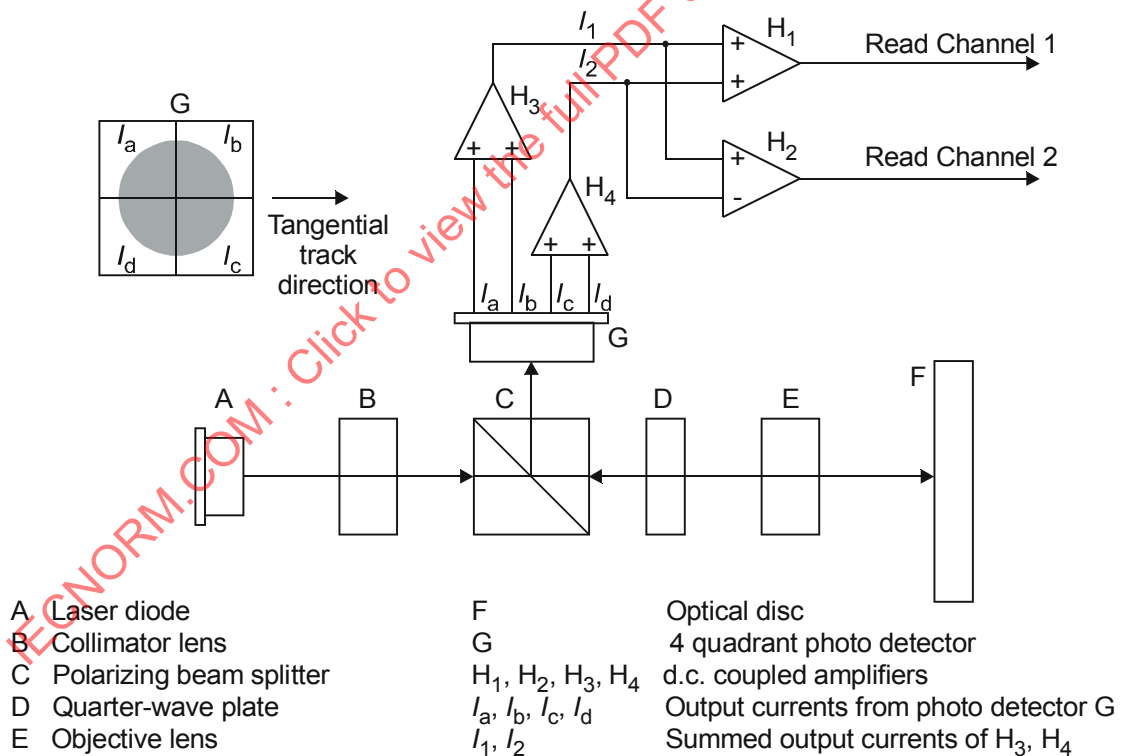

Figure 2 — Optical system of the Reference Drive

9.2 Optical beam

The focused optical beam used for writing and reading data shall have the following properties:

- a) Wavelength (λ) $655 \text{ nm} \begin{matrix} +10 \text{ nm} \\ -5 \text{ nm} \end{matrix}$ (see Annex K)

- b) Numerical aperture of the objective lens (NA) $0,65 \pm 0,01$
- c) The objective lens shall be compensated for spherical aberrations caused by a parallel substrate with nominal thickness (0,6 mm) and nominal refractive index (1,55).
- d) Wave front aberration $0,033 \times \lambda$ rms max.
- e) Light intensity at the rim of the pupil of the objective lens 35 % to 50 % of the maximum intensity in the radial direction and 45 % to 60 % in the tangential direction.
- f) Polarization of the light Circular
- g) Normalized detector size $80 \mu\text{m}^2 \leq S / M^2 \leq 144 \mu\text{m}^2$
where S is the total surface of the quadrant photo detector
- h) Read power (average) $0,7 \text{ mW} \pm 0,1 \text{ mW}$
(d.c. or HF modulated with a frequency >400 MHz)
- i) Write power and pulse width see Annex G
- j) Relative Intensity Noise (RIN)* of the laser diode -134 dB/Hz max.
*RIN (dB/Hz) = $10 \log [(a.c. \text{ light power density} / \text{Hz}) / \text{d.c. light power}]$

9.3 Read channel 1

Read channel 1 shall be provided to generate signals from the marks and spaces in the recording layer. This Read channel shall be used for reading the user-written information, using the change in reflectivity of the marks and spaces. The read amplifiers after the photo detectors in the Read channel shall have a flat response within 1 dB from d.c. to 20 MHz.

For measurement of jitter, the characteristics of the PLL and the slicer, etc. are specified in Annex E.

9.4 Disk clamping

For measuring, the disk shall be clamped between two concentric rings covering most of the Clamping Zone (see 10.5). The top clamping area shall have the same diameters as the bottom clamping area (Figure 3).

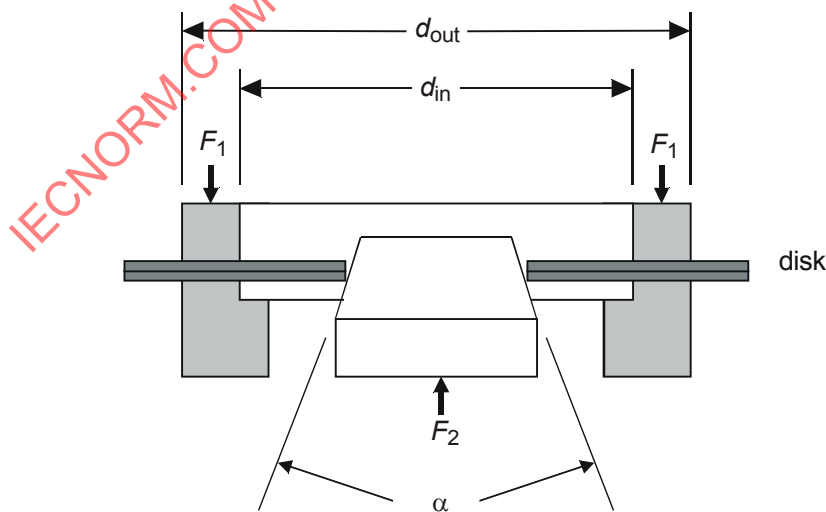

Figure 3 — Clamping and chucking conditions

Clamping shall occur between

$$d_{\text{in}} = 22,3 \text{ mm} \begin{matrix} +0,5 \text{ mm} \\ -0,0 \text{ mm} \end{matrix} \quad \text{and} \quad d_{\text{out}} = 32,7 \text{ mm} \begin{matrix} +0,0 \text{ mm} \\ -0,5 \text{ mm} \end{matrix}$$

The total clamping force shall be $F_1 = 2,0 \pm 0,5 \text{ N}$. In order to prevent warping of the disk under the moment of force generated by the clamping force and the chucking force F_2 exerted on the rim of the centre hole of the disk, F_2 shall not exceed 0,5 N (see Figure 3).

The tapered cone angle, α , shall be $40,0^\circ \pm 0,5^\circ$.

9.5 Rotation of the disk

The actual rotation speed for reading the disk shall be such that it results in the Reference velocity of $3,83 \text{ m/s} \pm 0,03 \text{ m/s}$ at the nominal Channel bit rate of 26,156 25 Mbit/s. The direction of rotation shall be counter-clockwise when viewed from the objective lens.

The actual rotation speed (v_{actual}) for writing the disk shall be such that it includes all velocities for which parameters are specified in the Physical format information in the ADIP Aux Frames in the Lead-in/Lead-out Zone of the disk (see 14.4.1.1 and 14.4.2).

NOTE The rotational speed of the disk is depending on the radial position: $\text{angular velocity} = 60 \times \frac{v_{\text{actual}}}{2\pi \times r} \text{ RPM}$

When testing the disk the actual speed is limited such that the angular velocity does not exceed 10 500 RPM.

9.6 Wobble channel (Read channel 2)

Read channel 2 of the drive provides the wobble signals to control the access to addressed locations on the disk during writing. The wobble signal is generated in Read Channel 2 as a signal ($I_1 - I_2$) related to the difference in the amount of light in the two halves of the exit pupil of the objective lens. The read amplifiers after the photo detectors in the Read channel shall have a flat response within 1 dB from d.c. to 20 MHz.

9.7 Tracking channel (Read channel 2)

Read channel 2 of the drive provides the tracking error signals to control the servos for radial tracking of the optical beam. The radial tracking error is generated in Read Channel 2 as a signal ($I_1 - I_2$) related to the difference in the amount of light in the two halves of the exit pupil of the objective lens.

The method of generating the axial tracking error is not specified for the Reference Drive.

For measuring the disk characteristics, the focusing of the optical beam on the recording layer under test shall be optimized for each recording layer independently. The criterion for the best focus shall be maximum modulated signals (see 31.2.2).

9.8 Reference servo systems

9.8.1 Normalized servo transfer function

The open-loop transfer function, $H_s(i\omega)$ for the axial and radial tracking servos is given by Equation (1),

$$H_s(i\omega) = \frac{1}{3} \times \left(\frac{\omega_0}{i\omega} \right)^2 \times \frac{1 + \frac{3i\omega}{\omega_0}}{1 + \frac{i\omega}{3\omega_0}} \quad (1)$$

where: $i = \sqrt{-1}$, $\omega = 2\pi f$ and $\omega_0 = 2\pi f_0$

and f_0 is the 0 dB crossover frequency of the open-loop transfer function.

The crossover frequencies of the lead-lag network of the servo are

lead break frequency: $f_1 = f_0 / 3$

lag break frequency: $f_2 = f_0 \times 3$

Another frequency of importance is the frequency f_x at which a sinusoidal displacement with an amplitude equal to the maximum allowed residual tracking error e_{\max} , corresponds to the maximum expected acceleration α_{\max} . This frequency can be calculated as follows:

$$f_x = \frac{1}{2\pi} \sqrt{\frac{\alpha_{\max}}{e_{\max}}}$$

Because the tracking error signals from the disk can have rather large variations, the tracking error signal fed into each reference servo loop shall be adjusted to a fixed level (effectively calibrating the total loop gain), such to guarantee the specified bandwidth.

9.8.2 Reference Servo for Axial Tracking

The crossover frequency of the normalized servo transfer function (H_s) for axial tracking, $f_0 = \omega_0 / (2\pi)$ shall be given by Equation (2), where α_{\max} is the maximum expected axial acceleration of 8,0 m/s², which is multiplied by a factor $m = 1,5$ for servo margin. The tracking error e_{\max} , caused by this $m \times \alpha_{\max}$, shall be 0,20 μm .

Thus the crossover frequency f_0 shall be given by

$$f_0 = \frac{1}{2\pi} \sqrt{\frac{3 \times m \times \alpha_{\max}}{e_{\max}}} = \frac{1}{2\pi} \sqrt{\frac{3 \times 1,5 \times 8}{0,20 \times 10^{-6}}} = 2,1 \text{ kHz} \quad (2)$$

For an open loop transfer function H of the Reference Servo for axial tracking, $|1+H|$ is limited as schematically shown by the shaded region of Figure 4.

Bandwidth from 100 Hz to 10 kHz

$|1+H|$ shall be within 20 % of $|1+H_s|$.

Bandwidth from 26 Hz to 100 Hz

$|1+H|$ shall be within the limits enclosed by the following four points.

- 1) 41,7 dB at 100 Hz ($|1+H_s|$ at 100 Hz – 20 %)
- 2) 45,2 dB at 100 Hz ($|1+H_s|$ at 100 Hz + 20 %)
- 3) 65,1 dB at 26 Hz ($|1+H_s|$ at 26 Hz – 20 %)
- 4) 85,1 dB at 26 Hz ($|1+H_s|$ at 26 Hz – 20 % + 20 dB)

Bandwidth from 9,5 Hz to 26 Hz

$|1+H|$ shall be between 65,1 dB and 85,1 dB.

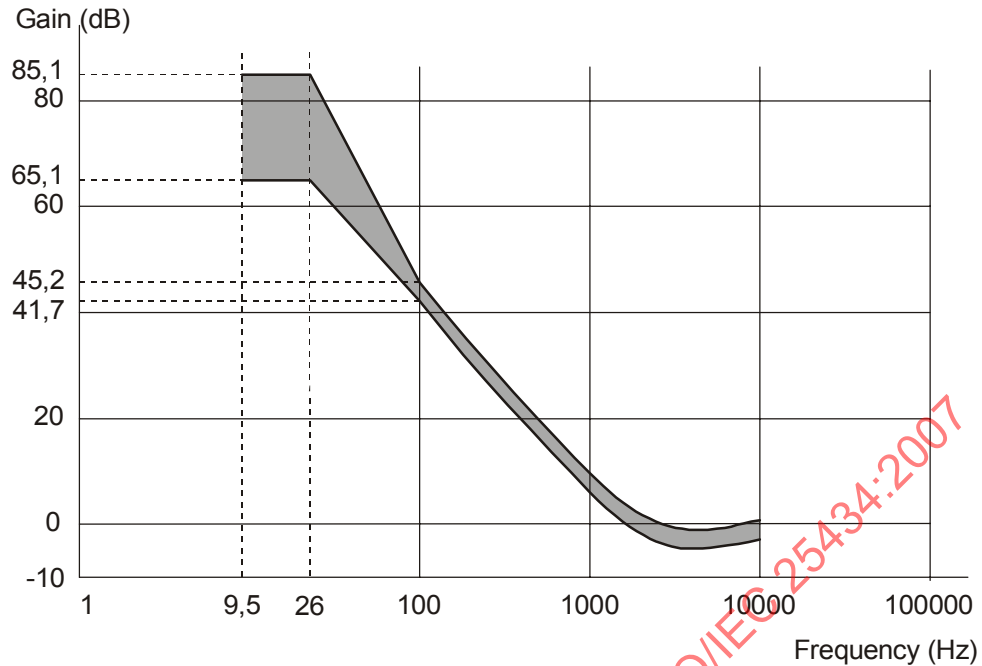

Figure 4 — Reference servo for axial tracking

9.8.3 Reference Servo for Radial Tracking

The crossover frequency of the normalized servo transfer function (H_s) for radial tracking, $f_0 = \omega_0 / (2\pi)$ shall be given by Equation (3), where α_{\max} is the maximum expected radial acceleration of $1,1 \text{ m/s}^2$, which is multiplied by a factor $m = 1,5$ for servo margin. The tracking error e_{\max} , caused by this $m \times \alpha_{\max}$, shall be $0,022 \text{ } \mu\text{m}$.

Thus the crossover frequency f_0 shall be given by

$$f_0 = \frac{1}{2\pi} \sqrt{\frac{3 \times m \times \alpha_{\max}}{e_{\max}}} = \frac{1}{2\pi} \sqrt{\frac{3 \times 1,5 \times 1,1}{0,022 \times 10^{-6}}} = 2,4 \text{ kHz} \quad (3)$$

For an open loop transfer function H of the Reference Servo for radial tracking, $|1+H|$ is limited as schematically shown by the shaded region of Figure 5.

Bandwidth from 100 Hz to 10 kHz

$|1+H|$ shall be within 20 % of $|1+H_s|$.

Bandwidth from 28,2 Hz to 100 Hz

$|1+H|$ shall be within the limits enclosed by the following four points.

- 1) 43,7 dB at 100 Hz ($|1+H_s|$ at 100 Hz – 20 %)
- 2) 47,2 dB at 100 Hz ($|1+H_s|$ at 100 Hz + 20 %)
- 3) 65,6 dB at 28,2 Hz ($|1+H_s|$ at 28,2 Hz – 20 %)
- 4) 85,6 dB at 28,2 Hz ($|1+H_s|$ at 28,2 Hz – 20 % + 20 dB)

Bandwidth from 9,5 Hz to 28,2 Hz

$|1+H|$ shall be between 65,6 dB and 85,6 dB.

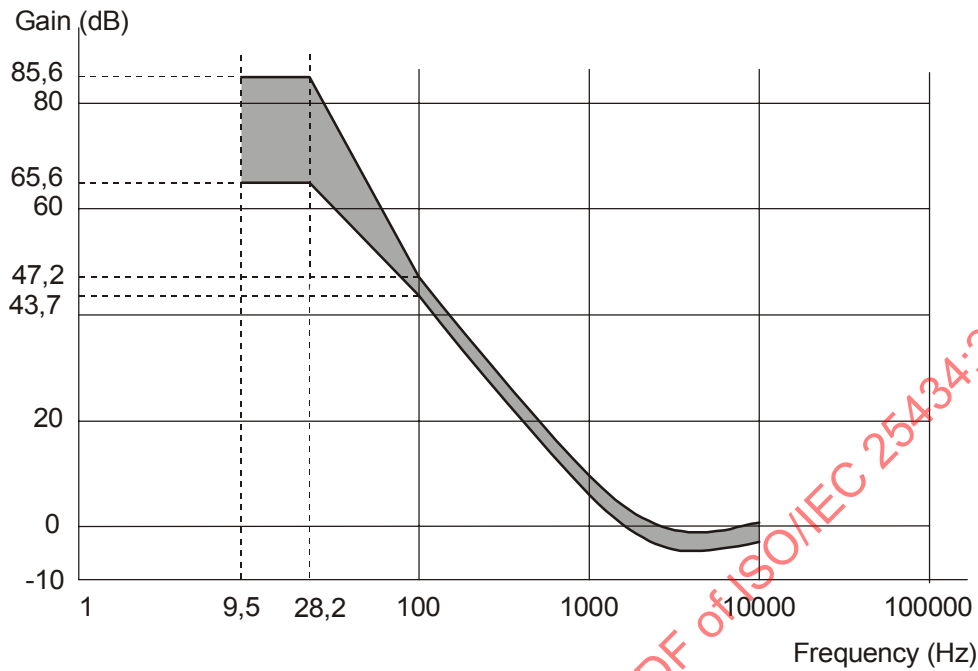

Figure 5 — Reference servo for radial tracking

Section 2 - Dimensional, mechanical and physical characteristics of the disk

10 Dimensional characteristics

Dimensional characteristics are specified for those parameters deemed mandatory for interchange and compatible use of the disk. Where there is freedom of design, only the functional characteristics of the elements described are indicated. The enclosed drawing, Figure 6 shows the dimensional requirements in summarized form. The different parts of the disk are described from the centre hole to the outside rim.

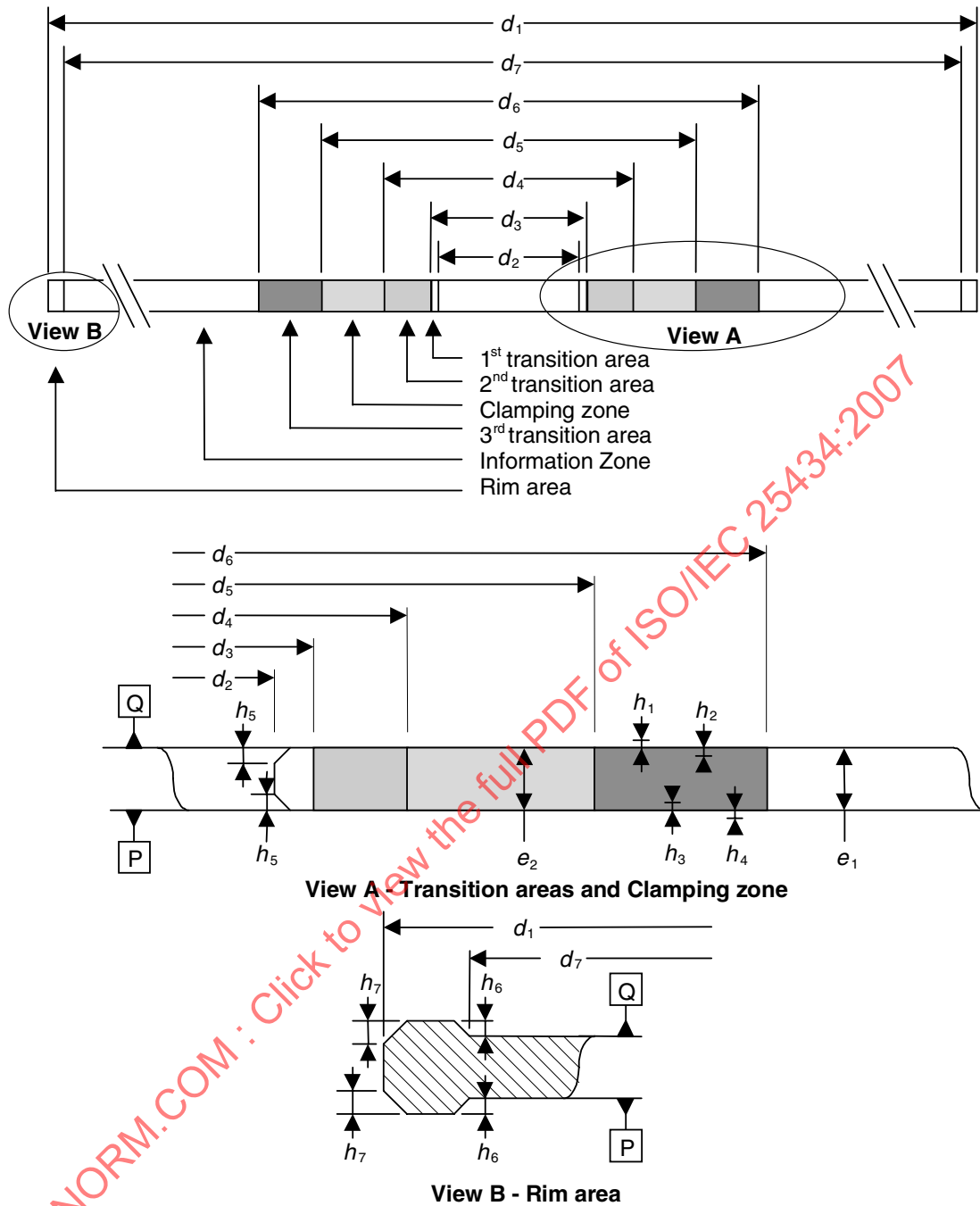

Figure 6 — Physical disk dimensions

10.1 Reference Planes

The dimensions are referred to two Reference Planes P and Q.

Reference Plane P is the primary Reference Plane. It is the plane on which the bottom surface of the Clamping Zone rests (see 10.5).

Reference Plane Q is the plane parallel to Reference Plane P at the height of the top surface of the Clamping Zone.

10.2 Overall dimensions

The disk shall have an overall diameter (see also Annex A)

$$d_1 = 120,00 \text{ mm} \pm 0,30 \text{ mm}$$

The centre hole of a substrate or a dummy substrate shall have a diameter (see Figure 7)

$$d_{\text{substrate}} = 15,00 \text{ mm} \begin{matrix} +0,15 \text{ mm} \\ -0,00 \text{ mm} \end{matrix}$$

The hole of an assembled disk, i.e. with both parts bonded together, shall have a diameter

$$d_2 = 15,00 \text{ mm min.}$$

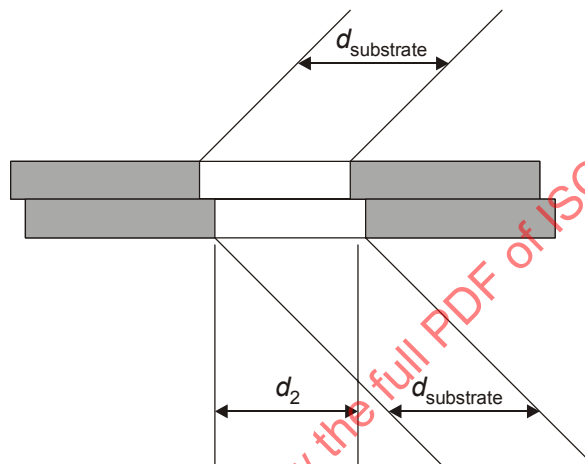

Figure 7 — Hole diameters for an assembled disk

The corners of the centre hole shall be free of any burrs or sharp features and shall be rounded off or chamfered by

$$h_5 = 0,1 \text{ mm max.}$$

The thickness of the disk shall be

$$e_1 = 1,20 \text{ mm} \begin{matrix} +0,30 \text{ mm} \\ -0,06 \text{ mm} \end{matrix}$$

10.3 First transition area

In the area defined by d_2 and

$$d_3 = 16,0 \text{ mm min.}$$

the surface of the disk is permitted to be above Reference Plane P and/or below Reference Plane Q by 0,10 mm max.

10.4 Second transition area

This area shall extend between diameter d_3 and diameter

$$d_4 = 22,0 \text{ mm max.}$$

In this area the disk may have an uneven surface or burrs up to 0,05 mm max. beyond Reference Planes P and/or Q.

10.5 Clamping Zone

This Zone shall extend between diameter d_4 and diameter

$$d_5 = 33,0 \text{ mm min.}$$

Each side of the Clamping Zone shall be flat within 0,1 mm. The top side of the Clamping Zone, i.e. that of Reference Plane Q shall be parallel to the bottom side, i.e. that of Reference Plane P within 0,1 mm.

In the Clamping Zone the thickness e_2 of the disk shall be

$$e_2 = 1,20 \text{ mm} \begin{matrix} +0,20 \text{ mm} \\ -0,10 \text{ mm} \end{matrix}$$

10.6 Third transition area

This area shall extend between diameter d_5 and diameter

$$d_6 = 44,0 \text{ mm max.}$$

In this area the top surface is permitted to be above Reference Plane Q by

$$h_1 = 0,25 \text{ mm max.}$$

or below Reference Plane Q by

$$h_2 = 0,10 \text{ mm max.}$$

The bottom surface is permitted to be above Reference Plane P by

$$h_3 = 0,10 \text{ mm max.}$$

or below Reference Plane P by

$$h_4 = 0,25 \text{ mm max.}$$

10.7 Information Zone

The Information Zone shall extend over both recording layers between diameter d_6 and diameter

$$d_7 = 117,5 \text{ mm min (see also Annex A).}$$

10.7.1 Sub-division of the Information Zone

The main parts of the Information Zone are (see Figure 8):

- two Inner Drive Areas
- one **Lead-in Zone** and one **Lead-out Zone**
- one **Data Zone** (the two parts of the Data Zone, extending over the two layers, are shown as the maximum available zones for the storage of user data and shall be treated as one contiguous Data Zone)
- two **Middle Zones**
- two Outer Drive Areas.

The beginning of the Data Zone on Layer 0 and the default end of the Data Zone on Layer 1 shall be located at diameter

$$d_8 = 48,00 \text{ mm} \begin{matrix} +0,00 \text{ mm} \\ -0,40 \text{ mm} \end{matrix}$$

which is the end of the Lead-in Zone on Layer 0 and the default beginning of the Lead-out Zone on Layer 1.

The Lead-out Zone shall start immediately after the Data Zone on Layer 1 and end at about the same location as the start of the Lead-in Zone (see also 16.1).

The end of the Data Zone on Layer 0 and the beginning of the Data Zone on Layer 1 shall be located at diameter

$$d_9 = 116,00 \text{ mm max,}$$

which is the beginning/end of the Middle Zones (see also Annex A).

The radial misalignment ($|\Delta R|$) between the outer edges of the Data Zones on Layer 0 and Layer 1 shall be 0,20 mm max.

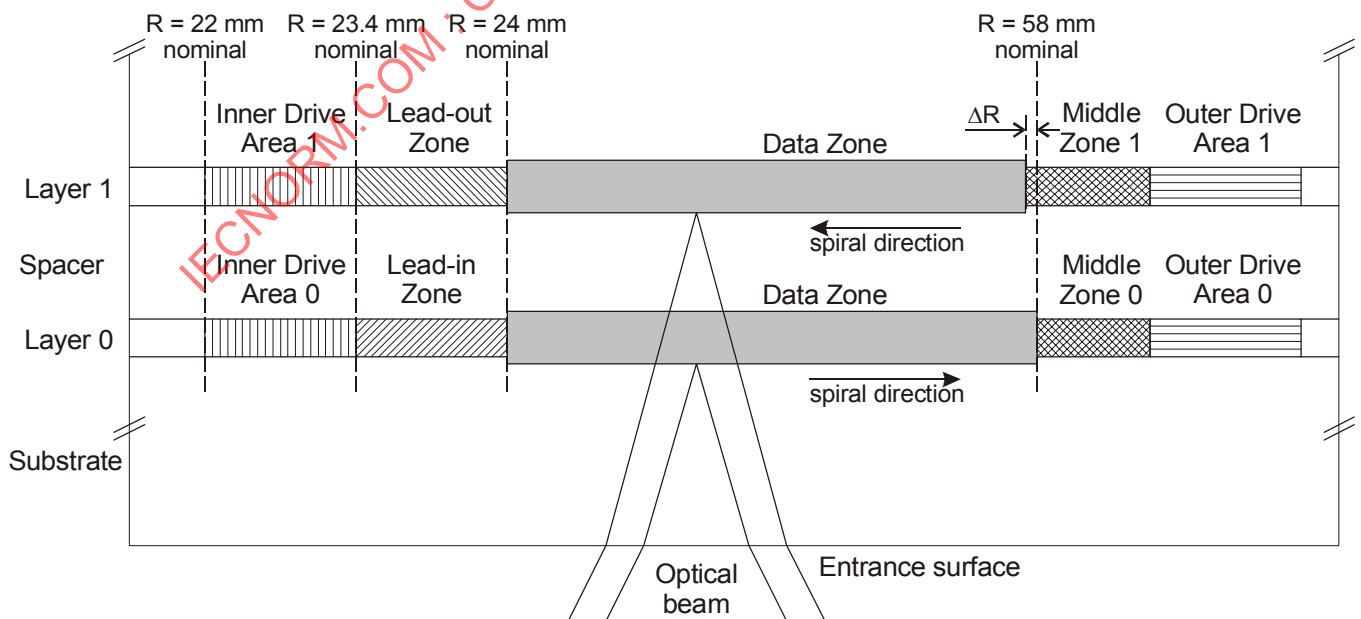

Figure 8 — Layout of the Information Zone

10.7.2 Track mode

+R DL disks shall only use the so-called Opposite Track Path (OTP) mode. In this mode, tracks are read starting on Layer 0 at the inner diameter of the Information Zone, continuing on Layer 1 from the outer diameter towards the inner diameter. Thus, there is a Middle Zone at the outer diameter on both layers (see Figure 8).

The spiral track is running from the inside to the outside on Layer 0 and in the reverse direction on Layer 1.

10.8 Rim area

The rim area is that area extending from diameter d_7 to diameter d_1 . In this area the surfaces are permitted to both extend beyond Reference Plane Q or Reference Plane P

$$h_6 = 0,1 \text{ mm max.}$$

The outer corners of the disk shall be free of any burrs or sharp features and shall be rounded off or chamfered by

$$h_7 = 0,2 \text{ mm max.}$$

10.9 Remark on tolerances

All heights specified in the preceding clauses and indicated by h_i are independent from each other. This means that, for example, if the top surface of the third transition area is below Reference Plane Q by up to h_2 , there is no implication that the bottom surface of this area has to be above Reference Plane P by up to h_3 . Where dimensions have the same - generally maximum - numerical value, this does not imply that the actual values have to be identical.

11 Mechanical characteristics

11.1 Mass

The mass of the disk shall be in the range of 13,0 g to 20,0 g (see also Annex A).

11.2 Moment of inertia

The moment of inertia of the disk, relative to its rotation axis, shall not exceed 0,040 g·m² (see also Annex A).

11.3 Dynamic imbalance

The dynamic imbalance of the disk, relative to its rotation axis, shall not exceed 2,5 g·mm (see also Annex A).

11.4 Axial runout

When measured by the optical system with the Reference Servo for axial tracking, the disk rotating at the Reference velocity of 3,83 m/s (see 9.5), the deviation of each recording layer from its nominal position in the direction normal to the Reference Planes shall not exceed 0,30 mm.

Some explanation about the use of the Reference Servo as a measurement tool and the way to translate the measurement results to a practical implementation for a high-speed servo is given in Annex L.

11.4.1 Tracking requirements at the Reference velocity (CLV)

The residual tracking error below 10 kHz, measured on the blank disk using the Reference Servo for axial tracking and the disk rotating at the Reference velocity, shall not exceed 0,13 μm (displacement of the objective lens needed to move the focal point of the optical beam onto the recording layer).

The measuring filter shall be a Butterworth LPF,

f_c (-3 dB): 10 kHz, with slope: -80 dB/decade.

11.4.2 Tracking requirements at 3 000 RPM (CAV)

Discs suited to be recorded at speeds $> 2,4\times$ the Reference Velocity, shall also fulfil the following requirement:

the residual tracking error below 10 kHz, measured on the blank disc using the Reference Servo for axial tracking and the disc rotating at a fixed rotational speed of 3 000 RPM, shall not exceed $E_{ax}(r)$ μm , where E_{ax} is a function of the radius r according to the following specifications:

for $r \leq 29$ mm: $E_{ax}(r) = 0,20$ μm and

for $r \geq 29$ mm: $E_{ax}(r) = \left(\frac{r}{29}\right)^2 \times 0,20$ μm with r expressed in mm.

If present, the 50 Hz component shall be removed from the residual tracking error before applying these requirements (e.g. by software processing of the sampled measurement data).

11.5 Radial runout

The runout of the outer edge of the disk shall not exceed 0,30 mm peak-to-peak.

The radial runout of tracks shall not exceed 70 μm peak-to-peak on each recording layer.

Some explanation about the use of the Reference Servo as a measurement tool and the way to translate the measurement results to a practical implementation for a high-speed servo is given in Annex L.

11.5.1 Tracking requirements at the Reference velocity (CLV)

The residual tracking error below 1,1 kHz ($= f_x$ as defined in 9.8.1), measured on the blank disk using the Reference Servo for radial tracking and the disk rotating at the Reference velocity of 3,83 m/s (see 9.5), shall not exceed 0,015 μm .

The measuring filter shall be a Butterworth LPF,

f_c (-3 dB): 1,1 kHz, with slope: -80 dB/decade.

The rms noise value of the residual error signal in the frequency band from 1,1 kHz to 10 kHz, measured with an integration time of 20 ms, using the Reference Servo for radial tracking, shall not exceed 0,016 μm .

The measuring filter shall be a Butterworth BPF,

frequency range (-3 dB) : 1,1 kHz, with slope: +80 dB/decade

to : 10 kHz, with slope: -80 dB/decade.

11.5.2 Tracking requirements at 3 000 RPM (CAV)

Discs suited to be recorded at speeds $> 2,4\times$ the Reference Velocity, shall also fulfil the following requirement:

the residual tracking error below 10 kHz, measured on the blank disc using the Reference Servo for radial tracking and the disc rotating at a fixed rotational speed of 3 000 RPM, shall not exceed $E_{\text{rad}}(r)$ μm , where E_{rad} is a function of the radius r according to the following specifications:

for $r \leq 29$ mm: $E_{\text{rad}}(r) = 0,025$ μm and

for $r \geq 29$ mm: $E_{\text{rad}}(r) = \left(\frac{r}{29}\right)^2 \times 0,025$ μm with r expressed in mm.

If present, the 50 Hz component shall be removed from the residual tracking error before applying these requirements (e.g. by software processing of the sampled measurement data). This process effectively removes the influence of the pure eccentricity of the disc.

12 Optical characteristics in the Information Zone

12.1 Index of refraction

The index of refraction IR of the substrate in the Information Zone shall be $1,55 \pm 0,10$.

The index of refraction of the spacer shall be $(IR \pm 0,10)$.

12.2 Thickness of the substrate

The thickness of the substrate or the thickness of the substrate + the spacer, from the entrance surface to the recording layer concerned, varies with the index of refraction of the substrate/spacer and shall be defined as the enclosed region in Figure 9.

The thickness of the spacer shall be $55 \mu\text{m} \begin{matrix} +15 \mu\text{m} \\ -10 \mu\text{m} \end{matrix}$. Within each side of a disk, this thickness shall not vary more than 10 μm pp.

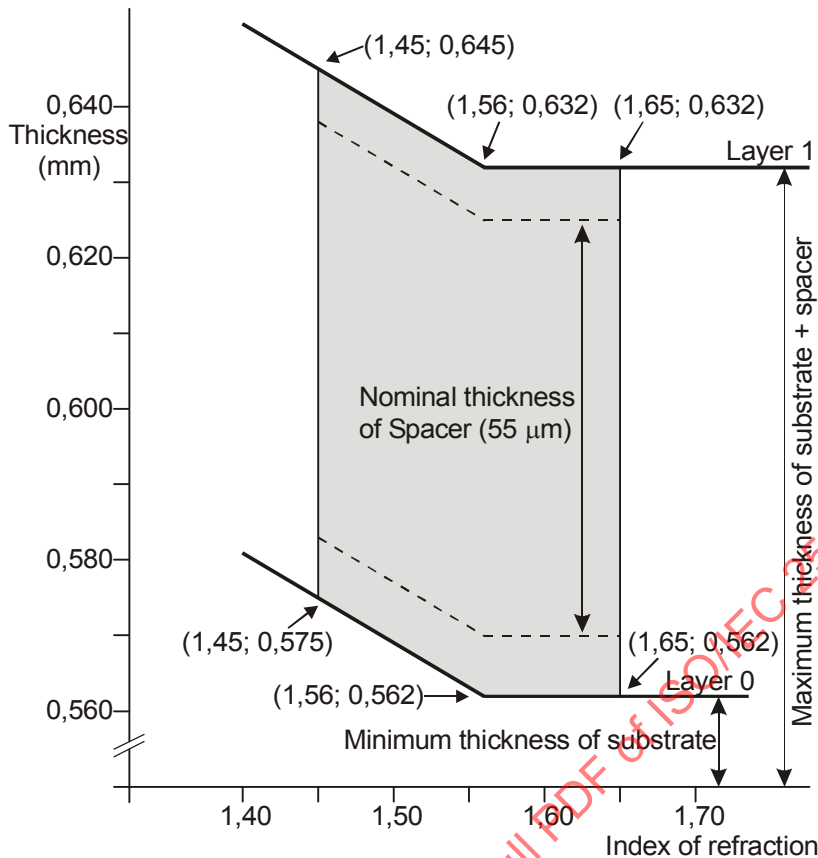

Figure 9 — Thickness of the substrate

12.3 Reflectivity

The double-pass optical transmission of the involved layers and the reflectivity of the recording layer concerned are measured together as the reflectance R of that recording layer. When measured according to Annex C the value of R shall be in the Information Zone

$0,16 \leq R_d \leq 0,30$ in the unrecorded groove on Layer 0 and Layer 1
(in an area where both layers are unrecorded)

$0,16 \leq R_{14H} \leq 0,30$ in the recorded groove on Layer 0 and Layer 1
(in an area where both layers are recorded)

12.4 Birefringence

The birefringence of the substrate and of the substrate + spacer shall not exceed 60 nm when measured according to Annex D.

12.5 Angular deviation

The angular deviation is the angle α between a parallel incident beam perpendicular to the Reference Plane P and the reflected beam (see Figure 10). The incident beam shall have a diameter in the range 0,30 mm to 3,0 mm. This angle α includes deflection due to the entrance surface and to the unparallelism of the recording layer with the entrance surface.

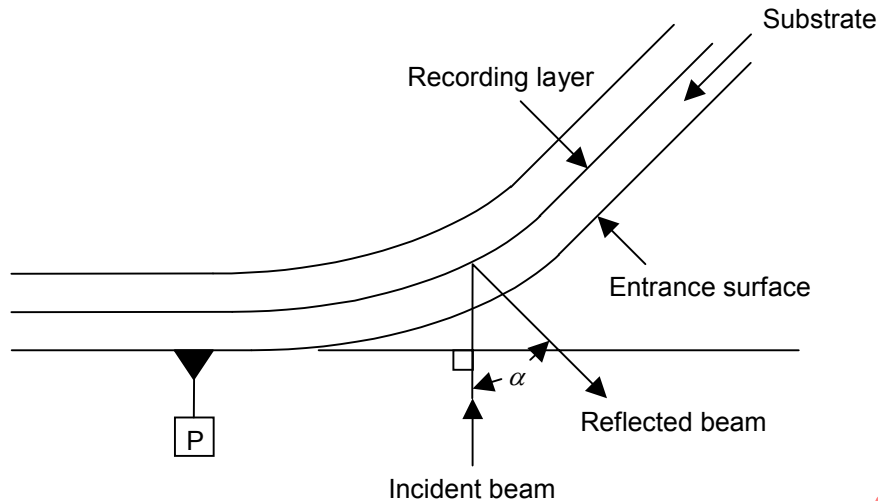

Figure 10 — Angular deviation □

The angular deviation shall be

In radial direction: $|\alpha| = 0,70^\circ$ max.

The variation of α in radial direction over one revolution shall be $0,80^\circ$ peak-to-peak max.

In tangential direction: $|\alpha| = 0,30^\circ$ max.

Section 3 - Format of information

13 Data format

The data received from the host, called Main Data, is formatted in a number of steps before being recorded on the disk.

It is transformed successively into

- a Data Frame,
- a Scrambled Frame,
- an ECC Block,
- 16 Recording Frames,
- 16 Physical Sectors,
- a Recording Unit.

These steps are specified in the following clauses.

13.1 Data Frames

A Data Frame shall consist of 2 064 bytes arranged in an array of 12 rows each containing 172 bytes (Figure 11). The first row shall start with three fields, called Identification Data (ID), ID Error Detection Code (IED), and RSV bytes, followed by 160 Main Data bytes. The next 10 rows shall each contain 172 Main Data bytes, and the last row shall contain 168 Main Data bytes followed by four bytes for recording an Error Detection Code (EDC). The 2 048 Main Data bytes are identified as D_0 to $D_{2\,047}$.

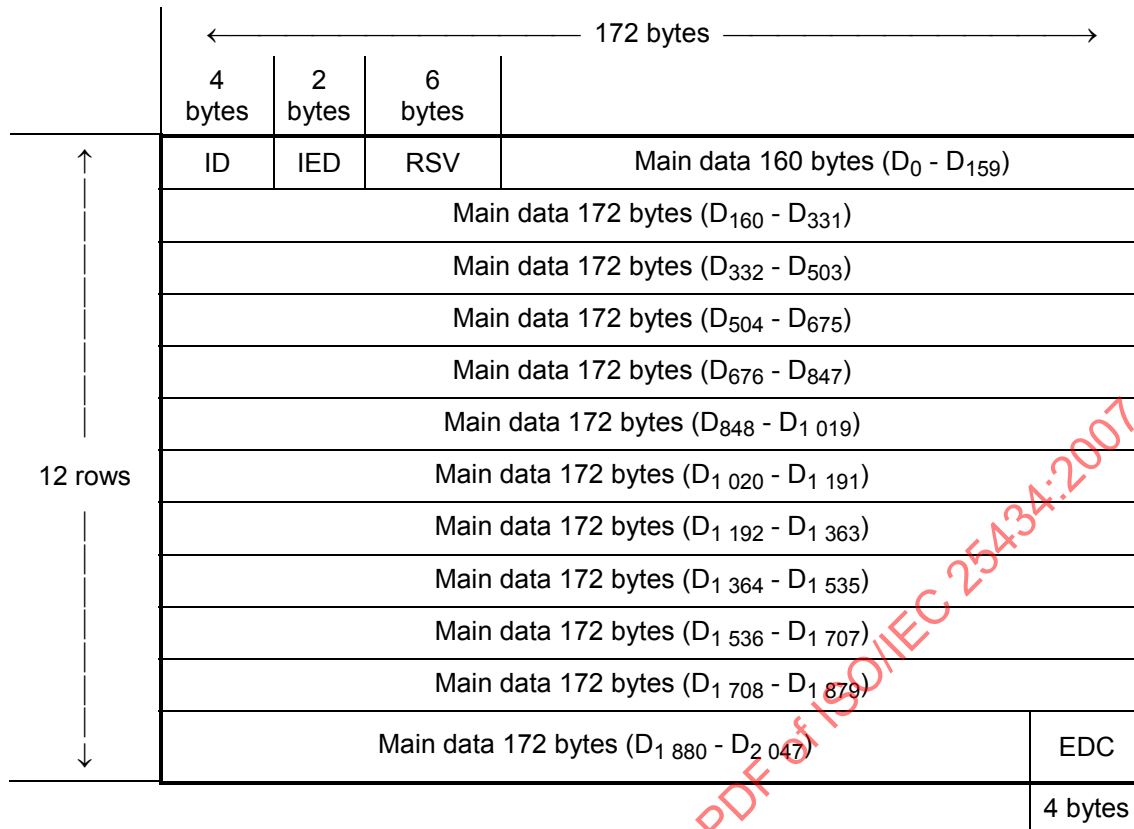

Figure 11 — Data Frame

13.1.1 Identification Data (ID)

This field shall consist of four bytes, the bits of which are numbered consecutively from b₀ (lsb) to b₃₁ (msb), see Figure 12.

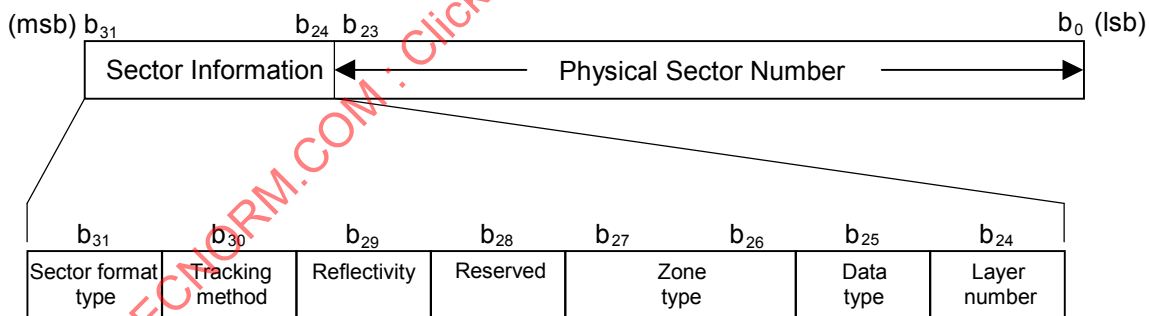

Figure 12 — Identification Data (ID)

The bits of the most significant byte, the Sector Information, shall be set as follows:

- Bit b₃₁ shall be set to ZERO, indicating a CLD format
- Bit b₃₀ shall be set to ZERO, indicating pit tracking capability (see 32.2.5)
- Bit b₂₉ shall be set to ONE indicating that the reflectance is less than 40 %
- Bit b₂₈ shall be set to ZERO

Bits b_{27} to b_{26}	shall be set to	ZERO ZERO in the Data Zone ZERO ONE in the Lead-in Zone ONE ZERO in the Lead-out Zone ONE ONE in the Middle Zone
Bit b_{25}	shall be set to	ZERO, indicating read only data.
Bit b_{24}	shall be set to	ZERO on Layer 0 ONE on Layer 1

The least significant three bytes, bits b_{23} to b_0 , shall specify the Physical Sector Number in binary notation. The Physical Sector Number of the first Physical Sector of an ECC Block shall be an integer multiple of 16.

13.1.2 ID Error Detection Code (IED)

When identifying all bytes of the array shown in Figure 11 as $C_{i,j}$ for $i = 0$ to 11 and $j = 0$ to 171, the bytes of IED are represented by $C_{0,j}$ for $j = 4$ to 5. Their setting is obtained as follows.

$$\text{IED}(x) = \sum_{j=4}^5 C_{0,j} x^{5-j} = l(x) x^2 \text{ mod } G_E(x)$$

where

$$l(x) = \sum_{j=0}^3 C_{0,j} x^{3-j} \text{ and } G_E(x) = (x + 1)(x + \alpha)$$

α is the primitive root of the primitive polynomial $P(x) = x^8 + x^4 + x^3 + x^2 + 1$

13.1.3 RSV

This field shall consist of 6 bytes. The first byte may be set by the application. If not specified by the application, it is reserved and shall be set to (00). The remaining 5 bytes are reserved and shall all be set to (00). Under no circumstance may other data received from the host be recorded in this field.

Circumvention: *Recorders and recording drives shall be considered as circumvention devices when these are produced to record, or can easily be modified to record, in any manner, a user-defined number in this field.*

13.1.4 Error Detection Code (EDC)

This 4-byte field shall contain the parities of an Error Detection Code computed over the preceding 2 060 bytes of the Data Frame. Considering the Data Frame as a single bit field starting with the most significant bit of the first byte of the ID field and ending with the least significant bit of the EDC field, then this msb will be $b_{16\ 511}$ and the lsb will be b_0 . Each bit b_i of the EDC is shown as follows for $i = 0$ to 31:

$$\text{EDC}(x) = \sum_{i=0}^{31} b_i x^i = l(x) \text{ mod } G(x)$$

where

$$l(x) = \sum_{i=32}^{16\ 511} b_i x^i \text{ and } G(x) = x^{32} + x^{31} + x^4 + 1$$

13.2 Scrambled Frames

The 2 048 Main Data bytes shall be scrambled by means of the circuit shown in Figure 13 which shall consist of a feedback bit shift register in which bits r_7 (msb) to r_0 (lsb) represent a scrambling byte at each 8-bit shift.

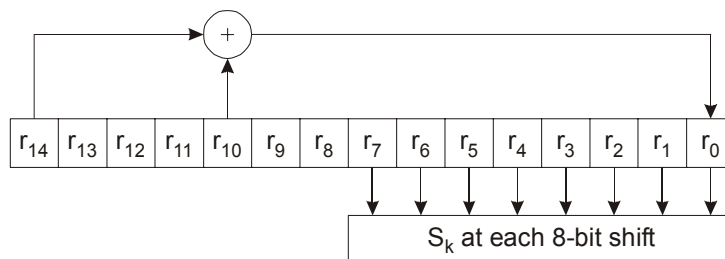

Figure 13 — Feedback shift register

At the beginning of the scrambling procedure of a Data Frame, positions r_{14} to r_0 shall be pre-set to the value(s) specified in Table 1 (the msb of the pre-set value shall be discarded). The same pre-set value shall be used for 16 consecutive Data Frames. After 16 groups of 16 Data Frames, the sequence is repeated. The initial pre-set number is equal to the value represented by bits b_7 (msb) to b_4 (lsb) of the ID field of the Data Frame. Table 1 specifies the initial pre-set value of the shift register corresponding to the 16 initial pre-set numbers.

Table 1 — Initial values of the shift register

Initial pre-set number	Initial pre-set value	Initial pre-set number	Initial pre-set value
(0)	(0001)	(8)	(0010)
(1)	(5500)	(9)	(5000)
(2)	(0002)	(A)	(0020)
(3)	(2A00)	(B)	(2001)
(4)	(0004)	(C)	(0040)
(5)	(5400)	(D)	(4002)
(6)	(0008)	(E)	(0080)
(7)	(2800)	(F)	(0005)

The part of the initial value of r_7 to r_0 is taken out as scrambling byte S_0 . After that, an 8-bit shift is repeated 2 047 times and the following 2 047 bytes shall be taken from r_7 to r_0 as scrambling bytes S_1 to $S_{2\,047}$. The Main Data bytes D_k of the Data Frame become scrambled bytes D'_k where

$$D'_k = D_k \oplus S_k \text{ for } k = 0 \text{ to } 2\,047 \text{ (}\oplus\text{ stands for Exclusive OR)}$$

13.3 ECC Blocks

An ECC Block is formed by arranging 16 consecutive Scrambled Frames in an array of 192 rows of 172 bytes each (Figure 14). To each of the 172 columns 16 bytes of Parity of Outer Code are added, then, to each of the resulting 208 rows, 10 bytes of Parity of Inner Code are added. Thus a complete ECC Block comprises 208 rows of 182 bytes each. The bytes of this array are identified as $B_{i,j}$ as follows, where i is the row number and j is the column number.

$B_{i,j}$ for $i = 0$ to 191 and $j = 0$ to 171 are bytes from the Scrambled Frames

$B_{i,j}$ for $i = 192$ to 207 and $j = 0$ to 171 are bytes of the Parity of Outer Code

$B_{i,j}$ for $i = 0$ to 207 and $j = 172$ to 181 are bytes of the Parity of Inner Code

13.4 Recording Frames

Sixteen Recording Frames shall be obtained by interleaving one of the 16 PO rows at a time after every 12 rows of an ECC Block (Figure 15). This is achieved by re-locating the bytes $B_{i,j}$ of the ECC Block as $B_{m,n}$ for

$$m = i + \text{int} [i / 12] \text{ and } n = j \text{ for } i \leq 191$$

$$m = 13 \times (i - 191) - 1 \text{ and } n = j \text{ for } i \geq 192$$

where $\text{int} [x]$ represents the largest integer not greater than x .

Thus the 37 856 bytes of an ECC Block are re-arranged into 16 Recording Frames of 2 366 bytes. Each Recording Frame consists of an array of 13 rows of 182 bytes.

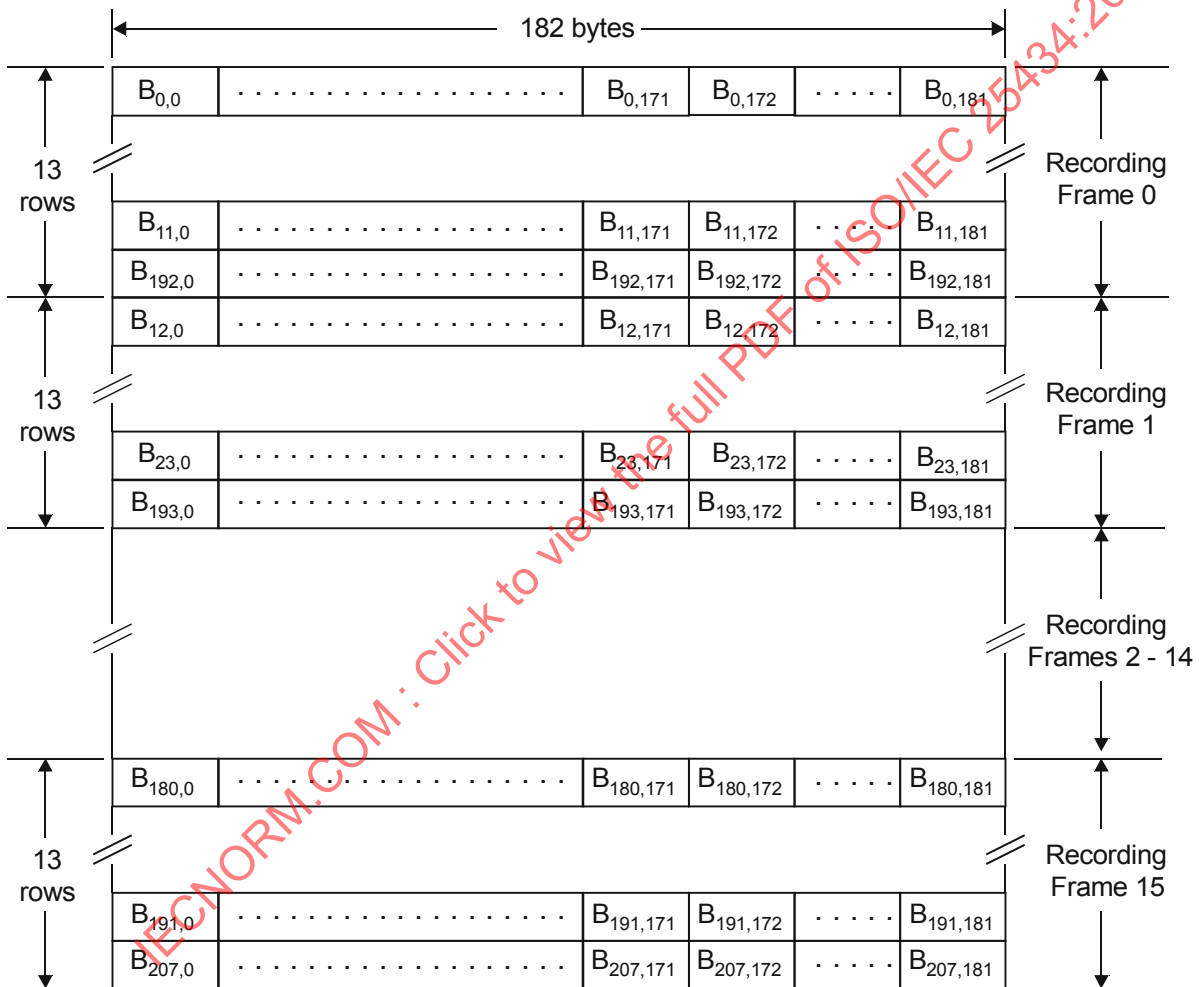

Figure 15 — Recording Frames obtained from an ECC Block

13.5 Modulation and NRZI conversion

The 8-bit bytes of each Recording Frame shall be transformed into 16-bit Code Words with the run length limitation that between 2 ONEs there shall be at least 2 ZEROs and at most 10 ZEROs (RLL(2,10)). Annex H specifies the conversion tables to be applied. The Main Conversion table and the Substitution table specify a 16-bit Code Word for each 256 8-bit bytes with one of 4 States. For each 8-bit byte, the tables indicate the corresponding Code Word, as well as the State for the next 8-bit byte to be encoded.

The 16-bit Code Words shall be NRZI-converted into Channel bits before recording on the disk (see Figure 16). The Channel clock period is the time between 2 consecutive Channel bits.

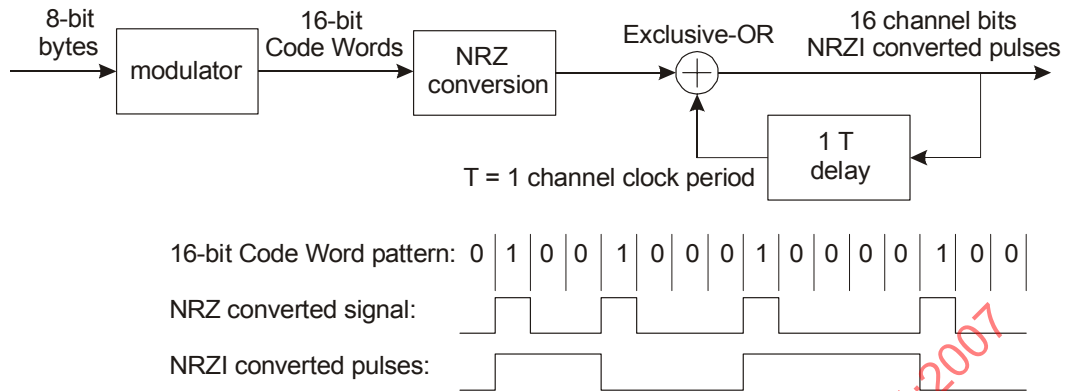

Figure 16 — NRZI conversion

13.6 Physical Sectors

The structure of a Physical Sector is shown in Figure 17. It shall consist of 13 rows, each comprising two Sync Frames. A Sync Frame shall consist of a SYNC Code from Table 2 and 1 456 Channel bits representing 91 8-bit bytes. Each row of the Physical Sector shall consist of two Sync Frames with the first 1 456 Channel bits representing the first 91 bytes of each row of a Recording Frame and the second 1 456 Channel bits representing the second 91 bytes of each row of a Recording Frame.

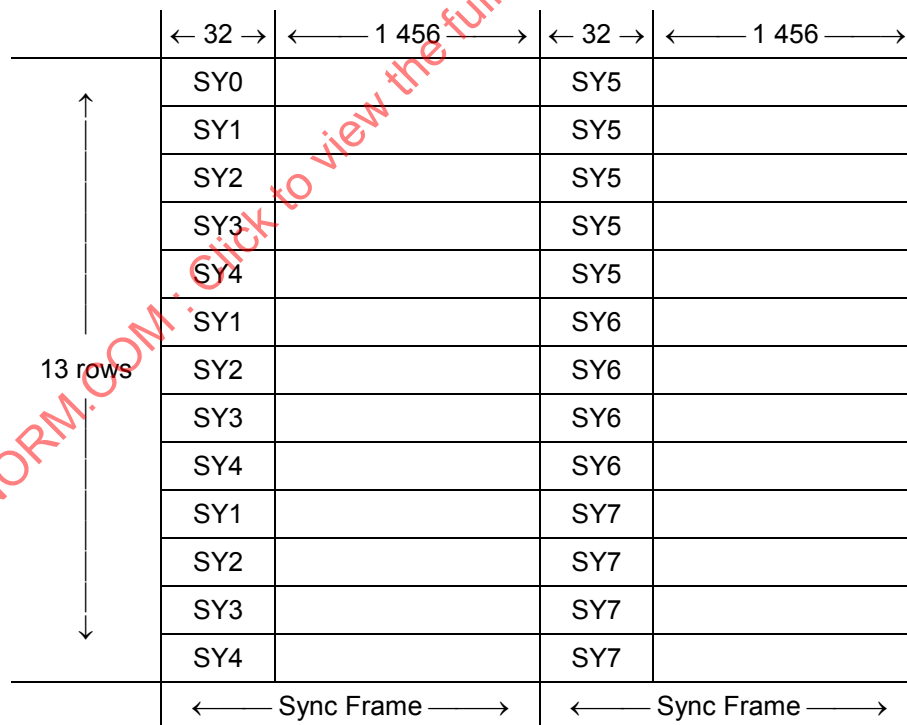

Figure 17 — Physical Sector

Recording of the Physical Sector shall start with the first Sync Frame of the first row, followed by the second Sync Frame of that row, and so on, row-by-row. The state of each SYNC Code and each subsequent set of 16 Channel bits shall follow the rules defined in 13.8.

Table 2 — SYNC Codes

State 1 and State 2 (next state is state 1)			
Primary SYNC codes		Secondary SYNC codes	
(msb)	(lsb)	(msb)	(lsb)
SY0 = 0001001001000100	000000000010001	/ 000100100000100	000000000010001
SY1 = 0000010000000100	000000000010001	/ 0000010001000100	000000000010001
SY2 = 0001000000000100	000000000010001	/ 0001000001000100	000000000010001
SY3 = 0000100000000100	000000000010001	/ 0000100001000100	000000000010001
SY4 = 0010000000000100	000000000010001	/ 0010000001000100	000000000010001
SY5 = 0010001001000100	000000000010001	/ 0010001000000100	000000000010001
SY6 = 0010010010000100	000000000010001	/ 0010000100000100	000000000010001
SY7 = 0010010001000100	000000000010001	/ 0010010000000100	000000000010001
State 3 and State 4 (next state is state 1)			
Primary SYNC codes		Secondary SYNC codes	
(msb)	(lsb)	(msb)	(lsb)
SY0 = 1001001000000100	000000000010001	/ 1001001001000100	000000000010001
SY1 = 1000010001000100	000000000010001	/ 1000010000000100	000000000010001
SY2 = 1001000001000100	000000000010001	/ 1001000000000100	000000000010001
SY3 = 1000001001000100	000000000010001	/ 1000001000000100	000000000010001
SY4 = 1000100001000100	000000000010001	/ 1000100000000100	000000000010001
SY5 = 1000100100000100	000000000010001	/ 1000000100000100	000000000010001
SY6 = 100100000100000100	000000000010001	/ 1000000001000100	000000000010001
SY7 = 1000100010000100	000000000010001	/ 1000000010000100	000000000010001

13.7 Layout of a Recording Unit (RUN)

A RUN shall consist of an integer number ($M \geq 1$) of sets of 16 Physical Sectors, each from a single ECC Block. The M ECC Blocks shall be preceded by 8 Channel bits, which are meant to reduce possible influences of inaccuracies of the linking point, while the last 8 Channel bits of the last Physical Sector shall be discarded at recording. The 8 linking Channel bits and the next SYNC Code SY0 (chosen from State 1/2 or State 3/4) shall be chosen randomly, such that the runlength constraints specified in 13.5 are fulfilled.

Each RUN of M ECC Blocks ($M \geq 1$) starting with ECC Block N shall be recorded in the following way:

- 8 Channel bits for linking in ECC Block $N-1$,
- full ECC Blocks N to $N + M - 2$ (if $M \geq 2$),
- ECC Block $N + M - 1$, except for the last 8 Channel bits, which bits shall not be recorded.

The positioning of a Recording Unit is shown in Figure 18.

When the RUN starting with ECC Block N is to be recorded, and ECC Block $N-1$ has not yet been recorded, then the RUN shall be extended with a dummy ECC Block $N-1$ of which all Main Data bytes shall be set to (00) (see also clause 24: Sequential recording).

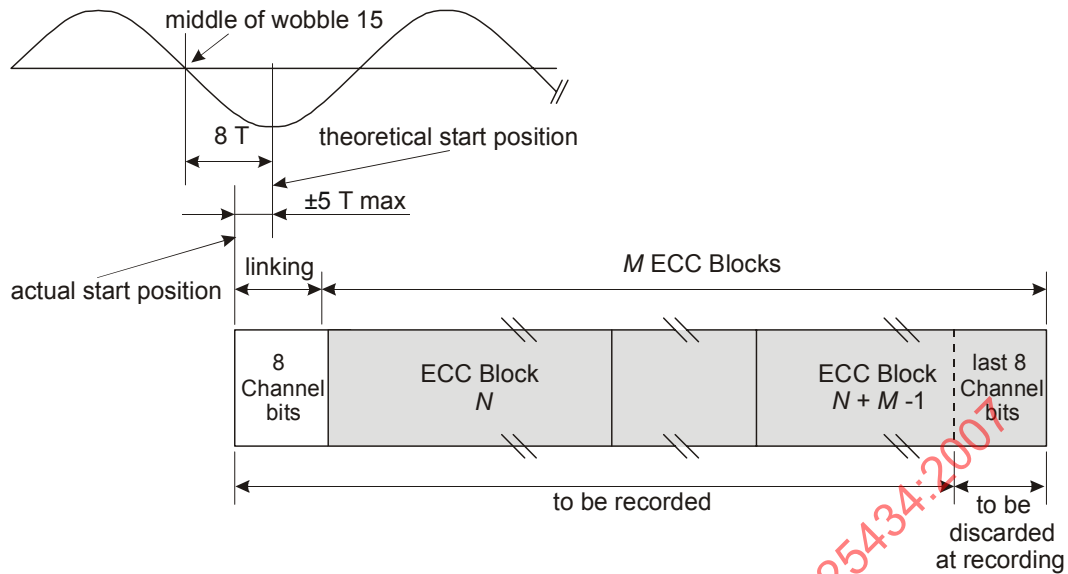

Figure 18 — Recording Unit

13.7.1 Recording Unit position

Each ECC Block, consisting of 16 Physical Sectors, shall correspond to 4 ADIP words (see 14.4.1.1). RUNs shall be mapped onto the structure of tracks (see 14.4), such that the Physical Sector Numbers (PSN), of which the 2 least significant bits have been discarded, correspond to the local Physical Address in ADIP (PAA). In mathematical form: $PSN = 4 \times PAA + i$, where $i = 0, 1, 2, \text{ or } 3$ (for example: PSNs (030000) to (030003) correspond to PAA (00C000)).

The reference for the theoretical start positions is wobble 15 following the ADIP word sync unit of the ADIP words of which the 2 least significant address bits are 00 (see 14.4.1.1 and Figure 22). The theoretical start position is 8 Channel bits after the nominal position of the zero crossing in the middle of the above mentioned wobble 15 of the wobble signal from Read channel 2.

The start of each recording shall be within ± 5 Channel bits of the theoretical start position. During writing the Channel bit clock shall be phase locked to the wobble frequency.

13.8 d.c. component suppression control

To ensure a reliable radial tracking and a reliable detection of the HF signals, the low frequency content of the stream of Channel bit patterns should be kept as low as possible. In order to achieve this, the Digital Sum Value (DSV, see 4.3) shall be kept as close to zero as possible. At the beginning of the modulation, the DSV shall be set to 0.

The different ways of diminishing the current value of the DSV are as follows:

- Choice of SYNC Codes between Primary or Secondary SYNC Codes.
- For the 8-bit bytes in the range 0 to 87, the Substitution table offers an alternative 16-bit Code Word for all States.
- For the 8-bit bytes in the range 88 to 255, when the prescribed State is 1 or 4, then the 16-bit Code Word can be chosen either from State 1 or from State 4, so as to ensure that the RLL requirement is met.

In order to use these possibilities, two data streams, Stream 1 and Stream 2, are generated. Stream 1 shall start with the Primary SYNC Code and Stream 2 with the Secondary SYNC Code of the same category of SYNC Codes. As both streams are modulated individually, they generate a different DSV because of the difference between the bit patterns of the Primary and Secondary SYNC Codes.

In the cases b) and c), there are two possibilities to represent a 8-bit byte. The DSV of each stream is computed up to the 8-bit byte preceding the 8-bit byte for which there is this choice. The stream with the lowest $|DSV|$ is selected and duplicated to the other stream. Then, one of the representations of the next 8-bit byte is entered into Stream 1 and the other into Stream 2. This operation is repeated each time case b) or c) occurs.

Whilst case b) always occurs at the same pattern position in both streams, case c) may occur in one of the streams and not in the other because, for instance, the next State prescribed by the previous 8-bit byte can be 2 or 3 instead of 1 or 4. In that case the following 3-step procedure shall be applied:

- 1) Compare the $|DSV|$ s of both streams.
- 2) If the $|DSV|$ of the stream in which case c) occurs is smaller than that of the other stream, then the stream in which case c) has occurred is chosen and duplicated to the other stream. One of the representations of the next 8-bit byte is entered into this stream and the other into the other stream.
- 3) If the $|DSV|$ of the stream in which case c) has occurred is larger than that of the other stream, then case c) is ignored and the 8-bit byte is represented according to the prescribed State.

In both cases b) and c), if the $|DSV|$ s are equal, the decision to choose Stream 1 or Stream 2 is implementation-defined.

The procedure for case a) shall be as follows:

- 1) At the end of each Sync Frame, whether or not case b) and or case c) have occurred, the accumulated DSVs of both streams are compared. The stream with the lower $|DSV|$ is selected and duplicated to the other stream. Then the next Primary SYNC Code and the Secondary SYNC Code of the proper category are inserted each in one of the streams.

Optionally the procedure for case a) can be extended in the following way:

- 2) If the DSV at the end of the resulting Sync Frame is greater than + 63 or smaller than -64, then the SYNC Code at the beginning of the Sync Frame is changed from Primary to Secondary or vice versa. If this yields a smaller $|DSV|$, the change is permanent, if the $|DSV|$ is not smaller, the original SYNC Code is retained.

During the DSV computation, the actual values of the DSV may vary between -1 000 and +1 000, thus it is recommended that the count range for the DSV be at least from -1 024 to +1 023.

14 Track format

14.1 Track shape

The area in the Information Zone (see 10.7) shall contain tracks formed from a single spiral groove. Each track shall form a 360° turn of a continuous spiral. The shape of each track is determined by the requirements in Section 5. Recordings shall be made on the groove.

The tracks in the Information Zone contain a phase modulated sinusoidal deviation from the nominal centrelines, called wobble, which contains addressing information.

The tracks shall be continuous in the Information Zone.

The groove tracks shall start at a radius of 22,00 mm max.

and end at a radius of 58,75 mm min (see also Annex A).

14.2 Track path

On Layer 0 the track path shall be a continuous spiral from the inside (beginning of the Lead-in Zone) to the outside (end of the Middle Zone) when the disk rotates counter-clockwise as viewed from the optical head.

On Layer 1 the track path shall be a continuous spiral from the outside (beginning of the Middle Zone) to the inside (end of the Lead-out Zone) when the disk rotates counter-clockwise as viewed from the optical head.

14.3 Track pitch

The track pitch is the distance measured between the average track centrelines of adjacent tracks, measured in the radial direction. The track pitch shall be $0,74 \mu\text{m} \pm 0,03 \mu\text{m}$. The track pitch averaged over the Information Zone shall be $0,74 \mu\text{m} \pm 0,01 \mu\text{m}$.

14.4 Track layout

The wobble of the tracks is a sinusoidal deviation from the nominal centrelines, with a wavelength of $4,691 2 \mu\text{m} \pm 0,045 0 \mu\text{m}$ (equivalent to 32 Channel bits). The Total Harmonic Distortion (THD) of the oscillator for generating the wobble sine wave shall be ≤ -40 dB.

The wobble is phase modulated by inverting wobble cycles. The information contained in the wobble modulation is called Address-in-Pregroove or ADIP (see 14.4.1.1).

14.4.1 ADIP information

The data to be recorded onto the disk must be aligned with the ADIP information modulated in the wobble. Therefore 93 wobbles shall correspond to 2 Sync Frames. Of each 93 wobbles, 8 wobbles are phase modulated with ADIP information (see Figure 19).

1 wobble equals 32 Channel bits (= 32T)

one ADIP unit = 8 modulated wobbles per 2 Sync Frames

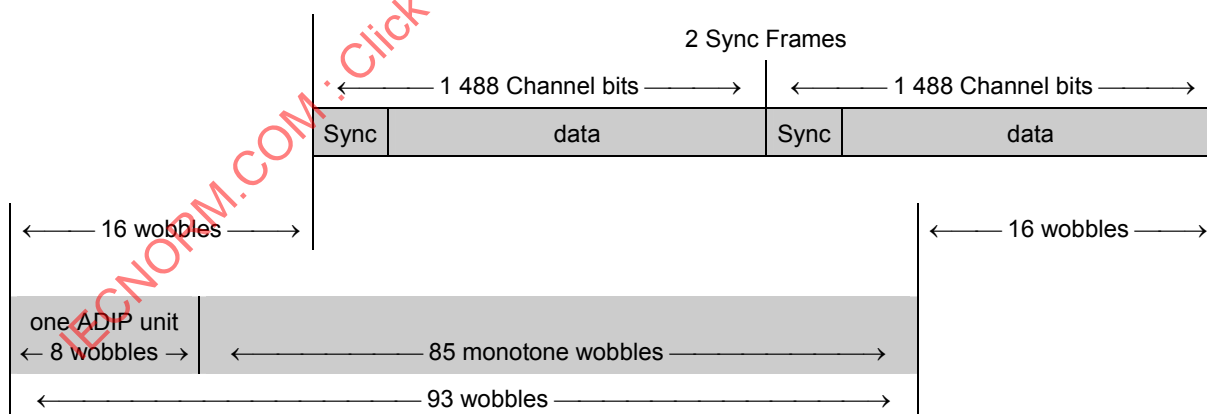

Figure 19 — General ADIP structure

14.4.1.1 ADIP word structure

52 ADIP units are grouped into one ADIP word each. This means that one ADIP word corresponds to $4 \times 13 \times 2$ Sync Frames \equiv 4 Physical Sectors.

Each ADIP word shall consist of: 1 ADIP sync unit + 51 ADIP data units (see Figure 20). ADIP sync unit = 4 inverted wobbles for word sync + 4 monotone wobbles. ADIP data unit = 1 inverted wobble for bit sync + 3 monotone wobbles + 4 wobbles representing one data bit (see 14.4.1.3).

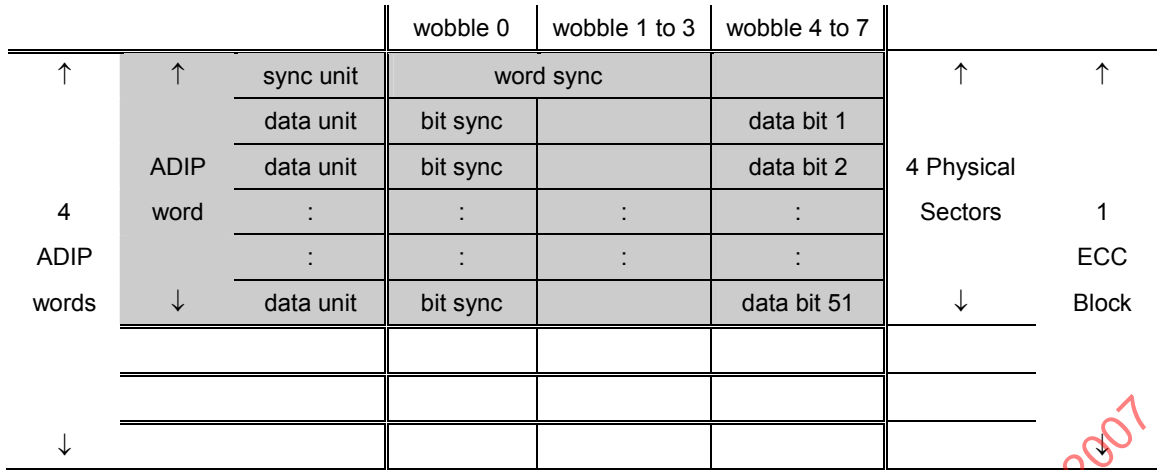

Figure 20 — ADIP word structure

The information contained in the data bits is as follows:

bit 1: this bit is **reserved** and shall be set to ZERO.

bits 2 to 23: these 22 bits contain a **Physical ADIP Address**.

Data bit 2 is the msb and data bit 23 is the lsb. The addresses increase by one for each next ADIP word. On layer 1 the Physical ADIP Addresses shall have the bit inverted values of the Physical ADIP Addresses at the same radial position on Layer 0.

NOTE In the following hexadecimal notations of addresses the two msb's shall be ignored.

The addresses in the Information Zone on Layer 0 shall be such that Physical ADIP Address (00C000), which is the first address corresponding to the Data Zone, is located at radius $24,00^{+0,00}_{-0,20}$ mm . Physical ADIP Address (08B5FF), which is the last address corresponding to the Data Zone on Layer 0, shall be located at radius 58,00 mm max (see also Annex A).

The addresses in the Information Zone on Layer 1 shall be such that Physical ADIP Address (FF3FFF), which is the last address corresponding to the Data Zone, is located at radius $24,00^{+0,00}_{-0,20}$ mm . Physical ADIP Address (F74A00), which is the first address corresponding to the Data Zone on Layer 1, shall be located at radius 58,00 mm max (see also Annex A).

bits 24 to 31: these 8 bits contain **auxiliary information** about the disk.

Bit 24 to 31 from 256 consecutive ADIP words, shall form one ADIP Aux Frame with 256 bytes of information. The first byte of each ADIP Aux Frame shall be located in an ADIP word with a Physical ADIP Address that is a multiple of 256 (Physical ADIP Address = (xxxx00)).

In the Lead-in/Lead-out Zone and the Inner Drive Areas of the disk the auxiliary bytes shall be used for storing Physical format information. The contents of the 256 bytes are defined in the Table 3 and 14.4.2.

In the Data Zone of the disk the auxiliary bytes may be used for storing Extended format information as defined in Annex B. If not used for such purpose all bytes shall be set to (00).

In the Middle Zones/Outer Drive Areas of the disk the auxiliary bytes shall be set to (00).

bits 32 to 51: these 20 bits contain **error correction parities** for the ADIP information (see 14.4.1.2).

14.4.1.2 ADIP error correction

For the ADIP error correction the ADIP data bits are grouped into 4-bit nibbles. The mapping of the data bits into the nibble array is defined in Figure 21. Bit 0 is a dummy bit, which shall be considered as set to ZERO for the error corrector.

nibble N ₀	bit 0	bit 1	bit 2	bit 3	↑ 6 nibbles ↓ ADIP address
nibble N ₁	bit 4	bit 5	:	:	
:	:	:	:	:	
:	bit 20	:	:	bit 23	
:	bit 24				
nibble N ₇	bit 28		:	bit 31	
nibble N ₈	bit 32	:	:	:	↑ 5 nibbles ↓ nibble based R-S ECC
:	:	:	:	:	
:	:	:	:	:	
:	:	:	:	:	
nibble N ₁₂	bit 48	bit 49	bit 50	bit 51	

Figure 21 — ADIP error correction structure

A nibble-based RS (13,8,6) code is constructed, of which the 5 parity nibbles N₈ to N₁₂, are defined by the remainder polynomial R(x):

$$R(x) = \sum_{i=8}^{12} N_i x^{12-i} = l(x) x^5 \text{ mod } G_{PA}(x)$$

where

$$l(x) = \sum_{i=0}^7 N_i x^{7-i} \quad \text{and} \quad G_{PA}(x) = \prod_{k=0}^4 (x + \alpha^k)$$

α is the primitive root 0010 of the primitive polynomial $P(x) = x^4 + x + 1$

All bits of the 5 parity nibbles N₈ to N₁₂ shall be inverted before recording.

14.4.1.3 ADIP modulation rules

The ADIP units are modulated by inverting some of the 8 wobble cycles:

- PW is a positive wobble, which shall start moving towards the inside of the disk.
- NW is a negative wobble, which shall start moving towards the outside of the disk.
- all monotone wobbles shall be PWs.

Modulation of the ADIP word sync:

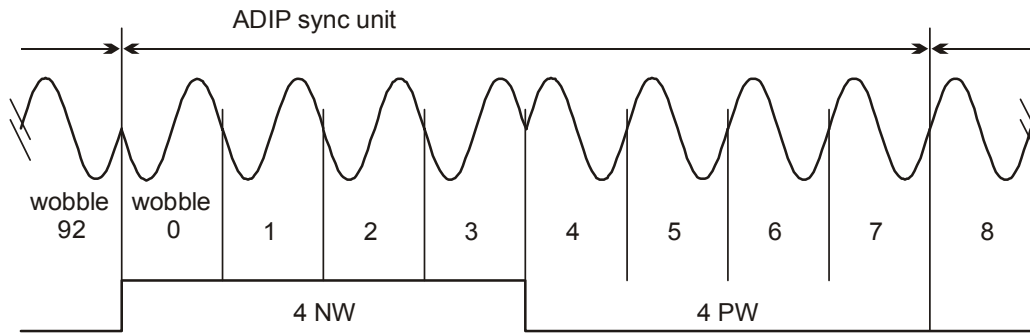

Modulation of an ADIP ZERO bit:

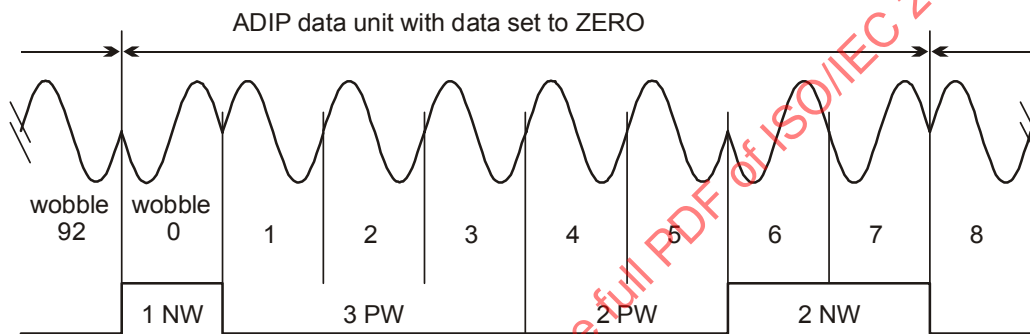

Modulation of an ADIP ONE bit:

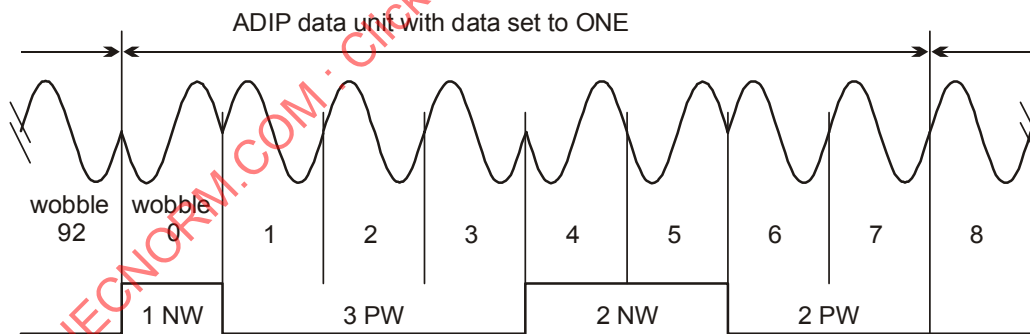

Figure 22 — ADIP modulation rules

14.4.2 Physical format information in ADIP

This information shall comprise the 256 bytes shown in Table 3. It contains disk information and values for the write strategy parameters to be used with the Optimum Power Control (OPC) algorithm to determine optimum laser power levels for writing (see Annex G and Annex I). The information is copied to the Control Data Zone (see 18.8.1) during finalization of the Lead-in Zone of the disk.

Because the recording characteristics of the two layers can be different, each layer shall be characterized by its own Physical format information. Therefore the ADIP Aux Frames on Layer 0, located in the Inner Drive Area 0 and the Lead-in Zone, shall contain the Physical format information for Layer 0 and the ADIP Aux Frames on Layer 1, located in the Inner Drive Area 1 and the Lead-out Zone, shall contain the Physical format information for Layer 1.

Bytes 0 to 30 in both ADIP Aux Frames are common and therefore shall be the same on both layers.

Unless specified otherwise, the definitions for all bytes of the ADIP Aux Frames for the two layers are the same. Only the values for the two layers may differ.

Table 3 — Physical format information

Byte number	Content	Number of bytes
0	Disk Category and Version Number	1
1	Disk size	1
2	Disk structure	1
3	Recording density	1
4 to 15	Data Zone allocation	12
16	General Flag bits	1
17	Disk Application Code	1
18	Extended Information indicators	1
19 to 26	Disk Manufacturer ID	8
27 to 29	Media Type ID	3
30	Product revision number	1
31	number of Physical format information bytes in use in ADIP up to byte 63	1
32	Primary recording velocity for the basic write strategy	1
33	Upper recording velocity for the basic write strategy	1
34	Wavelength λ_{IND}	1
35	normalized Write power dependency on Wavelength $(dP/d\lambda)/(P_{IND}/\lambda_{IND})$	1
36	Maximum read power at Primary velocity	1
37	P_{IND} at Primary velocity	1
38	β_{target} at Primary velocity	1
39	Maximum read power at Upper velocity	1
40	P_{IND} at Upper velocity	1
41	β_{target} at Upper velocity	1
42	$T_{top} (\geq 4T)$ first pulse duration for $cm^* \geq 4T$ at Primary velocity	1
43	$T_{top} (=3T)$ first pulse duration for $cm^* = 3T$ at Primary velocity	1
44	T_{mp} multi pulse duration at Primary velocity	1
45	T_{lp} last pulse duration at Primary velocity	1
46	$dT_{top} (\geq 4T)$ first pulse lead time for $cm^* \geq 4T$ at Primary velocity	1

* cm = current mark, ps = previous space (see also Annex G)

Byte number	Content	Number of bytes
47	$dT_{top} (=3T)$ first pulse lead time for $cm^* =3T$ at Primary velocity	1
48	dT_{le} first pulse leading edge shift for $ps^* =3T$ at Primary velocity	1
49	dT_{le} first pulse leading edge shift for $ps^* =4T$ at Primary velocity	1
50	dT_{le} first pulse leading edge shift for $ps^* =5T$ at Primary velocity	1
51	T_C end of cooling gap at Primary velocity	1
52	Reserved - All (00)	1
53	$T_{top} (\geq 4T)$ first pulse duration for $cm^* \geq 4T$ at Upper velocity	1
54	$T_{top} (=3T)$ first pulse duration for $cm^* =3T$ at Upper velocity	1
55	T_{mp} multi pulse duration at Upper velocity	1
56	T_{lp} last pulse duration at Upper velocity	1
57	$dT_{top} (\geq 4T)$ first pulse lead time for $cm^* \geq 4T$ at Upper velocity	
58	$dT_{top} (=3T)$ first pulse lead time for $cm^* =3T$ at Upper velocity	1
59	dT_{le} first pulse leading edge shift for $ps^* =3T$ at Upper velocity	1
60	dT_{le} first pulse leading edge shift for $ps^* =4T$ at Upper velocity	1
61	dT_{le} first pulse leading edge shift for $ps^* =5T$ at Upper velocity	1
62	T_C end of cooling gap at Upper velocity	1
63	Reserved - All (00)	1
64 to 95	Extended Information block 0	32
96 to 127	Extended Information block 1	32
128 to 159	Extended Information block 2	32
160 to 191	Extended Information block 3	32
192 to 223	Extended Information block 4	32
224 to 247	Extended Information block 5	24
248 to 255	Reserved for use in the Control Data Zone – All (00)	8

This version of this document specifies two types of disks, with different recording velocity ranges. The specific write parameters for each recording velocity range shall be specified in separate blocks (EI blocks, see 14.4.2.3). The following types of disks (characterized by the so-called X-speed) have now been defined and their ADIP shall contain the EI Blocks as indicated in Table 4.

Table 4 — Types of disks

type of disc	basic write strategy bytes 32 to 63 (2,4x speed)	3,3x+ write strategy EI block Format 4 (3,3x ~ 8x speed)	remarks
"2,4x"	+	–	this disc shall be suited for a recording speed of 9,20 m/s only
"8x"	+	+	this disc shall be suited for recording speeds of 9.20 m/s and 12,7 ~ 30,7 m/s

+ shall be present – shall not be used

* cm = current mark, ps = previous space (see also Annex G)

14.4.2.1 General information - Bytes 0 to 31**Byte 0 - Disk Category and Version Number**

Bits b_7 to b_4 shall specify the Disk Category,

bit b_7 shall be set to 1 indicating a disk according to the +R/+RW Format (see clause 3),

bit b_6 shall be set to 1 indicating a dual layer disk,

bits b_5 and b_4 shall be set 10 indicating a +R disk.

Bits b_3 to b_0 shall specify the Version Number,

they shall be set to 0001 indicating this Standard.

This Version Number identifies amongst others the definitions of the data in bytes 32 to 63. Drives not acquainted with the specific Version Number of a disk should not try to record on that disk using the information in bytes 32 to 63, which bytes contain the basic write strategy parameters (see Annex Q).

NOTE Version number 0000 can be used for identification of test discs during further development of the system. Such test discs might not contain the correct Physical format information in their ADIP Aux Frames.

Byte 1 - Disk size and maximum transfer rate

Bits b_7 to b_4 shall specify the disk size,
they shall be set to 0000, indicating a 120 mm disk (see also Annex A).

Bits b_3 to b_0 shall specify the maximum read transfer rate,
they shall be set to 1111 indicating no maximum read transfer rate is specified.

Byte 2 - Disk structure

Bit b_7 shall be set to 0.

Bits b_6 to b_5 shall be set to 01, indicating two recording layers per side.

Bit b_4 shall be set to 1, indicating OTP mode.

Bits b_3 to b_0 shall specify the type of the recording layer(s):
they shall be set to 0010, indicating a write-once recording layer.

Byte 3 - Recording density

Bits b_7 to b_4 shall specify the average Channel bit length in the Information Zone,
they shall be set to 0001, indicating 0,147 μm .

Bits b_3 to b_0 shall specify the average track pitch,
they shall be set to 0000, indicating an average track pitch of 0,74 μm .

Bytes 4 to 15 - Data Zone allocation

- Byte 4 shall be set to (00).
- Bytes 5 to 7 shall be set to (030000) to specify PSN 196 608 of the first Physical Sector of the Data Zone.
- Byte 8 shall be set to (00).
- Bytes 9 to 11 shall be set to (FCFFFF) to specify PSN 16 580 607 as the last possible Physical Sector of the Data Zone.
- Byte 12 shall be set to (00).
- Bytes 13 to 15 shall be set to (22D7FF) to specify PSN 2 283 519 as the last possible Physical Sector of the Data Zone on Layer 0 (see also Annex A).

Byte 16 – General Flag bits

- Bit b₇ shall be set to ZERO.
- Bit b₆ shall specify if the disk contains Extended format information in the ADIP Aux Frames in the Data Zone related to the VCPS copy protection system,
 - shall be set to 0, indicating no Extended format information for VCPS is present,
 - shall be set to 1, indicating the Data Zone contains Extended format information for VCPS as defined in Annex B and the VCPS System Description (see Annex P).
- Bit b₅ is reserved for use in the Control Data Zone and shall be set to ZERO.
- Bits b₄ to b₀ are reserved and shall be set to 0 0000.

Byte 17 – Disk Application Code

This byte can identify disks that are restricted to be used for special applications only. Drives not able to identify the particular application related to a specific Disk Application Code or not able to act according to the rules as defined for this particular application are not allowed to write on a disk with such a code.

- (00) identifies a disk for General Purpose use (no restrictions, all drives are allowed to write on a disk carrying this code),
- all other codes are reserved.

Byte 18 – Extended Information indicators

- Bits b₇ to b₆ are reserved and shall be set to 00.
- Bits b₅ to b₀ each of these bits shall indicate the presence of an Extended Information block. Bit b_i shall be set to 1 if Extended Information block i, consisting of bytes (64 + i×32) to (95 + i×32), is in use. Else bit b_i shall be set to 0.

Bytes 19 to 26 – Disk Manufacturer ID

These 8 bytes shall identify the manufacturer of the disk. This name shall be represented by characters from the G0 set + SPACE according to Standard ISO/IEC 4873. Trailing bytes not used shall be set to (00).

If the Disk Manufacturer ID is not used these 8 bytes shall be set to (00).

Bytes 27 to 29 – Media Type ID

Disk manufacturers can have different types of media, which shall be specified by these 3 bytes. The specific type of disk is denoted in this field by characters from the G0 set + SPACE according to Standard ISO/IEC 4873. Trailing bytes not used shall be set to (00).

If the Media Type ID is not used these 3 bytes shall be set to (00).

NOTE Disks with different characteristics shall be identified by different and unique combinations of Disk Manufacturer ID / Media Type ID. Therefore the content of bytes 19 to 29 shall be approved by the licensors of the +R system.

Byte 30 – Product revision number / Layer structure

Bits b_5 to b_0 of this byte shall identify the product revision number in binary notation.

Bits b_7 to b_6 shall indicate the type of Layer structure (see 4.10)

- 00 indicates that the Layer structure is not specified,
- 01 indicates a disc with an “inverted-stack” or equivalent Layer structure,
- 10 indicates a disc with a “2P” or equivalent Layer structure,
- 11 reserved.

All disks with the same Disk Manufacturer ID and the same Media Type ID, regardless of Product revision number / Layer structure indications, must have the same recording properties (only minor differences are allowed: Product revision numbers shall be irrelevant for recorders). The content of this byte can be chosen freely by the disk manufacturer.

If not used this byte shall be set to (00).

Byte 31 – number of Physical format information bytes in use in ADIP up to byte 63

This byte forms one 8-bit binary number indicating the number of bytes actually in use for the basic Physical format information (in bytes 0 to 63). It shall be set to (40) indicating that the first 64 bytes of the Physical format information are used.

14.4.2.2 Basic write strategy parameters - Bytes 32 to 63**Byte 32 – Primary recording velocity for the basic write strategy**

This byte indicates the lowest recording velocity of the disk for the parameters as defined in bytes 34 to 63 in this Physical format information. This recording velocity is equal to about 2,4 times the Reference velocity and shall be specified as a number n such that

$$n = 4 \times v_{\text{primary,basic}} \quad (n \text{ rounded off to an integral value})$$

It shall be

set to (25) indicating a Primary writing speed of about 9,25 m/s.

Byte 33 – Upper recording velocity for the basic write strategy

This byte indicates the highest recording velocity of the disk for the parameters as defined in bytes 34 to 63 in this Physical format information. This recording velocity shall be specified as a number n such that

$$n = 4 \times v_{\text{upper,basic}} \quad (n \text{ rounded off to an integral value})$$

It shall be

set to (25) indicating a Upper writing speed of about 9,25 m/s.

(In future, when higher recording speeds which are compatible with this write strategy become possible, higher values can be allowed.)

Byte 34 – Wavelength λ_{IND}

This byte shall specify the laser wavelength in nanometers at which the optimum write parameters in the following bytes are specified, as a number n such that

$$n = \text{Wavelength} - 600$$

For this version of the +R DL system, n shall be equal to (37) indicating that λ_{IND} is 655 nanometers.

Byte 35 – Normalized Write power dependency on Wavelength

This byte shall specify the average write power dependency on the wavelength normalized by the ratio of P_{IND} and λ_{IND} (see 30.3.3 and Annex K), as a number n such that

$$n = (dP/d\lambda)/(P_{IND}/\lambda_{IND})$$

Byte 36 - Maximum read power, P_r at Primary velocity

This byte shall specify the maximum read power P_r in milliwatts at Primary velocity as a number n such that

$$n = 20 \times (P_r - 0,7)$$

Byte 37 - P_{IND} at Primary velocity

P_{IND} is the starting value for the determination of P_{wo} used in the OPC algorithm, see Annex I and Annex K.

This byte shall specify the indicative value P_{IND} of P_{wo} in milliwatts at Primary velocity and λ_{IND} as a number n such that

$$n = 4 \times (P_{IND} - 10)$$

Byte 38 - β_{target} at Primary velocity

This byte shall specify the target value for β , β_{target} at Primary velocity used in the OPC algorithm (see Annex I) as a number n such that

$$n = 100 \times (\beta_{target} + 1)$$

Byte 39 - Maximum read power, P_r at Upper velocity

This byte shall specify the maximum read power P_r in milliwatts at Upper velocity as a number n such that

$$n = 20 \times (P_r - 0,7)$$

Byte 40 - P_{IND} at Upper velocity

P_{IND} is the starting value for the determination of P_w used in the OPC algorithm, see Annex I and Annex K.

This byte shall specify the indicative value P_{IND} of P_w in milliwatts at Upper velocity and λ_{IND} as a number *n* such that

$$n = 4 \times (P_{IND} - 10)$$

Byte 41 - β_{target} at Upper velocity

This byte shall specify the target value for β, β_{target} at Upper velocity used in the OPC algorithm (see Annex I) as a number *n* such that

$$n = 100 \times (\beta_{target} + 1)$$

Byte 42 – T_{top} (≥4T) first pulse duration for current mark ≥4T at Primary velocity

This byte shall specify the duration of the first pulse of the multi pulse train when the current mark is a 4T or greater mark for recording at Primary velocity (see Annex G.1). The value is expressed in fractions of the Channel bit clock period as a number *n* such that

$$n = 16 \times \frac{T_{top}}{T_W} \quad \text{and} \quad 4 \leq n \leq 40$$

Byte 43 – T_{top} (=3T) first pulse duration for current mark =3T at Primary velocity

This byte shall specify the duration of the first pulse of the multi pulse train when the current mark is a 3T mark for recording at Primary velocity (see Annex G.1). The value is expressed in fractions of the Channel bit clock period as a number *n* such that

$$n = 16 \times \frac{T_{top}}{T_W} \quad \text{and} \quad 4 \leq n \leq 40$$

Byte 44 – T_{mp} multi pulse duration at Primary velocity

This byte shall specify the duration of the 2nd pulse through the 2nd to last pulse of the multi pulse train for recording at Primary velocity (see Annex G.1). The value is expressed in fractions of the Channel bit clock period as a number *n* such that

$$n = 16 \times \frac{T_{mp}}{T_W} \quad \text{and} \quad 4 \leq n \leq 14$$

Byte 45 – T_{lp} last pulse duration at Primary velocity

This byte shall specify the duration of the last pulse of the multi pulse train when the current mark is a 4T or greater mark for recording at Primary velocity (see Annex G.1). The value is expressed in fractions of the Channel bit clock period as a number *n* such that

$$n = 16 \times \frac{T_{lp}}{T_W} \quad \text{and} \quad 4 \leq n \leq 24$$

Byte 46 – $dT_{top} (\geq 4T)$ first pulse lead time for current mark $\geq 4T$ at Primary velocity

When the current mark is a 4T or greater mark, this byte shall specify the lead time of the first pulse of the multi pulse train relative to the trailing edge of the second Channel bit of the data pulse, for recording at Primary velocity (see Annex G.1). The value is expressed in fractions of the Channel bit clock period as a number n such that

$$n = 16 \times \frac{dT_{top}}{T_W} \text{ and } 0 \leq n \leq 24$$

Byte 47 – $dT_{top} (=3T)$ first pulse lead time for current mark $=3T$ at Primary velocity

When the current mark is a 3T mark, this byte shall specify the lead time of the first pulse of the multi pulse train relative to the trailing edge of the second Channel bit of the data pulse, for recording at Primary velocity (see Annex G.1). The value is expressed in fractions of the Channel bit clock period as a number n such that

$$n = 16 \times \frac{dT_{top}}{T_W} \text{ and } 0 \leq n \leq 24$$

Byte 48 – dT_{le} first pulse leading edge shift for previous space $=3T$ at Primary velocity

This byte shall specify the leading edge shift for the first pulse of the multi pulse train when the previous space was a 3T space for recording at Primary velocity (see Annex G.1). The value is expressed in fractions of the Channel bit clock period as a number n such that

$$n = 16 \times \frac{dT_{le}}{T_W} \text{ and } 0 \leq n \leq 4$$

Byte 49 – dT_{le} first pulse leading edge shift for previous space $=4T$ at Primary velocity

This byte shall specify the leading edge shift for the first pulse of the multi pulse train when the previous space was a 4T space for recording at Primary velocity (see Annex G.1). The value is expressed in fractions of the Channel bit clock period as a number n such that

$$n = 16 \times \frac{dT_{le}}{T_W} \text{ and } 0 \leq n \leq 4$$

Byte 50 – dT_{le} first pulse leading edge shift for previous space $=5T$ at Primary velocity

This byte shall specify the leading edge shift for the first pulse of the multi pulse train when the previous space was a 5T space for recording at Primary velocity (see Annex G.1). The value is expressed in fractions of the Channel bit clock period as a number n such that

$$n = 16 \times \frac{dT_{le}}{T_W} \text{ and } 0 \leq n \leq 4$$

Byte 51 – T_C end of cooling gap at Primary velocity

This byte shall specify the end of the cooling gap for recording at Primary velocity (see Annex G.1). The value is expressed in fractions of the Channel bit clock period as a number n such that

$$n = 16 \times \frac{T_C}{T_W} \text{ and } 16 \leq n \leq 32$$

Byte 52 - Reserved - (00)

This byte shall be set to (00).

Byte 53 – T_{top} ($\geq 4T$) first pulse duration for current mark $\geq 4T$ at Upper velocity

This byte shall specify the duration of the first pulse of the multi pulse train when the current mark is a 4T or greater mark for recording at Upper velocity (see Annex G.1). The value is expressed in fractions of the Channel bit clock period as a number n such that

$$n = 16 \times \frac{T_{top}}{T_W} \text{ and } 4 \leq n \leq 40$$

Byte 54 – T_{top} (3) first pulse duration for current mark =3T at Upper velocity

This byte shall specify the duration of the first pulse of the multi pulse train when the current mark is a 3T mark for recording at Upper velocity (see Annex G.1). The value is expressed in fractions of the Channel bit clock period as a number n such that

$$n = 16 \times \frac{T_{top}}{T_W} \text{ and } 4 \leq n \leq 40$$

Byte 55 – T_{mp} multi pulse duration at Upper velocity

This byte shall specify the duration of the 2nd pulse through the 2nd to last pulse of the multi pulse train for recording at Upper velocity (see Annex G.1). The value is expressed in fractions of the Channel bit clock period as a number n such that

$$n = 16 \times \frac{T_{mp}}{T_W} \text{ and } 4 \leq n \leq 44$$

Byte 56 – T_{lp} last pulse duration at Upper velocity

This byte shall specify the duration of the last pulse of the multi pulse train when the current mark is a 4T or greater mark for recording at Upper velocity (see Annex G.1). The value is expressed in fractions of the Channel bit clock period as a number n such that

$$n = 16 \times \frac{T_{lp}}{T_W} \text{ and } 4 \leq n \leq 24$$

Byte 57 – dT_{top} ($\geq 4T$) first pulse lead time for current mark $\geq 4T$ at Upper velocity

When the current mark is a 4T or greater mark, this byte shall specify the lead time of the first pulse of the multi pulse train relative to the trailing edge of the second Channel bit of the data pulse, for recording at Upper velocity (see Annex G.1). The value is expressed in fractions of the Channel bit clock period as a number n such that

$$n = 16 \times \frac{dT_{top}}{T_W} \text{ and } 0 \leq n \leq 24$$

Byte 58 – dT_{top} (=3T) first pulse lead time for current mark =3T at Upper velocity

When the current mark is a 3T mark, this byte shall specify the lead time of the first pulse of the multi pulse train relative to the trailing edge of the second Channel bit of the data pulse, for recording at Upper velocity (see Annex G.1). The value is expressed in fractions of the Channel bit clock period as a number n such that

$$n = 16 \times \frac{dT_{top}}{T_W} \text{ and } 0 \leq n \leq 24$$

Byte 59 – dT_{le} first pulse leading edge shift for previous space =3T at Upper velocity

This byte shall specify the leading edge shift for the first pulse of the multi pulse train when the previous space was a 3T space for recording at Upper velocity (see Annex G.1). The value is expressed in fractions of the Channel bit clock period as a number n such that

$$n = 16 \times \frac{dT_{le}}{T_W} \text{ and } 0 \leq n \leq 4$$

Byte 60 – dT_{le} first pulse leading edge shift for previous space =4T at Upper velocity

This byte shall specify the leading edge shift for the first pulse of the multi pulse train when the previous space was a 4T space for recording at Upper velocity (see Annex G.1). The value is expressed in fractions of the Channel bit clock period as a number n such that

$$n = 16 \times \frac{dT_{le}}{T_W} \text{ and } 0 \leq n \leq 4$$

Byte 61 – dT_{le} first pulse leading edge shift for previous space =5T at Upper velocity

This byte shall specify the leading edge shift for the first pulse of the multi pulse train when the previous space was a 5T space for recording at Upper velocity (see Annex G.1). The value is expressed in fractions of the Channel bit clock period as a number n such that

$$n = 16 \times \frac{dT_{le}}{T_W} \text{ and } 0 \leq n \leq 4$$

Byte 62 – T_C end of cooling gap at Upper velocity

This byte shall specify the end of the cooling gap for recording at Upper velocity (see Annex G.1). The value is expressed in fractions of the Channel bit clock period as a number n such that

$$n = 16 \times \frac{T_C}{T_W} \text{ and } 16 \leq n \leq 32$$

Byte 63 - Reserved - (00)

This byte shall be set to (00).

14.4.2.3 Extended Information blocks - Bytes (64 + i×32) to (95 + i×32)

(with $i = 0$ to 5)

Extended Information (EI) blocks are meant to facilitate future extensions. Each such block consists of 32 bytes. These bytes can hold for instance parameters for alternative write strategies or other advanced parameters. If a set of parameters does not fit in one Extended Information block, additional continuation blocks can be added, which additional blocks are identified by a Continuation bit.

The presence of an Extended Information block shall be indicated by the appropriate bit in byte 18. If an Extended Information block is not used, all 32 bytes shall be set to (00).

Byte (64 + i×32) Extended Information block i Format number/Continuation bit

Bits b_6 to b_0 indicate the Format number which identifies the definitions of the data in bytes (65 + i×32) to (95 + i×32).

If bit b_7 is set to ONE, the related Extended Information block is not an independent block but a continuation of the preceding Extended Information block. The Format number in a continuation block shall be the same as the Format number in the preceding Extended Information block.

A disk can have several Extended Information blocks. The contents of blocks with different Format numbers have to be interpreted each according to their respective definitions. The contents of blocks with the same Format number are interpreted in the same way; the parameters specified in these blocks however can have different values.

Drives not acquainted with the specific Format number in block i, should not use the parameters in this Extended Information block (see Annex Q).

NOTE The contents of an EI block are identified by the Format number of the block only. The position of the EI block in the ADIP Aux Frame is irrelevant for this, so an EI block with Format number n could be allocated at any position i. Therefore drives should always check the Format numbers in the EI blocks to be sure that the write strategies are correctly interpreted.

Bytes (65 + i×32) to (95 + i×32)

Each parameter set defined for these bytes shall be identified by a unique Format number.

Bytes 248 to 255 - Reserved for use in the Control Data Zone

These bytes shall be set to (00).

14.4.2.3.1 Extended information for the “3,3x+” write strategy

These Extended Information blocks specify the parameters for a write strategy usable at speeds of 3,3 times the basic DVD speed (3,3×3,83 m/s) up to 8 times the basic DVD speed (8×3,83 m/s)). The write strategy used at these speeds is a so-called “Castle” write strategy as defined in Annex G.2.

Because of too high rotational speeds at the inner side, the write strategy parameters for the Upper velocity shall be determined at the outer diameter of the disc (see 9.5).

If the disc can not be recorded under these “3,3x+” conditions, these EI blocks shall not be used (all bytes set to (00) and related Extended Information indicator bit set to ZERO).

Byte 18 – Extended Information indicators

This byte shall be set to xxxx xx11 indicating Extended Information block 0 and block 1 are in use.

Table 5 — Extended Information block 0

Byte number	Content	Number of bytes
64	Continuation bit / Format number	1
65	Reserved - set to (00)	1
66	Lower recording velocity for the parameter set in these EI blocks	1
67	Upper recording velocity for the parameter set in these EI blocks	1
68	Intermediate recording velocity for the parameter set in these EI blocks	1
69	Maximum read power at Lower velocity	1
70	P_{IND} at Lower velocity	1
71	β_{target} at Lower velocity	1
72	dPw power enhancement at Lower velocity	1
73	T_{I3} write pulse duration for 3T marks at Lower velocity	1
74	T_{top} duration of power enhancement at Lower velocity	1
75	$T_{end} (\geq 5T)$ duration of power enhancement for $cm \geq 5T$ at Lower velocity	1
76	$T_{end} (=4T)$ duration of power enhancement for $cm = 4T$ at Lower velocity	1
77	T_C end of cooling gap at Lower velocity	1
78	dT_{le} write pulse leading edge shift for $ps = 3T$ at Lower velocity	1
79	dT_{le} write pulse leading edge shift for $ps = 4T$ at Lower velocity	1
80	dT_{le} write pulse leading edge shift for $ps = 5T$ at Lower velocity	1
81	Reserved - set to (00)	1
82	Maximum read power at Upper velocity	1
83	P_{IND} at Upper velocity	1
84	β_{target} at Upper velocity	1
85	dPw power enhancement at Upper velocity	1
86	T_{I3} write pulse duration for 3T marks at Upper velocity	1
87	T_{top} duration of power enhancement at Upper velocity	1
88	$T_{end} (\geq 5T)$ duration of power enhancement for $cm \geq 5T$ at Upper velocity	1
89	$T_{end} (=4T)$ duration of power enhancement for $cm = 4T$ at Upper velocity	1
90	T_C end of cooling gap at Upper velocity	1
91	dT_{le} write pulse leading edge shift for $ps = 3T$ at Upper velocity	1
92	dT_{le} write pulse leading edge shift for $ps = 4T$ at Upper velocity	1
93	dT_{le} write pulse leading edge shift for $ps = 5T$ at Upper velocity	1
94	Reserved - set to (00)	1
95	P_{upper}/P_{lower} ratio	1

Table 6 — Extended Information block 1

Byte number	Content	Number of bytes
96	Continuation bit / Format number	1
97	Reserved - set to (00)	1
98	Maximum read power at Intermediate velocity	1
99	P_{IND} at Intermediate velocity	1
100	β_{target} at Intermediate velocity	1
101	dPw power enhancement at Intermediate velocity	1
102	T_{I3} write pulse duration for 3T marks at Intermediate velocity	1
103	T_{top} duration of power enhancement at Intermediate velocity	1
104	$T_{end} (\geq 5T)$ duration of power enhancement for $cm \geq 5T$ at Intermediate velocity	1
105	$T_{end} (=4T)$ duration of power enhancement for $cm =4T$ at Intermediate velocity	1
106	T_C end of cooling gap at Intermediate velocity	1
107	dT_{le} write pulse leading edge shift for $ps =3T$ at Intermediate velocity	1
108	dT_{le} write pulse leading edge shift for $ps =4T$ at Intermediate velocity	1
109	dT_{le} write pulse leading edge shift for $ps =5T$ at Intermediate velocity	1
110 to 127	Reserved - All (00)	18

Byte 64 - Extended Information block 0 Continuation bit / Format number

This byte shall be set to 0000 0100, indicating Format 4 and this block not being a continuation block, for which bytes 65 to 95 have the following meaning:

Byte 65 - Reserved

This byte is reserved and shall be set to all (00).

Byte 66 – Lower recording velocity for the parameter set in these EI blocks

This byte indicates the lowest recording velocity of the disc for the parameters as defined in these EI blocks. This recording velocity shall be specified as a number n such that

$$n = 4 \times v_{Lower, EI 1} \text{ (} n \text{ rounded off to an integral value)}$$

It shall be

set to (33) indicating a Lower writing speed of about 12,75 m/s (3,3×).

Byte 67 – Upper recording velocity for the parameter set in these EI blocks

This byte indicates the highest recording velocity of the disc for the parameters as defined in these EI blocks. This recording velocity shall be specified as a number n such that

$$n = 4 \times v_{Upper, EI 1} \text{ (} n \text{ rounded off to an integral value)}$$

It shall be

set to (7B) indicating an Upper writing speed of about 30,75 m/s (8×). (In future, when higher recording speeds which are compatible with this write strategy become possible, higher values can be allowed.)

Byte 68 – Intermediate recording velocity for the parameter set in these EI blocks

This byte indicates the intermediate recording velocity of the disc for the parameters as defined in these EI blocks. This recording velocity shall be specified as a number n such that

$$n = 4 \times v_{Upper, EI 1} \text{ (} n \text{ rounded off to an integral value)}$$

It shall be

set to (5C) indicating an Intermediate writing speed of about 23,00 m/s (6×).

Byte 69 - Maximum read power, P_r at Lower velocity

This byte shall specify the maximum read power P_r in milliwatts at Lower velocity as a number n such that

$$n = 20 \times (P_r - 0,7)$$

Byte 70 - P_{IND} at Lower velocity

P_{IND} is the starting value for the determination of P_{wo} used in the OPC algorithm, see Annex I and Annex K.

This byte shall specify the indicative value P_{IND} of P_{wo} in milliwatts at Lower velocity and λ_{IND} as a number n such that

$$n = 3 \times (P_{IND} - 5)$$

Byte 71 - β_{target} at Lower velocity

This byte shall specify the target value for β , β_{target} at Lower velocity used in the OPC algorithm (see Annex I) as a number n such that

$$n = 100 \times (\beta_{target} + 1)$$

Byte 72 - dPw power enhancement at Lower velocity

This byte shall specify the additional power for the 3T write pulse and for the beginning and end of all other write pulses (see Annex G.2) at Lower velocity as a number n such that

$$n = 200 \times dPw / P_{wo} \text{ and } 0 \leq n \leq 255$$

Byte 73 – T_{I3} write pulse duration for 3T marks at Lower velocity

This byte shall specify the duration of the write pulse when the current mark is a 3T mark for recording at Lower velocity (see Annex G.2). The value is expressed in fractions of the Channel bit clock period as a number n such that

$$n = 16 \times \frac{T_{I3}}{T_W} \text{ and } 16 \leq n \leq 48$$

Byte 74 – T_{top} duration of power enhancement at Lower velocity

This byte shall specify the duration of the power enhancement at the beginning of each write pulse when the current mark is a 4T or greater mark for recording at Lower velocity (see Annex G.2). The value is expressed in fractions of the Channel bit clock period as a number n such that

$$n = 16 \times \frac{T_{top}}{T_W} \quad \text{and} \quad 4 \leq n \leq 32$$

Byte 75 – $T_{end} (\geq 5T)$ duration of power enhancement for $cm \geq 5T$ at Lower velocity

This byte shall specify the duration of the power enhancement at the end of each write pulse when the current mark is a 5T or greater mark for recording at Lower velocity (see Annex G.2). The value is expressed in fractions of the Channel bit clock period as a number n such that

$$n = 16 \times \frac{T_{end}}{T_W} \quad \text{and} \quad 4 \leq n \leq 32$$

Byte 76 – $T_{end} (=4T)$ duration of power enhancement for $cm = 4T$ at Lower velocity

This byte shall specify the duration of the power enhancement at the end of each write pulse when the current mark is a 4T mark for recording at Lower velocity (see Annex G.2). The value is expressed in fractions of the Channel bit clock period as a number n such that

$$n = 16 \times \frac{T_{end}}{T_W} \quad \text{and} \quad 4 \leq n \leq 32$$

Byte 77 – T_C end of cooling gap at Lower velocity

This byte shall specify the end of the cooling gap for recording at Lower velocity (see Annex G.2). The value is expressed in fractions of the Channel bit clock period as a number n such that

$$n = 16 \times \frac{T_C}{T_W} \quad \text{and} \quad 16 \leq n \leq 32$$

Byte 78 – dT_{le} write pulse leading edge shift for previous space =3T at Lower velocity

This byte shall specify the leading edge shift for the write pulse when the previous space was a 3T space for recording at Lower velocity (see Annex G.2). The value is expressed in fractions of the Channel bit clock period as a number n such that

$$n = 16 \times \frac{dT_{le}}{T_W} \quad \text{and} \quad 0 \leq n \leq 4$$

Byte 79 – dT_{le} write pulse leading edge shift for previous space =4T at Lower velocity

This byte shall specify the leading edge shift for the write pulse when the previous space was a 4T space for recording at Lower velocity (see Annex G.2). The value is expressed in fractions of the Channel bit clock period as a number n such that

$$n = 16 \times \frac{dT_{le}}{T_W} \quad \text{and} \quad 0 \leq n \leq 4$$

Byte 80 – dT_{le} write pulse leading edge shift for previous space =5T at Lower velocity

This byte shall specify the leading edge shift for the write pulse when the previous space was a 5T space for recording at Lower velocity (see Annex G.2). The value is expressed in fractions of the Channel bit clock period as a number n such that

$$n = 16 \times \frac{dT_{le}}{T_W} \quad \text{and} \quad 0 \leq n \leq 4$$

Byte 81 - Reserved - All (00)

These bytes shall be set to all (00).

Byte 82 - Maximum read power, P_r at Upper velocity

This byte shall specify the maximum read power P_r in milliwatts at Upper velocity as a number n such that

$$n = 20 \times (P_r - 0,7)$$

Byte 83 - P_{IND} at Upper velocity

P_{IND} is the starting value for the determination of P_{wo} used in the OPC algorithm, see Annex I and Annex K.

This byte shall specify the indicative value P_{IND} of P_{wo} in milliwatts at Upper velocity and λ_{IND} as a number n such that

$$n = 3 \times (P_{IND} - 5)$$

Byte 84 - β_{target} at Upper velocity

This byte shall specify the target value for β , β_{target} at Upper velocity used in the OPC algorithm (see Annex I) as a number n such that

$$n = 100 \times (\beta_{target} + 1)$$

Byte 85 - dP_w power enhancement at Upper velocity

This byte shall specify the additional power for the 3T write pulse and for the beginning and end of all other write pulses (see Annex G.2) at Upper velocity as a number n such that

$$n = 200 \times dP_w / P_{wo} \quad \text{and} \quad 0 \leq n \leq 255$$

Byte 86 – T_{I3} write pulse duration for 3T marks at Upper velocity

This byte shall specify the duration of the write pulse when the current mark is a 3T mark for recording at Upper velocity (see Annex G.2). The value is expressed in fractions of the Channel bit clock period as a number n such that

$$n = 16 \times \frac{T_{I3}}{T_W} \quad \text{and} \quad 16 \leq n \leq 48$$

Byte 87 – T_{top} duration of power enhancement at Upper velocity

This byte shall specify the duration of the power enhancement at the beginning of each write pulse when the current mark is a 4T or greater mark for recording at Upper velocity (see Annex G.2). The value is expressed in fractions of the Channel bit clock period as a number n such that

$$n = 16 \times \frac{T_{top}}{T_W} \quad \text{and} \quad 4 \leq n \leq 32$$

Byte 88 – $T_{end} (\geq 5T)$ duration of power enhancement for $cm \geq 5T$ at Upper velocity

This byte shall specify the duration of the power enhancement at the end of each write pulse when the current mark is a 5T or greater mark for recording at Upper velocity (see Annex G.2). The value is expressed in fractions of the Channel bit clock period as a number n such that

$$n = 16 \times \frac{T_{end}}{T_W} \quad \text{and} \quad 4 \leq n \leq 32$$

Byte 89 – $T_{end} (=4T)$ duration of power enhancement for $cm = 4T$ at Upper velocity

This byte shall specify the duration of the power enhancement at the end of each write pulse when the current mark is a 4T mark for recording at Upper velocity (see Annex G.2). The value is expressed in fractions of the Channel bit clock period as a number n such that

$$n = 16 \times \frac{T_{end}}{T_W} \quad \text{and} \quad 4 \leq n \leq 32$$

Byte 90 – T_C end of cooling gap at Upper velocity

This byte shall specify the end of the cooling gap for recording at Upper velocity (see Annex G.2). The value is expressed in fractions of the Channel bit clock period as a number n such that

$$n = 16 \times \frac{T_C}{T_W} \quad \text{and} \quad 16 \leq n \leq 32$$

Byte 91 – dT_{le} write pulse leading edge shift for previous space =3T at Upper velocity

This byte shall specify the leading edge shift for the write pulse when the previous space was a 3T space for recording at Upper velocity (see Annex G.2). The value is expressed in fractions of the Channel bit clock period as a number n such that

$$n = 16 \times \frac{dT_{le}}{T_W} \quad \text{and} \quad 0 \leq n \leq 4$$

Byte 92 – dT_{le} write pulse leading edge shift for previous space =4T at Upper velocity

This byte shall specify the leading edge shift for the write pulse when the previous space was a 4T space for recording at Upper velocity (see Annex G.2). The value is expressed in fractions of the Channel bit clock period as a number n such that

$$n = 16 \times \frac{dT_{le}}{T_W} \quad \text{and} \quad 0 \leq n \leq 4$$

Byte 93 – dT_{le} write pulse leading edge shift for previous space =5T at Upper velocity

This byte shall specify the leading edge shift for the write pulse when the previous space was a 5T space for recording at Upper velocity (see Annex G.2). The value is expressed in fractions of the Channel bit clock period as a number n such that

$$n = 16 \times \frac{dT_{le}}{T_W} \quad \text{and} \quad 0 \leq n \leq 4$$

Bytes 94 - Reserved - All (00)

These bytes shall be set to all (00).

Byte 95 – P_{upper}/P_{lower} ratio

This byte shall specify the ratio of the optimized write power at the Upper recording velocity, $P_{wo_{Upper}}$, and the optimized write power at the Lower recording velocity speed, $P_{wo_{Lower}}$, where $P_{wo_{Upper}}$ and $P_{wo_{Lower}}$ shall be the write power level without emphasis determined at about the same diameter. The ratio is expressed as a number n such that

$$n = 200 \times \left(\frac{P_{wo_{Upper}}}{P_{wo_{Primary}}} - 1,5 \right)$$

Byte 96 - Extended Information block 1 Continuation bit / Format number

This byte shall be set to 1000 0100, indicating Format 4 and this block being a continuation block, for which bytes 97 to 127 have the following meaning:

Byte 97 - Reserved

This byte is reserved and shall be set to all (00).

Byte 98 - Maximum read power, P_r at Intermediate velocity

This byte shall specify the maximum read power P_r in milliwatts at Intermediate velocity as a number n such that

$$n = 20 \times (P_r - 0,7)$$

Byte 99 - P_{IND} at Intermediate velocity

P_{IND} is the starting value for the determination of P_{wo} used in the OPC algorithm, see Annex I and Annex K.

This byte shall specify the indicative value P_{IND} of P_{wo} in milliwatts at Intermediate velocity and λ_{IND} as a number n such that

$$n = 3 \times (P_{IND} - 5)$$

Byte 100 - β_{target} at Intermediate velocity

This byte shall specify the target value for β , β_{target} at Intermediate velocity used in the OPC algorithm (see Annex I) as a number n such that

$$n = 100 \times (\beta_{target} + 1)$$

Byte 101 - dPw power enhancement at Intermediate velocity

This byte shall specify the additional power for the 3T write pulse and for the beginning and end of all other write pulses (see Annex G.2) at Intermediate velocity as a number n such that

$$n = 200 \times \text{dPw} / \text{Pwo} \text{ and } 0 \leq n \leq 255$$

Byte 102 – T_{13} write pulse duration for 3T marks at Intermediate velocity

This byte shall specify the duration of the write pulse when the current mark is a 3T mark for recording at Intermediate velocity (see Annex G.2). The value is expressed in fractions of the Channel bit clock period as a number n such that

$$n = 16 \times \frac{T_{13}}{T_W} \text{ and } 16 \leq n \leq 48$$

Byte 103 – T_{top} duration of power enhancement at Intermediate velocity

This byte shall specify the duration of the power enhancement at the beginning of each write pulse when the current mark is a 4T or greater mark for recording at Intermediate velocity (see Annex G.2). The value is expressed in fractions of the Channel bit clock period as a number n such that

$$n = 16 \times \frac{T_{\text{top}}}{T_W} \text{ and } 4 \leq n \leq 32$$

Byte 104 – $T_{\text{end}} (\geq 5T)$ duration of power enhancement for $\text{cm} \geq 5T$ at Intermediate velocity

This byte shall specify the duration of the power enhancement at the end of each write pulse when the current mark is a 5T or greater mark for recording at Intermediate velocity (see Annex G.2). The value is expressed in fractions of the Channel bit clock period as a number n such that

$$n = 16 \times \frac{T_{\text{end}}}{T_W} \text{ and } 4 \leq n \leq 32$$

Byte 105 – $T_{\text{end}} (=4T)$ duration of power enhancement for $\text{cm} =4T$ at Intermediate velocity

This byte shall specify the duration of the power enhancement at the end of each write pulse when the current mark is a 4T mark for recording at Intermediate velocity (see Annex G.2). The value is expressed in fractions of the Channel bit clock period as a number n such that

$$n = 16 \times \frac{T_{\text{end}}}{T_W} \text{ and } 4 \leq n \leq 32$$

Byte 106 – T_C end of cooling gap at Intermediate velocity

This byte shall specify the end of the cooling gap for recording at Intermediate velocity (see Annex G.2). The value is expressed in fractions of the Channel bit clock period as a number n such that

$$n = 16 \times \frac{T_C}{T_W} \text{ and } 16 \leq n \leq 32$$

Byte 107 – dT_{le} write pulse leading edge shift for previous space =3T at Intermediate velocity

This byte shall specify the leading edge shift for the write pulse when the previous space was a 3T space for recording at Intermediate velocity (see Annex G.2). The value is expressed in fractions of the Channel bit clock period as a number n such that

$$n = 16 \times \frac{dT_{le}}{T_W} \quad \text{and} \quad 0 \leq n \leq 4$$

Byte 108 – dT_{le} write pulse leading edge shift for previous space =4T at Intermediate velocity

This byte shall specify the leading edge shift for the write pulse when the previous space was a 4T space for recording at Intermediate velocity (see Annex G.2). The value is expressed in fractions of the Channel bit clock period as a number n such that

$$n = 16 \times \frac{dT_{le}}{T_W} \quad \text{and} \quad 0 \leq n \leq 4$$

Byte 109 – dT_{le} write pulse leading edge shift for previous space =5T at Intermediate velocity

This byte shall specify the leading edge shift for the write pulse when the previous space was a 5T space for recording at Intermediate velocity (see Annex G.2). The value is expressed in fractions of the Channel bit clock period as a number n such that

$$n = 16 \times \frac{dT_{le}}{T_W} \quad \text{and} \quad 0 \leq n \leq 4$$

Byte 110 to 127 - Reserved - All (00)

These bytes shall be set to all (00).

Section 4 - Format of the Information Zone

15 General description of the Information Zone

The Information Zone, extending over two layers, shall contain all information on the disk relevant for data interchange. The Information Zone may contain one or more sessions (see clause 23). The Data Zones are intended for the recording of User Data.

The Lead-in Zone contains control information. The Lead-out Zone allows for a continuous smooth lead-out and also contains control information. The Middle Zones facilitate jumping from Layer 0 to Layer 1 at the end of the Data Zone on Layer 0.

The Inner and Outer Drive Areas are meant for disk testing.

In the next clauses 16 to 22 a description is given for a Single-session disk. In such a disk, the Lead-in Zone, the Data Zone, the Middle Zones and the Lead-out Zone constitute the recordable area in which the information is recorded using a non-reversible effect. The layout of a Multi-session disk is defined in clause 23.

16 Layout of the Information Zone of a Single-session disk

The Information Zone of single-sided and of each side of double-sided disks shall be sub-divided as shown in Table 7 and Table 8. The radii indicated in Table 7 and Table 8 for some of the Zones are the nominal values of the centre of the first or last track of the Zone.

Table 7 — Layout of a fully recorded Layer 0 on a Single-session disk (see also Annex A)

	Description	Nominal radius in mm	PSN of the first Physical Sector	Number of Physical Sectors
<u>Inner Drive Area</u>	Initial Zone	start 22,000 mm	--	blank
	Inner Disk Test Zone	start 22,659 mm	(024900)	16 384
	Count Zone Run-in	start 23,137 mm	(028900)	1 024
	Inner Disk Count Zone	start 23,166 mm	(028D00)	4 096
	Table of Contents Zone	start 23,284 mm	(029D00)	4 096
<u>Lead-in</u>	Guard Zone 1	start 23,400 mm	(02AD00)	12 672
	Reserved Zone 1		(02DE80)	4 096
	Reserved Zone 2		(02EE80)	64
	Inner Disk Identification Zone		(02EEC0)	256
	Reserved Zone 3		(02EFC0)	64
	Reference Code Zone		(02F000)	32
	Buffer Zone 1		(02F020)	480
	Control Data Zone		(02F200)	3 072
	Buffer Zone 2		(02FE00)	512
<u>Data</u>	Data Zone	start 24,000 mm	(030000)	2 086 912 max
<u>Middle Zone 0</u>	Buffer Zone 3	start 58,000 mm (at full capacity)	(22D800) max	768
	Reserved Zone		(22DB00) max	256
	Guard Zone 2		(22DC00) max	16 384 min
<u>Outer Drive Area</u>	Outer Disk Administration Zone	start 58,200 mm	(231C00)	4 096
	Outer Disk Count Zone	start 58,247 mm	(232C00)	4 096
	Dummy Zone	start 58,294 mm	(233C00)	1 024
	Outer Disk Test Zone	start 58,306 mm	(234000)	16 384
	Guard Zone 3	start 58,493 mm	(238000)	blank

Tracking direction ↓

Table 8 — Layout of a fully recorded Layer 1 on a Single-session disk (see also Annex A)

	Description	Nominal radius in mm	PSN of the first Physical Sector	Number of Physical Sectors
Inner Drive Area	Final Zone	end 22,000 mm	(FDB700)	blank
	Inner Disk Test Zone	end 22,659 mm	(FD7700)	16 384
	Dummy Zone	end 23,137 mm	(FD7300)	1 024
	Inner Disk Count Zone	end 23,166 mm	(FD6300)	4 096
	Inner Disk Administration Zone	end 23,284 mm	(FD5300)	4 096
Lead-out		end 23,400 mm	(FD0000)	21 248
	Data	Data Zone	end 24,000 mm (DD2800) min	2 086 912 max
Middle Zone 1	Buffer Zone 3	end 58,000 mm (at full capacity)	(DD2500) min	768
	Reserved Zone		(DD2400) min	256
	Guard Zone 2		(DCE400)	16 384 min
Outer Drive Area	Outer Disk Administration Zone	end 58,200 mm	(DCD400)	4 096
	Outer Disk Count Zone	end 58,247 mm	(DCC400)	4 096
	Count Zone Run-in	end 58,294 mm	(DCC000)	1 024
	Outer Disk Test Zone	end 58,306 mm	(DC8000)	16 384
	Guard Zone 3	end 58,493 mm	--	blank

Tracking direction ↑

16.1 Usage of the Data Zone

Depending on the application, it might be necessary to adapt the length of the Data Zone on Layer 0 (e.g. to set the “layer jump” at a predetermined position). In this case the start of Middle Zone 0 shall be shifted towards the inside of the disk. At the same time, the end of Middle Zone 1 shall be shifted by the same amount, such that the first address of the Data Zone on Layer 1 is the inverse of the last address of the Data Zone on Layer 0 (see 16.2). The layer jump is only allowed to be set at an ECC Block boundary. At the moment of setting, the layer jump shall be contained in the Incomplete Fragment (after the layer jump has been set, it is allowed to define a Reserved Fragment containing the layer jump; see clause 24).

The actual last PSN (end_L0) of the Data Zone on Layer 0 shall be recorded in all TOC Blocks (see 17.6.1) and shall be copied to the Control Data Zone (see 18.8.1) at closing of the first Session of a Multi-session disk or at finalization of a Single-session disk.

If at the moment of finalization not the full capacity of the disk has been used, the remainder of the Data Zone on Layer 1 is designated as Lead-out Zone.

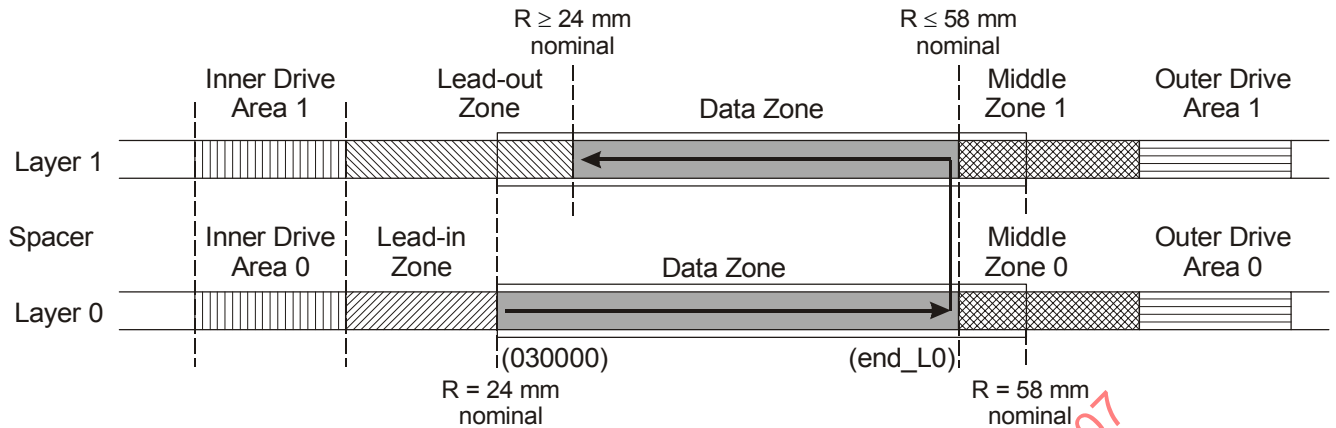

Figure 23 — Usage of the Data Zone

For the host/application the Data Zone on Layer 0 and the Data Zone on Layer 1 shall be treated as one contiguous Data Zone (see Figure 24 and clause 25). At the moment the ECC Block located at address (end_L0) in the Data Zone on Layer 1 has to be recorded, exactly 4 ECC Blocks in the Middle Zone 1 immediately preceding the Data Zone on Layer 1 shall be recorded. These 4 ECC Blocks function as a run-in for the Data Zone on Layer 1.

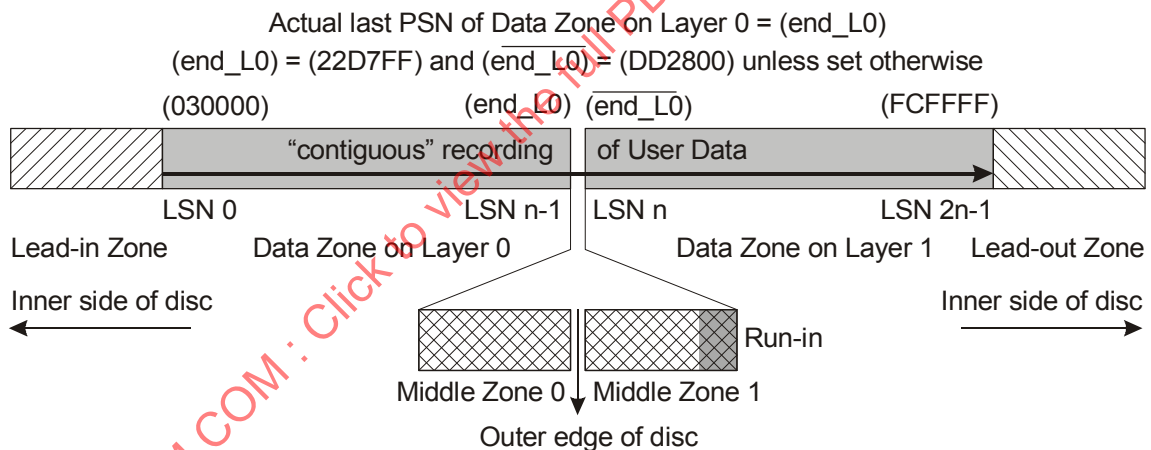

Figure 24 — Contiguity of Data Zones

16.1.1 Additional Testing Zone on Layer 1 (optional)

Drives for several reasons might prefer to do a power calibration on Layer 1 as close as possible to the start of the Data Zone on Layer 1. Therefore, in cases where the inner edge of the Middle Zones is moved inwards over a considerable distance, an additional OPC area consisting of a Count Zone, a Count Zone Run-in and a Test Zone may be created immediately connected to the Guard Zone 2 on Layer 1 (see Figure 25). Such an additional OPC area can only be created if the distance between the Guard Zone 2 (which in this case shall be exactly 16 384 Physical Sectors) and the Outer Drive Area 1 becomes larger than 1 344 EEC Blocks.

The choice for having the Additional Testing Zone shall be made at the moment the layer jump is set at a non-default location. The existence of the Additional Test Zone shall be indicated in the TOC Blocks (see 17.6.1, byte D₄₄).

The Additional Test Zone shall be used in the same way as the Outer Disk Test and Count Zone in the Outer Drive Area 1.

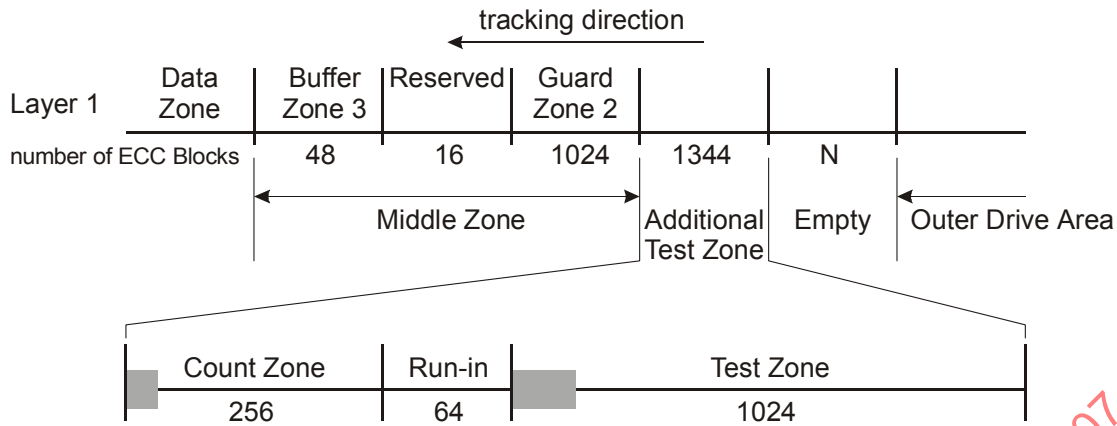

Figure 25 — Additional Testing Zone on Layer 1

If the layer jump (see 16.1) has been set before to an address < (070000), no Additional Testing Zone shall be applied.

16.2 Physical Sector Numbers (PSNs)

The PSNs on each recording layer increase by 1 for each next Physical Sector in the tracking direction on that layer (see Figure 26). The first Physical Sector of the Data Zone on Layer 0 shall have PSN (030000).

The Physical Sector Numbers on Layer 1 are derived from the Sector numbers at the same radial position on Layer 0 by inverting its bits, viz. changing from ZERO to ONE and vice versa. The highest Physical Sector Number in the Data Zone on Layer 0 (end_L0) shall be such that the inverted value is a multiple of 16.

NOTE The Physical Sector Number of the first Physical Sector of the Data Zone is large enough so as to prevent a Physical Sector Number ≤ 0 to occur anywhere on the disk.

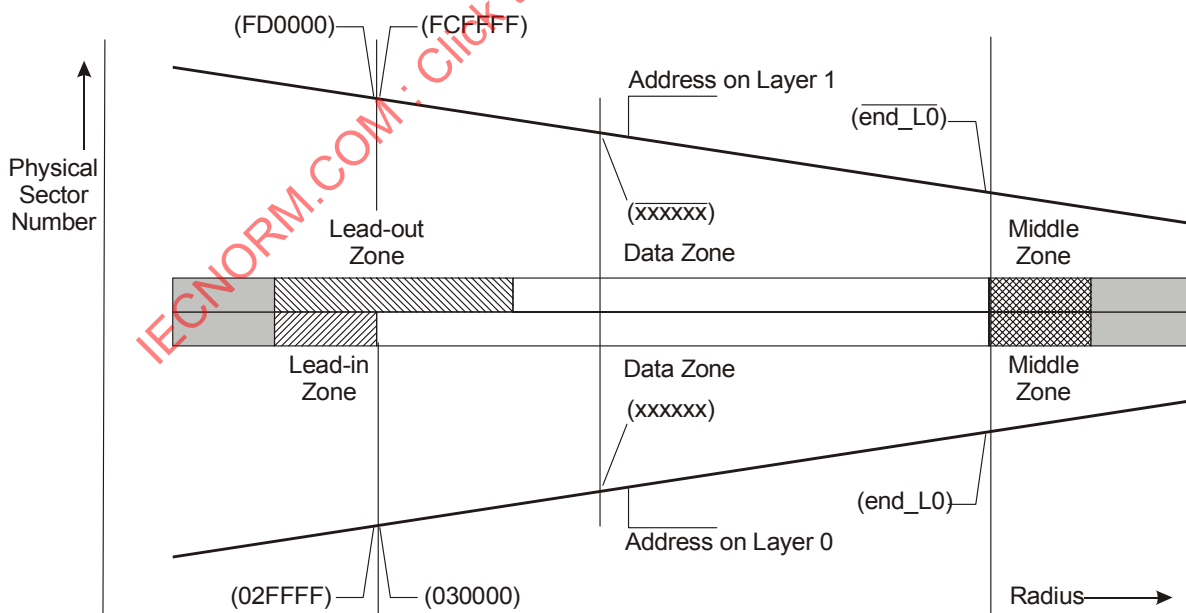

Figure 26 — Physical Sector numbering

17 Inner Drive Areas

Both layers have an Inner Drive Area. The Inner Drive Areas are located in the innermost zone of the disk and are used by the drive for performing disk tests and OPC algorithms. They shall consist of the parts shown in Figure 27 and Figure 28.

The Physical Sector Number of the first and last Physical Sector of each part is indicated in Figure 27 and Figure 28 in hexadecimal and decimal notation and the number of Physical Sectors in each part are indicated in decimal notation.

Unused ECC Blocks in the Inner Drive Area shall be left unrecorded (also at finalization of the disk).

	Initial Zone	
Physical Sector 149 759		Physical Sector (0248FF)
Physical Sector 149 760		Physical Sector (024900)
	Inner Disk Test Zone 16 384 Physical Sectors	
Physical Sector 166 143		Physical Sector (0288FF)
Physical Sector 166 144		Physical Sector (028900)
	Count Zone Run-in 1 024 Physical Sectors	
Physical Sector 167 167		Physical Sector (028CFF)
Physical Sector 167 168		Physical Sector (028D00)
	Inner Disk Count Zone 4 096 Physical Sectors	
Physical Sector 171 263		Physical Sector (029CFF)
Physical Sector 171 264		Physical Sector (029D00)
	Table of Contents Zone 4 096 Physical Sectors	
Physical Sector 175 359		Physical Sector (02ACFF)
Physical Sector 175 360		Physical Sector (02AD00)
	Lead-in Zone	

Figure 27 — Inner Drive Area on Layer 0

	Lead-out Zone	
Physical Sector 16 601 855		Physical Sector (FD52FF)
Physical Sector 16 601 856		Physical Sector (FD5300)
	Inner Disk Administration Zone 4 096 Physical Sectors	
Physical Sector 16 605 951		Physical Sector (FD62FF)
Physical Sector 16 605 952		Physical Sector (FD6300)
	Inner Disk Count Zone 4 096 Physical Sectors	
Physical Sector 16 610 047		Physical Sector (FD72FF)
Physical Sector 16 610 048		Physical Sector (FD7300)
	Dummy Zone 1 024 Physical Sectors	
Physical Sector 16 611 071		Physical Sector (FD76FF)
Physical Sector 16 611 072		Physical Sector (FD7700)
	Inner Disk Test Zone 16 384 Physical Sectors	
Physical Sector 16 627 455		Physical Sector (FDB6FF)
Physical Sector 16 627 456		Physical Sector (FDB700)
	Final Zone	

Figure 28 — Inner Drive Area on Layer 1

17.1 Initial Zone / Final Zone

These Zones shall remain blank.

17.2 Inner Disk Test Zones

16 384 Physical Sectors on each layer reserved for drive testing and OPC algorithms (see Annex I). The order in which these Physical Sectors shall be used is

- on Layer 0 from the outer side of the disk towards the inner side of the disk and
 - on Layer 1 from the inner side of the disk towards the outer side of the disk,
- so on both layers from the highest address towards the lowest address.

17.3 Count Zone Run-in / Dummy Zone

These areas with the size of 1 024 Physical Sectors each are meant as a Run-in / Buffer area between the Inner Disk Count Zone and the Inner Disk Test Zone and shall be left unrecorded.

17.4 Inner Disk Count Zones

4 096 Physical Sectors reserved for counting the number of OPC algorithms performed in the Inner Disk Test Zone (see Annex I). Each Disk Count Zone shall only comprehend the Disk Test Zone located on the same layer.

Whenever an ECC Block or part of it in the Inner Disk Test Zone has been recorded, the ECC Block shall be flagged by recording 4 Physical Sectors in the Inner Disk Count Zone. These 4 Physical Sectors shall be formatted according to the rules specified in 13.1 and the underlying subclauses, 13.2, 13.4, 13.5 and 13.6, whereby the Main Data bytes and the PI and PO bytes (see 13.3) can be chosen freely.

The relation between the first Physical Sector number PSN_{IDT} of the used ECC Block in the Inner Disk Test Zone and the Physical Sector numbers PSN_{IDC} to $PSN_{IDC} + 3$ of the 4 Physical Sectors in the Inner Disk Count Zone is determined by the following mathematical expressions:

$$PSN_{IDC} = \{(PSN_{IDT}) - (024900)\} / (04) + (028D00) \text{ for Layer 0, and}$$

$$PSN_{IDC} = \{(PSN_{IDT}) - (FD7700)\} / (04) + (FD6300) \text{ for Layer 1.}$$

17.5 Inner Disk Administration Zone

4 096 Physical Sectors to be used for optional drive specific information. The first 16 physical sectors of this Zone shall be filled with all Main Data set to (00).

Table 9 — General format of Disk Administration ECC Blocks

Physical Sector of each Adm. Block	Main Data BP	Description
0	D ₀ to D ₃	Content Descriptor
0	D ₄ to D ₇	Reserved and set to (00)
0	D ₈ to D ₃₉	Drive ID
0	D ₄₀ to D ₆₃	Reserved and set to (00)
0	D ₆₄ to D _{2 047}	Drive Specific
1 to 15	D ₀ - D _{2 047}	Drive Specific

Physical Sector 0 / bytes D₀ to D₃ – Content Descriptor

These bytes identify the Administration Block and shall be set to (41444D00), representing the characters “ADM” and the version number 0.

Physical Sector 0 / bytes D₄ to D₇ – Reserved

These bytes are reserved and shall be set to (00)

Physical Sector 0 / bytes D₈ to D₃₉ – Drive ID

These bytes shall contain the drive ID as specified in 26.1, bytes D₈ to D₃₉.

Physical Sector 0 / bytes D₄₀ to D₆₃ – Reserved

These bytes are reserved and shall be set to (00).

Physical Sector 0 / bytes D₆₄ to D_{2 047} – Drive Specific

These bytes may be used to store Drive Specific information. The format is not defined and can be freely chosen by the drive manufacturer.

Physical Sectors 1 to 15 / bytes D₀ to D_{2 047} – Drive Specific

These bytes may be used to store Drive Specific information. The format is not defined and can be freely chosen by the drive manufacturer.

17.6 Table of Contents (TOC) Zone

4 096 Physical Sectors to store information about the locations of Sessions and recordings on the disk. The first 16 physical sectors of this Zone shall be filled with all Main Data set to (00).

This Zone consists of 3 parts:

- part 1: consists of 127 ECC Blocks (TOC Blocks) to be used to store the locations of all Closed Sessions,
- part 2: consists of 1 024 Physical Sectors, grouped in units of 4 sectors, where each unit corresponds to one ADIP word. These units shall be used as Recorded Area Indicators for Layer 1,
- part 3: consists of 1 024 Physical Sectors, grouped in units of 4 sectors, where each unit corresponds to one ADIP word. These units shall be used as Recorded Area Indicators for Layer 0.

17.6.1 Table of Contents Blocks

Whenever the host/application sends a request to set the layer jump position or whenever a Session is closed, the next ECC Block in the Table of Contents Zone, immediately following the last TOC Block, shall be recorded with the locations of all Closed Sessions. The first ECC Block in the Table of Contents Zone has to be used as a run-in for the second ECC Block. If all 127 TOC Blocks have been used, no additional Sessions shall be added (see also 24.2 and 24.3).

The format of the TOC Blocks shall be as defined in Table 10.

Table 10 — Format of the TOC Blocks

Physical Sector of TOC block	Main Data byte position	Description	number of bytes
0	D ₀ to D ₃	Content Descriptor	4
0	D ₄ to D ₇	Reserved and set to (00)	4
0	D ₈ to D ₃₉	Drive ID	32
	D ₄₀	Reserved and set to (00)	1
0	D ₄₁ to D ₄₃	Actual last PSN of Data Zone	3
0	D ₄₄	Flag bits	1
0	D ₄₅ to D ₄₇	Actual last PSN of Data Zone on Layer 0	3
0	D ₄₈ to D ₆₃	Reserved and set to (00)	16
0	D ₆₄ to D ₇₉	TOC Item 0	16
0	...		
0	D _{64+i×16} to D _{79+i×16}	TOC Item i	16
0	
0	D _{64+(N-1)×16} to D _{79+(N-1)×16}	TOC Item N-1	16
0	D _{64+N×16} to D _{2 047}	Reserved and set to (00)	1 984 - N×16
1 to 3	D ₀ to D _{2 047}	Extension for TOC Items or Reserved and set to (00)	3×2 048
4 to 7	D ₀ to D _{2 047}	Repetition of Sectors 0 to 3 (recommended) or Reserved and set to (00)	4×2 048
8 to 11	D ₀ to D _{2 047}	Repetition of Sectors 0 to 3 (recommended) or Reserved and set to (00)	4×2 048
12 to 15	D ₀ to D _{2 047}	Repetition of Sectors 0 to 3 (recommended) or Reserved and set to (00)	4×2 048

Physical Sector 0 / bytes D₀ to D₃ – Content Descriptor

These bytes identify the TOC Block and shall be set to (544F4300), representing the characters “TOC” and the version number 0.

Physical Sector 0 / bytes D₄ to D₇ – Reserved

These bytes are reserved and shall be set to (00).

Physical Sector 0 / bytes D₈ to D₃₉ – Drive ID

These bytes shall contain the drive ID as specified in 26.1, bytes D₈ to D₃₉.

Physical Sector 0 / byte D₄₀ – Reserved

This byte is reserved and shall be set to (00).

Physical Sector 0 / bytes D₄₁ to D₄₃ – Actual last PSN of Data Zone

These 3 bytes shall specify the PSN of the last Physical Sector in the Data Zone.

Initially this field shall be set to (FCFFFF).

After closing the first Session this field shall be set to (FCFFFF) or (F8FFFF) according to the length of the Partial Lead-out (see 26.2).

After finalization of the disk this field shall be set to the real last PSN of the Data Zone (can also be on Layer 0 if Layer 1 does not contain any user data).

Physical Sector 0 / byte D₄₄ – Flag bits

Bits b₇ to b₁ Reserved
 These bits shall be set to all ZERO.

Bit b₀ **Additional Test Zone on Layer 1**
 if set to ONE, an Additional Test Zone on Layer 1 is present,
 is set to ZERO, no Additional Test Zone on Layer 1 is present.

Physical Sector 0 / bytes D₄₅ to D₄₇ – Actual last PSN of Data Zone on Layer 0 (end_L0)

These 3 bytes shall specify the PSN of the last Physical Sector in the Data Zone on Layer 0. If not requested differently by the host/application, this address shall be set to (22D7FF) (see 16.1 and also Annex A).

The host/application can request to set this field to a specific value (setting the layer jump at some specific position), as long as the first Session on the disk has not been closed. In such case the drive shall create a (first) TOC Block including this requested value which shall be \leq (22D7FF), but without any TOC Item included.

Once the value of this field has been set, it shall not be changed until finalization of the disk and it shall be copied to all TOC Blocks recorded at later occasions.

At finalization of the disk the value of this field shall be kept unchanged if it is less than the Actual last PSN of Data Zone (the actual user recordings extend beyond the layer jump onto Layer 1); else this field shall be set to the same value as the Actual last PSN of Data Zone (see also Figure 37 and Figure 38).

Physical Sector 0 / bytes D₄₈ to D₆₃ – Reserved

These bytes are reserved and shall be set to (00).

Physical Sector 0 / bytes D₆₄ to D_{2 047} – TOC Items

These bytes are grouped in units of 16 bytes each. Each unit of 16 bytes may contain a TOC Item according to the format defined in 17.6.1.1. All bytes not containing TOC Items shall be set to (00).

Physical Sectors 1 to 3 / bytes D₀ to D_{2 047} – Extension for TOC Items or Reserved

These bytes may hold additional TOC Items. All bytes not containing TOC Items shall be set to (00).

Physical Sectors 4 to 15 / bytes D₀ to D_{2 047} – Repetitions of Sectors 0 to 3 or all Reserved

For robustness reasons it is recommended to repeat the content of Sectors 0 to 3 in Sectors 4 to 7, in Sectors 8 to 11 and in Sectors 12 to 15.

If this option is not used, these bytes shall be set to (00).

It is a matter of drive implementation to recognize and make use of the repetitions.

17.6.1.1 TOC Items

Item byte position	Description	number of bytes
B ₀ to B ₂	TOC Item descriptor	3
B ₃	Session Status	1
B ₄	Session number	1
B ₅ to B ₇	Session start address	3
B ₈ to B ₁₀	Session end address	3
B ₁₁ to B ₁₂	Last Fragment number in Session	2
B ₁₃ to B ₁₅	Reserved and set to (00)	3

The TOC Block shall contain a TOC Item for each Closed Session on the disk. The TOC Items shall be ordered with increasing numbers and addresses.

TOC Item bytes B₀ to B₂ – TOC Item descriptor

These 3 bytes identify the item type and shall be set to (544349), representing the characters "TCI".

TOC Item byte B₃ – Session Status

This byte shall indicate the Status of the last Session. It shall be set to (00) in all TOC Items, except in the TOC Item describing the last Session on the disk.

If set to (00) in the last TOC Item, adding a new Session to the disk is allowed.

If set to (01) in the last TOC Item, the last Session shall be the final Session on the disk. The disk has been Fully Finalized (see clause 22) and adding new Sessions is not allowed (see 24.3).

TOC Item byte B₄ – Session number

This byte shall specify the sequence number of the Session specified in this item.

TOC Item bytes B₅ to B₇ – Session start address

These 3 bytes shall specify the PSN of the first Physical Sector in the Data Zone of the Session specified in this item.

TOC Item bytes B₈ to B₁₀ – Session end address

These 3 bytes shall specify the PSN of the last Physical Sector in the Data Zone of the Session specified in this item.

TOC Item bytes B₁₁ to B₁₂ – Last Fragment number in Session

These 2 bytes specify the sequence number of the last Fragment in the Session specified in this item.

If this option is not used, these bytes shall be set to (00).

TOC Item bytes B₁₃ to B₁₅ – Reserved

These 3 bytes are reserved and shall be set to (00).

17.6.2 Recorded Area Indicators

To speed up the access of the disk, the recorder needs to know in which region of the disk the last written ECC Block can be found. For this purpose a kind of “bitmap” is defined, based on recorded areas with the size of 4 Physical Sectors, each area corresponding to one ADIP word. The 4 Physical Sectors shall be formatted according to the rules specified in 13.1 and the underlying subclauses, 13.2, 13.4, 13.5 and 13.6, whereby the Main Data bytes and the PI and PO bytes (see 13.3) can be chosen freely.

2 times 1 024 Physical Sectors have been reserved for this “bitmap” purpose (each set of 1 024 for one layer), allowing to divide each layer of the disk into maximum 256 regions. The Recorded Area Indicators shall be used from the outer side of the TOC Zone towards the inner side of the TOC Zone (see Figure 29). By means of an “HF-detection” the recorder can find the locations of the Recorded Area Indicators and determine the regions which contain recorded ECC Blocks.

Whenever the disk is ejected from the drive, the Recorded Area Indicators shall reflect the actual status of the recordings on the disk.

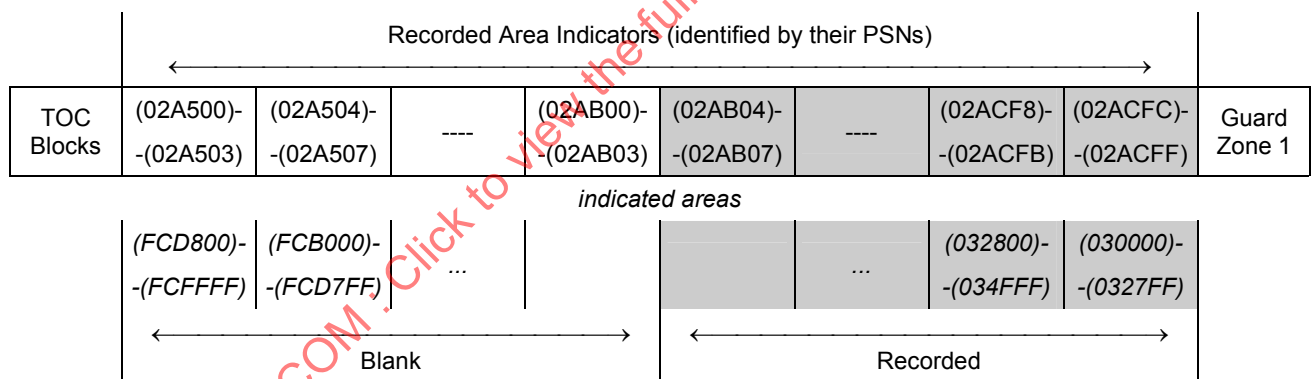

Figure 29 — Use of Recorded Area Indicators

17.6.2.1 Recorded Area Indicators for Layer 0

Each region of 640 ECC Blocks between PSN = (030000) and PSN = (22D7FF) (theoretical limit = (2AFFFF)) corresponds to one Recorded Area Indicator. All regions that contain one or more recorded ECC Blocks shall be indicated by their Recorded Area Indicator.

In mathematical form:

if the Recorded Area Indicator composed of the Physical Sectors with PSN_{RAI} to PSN_{RAI} + 3 has been recorded, than the region between:

$$PSN = \{(02ACFC)-(PSN_{RAI})\} \times (A00) + (030000) \text{ and}$$

$$PSN = \{(02ACFC)-(PSN_{RAI})\} \times (A00) + (0327FF)$$

contains recorded ECC Blocks,

or in decimal notation:

$$\text{PSN} = \{175\ 356 - \text{PSN}_{\text{RAI}}\} \times 2\ 560 + 196\ 608 \text{ and}$$

$$\text{PSN} = \{175\ 356 - \text{PSN}_{\text{RAI}}\} \times 2\ 560 + 206\ 847.$$

17.6.2.2 Recorded Area Indicators for Layer 1

Each region of 640 ECC Blocks between PSN = (DD2800) (theoretical limit = (D50000)) and PSN = (FCFFFF) corresponds to one Recorded Area Indicator. All regions that contain one or more recorded ECC Blocks shall be indicated by their Recorded Area Indicator.

In mathematical form:

if the Recorded Area Indicator composed of the Physical Sectors with PSN_{RAI} to PSN_{RAI} + 3 has been recorded, then the region between:

$$\text{PSN} = \{(02A8FC) - (\text{PSN}_{\text{RAI}})\} \times (A00) + (D50000) \text{ and}$$

$$\text{PSN} = \{(02A8FC) - (\text{PSN}_{\text{RAI}})\} \times (A00) + (D527FF)$$

contains recorded ECC Blocks,

or in decimal notation:

$$\text{PSN} = \{174\ 332 - \text{PSN}_{\text{RAI}}\} \times 2\ 560 + 13\ 959\ 168 \text{ and}$$

$$\text{PSN} = \{174\ 332 - \text{PSN}_{\text{RAI}}\} \times 2\ 560 + 13\ 969\ 407.$$

18 Lead-in Zone

The Lead-in Zone is located on Layer 0 at the inner side of the Information Zone. It shall consist of the parts shown in Figure 30.

The Physical Sector Number of the first and last Physical Sector of each part is indicated in Figure 30 in hexadecimal and decimal notation and the number of Physical Sectors in each part are indicated in decimal notation.

A maiden disk does not have any data recorded in the Lead-in Zone. After finalization of the disk or closing of the first Session, the Lead-in Zone shall be recorded according to 18.1 to 18.9.

Physical Sector 175 359	Inner Drive Area	Physical Sector (02ACFF)
Physical Sector 175 360		Physical Sector (02AD00)
Physical Sector 188 031	Guard Zone 1 12 672 Physical Sectors with Main Data set to (00)	Physical Sector (02DE7F)
Physical Sector 188 032		Physical Sector (02DE80)
Physical Sector 192 127	Reserved Zone 1 4 096 Physical Sectors	Physical Sector (02EE7F)
Physical Sector 192 128		Physical Sector (02EE80)
Physical Sector 192 191	Reserved Zone 2 64 Physical Sectors	Physical Sector (02EEBF)
Physical Sector 192 192		Physical Sector (02EEC0)
Physical Sector 192 447	Inner Disk Identification Zone 256 Physical Sectors	Physical Sector (02EFBF)
Physical Sector 192 448		Physical Sector (02EFC0)
Physical Sector 192 511	Reserved Zone 3 64 Physical Sectors	Physical Sector (02EFFF)
Physical Sector 192 512		Physical Sector (02F000)
Physical Sector 192 543	Reference Code Zone 32 Physical Sectors	Physical Sector (02F01F)
Physical Sector 192 544		Physical Sector (02F020)
Physical Sector 193 023	Buffer Zone 1 480 Physical Sectors with Main Data set to (00)	Physical Sector (02F1FF)
Physical Sector 193 024		Physical Sector (02F200)
Physical Sector 196 095	Control Data Zone 3 072 Physical Sectors	Physical Sector (02FDFF)
Physical Sector 196 096		Physical Sector (02FE00)
Physical Sector 196 607	Buffer Zone 2 512 Physical Sectors	Physical Sector (02FFFF)
Physical Sector 196 608		Physical Sector (030000)
	Data Zone	

Figure 30 — Lead-in Zone

18.1 Guard Zone 1

This Guard Zone is used to create a minimum amount of Lead-in Zone required for compatibility. This zone shall contain 12 672 Physical Sectors, all filled with Main Data set to (00).

18.2 Reserved Zone 1

4 096 Physical Sectors are reserved and shall be set to (00).

18.3 Reserved Zone 2

64 Physical Sectors are reserved and shall be set to (00).

18.4 Inner Disk Identification Zone

256 Physical Sectors reserved for information agreed upon by the data interchange parties. Each set of 16 Physical Sectors from one ECC Block is either a Disk Control Block (DCB) (see clause 26) or recorded with all (00) Main Data. Each ECC Block in this Zone following one recorded with all (00) Main Data shall also be recorded with all (00) Main Data.

18.5 Reserved Zone 3

64 Physical Sectors are reserved and shall be set to (00).

18.6 Reference Code Zone

The recorded Reference Code Zone shall consist of the 32 Physical Sectors from two ECC Blocks which generate a specific Channel bit pattern on the disk. This shall be achieved by setting to (AC) all 2 048 Main Data bytes of each corresponding Data Frame. Moreover, no scrambling shall be applied to these Data Frames, except to the first 160 Main Data bytes of the first Data Frame of each ECC Block.

18.7 Buffer Zone 1

This Zone shall consist of 480 Physical Sectors from 30 ECC Blocks. The Main Data of the Data Frames in this Zone shall be set to all (00).

18.8 Control Data Zone

This Zone shall consist of 3 072 Physical Sectors from 192 ECC Blocks. The content of the 16 Physical Sectors of each ECC Block is repeated 192 times. The structure of a Control Data Block shall be as shown in Figure 31.

Physical format information 2 048 bytes
Disk manufacturing information 2 048 bytes
Content provider information 14 × 2 048 bytes

Figure 31 — Structure of a Control Data Block

18.8.1 Physical format information

This information shall comprise the 2 048 bytes shown in Table 11. It contains disk and format information.

Table 11 — Physical format information

Byte number	Content	Number of bytes
0	Disk Category and Version Number	1
1	Disk size	1
2	Disk structure	1
3	Recording density	1
4 to 15	Data Zone allocation	12
16	General Flag bits	1
17	Disk Application Code	1
18	Extended Information indicators	1
19 to 26	Disk Manufacturer ID	8
27 to 29	Media Type ID	3
30	Product revision number	1
31	number of Physical format information bytes in use in ADIP up to byte 63	1
32 to 63	Basic write strategy parameters for Layer 0	32
64 to 95	Extended Information block 0 for Layer 0	32
96 to 127	Extended Information block 1 for Layer 0	32
128 to 159	Extended Information block 2 for Layer 0	32
160 to 191	Extended Information block 3 for Layer 0	32
192 to 223	Extended Information block 4 for Layer 0	32
224 to 247	Extended Information block 5 for Layer 0	24
248 to 251	Start of Session	4
252 to 255	End of Session	4
256	Disk Category and Version Number	1
257	Disk size	1
258	Disk structure	1
259	Recording density	1
260 to 271	Data Zone allocation	12
272	Set to (00)	1
273	Disk Application Code	1
274	Extended Information indicators	1
275 to 282	Disk Manufacturer ID	8
283 to 285	Media Type ID	3
286	Product revision number	1
287	number of Physical format information bytes in use in ADIP up to byte 63	1
288 to 319	Basic write strategy parameters for Layer 1	32
320 to 351	Extended Information block 0 for Layer 1	32
352 to 383	Extended Information block 1 for Layer 1	32
384 to 415	Extended Information block 2 for Layer 1	32
416 to 447	Extended Information block 3 for Layer 1	32
448 to 479	Extended Information block 4 for Layer 1	32
480 to 503	Extended Information block 5 for Layer 1	24
504 to 507	Reserved – All (00)	4
508 to 511	Reserved – All (00)	4
512 to 2 047	Reserved – All (00)	1 536

The information in bytes 0 to 255 have the same definitions and shall have the same contents as bytes 0 to 255 of the Physical format information in the ADIP Aux Frames on Layer 0 as defined in Table 3 and 14.4.2, except the following bytes:

Byte 1 - Disk size and maximum transfer rate

Bits b₇ to b₄ same as 14.4.2

Bits b₃ to b₀ shall specify the maximum read transfer rate.

These bits may be set to one of the following values (depending on the maximum read-out speed needed by the application):

0000: specify a maximum transfer rate of 2,52 Mbits/s (See note at 31.3)

0001: specify a maximum transfer rate of 5,04 Mbits/s (See note at 31.3)

0010: specify a maximum transfer rate of 10,08 Mbits/s

1111: specify no maximum transfer rate is specified.

All other combinations are reserved and shall not be used.

Bytes 4 to 15 - Data Zone allocation

Bytes 4 to 8 same as 14.4.2

Bytes 9 to 11 on a finalized Single-session disk (see 24.3):
shall specify the Sector Number of the last Physical Sector of the Data Zone.

on a Multi-session disk (see clause 23):

shall be set to (FCFFFF) or (F8FFFF) to specify PSN 16 580 607 or 16 318 463 (see clause 22, 24.2 and 24.3) as the last possible Physical Sector on the disk for the storage of User Data.

Bytes 12 same as 14.4.2

Bytes 13 to 15 shall specify the Sector Number of the actual last Physical Sector of the Data Zone on Layer 0. These 3 bytes shall be equal to bytes D₄₅ to D₄₇ of Sector 0 of the TOC Blocks (see 17.6.1) in the Table of Contents Zone.

Byte 16 – General Flag bits

Bit b₇ same as 14.4.2

Bit b₆ same as 14.4.2

Bit b₅ shall specify if Buffer Zone 2 in the Lead-in Zone contains VCPS related information,
shall be set to 0, indicating no VCPS related information is present in Buffer Zone 2,
shall be set to 1, indicating Buffer Zone 2 contains VCPS related information as defined in the VCPS System Description (see Annex P).

Bits b₄ to b₀ same as 14.4.2

NOTE When closing the first Session, drives not designed to handle VCPS might set bit b₅ = 0 even when Buffer Zone 2 contains VCPS related information (recorded before by some other drive).

Bytes 248 to 251 – Start of first Session

Byte 248 shall be set to (00).

Bytes 249 to 251 shall be set to (030000) to specify PSN 196 608 of the first Physical Sector of the Data Zone of the first Session (see clause 23).

Bytes 252 to 255 – End of first Session

Byte 252 shall be set to (00).

Bytes 253 to 255 shall specify the Sector Number of the last Physical Sector of the Data Zone of the first Session (see clause 23).

The information in **bytes 256 to 511** have the same definitions and shall have the same contents as bytes 0 to 255 of the Physical format information in the ADIP Aux Frames on Layer 1 as defined in Table 3 and 14.4.2.

The remaining **bytes 512 to 2047** have no relation to the ADIP information and shall be set to all (00).

18.8.2 Disk manufacturing information

This Standard does not specify the format and the content of these 2 048 bytes. They shall be ignored in interchange.

18.8.3 Content provider information

These 28 672 bytes shall be set to all (00).

Under no circumstance may data received from the host be recorded in this field.

***Circumvention:** Recorders and recording drives shall be considered as circumvention devices when these are produced to record, or can easily be modified to record, in any manner, a user-defined number in this field.*

18.9 Buffer Zone 2

This recorded Zone shall consist of 512 Physical Sectors from 32 ECC Blocks. During use of the disk VCPS related information may be recorded to these 32 ECC Blocks, according to the specifications given in the VCPS System Description (see Annex P). Such VCPS related information shall only be recorded when requested by the host/application.

If no VCPS related information is copied to these locations then the Main Data of the Data Frames in this Zone shall be set to all (00).

Whenever Buffer Zone 2 has been recorded, also the first ECC Block of the Data Zone shall be recorded.

19 Data Zone

Two times 2 086 912 Physical Sectors for the storage of user data (see also Annex A).

The start radius of the Data Zone on Layer 0 and Layer 1 is determined by the location of Physical ADIP Address (00C000) and (F74A00) respectively and the maximum/minimum end radius is determined by the location of Physical ADIP Address (08B600) and (FF4000) respectively (see 14.4.1.1, bit 2 to 23 and 13.7.1).

20 Middle Zones

Both layers have a Middle Zone located at the outer side of the disk. They shall consist of the parts specified in Figure 32 and Figure 33. The Physical Sector Number of the first and the last Physical Sector of each part is indicated in Figure 32 and Figure 33 in hexadecimal and decimal notation and the number of Physical Sectors in each part is indicated in decimal notation. (see also Annex A)

Normally the Middle Zones shall be located opposite each other, meaning that the end address of the Middle Zone on Layer 1 (the most inner PSN) is the inverse of the start address of the Middle Zone on Layer 0 (also the most inner PSN). However in the case of an extended Partial Lead-out Zone (see 22.2) and the start of

the Middle Zone on Layer 0 located at an address < (070000), the Middle Zones shall be recorded immediately following the last recorded data on Layer 0, respectively immediately preceding the extended Partial Lead-out on Layer 1.

Physical Sector 2 283 519 max	Data Zone on Layer 0	Physical Sector (22D7FF) max
Physical Sector 2 283 520 max	Buffer Zone 3 768 Physical Sectors with Main Data set to (00)	Physical Sector (22D800) max
Physical Sector 2 284 287 max	Reserved 256 Physical Sectors	Physical Sector (22DAFF) max
Physical Sector 2 284 288 max		Physical Sector (22DB00) max
Physical Sector 2 284 543 max	Guard Zone 2 min 16 384 Physical Sectors with Main Data set to (00) (remaining sectors are allowed to be unrecorded)	Physical Sector (22DBFF) max
Physical Sector 2 284 544 max		Physical Sector (22DC00) max
Physical Sector 2 300 927	Outer Drive Area	Physical Sector (231BFF)
Physical Sector 2 300 928		Physical Sector (231C00)

Figure 32 — Middle Zone on Layer 0

Physical Sector 14 476 287	Outer Drive Area	Physical Sector (DCE3FF)
Physical Sector 14 476 288	Guard Zone 2 min 16 384 Physical Sectors with Main Data set to (00) (remaining sectors are allowed to be unrecorded)	Physical Sector (DCE400)
Physical Sector 14 492 671 min		Physical Sector (DD23FF) min
Physical Sector 14 492 672 min	Reserved Zone 256 Physical Sectors	Physical Sector (DD2400) min
Physical Sector 14 492 927 min		Physical Sector (DD24FF) min
Physical Sector 14 492 928 min	Buffer Zone 3 768 Physical Sectors with Main Data set to (00)	Physical Sector (DD2500) min
Physical Sector 14 493 695 min		Physical Sector (DD27FF) min
Physical Sector 14 493 696 min	Data Zone on Layer 1	Physical Sector (DD2800) min

Figure 33 — Middle Zone on Layer 1

The Middle Zones shall be recorded completely when the Session that passes the layer jump position is closed (end address of Closure > (end_L0), see Figure 34) or when the disk is finalized, whichever of the two happens first.

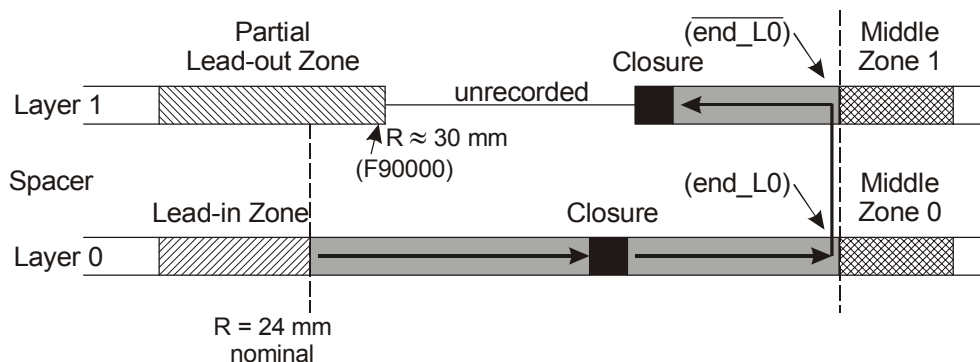

Figure 34 — Example of closing a Session crossing the layer jump

20.1 Buffer Zones 3

These recorded Zones shall consist of 768 Physical Sectors. The outermost possible start location of Buffer Zone 3 is (22D800) on Layer 0 and (DD2500) on Layer 1 (see also Annex A). The Main Data of the Data Frames in this Zone shall be set to all (00).

20.2 Reserved Zones

256 Physical Sectors are reserved and shall be set to (00).

20.3 Guard Zones 2

These Guard Zones are used as a protection for separating test writing zones from information zones containing user data. They also provide for a recorded area on the opposite layer, at any position within the Data Zone of each layer (to cope with radial misalignments of inner and outer diameters of the Data Zones).

These zones shall contain a minimum of 16 384 Physical Sectors filled with Main Data set to (00), adjoining the Reserved Zone (see also Annex A).

If the total storage capacity of the disk is not fully used, the Guard Zone 2 can be extended with Physical Sectors filled with Main Data set to (00) to fill up the gap up to a certain radius or up to the Outer Drive Area, or this gap can be left unrecorded. The choice for these options is left to the drive manufacturer.

21 Outer Drive Areas

Both layers have an Outer Drive Area. The Outer Drive Areas are located in the outermost zone of the disk and are used by the drive for performing disk tests and OPC algorithms. They shall consist of the parts shown in Figure 35 and Figure 36.

The Physical Sector Number of the first and last Physical Sector of each part is indicated in Figure 35 and Figure 36 in hexadecimal and decimal notation and the number of Physical Sectors in each part are indicated in decimal notation. (see also Annex A)

Unused ECC Blocks in the Outer Drive Area shall be left unrecorded (also at finalization of the disk).

21.1 Outer Disk Administration Zones

Two times 4 096 Physical Sectors to be used for optional drive specific information. The first 16 physical sectors of these Zones shall be filled with all Main Data set to (00). These zones can be used in the same way as the Inner Disk Administration Zone (see 17.5).

Physical Sector 2 300 927	Middle Zone	Physical Sector (231BFF)
Physical Sector 2 300 928	Outer Disk Administration Zone 4 096 Physical Sectors	Physical Sector (231C00)
Physical Sector 2 305 023		Physical Sector (232BFF)
Physical Sector 2 305 024	Outer Disk Count Zone 4 096 Physical Sectors	Physical Sector (232C00)
Physical Sector 2 309 119		Physical Sector (233BFF)
Physical Sector 2 309 120	Dummy Zone 1 024 Physical Sectors	Physical Sector (233C00)
Physical Sector 2 310 143	Outer Disk Test Zone 16 384 Physical Sectors	Physical Sector (233FFF)
Physical Sector 2 310 144		Physical Sector (234000)
Physical Sector 2 326 527	Guard Zone 3 Blank	Physical Sector (237FFF)
Physical Sector 2 326 528		Physical Sector (238000)

Figure 35 — Outer Drive Area on Layer 0

Physical Sector 14 450 687	Guard Zone 3 Blank	Physical Sector (DC7F FF)
Physical Sector 14 450 688	Outer Disk Test Zone 16 384 Physical Sectors	Physical Sector (DC8000)
Physical Sector 14 467 071		Physical Sector (DCBFFF)
Physical Sector 14 467 072	Count Zone Run-in 1 024 Physical Sectors	Physical Sector (DCC000)
Physical Sector 14 468 095		Physical Sector (DCC3FF)
Physical Sector 14 468 096	Outer Disk Count Zone 4 096 Physical Sectors	Physical Sector (DCC400)
Physical Sector 14 472 191		Physical Sector (DCD3FF)
Physical Sector 14 472 192	Outer Disk Administration Zone 4 096 Physical Sectors	Physical Sector (DCD400)
Physical Sector 14 476 287		Physical Sector (DCE3FF)
Physical Sector 14 476 288	Middle Zone	Physical Sector (DCE400)

Figure 36 — Outer Drive Area on Layer 1

21.2 Outer Disk Count Zones

4 096 Physical Sectors (see also Annex A) reserved for counting the number of OPC algorithms performed in the Outer Disk Test Zone (see Annex I). Each Disk Count Zone shall only comprehend the Disk Test Zone located on the same layer.

Whenever an ECC Block or part of it in the Outer Disk Test Zone has been recorded, the ECC Block shall be flagged by recording 4 Physical Sectors in the Outer Disk Count Zone. These 4 Physical Sectors shall be formatted according to the rules specified in 13.1 and the underlying subclauses, 13.2, 13.4, 13.5 and 13.6, whereby the Main Data bytes and the PI and PO bytes (see 13.3) can be chosen freely.

The relation between the first Physical Sector number PSN_{ODT} of the used ECC Block in the Outer Disk Test Zone and the Physical Sector numbers PSN_{ODC} to $PSN_{ODC} + 3$ of the 4 Physical Sectors in the Outer Disk Count Zone is determined by the following mathematical expressions (see also Annex A):

$$PSN_{ODC} = \{(PSN_{ODT}) - (234000)\} / (04) + (232C00) \text{ for Layer 0, and}$$

$$PSN_{ODC} = \{(PSN_{ODT}) - (DC8000)\} / (04) + (DCC400) \text{ for Layer 1.}$$

21.3 Dummy Zone / Count Zone Run-in

These areas with the size of 1 024 Physical Sectors each are meant as a Run-in / Buffer area between the Inner Disk Count Zone and the Inner Disk Test Zone and shall be left unrecorded.

21.4 Outer Disk Test Zone

16 384 Physical Sectors (see also Annex A) on each layer reserved for drive testing and OPC algorithms (see Annex I). The order in which these Physical Sectors shall be used is

- on Layer 0 from the outer side of the disk towards the inner side of the disk and
 - on Layer 1 from the inner side of the disk towards the outer side of the disk,
- so on both layers from the highest address towards the lowest address.

21.5 Guard Zones 3

These Zones shall remain blank.

22 Lead-out Zone

The Lead-out Zone is located at the inner side of the disk on Layer 1. The minimum length of the Lead-out Zone is 21 248 sectors, ranging from address (FD0000) at radius 24,0 mm nominal to address (FD5300) at radius 23,4 mm nominal, all recorded with Main Data set to (00).

22.1 Lead-out Zone at finalization

At finalization (see 24.3) all remaining blank area of the Data Zone shall be recorded as additional Lead-out Zone.

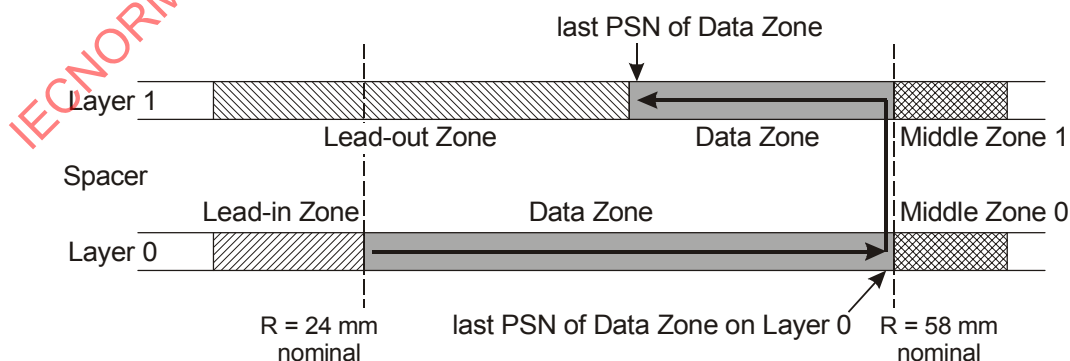

Figure 37 — Example of Finalized disk

If a disk only containing data on Layer 0 has to be finalized, then the Middle Zones shall be recorded at a position immediately adjoining the end of the user data on Layer 0. All remainder of Layer 1 shall be recorded as Lead-out Zone.

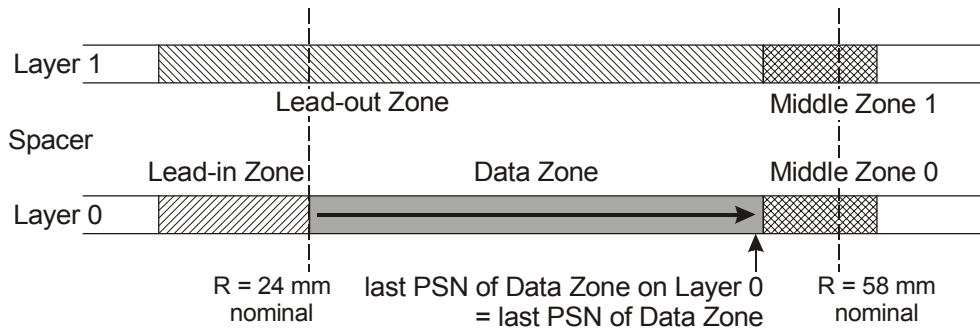

Figure 38 — Example of Finalized disk with only data on Layer 0

22.2 Lead-out Zone at closing of first Session

At closing of the first Session (see 24.2) a Partial Lead-out Zone shall be created on Layer 1 (see Figure 39). For this Partial Lead-out there are two options:

- 1) a nominal Partial Lead-out made up of 21 248 sectors, ranging from address (FD0000) at radius 24,0 mm nominal to address (FD5300) at radius 23,4 mm nominal,
 - 2) an extended Partial Lead-out made up of 283 392 sectors, ranging from address (F90000) at radius 30,4 mm nominal to address (FD5300) at radius 23,4 mm nominal.
- If the layer jump (see 16.1) has been set before to an address < (070000), no extended Partial Lead-out Zone shall be applied.

The pointer to the end of the Data Zone as recorded in the Control Data Zone (see 18.8.1, byte 9 to 11) and in the Table Of Contents Blocks (see 17.6.1, Physical Sector 0 / bytes D₄₁ to D₄₃) shall be set accordingly.

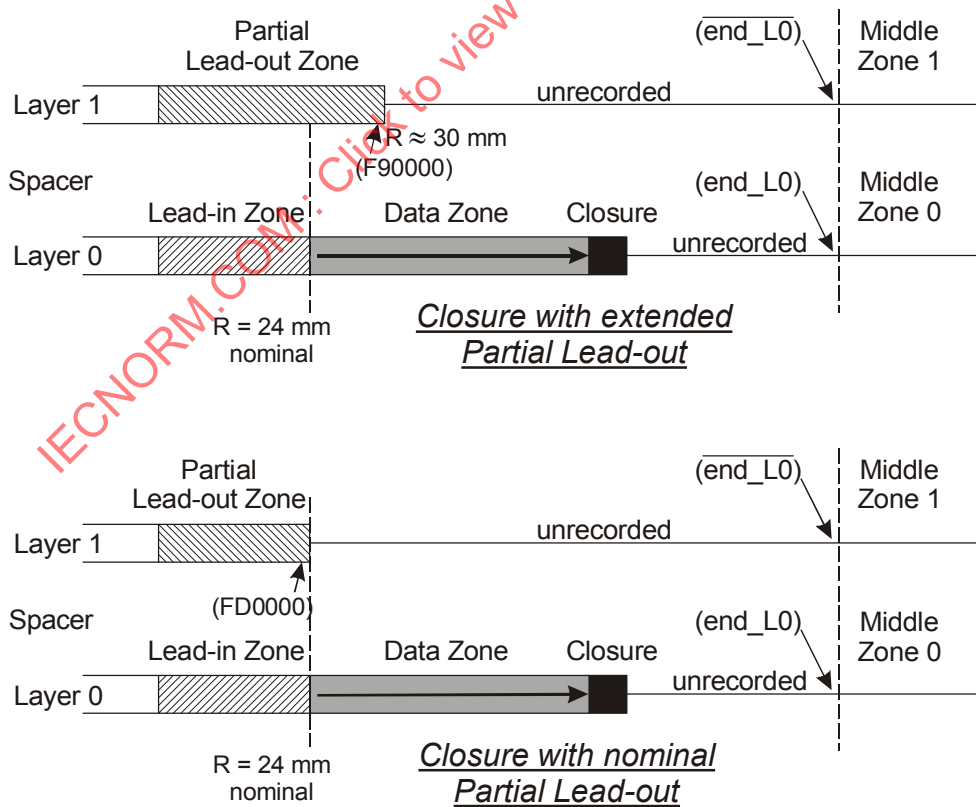

Figure 39 — Lead-out options at closing of first Session

23 Multi-session Layout

To enable data retrieval by Read-Only devices, the disk should have a Lead-in Zone, no blank areas in the Data Zone, and some form of Lead-out Zone. However one also wants to have the ability to append additional data to a partially recorded disk. For this purpose the following Multi-session concept is specified.

On a Multi-session disk there can exist more than one session. A session with an Intro and a Closure is called a Closed Session. The first Session shall be preceded by a Lead-in Zone instead of an Intro Zone, the final Session shall be followed by a Lead-out Zone instead of a Closure Zone. Once a Lead-out Zone has been recorded, the disk is called “finalized” and no additional recordings to the disk shall be allowed.

The general layout of a Multi-session disk is shown in Table 12.

A session with a partially recorded Lead-in or Intro Zone and no Lead-out or Closure Zone is called an Open Session. All sessions must be Closed Sessions, except for the last one, which is allowed to be an Open Session. User Data can only be appended to an Open Session. If all session are closed, a new Open Session has to be created first (see 24.1).

The first Closed Session on the disk shall have a Lead-in that complies with clause 18. Subsequent Closed Sessions shall have an Intro as defined in 23.1. Every Closed Session shall have a Closure as defined in 23.3, except for the Final Session, which shall have a Lead-out as defined in clause 22.

Sessions (and also their Intro's and Closures) are allowed to span the layer jump (see also 16.1).

Table 12 — Layout of the Information Zone of a Multi-session disk

Session	Zone	Description	Number of Physical Sectors
	Inner Drive Area	--	--
Session 1	Lead-in
		Reserved Zone 2	64
		Inner Disk Identification Zone	256
	
		Control Data Zone	3 072
		Buffer Zone 2	512
	Data	Data Zone	min 16
Closure	Buffer Zone C	See 23.3	768
	Outer Session Identification Zone		256
Session 2	Intro	Buffer Zone A	64
		Inner Session Identification Zone	256
		Session Control Data Zone	640
		Buffer Zone B	64
	Data	Data Zone	min 16
	Closure	Buffer Zone C	See 23.3
Outer Session Identification Zone		256	
:	:	:	...
:	:	:	...
Session N ($N \leq 127$)	Intro	...	See 23.1
	Data	Data Zone	min 16
	Lead-out	...	See clause 22

23.1 Intro

Each new Session that occurs after the first Session, shall start with an Intro Zone consisting of a Buffer Zone A, an Inner Session Identification Zone, a Session Control Data Zone and a Buffer Zone B.

All Physical Sectors in the Intro Zone shall have bits b_{27} to b_{26} of the Data Frame set to ZERO ZERO, identifying the Intro Zone as if it was a Data Zone (see 13.1.1).

23.1.1 Buffer Zone A

64 Physical Sectors are reserved and shall be set to (00).

23.1.2 Inner Session Identification Zone

256 Physical Sectors reserved to store information about the Sessions. Each set of 16 Physical Sectors from one ECC Block is either a Disk Control Block (DCB) (see clause 26) or recorded with all (00) Main Data. Each ECC Block in this Zone following one recorded with all (00) Main Data shall also be recorded with all (00) Main Data.

23.1.3 Session Control Data Zone

This Zone shall consist of 640 Physical Sectors from 40 ECC Blocks. The content of the 16 Physical Sectors of each ECC Block is repeated 40 times. The structure of a Control Data Block shall be as shown in Figure 31.

23.1.4 Buffer Zone B

64 Physical Sectors are reserved and shall be set to (00).

23.2 Data Zone

Each Data Zone shall consist of a multiple of 16 Physical Sectors, with a minimum of 16. The first Data Zone shall start at PSN (030000). If needed (e.g. for filling up the last ECC Block or for facilitating compatibility with certain Read-Only drives that require the disk to be recorded up till a certain radius) a Data Zone can be padded with Data Frames containing all (00) Main Data.

23.3 Closure

Each Session shall end with a Closure Zone consisting of two parts; a Buffer Zone C and an Outer Session Identification Zone.

All Physical Sectors in the Closure Zone shall have bits b_{27} to b_{26} of the Data Frame set to ZERO ZERO, identifying the Closure Zone as if it was a Data Zone (see 13.1.1).

23.3.1 Buffer Zone C

768 Physical Sectors are reserved and shall be set to (00).

23.3.2 Outer Session Identification Zone

Each set of 16 Physical Sectors from one ECC Block is either a Disk Control Block (DCB) (see clause 2626.2) or recorded with all (00) Main Data. The contents of this Zone shall be equivalent to the contents of the Inner Identification Zone of the same Session.

24 Sequential recording in Fragments

+R DL disks according to this document in principle have to be recorded sequentially. To facilitate the recording of specific data at some pre-determined location on the disk at a later moment in time (such as for instance File System information), a Session can be divided into a number of Fragments. Inside such a Fragment the User Data shall be recorded sequentially in the direction of increasing addresses.

24.1 Opening a Session

New data can be added to the disk by appending to an Open Session. If there is no Open Session, a new Session has to be opened (see Table 13).

A new Session is opened by recording Buffer Zone A plus an SDCB (Session Disk Control Block: see 26.2) in the first ECC Block of the Inner Session Identification Zone (or by recording Reserved Zone 2 plus an SDCB in the first ECC Block of the Inner Disk Identification Zone in case of the first Session on a blank disk).

Once the first ECC Block of the Data Zone is recorded, also Buffer Zone B of the Intro (or Buffer Zone 2 of the Lead-in Zone in case of the first Session) shall be recorded.

24.1.1 Incomplete Fragment

When no Reserved Fragments (see 24.1.2) are created, all the remaining area of the Data Zone following Buffer Zone B is called the Incomplete Fragment. In the presence of Reserved Fragments, all the remaining area of the Data Zone following the last Reserved Fragment is called the Incomplete Fragment.

Until the Incomplete Fragment is closed (see 24.1.4), there shall be no Fragment item (see 26.2.1) for the Incomplete Fragment in any SDCB.

Table 13 — Details of opened Session n (example)

	<u>Data</u>	Data Zone	User Data	
Session n-1		Buffer Zone C	48 ECC Blocks with (00)	
	<u>Closure</u>	Outer Session Identification Zone	16 ECC Blocks with DCBs and/or (00)	
Session n	<u>Intro</u>	Buffer Zone A	4 ECC Blocks with (00)	
		Inner Session Identification Zone	1 ECC Block with an SDCB	
			blank	
		Session Control Data Zone	blank	
	Buffer Zone B	4 ECC Blocks with (00)		
	<u>Data</u>	Data Zone	Reserved Fragment (optional)	
			1 ECC Block for Run-in	
Incomplete Fragment with User Data				
blank				

24.1.2 Reserved Fragments

To allow for later on adding data, preceding already recorded User Data (such as for instance File System information), it is possible to create so-called Reserved Fragments. All Reserved Fragments in the Open Session shall be contiguous and non-overlapping, while the first Fragment shall start immediately after the end of Buffer Zone B.

Between any 2 Fragments there shall be 1 ECC Block for Run-in purposes. This ECC Block does not belong to any of the Fragments, and shall be recorded after the end of Reserved Fragment i at the same time the first ECC Block of Fragment $(i+1)$ is recorded. (see Figure 40)

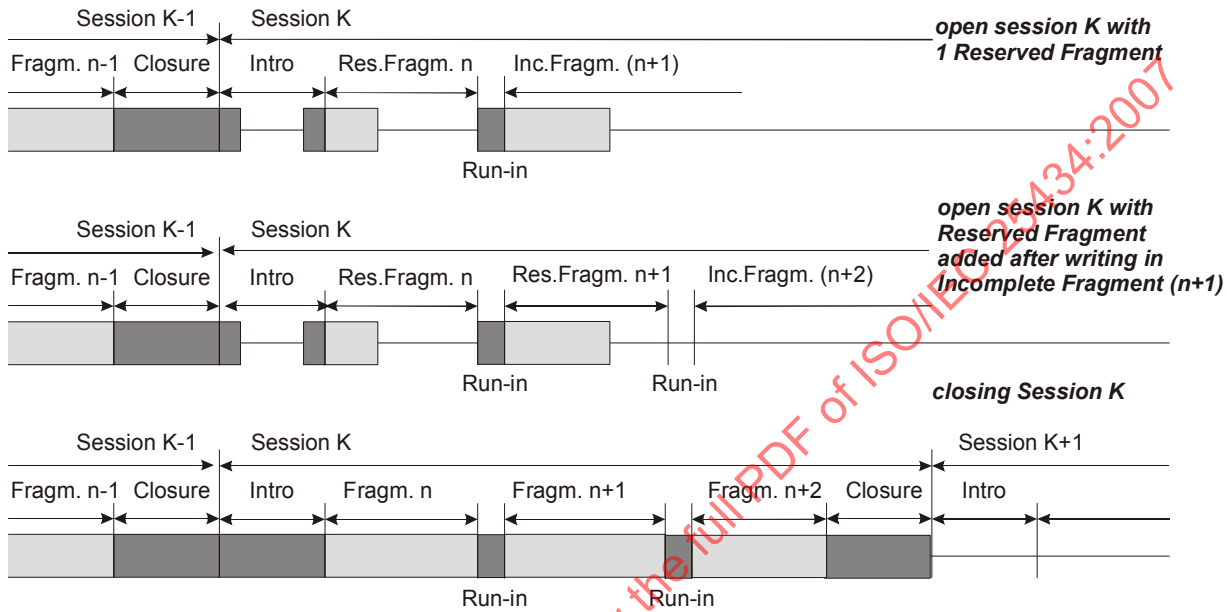

Figure 40 — Creating Reserved Fragments

24.1.2.1 Adding a Reserved Fragment

If a new Reserved Fragment is defined, this Fragment shall start from the beginning of the Incomplete Fragment and at least include all data that have already been written to the Incomplete Fragment. The newly defined Reserved Fragment shall be Fragment $n+1$, where n is the number of the previously last (Reserved) Fragment. A new SDCB shall be recorded in the Identification Zone of the Session including a new Fragment item indicating the start and end addresses of the added Reserved Fragment (see 26.2.1).

Reserved Fragments can only be added as long as the number of free locations for SDCBs in the Inner Identification Zone of the current Session is larger than one. The last free location for an SDCB has to be preserved for closing the Session.

The area following the newly defined Reserved Fragment is designated to be the new Incomplete Fragment $(n+2)$.

24.1.3 Recording User Data in Fragments

User Data added to the Data Zone shall be linked immediately to previously written User Data in the Incomplete Fragment or to previously written data in one of the Reserved Fragments.

24.1.4 Closing a Fragment

When a Reserved Fragment is closed, all blank areas in the Fragment shall be recorded with dummy data.

When the Incomplete Fragment is closed, a new SDCB shall be recorded in the Identification Zone of the Session including a new Fragment item indicating the start and end addresses of the (formerly) Incomplete Fragment (see 26.2). This formerly Incomplete Fragment shall not have unrecorded areas.

The area after the formerly Incomplete Fragment can be designated as the new Incomplete Fragment if case more User Data has to be added. For consistency reasons a Run-in Block shall be taken into account between the new Incomplete Fragment and the formerly Incomplete Fragment.

24.2 Closing a Session

To enable data retrieval from a Session by Read-Only devices, this Session and all preceding ones should be closed. A Session is closed by recording all blank areas in all Fragments with dummy data and recording all remaining parts in the Lead-in or Intro Zone and adding the Closure Zone.

When a Session is closed, the Incomplete Fragment is closed and shall be designated as Fragment $m+1$, where m is the number of the last (Reserved) Fragment preceding the Incomplete Fragment. (see Figure 40).

The numbering of the Fragments shall be continuous over all Sessions. (see Figure 40).

At closing of the first Session a Partial Lead-out Zone as specified in clause 22 shall be recorded.

At closing of the Session crossing the layer jump the Middle Zones as specified in clause 20 shall be recorded.

When the Session to be closed is the 127th Session, then the disk shall be Fully Finalized, instead of closing the Session (see 24.3).

Also when the remaining free space on the disk after closing the Session will become less than 128 ECC Blocks (2 048 Physical Sectors), the disk shall be Fully Finalized, instead of closing the Session (see 24.3).

24.2.1 Lead-in/Intro Zone

The SDCB shall be updated, including the Incomplete Fragment as the last Fragment ($n+2$ in the example of Figure 40). In case multiple SDCBs have been recorded, the last written SDCB is the valid one.

In the Lead-in Zone the Control Data Zone shall be according to 18.8.

In each Intro the Session Control Data Zone shall be recorded with 40 ECC Blocks according to the format specified in 18.8 with the following settings:

Physical Format Information:

Bytes 0 to 247 - same as in 18.8.1

These bytes contain a copy of the Physical format information for Layer 0.

Bytes 248 to 251 – Start of current Session

Byte 248 shall be set to (00).

Bytes 249 to 251 shall specify the Sector Number of the first Physical Sector of the Data Zone of the current Session (see clause 23).

Bytes 252 to 255 – End of current Session

Byte 252 shall be set to (00).

Bytes 253 to 255 shall specify the Sector Number of the last Physical Sector of the Data Zone of the current Session (see clause 23).

Bytes 256 to 511 - same as in 18.8.1

These bytes contain a copy of the Physical format information for Layer 1.

Bytes 512 to 2 047 - Reserved - All (00)

These remaining bytes have no relation to the ADIP information and shall be set to all (00).

Disk manufacturing information: see 18.8.2

Content provider information: see 18.8.3

24.2.2 Closure Zone

At closing a Session, Buffer Zone C shall be recorded together with the Outer Session Identification Zone.

24.3 Finalizing the disk

When the disk is being finalized, a Lead-out Zone according to clause 22 shall be recorded instead of a Closure Zone. After finalizing the disk, adding data is no longer possible. The Session Status in the TOC Item describing the last Session shall be set accordingly (see 17.6.1.1: TOC Item, byte B₃).

25 Assignment of Logical Sector Numbers (LSNs)

Logical Sector Numbers (LSNs) shall be assigned contiguously increasing by one from LSN 0, starting from the first PSN (030000) to PSN (end_L0) on Layer 0 and then continuing uninterrupted from PSN (end_L0) to PSN (FCFFFF) on Layer 1 (see Figure 24).

Let the total capacity of the two layers of the disk be = 2C,
where C = (end_L0) - (02FFFF) and (end_L0) is the actual last PSN of the Data Zone on Layer 0 (see 16.1).

The relation between LSN and PSN shall be

on Layer 0: $LSN = PSN - (030000)$

on Layer 1: $LSN = PSN - (FD0000) + 2C$

26 Disk Control Blocks

Disk Control ECC Blocks are provided as a structure on the disk to include additional information for interchange between the data interchange parties. DCBs are recorded in the Inner and Outer Identification Zones of the disk and the Sessions. All DCBs shall have the same format for the first 40 data bytes. A special DCB is defined to reflect the status of the Session(s).

26.1 General format of Disk Control Blocks

The Main Data of each Disk Control Block shall be according to Table 14.

If a Disk Control Block has to be updated, a substitute DCB shall be written immediately following the last written DCB in the Inner Disk/Session Identification Zone. If more than one DCB with the same Content Descriptor are present, then the one with the highest address is the only valid one of that type. Once a Session has been closed, the DCBs of that Session can no longer be updated.

Table 14 — General format of each Disk Control Block

Physical Sector of each DCB	Main Data BP	Description
0	D ₀ to D ₃	Content Descriptor
0	D ₄ to D ₇	Unknown Content Descriptor Actions
0	D ₈ to D ₃₉	Drive ID
0	D ₄₀ to D _{2 047}	Content Descriptor Specific
1 to 15	D ₀ - D _{2 047}	Content Descriptor Specific

Bytes D₀ to D₃ - Content Descriptor

If set to (00000000)

the DCB is unused.

The Content Descriptor of all subsequent DCBs in this Inner or Outer Identification Zone shall be set to (00000000).

All remaining bytes, D₄ to D_{2 047} of Physical Sector 0 and D₀ to D_{2 047} of Physical Sector 1 to 15 in Table 14 shall be set to (00).

If set to (53444300)

this DCB shall be as defined in 26.2.

All other values for the Content Descriptor are reserved.

Each new DCB added to the Inner or the Outer Identification Zone shall be written at the first available unwritten DCB location.

Each prevailing DCB with a Content Descriptor not set to (00000000) in the Inner Identification Zone of a Session shall have an identical DCB in the Outer Identification Zone of the respective Session (DCBs that have been substituted need not to be present in the Outer Identification Zone).

Bytes D₄ to D₇ - Unknown Content Descriptor Actions

These bits are provided to specify required actions when the content and use of the DCB are unknown to the drive (i.e. the content descriptor is not set to a known assigned value). These bytes form a field consisting of 32 individual bits.

Bits b₃₁ to b₄ Reserved,

these bits shall be set to all ZERO.

- Bit b_3 DCB rewrite,
if set to ONE, substituting the current DCB shall not be allowed,
else it shall be set to ZERO.
- Bit b_2 Formatting,
shall be set to ONE, indicating that reformatting of the disk is not possible.
- Bit b_1 DCB read protect,
if set to ONE, the information in this DCB is meant for use by the drive only and shall not be transferred outside the drive,
else it shall be set ZERO.
- Bit b_0 Data Zone write,
if set to ONE, recording shall not be allowed in the Data Zone,
else it shall be set to ZERO.

Bytes D_8 to D_{39} Drive ID

Bytes D_8 to D_{39} shall contain a unique descriptor, identifying the drive that has written the DCB. The format of this unique drive identifier shall be as follows:

- Bytes D_8 to D_{23} shall identify the manufacturer of the drive. This name shall be represented by characters from the G0 set + SPACE according to Standard ISO/IEC 4873. Trailing bytes not used shall be set to (00).
- Bytes D_{24} to D_{35} shall identify the model name/type number of the drive. This model name/type number shall be represented by characters from the G0 set + SPACE according to Standard ISO/IEC 4873. Trailing bytes not used shall be set to (00).
- Bytes D_{36} to D_{39} shall contain a unique serial number of the drive. The 4 bytes shall form one 32-bit binary number.

Bytes D_{40} to $D_{2\ 047}$ Content Descriptor Specific

Bytes specified by the format description for the DCB with the actual Content Descriptor value.

Physical Sectors 1 to 15: Bytes D_0 to $D_{2\ 047}$ Content Descriptor Specific

Bytes specified by the format description for the DCB with the actual Content Descriptor value.

26.2 Format of the Session DCB (SDCB)

The Lead-in or Intro Zone of an Open Session shall contain an SDCB describing the structure of the Open Session and the location of all previous Sessions. When the Session is closed, the SDCB in the Inner Identification Zone shall be updated and a copy shall be written to the Outer Identification Zone. The SDCB's shall have the content as defined in Table 15.

Physical Sector 0 / bytes D₀ to D₃ – Content Descriptor

These bytes identify the Session DCB and shall be set to (53444300), representing the characters “SDC” and the version number 0.

Physical Sector 0 / bytes D₄ to D₇ – Unknown Content Descriptor Actions

Shall be set to (0000000D) indicating that if this DCB is not known to the system, the DCB shall not be substituted, the disk can not be reformatted, writing to the Data Zone shall not be allowed, while transferring the DCB information from the drive to the host computer is allowed.

Table 15 — Format of the SDCB

Physical Sector of ECC block	Main Data byte position	Description	number of bytes
0	D ₀ to D ₃	Content Descriptor	4
0	D ₄ to D ₇	Unknown Content Descriptor Actions	4
0	D ₈ to D ₃₉	Drive ID	32
0	D ₄₀ to D ₄₁	Session number	2
0	D ₄₂ to D ₆₃	Reserved and set to (00)	22
0	D ₆₄ to D ₉₅	Disk ID (in Lead-in Zone only)	32
0	D ₉₆ to D ₁₂₇	Application Dependent	32
0	D ₁₂₈ to D ₁₄₃	Session Item 0	16
0	
0	D _{128+i×16} to D _{143+i×16}	Session Item i	16
0	
0	D _{128+(N-1)×16} to D _{143+(N-1)×16}	Session Item N-1	16
0	D _{128+N×16} to D _{2 047}	Reserved and set to (00)	1 920 - N×16
1 to 3	D ₀ to D _{2 047}	Extension for Session Items or Reserved and set to (00)	3×2 048
4 to 7	D ₀ to D _{2 047}	Repetition of Sectors 0 to 3 (recommended) or Reserved and set to (00)	4×2 048
8 to 11	D ₀ to D _{2 047}	Repetition of Sectors 0 to 3 (recommended) or Reserved and set to (00)	4×2 048
12 to 15	D ₀ to D _{2 047}	Repetition of Sectors 0 to 3 (recommended) or Reserved and set to (00)	4×2 048

Physical Sector 0 / bytes D₈ to D₃₉ – Drive ID

These bytes shall contain the drive ID as specified in 26.1, bytes D₈ to D₃₉.

Physical Sector 0 / bytes D₄₀ to D₄₁ – Session number

These bytes shall specify the sequence number of the Session to which the SDCB belongs. The first Session shall have sequence number 1 and each subsequent Session number shall be incremented by one.

Physical Sector 0 / bytes D₄₂ to D₆₃ – Reserved

These bytes are reserved and shall be set to (00).

Physical Sector 0 / bytes D₆₄ to D₉₅ – Disk ID

In the SDCB in the Inner Disk Identification Zone in the Lead-in Zone of the disk, these 32 bytes shall be recorded with a random, statistically unique, 256-bit binary number at initialization of the disk (opening of the first Session). In the SDCB in the Inner Session Identification Zone in the Intro of each next Session, bytes D₆₄ to D₉₅ shall be set to all (00).

Physical Sector 0 / bytes D₉₆ to D₁₂₇ – Application dependent

This field shall consist of 32 bytes and is reserved for use by the application to store information such as specific copy protection data. If this setting is not specified by the application, the bytes shall be set to (00).

In each Session these bytes may be set independently.

Physical Sector 0 / bytes D₁₂₈ to D_{2 047} – Session Items

These bytes are grouped in units of 16 bytes each. Each unit of 16 bytes may contain one of two different types of Session Items:

- type 1: specifies the Fragments in the current Session,
- type 2: specifies the start and end addresses of all previous Sessions.

All Session Items shall be ordered in the SDCB according to their type number (first type 1, then type 2).

All bytes not containing Session Items shall be set to (00).

Physical Sectors 1 to 3 / bytes D₀ to D_{2 047} – Extension for Session Items or Reserved

These bytes may hold additional Session Items.

All bytes not containing Session Items shall be set to (00).

Physical Sectors 4 to 15 / bytes D₀ to D_{2 047} – 3 Repetitions of Sectors 0 to 3 or all Reserved

For robustness reasons it is recommended to repeat the content of Sectors 0 to 3 in Sectors 4 to 7, in Sectors 8 to 11 and in Sectors 12 to 15.

If this option is not used, these bytes shall be set to (00).

It is a matter of drive implementation to recognize and make use of the repetitions.

26.2.1 Session Items

26.2.1.1 type 1: Fragment item

Item byte position	Description	number of bytes
B ₀ to B ₂	Fragment item descriptor	3
B ₃ to B ₄	Fragment number	2
B ₅ to B ₇	Fragment start address	3
B ₈ to B ₁₀	Fragment end address	3
B ₁₁ to B ₁₅	Reserved and set to (00)	5

An SDCB shall contain a Fragment item for each Reserved Fragment in the Session. If there are no Reserved Fragments, there shall be no Fragment items.

If a new Reserved Fragment has to be added to an Open Session, a new SDCB, including the Fragment items needed to reflect the new situation, is written in the Inner Identification Zone of the current Session, immediately following the last SDCB. Reserved Fragments in a Session shall not be overlapping.

When closing a Session, a new SDCB, including a Fragment item for the Incomplete Fragment, is written in the Inner Identification Zone of the current Session, immediately following the last SDCB.

The Fragment items shall be ordered with increasing numbers and addresses. The last written SDCB in the Inner Identification Zone is the valid SDCB.

Fragment item bytes B₀ to B₂ – Fragment item descriptor

These 3 bytes identify the item type and shall be set to (465247), representing the characters “FRG”.

Fragment item bytes B₃ to B₄ – Fragment number

These 2 bytes shall specify the sequence number of the Fragment. The numbers of the Fragments shall be contiguous over all Sessions and increment by one for each subsequent Fragment. The first Fragment in the first Session shall have sequence number 1 and the first Fragment in each next Session shall have a sequence number that is one higher than the number of the last Fragment in the preceding Session.

Fragment item bytes B₅ to B₇ – Fragment start address

These 3 bytes shall specify the PSN of the first Physical Sector belonging to the Fragment specified in this item.

Fragment item bytes B₈ to B₁₀ – Fragment end address

These 3 bytes shall specify the PSN of the last Physical Sector belonging to the Fragment specified in this item.

Fragment item bytes B₁₁ to B₁₅ – Reserved

These 5 bytes are reserved and shall be set to (00).

26.2.1.2 type 2: Previous Session item

Item byte position	Description	number of bytes
B ₀ to B ₂	Previous Session item descriptor	3
B ₃	Reserved and set to (00)	1
B ₄	Previous Session number	1
B ₅ to B ₇	Previous Session start address	3
B ₈ to B ₁₀	Previous Session end address	3
B ₁₁ to B ₁₅	Reserved and set to (00)	5

An SDCB shall contain a Previous Session item for each Session preceding the current Session. The SDCB of the first Session shall not contain a Previous Session item. The Previous Session items shall be ordered with increasing addresses.

Previous Session item bytes B₀ to B₂ – Previous Session item descriptor

These 3 bytes identify the item type and shall be set to (505253), representing the characters “PRS”.

Previous Session item byte B₃ – Reserved

This byte is reserved and shall be set to (00).

Previous Session item byte B₄ – Previous Session number

This byte shall specify the sequence number of the Previous Session specified in this item.

Previous Session item bytes B₅ to B₇ – Previous Session start address

These 3 bytes shall specify the PSN of the first Physical Sector in the Data Zone of the Previous Session specified in this item.

Previous Session item bytes B₈ to B₁₀ – Previous Session end address

These 3 bytes shall specify the PSN of the last Physical Sector in the Data Zone of the Previous Session specified in this item.

Previous Session item bytes B₁₁ to B₁₅ – Reserved

These 5 bytes are reserved and shall be set to (00).

Section 5 - Characteristics of the groove

27 General

All recordings shall occur only in grooved areas. The groove centreline is deviated from the average track centreline with a phase modulated sine-wave. Physical addressing information can be decoded from this phase modulated wobble.

The format of the groove information on the disk is defined in 14.4. Clause 29 specifies the requirements for the signals from grooves on both layers, as obtained when using the Reference Drive as defined in clause 9.

28 Method of testing

28.1 Environment

All signals in clause 29 shall be within their specified ranges with the disk in the test environment conditions defined in 9.

28.2 Reference Drive

All signals specified in clause 29 shall be measured in the indicated channels of the Reference Drive as defined in clause 9. The drive shall have the following characteristics for the purpose of these tests.

28.2.1 Optics and mechanics

The focused optical beam shall have the properties defined in 9.2 a) to i). The disk shall rotate as specified in 9.5.

28.2.2 Read power

The optical power incident on the read-out surface of the disk (used for reading the information) shall be $0,7 \text{ mW} \pm 0,1 \text{ mW}$.

28.2.3 Read channels

The drive shall have two read channels. Read Channel 1 gives a signal $(I_1 + I_2)$ related to the total amount of light in the exit pupil of the objective lens. Read Channel 2 gives a signal $(I_1 - I_2)$ related to the difference in the amount of light in the two halves of the exit pupil of the objective lens. These channels can be implemented as given in clause 9.

For measurement of the push-pull and track cross signals, the read channel signals shall be filtered by a 1st order LPF with a f_c (-3 dB) of 30 kHz.

For measurement of the wobble signal, the read channel signals shall be filtered by a 1st order Band Pass Filter with frequency range (-3 dB): 25 kHz, slope +20 dB/decade to 4,0 MHz, slope -20 dB/decade.

28.2.4 Tracking

During the measurement of the signals, the axial tracking error between the focus of the optical beam and the recording layer shall not exceed $0,20 \text{ } \mu\text{m}$;

the radial tracking error between the focus of the optical beam and the centre of a track shall not exceed $0,022 \text{ } \mu\text{m}$.

28.3 Definition of signals

All signals are linearly related to currents through a photo detector, and are therefore linearly related to the optical power falling on the detector.

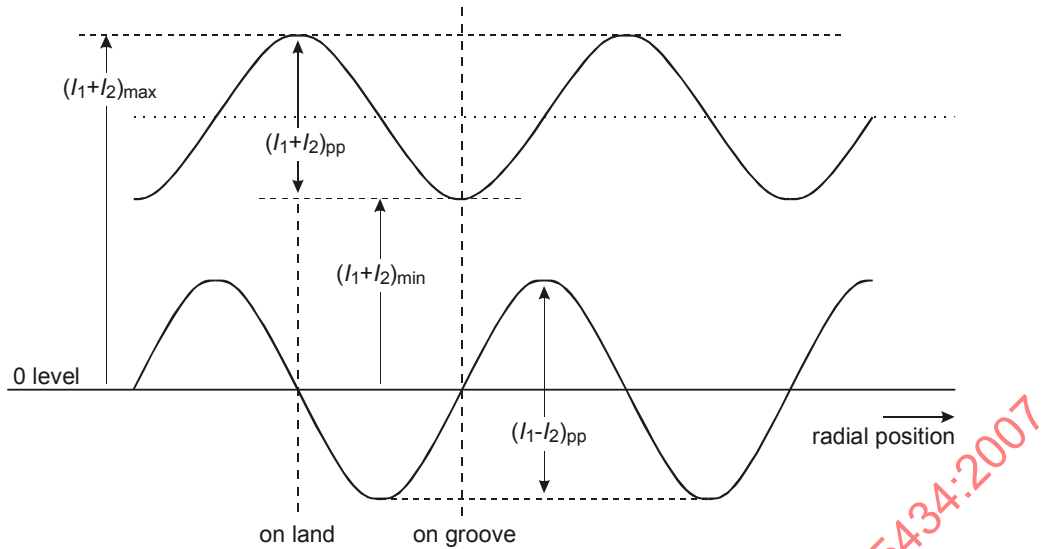

Figure 41 — Signals from grooves in the Read Channels when crossing the tracks

Push-pull signal

The push-pull signal is the filtered sinusoidal difference signal $(I_1 - I_2)$ in Read Channel 2, when the focus of the optical beam crosses the tracks. The signal can be used by the drive for radial tracking.

Track cross signal

The track cross signal is the filtered sinusoidal sum signal $(I_1 + I_2)$ in Read Channel 1, when the focus of the optical beam crosses the tracks.

Wobble signal

The wobble signal I_W is the filtered sinusoidal difference signal $(I_1 - I_2)$ in Read Channel 2, while the drive meets the minimum tracking requirement.

29 Characteristics of the groove signals

29.1 Phase depth

The phase depth of the groove on each layer shall not exceed 90°.

29.2 Push-pull signal

The peak-to-peak value of the push-pull signal PP shall meet the following requirements:

a) on Layer 0 before recording:
$$0,28 \leq \frac{(I_1 - I_2)_{pp}}{[(I_1 + I_2)_{max} + (I_1 + I_2)_{min}]/2} \leq 0,60$$

on Layer 1 before recording:
$$0,30 \leq \frac{(I_1 - I_2)_{pp}}{[(I_1 + I_2)_{max} + (I_1 + I_2)_{min}]/2} \leq 0,60$$

The max variation of the push-pull signal within one layer before recording shall be:

$$\frac{PP_{\max} - PP_{\min}}{PP_{\max} + PP_{\min}} < 0,15$$

b) on both layers after recording: $0,30 \leq \frac{(I_1 - I_2)_{pp}}{[(I_1 + I_2)_{\max} + (I_1 + I_2)_{\min}]/2} \leq 0,80$

c) Ratio of push-pull signal of unrecorded groove to push-pull signal of recorded groove within one layer shall be in the range of: $0,60 \leq \frac{PP_{\text{before}}}{PP_{\text{after}}} \leq 1,10$

29.3 Track Cross signal

The Track Cross signal for the unrecorded disk is not specified.

29.4 Normalized wobble signal

The deviation from the track centreline shall be measured by the normalized wobble signal. The amount of distance that the centre of the wobble groove deviates from the average track centreline can be calculated according to Annex M.

The wobble signal shall be measured in an empty track during the monotone wobble part, at locations where the amplitude is not enhanced due to the positive interference of the wobble from adjacent tracks and where the other layer is unrecorded.

The normalized wobble signal shall be

$$0,15 \leq \frac{I_{W,pp-\min}}{(I_1 - I_2)_{pp}} \leq 0,30$$

At locations where the amplitude of the wobble signal is enhanced due to the positive interference of the wobble from adjacent tracks, the maximum wobble signal shall be

$$\frac{I_{W,pp-\max}}{I_{W,pp-\min}} \leq 2,6$$

29.5 Characteristics of the wobble

The average Narrow band SNR of the wobble signal before recording shall be greater than 45 dB. The measurement shall be made using a resolution bandwidth of 1 kHz. At the location of the measurement the other layer shall be unrecorded.

The average Narrow band SNR of the wobble signal after recording shall be greater than 36 dB. The measurement shall be made using a resolution bandwidth of 1 kHz. At the location of the measurement the other layer shall be recorded.

Section 6 - Characteristics of the recording layer

30 Method of testing

The format of the information on the disk is defined in clause 13. Clause 31 specifies the requirements for the signals from recorded grooves on both layers, as obtained when using the Reference Drive as defined in clause 9.

This clause 31 specifies the average quality of the recorded information. Local deviations from the specified values, called defects, can cause tracking errors or errors in the Data fields. These errors are covered by Clause 33 and Section 7.

30.1 Environment

All signals in 31.2.2 to 31.2.6 shall be within their specified ranges with the disk in the test environment conditions defined in 8.1.1.

30.2 Reference Drive

All signals specified in 31.2.2 to 31.2.6 shall be measured in the indicated channels of the Reference Drive as defined in clause 9. The drive shall have the following characteristics for the purpose of these tests.

30.2.1 Optics and mechanics

The focused optical beam shall have the properties defined in 9.2 a) to i). The disk shall rotate as specified in 9.5.

30.2.2 Read power

The optical power incident on the read-out surface of the disk (used for reading the information) shall be $0,7 \text{ mW} \pm 0,1 \text{ mW}$.

30.2.3 Read channels

The drive shall have two read channels. Read Channel 1 gives a signal $(I_1 + I_2)$ related to the total amount of light in the exit pupil of the objective lens. Read Channel 2 gives a signal $(I_1 - I_2)$ related to the difference in the amount of light in the two halves of the exit pupil of the objective lens. These channels can be implemented as given in clause 9.

For measurement of the push-pull and track cross signals, the read channel signals shall be filtered by a 1st order LPF with a f_c (-3 dB) of 30 kHz.

The signal from Read channel 1 is not equalized except when measuring jitter. The threshold level for binarizing the read signal shall be controlled to minimize the effects of mark and space size changes due to parameter variations during writing. Jitter measurements shall be made using the Read Channel 1 with the characteristics in Annex E.

30.2.4 Tracking

During recording and during the measurement of the signals, the axial tracking error between the focus of the optical beam and the recording layer shall not exceed $0,20 \text{ }\mu\text{m}$;

the radial tracking error between the focus of the optical beam and the centre of a track shall not exceed $0,022 \text{ }\mu\text{m}$ when running at the Reference velocity and shall not exceed $0,045 \text{ }\mu\text{m}$ when running at a higher velocity.

NOTE At high recording or playback velocities, advanced servo systems might be needed to achieve tracking errors below these maximum values.

30.2.5 Scanning velocity

All write tests are performed at the velocities of the disk defined in 14.4.2. The disk shall be tested at all Primary/Lower, Intermediate and Upper speeds with the related write strategy.

All read tests are performed at the Reference velocity.

30.3 Write conditions

Marks and spaces are written on the disk by pulsing a laser.

30.3.1 Write pulse waveform

The laser power is modulated according to the write pulse waveforms given in Annex G.

A 3T to 14T mark is written by applying a multiple-pulse train of short write pulses or by applying a single write pulse.

The recording power has two basic levels: the Write power (P_w) and the Bias power (P_b), which are the optical powers incident at the entrance surface of the disk and used for writing marks and spaces.

In case of the single write pulse, a power enhancement dP_w can be applied depending on the type and the length of the pulses; furthermore for optimum cooling of the recording layer after writing a mark, the power shall be switched to the lowest possible level (P_c) for some time immediately following the write pulse (see Annex G.2).

The value of the P_w power level shall be optimized according to Annex I.

The actual P_w power level shall be within 5 % of its optimum value.

30.3.2 Write power

The optimized recording powers, P_{wo} and P_{bo} shall meet the following conditions.

$P_{peak} = P_{wo}$ in case no power enhancement is applied and

$P_{peak} = P_{wo} + dP_{wo}(\text{max applied for any mark})$ in case power enhancement is applied.

For the **basic write strategy** defined in 14.4.2.2:

$$P_{peak} \leq 30,0 \text{ mW for } 650 \text{ nm} \leq \lambda \leq \lambda_{IND}$$

$$P_{peak} \leq 35,0 \text{ mW for } \lambda_{IND} < \lambda \leq 665 \text{ nm}$$

For the **“3,3x+” write strategy** defined in 14.4.2.3.1:

for speeds up to and including 6x:

$$P_{peak} \leq 45,0 \text{ mW for } 650 \text{ nm} \leq \lambda \leq \lambda_{IND}$$

$$P_{peak} \leq 53,0 \text{ mW for } \lambda_{IND} < \lambda \leq 665 \text{ nm}$$

for speeds up to and including 8x:

$$P_{peak} \leq 50,0 \text{ mW for } 650 \text{ nm} \leq \lambda \leq \lambda_{IND}$$

$$P_{peak} \leq 58,0 \text{ mW for } \lambda_{IND} < \lambda \leq 665 \text{ nm}$$

$$P_{wo} \geq 10 \text{ mW at } \lambda = \lambda_{IND}$$

$P_{bo} = 0,7 \pm 0,1 \text{ mW}$

$P_{co} < 0,1 \text{ mW}$

30.3.3 Write power dependency on wavelength

The change of the optimum write power P_{wo} induced by a change of the laser wavelength (see Annex K) shall meet the following condition for each recording layer of the composite disk

$$0 \leq (dP_{wo}/d\lambda)/(P_{IND}/\lambda_{IND}) \leq 25$$

($dP_{wo}/d\lambda$ averaged over the wavelength range from 645 nm to 670 nm)

30.3.4 Write power window

To allow for some variations in the write power of practical drive implementations, the normalized write power windows (NWPW) shall have a minimum width. The normalized write power windows shall be determined in the following way:

- the jitter is measured as a function of the write power P_w at the inner diameter of the Data Zone and at the outer diameter of the Data Zone; in general those two curves will not coincide (see Figure 42),
- the single write power window is defined as the power range ($P_{upper,n} - P_{lower,n}$) where the jitter curve concerned is below 9 % (see Figure 42),

the requirement for each normalized single write power window is:

$$NWPW_S = \frac{P_{upper,n} - P_{lower,n}}{(P_{upper,n} + P_{lower,n})/2} \geq 0,12$$

- the net write power window is defined as the power range where both jitter curves are below 9 % (see example in Figure 42, where the net power window = $P_{upper,1} - P_{lower,2}$),

the requirement for the normalized net write power window is:

$$NWPW_N = \frac{P_{upper,m} - P_{lower,n}}{(P_{upper,m} + P_{lower,n})/2} \geq 0,10$$

in which $P_{upper,m}$ is the highest power at which both jitter curves are below 9 % and $P_{lower,n}$ is the lowest power at which both jitter curves are below 9 %

- the above requirements shall be fulfilled on both layers and at all defined recording velocities

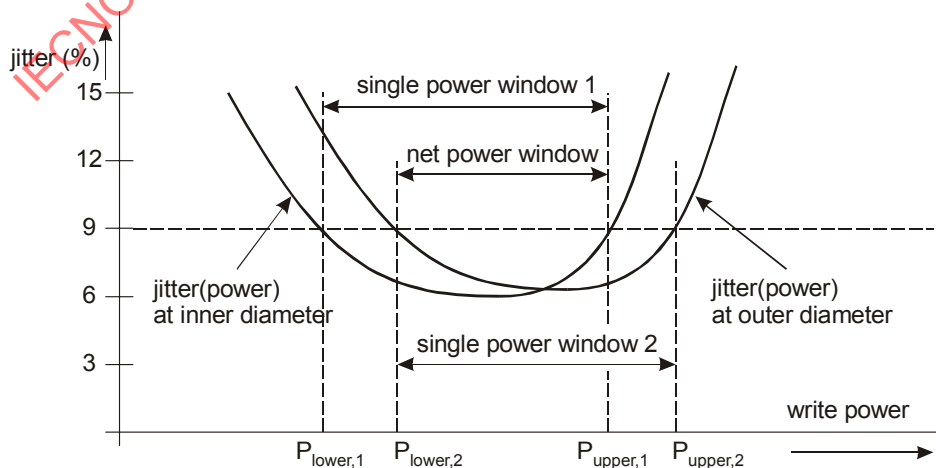

Figure 42 — Example of the write power windows

NOTE Above procedures are based on typical disks which show a monotonic shift of the power window as function of the radius. If this is not the case, power windows shall be measured at several radii and the net power window shall be defined as the power range where all jitter curves are below 9 %.

30.3.5 Write power shift for layer L1 due to recording on layer L0

Depending on the recorded/unrecorded status of layer L0, the optimum write power for layer L1 might exhibit some difference. This difference shall fulfil the following requirement:

$$0,95 \leq \frac{P_{W_{onL1,unrecL0}}}{P_{W_{onL1,recL0}}} \leq 1,05$$

30.4 Measurement conditions

The test for jitter shall be carried out on any group of five adjacent tracks, designated (m-2), (m-1), m, (m+1), (m+2), in the Information Zone of the disk. The jitter shall be measured on recordings made at the two velocities specified in 14.4.2.2, byte 32 and 33 and in the Extended Information blocks defined under 14.4.2.3.

For measurement of jitter the system described in Annex E shall be used.

The Jitter shall be measured according to the following procedure:

Write random data on all five tracks as specified in 30.3.1.

Read the data of track m under the conditions specified in 30.2.

31 Characteristics of the recorded signals

The following signals shall be measured, after recording with the write conditions as specified in 30.3.1.

31.1 Channel bit length

The average Channel bit length over each RUN shall be

$$146,6 \text{ nm} \pm 1,4 \text{ nm}$$

31.2 Definition of signals

All signals are linearly related to currents through a photo-diode detector, and are therefore linearly related to the optical power falling on the detector.

31.2.1 High frequency signals (HF)

The HF signal is obtained by summing the currents of the four elements of the photo detector as generated in Read Channel 1. These currents are modulated by the effects of the marks and spaces representing the information on the recording layer.

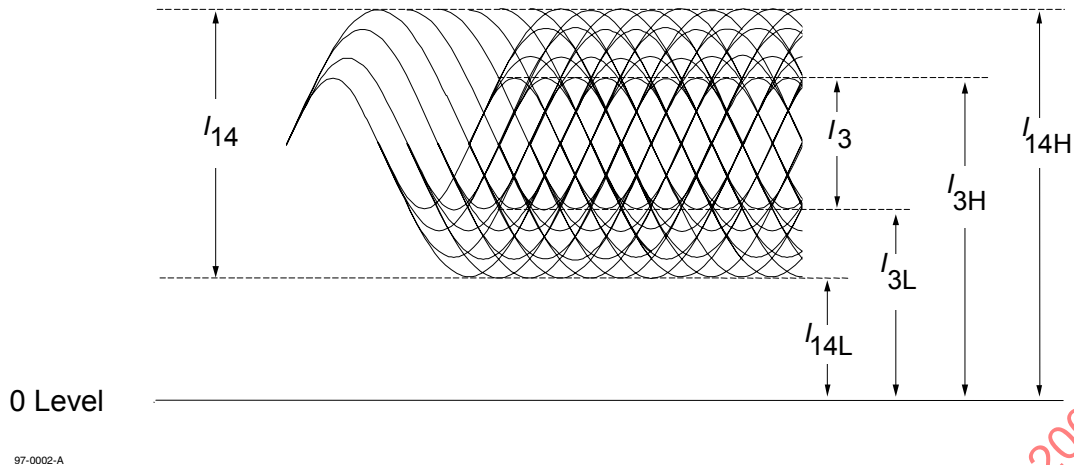

Figure 43 — Signals from spaces and marks in Read channel 1

31.2.2 Modulated amplitude

The modulated amplitude l_{14} is the peak-to-peak value of the HF signal generated by the largest mark and space lengths (see Figure 43). The peak value l_{14H} shall be the peak value of the HF signal before a.c. coupling. The modulated amplitude l_3 is the peak-to-peak value generated by the shortest mark and space lengths. The 0 Level is the signal level obtained from the measuring device when no disk is inserted. These parameters shall meet the following requirements under all conditions, also such as when recordings have been made at different speeds.

$$l_{14} / l_{14H} \geq 0,60 \text{ and } l_3 / l_{3L} \geq 0,20$$

Within one layer, $(l_{14Hmax} - l_{14Hmin}) / l_{14Hmax} \leq 0,25$

Within one revolution, $(l_{14Hmax} - l_{14Hmin}) / l_{14Hmax} \leq 0,15$

31.2.3 Signal asymmetry

The signal asymmetry shall meet the following requirement:

$$-0,05 \leq \left[\frac{\frac{l_{14H} + l_{14L}}{2} - \frac{l_{3H} + l_{3L}}{2}}{l_{14}} \right] \leq +0,15$$

31.2.4 Normalized Slicing Level jump

Between any 2 consecutive ECC Blocks, the Normalized Slicing Level (NSL) jump shall be:

$$\left| \frac{(l_{3H,2} + l_{3L,2}) - (l_{3H,1} + l_{3L,1})}{(l_{3H,2} - l_{3L,2}) + (l_{3H,1} - l_{3L,1})} \right| \leq 0,50$$

where $l_{3H,1}$ and $l_{3L,1}$ are the l_3 levels just before the linking position

and $l_{3H,2}$ and $l_{3L,2}$ are the l_3 levels just after the linking position.

This requirement shall be fulfilled also when the 2 ECC Blocks have been recorded at different speeds.

31.2.5 Jitter

Jitter is the standard deviation σ of the time variations of the binary read signal. This binary read signal is created by a slicer, after feeding the HF signal from the HF read channel through an equalizer and LPF (see Annex E). The jitter of the leading and trailing edges is measured relative to the PLL clock and normalized by the Channel bit clock period.

The jitter shall be measured at the Reference velocity using the circuit specified in Annex E.

The jitter measurement shall be using the conditions specified in 30.4.

The measured jitter shall not exceed 9,0 %.

31.2.6 Track Cross signal

The Track Cross signal is the filtered sinusoidal sum signal ($I_1 + I_2$) in Read Channel 1 when the focus of the optical beam crosses the tracks (see 28.3). The Track Cross signal shall meet the following requirement:

$$\frac{(I_1 + I_2)_{pp}}{(I_1 + I_2)_{max}} \geq 0,13$$

31.3 Read stability

When read with a read power of 0,8 mW at a temperature of 55 °C, all parameters specified in 31.2.2 to 31.2.6 shall be within their specified ranges after 1 000 000 repeated reads.

NOTE Reading with the same read power at lower speeds than the reference speed might degrade the read stability.

32 Additional testing conditions

Recorded +R DL disks compliant with this +R DL Standard shall also fulfill the following basic signal specifications on both layers when measured with the Pick Up Head according to the ECMA-267 Standard.

32.1 Test environment

All conditions are the same as in 30.1 to 30.2.5. except for the following.

32.1.1 Optics

The focused optical beam used for reading data shall have the following properties:

- | | |
|--|--|
| a) Wavelength (λ) | 650 nm \pm 5 nm |
| b) Numerical aperture of the objective lens (NA) | 0,60 \pm 0,01 |
| c) The objective lens shall be compensated for spherical aberrations caused by a parallel substrate with nominal thickness (0,6 mm) and nominal refractive index (1,55). | |
| d) Wave front aberration | 0,033 \times λ rms max. |
| e) Light intensity at the rim of the pupil of the lens | 60 % to 70 % of the maximum intensity in the objective radial direction and over 90 % in the tangential direction. |
| f) Polarization of the light | Circular |

- g) Normalized detector size $100 \mu\text{m}^2 \leq S / M^2 \leq 144 \mu\text{m}^2$ where S is the total surface of the quadrant photo detector
- h) Read power $0,7 \text{ mW} \pm 0,1 \text{ mW}$
- i) Relative Intensity Noise (RIN)* of laser diode -134 dB/Hz max.

* RIN (dB/Hz) = $10 \log [(a.c. \text{ light power density} / \text{Hz}) / \text{d.c. light power}]$

32.2 Definition of signals

For the definition of the following signals see 31.2 and the underlying subclauses.

32.2.1 Modulated amplitude

$$I_{14} / I_{14H} \geq 0,60 \text{ and } I_3 / I_{14} \geq 0,20$$

Within one layer, $(I_{14Hmax} - I_{14Hmin}) / I_{14Hmax} \leq 0,33$ (with PBS)

Within one layer, $(I_{14Hmax} - I_{14Hmin}) / I_{14Hmax} \leq 0,20$ (without PBS)

Within one revolution, $(I_{14Hmax} - I_{14Hmin}) / I_{14Hmax} \leq 0,15$ (with PBS)

Within one revolution, $(I_{14Hmax} - I_{14Hmin}) / I_{14Hmax} \leq 0,10$ (without PBS)

32.2.2 Signal asymmetry

$$-0,05 \leq \left[\frac{\frac{I_{14H} + I_{14L}}{2} - \frac{I_{3H} + I_{3L}}{2}}{I_{14}} \right] \leq +0,15$$

32.2.3 Jitter

The jitter shall be measured at the Reference velocity using the circuit specified in Annex E.

The jitter measurement shall be using the conditions specified in 30.4.

The measured jitter shall not exceed 9,0 %.

32.2.4 Track Cross signal

The Track Cross signal (see 28.3) shall meet the following requirement: $\frac{(I_1 + I_2)_{pp}}{(I_1 + I_2)_{max}} \geq 0,10$

32.2.5 Differential phase tracking error signal

The output currents of the four quadrants of the split photo detector shown in Figure 44 are identified by I_a , I_b , I_c , and I_d .

The differential phase tracking error signal shall be derived from the phase differences between the sum of the currents of diagonal pairs of photo detector elements when the light beam crosses the tracks:

$$\{\text{Phase}(I_a+I_c) - \text{Phase}(I_b+I_d)\}, \text{ see Figure 45 and Annex F.}$$

The phase difference signals shall be low-pass filtered with $f_c(-3 \text{ dB})$ of 30 kHz.

This differential phase tracking error signal shall meet the following requirements (see Figure 45):

Amplitude

At the positive 0 crossing $\overline{\Delta t}/T$ shall be in the range 0,50 to 1,10 at 0,10 μm radial offset, where $\overline{\Delta t}$ is the average time difference derived from the phase differences between the sum of the currents of diagonal pairs of photo detector elements, and T is the Channel bit clock period.

Asymmetry (see Figure 45)

The asymmetry shall meet the following requirement: $\frac{|T_1 - T_2|}{|T_1 + T_2|} \leq 0,20$

where T_1 is the positive peak value of $\overline{\Delta t}/T$

and T_2 is the negative peak value of $\overline{\Delta t}/T$

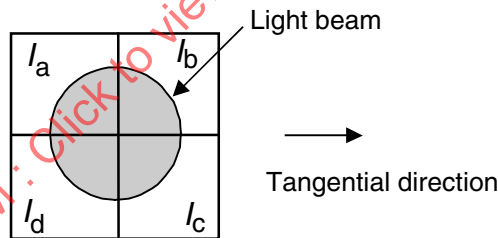

Figure 44 — Quadrant photo detector

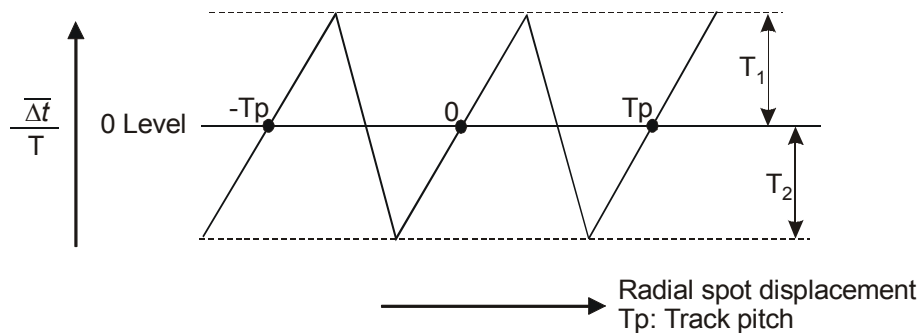

Figure 45 — Differential phase tracking error signal

32.2.6 Tangential push-pull signal

This signal shall be derived from the instantaneous level of the differential output $(I_a + I_d) - (I_b + I_c)$. It shall meet the following requirements, see Figure 46:

$$0 \leq \frac{[(I_a + I_d) - (I_b + I_c)]_{pp}}{I_{14}} \leq 0,9$$

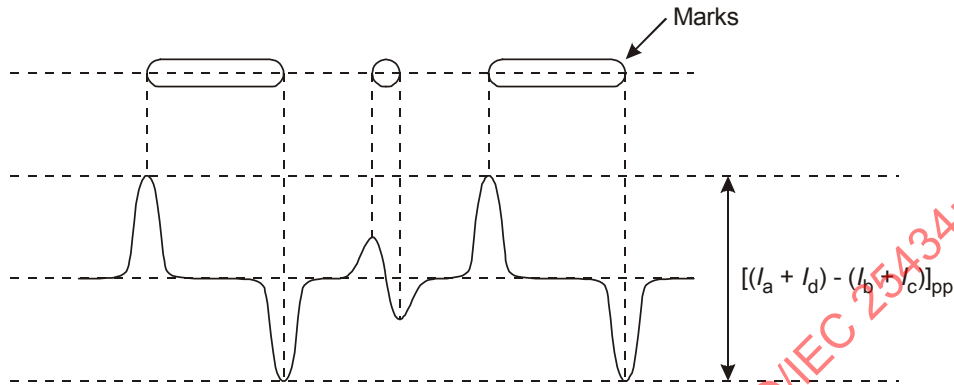

Figure 46 — Tangential push-pull signal

33 Quality of the recording layer

For the integrity of the data on the disk, the recording layers shall fulfil the following initial quality requirements.

33.1 Defects

Defects are air bubbles and black spots. Their diameter shall meet the following requirements:

- for air bubbles it shall not exceed 100 µm,
- for black spots causing birefringence it shall not exceed 200 µm,
- for black spots not causing birefringence it shall not exceed 300 µm.

In addition, over a distance of 80 mm in scanning direction of tracks, the following requirements shall be met:

- the total length of defects larger than 30 µm shall not exceed 300 µm,
- there shall be at most 6 such defects.

33.2 Data errors

A byte error occurs when one or more bits in a byte have a wrong value, as compared to their original recorded value.

A row of an ECC Block as defined in 13.3 that has at least 1 byte in error constitutes a PI error.

If a row of an ECC Block as defined in 13.3 contains more than 5 erroneous bytes, the row is said to be "PI-uncorrectable".

The disk shall be recorded with arbitrary data in one single uninterrupted writing action from the start of the Lead-in Zone until the end of the Lead-out Zone ("Disk-At-Once" mode). Both layers shall be recorded, where Layer 1 shall be recorded after recording Layer 0.

During playback after the initial recording, the errors as detected by the error correction system shall meet the following requirements:

- in any 8 consecutive ECC Blocks the total number of PI errors before correction shall not exceed 280,
- in any ECC Block the number of PI-uncorrectable rows should not exceed 4.

Section 7 - Characteristics of user data

34 Method of testing

Clause 35 describes a series of measurements to test conformance of the user data on the disk with this Standard. It checks the legibility of the user-written data. The data is assumed to be arbitrary. The data may have been written by any drive in any operating environment (see 8.1.2). The read tests shall be performed on the Reference Drive as defined in clause 9.

Whereas clause 30 disregards defects, clause 35 includes them as an unavoidable deterioration of the read signals. The severity of a defect is determined by the correctability of the ensuing errors by the error detection and correction circuit in the read channel defined below. The requirements in clause 35 define a minimum quality of the data, necessary for data interchange.

34.1 Environment

All signals in 35.1 to 35.2 shall be within their specified ranges with the disk in any environment in the range of allowed operating environments defined in 8.1.2. It is recommended that before testing, the entrance surface of the disk shall be cleaned according to the instructions of the manufacturer of the disk.

34.2 Reference Drive

All signals specified in clause 35 shall be measured in the indicated channels of the Reference Drive as defined in clause 9. The drive shall have the following characteristics for the purpose of these tests:

34.2.1 Optics and mechanics

The focused optical beam shall have the properties already defined in 9.2 a) to i). The disk shall rotate as specified in 9.5.

34.2.2 Read power

The optical power incident on the entrance surface of the disk (used for reading the information) shall be $0,7 \text{ mW} \pm 0,1 \text{ mW}$.

34.2.3 Read channels

The drive shall have two read channels. Read Channel 1 gives a signal $(I_1 + I_2)$ related to the total amount of light in the exit pupil of the objective lens. Read Channel 2 gives a signal $(I_1 - I_2)$ related to the difference in the amount of light in the two halves of the exit pupil of the objective lens. These channels can be implemented as given in 9.3 and 9.6.

The signal from Read channel 1 is equalized and filtered before processing. The threshold level for binarizing the read signal shall be controlled to minimize the effects of mark and space size changes due to parameter variations during writing. For measurement of the disk quality as specified in clause 35, the equalizer, filter and slicer, and the characteristics of the PLL shall be the same as specified in Annex E for the jitter measurement.

34.2.4 Error correction

Correction of errors in the data bytes shall be carried out by an error detection and correction system based on the definition in 13.3.

34.2.5 Tracking

During the measurement of the signals, the axial tracking error between the focus of the optical beam and the recording layer shall not exceed 0,20 μm ;

the radial tracking error between the focus of the optical beam and the centre of a track shall not exceed 0,022 μm

35 Minimum quality of a Recording Unit

This clause specifies the minimum quality of the data of a Recording Unit as required for data interchange. The quality shall be measured on the Reference Drive as defined in clause 9 and Annex E.

A byte error occurs when one or more bits in a byte have a wrong value, as detected by the ECC and/or EDC circuits.

35.1 Tracking

The focus of the optical beam shall not jump tracks unintentionally.

35.2 User-written data

The user-written data in a Recording Unit as read in Read channel 1 shall not contain any byte errors that cannot be corrected by the error correction defined in 13.3.

Annex A (normative)

80 mm +R DL disk

The +R DL Format also allows an 80 mm disk with capacities of 2,66 Gbytes and 5,32 Gbytes. All mechanical, physical and optical characteristics shall be equal to those of the 120 mm disks specified in this document, except for the following items:

see: **10.2 Overall dimensions**

The disk shall have an overall diameter $d_1 = 80,00 \text{ mm} \pm 0,30 \text{ mm}$

see: **10.7 Information Zone**

The Information Zone shall extend over both recording layers between diameter d_6 and diameter

$d_7 = 77,5 \text{ mm min.}$

see: **10.7.1 Sub-division of the Information Zone**

The end of the Data Zone on Layer 0 and the beginning of the Data Zone on Layer 1 shall be located at diameter

$d_9 = 76,00 \text{ mm max,}$

which is the beginning/end of the Middle Zones.

see: **11.1 Mass**

The mass of the disk shall be in the range of 6,0 g to 9,0 g.

see: **11.2 Moment of inertia**

The moment of inertia of the disk, relative to its rotation axis, shall not exceed 0,010 g·m².

see: **11.3 Dynamic Imbalance**

The dynamic imbalance of the disk, relative to its rotation axis, shall not exceed 1,5 g·mm.

see: **14.1 Track shape**

The tracks shall be continuous in the Information Zone. The groove tracks shall start at a radius of 22,00 mm max. and end at a radius of 38,75 mm min.

see: **14.4.1.1 ADIP word structure, bit 2 to 23**

Physical ADIP Address (033A7F), which is the last address corresponding to the Data Zone on Layer 0, shall be located at radius 38,00 mm max

Physical ADIP Address (FCC580), which is the first address corresponding to the Data Zone on Layer 1, shall be located at radius 38,00 mm max

see: 14.4.2.1 General information - Bytes 0 to 31

Byte 1 – Disk size and maximum transfer rate

Bits b7 to b4 shall specify the disk size, they shall be set to 0001, indicating a 80 mm disk

Bytes 4 to 15 – Data Zone allocation

Bytes 13 to 15 shall be set to (0CE9FF) to specify PSN 846 335 as the last possible Physical Sector of the Data Zone on Layer 0.

see: 16 Layout of the Information Zone of a Single-session disk

Table 4 — Layout of a fully recorded Layer 0 on a Single-session disk

	Description	Nominal radius in mm	PSN of the first Physical Sector	Number of Physical Sectors	
Tracking direction ↓	Inner Drive Area	all the same as 120 mm disk	---	---	
	Lead-in	all the same as 120 mm disk	---	---	
	Data	Data Zone	start 24,000 mm	(030000)	649 728 max
	Middle Zone 0	Buffer Zone 3	start 38,000 mm (at full capacity)	(0CEA00) max	768
		Reserved		(0CED00) max	256
		Guard Zone 2		(0CEE00) max	10 240 min
	Outer Drive Area	Outer Disk Administration Zone	start 38,198 mm	(0D1600)	4 096
		Outer Disk Count Zone	start 38,269 mm	(0D2600)	2 048
		Dummy Zone	start 38,305 mm	(0D2E00)	1 024
		Outer Disk Test Zone	start 38,323 mm	(0D3200)	8 192
Guard Zone 3		start 38,465 mm	(0D5200)	blank	

Table 5 — Layout of a fully recorded Layer 1 on a Single-session disk

	Description	Nominal radius in mm	PSN of the first Physical Sector	Number of Physical Sectors	
Tracking direction ↑	Inner Drive Area	all the same as 120 mm disk	---	---	
	Lead-out	all the same as 120 mm disk	---	(FD0000)	---
	Data	Data Zone	end 24,000 mm	(F31600) min	649 728 max
	Middle Zone 1	Buffer Zone 3	end 38,000 mm (at full capacity)	(F31300) min	768
		Reserved Zone		(F31200) min	256
		Guard Zone 2		(F2EA00)	10 240 min
	Outer Drive Area	Outer Disk Administration Zone	end 38,198 mm	(F2DA00)	4 096
		Outer Disk Count Zone	end 38,269 mm	(F2D200)	2 048
		Count Zone Run-in	end 38,305 mm	(F2CE00)	1 024
		Outer Disk Test Zone	end 38,323 mm	(F2AE00)	8 192
Guard Zone 3		end 38,465 mm	--	blank	

see: **17.6.1 Table of Contents Blocks**

Physical Sector 0 / bytes D₄₅ to D₄₇ – Actual last PSN of Data Zone on Layer 0

these 3 bytes shall specify the PSN of the last Physical Sector in the Data Zone on Layer 0. If not requested differently by the host/application, this address shall be set to (0CE9FF).

see: **19 Data Zone**

Two times 649 728 Physical Sectors for the storage of user data.

The start radius of the Data Zone on Layer 0 and Layer 1 is determined by the location of Physical ADIP Address (00C000) and (FCC580) respectively and the maximum/minimum end radius is determined by the location of Physical ADIP Address (033A80) and (FF4000) respectively (see 14.4.1.1, bit 2 to 23 and 13.7.1).

see: **20 Middle Zones**

	Data Zone on Layer 0	
Physical Sector 846 335 max Physical Sector 846 336 max	Buffer Zone 3 768 Physical Sectors with Main Data set to (00)	Physical Sector (0CE9FF) max Physical Sector (0CEA00) max
Physical Sector 847 103 max Physical Sector 847 104 max		Physical Sector (0CECFF) max Physical Sector (0CED00) max
Physical Sector 847 359 max Physical Sector 847 360 max	Reserved 256 Physical Sectors	Physical Sector (0CEDFF) max Physical Sector (0CEE00) max
Physical Sector 857 599 Physical Sector 857 600	Guard Zone 2 min 10 240 Physical Sectors with Main Data set to (00) (remaining sectors are allowed to be unrecorded)	Physical Sector (0D15FF) Physical Sector (0D1600)
	Outer Drive Area	

Figure 32 — Middle Zone on Layer 0

	Outer Drive Area	
Physical Sector 15 919 615 Physical Sector 15 919 616	Guard Zone 2 min 10 240 Physical Sectors with Main Data set to (00) (remaining sectors are allowed to be unrecorded)	Physical Sector (F2E9FF) Physical Sector (F2EA00)
Physical Sector 15 929 855 min Physical Sector 15 929 856 min		Physical Sector (F311FF) min Physical Sector (F31200) min
Physical Sector 15 930 111 min Physical Sector 15 930 112 min	Reserved Zone 256 Physical Sectors	Physical Sector (F312FF) min Physical Sector (F31300) min
Physical Sector 15 930 879 min Physical Sector 15 930 880 min	Buffer Zone 3 768 Physical Sectors with Main Data set to (00)	Physical Sector (F315FF) min Physical Sector (F31600) min
	Data Zone on Layer 1	

Figure 33 — Middle Zone on Layer 1

see: **20.1 Buffer Zones 3**

The outermost possible start location of Buffer Zone 3 is (0CEA00) on Layer 0 and (F31300) on Layer 1.

see: **20.4 Guard Zones 2**

These zones shall contain a minimum of 10 240 Physical Sectors filled with Main Data set to (00), adjoining the Reserved Zone.

see: 21 Outer Drive Areas

Physical Sector 857 599	Middle Zone	Physical Sector (0D15FF)
Physical Sector 857 600	Outer Disk Administration Zone	Physical Sector (0D1600)
Physical Sector 861 695	4 096 Physical Sectors	Physical Sector (0D25FF)
Physical Sector 861 696	Outer Disk Count Zone	Physical Sector (0D2600)
Physical Sector 863 743	2 048 Physical Sectors	Physical Sector (0D2DFF)
Physical Sector 863 744	Dummy Zone	Physical Sector (0D2E00)
Physical Sector 864 767	1 024 Physical Sectors	Physical Sector (0D31FF)
Physical Sector 864 768	Outer Disk Test Zone	Physical Sector (0D3200)
Physical Sector 872 959	8 192 Physical Sectors	Physical Sector (0D51FF)
Physical Sector 872 960	Guard Zone 3	Physical Sector (0D5200)
	Blank	

Figure 34 — Outer Drive Area on Layer 0

Physical Sector 15 904 255	Guard Zone 3	Physical Sector (F2ADFF)
Physical Sector 15 904 256	Blank	Physical Sector (F2AE00)
Physical Sector 15 912 447	Outer Disk Test Zone	Physical Sector (F2CDFF)
Physical Sector 15 912 448	8 192 Physical Sectors	Physical Sector (F2CE00)
Physical Sector 15 913 471	Count Zone Run-in	Physical Sector F2D1FF)
Physical Sector 15 913 472	1 024 Physical Sectors	Physical Sector (F2D200)
Physical Sector 15 915 519	Outer Disk Count Zone	Physical Sector (F2D9FF)
Physical Sector 15 915 520	2 048 Physical Sectors	Physical Sector (F2DA00)
Physical Sector 15 919 615	Outer Disk Administration Zone	Physical Sector (F2E9FF)
Physical Sector 15 919 616	4 096 Physical Sectors	Physical Sector (F2EA00)
	Middle Zone	

Figure 35 — Outer Drive Area on Layer 1

see: 21.2 Outer Disk Count Zone

2 048 Physical Sectors reserved for counting the number of OPC algorithms performed in the Outer Disk Test Zone (see Annex I).

The relation between the first Physical Sector number PSN_{ODT} of the used ECC Block in the Outer Disk Test Zone and the Physical Sector numbers PSN_{ODC} to $PSN_{ODC} + 3$ of the 4 Physical Sectors in the Outer Disk Count Zone is determined by the following mathematical expressions:

$$PSN_{ODC} = \{(PSN_{ODT}) - (0D3200)\} / (04) + (0D2600) \text{ for Layer 0, and}$$

$$PSN_{ODC} = \{(PSN_{ODT}) - (F2AE00)\} / (04) + (F2D200) \text{ for Layer 1.}$$

see: 21.4 Outer Disk Test Zone

8 192 Physical Sectors on each layer reserved for drive testing and OPC algorithms (see Annex I).

Annex B (normative)

Structure for Extended format information in the Data Zone

The ADIP Aux Frames in the Data Zone may be used to store information needed to support specific applications, such as e.g. encryption/decryption keys needed for a copy-protection system. This annex only specifies the general structure for such information.

B.1 Extended format information

The Extended Format Information consists of a table of contents (EFI TOC) and up to 16 distinct regions that contain additional format information. The EFI TOC defines the location and contents of the regions contained in the Extended Format Information, see B.1.1. The EFI TOC shall be stored in the ADIP Aux Frames (see 14.4.1.1) in the Data Zone, starting at the ADIP word that has Physical ADIP Address (00C000). The regions of the Extended Format Information shall be located in the ADIP Aux Frames in the Data Zone and/or shall be present as pre-recorded areas in the main data channel. Each region contains one or more copies of a data block of a particular type, as indicated in the EFI TOC. Each region shall be contained in one recording layer (regions shall not cross the layer jump).

Figure B.1 schematically shows an example lay-out, based on the VCPS copy-protection system, with the EFI TOC and the VCPS-defined regions that are contained in the ADIP Aux Frames in the Data Zone. The EFI TOC consists of 8 consecutive copies of an ETOC block, where each ETOC block contains the complete EFI TOC information (see B.1.1). The VCPS-defined hash region contains one or more copies of the DKB hash value, as specified in the EFI TOC. The VCPS-defined DKB region contains one or more copies of the DKB, as specified in the EFI TOC. Gaps may exist between any two regions. All bytes in the ADIP Aux Frames in the gaps shall be set to (00).

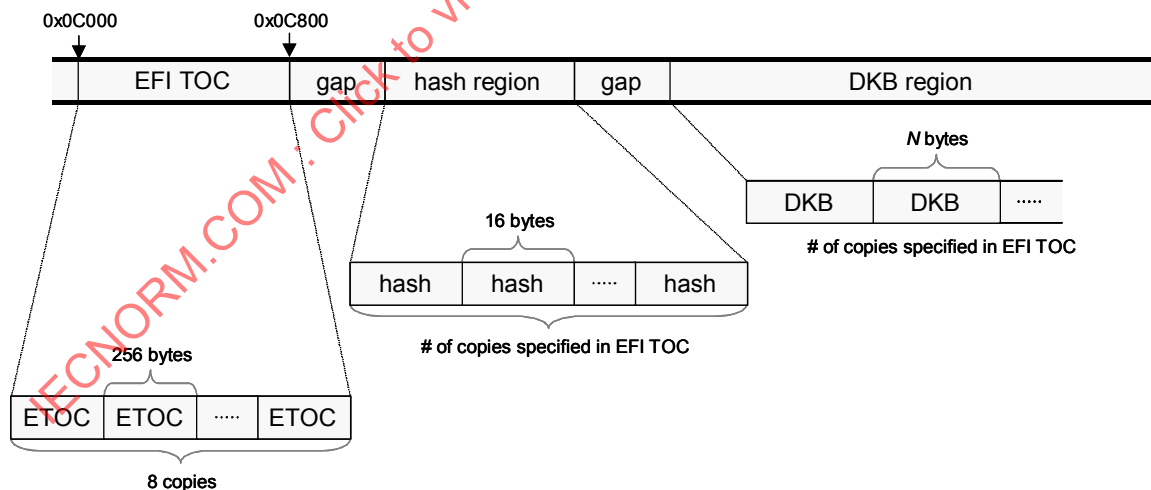

Figure B.1 — Example lay-out of Extended format information in ADIP

B.1.1 EFI TOC

The EFI TOC starts at the ADIP word that has Physical Address (00C000). The length of the EFI TOC is 8 ADIP Aux Frames, which is equivalent to 2048 consecutive ADIP words. As shown in Figure B.1, the EFI TOC consists of 8 consecutive copies of an ETOC block. The ETOC block consists of at most 16 Region Descriptors, as defined in Figure B.2. The combined size of all Region Descriptors contained in the ETOC block shall be no more than 256 bytes. Remaining bytes shall be set to all zeros, such that the size of the ETOC block is exactly 256 bytes.

Bit	7	6	5	4	3	2	1	0
0	Region Descriptor #1							
:								
:	Region Descriptor #2							
:								
:	:							
:								
:	Region Descriptor #n							
:								
:	(00)							
:								
255	(00)							

Figure B.2 — ETOC block

Region Descriptor #i: Region Descriptor #i contains information with respect to the i-th region of the Extended Format Information ($1 \leq i \leq n \leq 16$). A Region Descriptor consists of a Basic Region Descriptor followed by zero or more Extended Region Descriptors. The format of a Basic Region Descriptor is defined in Figure B.3. The format of an Extended Region Descriptor is defined in Figure B.4.

Bit	7	6	5	4	3	2	1	0
0	(msb) Region Type Identifier							
1								
2	(lsb)							
3	Extent	Version number						
4	(msb) Region Start Address							
5								
6	(msb) Data Block Size							
:								
9	(lsb)							
10	Repeat Count							
11	Reserved							Private
12	(msb) Alternative Location							
:								
15	(lsb)							

Figure B.3 — Basic Region Descriptor

Region Type Identifier: The type of the data block that is contained in the region. Data blocks stored in different regions having the same Region Type Identifier shall be identical.

Extent: The Extent bit shall indicate if this Basic Region Descriptor is followed by an Extended Region Descriptor, as follows:

- 0: This Basic Region Descriptor is not followed by an Extended Region Descriptor.
- 1: This Basic Region Descriptor is followed by an Extended Region Descriptor.

Version Number: The revision of the data block type that is contained in the region.

Region Start Address: If the data block is stored in the ADIP Aux Frames, the Region Start Address is given as the Physical ADIP Address of the ADIP word that contains the first byte of the data block, divided by 256. The Region Start Address shall be greater than or equal to (00C8). If the data block is not stored in the ADIP Aux Frames, the Region Start Address shall be zero. In that case the Alternative Location shall be non-zero and specify the location of the data block in the main data channel.

Data Block Size: The size in bytes of a single copy of the data block in the region. The Data Block Size shall be set to zero if the data block is not contained in the ADIP Aux Frames.

Repeat Count: The number of consecutive copies of the data block that are contained in the region. If the data block is stored in the ADIP Aux Frames and the region extends through the end of the Disk, Repeat Count shall be set to 0. The Repeat Count shall be set to zero if the data block is not contained in the ADIP Aux Frames.

Reserved: All reserved bits shall be set to "0".

Private: The Private bit shall indicate if a Drive is permitted to output the contents of the region, as follows:

- 0: A Drive is permitted to output the contents of the region.
- 1: A Drive is not permitted to output the contents of the region.

Alternative Location: In addition to, or alternative to storage in the ADIP Aux Frames, the data block may be stored in a contiguous area of the main data channel. In that case, the Alternative Location specifies the first Physical Sector Number of the location in the main data channel that contains one or more copies of the data block. Otherwise, Alternative Location shall be set to zero. Note that the format of the data block as contained in the main data channel may be different from the format of the data block as contained in the ADIP Aux Frames.

Byte	Bit	7	6	5	4	3	2	1	0
0		Region Type Identifier							
1									
2									
3	Extent	Version number							
4		Reserved							
:									
15									

Figure B.4 — Extended Region Descriptor

Region Type Identifier: the Region Type Identifier shall be identical to the Region Type Identifier contained in the preceding Basic Region Descriptor.

Extent: The Extent bit shall indicate if this Extended Region Descriptor is followed by another Extended Region Descriptor, as follows:

- 0: This Extended Region Descriptor is not followed by another Extended Region Descriptor.
- 1: This Extended Region Descriptor is followed by another Extended Region Descriptor.

Version Number: the Version Number shall be identical to the Version Number contained in the preceding Basic Region Descriptor.

Reserved: All reserved bytes shall be set to (00).

Annex C (normative)

Measurement of light reflectivity

C.1 Calibration method

The reflectivity of a disk can be measured in several ways. The two most common methods are:

- parallel method,
- focused method.

For use in players the focused method with the help of a reference disk with known reflectivity is the most relevant and easiest one, while for the calibration of the reference disk the parallel method is easier.

When measuring the reflectivity in the focused way, only the light returned by the reflective layer of the disk (R_m) will fall onto the photo detector. The reflected light coming from the front surface of the disk and the light coming from the parasitic reflections inside the disk will mainly fall outside the photo detector. Because in the parallel method only the "total" reflectance ($R_{//}$) can be measured, a calculation is needed to determine the "main" reflectance from the reflective layer.

A good reference disk shall be chosen, for instance 0,6 mm glass disk with a golden reflective mirror. This reference disk shall be measured by a parallel beam as shown in Figure C.1

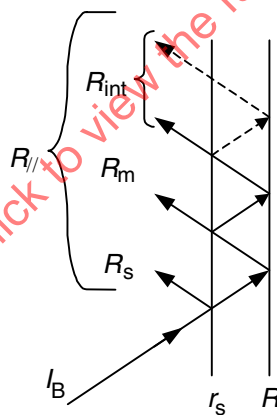

Figure C.1 — Reflectivity calibration

In this figure the following applies:

R = reflectance of the recording layer (including the double pass substrate transmittance)

r_s = reflectance of the entrance surface

R_{ref} = reflectance as measured by the focussed beam (is by definition = R_m / I_B)

I_B = incident beam

R_s = reflectance caused by the reflectivity of the entrance surface

R_m = main reflectance caused by the reflectivity of the recording layer

R_{int} = reflectance caused by the internal reflections between the entrance surface and the recording layer

$R_{//}$ = measured value ($R_s + R_m + R_{int}$)

The reflectance of the entrance surface is defined by:

$$r_s = \left(\frac{n-1}{n+1} \right)^2, \text{ where } n \text{ is the index of refraction of the substrate.}$$

The main reflectance $R_m = R_{//} - R_s - R_{int}$ which leads to:

$$R_{ref} = \frac{R_m}{I_B} = \left[\frac{(1-r_s)^2 \times \left(\frac{R_{//} - r_s}{I_B} \right)}{1-r_s \times \left(2 - \frac{R_{//}}{I_B} \right)} \right]$$

The reference disk shall be measured on a reference drive. The total detector current ($I_1 + I_2$) obtained from the reference disk, and measured by the focused beam is equated to R_m as determined above.

Now the arrangement is calibrated and the focused reflectance is a linear function of the reflectivity of the recording layer and the double pass substrate transmission, independently from the reflectivity of the entrance surface.

C.2 Measuring method

Reflectivity in the unrecorded Information Zone

A method of measuring the reflectance using the reference drive.

- (1) Measure the total detector current $(I_1 + I_2)_s$ from the reference disk with calibrated reflectance R_{ref} .
- (2) Measure the total detector current $(I_1 + I_2)_g$ from a groove track in an area of the disk under investigation where the groove track and the two adjacent tracks on each side of the track to be measured have not been recorded.
- (3) Calculate the unrecorded disk reflectance R_d as follows

$$R_d = \frac{(I_1 + I_2)_g}{(I_1 + I_2)_s} \times R_{ref}$$

Reflectivity in the recorded Information Zone

A method of measuring the reflectance using the reference drive.

- (1) Measure the total detector current $(I_1 + I_2)_s$ from the reference disk with calibrated reflectance R_{ref} .
- (2) Measure I_{14H} from a recorded groove track in an area of the disk under investigation where at least the two adjacent tracks on each side of the track to be measured have been recorded.
- (3) Calculate the recorded disk reflectance R_{14H} as follows:

$$R_{14H} = \frac{I_{14H}}{(I_1 + I_2)_s} \times R_{ref}$$

Annex D
(normative)

Measurement of birefringence

D.1 Principle of the measurement

In order to measure the birefringence, circularly polarized light in a parallel beam is used. The phase retardation is measured by observing the ellipticity of the reflected light.

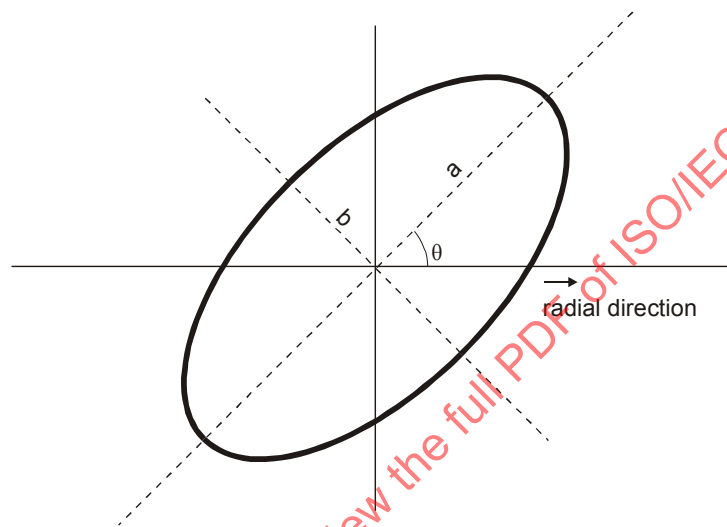

Figure D.1 — Ellipse with ellipticity $e = b/a$ and orientation θ

The orientation θ of the ellipse is determined by the orientation of the optical axis

$$\theta = \gamma - \pi/4 \tag{1}$$

where γ is the angle between the optical axis and the radial direction.

The ellipticity, $e = b/a$, is a function of the phase retardation δ

$$e = \tan \left[\frac{1}{2} \left(\frac{\pi}{2} - \delta \right) \right] \tag{2}$$

When the phase retardation δ is known the birefringence BR can be expressed as a fraction of the wavelength

$$BR = \frac{\lambda}{2\pi} \delta \, nm \tag{3}$$

Thus, by observing the elliptically polarized light reflected from the disk, the birefringence can be measured and the orientation of the optical axis can be assessed as well.

D.2 Measurements conditions

The measurement of the birefringence specified above shall be made under the following conditions.

Mode of measurement in reflection, double pass through the substrate.

Wavelength λ of the laser light	640 nm \pm 15 nm
Beam diameter (FWHM)	1,0 mm \pm 0,2 mm
Angle β of incidence in radial direction relative to the radial plane perpendicular to Reference Plane P	7,0° \pm 0,2°
Disk mounting	horizontally
Rotation	less than 1 Hz
Temperature and relative humidity	as specified in 8.1.1

D.3 Example of a measurement set-up

Whilst this Standard does not prescribe a specific device for measuring birefringence, the device shown schematically in Figure D.2 as an example, is well suited for this measurement.

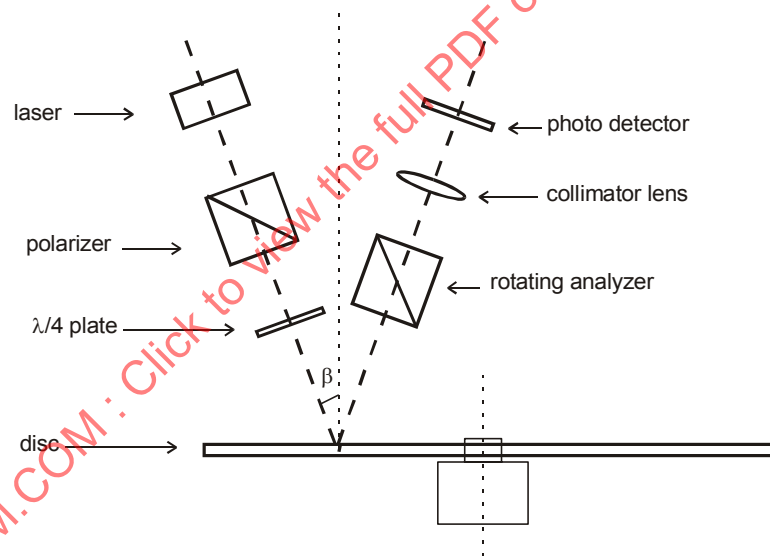

Figure D.2 — Example of a device for the measurement of birefringence

Light from a laser source, collimated into a polarizer (extinction ratio $\approx 10^{-5}$), is made circular by a $\lambda/4$ plate. The ellipticity of the reflected light is analyzed by a rotating analyzer and a photo detector. For every location on the disk, the minimum and the maximum values of the intensity are measured. The ellipticity can then be calculated as

$$e^2 = I_{\min} / I_{\max} \quad (4)$$

Combining Equations (2), (3), and (4) yields

$$BR = \frac{\lambda}{4} - \frac{\lambda}{\pi} \arctan \sqrt{\frac{I_{\min}}{I_{\max}}}$$

This device can be easily calibrated as follows

- I_{\min} is set to 0 by measuring a polarizer or a $\lambda/4$ plate,
- $I_{\min} = I_{\max}$ when measuring a mirror

Apart of the d.c. contribution of the front surface reflection, a.c. components may occur, due to the interference of the reflection(s) of the front surface with the reflection(s) from the recording layer. These a.c. reflectivity effects are significant only if the disk substrate has an extremely accurate flatness and if the light source has a high coherence.

IECNORM.COM : Click to view the full PDF of ISO/IEC 25434:2007

Annex E (normative)

Measuring conditions for operation signals

E.1 System diagram for jitter measurement and characterization of user data

The general system diagram shall be as shown in Figure E.1.

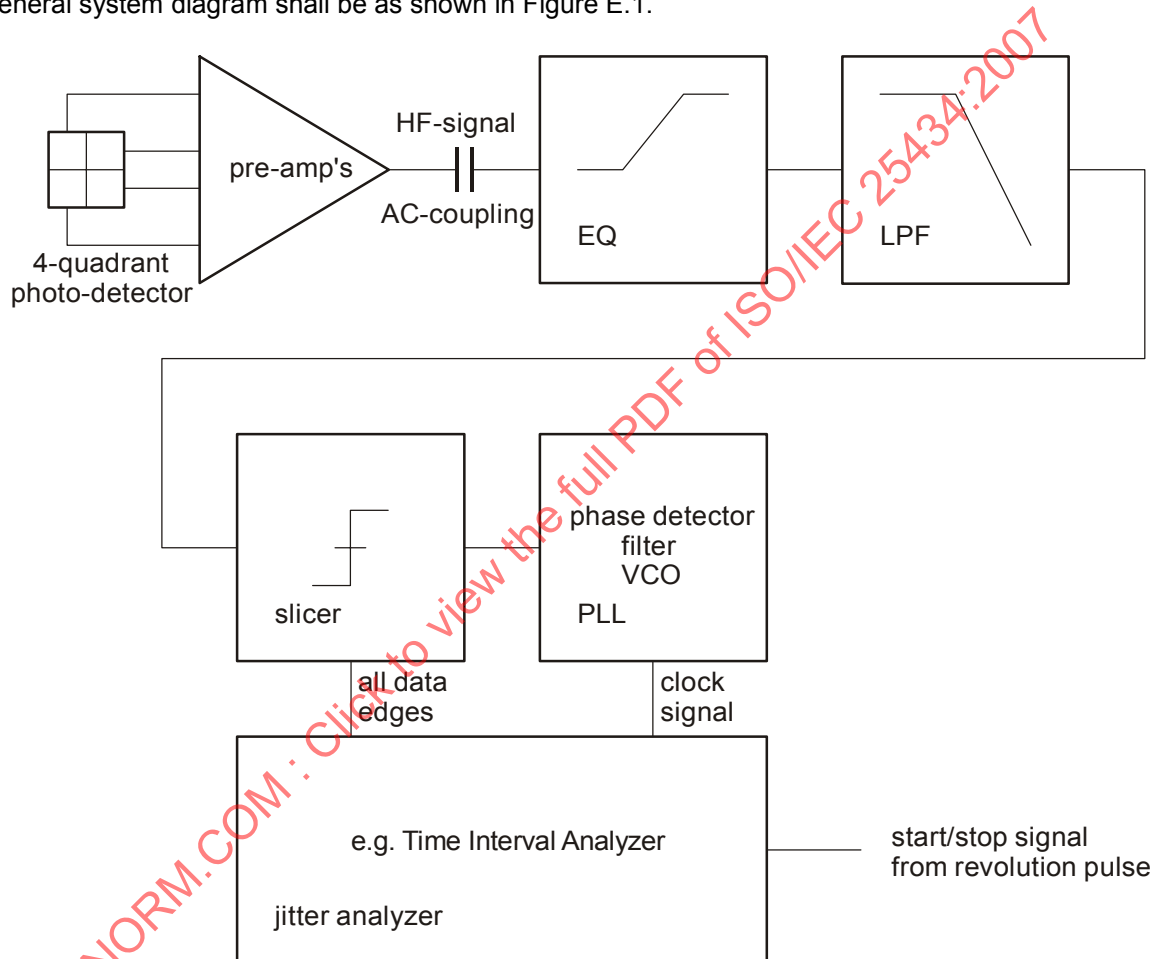

Figure E.1 — General diagram for jitter measurement

E.2 Open loop transfer function for PLL

The open-loop transfer function for the PLL shall be as shown in Figure E.2.

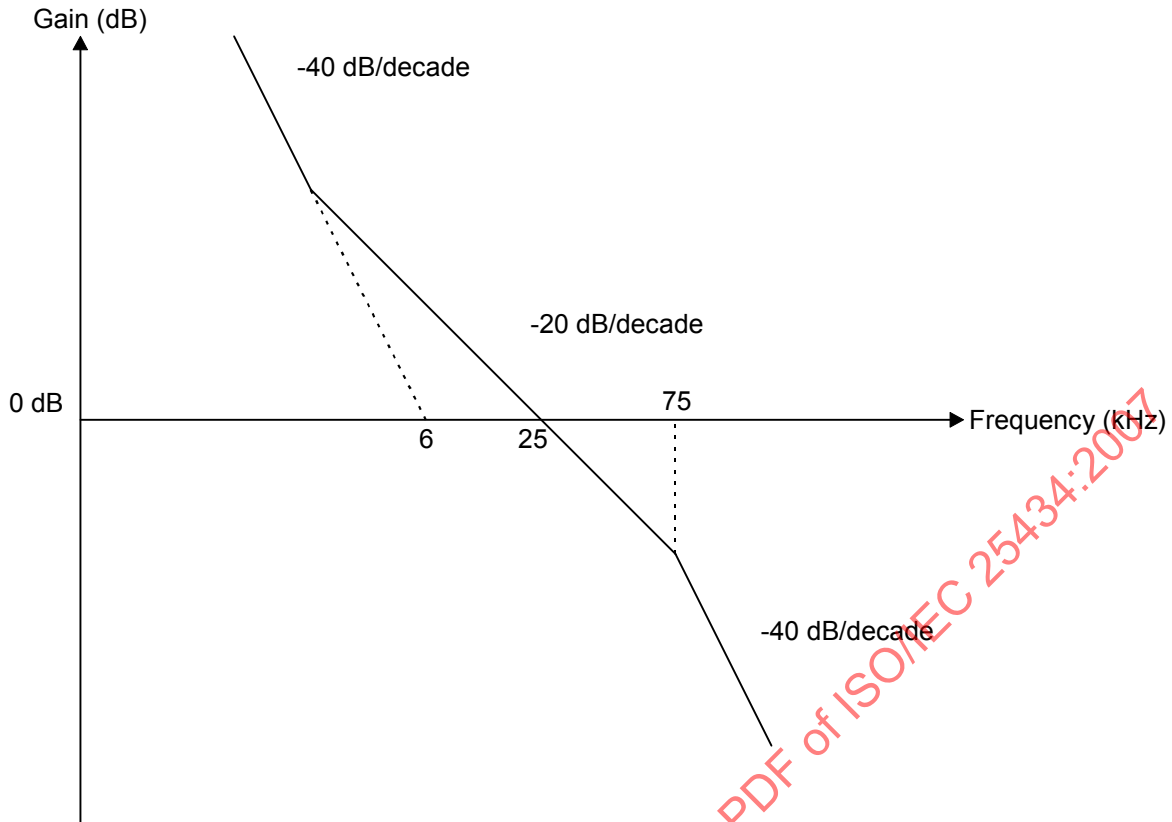

Figure E.2 — Schematic representation of the open-loop transfer function for PLL

E.3 Slicer

The slicer shall be a 1st order, integrating feed-back auto-slicer with a -3 dB closed-loop bandwidth of 5 kHz.

E.4 Conditions for measurement

The bandwidth of the pre-amplifier of the photo detector shall be greater than 20 MHz in order to prevent group-delay distortion.

Equalizer: 3-tap transversal filter with transfer function $H(z) = 1,364 z^2 - 0,182 (1 + z^4)$

Low-pass filter: 6th order Bessel filter, f_c (-3 dB) = 8,2 MHz

Filtering plus equalization:

- Gain variation: 1 dB max. (below 7 MHz)
- Group delay variation: 1 ns max. (below 7 MHz)
- (Gain at 5,0 MHz - Gain at 0 Hz) = 3,2 dB \pm 0,3 dB

a.c. coupling (high-pass filter) = 1st order, f_c (-3 dB) = 1 kHz

Correction of the angular deviation: only d.c. deviation shall be corrected.

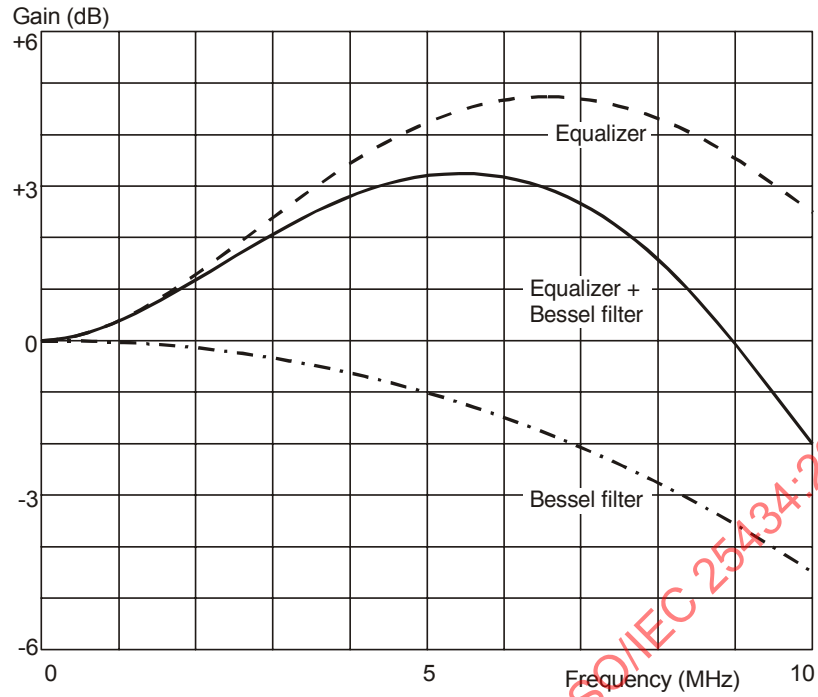

Figure E.3 — Frequency characteristics for the equalizer and the low-pass filter

E.5 Measurement

The jitter of all leading and trailing edges over one revolution shall be measured.

Annex F (normative)

Measurement of the differential phase tracking error

F.1 Measuring method for the differential phase tracking error

The reference circuit for the measurement of the tracking error shall be that shown in Figure F.1. Each output of the diagonal pairs of elements of the quadrant photo detector shall be converted to binary signals independently after equalization of the wave form with the transfer function defined by:

$$H(i\omega) = (1 + 1,6 \times 10^{-7} \times i\omega) / (1 + 4,7 \times 10^{-8} \times i\omega)$$

The gain of the comparators shall be sufficient to reach full saturation on the outputs, even with minimum signal amplitudes. Phases of the binary pulse signal edges (signals B1 and B2) shall be compared to each other to produce a time-lead signal C1 and a time-lag signal C2. The phase comparator shall react to each individual edge with signal C1 or C2, depending on the sign of Δt_i . A tracking error signal shall be produced by smoothing the C1, C2 signals with low-pass filters and by subtracting by means of a unity gain differential amplifier. The low-pass filters shall be 1st order filters with a cut-off frequency (-3 dB) of 30 kHz.

Special attention shall be given to the implementation of the circuit because very small time differences have to be measured (1 % of T equals only 0,38 ns). Careful averaging is needed.

The average time difference between two signals from the diagonal pairs of elements of the quadrant detector shall be

$$\overline{\Delta t} = \frac{1}{N} \sum \Delta t_i$$

where N is the number of edges, both rising and falling.

F.2 Measurement of $\overline{\Delta t} / T$ without time interval analyzer

The relative time difference $\overline{\Delta t} / T$ is represented by the amplitude of the tracking error signal provided that the amplitudes of the C1 and C2 signals and the frequency component of the read-out signals are normalized. The relation between the tracking error amplitude $\overline{\Delta TVE}$ and the time difference is given by:

$$\overline{\Delta TVE} = \frac{\sum \Delta t_i}{\sum T_i} V_{pc} = \frac{\sum \Delta t_i}{NnT} V_{pc} = \frac{\overline{\Delta t}}{T} \times \frac{V_{pc}}{n}$$

where:

- V_{pc} is the amplitude of the C1 and C2 signals
- T_i is the actual length of the read-out signal in the range 3T to 14T
- $n.T$ is the weighted average value of the actual lengths
- $N.n.T$ is the total averaging time.

The specification for the tracking gain can now be rewritten by using the tracking error amplitude as follows:

$$0,50 \times \left(\frac{V_{pc}}{n} \right) \leq \overline{\Delta TVE} \leq 1,10 \times \left(\frac{V_{pc}}{n} \right) \text{ at } 0,10 \mu\text{m radial offset.}$$

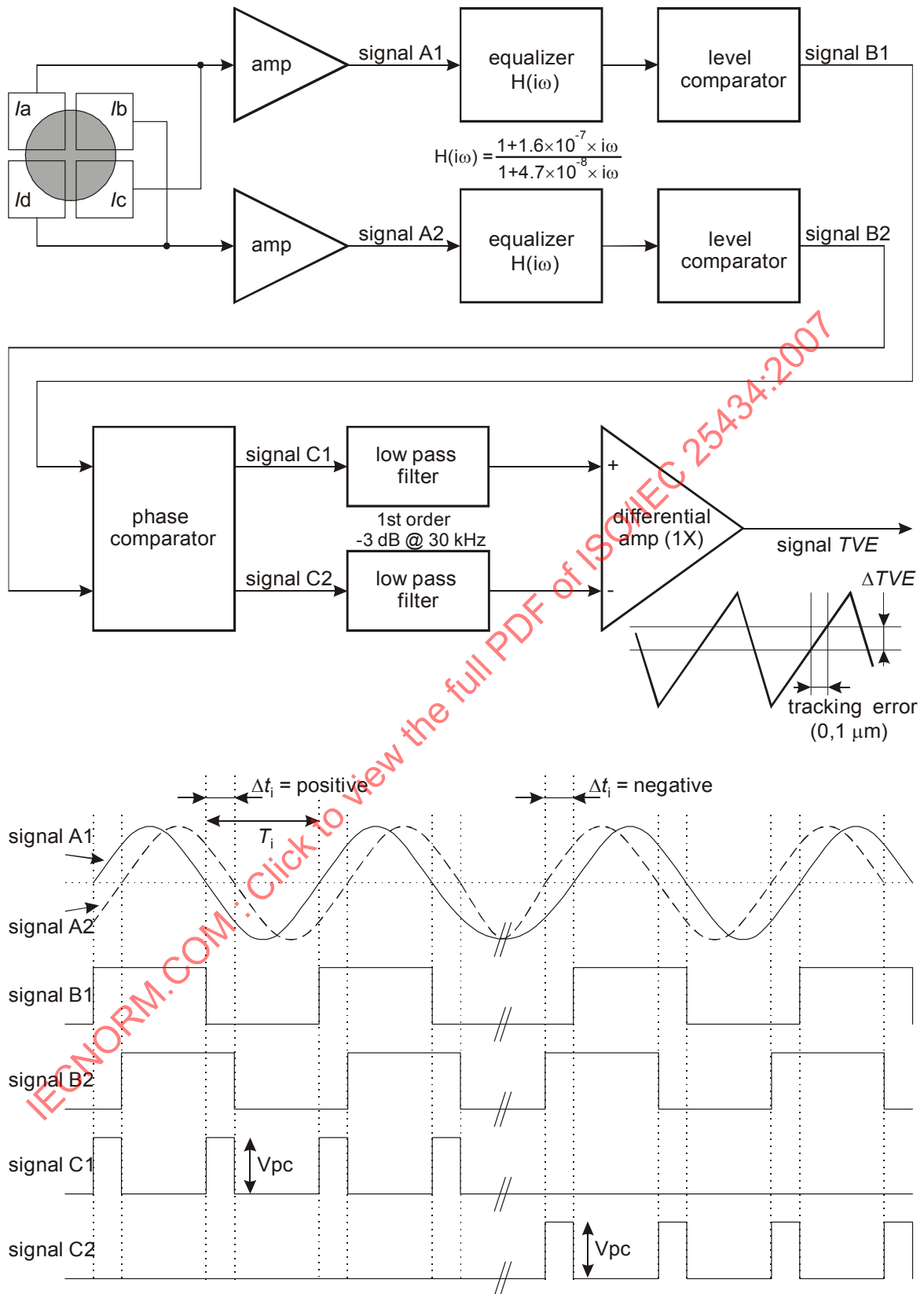

Figure F.1 — Circuit for tracking error measurements

F.3 Calibration of the circuit

Assuming that V_{pc} equals $\approx 5\text{ V}$ and that the measured value of n equals ≈ 5 , then the above relation between the tracking error amplitude $\overline{\Delta TVE}$ and the time difference $\overline{\Delta t}$ can be simplified to:

$$\overline{\Delta TVE} = \frac{\overline{\Delta t}}{T} \times \frac{V_{pc}}{n} \approx \frac{\overline{\Delta t}}{T}$$

The average runlength n of the 8-to-16 modulated signal is depending on the data content and the averaging time. Therefore the circuit shall be calibrated with a fixed frequency signal, corresponding to a modulated signal with $5T$ runlengths. For this purpose sinusoidal signals with a frequency of 2,616 MHz can be used.

Typically the pulses of signals C1 and C2 will be generated by some digital gate circuit with an output signal switching between ground and the supply voltage. This voltage swing is assumed to be about 5 volts, however, depending on the applied technology, it may deviate from 5 volts significantly.

Because the formal specification for the DPD signal is:

$$0,50 \leq \frac{\overline{\Delta t}}{T} \leq 1,10 \text{ at } 0,10 \mu\text{m radial offset,}$$

the measurement by means of $\overline{\Delta TVE}$ is influenced by the actual values of V_{pc} and n . Therefore the following calibration procedure shall be applied.

F.3.1 Saturation of comparators

Make sure that the gain of the level comparators is such that for all actual input signal levels, the signals B1 and B2 are square wave signals. In this case the amplitude of the signal TVE is independent of the amplitude of the input signals.

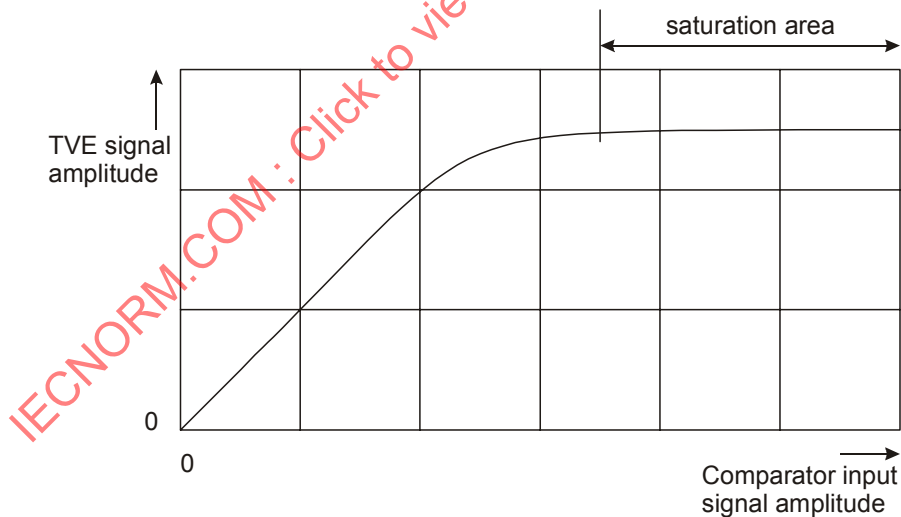

Figure F.2 — Tracking error signal amplitude versus comparator input signal amplitude

F.3.2 Correction for n and V_{pc}

Because of the above mentioned deviations of n and V_{pc} , and possibly some other circuit parameters, a correction factor K has to be determined, such that:

$$\overline{\Delta t} / T \text{ (real)} = K \times \overline{\Delta TVE} \text{ (measured).}$$

This can be achieved in the following way:

- a) Generate two sinusoidal signals A1 and A2 of frequency 2,616 MHz with a phase difference, and inject them into the two equalizer circuits.
- b) Measure the relation between $\overline{\Delta t} / T$ and $\overline{\Delta TVE}$, and determine K from Figure F.3:

$$K = \frac{\overline{\Delta t} / T (\text{injected})}{\overline{\Delta TVE} (\text{measured})}. \text{ Now the set-up is ready for use.}$$

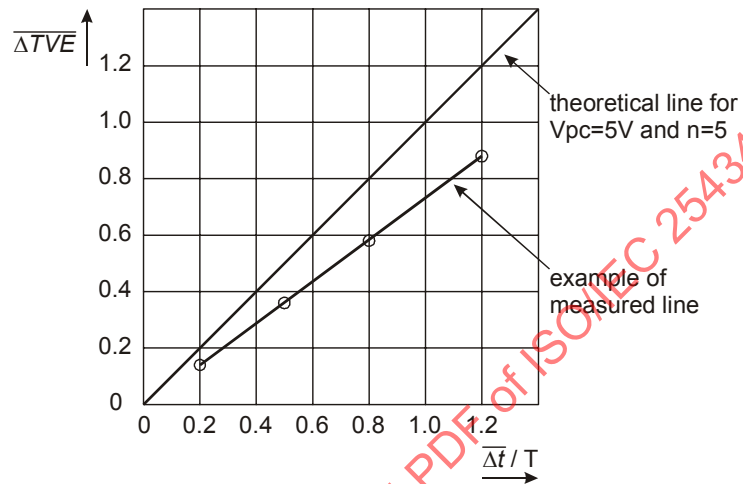

Figure F.3 — $\overline{\Delta TVE}$ versus $\overline{\Delta t} / T$

Annex G (normative)

The write pulse wave form for testing

For different speed ranges, different write strategies can be used. This version of this document specifies 2 options:

- a pulsed write strategy, where each single mark is created by a number of subsequent separated short pulses.
- a Castle write strategy, where each single mark is created by one continuous pulse with a power emphasis at the beginning and at the end of the pulse.

G.1 Pulsed write strategy

The write pulse waveform obtained from the NRZI data and the channel clock is shown in Figure G.1. It consists of $N-2$ pulses, where N is the length of the NRZI pulse expressed in channel clock cycles.

The write pulse waveform for writing marks of length $N = 3$ consists of only the top pulse (T_{top}). The write pulse waveform for writing marks of length $N \geq 4$ consist of the top pulse (T_{top}), $N-4$ multi-pulses (T_{mp}) and the last pulse (T_{lp}).

For optimum cooling down of the recording layer after writing a mark the power shall be switched to P_c between the trailing edge of the last write pulse and T_c after the trailing edge of the NRZI data pulse. P_c shall be $\leq 0,1$ mW.

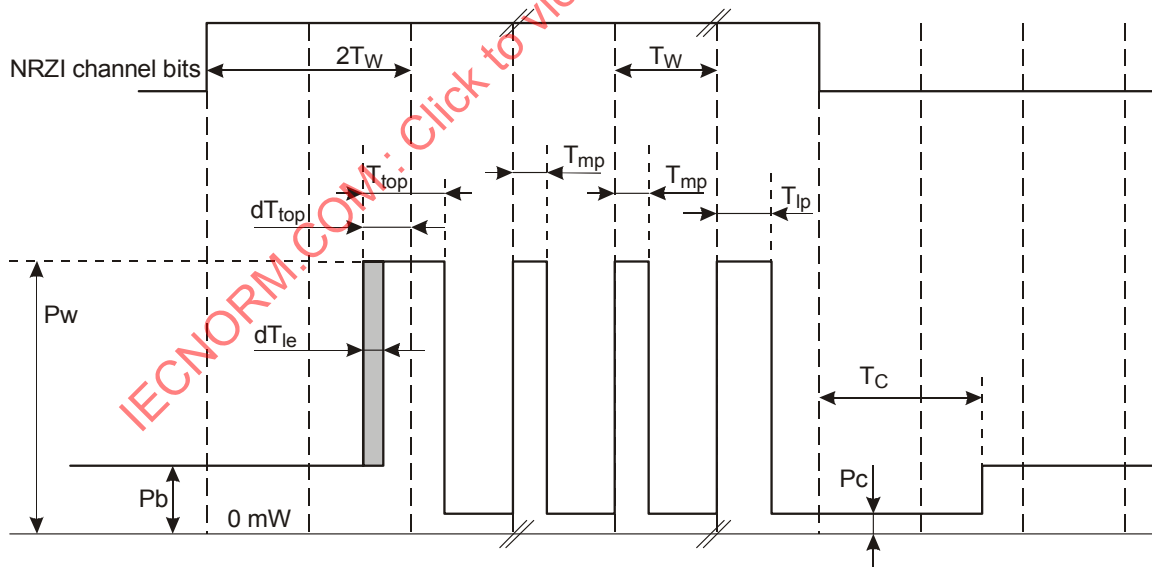

Figure G.1 — Write pulse waveform

The nominal pulse width time T_{mp} and T_{lp} shall be as indicated in the Physical format information in Table 3 and in 14.4.2.2. The duration can be dependent on the writing speed:

$$T_{mp} = m \times \frac{1}{16} T_W \quad \text{with } m = 4, 5, \dots \text{ or } 14 \quad (0,25 T_W \leq T_{mp} \leq 0,875 T_W)$$

$$T_{lp} = n \times \frac{1}{16} T_W \quad \text{with } n = 4, 5, \dots \text{ or } 24 \quad (0,25 T_W \leq T_{lp} \leq 1,5 T_W)$$

The laser power shall be switched to the cooling level between each pair of separated pulses for at least $\frac{2}{16} T_W$.

The nominal pulse width time T_{top} is dependent upon the length of the current mark (cm). It shall be as indicated in the Physical format information in Table 3 and in 14.4.2.2. The duration can also be dependent on the writing speed:

$$T_{top} (\text{cm} = 3T) = i \times \frac{1}{16} T_W \quad \text{with } i = 4, 5, \dots \text{ or } 40 \quad (0,25 T_W \leq T_{top} \leq 2,5 T_W)$$

$$T_{top} (\text{cm} \geq 4T) = j \times \frac{1}{16} T_W \quad \text{with } j = 4, 5, \dots \text{ or } 40 \quad (0,25 T_W \leq T_{top} \leq 2,5 T_W)$$

The nominal first pulse lead-time dT_{top} relative to the trailing edge of the second Channel bit of the NRZI data pulse, is dependent upon the length of the current mark (cm). It shall be as indicated in the Physical format information in Table 3 and in 14.4.2.2. The value of dT_{top} can also be dependent on the writing speed:

$$dT_{top} (\text{cm} = 3T) = p \times \frac{1}{16} T_W \quad \text{with } p = 0, 1, \dots \text{ or } 24 \quad (0,0 T_W \leq dT_{top} \leq 1,5 T_W)$$

$$dT_{top} (\text{cm} \geq 4T) = q \times \frac{1}{16} T_W \quad \text{with } q = 0, 1, \dots \text{ or } 24 \quad (0,0 T_W \leq dT_{top} \leq 1,5 T_W)$$

After the last pulse of the each pulse train representing a runlength N, the power shall be switched to the lowest possible value during a time period T_C after the trailing edge of the NRZI data pulse. T_C shall be as indicated in the Physical format information in Table 3 and in 14.4.2.2. The value of T_C can be dependent on the writing speed:

$$T_C = c \times \frac{1}{16} T_W \quad \text{with } c = 16, 17, \dots \text{ or } 32 \quad (1,0 T_W \leq T_C \leq 2,0 T_W)$$

The position of the leading edge and hence the length of the first pulse may be changed by dT_{le} dependent upon the length of the previous space (ps). This feature is called "thermal balancing". dT_{le} shall be as indicated in the Physical format information in Table 3 and in 14.4.2.2. If the previous space is ≥ 6 channel clock cycles, then dT_{le} shall be 0. The value of dT_{le} can be dependent on the writing speed:

$$dT_{le} (\text{ps} = 3T) = u \times \frac{1}{16} T_W \quad \text{with } u = 0, 1, \dots \text{ or } 4 \quad (0,0 T_W \leq dT_{le} \leq 0,25 T_W)$$

$$dT_{le} (\text{ps} = 4T) = v \times \frac{1}{16} T_W \quad \text{with } v = 0, 1, \dots \text{ or } 4 \quad (0,0 T_W \leq dT_{le} \leq 0,25 T_W)$$

$$dT_{le} (\text{ps} = 5T) = w \times \frac{1}{16} T_W \quad \text{with } w = 0, 1, \dots \text{ or } 4 \quad (0,0 T_W \leq dT_{le} \leq 0,25 T_W)$$

(dT_{le} will give a delay and reduce the length of the first pulse as indicated in Figure F.1)

NOTE The length of the cooling gap might have some influence on the position of the leading edge of the next written mark, especially in the case of a short space. Therefore some fine-tuning between dT_{le} and T_C possibly could improve the recording characteristics of the disk.

The values for P_w and P_b are determined according to the OPC algorithm (see Annex I). An example of the write pulse waveform is shown in Figure G.2.

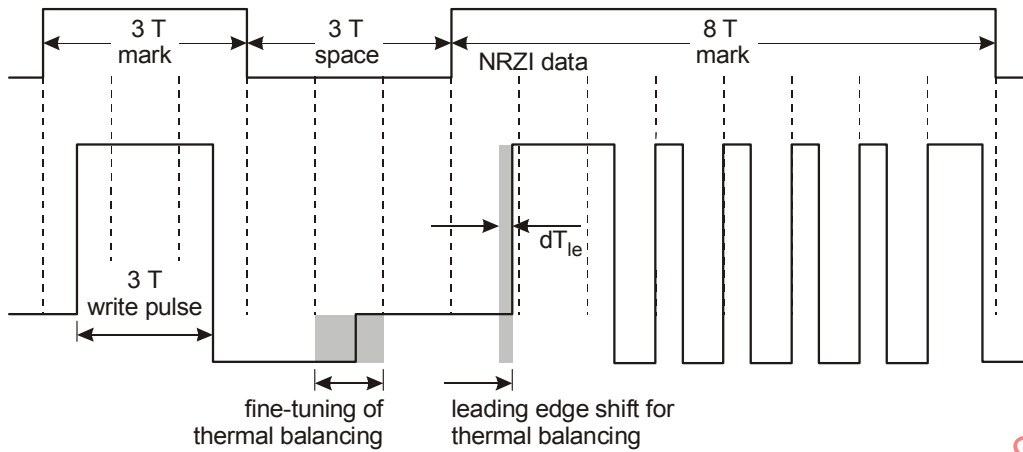

Figure G.2 — Example of a Multiple-pulse

G.2 Castle write strategy

The write pulse waveform obtained from the NRZI data and the channel clock is shown in Figure G.3. It consists of an uninterrupted pulse with a power boost at the beginning and at the end.

The write pulse waveform for writing marks of length $N = 3$ is a pulse with a length T_{I3} . The write pulse waveform for writing marks of length $N \geq 4$ is a pulse with a length $T_{I3} + (N-3) \times T_W$.

The additional power dP_w shall be applied during the whole write pulse for the 3T mark (T_{I3}) and during T_{top} and T_{end} at the beginning respectively at the end of the write pulses for the $\geq 4T$ marks. It shall be as indicated in the Physical format information in Table 5 and in 14.4.2.3.1.

$$dP_w = \frac{y}{200} \times P_w \text{ with } y = 0, 1, \dots \text{ or } 255 \text{ (} 0,00 P_w \leq dP_w \leq 1,275 P_w \text{)}$$

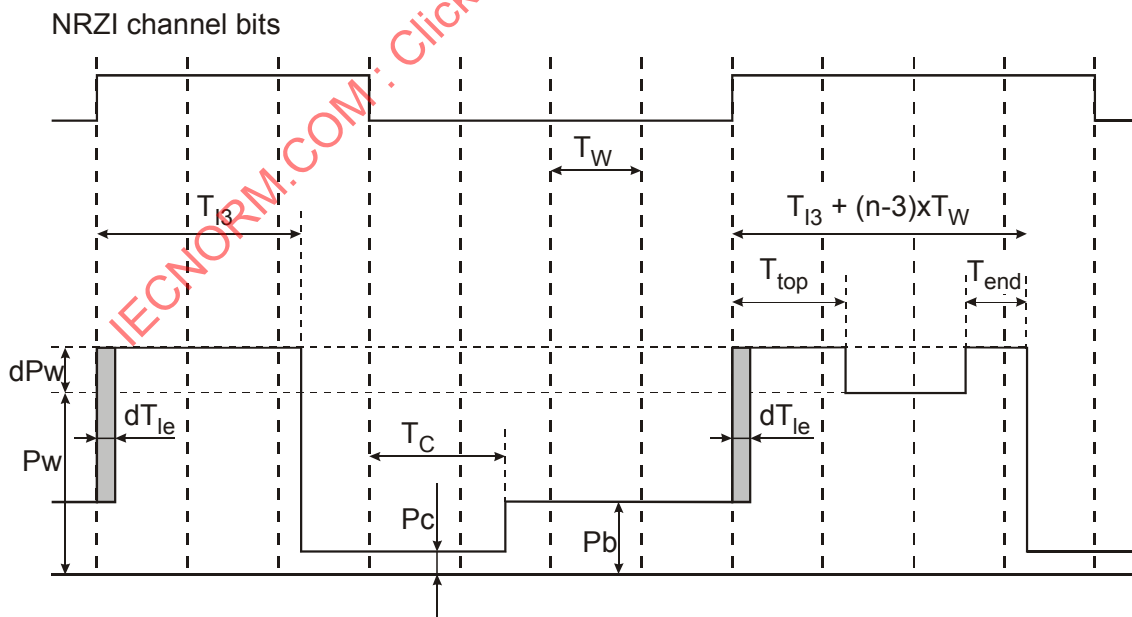

Figure G.3 — General Castle waveform

The nominal pulse width time T_{I3} shall be as indicated in the Physical format information in Table 5 and in 14.4.2.3.1. The duration can be dependent on the writing speed:

$$T_{I3} = k \times \frac{1}{16} T_W \quad \text{with } k = 16, 17, \dots \text{ or } 48 \quad (1,0 T_W \leq T_{I3} \leq 3,0 T_W)$$

The nominal pulse width time T_{top} shall be as indicated in the Physical format information in Table 5 and in 14.4.2.3.1. The duration can be dependent on the writing speed:

$$T_{top} = i \times \frac{1}{16} T_W \quad \text{with } i = 4, 5, \dots \text{ or } 32 \quad (0,25 T_W \leq T_{top} \leq 2,0 T_W)$$

The nominal pulse width time T_{end} , is dependent upon the length of the current mark (cm). It shall be as indicated in the Physical format information in Table 5 and in 14.4.2.3.1. The duration can also be dependent on the writing speed:

$$T_{end} (\text{cm} = 4T) = m \times \frac{1}{16} T_W \quad \text{with } m = 4, 5, \dots \text{ or } 32 \quad (0,25 T_W \leq T_{end} \leq 2,0 T_W)$$

$$T_{end} (\text{cm} \geq 5T) = n \times \frac{1}{16} T_W \quad \text{with } n = 4, 5, \dots \text{ or } 32 \quad (0,25 T_W \leq T_{end} \leq 2,0 T_W)$$

Because of limitations in certain implementations, the following constraints shall be kept until further notice: $T_{end} (\text{any mark}) < T_{I3}$ and $T_{I3} + (n-3) \times T_W - T_{top} - T_{end} (\text{cm} = n) \geq \frac{4}{16} T_W$ for each $n \geq 4$ (the power level P_W shall be kept for at least $0,25 T_W$)

At high recording speeds, optimum cooling down of the recording layer after writing a mark is needed. For this purpose the bias power shall be switched to P_c between the trailing edge of the write pulse and T_C after the trailing edge of the NRZI data pulse. P_c shall be $< 0,1 \text{ mW}$. T_C shall be as indicated in the Physical format information in Table 5 and in 14.4.2.3.1. The value of T_C can be dependent on the writing speed:

$$T_C = p \times \frac{1}{16} T_W \quad \text{with } p = 16, 17, \dots \text{ or } 32 \quad (1,0 T_W \leq T_C \leq 2,0 T_W)$$

The position of the leading edge and hence the start position of the pulse may be corrected by dT_{le} dependent upon the length of the previous space (ps). This feature is called "thermal balancing".

dT_{le} shall be as indicated in the Physical format information in Table 5 and in 14.4.2.3.1. If the previous space is ≥ 6 channel clock cycles, then dT_{le} shall be 0. The value of dT_{le} can be dependent on the writing speed:

$$dT_{le} (\text{ps} = 3T) = u \times \frac{1}{16} T_W \quad \text{with } u = 0, 1, \dots \text{ or } 4 \quad (0,0 T_W \leq dT_{le} \leq 0,25 T_W)$$

$$dT_{le} (\text{ps} = 4T) = v \times \frac{1}{16} T_W \quad \text{with } v = 0, 1, \dots \text{ or } 4 \quad (0,0 T_W \leq dT_{le} \leq 0,25 T_W)$$

$$dT_{le} (\text{ps} = 5T) = w \times \frac{1}{16} T_W \quad \text{with } w = 0, 1, \dots \text{ or } 4 \quad (0,0 T_W \leq dT_{le} \leq 0,25 T_W)$$

(dT_{le} will give a delay and reduce the length of the pulse as indicated in Figure G.4)

NOTE The length of the cooling gap might have some influence on the position of the leading edge of the next written mark, especially in the case of a short space. Therefore some fine-tuning between dT_{le} and T_C possibly could improve the recording characteristics of the disc.

The values for P_w , and P_b are determined according to the OPC algorithm (see Annex I). An example of the write pulse waveform is shown in figure G.4.

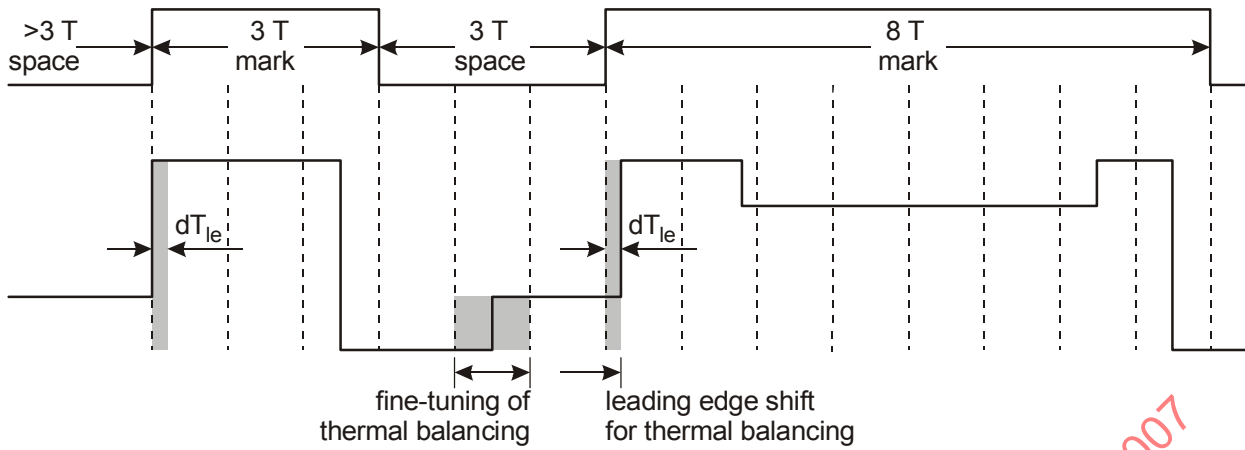

Figure G.4 — Example of a Castle waveform

G.3 Rise and fall times

The rise times, T_r , and fall times, T_f , as specified in Figure G.5 shall not exceed 2 ns for the pulsed write strategy and 1,7 ns for the Castle write strategy.

Possible overshoots shall be < 20 % of the step size P.

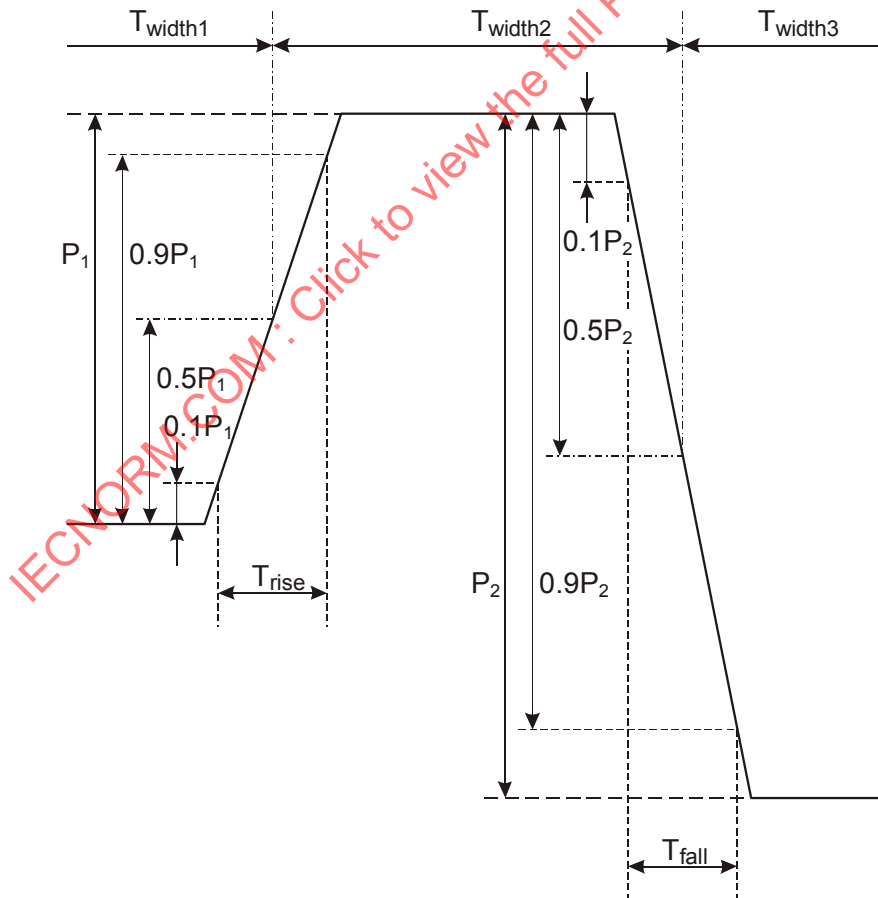

Figure G.5 — Rise Times and Fall Times