

INTERNATIONAL  
STANDARD

ISO/IEC/  
IEEE  
8802-3-2

First edition  
2021-11

---

---

**Telecommunications and exchange  
between information technology  
systems — Requirements for local and  
metropolitan area networks —**

**Part 3-2:  
Standard for Ethernet YANG data  
model definitions**

*Télécommunications et échange entre systèmes de technologies  
de l'information — Exigences relatives aux réseaux locaux et  
métropolitains —*

*Partie 3-2: Norme pour les définitions des modèles de données YANG  
Ethernet*

IECNORM.COM : Click to view the PDF file ISO/IEC/IEEE 8802-3-2:2021



Reference number  
ISO/IEC/IEEE 8802-3-2:2021(E)

© IEEE 2019

IECNORM.COM : Click to view the full PDF of ISO/IEC/IEEE 8802-3-2:2021



**COPYRIGHT PROTECTED DOCUMENT**

© IEEE 2019

All rights reserved. Unless otherwise specified, or required in the context of its implementation, no part of this publication may be reproduced or utilized otherwise in any form or by any means, electronic or mechanical, including photocopying, or posting on the internet or an intranet, without prior written permission. Permission can be requested from IEEE at the address below.

Institute of Electrical and Electronics Engineers, Inc  
3 Park Avenue, New York  
NY 10016-5997, USA

Email: [stds.ipr@ieee.org](mailto:stds.ipr@ieee.org)  
Website: [www.ieee.org](http://www.ieee.org)

Published in Switzerland

## Foreword

ISO (the International Organization for Standardization) and IEC (the International Electrotechnical Commission) form the specialized system for worldwide standardization. National bodies that are members of ISO or IEC participate in the development of International Standards through technical committees established by the respective organization to deal with particular fields of technical activity. ISO and IEC technical committees collaborate in fields of mutual interest. Other international organizations, governmental and non-governmental, in liaison with ISO and IEC, also take part in the work.

The procedures used to develop this document and those intended for its further maintenance are described in the ISO/IEC Directives, Part 1. In particular, the different approval criteria needed for the different types of ISO/IEC documents should be noted (see [www.iso.org/directives](http://www.iso.org/directives) or [www.iec.ch/members\\_experts/refdocs](http://www.iec.ch/members_experts/refdocs)).

IEEE Standards documents are developed within the IEEE Societies and the Standards Coordinating Committees of the IEEE Standards Association (IEEE-SA) Standards Board. The IEEE develops its standards through a consensus development process, approved by the American National Standards Institute, which brings together volunteers representing varied viewpoints and interests to achieve the final product. Volunteers are not necessarily members of the Institute and serve without compensation. While the IEEE administers the process and establishes rules to promote fairness in the consensus development process, the IEEE does not independently evaluate, test, or verify the accuracy of any of the information contained in its standards.

Attention is drawn to the possibility that some of the elements of this document may be the subject of patent rights. ISO and IEC shall not be held responsible for identifying any or all such patent rights. Details of any patent rights identified during the development of the document will be in the Introduction and/or on the ISO list of patent declarations received (see [www.iso.org/patents](http://www.iso.org/patents)) or the IEC list of patent declarations received (see [patents.iec.ch](http://patents.iec.ch)).

Any trade name used in this document is information given for the convenience of users and does not constitute an endorsement.

For an explanation of the voluntary nature of standards, the meaning of ISO specific terms and expressions related to conformity assessment, as well as information about ISO's adherence to the World Trade Organization (WTO) principles in the Technical Barriers to Trade (TBT), see [www.iso.org/iso/foreword.html](http://www.iso.org/iso/foreword.html). In the IEC, see [www.iec.ch/understanding-standards](http://www.iec.ch/understanding-standards).

ISO/IEC/IEEE 8802-3-2 was prepared by the LAN/MAN of the IEEE Computer Society (as IEEE Std 802.3.2-2019) and drafted in accordance with its editorial rules. It was adopted, under the "fast-track procedure" defined in the Partner Standards Development Organization cooperation agreement between ISO and IEEE, by Joint Technical Committee ISO/IEC JTC 1, *Information technology*, Subcommittee SC 6, *Telecommunications and information exchange between systems*.

A list of all parts in the ISO/IEC/IEEE 8802 series can be found on the ISO and IEC websites.

Any feedback or questions on this document should be directed to the user's national standards body. A complete listing of these bodies can be found at [www.iso.org/members.html](http://www.iso.org/members.html) and [www.iec.ch/national-committees](http://www.iec.ch/national-committees).

**Abstract:** YANG models for IEEE Std 802.3 are defined in this standard. This standard also publishes these models in a machine-readable format.

**Keywords:** 802.3, 802.3.2, Ethernet, YANG

---

The Institute of Electrical and Electronics Engineers, Inc.  
3 Park Avenue, New York, NY 10016-5997, USA

Copyright © 2019 by the Institute of Electrical and Electronics Engineers, Inc.  
All rights reserved. Published 21 June 2019. Printed in the United States of America.

IEEE and 802 are registered trademarks in the U.S. Patent & Trademark Office, owned by the Institute of Electrical and Electronics Engineers, Incorporated.

PDF: ISBN 978-1-5044-5671-5 STD23620  
Print: ISBN 978-1-5044-5672-2 STDPD23620

*IEEE prohibits discrimination, harassment and bullying. For more information, visit <http://www.ieee.org/web/aboutus/whatis/policies/p9-26.html>.*

*No part of this publication may be reproduced in any form, in an electronic retrieval system or otherwise, without the prior written permission of the publisher.*

## Important Notices and Disclaimers Concerning IEEE Standards Documents

IEEE documents are made available for use subject to important notices and legal disclaimers. These notices and disclaimers, or a reference to this page, appear in all standards and may be found under the heading “Important Notice” or “Important Notices and Disclaimers Concerning IEEE Standards Documents.”

### Notice and Disclaimer of Liability Concerning the Use of IEEE Standards Documents

IEEE Standards documents (standards, recommended practices, and guides), both full-use and trial-use, are developed within IEEE Societies and the Standards Coordinating Committees of the IEEE Standards Association (“IEEE-SA”) Standards Board. IEEE (“the Institute”) develops its standards through a consensus development process, approved by the American National Standards Institute (“ANSI”), which brings together volunteers representing varied viewpoints and interests to achieve the final product. Volunteers are not necessarily members of the Institute and participate without compensation from IEEE. While IEEE administers the process and establishes rules to promote fairness in the consensus development process, IEEE does not independently evaluate, test, or verify the accuracy of any of the information or the soundness of any judgments contained in its standards.

IEEE does not warrant or represent the accuracy or content of the material contained in its standards, and expressly disclaims all warranties (express, implied and statutory) not included in this or any other document relating to the standard, including, but not limited to, the warranties of: merchantability; fitness for a particular purpose; non-infringement; and quality, accuracy, effectiveness, currency, or completeness of material. In addition, IEEE disclaims any and all conditions relating to: results; and workmanlike effort. IEEE standards documents are supplied “AS IS” and “WITH ALL FAULTS.”

Use of an IEEE standard is wholly voluntary. The existence of an IEEE standard does not imply that there are no other ways to produce, test, measure, purchase, market, or provide other goods and services related to the scope of the IEEE standard. Furthermore, the viewpoint expressed at the time a standard is approved and issued is subject to change brought about through developments in the state of the art and comments received from users of the standard.

In publishing and making its standards available, IEEE is not suggesting or rendering professional or other services for, or on behalf of, any person or entity nor is IEEE undertaking to perform any duty owed by any other person or entity to another. Any person utilizing any IEEE Standards document, should rely upon his or her own independent judgment in the exercise of reasonable care in any given circumstances or, as appropriate, seek the advice of a competent professional in determining the appropriateness of a given IEEE standard.

IN NO EVENT SHALL IEEE BE LIABLE FOR ANY DIRECT, INDIRECT, INCIDENTAL, SPECIAL, EXEMPLARY, OR CONSEQUENTIAL DAMAGES (INCLUDING, BUT NOT LIMITED TO: PROCUREMENT OF SUBSTITUTE GOODS OR SERVICES; LOSS OF USE, DATA, OR PROFITS; OR BUSINESS INTERRUPTION) HOWEVER CAUSED AND ON ANY THEORY OF LIABILITY, WHETHER IN CONTRACT, STRICT LIABILITY, OR TORT (INCLUDING NEGLIGENCE OR OTHERWISE) ARISING IN ANY WAY OUT OF THE PUBLICATION, USE OF, OR RELIANCE UPON ANY STANDARD, EVEN IF ADVISED OF THE POSSIBILITY OF SUCH DAMAGE AND REGARDLESS OF WHETHER SUCH DAMAGE WAS FORESEEABLE.

### Translations

The IEEE consensus development process involves the review of documents in English only. In the event that an IEEE standard is translated, only the English version published by IEEE should be considered the approved IEEE standard.

## Official statements

A statement, written or oral, that is not processed in accordance with the IEEE-SA Standards Board Operations Manual shall not be considered or inferred to be the official position of IEEE or any of its committees and shall not be considered to be, or be relied upon as, a formal position of IEEE. At lectures, symposia, seminars, or educational courses, an individual presenting information on IEEE standards shall make it clear that his or her views should be considered the personal views of that individual rather than the formal position of IEEE.

## Comments on standards

Comments for revision of IEEE Standards documents are welcome from any interested party, regardless of membership affiliation with IEEE. However, IEEE does not provide consulting information or advice pertaining to IEEE Standards documents. Suggestions for changes in documents should be in the form of a proposed change of text, together with appropriate supporting comments. Since IEEE standards represent a consensus of concerned interests, it is important that any responses to comments and questions also receive the concurrence of a balance of interests. For this reason, IEEE and the members of its societies and Standards Coordinating Committees are not able to provide an instant response to comments or questions except in those cases where the matter has previously been addressed. For the same reason, IEEE does not respond to interpretation requests. Any person who would like to participate in revisions to an IEEE standard is welcome to join the relevant IEEE working group.

Comments on standards should be submitted to the following address:

Secretary, IEEE-SA Standards Board  
445 Hoes Lane  
Piscataway, NJ 08854 USA

## Laws and regulations

Users of IEEE Standards documents should consult all applicable laws and regulations. Compliance with the provisions of any IEEE Standards document does not imply compliance to any applicable regulatory requirements. Implementers of the standard are responsible for observing or referring to the applicable regulatory requirements. IEEE does not, by the publication of its standards, intend to urge action that is not in compliance with applicable laws, and these documents may not be construed as doing so.

## Copyrights

IEEE draft and approved standards are copyrighted by IEEE under U.S. and international copyright laws. They are made available by IEEE and are adopted for a wide variety of both public and private uses. These include both use, by reference, in laws and regulations, and use in private self-regulation, standardization, and the promotion of engineering practices and methods. By making these documents available for use and adoption by public authorities and private users, IEEE does not waive any rights in copyright to the documents.

## Photocopies

Subject to payment of the appropriate fee, IEEE will grant users a limited, non-exclusive license to photocopy portions of any individual standard for company or organizational internal use or individual, non-commercial use only. To arrange for payment of licensing fees, please contact Copyright Clearance Center, Customer Service, 222 Rosewood Drive, Danvers, MA 01923 USA; +1 978 750 8400. Permission to

photocopy portions of any individual standard for educational classroom use can also be obtained through the Copyright Clearance Center.

### Updating of IEEE Standards documents

Users of IEEE Standards documents should be aware that these documents may be superseded at any time by the issuance of new editions or may be amended from time to time through the issuance of amendments, corrigenda, or errata. An official IEEE document at any point in time consists of the current edition of the document together with any amendments, corrigenda, or errata then in effect.

Every IEEE standard is subjected to review at least every ten years. When a document is more than ten years old and has not undergone a revision process, it is reasonable to conclude that its contents, although still of some value, do not wholly reflect the present state of the art. Users are cautioned to check to determine that they have the latest edition of any IEEE standard.

In order to determine whether a given document is the current edition and whether it has been amended through the issuance of amendments, corrigenda, or errata, visit the IEEE-SA Website at <http://ieeexplore.ieee.org/xpl/standards.jsp> or contact IEEE at the address listed previously. For more information about the IEEE SA or IEEE's standards development process, visit the IEEE-SA Website at <http://standards.ieee.org>.

### Errata

Errata, if any, for all IEEE standards can be accessed on the IEEE-SA Website at the following URL: <http://standards.ieee.org/findstds/errata/index.html>. Users are encouraged to check this URL for errata periodically.

### Patents

Attention is called to the possibility that implementation of this standard may require use of subject matter covered by patent rights. By publication of this standard, no position is taken by the IEEE with respect to the existence or validity of any patent rights in connection therewith. If a patent holder or patent applicant has filed a statement of assurance via an Accepted Letter of Assurance, then the statement is listed on the IEEE-SA Website at <http://standards.ieee.org/about/sasb/patcom/patents.html>. Letters of Assurance may indicate whether the Submitter is willing or unwilling to grant licenses under patent rights without compensation or under reasonable rates, with reasonable terms and conditions that are demonstrably free of any unfair discrimination to applicants desiring to obtain such licenses.

Essential Patent Claims may exist for which a Letter of Assurance has not been received. The IEEE is not responsible for identifying Essential Patent Claims for which a license may be required, for conducting inquiries into the legal validity or scope of Patents Claims, or determining whether any licensing terms or conditions provided in connection with submission of a Letter of Assurance, if any, or in any licensing agreements are reasonable or non-discriminatory. Users of this standard are expressly advised that determination of the validity of any patent rights, and the risk of infringement of such rights, is entirely their own responsibility. Further information may be obtained from the IEEE Standards Association.

## Participants

The following individuals were officers and members of the IEEE 802.3 working group at the beginning of the IEEE P802.3.2 (IEEE 802.3cf) working group ballot. Individuals may have not voted, voted for approval, disapproval or abstained on this standard.

**David J. Law**, *IEEE 802.3 Working Group Chair*  
**Adam Healey**, *IEEE 802.3 Working Group Vice-Chair*  
**Pete Anslow**, *IEEE 802.3 Working Group Secretary*  
**Steven B. Carlson**, *IEEE 802.3 Working Group Executive Secretary*  
**Valerie Maguire**, *IEEE 802.3 Working Group Treasurer*

**Yan Zhuang**, *IEEE P802.3.2 (IEEE 802.3cf) YANG Data Model Definitions Task Force Chair*

**Marek Hajduczenia**, *IEEE P802.3.2 (IEEE 802.3cf) YANG Data Model Definitions Task Force Editor-in-Chief*

David Abramson	Estes David	Kimber Mark
Dale Amason	John Ewen	Klaus Andrew
Ali Angha	Ramin Farjad	Michael Klempa
Eric Baden	Shahar Feldman	Curtis Knittle
Amrik Bains	Alan Flatman	Elizabeth Kochuparambil
Thananya Baldwin	Brian Franchuk	Paul Kolesar
Denis Beaudoin	Matthias Fritsche	Hans Lackner
Piergiorgio Beruto	Richard Frosch	Jeffrey Lapak
Mark Bohm	Mike Gardner	Mark Laubach
Brad Booth	Ali Ghiasi	Greg Le Cheminant
Martin Bouda	Joel Goergen	Han Hyub Lee
David Brandt	Steven Gorshe	Hanan Leizerovich
Ralf-Peter Braun	Jens Gottron	David Lewis
Theodore Brillhart	Steffen Graber	Jon Lewis
Paul Brooks	Olaf Grau	Mike Peng Li
Matthew Brown	Robert M. Grow	Jane Lim
Phillip Brownlee	Yong Guo	Alex Lin
Chris Bullock	Mark Gustlin	Robert Lingle
Jairo Bustos Heredia	Tomohiro Hashimoto	Dekun Liu
Adrian Butter	Akinori Hayakawa	Hai-Feng Liu
Clark Carty	Rajmohan Hegde	Zhenyu Liu
Craig Chabot	David Hess	Miklos Lukacs
Mandeep Chadda	Yasuo Hidaka	Kent Lusted
David Chalupsky	David Hognlund	Zahy Madgar
Frank Chang	Rita Horner	Jeffery Maki
Xin Chang	Bernd Hormmeyer	David Malicoat
Chan Chen	Xi Huang	Arthur Marris
Weiyang Cheng	Yasuhiro Hyakutake	Takeo Masuda
Golam Choudhury	Jonathan Ingham	Kirsten Matheus
Keng Hua Chuang	Kazuhiko Ishibe	Erdem Matoglu
Keith Conroy	Hideki Isono	Mick McCarthy
John D'Ambrosia	Tom Issenhuth	Brett McClellan
Yair Darshan	Kenneth Jackson	Thomas Mcdermott
Piers Dawe	Andrew Jimenez	Larry McMillan
Fred Dawson	John Johnson	Greg McSorley
Eric DiBiaso	Chad Jones	Marcel Medina
Chris Diminico	Peter Jones	Richard Mei
Mike Dudek	Upen Kareti	Richard Mellitz
Frank Effenberger	Yasuaki Kawatsu	Phil Miguelez
Eitel Cornelia	Yong Kim	Harald Mueller
		Ron Muir

Henry Muysshondt	Laura Schweitz	Alexander Umnov
Edward Nakamoto	Masood Shariff	Sterling A. Vaden
Gary Nicholl	Ramin Shirani	Paul Vanderlaan
Kevin Noll	Mizuki Shirao	Dylan Walker
Ronald Nordin	Kapil Shrikhande	Edward Walter
Mark Nowell	Jeff Slavick	Haifei Wang
David Ofelt	Daniel Smith	Roy Wang
Tom Palkert	Scott Sommers	Tongtong Wang
Sujan Pandey	Bryan Sparrowhawk	Xinyuan Wang
Earl Parsons	Edward Sprague	Christoph Wechsler
Harsh Patel	Atul Srivastava	Brian Welch
Arkadiy Peker	Peter Stassar	Matthias Wendt
Wanquan Peng	Heath Stewart	Oded Wertheim
Gerald Pepper	David Stover	Natalie Wienckowski
Michael Peters	Junqing Sun	Ludwig Winkel
Phong Pham	Steve Swanson	Peter Wu
Jean Picard	Andre Szczepanek	Markus Wucher
David Piehler	Bharat Tailor	Dayin Xu
Rick Pimpinella	Tomoo Takahara	Yu Xu
William Powell	Kohichi Tamura	Adrian Young
Rick Rabinovich	Ronald Tellas	Lennart Yseboodt
Adee Ran	Geoffrey O. Thompson	Andrew Zambell
Alon Regev	Pirooz Tooyserkani	Conrad Zerna
Duane Remein	Nathan Tracy	Huanlin Zhang
Michael Ressler	Matthew Traverso	Qiwen Zhong
Salvatore Rotolo	David Tremblay	Martin Zielinski
Sam Sambasivan	Stephen Trowbridge	George Zimmerman
Edward Sayre	Ed Ulrichs	Helge Zinner
Fred Schindler	Daisuke Umeda	Pavel Zivny

The following members of the individual balloting committee voted on this standard. Balloters may have voted for approval, disapproval, or abstention.

Andrea Agnes	Atsushi Ito	Maximilian Riegel
Richard Alfvin	Raj Jain	Robert Robinson
Niranth Amogh	SangKwon Jeong	Benjamin Rolfe
Peter Anslow	Stuart Kerry	Daniel Smith
Butch Anton	Yongbum Kim	Thomas Starai
Ralf-Peter Braun	Patrick Kinney	Peter Stassar
Nancy Bravin	Mark Laubach	Walter Struppler
Theodore Brillhart	David J. Law	Ganesh Subramanian
Matthew Brown	Hyeong Ho Lee	Mitsutoshi Sugawara
Demetrio Bucaneg	Jon Lewis	Kohichi Tamura
Jairo Bustos Heredia	Elvis Maculuba	David Tremblay
William Byrd	Valerie Maguire	Stephen Trowbridge
Steven Carlson	Jeffery Maki	Mark-Rene Uchida
Keith Chow	Vinayagam Mariappan	Alexander Umnov
Rodney Cummings	Roger Marks	Dmitri Varsanofiev
Andrew Fieldsend	Arthur Marris	George Vlantis
Avraham Freedman	Michael Maytum	Khurram Waheed
Matthias Fritsche	Brett McClellan	Karl Weber
Yukihiro Fujimoto	Thomas Mcdermott	Hung-Yu Wei
Eric W. Gray	Richard Mellitz	Scott Willy
Randall Groves	Nick S.A. Nikjoo	Adrian Young
Robert M. Grow	Satoshi Obara	James Young
Marek Hajduczenia	Bansi Patel	Oren Yuen
Adam Healey	Rick Pimpinella	Zhen Zhou
Marco Hernandez	William Powell	Yan Zhuang
Werner Hoelzl	R. K. Rannow	Pavel Zivny
Noriyuki Ikeuchi	Alon Regev	
Sergiu Iordanescu	Duane Remein	

When the IEEE-SA Standards Board approved this standard on 21 March 2019, it had the following membership:

**Gary Hoffman**, *Chair*  
**Ted Burse**, *Vice Chair*  
**Jean-Philippe Faure**, *Past Chair*  
**Konstantinos Karachalios**, *Secretary*

Masayuki Ariyoshi  
Stephen D. Dukes  
J. Travis Griffith  
Guido Hiertz  
Christel Hunter  
Thomas Koshy  
Joseph L. Koepfinger\*  
Thomas Koshy

John D. Kulick  
David J. Law  
Joseph Levy  
Howard Li  
Xiaohui Liu  
Kevin Lu  
Daleep Mohla  
Andrew Myles  
Annette D. Reilly

Dorothy Stanley  
Sha Wei  
Phil Wennblom  
Philip Winston  
Howard Wolfman  
Feng Wu  
Jingyi Zhou

\*Member Emeritus

IECNORM.COM : Click to view the full PDF of ISO/IEC/IEEE 8802-3-2:2021

## Introduction

This introduction is not part of IEEE Std 802.3.2-2019, IEEE Standard for Ethernet YANG Data Model Definitions.

The YANG modules included in this standard provide YANG versions of attributes defined in IEEE Std 802.3<sup>TM</sup>-2018, Clause 30, as well as derivative attributes defined in other management information bases (e.g., SNMP attributes included in IEEE Std 802.3.1, YANG versions of IETF Etherlike MIB attributes, etc.). The YANG modules defined in this standard accommodate IEEE Std 802.3-2018, excluding any currently published or future amendments. As IEEE Std 802.3 continues to evolve, new revisions of this standard may be published in the future to address new technologies and features.

IECNORM.COM : Click to view the full PDF of ISO/IEC/IEEE 8802-3-2:2021

## Contents

1. Overview.....	12
1.1 Scope.....	12
1.2 Purpose.....	12
1.3 Machine-readable YANG modules .....	12
1.4 Summary of YANG-based management framework.....	12
1.5 Security considerations .....	13
1.6 YANG module syntax validation .....	13
2. Normative references .....	14
3. Definitions .....	16
4. Abbreviations .....	17
5. Ethernet YANG Module .....	18
5.1 YANG module structure .....	18
5.2 Mapping of IEEE Std 802.3, Clause 30 managed objects .....	18
5.3 YANG module definition .....	23
5.3.1 Tree hierarchy .....	23
5.3.2 YANG module.....	26
5.3.2.1 Ethernet interface module.....	26
5.3.2.2 Ethernet interface module (half-duplex).....	43
6. YANG module for Ethernet data terminal equipment (DTE) power via medium dependent interface (MDI) and Power over Data Lines (PoDL) .....	50
6.1 Introduction.....	50
6.2 YANG module structure .....	50
6.3 Security considerations for Ethernet data terminal equipment (DTE) power via medium dependent interface (MDI) and Power over Data Line Module .....	50
6.4 Mapping of IEEE Std 802.3, Clause 30 managed objects .....	50
6.5 YANG module definition .....	53
6.5.1 Tree hierarchy .....	53
6.5.2 YANG module.....	54
7. YANG module for Ethernet Passive Optical Network (EPON).....	65
7.1 Introduction.....	65
7.2 YANG module structure .....	65
7.2.1 Introduction.....	65
7.2.2 Principles of operation .....	66
7.2.3 Physical media .....	67
7.2.4 PMD specifications.....	67
7.2.5 Principles of the MPCP.....	67
7.2.6 Forward error correction (FEC).....	69
7.2.7 Management architecture.....	70
7.3 Mapping of IEEE Std 802.3, Clause 30 managed objects .....	71
7.4 YANG module definition .....	77
7.4.1 Tree hierarchy .....	77

7.4.2	YANG module .....	80
8.	YANG module for Ethernet Link OAM (ELO) .....	123
8.1	Introduction.....	123
8.2	Overview.....	123
8.2.1	Remote fault indication.....	123
8.2.2	Link monitoring .....	123
8.2.3	Remote loopback .....	123
8.2.4	Ethernet OAM protocol data units.....	124
8.3	Security considerations for Ethernet operations, administration, and maintenance (OAM) module .....	124
8.4	Mapping of IEEE 802.3 managed objects .....	125
8.5	YANG module definition .....	129
8.5.1	Tree hierarchy .....	129
8.5.2	YANG module.....	133

IECNORM.COM : Click to view the full PDF of ISO/IEC/IEEE 8802-3-2:2021

# IEEE Standard for Ethernet YANG Data Model Definitions

## 1. Overview

This standard defines YANG modules for various Ethernet devices specified in IEEE Std 802.3. This includes half-duplex and full-duplex data terminal equipment (DTE) using either Carrier Sense Multiple Access/Collision Detection (CSMA/CD) or Multipoint Control Protocol (MPCP), and Power Sourcing Equipment (PSE).

### 1.1 Scope

This standard defines YANG data models for IEEE Std 802.3 Ethernet.

### 1.2 Purpose

The purpose of the standard is to define YANG modules for IEEE Std 802.3 and publish these modules in a machine-readable format.

### 1.3 Machine-readable YANG modules

The machine-readable files are available for download at the following URL: <https://github.com/YangModels/yang/tree/master/standard/ieee/published/802.3> as text files with a *.yang* extension, e.g., *ieee802-ether-net-interface.yang*. The use of specialized tools to view YANG modules may be useful to create tree, UML image, and HTML outputs from the YANG modules.

Like other languages, YANG (see IETF RFC 7950) has an accepted style for machine-readable files, which was followed during the development of this standard. This formatting may not be preserved when importing the machine-readable YANG modules into the PDF. In case of any formatting discrepancies, the published machine-readable files should be consulted.

### 1.4 Summary of YANG-based management framework

The structure of YANG-based management framework closely resembles the structure of the Internet-Standard Management Framework, described in detail in section 7 of IETF RFC 3410.

Managed objects defined using YANG modeling language are hosted on the managed device and accessed through NETCONF (see IETF RFC 7803) or RESTCONF (see IETF RFC 8040). This standard specifies YANG modules that are compliant to YANG 1.1 (see IETF RFC 7950).

### 1.5 Security considerations

The YANG modules defined in this standard are designed to be accessed via network management protocols, including NETCONF (see IETF RFC 7803) or RESTCONF (see IETF RFC 8040). The lowest NETCONF layer is the secure transport layer, and the mandatory-to-implement secure transport is Secure Shell (SSH) (see IETF RFC 6242) or TLS (see IETF RFC 8446). The lowest RESTCONF layer is HTTPS, and the mandatory-to-implement secure transport is TLS (see IETF RFC 8446).

The NETCONF access control model (see IETF RFC 8341) provides the means to restrict access for particular NETCONF or RESTCONF users to a pre-configured subset of all available NETCONF or RESTCONF protocol operations and content.

There are a number of data nodes defined in these YANG modules that are writable/creatable/deletable, i.e., have the config property set to true, which is the default setting. These data nodes may be considered sensitive or vulnerable in some network environments. Write operations (e.g., edit-config) to these data nodes without proper protection can have a negative effect on network operations.

Some of the readable data nodes in these YANG modules may be considered sensitive or vulnerable in some network environments. It is thus important to control read access (e.g., via get, get-config, or notification) to these data nodes.

Some of the RPC operations in these YANG modules may be considered sensitive or vulnerable in some network environments. Therefore, it is important to control access to these operations.

### 1.6 YANG module syntax validation

All YANG modules included in this standard are YANG 1.1 (see IETF RFC 7950) compliant and pass automated checks using tools available at the time of publication.

The following open source and/or free versions of YANG validation tools may be used: Pyang (see <https://github.com/mbj4668/pyang>), ConfD (see <http://www.tail-f.com/confd-basic>), as well as other YANG model validation tools listed at <http://www.yangvalidator.com>.

## 2. Normative references

The following referenced documents are indispensable for the application of this document (i.e., they must be understood and used, so each referenced document is cited in text and its relationship to this document is explained). For dated references, only the edition cited applies. For undated references, the latest edition of the referenced document (including any amendments or corrigenda) applies.

IEEE Std 802®-2014, IEEE Standard for Local and Metropolitan Area Networks: Overview and Architecture.<sup>1, 2</sup>

IEEE Std 802d™-2017, IEEE Standard for Local and Metropolitan Area Networks: Overview and Architecture Amendment 1: Allocation of Uniform Resource Name (URN) Values in IEEE 802 Standards.

IEEE Std 802.1Q™-2014, IEEE Standard for Local and metropolitan area networks—Bridges and Bridged Networks.

IEEE Std 802.3™-2018, IEEE Standard for Ethernet.

IEEE Std 802.3.1™-2013, IEEE Standard for Management Information Base (MIB) Definitions for Ethernet.

IETF RFC 2819, Remote Network Monitoring Management Information Base, S. Waldbusser, May 2000.<sup>3</sup>

IETF RFC 3410, *Introduction and Applicability Statements for Internet Standard Management Framework*, J. Case, R. Mundy, D. Partain, B. Stewart, December 2002.

IETF RFC 3621, *Power Ethernet MIB*, A. Berger, December 2003

IETF RFC 3635, *Definitions of Managed Objects for the Ethernet-like Interface Types*, J. Flick, September 2003.

IETF RFC 6242, *Using the NETCONF Protocol over Secure Shell (SSH)*, Wasserman M, June 2011.

IETF RFC 6991, *Common YANG Data Types*, Schoenwaelder J., July 2013.

IETF RFC 7803, *Changing the Registration Policy for the NETCONF Capability URNs Registry*, B. Leiba February 2016.

IETF RFC 7950, *The YANG 1.1 Data Modeling Language*, Bjorklund M., August 2016.

IETF RFC 8040, *RESTCONF Protocol*, Bierman A., Bjorklund M., and Watsen K., January 2017.

IETF RFC 8342, *Network Management Datastore Architecture (NMDA)*, M. Bjorklund, J. Schoenwaelder, P. Shafer, K. Watsen, and R. Wilton, March 2018.

IETF RFC 8341, *Network Configuration Access Control Model*, A. Bierman and M. Bjorklund, March 2018.

<sup>1</sup>The IEEE standards or products referred to in this clause are trademarks owned by the Institute of Electrical and Electronics Engineers, Incorporated.

<sup>2</sup>IEEE publications are available from the Institute of Electrical and Electronics Engineers (<http://standards.ieee.org/>).

<sup>3</sup>Internet Requests for Comments (RFCs) are available on the World Wide Web at the following ftp site: venera.isi.edu; logon: anonymous; password: user's e-mail address; directory: in-inotes.

IETF RFC 8343, *A YANG Data Model for Interface Management*, Bjorklund, M., March 2018.

IETF RFC 8407, *Guidelines for Authors and Reviewers of YANG Data Model Documents*, Bierman A., October 2018.

IETF RFC 8446, *The Transport Layer Security (TLS) Protocol Version 1.3*, E. Rescorla, August 2018.

IECNORM.COM : Click to view the full PDF of ISO/IEC/IEEE 8802-3-2:2021

### 3. Definitions

For the purposes of this document, the following terms and definitions apply. Some terms used in this document are defined in IEEE Std 802.3, and where alternative definitions occur in the IEEE Standards Dictionary, the IEEE Std 802.3 definition should be used. The *IEEE Standards Dictionary Online* should be consulted for terms not defined in this clause.<sup>4</sup>

**3.1 data model:** A data model describes how data is represented and accessed.

**3.2 YANG module:** A YANG module defines a hierarchy of nodes that can be used for NETCONF-based (see IETF RFC 7803) and RESTCONF-based (see IETF RFC 8040) operations. With its definitions and the definitions it imports or includes from elsewhere, a module is self-contained and can be compiled.

IECNORM.COM : Click to view the full PDF of ISO/IEC/IEEE 8802-3-2:2021

---

<sup>4</sup>*IEEE Standards Dictionary Online* is available at: <http://dictionary.ieee.org/>.

## 4. Abbreviations

This standard contains the following abbreviations:

CO	Central Office
CPE	Customer Premise Equipment
CSMA/CD	carrier sense multiple access with collision detection
DTE	data terminal equipment
EFM	Ethernet in the First Mile
ELO	Ethernet Link OAM
EPON	Ethernet passive optical networks
IEEE	Institute of Electrical and Electronics Engineers
IETF	Internet Engineering Task Force
NETCONF	Network Configuration Protocol
OAM	Operations, Administration, and Maintenance
PoE	Power over Ethernet
RESTCONF	RESTful Configuration Protocol
YANG	Yet Another Next Generation

IECNORM.COM : Click to view the full PDF of ISO/IEC/IEEE 8802-3-2:2021

## 5. Ethernet YANG Module

### 5.1 YANG module structure

Two modules defined in this clause are focused on the configuration and monitoring of IEEE Std 802.3 Ethernet interfaces. The *ieee802-ethernet-interface* YANG module contains definitions of current attributes used widely in the industry in current products, while the *ieee802-ethernet-interface-half-duplex* YANG module contains definitions of half-duplex attributes.

This standard does not have a normative requirement for data nodes of the base *ietf-interfaces* YANG module, but the following data nodes are supported: name, description, type, enabled, admin-status, oper-status, if-index, and phys-address.

### 5.2 Mapping of IEEE Std 802.3, Clause 30 managed objects

This subclause contains the mapping between YANG data nodes included in *ieee802-ethernet-interface* (see Table 5–1) and *ieee802-ethernet-interface-half-duplex* (see Table 5–4) YANG modules, managed objects, and attributes defined in IEEE Std 802.3, Clause 30.

IECNORM.COM : Click to view the full PDF of ISO/IEC/IEEE 8802-3-2:2021

Table 5-1—Mapping between IEEE Std 802.3, Clause 30 managed objects and ieee802-ethernet-interface YANG data nodes

IEEE Std 802.3, Clause 30		Corresponding <i>ieee802-ethernet-interface</i> YANG data nodes			
Managed object(s)	Attribute(s)	Reference	Container(s)	Data node(s)	R/W
oAutoNegotiation	acAutoNegAdminControl	30.6.1.2.2	interfaces/interface/ethernet/	auto-negotiation/enable	R/W
	aAutoNegAutoConfig	30.6.1.1.4		negotiation-status	R
N/A	N/A			flow-control/pause/direction	R/W
	oMACControlFunctionEntity	30.3.4.3		flow-control/pause/statistics/in-frames-pause	R
	aPAUSEMACCtrlFramesTransmitted	30.3.4.2		flow-control/pause/statistics/out-frames-pause	R
N/A	dot3HCOutPFCFrames				
N/A	N/A			flow-control/force-flow-control	R/W
N/A	N/A			speed	R/W
oMACEntity	aDuplexStatus	30.3.1.1.32		duplex	R/W
	aMaxFrameLength	30.3.1.1.37		max-frame-length	R
	aSlowProtocolFrameLimit	30.3.1.1.38		frame-limit-slow-protocol	R
oEXTENSION	aEXTENSIONMACCtrlStatus	30.3.8.3		mac-control-extension-control	R
N/A	N/A			capabilities/auto-negotiation	R

Table 5-1—Mapping between IEEE Std 802.3, Clause 30 managed objects and ieee802-ethernet-interface YANG data nodes (continued)

IEEE Std 802.3, Clause 30		Corresponding ieee802-ethernet-interface YANG data nodes			
Managed object(s)	Attribute(s)	Reference	Container(s)	Data node(s)	R/W
oMACEntity	aFramesReceivedOK	30.3.1.1.5	interfaces/interface/ethernet/statistics/frame	in-frames	R
	aMulticastFramesReceivedOK	30.3.1.1.21		in-multicast-frames	R
	aBroadcastFramesReceivedOK	30.3.1.1.22		in-broadcast-frames	R
	aFrameCheckSequenceErrors + aAlignmentErrors	30.4.3.1.6, 30.4.3.1.7		in-error-fcs-frames	R
	aFrameTooLongErrors	30.3.1.1.25		in-error-oversize-frames	R
	aFramesLostDueToIntMACRcvError	30.3.1.1.15		in-error-mac-internal-frames	R
	aFramesTransmittedOK	30.3.1.1.2		out-frames	R
oPHYEntity	aMulticastFramesXmittedOK	30.3.1.1.18	interfaces/interface/ethernet/statistics/phy	out-multicast-frames	R
	aBroadcastFramesXmittedOK	30.3.1.1.19		out-broadcast-frames	R
	aFramesLostDueToIntMACXmitError	30.3.1.1.12		out-error-mac-internal-frames	R
	aSymbolErrorDuringCarrier	30.3.2.1.5		in-error-symbol	R
	aReceiveLPITransitions	30.3.2.1.11		in-lpi-transitions	R
	aReceiveLPIMicroseconds	30.3.2.1.9		in-lpi-time	R
	aTransmitLPITransitions	30.3.2.1.10		out-lpi-transitions	R
aTransmitLPIMicroseconds	30.3.2.1.8	out-lpi-time	R		

Table 5-1—Mapping between IEEE Std 802.3, Clause 30 managed objects and ieee802-ethernet-interface YANG data nodes (continued)

IEEE Std 802.3, Clause 30		Corresponding <i>ieee802-ethernet-interface</i> YANG data nodes			
Managed object(s)	Attribute(s)	Reference	Container(s)	Data node(s)	R/W
oMACControlEntity	aUnsupportedOpCodesReceived	30.3.3.5	interfaces/interface/ethernet/statistics/mac-control	in-frames-mac-control-unknown	R
oEXTENSION	aEXTENSIONMACCtrlFramesReceived	30.3.8.2	interfaces/interface/ethernet/statistics/mac-control	in-frames-mac-control-extension	R
	aEXTENSIONMACCtrlFramesTransmitted	30.3.8.1		out-frames-mac-control-extension	R

Table 5-2—Mapping between IETF RFC 2819 managed objects and ieee802-ethernet-interface YANG data nodes

IETF RFC 2819 Attribute(s)		Corresponding <i>ieee802-ethernet-interface</i> YANG data nodes		
		Container(s)	Data node(s)	R/W
no direct object <sup>a</sup>		interfaces/interface/ethernet/statistics/frame	in-total-frames	R
etherStatsOctets			in-total-octets	R
etherStatsUndersizePkts + etherStatsFragments			in-error-undersize-frames	R

<sup>a</sup> Can be calculated as: aFramesReceivedOK + aFrameCheckSequenceErrors + aAlignmentErrors + aFrameTooLongErrors + aFramesLostDuplicateToIntMACRevError.

Table 5-3—Mapping between IETF RFC 3635 managed objects and *ieee802-ethernet-interface* YANG data nodes

ETHERLIKE MIB Attribute(s)		Corresponding <i>ieee802-ethernet-interface</i> YANG data nodes	
	Container(s)	Data node(s)	R/W
dot3HCInPFCFrames	interfaces/interface/ethernet/	flow-control/pfc {ethernet-pfc} / statistics/in-frames-pfc	R
dot3HCOutPFCFrames		flow-control/pfc {ethernet-pfc} / statistics/out-frames-pfc	R

Table 5-4—Mapping between IEEE Std 802.3, Clause 30 managed objects and *ieee802-ethernet-interface-half-duplex* YANG data nodes

IEEE Std 802.3, Clause 30		Corresponding <i>ieee802-ethernet-interface-half-duplex</i> YANG data nodes	
Managed object(s)	Attribute(s)	Container(s)	Data node(s) R/W
oMACTEntity	aRateControlAbility	interfaces/interface/ethernet	dynamic-rate-control R/W
	aSQETestErrors	interfaces/interface/ethernet/capability	dynamic-rate-control-supported R
oPHYEntity	aSingleCollisionFrames	interfaces/interface/ethernet/statistics/frame/csmacd {csma-cd}	in-errors-sqe-test R
	aMultipleCollisionFrames		out-frames-collision-single R
	aFramesWithDeferredXmissions		out-frames-collision-multiple R
	aFramesAbortedDueToXSColls		out-frames-deferred R
	aLateCollisions		out-frames-collisions-excessive R
	aCarrierSenseErrors		out-collisions-late R
aCollisionFrames			out-etfrons-carrier-sense R
			collision-histogram/collision-count R
			collision-histogram/collision-count-frames R

### 5.3 YANG module definition<sup>5</sup>

The YANG module tree hierarchy uses terms defined in IETF RFC 8407.

#### 5.3.1 Tree hierarchy

```

module: ieee802-ethernet-interface
  augment /if:interfaces/if:interface:
    +--rw ethernet
      +--rw auto-negotiation!
      | +--rw enable? boolean
      | +--ro negotiation-status? enumeration
      | +--rw duplex? duplex-type
      | +--rw speed? eth-if-speed-type
      +--rw flow-control
      | +--rw pause {ethernet-pause}?
      | | +--rw direction? pause-fc-direction-type
      | | +--ro statistics
      | | +--ro in-frames-pause? yang:counter64
      | | +--ro out-frames-pause? yang:counter64
      | +--rw pfc {ethernet-pfc}?
      | | +--rw enable? boolean
      | | +--ro statistics
      | | +--ro in-frames-pfc? yang:counter64
      | | +--ro out-frames-pfc? yang:counter64
      | +--rw force-flow-control? boolean
      +--ro max-frame-length? uint16
      +--ro mac-control-extension-control? boolean
      +--ro frame-limit-slow-protocol? uint64
      +--ro capabilities
      | +--ro auto-negotiation? boolean
      +--ro statistics
      +--ro frame
      | +--ro in-total-frames? yang:counter64

```

<sup>5</sup> Copyright release for YANG modules: Users of this standard may freely reproduce the YANG module contained in this subclause so that it can be used for its intended purpose.



```

+---ro out-frames-collisions-excessive? yang:counter64
+---ro out-collisions-late? yang:counter64
+---ro out-errors-carrier-sense? yang:counter64
+---ro collision-histogram* [collision-count]
    +---ro collision-count yang:counter64
    +---ro collision-count-frames? yang:counter64
    
```

PDFCITY.COM : Click to view the full PDF of ISO/IEC/IEEE 8802-3-2:2021

### 5.3.2 YANG module

In the following YANG module definitions, should any discrepancy between the text of the description for individual YANG nodes and the corresponding definition in 5.2 through 5.3 of this clause occur, the definitions and mappings in 5.3 shall take precedence.

An ASCII text version of the Ethernet YANG module can be found at the following URL:<sup>6</sup>  
<https://github.com/YangModels/yang/tree/master/standard/ieee/published/802.3>.

#### 5.3.2.1 Ethernet interface module

```

module ieee802-ethernet-interface {
  yang-version 1.1;

  namespace
    "urn:ieee:std:802.3:yang:ieee802-ethernet-interface";

  prefix ieee802-eth-if;

  revision 2019-06-21 {
    description "Initial revision.";
  }

  import ietf-yang-types {
    prefix yang;
    reference "IETF RFC 6991";
  }

  import ietf-interfaces {
    prefix if;
    reference "IETF RFC 8343";
  }

  import iana-if-type {
    prefix ianaift;
    reference "http://www.iana.org/assignments/yang-parameters/iana-if-type@2018-07-03.yang";
  }

  organization
    "IEEE Std 802.3 Ethernet Working Group
    Web URL: http://www.ieee802.org/3/";

  contact
    "Web URL: http://www.ieee802.org/3/";

  description
    "This module contains YANG definitions for configuring IEEE Std
    802.3 Ethernet Interfaces.
    In this YANG module, 'Ethernet interface' can be interpreted
    as referring to 'IEEE Std 802.3 compliant Ethernet
  
```

<sup>6</sup>Copyright release for YANG modules: Users of this standard may freely reproduce the YANG module contained in this subclause so that it can be used for its intended purpose.

```

    interfaces'.";

reference "IEEE Std 802.3-2018, unless dated explicitly";

typedef eth-if-speed-type {
    type decimal64 {
        fraction-digits 3;
    }
    units "Gb/s";
    description
        "Used to represent the configured, negotiated, or actual speed
        of an Ethernet interface in Gigabits per second (Gb/s),
        accurate to 3 decimal places (i.e., accurate to 1 Mb/s).";
}

typedef duplex-type {
    type enumeration {
        enum full {
            description
                "Full duplex.";
        }
        enum half {
            description
                "Half duplex.";
        }
        enum unknown {
            description
                "Link is currently disconnected or initializing.";
        }
    }
    default full;
    description
        "Used to represent the configured, negotiated, or actual
        duplex mode of an Ethernet interface.";
    reference "IEEE Std 802.3, 30.3.1.1.32, aDuplexStatus";
}

typedef pause-fc-direction-type {
    type enumeration {
        enum "disabled" {
            description
                "Flow-control disabled in both ingress and egress
                directions, i.e., PAUSE frames are not transmitted and
                PAUSE frames received in the ingress direction are
                discarded without processing.";
        }
        enum "ingress-only" {
            description
                "PAUSE frame based flow control is enabled in the ingress
                direction only, i.e., PAUSE frames may be transmitted to
                reduce the ingress traffic flow, but PAUSE frames received
                in the ingress direction are discarded without reducing
                the egress traffic rate.";
        }
    }
}

```

```

enum "egress-only" {
  description
    "PAUSE frame based flow control is enabled in the egress
    direction only, i.e., PAUSE frames are not transmitted,
    but PAUSE frames received in the ingress direction are
    processed to reduce the egress traffic rate.";
}
enum "bi-directional" {
  description
    "PAUSE frame based flow control is enabled in both ingress
    and egress directions, i.e., PAUSE frames may be
    transmitted to reduce the ingress traffic flow, and
    PAUSE frames received on ingress are processed to reduce
    the egress traffic rate.";
}
enum "undefined" {
  description
    "Link is currently disconnected or initializing.";
}
}
description
  "Used to represent the configured, negotiated, or actual
  PAUSE frame-based flow control setting.";

reference
  "IEEE Std 802.3.1, dot3PauseAdminMode and dot3PauseOperMode";
}

feature ethernet-pfc {
  description
    "This device supports Ethernet priority flow-control.";
}

feature ethernet-pause {
  description
    "This device supports Ethernet PAUSE.";
}

augment "/if:interfaces/if:interface" {
  when "derived-from-or-self(if:type, 'ianaift:ethernetCsmacd')" {
    description
      "Applies to all P2P Ethernet interfaces.";
  }
  description
    "Augment interface model with Ethernet interface
    specific configuration nodes.";

  container ethernet {
    description
      "Contains all Ethernet interface related configuration.";

    container auto-negotiation {
      presence
        "The presence of this container indicates that

```

IEEE Std 802.3.2-2019  
IEEE Standard for Ethernet YANG Data Model Definitions

```

    auto-negotiation is supported on this Ethernet
    interface.";
description
    "Contains auto-negotiation transmission parameters

    This container contains a data node that allows the
    advertised duplex value in the negotiation to be
    restricted.

    If not specified then the default behavior for the duplex
    data node is to negotiate all available values for the
    particular type of Ethernet PHY associated with the
    interface.

    If auto-negotiation is enabled, and PAUSE frame based flow
    control has not been explicitly configured, then the
    default PAUSE frame based flow control capabilities that
    are negotiated allow for bi-directional or egress-only
    PAUSE frame based flow control.

    If auto-negotiation is enabled, and PAUSE frame based flow
    control has been explicitly configured, then the
    configuration settings restrict the values that may be
    negotiated. However, it should be noted that the protocol
    does not allow only egress PAUSE frame based flow control
    to be negotiated without also allowing bi-directional
    PAUSE frame based flow control.";
reference
    "IEEE Std 802.3, Clause 28 and Annexes 28A-D";

leaf enable {
    type boolean;
    default true;

    description
        "Controls whether auto-negotiation is enabled or
        disabled.
        For interface types that support auto-negotiation then
        it defaults to being enabled.

        For interface types that do not support auto-negotiation,
        the related configuration data is ignored.";
}
leaf negotiation-status {
    when "../enable = 'true'";
    type enumeration {
        enum in-progress {
            description
                "The auto-negotiation protocol is running and
                negotiation is currently in-progress.";
        }
        enum complete {
            description
                "The auto-negotiation protocol has completed

```

```

        successfully.";
    }
    enum failed {
        description
            "The auto-negotiation protocol has failed.";
    }
    enum unknown {
        description
            "The auto-negotiation status is not currently known,
            this could be because it is still negotiating or the
            protocol cannot run (e.g., if no medium is present)";
    }
    enum no-negotiation {
        description
            "No auto-negotiation is executed.
            The auto-negotiation function is either not supported
            on this interface or has not been enabled.";
    }
    }
    config false;
    description
        "The status of the auto-negotiation protocol.";
    reference
        "IEEE 802.3, 30.6.1.1.4, aAutoNegAutoConfig";
}

}

leaf duplex {
    type duplex-type;
    description
        "Operational duplex mode of the Ethernet interface.";
    reference
        "IEEE Std 802.3, 30.3.1.1.32 aDuplexStatus";
}

leaf speed {
    type eth-if-speed-type;
    units "Gb/s";
    description
        "Operational speed (data rate) of the Ethernet interface.
        The default value is implementation-dependent.";
}

container flow-control {
    description
        "Holds the different types of Ethernet PAUSE frame based
        flow control that can be enabled.";
    container pause {
        if-feature "ethernet-pause";
        description
            "IEEE Std 802.3 PAUSE frame based PAUSE frame based flow
            control.";
        reference

```

IEEE Std 802.3.2-2019  
IEEE Standard for Ethernet YANG Data Model Definitions

```

    "IEEE Std 802.3, Annex 31B";
leaf direction {
  type pause-fc-direction-type;
  description
    "Indicates which direction PAUSE frame based flow
    control is enabled in, or whether it is disabled.
    The default flow-control settings are vendor specific.
    If auto-negotiation is enabled, then PAUSE based
    flow-control is negotiated by default.
    The default value is implementation-dependent.";
}

container statistics {
  config false;
  description
    "Contains the number of PAUSE frames received or
    transmitted.";
  leaf in-frames-pause {
    type yang:counter64;
    units frames;
    description
      "A count of PAUSE MAC Control frames transmitted on
      this Ethernet interface.

      Discontinuities in the values of counters in
      this container can occur at re-initialization of the
      management system, and at other times as indicated
      by the value of the 'discontinuity-time' leaf
      defined in the ietf-interfaces YANG module
      (IETF RFC 8343).";
    reference
      "IEEE Std 802.3, 30.3.4.3 aPAUSEMACCtrlFramesReceived";
  }
  leaf out-frames-pause {
    type yang:counter64;
    units frames;
    description
      "A count of PAUSE MAC Control frames transmitted on
      this Ethernet interface.

      Discontinuities in the values of counters in
      this container can occur at re-initialization of the
      management system, and at other times as indicated
      by the value of the 'discontinuity-time' leaf
      defined in the ietf-interfaces YANG module
      (IETF RFC 8343).";
    reference
      "IEEE Std 802.3, 30.3.4.2
      aPAUSEMACCtrlFramesTransmitted";
  }
}
}

container pfc {

```

```

if-feature "ethernet-pfc";
description
  "IEEE Std 802.3 Priority-based flow control.";
reference
  "IEEE Std 802.3, Annex 31D";

leaf enable {
  type boolean;

  description
    "True indicates that IEEE Std 802.3 priority-based
    flow control is enabled, false indicates that
    IEEE Std 802.3 priority-based flow control is disabled.
    For interfaces that have auto-negotiation,
    the priority-based flow control is enabled by default.";
}

container statistics {
  config false;
  description
    "This container collects all statistics for
    Ethernet interfaces.";

  leaf in-frames-pfc {
    type yang:counter64;
    units frames;
    description
      "A count of PFC MAC Control frames received on this
      Ethernet interface.

      Discontinuities in the values of counters in
      this container can occur at re-initialization of the
      management system, and at other times as indicated
      by the value of the 'discontinuity-time' leaf
      defined in the ietf-interfaces YANG module
      (IETF RFC 8343).";
    reference
      "IEEE Std 802.3.1, dot3HCInPFCFrames";
  }

  leaf out-frames-pfc {
    type yang:counter64;
    units frames;
    description
      "A count of PFC MAC Control frames transmitted on
      this interface.

      Discontinuities in the values of counters in
      this container can occur at re-initialization of the
      management system, and at other times as indicated
      by the value of the 'discontinuity-time' leaf
      defined in the ietf-interfaces YANG module
      (IETF RFC 8343).";
    reference

```

IEEE Std 802.3.2-2019  
IEEE Standard for Ethernet YANG Data Model Definitions

```

        "IEEE Std 802.3.1, dot3HCInPFCFrames";
    }
}

leaf force-flow-control {
    type boolean;
    default false;
    description
        "Explicitly forces the local PAUSE frame based flow control
        settings regardless of what has been negotiated.

        Since the auto-negotiation of flow-control settings
        does not allow all sane combinations to be negotiated
        (e.g., consider a device that is only capable of sending
        PAUSE frames connected to a peer device that is only
        capable of receiving and acting on PAUSE frames) and
        failing to agree on the flow-control settings does not
        cause the auto-negotiation to fail completely, then it is
        sometimes useful to be able to explicitly enable
        particular PAUSE frame based flow control settings on
        the local device regardless of what is being advertised
        or negotiated.";
    reference
        "IEEE Std 802.3, Table 28B-3";
}

leaf max-frame-length {
    type uint16;
    units octets;
    config false;
    description
        "This indicates the MAC frame length (including FCS bytes)
        at which frames are dropped for being too long.";
    reference
        "IEEE Std 802.3, 30.3.1.1.37 aMaxFrameLength";
}

leaf mac-control-extension-control {
    type boolean;
    config false;
    description
        "A value that identifies the current EXTENSION MAC Control
        function, as specified in IEEE Std 802.3, Annex 31C.";
    reference
        "IEEE Std 802.3, 30.3.8.3 aEXTENSIONMACCtrlStatus
        IEEE Std 802.3.1, dot3ExtensionMacCtrlStatus ";
}

leaf frame-limit-slow-protocol {
    type uint64;
    units f/s;
    default 10;
}

```

```

config false;
description
  "The maximum number of Slow Protocol frames of a given
  subtype that can be transmitted in a one second interval.
  The default value is 10.";
reference
  "IEEE Std 802.3, 30.3.1.1.38 aSlowProtocolFrameLimit";
}

container capabilities {
  config false;
  description
    "Container all Ethernet interface specific capabilities."

  leaf auto-negotiation {
    type boolean;
    description
      "Indicates whether auto-negotiation may be configured on
      this interface.";
  }
}

container statistics {
  config false;
  description
    "Contains statistics specific to Ethernet interfaces.

    Discontinuities in the values of counters in the
    container can occur at re-initialization of the management
    system, and at other times as indicated by the value of
    the 'discontinuity-time' leaf defined in the
    ietf-interfaces YANG module (IETF RFC 8343).";

  container frame {
    description
      "Contains frame statistics specific to Ethernet
      interfaces.

      All octet frame lengths include the 4 byte FCS.

      Error counters are only reported once ... The count
      represented by an instance of this object is incremented
      when the frameCheckError status is returned by the MAC
      service to the LLC (or other MAC user). Received frames
      for which multiple error conditions pertain are,
      according to the conventions of IEEE Std 802.3 Layer
      Management, counted exclusively according to the error
      status presented to the LLC.

      A frame that is counted by an instance of this object is
      also counted by the corresponding instance of 'in-errors'
      leaf defined in the ietf-interfaces YANG module
      (IETF RFC 8343).
    
```

IEEE Std 802.3.2-2019  
IEEE Standard for Ethernet YANG Data Model Definitions

Discontinuities in the values of counters in the container can occur at re-initialization of the management system, and at other times as indicated by the value of the 'discontinuity-time' leaf defined in the ietf-interfaces YANG module (IETF RFC 8343).";

```
leaf in-total-frames {
  type yang:counter64;
  units frames;
  description
    "The total number of frames (including bad frames)
    received on the Ethernet interface.

    This counter is calculated by summing the following
    IEEE Std 802.3, Clause 30 counters:
    aFramesReceivedOK +
    aFrameCheckSequenceErrors +
    aAlignmentErrors +
    aFrameTooLongErrors +
    aFramesLostDueToIntMACRcvError

    Also see the 'description' statement associated with
    the parent 'statistics' container for additional
    common semantics related to this counter.";

  reference
    "IEEE Std 802.3, Clause 30 counters, as specified
    in the description above.";
}

leaf in-total-octets {
  type yang:counter64;
  units octets;
  description
    "The total number of octets of data (including those in
    bad frames) received on the Ethernet interface.

    Includes the 4-octet FCS.

    Also see the 'description' statement associated with
    the parent 'statistics' container for additional
    common semantics related to this counter.";

  reference
    "IETF RFC 2819, etherStatsOctets";
}

leaf in-frames {
  type yang:counter64;
  units frames;
  description
    "A count of frames (including unicast, multicast and
    broadcast) that have been successfully received on the
```

Ethernet interface.

This count does not include frames received with frame-too-long, FCS, length or alignment errors, or frames lost due to internal MAC sublayer error.

Also see the 'description' statement associated with the parent 'statistics' container for additional common semantics related to this counter.";

```
reference
  "IEEE Std 802.3, 30.3.1.1.5 aFramesReceivedOK";
}

leaf in-multicast-frames {
  type yang:counter64;
  units frames;
  description
    "A count of multicast frames that have been
    successfully received on the Ethernet interface.

    This counter represents a subset of the frames counted
    by in-frames.

    This count does not include frames received with
    frame-too-long, FCS, length or alignment errors, or
    frames lost due to internal MAC sublayer error.

    Also see the 'description' statement associated with
    the parent 'statistics' container for additional
    common semantics related to this counter.";

  reference
    "IEEE Std 802.3, 30.3.1.1.21 aMulticastFramesReceivedOK";
}

leaf in-broadcast-frames {
  type yang:counter64;
  units frames;
  description
    "A count of broadcast frames that have been
    successfully received on the Ethernet interface.

    This counter represents a subset of the frames counted
    by in-frames.

    This count does not include frames received with
    frame-too-long, FCS, length or alignment errors, or
    frames lost due to internal MAC sublayer error.

    Also see the 'description' statement associated with
    the parent 'statistics' container for additional
    common semantics related to this counter.";
```

IEEE Std 802.3.2-2019  
IEEE Standard for Ethernet YANG Data Model Definitions

```

reference
  "IEEE Std 802.3, 30.3.1.1.22 aBroadcastFramesReceivedOK";
}

leaf in-error-fcs-frames {
  type yang:counter64;
  units frames;
  description
    "A count of receive frames that are of valid length,
    but do not pass the FCS check, regardless of whether
    or not the frames are an integral number of octets in
    length.

    This count effectively comprises
    aFrameCheckSequenceErrors and aAlignmentErrors added
    together.

    Also see the 'description' statement associated with
    the parent 'statistics' container for additional
    common semantics related to this counter.";

  reference
    "IEEE Std 802.3, 30.3.1.1.6 aFrameCheckSequenceErrors;
    IEEE Std 802.3, 30.3.1.1.7 aAlignmentErrors";
}

leaf in-error-undersize-frames {
  type yang:counter64;
  units frames;
  description
    "A count of frames received on a particular Ethernet
    interface that are less than 64 bytes in length, and
    are discarded.

    This counter is incremented regardless of whether the
    frame passes the FCS check.

    Also see the 'description' statement associated with
    the parent 'statistics' container for additional
    common semantics related to this counter.";

  reference
    "IETF RFC 2819, etherStatsUndersizePkts and
    etherStatsFragments";
}

leaf in-error-oversize-frames {
  type yang:counter64;
  units frames;
  description
    "A count of frames received on a particular Ethernet
    interface that exceed the maximum permitted frame
    size, that is specified in max-frame-length, and are
    discarded.

```

This counter is incremented regardless of whether the frame passes the FCS check.

Also see the 'description' statement associated with the parent 'statistics' container for additional common semantics related to this counter.";

```
reference "IEEE Std 802.3, 30.3.1.1.25 aFrameTooLongErrors";
}
```

```
leaf in-error-mac-internal-frames {
  type yang:counter64;
  units frames;
  description
    "A count of frames for which reception on a particular
    Ethernet interface fails due to an internal MAC
    sublayer receive error.

    A frame is only counted by an instance of this object
    if it is not counted by the corresponding instance of
    either the in-error-fcs-frames, in-error-undersize-frames,
    or in-error-oversize-frames. The precise meaning of the
    count represented by an instance of this object is
    implementation-specific.
```

In particular, an instance of this object may represent a count of receive errors on a particular Ethernet interface that are not otherwise counted.

Also see the 'description' statement associated with the parent 'statistics' container for additional common semantics related to this counter.";

```
reference
  "IEEE Std 802.3, 30.3.1.1.15
  aFramesLostDueToIntMACRcvError";
}
```

```
leaf out-frames {
  type yang:counter64;
  units frames;
  description
    "A count of frames (including unicast, multicast and
    broadcast) that have been successfully transmitted on
    the Ethernet interface.
```

Also see the 'description' statement associated with the parent 'statistics' container for additional common semantics related to this counter.";

```
reference
  "IEEE Std 802.3, 30.3.1.1.2 aFramesTransmittedOK";
}
```

```
leaf out-multicast-frames {
  type yang:counter64;
  units frames;
  description
    "A count of multicast frames that have been
    successfully transmitted on the Ethernet interface.

    This counter represents a subset of the frames counted
    by out-frames.

    Also see the 'description' statement associated with
    the parent 'statistics' container for additional
    common semantics related to this counter.";

  reference
    "IEEE Std 802.3, 30.3.1.1.18 aMulticastFramesXmittedOK";
}

leaf out-broadcast-frames {
  type yang:counter64;
  units frames;
  description
    "A count of broadcast frames that have been
    successfully transmitted on the Ethernet interface.

    This counter represents a subset of the frames counted
    by out-frames.

    Also see the 'description' statement associated with
    the parent 'statistics' container for additional
    common semantics related to this counter.";

  reference
    "IEEE Std 802.3, 30.3.1.1.19 aBroadcastFramesXmittedOK";
}

leaf out-error-mac-internal-frames {
  type yang:counter64;
  units frames;
  description
    "A count of frames for which transmission on a
    particular Ethernet interface fails due to an internal
    MAC sublayer transmit error.

    The precise meaning of the count represented by an
    instance of this object is implementation-specific. In
    particular, an instance of this object may represent a
    count of transmission errors on a particular Ethernet
    interface that are not otherwise counted.

    Also see the 'description' statement associated with
    the parent 'statistics' container for additional
    common semantics related to this counter.";
```

```

reference
  "IEEE Std 802.3, 30.3.1.1.12
  aFramesLostDueToIntMACXmitError";
}
}

container phy {
  description
    "Ethernet statistics related to the PHY layer.

    Discontinuities in the values of counters in the
    container can occur at re-initialization of the
    management system, and at other times as indicated by
    the value of the 'discontinuity-time' leaf defined in
    the ietf-interfaces YANG module (IETF RFC 8343).";

  leaf in-error-symbol {
    type yang:counter64;
    units errors;
    description
      "A count of the number of symbol errors that have
      occurred.

      For the precise definition of when the symbol error
      counter is incremented, please see the 'description'
      text associated with aSymbolErrorDuringCarrier,
      specified in IEEE Std 802.3, 30.3.2.1.5.

      Also see the 'description' statement associated with
      the parent 'phy-statistics' container for additional
      common semantics related to this counter.";
    reference
      "IEEE Std 802.3, 30.3.2.1.5 aSymbolErrorDuringCarrier";
  }

  container lpi {
    description
      "Physical Ethernet statistics for the energy efficiency
      related low power idle indications.";

    leaf in-lpi-transitions {
      type yang:counter64;
      units transitions;
      description
        "A count of occurrences of the transition from
        DEASSERT to ASSERT of the LPI_INDICATE
        parameter. The indication reflects the state of the
        PHY according to the requirements of the RS (see
        IEEE Std 802.3, 22.7, 35.4, and 46.4).

        Also see the 'description' statement associated with
        the parent 'phy-statistics' container for additional
        common semantics related to this counter.";
    }
  }
}

```

IEEE Std 802.3.2-2019  
IEEE Standard for Ethernet YANG Data Model Definitions

```

reference
  "IEEE Std 802.3, 30.3.2.1.11 aReceiveLPITransitions";
}

leaf in-lpi-time {
  type decimal64 {
    fraction-digits 6;
  }
  units seconds;
  description
    "A count reflecting the total amount of time (in
    seconds) that the LPI_REQUEST parameter has the
    value ASSERT. The request is indicated to the PHY
    according to the requirements of the RS (see IEEE Std
    802.3, 22.7, 35.4, and 46.4).

    Also see the 'description' statement associated with
    the parent 'phy-statistics' container for additional
    common semantics related to this counter.";

reference
  "IEEE Std 802.3, 30.3.2.1.9 aReceiveLPIMicroseconds";
}

leaf out-lpi-transitions {
  type yang:counter64;
  units transitions;
  description
    "A count of occurrences of the transition from state
    LPI_DEASSERTED to state LPI_ASSERTED in the LPI
    transmit state diagram of the RS. The state
    transition corresponds to the assertion of the
    LPI_REQUEST parameter. The request is indicated to
    the PHY according to the requirements of the RS (see
    IEEE Std 802.3, 22.7, 35.4, 46.4.)

    Also see the 'description' statement associated with
    the parent 'phy-statistics' container for additional
    common semantics related to this counter.";

reference
  "IEEE Std 802.3, 30.3.2.1.10 aTransmitLPITransitions";
}

leaf out-lpi-time {
  type decimal64 {
    fraction-digits 6;
  }
  units seconds;
  description
    "A count reflecting the total amount of time (in
    seconds) that the LPI_INDICATION parameter has the
    value ASSERT. The request is indicated to the PHY

```

according to the requirements of the RS (see IEEE 802.3, 22.7, 35.4, and 46.4).

Also see the 'description' statement associated with the parent 'phy-statistics' container for additional common semantics related to this counter.";

```

reference
  "IEEE Std 802.3, 30.3.2.1.8 aTransmitLPIMicroseconds";
}
}
}

container mac-control {
  description
    "A group of statistics specific to MAC Control operation
    of selected Ethernet interfaces.

    Discontinuities in the values of counters in the
    container can occur at re-initialization of the
    management system, and at other times as indicated by
    the value of the 'discontinuity-time' leaf defined in
    the ietf-interfaces YANG module (IETF RFC 8343).";

  reference
    "IEEE Std 802.3.1, dot3ExtensionTable";

  leaf in-frames-mac-control-unknown {
    type yang:counter64;
    units frames;
    description
      "A count of MAC Control frames with an unsupported
      opcode received on this Ethernet interface.

      Frames counted against this counter are also counted
      against in-discards defined in the ietf-interfaces
      YANG module (IETF RFC 8343).

      Also see the 'description' statement associated with
      the parent 'mac-control-statistics' container for
      additional semantics.";
    reference
      "IEEE Std 802.3, 30.3.3.5 aUnsupportedOpCodesReceived";
  }

  leaf in-frames-mac-control-extension {
    type yang:counter64;
    units frames;
    description
      "The count of Extension MAC Control frames received on
      this Ethernet interface.

      Also see the 'description' statement associated with
      the parent 'mac-control-statistics' container for

```



```
import ieee802-ethernet-interface {
  prefix ieee802-eth-if;
}

organization
  "IEEE Std 802.3 Ethernet Working Group
  Web URL: http://www.ieee802.org/3/";

contact
  "Web URL: http://www.ieee802.org/3/";

description
  "This module contains YANG definitions for configuring Ethernet
  interfaces that are deprecated, and are no longer
  widely used in the industry. The definitions are maintained for
  backwards compatibility purposes, but the general expectation is
  that this module is not anticipated to be widely implemented.";
reference
  "IEEE Std 802.3-2018, unless dated explicitly";

feature dynamic-rate-control {
  description
    "This feature indicates that the device supports Ethernet
    interfaces lowering the average data rate of the MAC sublayer,
    with frame granularity, by using Rate Control to dynamically
    increase the inter-packet gap for some types of Ethernet
    interface.
    Only valid for Ethernet interfaces operating at speeds (data rates)
    above 1000 Mb/s.";
  reference "IEEE Std 802.3, 30.3.1.1.33 aRateControlAbility";
}

feature csma-cd {
  description
    "This feature indicates that the device supports Ethernet
    interfaces running at half-duplex using CSMA/CD.";
}

typedef dynamic-rate-control-type {
  type enumeration {
    enum disabled {
      description
        "Dynamic rate control is disabled";
    }
    enum "sonet-oc192" {
      value 2;
      description
        "Dynamic rate control is enabled for a 10 Gb/s Ethernet
        interface to SONET/SDH OC192/STM64.";
    }
  }
}
default disabled;
description
  "Allowed values for dynamic-rate-control.";
reference
  "IEEE Std 802.3, 4.4.2 ipgStretchRatio and 30.3.1.1.34
  aRateControlStatus";
```

IEEE Std 802.3.2-2019  
IEEE Standard for Ethernet YANG Data Model Definitions

```

}

augment "/if:interfaces/if:interface/ieee802-eth-if:ethernet" {
  when "derived-from-or-self(..if:type, 'ianaift:ethernetCsmacd')
    and ieee802-eth-if:duplex = 'half'" {
    description
      "Applies to half-duplex Ethernet interfaces.";
  }
}

description
  "Augment with Ethernet interface configuration parameters
  for half-duplex operation.";

leaf dynamic-rate-control {
  if-feature "dynamic-rate-control";
  type dynamic-rate-control-type;
  description
    "Enables dynamic rate control and specifies what speed (data rate)
    the dynamic rate control is operating at. The value of this attribute
    is constrained by the MAC data rate and hardware support.
    The default value is implementation-dependent.";
  reference
    "IEEE Std 802.3, 30.3.1.1.34 aRateControlStatus";
}
}

augment "/if:interfaces/if:interface/ieee802-eth-if:ethernet/" +
  "ieee802-eth-if:capabilities"{
  when "derived-from-or-self(..if:type,
    'ianaift:ethernetCsmacd') and ..if:duplex = 'half'" {
    description "Applies to half-duplex Ethernet interfaces";
  }
}

description
  "Augment with configuration capabilities for half-duplex
  Ethernet interface.";

leaf dynamic-rate-control-supported {
  if-feature "dynamic-rate-control";
  type boolean;
  default false;
  description
    "Indicates whether the Ethernet interface supports lowering
    the average data rate of the MAC sublayer, with frame
    granularity, by using Rate Control to dynamically increase
    the inter-packet gap.
    Only valid for Ethernet interfaces operating at speeds (data rates)
    above 1000 Mb/s.";
  reference
    "IEEE Std 802.3, 30.3.1.1.33 aRateControlAbility";
}
}

augment "/if:interfaces/if:interface/ieee802-eth-if:ethernet/" +
  "ieee802-eth-if:statistics/ieee802-eth-if:frame" {
  when "derived-from-or-self(..if:type,
    'ianaift:ethernetCsmacd') and ..if:duplex = 'half'" {
    description
      "Applies to half-duplex Ethernet interfaces.";
  }
}

```

```

}
description
  "Augment with statistics for half-duplex Ethernet interface.";

container "csma-cd" {
  if-feature "csma-cd";
  description
    "Holds counters that are specific to CDMA/CD half-duplex
    operation of Ethernet interfaces.
    Discontinuities in the values of the counters in this
    container can occur at re-initialization of the management
    system, and at other times as indicated by the value of the
    'discontinuity-time' leaf defined in the ietf-interfaces
    YANG module (IETF RFC 8343).";

leaf in-errors-sqe-test {
  type yang:counter64;
  units errors;
  description
    "A count of times that the SQE TEST ERROR is received on a
    particular interface. The SQE TEST ERROR is set in
    accordance with the rules for verification of the SQE
    detection mechanism in the PLS Carrier Sense Function as
    described in IEEE Std 802.3, 7.2.4.6.
    This counter does not increment on Ethernet interfaces
    operating at speeds (data rates) greater than 10 Mb/s, or on
    Ethernet interfaces operating in full-duplex mode.
    Discontinuities in the value of this counter can occur at
    re-initialization of the management system, and at other
    times as indicated by the value of the
    'discontinuity-time' leaf defined in the ietf-interfaces
    YANG module (IETF RFC 8343).";
  reference
    "IEEE Std 802.3, 7.2.4.6, and 30.3.2.1.4 aSQETestErrors";
}

leaf out-frames-collision-single {
  type yang:counter64;
  units frames;
  description
    "A count of frames that are involved in a single collision,
    and are subsequently transmitted successfully. A frame
    that is counted by an instance of this object is also
    counted by the corresponding instance of either
    'out-unicast-frames', 'out-broadcast-frames', or
    'out-multicast-frames', and is not counted by the
    corresponding instance of the
    'out-frames-collision-multiple'.

    This counter does not increment when the Ethernet
    interface is operating in full-duplex mode.
    Discontinuities in the value of this counter can occur at
    re-initialization of the management system, and at other
    times as indicated by the value of the
    'discontinuity-time' leaf defined in the ietf-interfaces
    YANG module (IETF RFC 8343).";
  reference
    "IEEE Std 802.3, 30.3.1.1.3 aSingleCollisionFrames";
}

```

IEEE Std 802.3.2-2019  
IEEE Standard for Ethernet YANG Data Model Definitions

```
leaf out-frames-collision-multiple {
  type yang:counter64;
  units frames;
  description
    "A count of frames that are involved in multiple
    collisions, and are subsequently transmitted
    successfully. A frame that is counted by an instance of
    this object is also counted by the corresponding instance
    of either 'out-unicast-frames', 'out-broadcast-frames', or
    'out-multicast-frames', and is not counted by the
    corresponding instance of the 'out-frames-collision-single'.
    This counter does not increment when the Ethernet
    interface is operating in full-duplex mode.
    Discontinuities in the value of this counter can occur at
    re-initialization of the management system, and at other
    times as indicated by the value of the
    'discontinuity-time' leaf defined in the ietf-interfaces
    YANG module (IETF RFC 8343).";
  reference
    "IEEE Std 802.3, 30.3.1.1.4 aMultipleCollisionFrames";
}

leaf out-frames-deferred {
  type yang:counter64;
  units frames;
  description
    "A count of frames for which the first transmission attempt
    on a particular Ethernet interface is delayed because the
    medium is busy.
    A deferred frame that is not subject to any number of
    collisions is not counted by an instance of
    'out-frames-collision-single' or
    'out-frames-collision-multiple' objects.
    This counter does not increment when the Ethernet
    interface is operating in full-duplex mode.
    Discontinuities in the value of this counter can occur at
    re-initialization of the management system, and at other
    times as indicated by the value of the
    'discontinuity-time' leaf defined in the ietf-interfaces
    YANG module (IETF RFC 8343).";
  reference
    "IEEE Std 802.3, 30.3.1.1.9 aFramesWithDeferredXmissions";
}

leaf out-frames-collisions-excessive {
  type yang:counter64;
  units frames;
  description
    "A count of frames for which transmission on a particular
    Ethernet interface fails due to excessive collisions.

    This counter does not increment when the Ethernet
    interface is operating in full-duplex mode.
    Discontinuities in the value of this counter can occur at
    re-initialization of the management system, and at other
    times as indicated by the value of the
    'discontinuity-time' leaf defined in the ietf-interfaces
    YANG module (IETF RFC 8343).";
```

```

reference
  "IEEE Std 802.3, 30.3.1.1.11 aFramesAbortedDueToXSColls";
}

leaf out-collisions-late {
  type yang:counter64;
  units collisions;
  description
    "The number of times that a collision is detected on a
    particular Ethernet interface later than one slotTime into
    the transmission of a packet.
    A (late) collision included in a count represented by an
    instance of this object is also considered as a (generic)
    collision for purposes of other collision-related
    statistics.
    This counter does not increment when the Ethernet
    interface is operating in full-duplex mode.
    Discontinuities in the value of this counter can occur at
    re-initialization of the management system, and at other
    times as indicated by the value of the
    'discontinuity-time' leaf defined in the ietf-interfaces
    YANG module (IETF RFC 8343).";
  reference
    "IEEE Std 802.3, 30.3.1.1.10 aLateCollisions";
}

leaf out-errors-carrier-sense {
  type yang:counter64;
  units errors;
  description
    "The number of times that the carrier sense condition was
    lost or never asserted when attempting to transmit a frame
    on a particular Ethernet interface.
    The count represented by an instance of this object is
    incremented at most once per transmission attempt, even if
    the carrier sense condition fluctuates during a
    transmission attempt.
    This counter does not increment when the Ethernet
    interface is operating in full-duplex mode.
    Discontinuities in the value of this counter can occur at
    re-initialization of the management system, and at other
    times as indicated by the value of the
    'discontinuity-time' leaf defined in the ietf-interfaces
    YANG module (IETF RFC 8343).";
  reference
    "IEEE Std 802.3, 30.3.1.1.13 aCarrierSenseErrors";
}

list collision-histogram {
  key collision-count;
  description
    "A collection of collision histograms for a particular
    interface.";
  reference
    "IEEE Std 802.3, 30.3.1.1.30 aCollisionFrames";
  leaf collision-count {
    type yang:counter64;
    units collisions;
    description

```



## 6. YANG module for Ethernet data terminal equipment (DTE) power via medium dependent interface (MDI) and Power over Data Lines (PoDL)

### 6.1 Introduction

This clause defines a YANG module to manage power via MDI Power Sourcing Equipment (PSE) and Power over Data Line (PoDL) PSE.

IEEE Std 802.3 defines the hardware registers that allow management interfaces to be built for a DTE Power via MDI and Power over Data Line device. The YANG module defined in this clause extends the Ethernet-interface YANG data modules defined in Clause 5 with the management objects required for the management of PoE and PoDL devices and ports.

### 6.2 YANG module structure

The *ieee802-ethernet-pse* YANG module of this clause is focused on the configuration and monitoring of the Power over Ethernet (PoE) function defined in IEEE Std 802.3, including power via MDI, as well as Power over Data Line which can also be considered as the single pair PoE. The module augments the *ieee802-ethernet-interface* YANG module with attributes for the PoE function. The module is partitioned into two major containers.

The PoE PSE container describes a multi-pair PSE, while the PoDL PSE describes a single-pair PSE.

### 6.3 Security considerations for Ethernet data terminal equipment (DTE) power via medium dependent interface (MDI) and Power over Data Line Module

There are a number of data nodes defined in this YANG module that are configurable as read-write. Such data nodes may be considered sensitive or vulnerable in some network environments. The support for configuration operations in a non-secure environment without proper protection can have a negative effect on network operations.

Setting the following data nodes to incorrect values can result in improper operation of the PSE, including the possibility that the Powered Device (PD) does not receive power from the PSE port:

- pse-enable
- powering-pairs

Some of the readable operational states in this module may be considered sensitive or vulnerable in some network environments. These are as follows:

- pairs-control-ability
- classifications
- pd-power-class
- pse-type
- detected-pd-type

It is thus important to control GET access to these data nodes and to possibly encrypt their values when sending them over the network.

### 6.4 Mapping of IEEE Std 802.3, Clause 30 managed objects

This subclause contains the mapping between YANG data nodes included in *ieee802-ethernet-pse* (see Table 6-1) YANG module, managed objects, and attributes defined in IEEE Std 802.3, Clause 30.

Table 6-1—Mapping between IEEE Std 802.3, Clause 30 managed objects and ieee802-ethernet-pse YANG data nodes

IEEE Std 802.3, Clause 30		Corresponding ieee802-ethernet-pse YANG data nodes			
Managed object(s)	Attribute(s)	Reference	Container(s)	Data node(s)	R/W
N/A	N/A		interfaces/interface/ethernet/pse	supported-pse-type	R
oPSE	aPSEAdminState	30.9.1	interfaces/interface/ethernet/pse/multi-pair	pse-enable	R
	aPSEPowerPairs			powering-pairs	R/W
	aPSEPowerPairsControlAbility			pairs-control-ability	R
	aPSEPowerDetectionStatus			detection-status	R
	aPSEPowerClassification			classifications	R
	aPSEActualPower			actual-power	R
	aPSEPowerAccuracy			power-accuracy	R
	aPSEInvalidSignatureCounter			invalid-signature	R
	aPSEPowerDeniedCounter			power-denied	R
	aPSEOverLoadCounter			overload	R
	aPSEShortCounter			short	R
	aPSEMPSAbsentCounter			mmps-absent	R
	aPSECumulativeEnergy			cumulative-energy	R

IECNG.COM : Click to view the full PDF of ISO/IEC/IEEE 8802-3-2:2021

Table 6-1—Mapping between IEEE Std 802.3, Clause 30 managed objects and ieee802-ethernet-pse YANG data nodes (continued)

IEEE Std 802.3, Clause 30		Reference	Corresponding <i>ieee802-ethernet-pse</i> YANG data nodes			
Managed object(s)	Attribute(s)		Container(s)	Data node(s)		
oPoDLPSE	aPoDLPSEAdminState	30.15	interfaces/interface/ethernet/pse/single-pair	pse-enable	R	
	aPoDLPSEPowerDetectionStatus			detection-status	R	
	aPoDLPSEType			podl-type	R	
	aPoDLPSEDetectedPDType			detected-pd-type	R	
	aPoDLPSEDetectedPDPowerClass			pd-power-class	R	
	aPoDLPSEActualPower			actual-power	R	
	aPoDLPSEPowerAccuracy			power-accuracy	R	
	aPoDLPSEInvalidSignatureCounter			interfaces/interface/ethernet/pse/single-pair/statistics	invalid-signature	R
	aPoDLPSEInvalidClassCounter				invalid-class	R
	aPoDLPSEPowerDeniedCounter			power-denied	R	
	aPoDLPSEOverLoadCounter			overload	R	
	aPoDLPSEMaintainFullVoltageSignatureAbsentCounter			fvs-absent	R	
	aPoDLPSECumulativeEnergy			cumulative-energy	R	

## 6.5 YANG module definition<sup>7</sup>

The YANG module tree hierarchy uses terms defined in IETF RFC 8407.

### 6.5.1 Tree hierarchy

```

module: ieee802-ethernet-pse
  augment /if:interfaces/if:interface/ieee802-eth-if:ethernet:
    +--rw pse
      +--ro supported-pse-type?  identityref
      +--rw multi-pair!
        | +--rw pse-enable?      boolean
        | +--rw powering-pairs?  identityref
        | +--ro pairs-control-ability?  boolean
        | +--ro detection-status?  multi-pair-detection-state
        | +--ro classifications?  power-class
        | +--ro statistics
        | | +--ro power-denied?    yang:counter64
        | | +--ro invalid-signature?  yang:counter64
        | | +--ro mps-absent?      yang:counter64
        | | +--ro overload?       yang:counter64
        | | +--ro short?          yang:counter64
        | | +--ro cumulative-energy? yang:counter64
        | +--ro actual-power?     decimal64
        | +--ro power-accuracy?   int64
      +--rw single-pair!
        +--rw pse-enable?      boolean
        +--ro detection-status?  single-pair-detection-state
        +--ro podl-type?       enumeration
        +--ro detected-pd-type? enumeration
        +--ro pd-power-class?  power-class
        +--ro statistics
        | +--ro power-denied?    yang:counter64
        | +--ro invalid-signature?  yang:counter64
        | +--ro invalid-class?    yang:counter64
        | +--ro overload?       yang:counter64
        | +--ro fvs-absence?     yang:counter64
        | +--ro cumulative-energy? yang:counter64
        +--ro actual-power?     decimal64
        +--ro power-accuracy?   int64

```

<sup>7</sup>Copyright release for YANG modules: Users of this standard may freely reproduce the YANG module contained in this subclause so that it can be used for its intended purpose.

## 6.5.2 YANG module

In the following YANG module definition, should any discrepancy between the text of the description for individual YANG nodes and the corresponding definition in 6.2 through 6.5 of this clause occur, the definitions and mappings in 6.5 shall take precedence.

An ASCII text version of the YANG module can be found at the following URL:<sup>8</sup> <https://github.com/YangModels/yang/tree/master/standard/ieee/published/802.3>.

```

module ieee802-ethernet-pse{
  yang-version 1.1;
  namespace "urn:ieee:std:802.3:yang:ieee802-ethernet-pse";
  prefix ieee802-pse;

  revision 2019-06-21 {
    description "Initial revision.";
  }

  import ietf-interfaces {
    prefix "if";
    reference "IETF RFC 8343";
  }

  import ietf-yang-types {
    prefix yang;
    reference "IETF RFC 6991";
  }

  import ieee802-ethernet-interface {
    prefix ieee802-eth-if;
  }

  organization
    "IEEE 802.3 Ethernet Working Group
    Web URL: http://www.ieee802.org/3/";

  contact
    "Web URL: http://www.ieee802.org/3/";

  description
    "This module contains YANG definitions for configuring and
    managing ports with Power Over Ethernet feature defined by
    IEEE 802.3. It provides functionality roughly equivalent to
    that of the POWER-ETHERNET-MIB defined in IETF RFC 3621.";

  reference
    "IEEE Std 802.3-2018, unless dated explicitly";

  typedef multi-pair-detection-state {
    type enumeration {
      enum disabled {
        value 1;
      }
    }
  }
}

```

<sup>8</sup>Copyright release for YANG modules: Users of this standard may freely reproduce the YANG module contained in this subclause so that it can be used for its intended purpose.

IEEE Std 802.3.2-2019  
IEEE Standard for Ethernet YANG Data Model Definitions

```

    description "PSE disabled.";
  }
  enum searching {
    value 2;
    description "PSE is searching.";
  }
  enum deliveringPower {
    value 3;
    description "PSE is delivering power.";
  }
  enum fault {
    value 4;
    description "PSE fault detected.";
  }
  enum test {
    value 5;
    description "PSE test mode.";
  }
  enum otherFault {
    value 6;
    description "PSE implementation specific fault detected.";
  }
}
description
  "Detection state of a multi-pair PSE.";
reference
  "IEEE Std 802.3, 30.9.1.1.5";
}

typedef single-pair-detection-state{
  type enumeration {
    enum unknown {
      value 1;
      description "True detection state unknown.";
    }
    enum disabled {
      value 2;
      description "PoDL PSE is disabled.";
    }
    enum searching {
      value 3;
      description "PoDL PSE is searching.";
    }
    enum deliveringPower {
      value 4;
      description "PoDL PSE is delivering power.";
    }
    enum sleep {
      value 5;
      description "PoDL PSE is in sleep state.";
    }
    enum idle {
      value 6;
      description "PoDL PSE is idle.";
    }
  }
}

```

```
    }
    enum error {
        value 7;
        description "PoDL PSE error.";
    }
}

description
    "Detection state of a PoDL PSE.";
reference
    "IEEE Std 802.3, 30.15.1.1.3";
}

typedef power-class {
    type enumeration {
        enum class0 {
            value 1;
            description "Class 0";
        }
        enum class1 {
            value 2;
            description "Class 1";
        }
        enum class2 {
            value 3;
            description "Class 2";
        }
        enum class3 {
            value 4;
            description "Class 3";
        }
        enum class4 {
            value 5;
            description "Class 4";
        }
        enum class5 {
            value 6;
            description "Class 5 (for PoDL-only)";
        }
        enum class6 {
            value 7;
            description "Class 6 (for PoDL-only)";
        }
        enum class7 {
            value 8;
            description "Class 7 (for PoDL-only)";
        }
        enum class8 {
            value 9;
            description "Class 8 (for PoDL-only)";
        }
        enum class9 {
            value 10;
            description "Class 9 (for PoDL-only)";
        }
    }
}
```

```

    }
    enum unknown {
        value 11;
        description
            "Initializing, true Power Class not yet known
            (only for PoDL PSE).";
    }
}
description
    "Power class.";
reference
    "IEEE Std 802.3, 30.9.1.1.6 aPSEPowerClassification and
    IEEE Std 802.3, 30.15.1.1.6 aPoDLPSEDetectedPDPowerClass.";
}

identity pse-type {
    description "Base type for PSE.";
}

identity multi-pair {
    base pse-type;
    description "PSE supports IEEE Std 802.3, Clause 33.";
}

identity single-pair {
    base pse-type;
    description "PSE support IEEE Std 802.3, Clause 104.";
}

identity powering-pairs {
    description "Base type for powering pairs.";
}

identity signal {
    base powering-pairs;
    description "The signal pair is in use.";
}

identity spare {
    base powering-pairs;
    description "The spare pair is in use.";
}

augment "/if:interfaces/if:interface/ieee802-eth-if:ethernet" {
    description
        "Augments ethernet interface configuration model with
        nodes specific to DTE Power via MDI devices and ports";

    container pse {
        description
            "DTE Power via MDI port configuration";
        reference
            "IEEE Std 802.3, 30.9.1 PoE PSE & IEEE Std 802.3, 30.15.1 PoDL
            PSE";

        leaf supported-pse-type {

```

```

type identityref {
  base ieee802-pse:pse-type ;
}
config false;
description
  "PSE may support IEEE Std 802.3, Clause 33 or
  IEEE Std 802.3, Clause 104.";
}

container multi-pair {
  presence "PSE port supports IEEE Std 802.3, Clause 33.";

  description
    "PSE port configuration in IEEE Std 802.3, 30.9.1.";

  leaf pse-enable {
    type boolean;
    default false;
    description
      "When true enables the PSE function on the interface,
      when false disables the PSE function on the interface.";
    reference
      "IEEE Std 802.3, 30.9.1.1.2 aPSEAdminState";
  }

  leaf powering-pairs {
    type identityref{
      base powering-pairs;
    }
    description
      "Describes or controls the PSE pairs in use. If the value of
      pairs-control-ability is true, this object is
      writeable.";
    reference
      "IEEE Std 802.3, 30.9.1.1.4 aPSEPowerPairs";
  }

  leaf pairs-control-ability {
    type boolean;
    default true;
    config false;
    description
      "Describes the ability to control switching the
      power sourcing pins of the PSE.";
    reference
      "IEEE Std 802.3, 30.9.1.1.3 aPSEPowerPairsControlAbility";
  }

  leaf detection-status {
    type multi-pair-detection-state;
    config false;
    description
      "Describes the operational status of the port

```

IEEE Std 802.3.2-2019  
IEEE Standard for Ethernet YANG Data Model Definitions

```

    PD detection.";
  reference
    "IEEE Std 802.3, 30.9.1.1.5 aPSEPowerDetectionStatus";
}

leaf classifications {
  when "../detection-status = 'deliveringPower'" {
    description
      "This node only applies when the detection status is
      delivering power.";
  }
  type power-class;
  config false;
  description
    "The power class of the PSE port.";
  reference
    "IEEE Std 802.3, 30.9.1.1.6 aPSEPowerClassification";
}

container statistics {
  config false;
  description
    "statistics information of the multi-pair port.";

  leaf power-denied {
    type yang:counter64;
    description
      "This counter is incremented when the PSE state diagram
      enters the POWER_DENIED state, per IEEE Std 802.3,
      Figure 33-9.";
    reference
      "IEEE Std 802.3, 30.9.1.1.8 aPSEPowerDeniedCounter";
  }

  leaf invalid-signature {
    type yang:counter64;
    description
      "This counter is incremented when the PSE state diagram
      enters the SIGNATURE_INVALID state per IEEE Std 802.3,
      Figure 33-9.";
    reference
      "IEEE Std 802.3, 30.9.1.1.7 aPSEInvalidSignatureCounter";
  }

  leaf mps-absent {
    type yang:counter64;
    description
      "This counter is incremented when the PSE
      transitions directly from the POWER_ON state to the
      IDLE state due to tmpdo_timer_done being asserted,
      per IEEE Std 802.3, Figure 33-9.";
    reference
      "IEEE Std 802.3, 30.9.1.1.11 aPSEMPSAbsentCounter";
  }
}

```

```
leaf overload {
  type yang:counter64;
  description
    "This counter is incremented when the PSE state diagram
    enters the ERROR_DELAY state due to the ovld_detected
    variable being TRUE, per IEEE Std 802.3, Figure 33-9.";
  reference
    "IEEE Std 802.3, 30.9.1.1.9 aPSEOverLoadCounter";
}

leaf short {
  type yang:counter64;
  description
    "This counter is incremented when the PSE state diagram
    enters the ERROR_DELAY state due to the short_detected
    variable being TRUE, per IEEE Std 802.3, Figure 33-9.";
  reference
    "IEEE Std 802.3, 30.9.1.1.10 aPSEShortCounter";
}

leaf cumulative-energy {
  type yang:counter64;
  units millijoules;
  description
    "The cumulative energy supplied by the PSE as measured at
    the MDI in millijoules.";
  reference
    "IEEE Std 802.3, 30.9.1.1.14 aPSECumulativeEnergy";
}

}

leaf actual-power {
  type decimal64 {
    fraction-digits 4;
  }
  units milliwatts;
  config false;
  description
    "The actual power drawn by a PD over the port.";
  reference
    "IEEE Std 802.3, 30.9.1.1.12 aPSEActualPower";
}

leaf power-accuracy {
  type int64;
  units milliwatts;
  config false;
  description
    "An integer value indicating the accuracy
    associated with power-accuracy in +/- milliwatts.";
```

IEEE Std 802.3.2-2019  
IEEE Standard for Ethernet YANG Data Model Definitions

```

    reference
      "IEEE Std 802.3, 30.9.1.1.13 aPSEPowerAccuracy";
  }
}

container single-pair {
  presence "PSE port working in PoDL.";

  description
    "PoDL PSE configuration as defined in
     IEEE Std 802.3, 30.15.1.";

  leaf pse-enable {
    type boolean;
    default false;
    description
      "When true enables the PSE function on the interface,
       when false disables the PSE function on the interface.";
    reference
      "IEEE Std 802.3, 30.15.1.1.2 aPoDLPSEAdminState";
  }

  leaf detection-status {
    type single-pair-detection-state;
    config false;
    description
      "Indicates the current status of the PoDL PSE.";
    reference
      "IEEE Std 802.3, 30.15.1.1.3 aPoDLPSEPowerDetectionStatus";
  }

  leaf podl-type {
    type enumeration {
      enum unknown {
        description "Unknown PSE type.";
      }
      enum typeA {
        description "TypeA";
      }
      enum typeB {
        description "TypeB";
      }
      enum typeC {
        description "TypeC";
      }
      enum typeD {
        description "TypeD";
      }
    }
    config false;
    description "PSE type specified in IEEE Std 802.3, 104.4.1.";
  }
}

```

```

leaf detected-pd-type {
  when "../detection-status = 'deliveringPower'" {
    description
      "This node only applies when the detection status is
      delivering power.";
  }

  type enumeration {
    enum unknown {
      description "Unknown";
    }
    enum typeA {
      description "TypeA";
    }
    enum typeB {
      description "TypeB";
    }
    enum typeC {
      description "TypeC";
    }
    enum typeD {
      description "TypeD";
    }
  }
  config false;
  description
    "Indicates the Type of the detected PoDL PD as specified in
    IEEE Std 802.3, 104.5.1";

  reference
    "IEEE Std 802.3, 30.15.1.1.5 aPoDLPSEDetectedPDType";
}

leaf pd-power-class {

  when "../detection-status = 'deliveringPower'" {
    description
      "This node only applies when the detection status is
      delivering power.";
  }

  type power-class;
  config false;
  description
    "Power class of the PD detected on the PSE port.";
  reference
    "IEEE Std 802.3, 30.15.1.1.6 aPoDLPSEDetectedPDPowerClass";
}

container statistics {
  config false;
  description "Statistics information of the single-pair PSE";

  leaf power-denied {

```

IEEE Std 802.3.2-2019  
IEEE Standard for Ethernet YANG Data Model Definitions

```

type yang:counter64;
description
  "This counter is incremented when the PoDL PSE state
  diagram variable power_available transitions from true
  to false (see IEEE Std 802.3, 104.4.3.3).";
reference
  "IEEE Std 802.3, 30.15.1.1.9 aPoDLPSEPowerDeniedCounter";
}

leaf invalid-signature {
  type yang:counter64;
  description
    "This counter is incremented when the PSE state diagram
    enters the SIGNATURE_INVALID state per
    IEEE Std 802.3, Figure 33-9.";
  reference
    "IEEE Std 802.3, 30.15.1.1.7
    aPoDLPSEInvalidSignatureCounter";
}

leaf invalid-class {
  type yang:counter64;
  description
    "This counter is incremented when the PoDL PSE state
    diagram variable tclass_timer_done transitions from false
    to true or when the valid_class variable transitions from
    true to false (see IEEE Std 802.3, 104.4.3.3).";

  reference
    "IEEE Std 802.3, 30.15.1.1.8 aPoDLPSEInvalidClassCounter";
}

leaf overload {
  type yang:counter64;
  description
    "This counter is incremented when the PSE state diagram
    variable overload_held transitions from false to true
    (see IEEE Std 802.3, 104.4.3.3).";
  reference
    "IEEE Std 802.3, 30.15.1.1.10 aPoDLPSEOverLoadCounter";
}

leaf fvs-absence {
  type yang:counter64;
  description
    "Maintain Full Voltage Signature absent counter.
    This counter is incremented when the PoDL PSE state
    diagram variable mfvs_timeout transitions from false to
    true (see IEEE Std 802.3, 104.4.3.3).";

  reference
    "IEEE Std 802.3, 30.15.1.1.11
    aPoDLPSEMaintainFullVoltageSignatureAbsentCounter";
}

```

```
leaf cumulative-energy {
  type yang:counter64;
  units millijoules;
  description
    "A count of the cumulative energy supplied by the PoDL
    PSE, measured at the MDI, and expressed in units of
    millijoules.";
  reference
    "IEEE Std 802.3, 30.15.1.1.14 aPoDLPSECumulativeEnergy";
}

leaf actual-power {
  type decimal64 {
    fraction-digits 4 ;
  }

  units milliwatts;
  config false;
  description
    "An integer value indicating present (actual) power being
    supplied by the PoDL PSE as measured at the MDI in
    milliwatts.";
  reference
    "IEEE Std 802.3, 30.15.1.1.12 aPoDLPSEActualPower";
}

leaf power-accuracy {
  type int64;
  units milliwatts;
  config false;
  description
    "A signed integer value indicating the accuracy associated
    with power-accuracy in milliwatts.";
  reference
    "IEEE Std 802.3, 30.15.1.1.13 aPoDLPSEPowerAccuracy";
}
}
}
}
```

## 7. YANG module for Ethernet Passive Optical Network (EPON)

### 7.1 Introduction

This clause defines a YANG module to manage Ethernet Passive Optical Network (EPON).

### 7.2 YANG module structure

The *ieee802-ethernet-pon* YANG module of this clause is focused on the configuration and monitoring of EPON.

#### 7.2.1 Introduction

EPON is defined in IEEE Std 802.3, covering Physical Layers and Media Access Control sublayers. The Passive Optical Network (PON) is comprised of sections of single-mode fiber connected with passive optical splitter/coupler devices, forming a passive optical tree, as shown in Figure 7–1. Individual branches of the PON are terminated with the Optical Line Terminal (OLT) in the Central Office or at remote optical nodes, and Optical Network Units (ONUs) near the subscribers. ONUs can be located either in some remote location (e.g., basement in a multi-dwelling unit) or directly at the subscriber premises. Various types of Customer Premises Equipment (CPE) can be connected to ONUs or even integrated with such devices. Figure 7–1 presents an example PON topology.

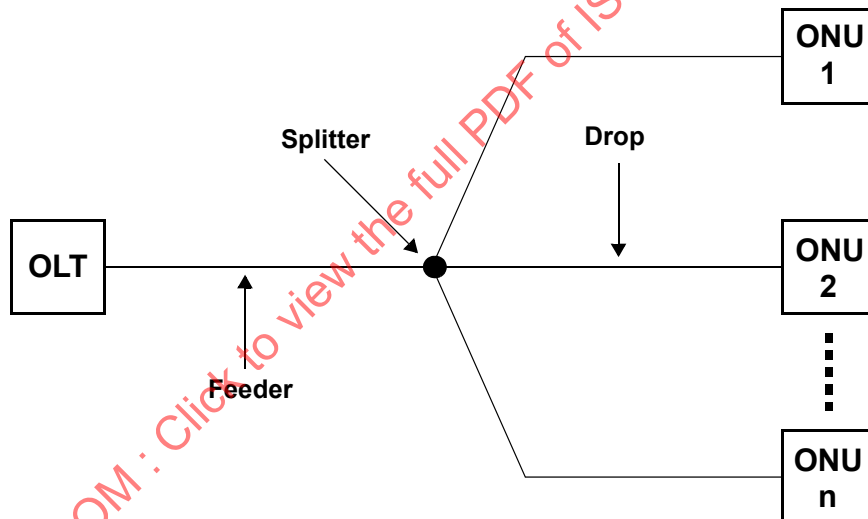

Figure 7–1—PON topology example

The following clauses in IEEE Std 802.3 define 1G-EPON:

- Clause 60: Physical Medium Dependent (PMD) sublayer for 1G-EPON
- Clause 64: MPCP (Multipoint Control Protocol) for 1G-EPON
- Clause 65: Reconciliation Sublayer (RS), Physical Coding Sublayer (PCS), and Physical Media Attachment (PMA) sublayers for 1G-EPON

The following clauses in IEEE Std 802.3 define 10G-EPON:

- Clause 75: PMD sublayer for 10G-EPON
- Clause 76: RS, PCS, and PMA sublayers for 10G-EPON

- Clause 77: MPCP for 10G-EPON

Additionally, IEEE Std 802.3, Clause 30 and Clause 45 are also applicable to EPON.

### 7.2.2 Principles of operation

The EPON specification extended the specification of Gigabit Ethernet (in case of 1G-EPON) or 10 Gigabit Ethernet (in case of 10G-EPON) as described in IEEE Std 802.3. The Ethernet MAC operates at the data rate of 1 Gb/s (in 1G-EPON) or 10 Gb/s (in 10G-EPON) and it is connected to a media dependent interface through the GMII (in 1G-EPON) or XGMII (in 10G-EPON) interface. The EPON PCS layer extended the Ethernet PCS, adding burst-mode operation capabilities and EPON-specific forward error correction (FEC). The following new, EPON-specific layers were added:

- MPCP is placed in the MAC control layer, providing EPON media access, station discovery, and registration protocol.
- Functionality of the reconciliation sublayer (RS) was extended, creating logical links over shared passive optical medium, providing private transmission channels to each of the connected ONU.
- FEC functionality (optional in 1G-EPON, mandatory in 10G-EPON) located in the PCS was added, extending the Ethernet PCS layer, enhancing reach and split performance of the EPON optical link.

Figure 7–2 presents the EPON layering model.

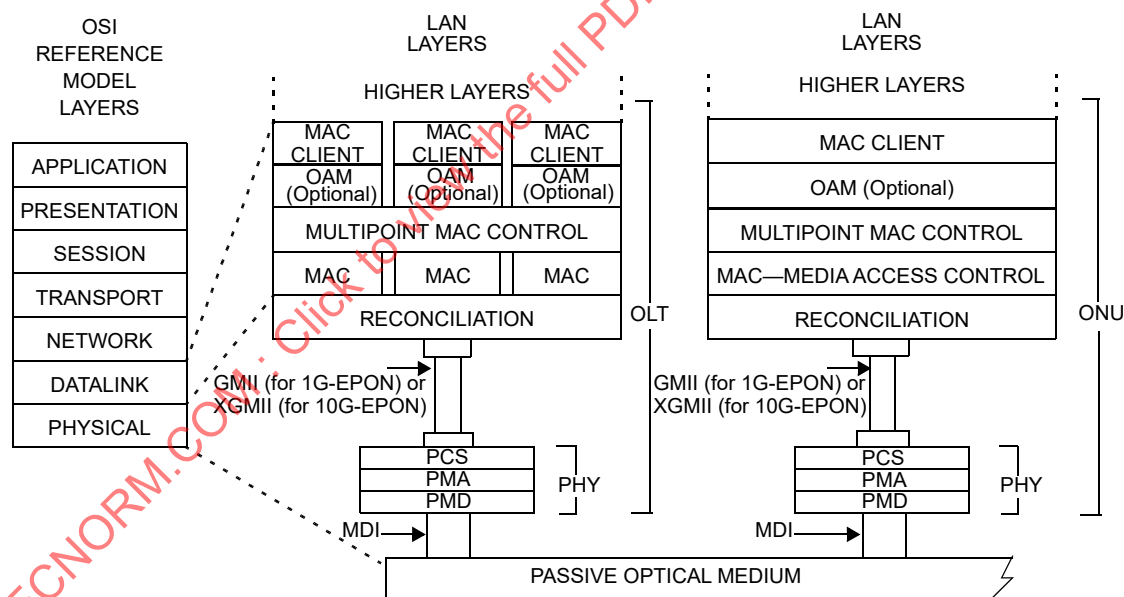

GMII = GIGABIT MEDIA INDEPENDENT INTERFACE  
XGMII = 10GIGABIT MEDIA INDEPENDENT INTERFACE  
MDI = MEDIUM DEPENDENT INTERFACE  
OAM = OPERATIONS, ADMINISTRATION & MAINTENANCE  
OLT = OPTICAL LINE TERMINAL

ONU = OPTICAL NETWORK UNIT  
PCS = PHYSICAL CODING SUBLAYER  
PHY = PHYSICAL LAYER DEVICE  
PMA = PHYSICAL MEDIUM ATTACHMENT  
PMD = PHYSICAL MEDIUM DEPENDENT

Figure 7–2—Relationship of Multipoint MAC Control and the OSI protocol stack

### 7.2.3 Physical media

The physical link in EPON comprises single-mode fiber. The OLT and ONUs are connected through a passive optical network comprising sections of single-mode fiber interconnected with passive splitter/coupler devices.

The term *downstream* denotes transmission from the OLT to all connected ONUs, while the term *upstream* denotes transmission from the connected ONUs (one at the time) to the OLT. Upstream and downstream transmissions are wavelength division multiplexed (WDM) into a single strand of single-mode fiber, sharing the same physical link.

The downstream transmission channel is continuously available to the OLT, thus Time Division Multiplexing (TDM) is used. Transmissions from the OLT arrive at all of the connected ONUs and the individual ONUs filter data from the OLT's transmission based on the logical link identifiers (LLID) assigned to them during the registration and discovery process.

The upstream transmission channel is shared among a number of connected and registered ONUs using time-division multiple access (TDMA). Access to the upstream channel is controlled via the Multipoint Control Protocol (MPCP), where the OLT plays the role of the master and ONUs play the role of slave devices. An ONU upon registration remains silent until registered and once registered, it transmits data towards OLT only when granted a transmission opportunity (slot).

### 7.2.4 PMD specifications

The EPON PMD specifications are based on a wavelength plan defined in IEEE Std 802.3, Clause 60 (1G-EPON) and Clause 75 (10G-EPON). The OLT and ONU optical parameters were derived in part from applicable Ethernet PMD specifications, with the addition of WDM capabilities, and burst mode operation for ONU transmitters and the OLT receiver.

The upstream burst mode operation capability corresponds directly to the TDMA operation in the upstream direction, where queued data is burst from individual ONUs at full data rate for the duration of the allocated transmission period. Once completed, the ONU goes silent and another ONU starts transmitting its data.

### 7.2.5 Principles of the MPCP

The EPON standard comprises a mechanism for media access control, referred to as Multipoint Control Protocol (MPCP). An access network architecture is different from a typical LAN environment, primarily in terms of network provisioning. An access network is an administrated environment, with an operator providing services and subscribers consuming it depending on service provisioning contracts. The operator controls the network, manages traffic and medium access, and enforces the service level agreements. For instance, the available bandwidth is controlled and subscribers may be billed for services. In this sense, the access network (and EPON specifically) requires a media access control protocol that provides a mechanism for station discovery and registration as well as bandwidth provisioning capabilities.

In the MPCP, the OLT is considered to be the master, controlling a series of connected ONUs (slave devices). The OLT manages the network and controls access to network resources from individual slave devices. The MPCP is also used for provisioning upstream channel access to individual slave devices via a MPCPDU pair i.e., GATE and REPORT. The MPCP is part of the MAC control layer and MPCPDUs are considered MAC control messages, carrying a specific Ethertype of 0x8808. These messages are not forwarded outside of the EPON domain and are used to manage the EPON link only.

A concept of time exists in the MPCP in order to schedule the upstream transmission. A timestamp, which is transmitted in the MPCPDUs downstream by the OLT and received by the connected ONUs, is used to synchronize slave devices to the master device clock. This coordinates upstream transmissions from individual

ONUs so that the transmissions arrive at the OLT at the precisely anticipated time, and thus data from different ONUs do not overlap.

The MPCP plane is also used to measure the round-trip time (RTT) for each connected ONU. Each MPCPDU carries a generalized timestamp field, which is filled in by the transmitting station with the current value of its MPCP clock at the time when the given MPCPDU is transmitted. The RTT is measured first during the discovery and registration process and then updated regularly upon each exchange of MPCPDUs between the OLT and one of the ONUs. RTT is used by the OLT bandwidth scheduler to schedule upstream transmission slots for individual ONUs in a non-overlapping manner. The IEEE 802.3 EPON standard provides support for the network diameter (distance between the OLT and the farthest ONU) of nominally up to 20 km, which corresponds to the RTT of approximately 200  $\mu$ s. However, nothing in the standard precludes support for larger network diameters.

The TDMA control is performed using a pair of MPDPUs, namely GATE generated by the OLT to indicate a future transmission opportunity to an ONU and REPORT generated by the ONU with information on the current queue status (bandwidth demand). Internal structure and possible encoding of GATE and REPORT MPCPDUs are defined in IEEE Std 802.3, Clause 64 (for 1G-EPON) and Clause 77 (for 10G-EPON).

A scheduling algorithm at the OLT, which is not defined in IEEE Std 802.3, is responsible for dividing the bandwidth and controlling the transmission delay of each ONU according to its service level agreement. The MPCP defines a closed loop operation in order for this algorithm to be efficient. The MPCP allows the ONUs to report on the amount of bandwidth they require for transmission using a special REPORT message. This allows allocating bandwidth to an ONU only when requested, relying on the statistical burst property of the traffic, and allowing different peak bandwidths for different ONUs at different times; hence, allowing oversubscription of the bandwidth. The REPORT message reports the amount of data waiting in the ONU queues.

In addition, the MPCP defines a protocol of auto-discovery and registration of ONUs.

The MPCP registration process is presented in Figure 7-3, while details are described in IEEE Std 802.3, Clause 64 (for 1G-EPON) and Clause 77 (for 10G-EPON). Note that MPCP for 10G-EPON supports the coexistence mode, i.e., simultaneous operation of 1G-EPON and 10G-EPON devices on the same fiber plant, through time sharing the upstream transmission channel.

A new ONU requests to register during a special upstream window (called Discovery Window), sending the REGISTER\_REQ MPCPDU. More than one ONU may attempt registration during that window, which means that their REGISTER\_REQ MPCPDUs can potentially collide at the OLT receiver, since the ONU-specific RTT is not yet known and transmissions from individual ONUs cannot be scheduled in a non-overlapping manner. A random backoff mechanism was therefore developed and is used to increase the registration success probability.

When the OLT receives a REGISTER\_REQ MPCPDU from an ONU, a decision a non-overlapping on registration is taken and an LLID is assigned to that ONU. Next, the OLT sends a REGISTER MPCPDU to that ONU, informing the given slave device whether it is admitted to network or not. The registration process is completed with the ONU sending REGISTER\_ACK MPCPDU to the OLT, confirming assigned parameters and registration in the network. From that point onward, the OLT can schedule transmissions from that ONU using its LLID and the measured RTT so that its transmissions do not collide with other ONUs.

Additional higher layer protocols may be employed to authenticate the ONU and allow it to participate in the network; however, their specification is outside the scope of IEEE Std 802.3.

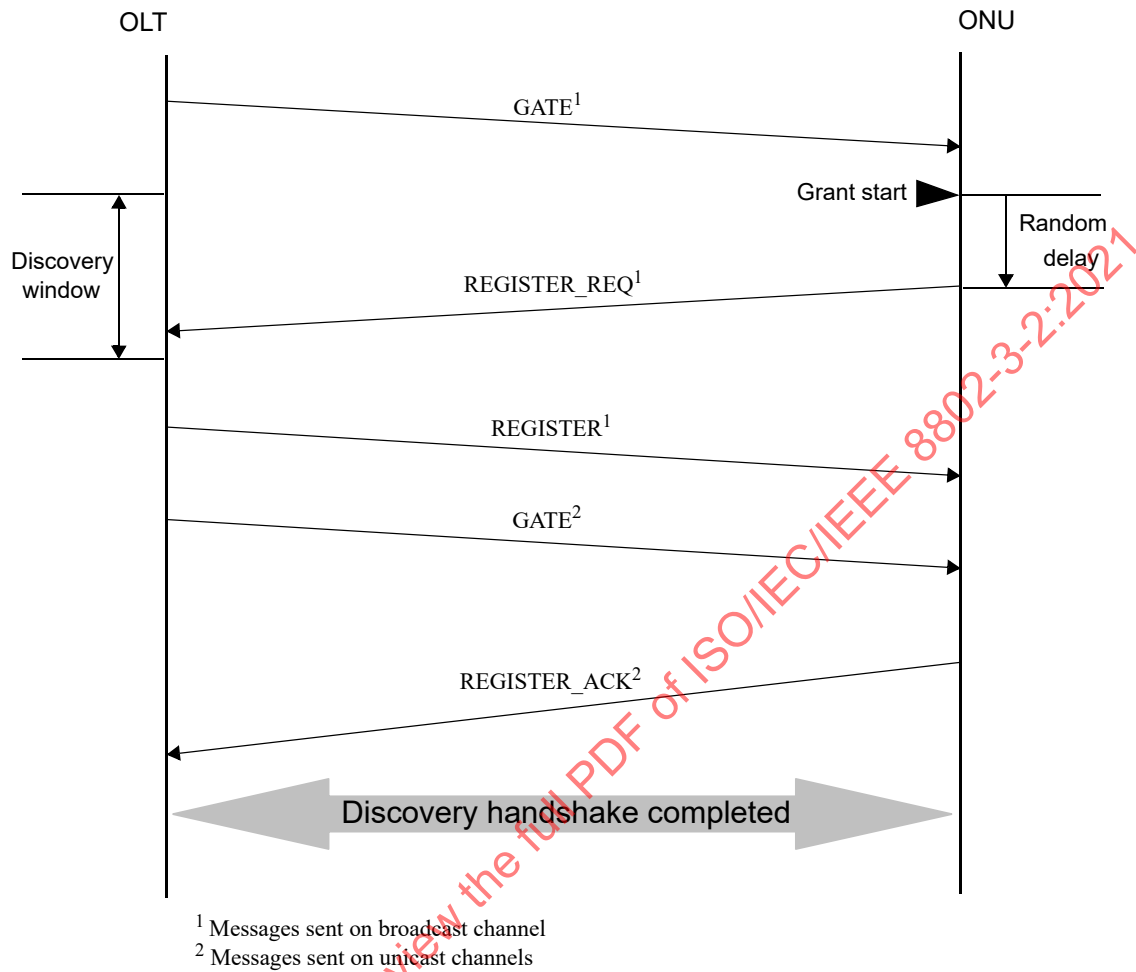

**Figure 7-3—Discovery handshake message exchange**

### 7.2.6 Forward error correction (FEC)

The FEC mechanism is optional for 1G-EPON and is defined to enhance the 1G-EPON link budget. All the passive components of the fiber plant attenuate the optical signal, thus the target distance (network diameter) and the number of supported splits is limited by the available link budget. The optional FEC mechanism increases the available link budget by improving the link BER from  $10^{-4}$  to  $10^{-12}$  (the target BER at the MAC), effectively increasing the target network diameter and/or split ratio. The target use of the increased power budget remains at the sole discretion of the network architects and is out of the scope of IEEE Std 802.3.

The optional FEC used in 1G-EPON is frame-based, meaning that parity information is added at the end of each Ethernet packet. Extra space between individual Ethernet packets is provided by the MAC rate adaptation function, while extra idle symbols were replaced within the FEC function.

The start and end of packet codewords also define the FEC boundaries, and they are outside the FEC protection. They are replaced by a series of symbols to reduce their vulnerability to link errors.

Figure 7–4 presents the structure of an FEC-protected 1G-EPON frame.

The optional FEC function is added to the extended Gigabit Ethernet PCS per 65.2 in IEEE Std 802.3. The added, optional FEC function introduces a fixed delay in receive path and transmit path.

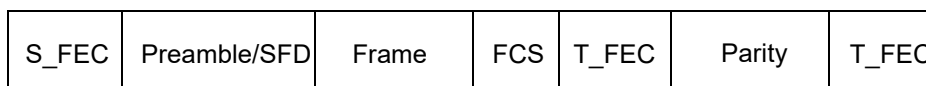

**Figure 7–4—1G-EPON FEC-protected frame**

The FEC mechanism is mandatory for 10G-EPON, and similarly to 1G-EPON – defined to enhance the EPON link budget. The mandatory FEC mechanism increases the available link budget by improving the link BER from  $2 \times 10^{-3}$  to  $10^{-12}$  (the target BER at the MAC), effectively increasing the target network diameter and/or split ratio. The target use of the increased power budget remains at the sole discretion of the network architects and is out of the scope of IEEE Std 802.3. The mandatory FEC used in 10G-EPON is stream-based, meaning that 32 parity symbols are inserted into the bit stream at regular intervals (every 223 information symbols). Details of the FEC encoding process in 10G-EPON are described in IEEE Std 802.3, 76.3.2.4, including the structure of the resulting frame and the resulting bit ordering shown in IEEE Std 802.3, Figure 76-12.

### 7.2.7 Management architecture

All of the EPON layers are accompanied by a management interface that is controlled through mechanisms defined in Clause 30 of IEEE Std 802.3. Since IEEE Std 802.3 specifications may be used for different applications (and hence are extensible), and some of the clauses may be used separately, the management clause allocates a separate package for each independent layer. The structure of the modules follows this separation.

Figure 7–5 presents the relation of the module groups to the individual IEEE Std 802.3 layers.

The association is straightforward for the ONU interface. There is one logical and one physical interface, and a single copy of each layer can be remotely queried by the OLT.

The OLT has a single physical interface and N logical interfaces, one for each logical link connected to an ONU. There is also one logical interface for the single copy broadcast link. Per layering diagram in Figure 7–5, the MAC sublayer is virtually replicated. Therefore, in this clause it was elected that management of logical interfaces is performed in the manner identical to management of any physical interfaces—an interface index is allocated for each one of the logical links, and an additional interface index is allocated for the OLT.

Each row in the tables is indexed according to the ifIndex; specifically, there is a row for each logical link. There are some control objects that are shared and are the same for the logical interfaces (and they should have the same value for each ifIndex), but most of the objects have different values for N+1 logical interfaces at the OLT. This is done for each YANG group. It is different from the EPON layering diagram, which presents the P2MP layer as a single layer, while duplicating the MAC and MAC client layers (please see Figure 7–5). However, from a management perspective, it is more convenient to partition the management of the layers for the logical links, as the atomic managed entity is the logical link. It is also convenient to use the interface index of the logical link for that purpose, as it is already used to index the rows of the logical links at the Interface, MAU, and Ethernet-like interface YANG module.

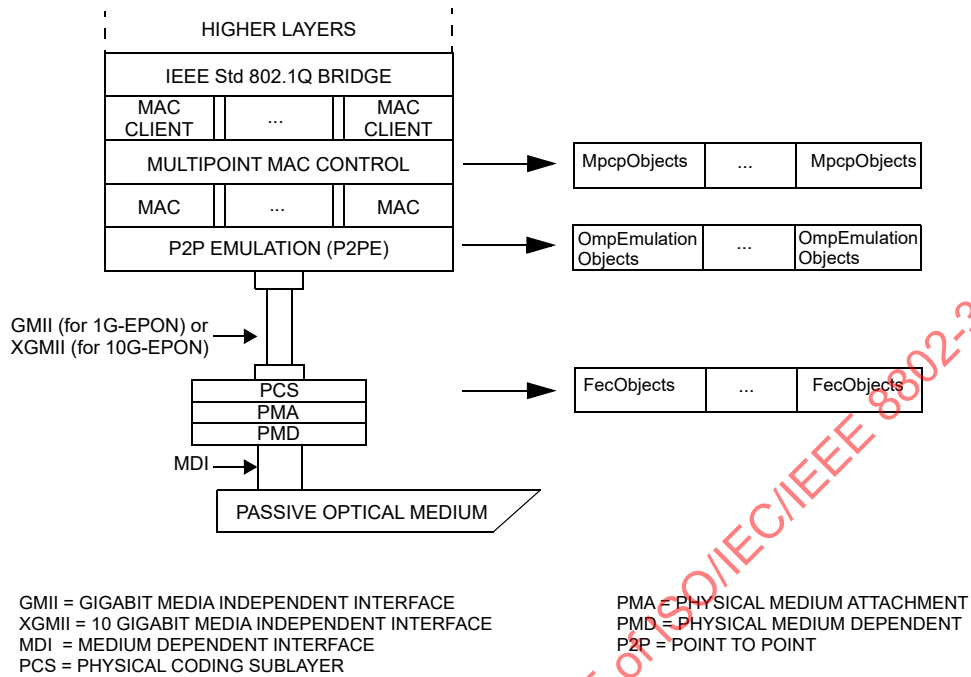

Figure 7-5—Relationship of the YANG module to the EPON sublayers

### 7.3 Mapping of IEEE Std 802.3, Clause 30 managed objects

This sub-clause contains the mapping between YANG data nodes included in *ieee802-ethernet-pon* (see Table 7-1) YANG module, managed objects, and attributes defined in IEEE Std 802.3.1, IEEE8023-DOT3-EPON-MIB.

**Table 7-1—Mapping between IEEE Std 802.3.1, IEEE8023-DOT3-EPON-MIB managed objects and ieee802-ethernet-pon YANG data nodes**

Managed object(s)	IEEE Std 802.3.1, IEEE8023-DOT3-EPON-MIB		Corresponding <i>ieee802-ethernet-pon</i> YANG data nodes	
	Attribute(s)	Container(s)	Data node(s)	R/W
dot3EponFecTable	dot3EponFecMode		fec-mode	R/W
	dot3EponFecPCSCodingViolation	statistics-pon-fec	fec-code-group-violations	R
	dot3EponFecAbility		fec-capability	R
	dot3EponFecCorrectedBlocks	statistics-pon-fec	fec-code-word-corrected-errors	R
	dot3EponFecUncorrectableBlocks	statistics-pon-fec	fec-code-word-uncorrected-errors	R
	dot3EponFecBufferHeadCodingViolation	statistics-pon-fec	fec-buffer-head-coding-violation	R
	dot3MpcpAdminState		mpcp-admin-state	R/W
	dot3MpcpMode		mpcp-mode	R
dot3MpcpControlTable	dot3MpcpLinkID		mpcp-logical-link-id	R
	dot3MpcpRemoteMACAddress		mpcp-remote-mac-address	R
	dot3MpcpRegistrationState		mpcp-logical-link-state	R
	dot3MpcpSyncTime		mpcp-sync-time	R
	dot3MpcpTransmitElapsed		mpcp-elapsed-time-out	R
	dot3MpcpReceiveElapsed		mpcp-elapsed-time-in	R
	dot3MpcpRoundTripTime		mpcp-round-trip-time	R
	dot3MpcpMaximumPendingGrants		mpcp-maximum-grant-count	R

Table 7-1—Mapping between IEEE Std 802.3.1, IEEE8023-DOT3-EPON-MIB managed objects and ieee802-ethernet-pon YANG data nodes (continued)

Managed object(s)	IEEE 802.3.1, IEEE8023-DOT3-EPON-MIB Attribute(s)	Corresponding ieee802-ethernet-pon YANG data nodes		
		Container(s)	Data node(s)	R/W
dot3ExtPkgQueueSets Table	dot3QueueSetIndex	mpcp-queue-thresholds	mpcp-queue-set-index	R/W
	dot3ExtPkgObjectReportThreshold	mpcp-queues	mpcp-queue-set-threshold	R/W
	dot3QueueIndex		mpcp-queue-index	R/W
	dot3ExtPkgObjectReportNumThreshold	mpcp-queue-threshold-count	R/W	
	dot3ExtPkgObjectReportMaximumNumThreshold	mpcp-queue-threshold-count-max	R	
	dot3ExtPkgStatTxFramesQueue	in-mpcp-queue-frames	R	
	dot3ExtPkgStatRxFramesQueue	out-mpcp-queue-frames	R	
	dot3ExtPkgStatDroppedFramesQueue	mpcp-queue-frames-drop	R	
	dot3ExtPkgObjectReset	mpcp-logical-link-admin-state	R/W	
	dot3MpcpOperStatus			
dot3ExtPkgControl Table	dot3ExtPkgObjectNumberOfLLIDs		mpcp-logical-link-count	R
	dot3ExtPkgObjectReportMaximumNumQueues		mpcp-maximum-queue-count-per-report	R
dot3RecognizedMulticast-IDs Table	dot3RecognizedMulticastID	multicast-IDs	multicast-ID	R/W

Table 7-1—Mapping between IEEE Std 802.3.1, IEEE8023-DOT3-EPON-MIB managed objects and ieee802-ethernet-pon YANG data nodes (continued)

Managed object(s)	Attribute(s)	Corresponding <i>ieee802-ethernet-pon</i> YANG data nodes		
		Container(s)	Data node(s)	R/W
dot3OmpEmulation Table	dot3OmpEmulationType	statistics-ompe	ompe-mode	R
	dot3OmpEmulationSLDErrors		in-ompe-frames-errored-sld	R
	dot3OmpEmulationCRC8Errors		in-ompe-frames-errored-crc8	R
	dot3OmpEmulationBadLLID		in-ompe-frames-with-bad-llid	R
	dot3OmpEmulationGoodLLID		in-ompe-frames-with-good-llid	R
	dot3OmpEmulationBroadcastBitNotOnuLlid		in-ompe-frames-not-match-onu-llid-broadcast	R
	dot3OmpEmulationOnuLLIDNotBroadcast		in-ompe-frames-match-onu-llid-not-broadcast	R
	dot3OmpEmulationBroadcastBitPlusOnuLlid		in-ompe-frames-match-onu-llid-broadcast	R
	dot3OmpEmulationNotBroadcastBitNotOnuLlid		in-ompe-frames-not-match-onu-llid-not-broadcast	R
			in-ompe-frames	R
			ompe-onu-frames-with-good-llid-good-crc8	
			ompe-olt-frames-with-good-llid-good-crc8	

**Table 7-1—Mapping between IEEE Std 802.3.1, IEEE8023-DOT3-EPON-MIB managed objects and ieee802-ethernet-pon YANG data nodes (continued)**

Managed object(s)	IEEE Std 802.3.1, IEEE8023-DOT3-EPON-MIB Attribute(s)	Corresponding ieee802-ethernet-pon YANG data nodes		
		Container(s)	Data node(s)	R/W
dot3MpcpStat Table	dot3MpcpMACCtrlFramesTransmitted	statistics-mpcp	out-mpcp-mac-ctrl-frames	R
	dot3MpcpMACCtrlFramesReceived		in-mpcp-mac-ctrl-frames	R
	dot3MpcpDiscoveryWindowsSent		mpcp-discovery-window-count	R
	dot3MpcpDiscoveryTimeout		mpcp-discovery-timeout-count	R
	dot3MpcpTxRegRequest		out-mpcp-register-req	R
	dot3MpcpRxRegRequest		in-mpcp-register-req	R
	dot3MpcpTxRegAck		out-mpcp-register-ack	R
	dot3MpcpRxRegAck		in-mpcp-register-ack	R
	dot3MpcpTxReport		out-mpcp-report	R
	dot3MpcpRxReport		in-mpcp-report	R
	dot3MpcpTxGate		out-mpcp-gate	R
	dot3MpcpRxGate		in-mpcp-gate	R
	dot3MpcpTxRegister		out-mpcp-register	R
	dot3MpcpRxRegister		in-mpcp-register	R

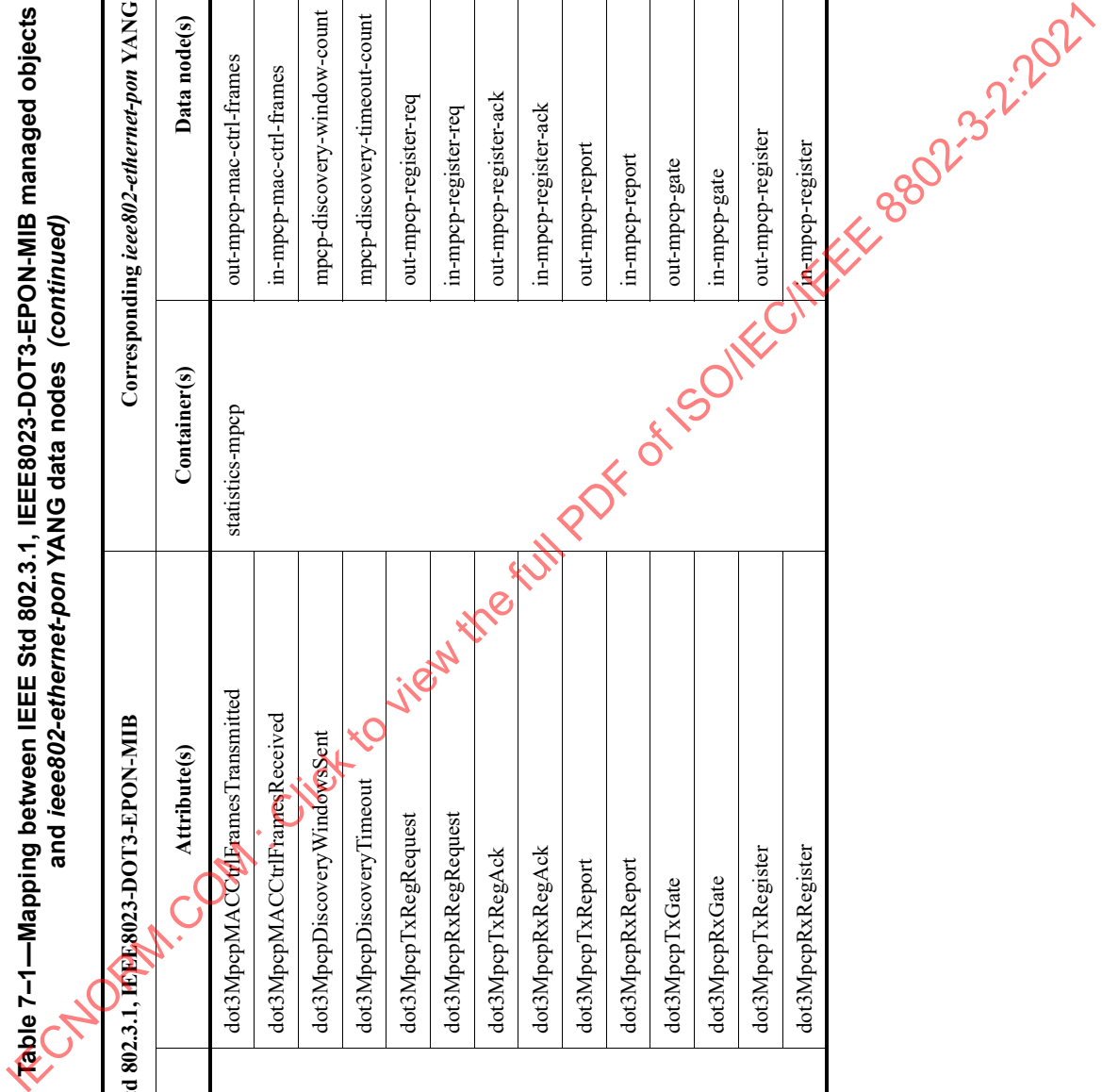

Table 7-1—Mapping between IEEE Std 802.3.1, IEEE8023-DOT3-EPON-MIB managed objects and ieee802-ethernet-pon YANG data nodes (continued)

Managed object(s)	IEEE Std 802.3.1, IEEE8023-DOT3-EPON-MIB Attribute(s)	Corresponding ieee802-ethernet-pon YANG data nodes		
		Container(s)	Data node(s)	
dot3ExtPkgOptIfTable	dot3ExtPkgOptIfLowerInputPowerThreshold	thresholds-trx	in-trx-power-low-threshold	R/W
	dot3ExtPkgOptIfUpperInputPowerThreshold		in-trx-power-high-threshold	R/W
	dot3ExtPkgOptIfLowerOutputPowerThreshold		out-trx-power-low-threshold	R/W
	dot3ExtPkgOptIfUpperOutputPowerThreshold		out-trx-power-high-threshold	R/W
	dot3ExtPkgOptIfSignalDetect		in-trx-power-signal-detect	R
	dot3ExtPkgOptIfInputPower		in-trx-power	R
	dot3ExtPkgOptIfLowInputPower		in-trx-power-low-15-minutes-bin	R
	dot3ExtPkgOptIfHighInputPower		in-trx-power-high-15-minutes-bin	R
	dot3ExtPkgOptIfTransmitEnable		out-trx-power-signal-detect	R/W
	dot3ExtPkgOptIfOutputPower		out-trx-power	R
	dot3ExtPkgOptIfLowOutputPower		out-trx-power-low-15-minutes-bin	R
	dot3ExtPkgOptIfHighOutputPower		out-trx-power-high-15-minutes-bin	R
	dot3ExtPkgOptIfSuspectedFlag			trx-data-reliable

## 7.4 YANG module definition<sup>9</sup>

The YANG module tree hierarchy uses terms defined in IETF RFC 8407.

### 7.4.1 Tree hierarchy

```

module: ieee802-ethernet-pon
  augment /if:interfaces/if:interface/ieee802-eth-if:ethernet:
    +---rw fec-mode?
    +---rw mpcp-admin-state?
    +---ro mpcp-logical-link-admin-state?
    +---rw trx-transmit-admin-state?
    +---ro capabilities
    | +---ro mpcp-supported? mpcp-supported
    +---ro statistics-mpcp
    | +---ro out-mpcp-mac-ctrl-frames? yang:counter64
    | +---ro in-mpcp-mac-ctrl-frames? yang:counter64
    | +---ro mpcp-discovery-window-count? yang:counter64
    | +---ro mpcp-discovery-timeout-count? yang:counter64
    | +---ro out-mpcp-register-req? yang:counter64
    | +---ro in-mpcp-register-req? yang:counter64
    | +---ro out-mpcp-register-ack? yang:counter64
    | +---ro in-mpcp-register-ack? yang:counter64
    | +---ro out-mpcp-report? yang:counter64
    | +---ro in-mpcp-report? yang:counter64
    | +---ro out-mpcp-gate? yang:counter64
    | +---ro in-mpcp-gate? yang:counter64
    | +---ro out-mpcp-register? yang:counter64
    | +---ro in-mpcp-register? yang:counter64
    +---rw statistics-ompe
    | +---ro in-ompe-frames-errored-sld? yang:counter64
    | +---ro in-ompe-frames-errored-crc8? yang:counter64
    | +---ro ompe-onu-frames-with-good-llid-good-crc8? yang:counter64

```

<sup>9</sup> Copyright release for YANG modules: Users of this standard may freely reproduce the YANG module contained in this subclause so that it can be used for its intended purpose.

```

| +---ro in-ompe-frames-with-bad-llid?          yang:counter64
| +---ro in-ompe-frames-with-good-llid?       yang:counter64
| +---ro in-ompe-frames?                       yang:counter64
| +---ro in-ompe-frames-not-match-onu-llid-broadcast? yang:counter64
| +---ro in-ompe-frames-match-onu-llid-not-broadcast? yang:counter64
| +---ro in-ompe-frames-match-onu-llid-broadcast? yang:counter64
| +---ro in-ompe-frames-not-match-onu-llid-not-broadcast? yang:counter64
+---rw thresholds-trx {trx-power-level-reporting-supported}?
| +---rw in-trx-power-low-threshold?          int32 {trx-power-level-reporting-supported}?
| +---rw in-trx-power-high-threshold?        int32 {trx-power-level-reporting-supported}?
| +---rw out-trx-power-low-threshold?        int32 {trx-power-level-reporting-supported}?
| +---rw out-trx-power-high-threshold?       int32 {trx-power-level-reporting-supported}?
+---rw statistics-trx {trx-power-level-reporting-supported}?
| +---ro in-trx-power-signal-detect?         boolean
| +---ro in-trx-power?                       int32
| +---ro in-trx-power-low-15-minutes-bin?    int32
| +---ro in-trx-power-high-15-minutes-bin?   int32
| +---ro out-trx-power-signal-detect?        boolean
| +---ro out-trx-power?                     int32
| +---ro out-trx-power-low-15-minutes-bin?   int32
| +---ro out-trx-power-high-15-minutes-bin?  int32
| +---ro trx-data-reliable?                 boolean {trx-power-level-reporting-supported}?
+---ro statistics-pon-fec {fec-supported}?
| +---ro fec-code-group-violations?         yang:counter64
| +---ro fec-buffer-head-coding-violations? yang:counter64
| +---ro fec-code-word-corrected-errors?    yang:counter64
| +---ro fec-code-word-uncorrected-errors?  yang:counter64
+---rw mpcp-logical-link-admin-actions
| +---x state-change-action-type           identityref
| | +---w input
| | +---w state-change-action-type?       identityref
| +---x reset-action-type
| | +---w input
| | +---w reset-action-type?             identityref
| +---x register-type
| | +---w input

```

```

| +---w register-type? identityref
+---rw mpcp-queues* [mpcp-queue-index] uint8
| +---rw mpcp-queue-index uint8
| +---rw mpcp-queue-threshold-count? uint8
| +---ro mpcp-queue-threshold-count-max? uint8
| +---rw mpcp-queue-thresholds* [mpcp-queue-set-index]
| | +---rw mpcp-queue-set-index uint8
| | +---rw mpcp-queue-set-threshold? uint64
| +---ro in-mpcp-queue-frames? yang:counter64
| +---ro out-mpcp-queue-frames? yang:counter64
| +---ro mpcp-queue-frames-drop? yang:counter64
+---rw multicast-IDs* [multicast-ID]
| +---rw multicast-ID uint32
+---ro fec-capability? fec-capability
+---ro mpcp-mode? mpcp-mode
+---ro mpcp-sync-time? uint64
+---ro mpcp-logical-link-id? mpcp-supported
+---ro mpcp-remote-mac-address? yang:mac-address
+---ro mpcp-logical-link-state? mpcp-logical-link-state
+---ro mpcp-elapsed-time-out? uint64
+---ro mpcp-elapsed-time-in? uint64
+---ro mpcp-round-trip-time? uint16
+---ro mpcp-maximum-grant-count? uint8
+---ro mpcp-logical-link-count? mpcp-llid-count
+---ro mpcp-maximum-queue-count-per-report? mpcp-maximum-queue-count-per-report
+---ro ompe-mode? ompe-mode

```

#### 7.4.2 YANG module

In the following YANG module definition, should any discrepancy between the text of the description for individual YANG nodes and the corresponding definition in 7.2 through 7.4 of this clause occur, the definitions and mappings in 7.4 shall take precedence.

An ASCII text version of the YANG module can be found at the following URL:<sup>10</sup> <https://github.com/YangModels/yang/tree/master/standard/ieee/published/802.3>.

```

module ieee802-ethernet-pon {
  yang-version 1.1;

  namespace "urn:ieee:std:802.3:yang:ieee802-ethernet-pon";

  prefix "ieee802-eth-pon";

  revision 2019-06-21 {
    description "Initial revision.";
  }

  import ietf-yang-types {
    prefix "yang";
    reference "IETF RFC 6991";
  }

  import ietf-interfaces {
    prefix "if";
    reference "IETF RFC 8343";
  }

  import ieee802-ethernet-interface {
    prefix "ieee802-eth-if";
  }

  organization
    "IEEE 802.3 Ethernet Working Group
    Web URL: http://www.ieee802.org/3/";

  contact
    "Web URL: http://www.ieee802.org/3/";

  description
    "This module contains a collection of YANG definitions for
    managing the Multi Point Control Protocol for Ethernet PON (EPON),
    as defined in IEEE Std 802.3, Clause 64 and Clause 77.
    This YANG module augments the 'ethernet' module.";

  reference
    "IEEE Std 802.3-2018, Clause 64 and Clause 77, unless dated explicitly
    IEEE Std 802.3.1-2013, Clause 9, unless dated explicitly";

  typedef mpcp-supported {
    type boolean;
  }

```

<sup>10</sup>Copyright release for YANG modules: Users of this standard may freely reproduce the YANG module contained in this subclause so that it can be used for its intended purpose.

IEEE Std 802.3.2-2019  
IEEE Standard for Ethernet YANG Data Model Definitions

```

description
  "This object indicates that the given interface supports MPCP,
  i.e., it is an Ethernet PON (EPON) interface.";
}

typedef mpcp-llid {
  type uint64 {
    range "0 .. 32767";
  }

  description
    "Logical Link Identifiers (LLIDs) are used to identify a single
    MAC from a number of MACs which may be present in the
    EPON OLT or ONU. LLIDs between the value of 0x07FFE
    and 0x7FFF are assigned for ONU discovery and registration.
    Other LLIDs are dynamically assigned by the OLT during the
    registration process. For a complete description of how the
    LLID is used in an EPON device, see IEEE Std 802.3, Clause 65
    for 1G-EPON and Clause 76 for 10G-EPON.";

  reference
    "IEEE Std 802.3, 65.1.3.3 for 1G-EPON and 76.2.6.1.3 for 10G-EPON";
}

typedef mpcp-maximum-queue-count-per-report {
  type uint8 {
    range "0..7";
  }

  default "0";

  description
    "Defines the maximum number of queues (0-7) in the REPORT
    MPCPDU as defined in IEEE Std 802.3, Clause 64 and Clause 77.";
}

typedef mpcp-llid-count {
  type uint64 {
    range "0 .. 32767";
  }

  description
    "Indicates the number of registered LLIDs. The initialization
    value is 0. This is applicable for an OLT with the same value
    for all logical interfaces and for an ONU.";

  reference
    "IEEE Std 802.3, 65.1.3.3 for 1G-EPON and 76.2.6.1.3 for 10G-EPON";
}

typedef mpcp-admin-state {
  type enumeration {

    enum enabled {
      description
        "When selecting the value of 'enabled', the MultiPoint
        Control Protocol sublayer on the OLT / ONU is enabled.";
    }
  }
}

```

```
enum disabled {
  description
    "When selecting the value of 'disabled', the MultiPoint
    Control Protocol sublayer on the OLT / ONU is disabled.";
}

description
  "Enumeration of valid administrative states for a MultiPoint MAC
  Control sublayer on the OLT or ONU.";

reference
  "IEEE Std 802.3, 30.3.5.2.1";
}

typedef mpcp-mode {
  type enumeration {
    enum olt {
      description
        "MPCP mode: olt";
    }

    enum onu {
      description
        "MPCP mode: onu";
    }
  }

  description
    "Enumeration of valid MPCP modes for EPON interfaces.";

  reference
    "IEEE Std 802.3, 30.3.5.1.3";
}

typedef mpcp-logical-link-state {
  type enumeration {
    enum unregistered {
      description
        "MPCP registration state: logical link is NOT registered.";
    }

    enum registering {
      description
        "MPCP registration state: logical link is currently in the
        process of registering.";
    }

    enum registered {
      description
        "MPCP registration state: logical link is currently
        registered.";
    }
  }

  description
    "Enumerations of valid MPCP registration states for EPON
    interfaces.";
```

IEEE Std 802.3.2-2019  
IEEE Standard for Ethernet YANG Data Model Definitions

```

reference
  "IEEE Std 802.3, 30.3.5.1.6";
}

typedef mpcp-logical-link-admin-state {
  type enumeration {
    enum reset {
      description
        "When read, the value of 'reset' indicates that the given
        logical link on the OLT / ONU has been reset.";
    }
    enum operate {
      description
        "When read, the value of 'operate' indicates that the
        given logical link on the OLT / ONU has moved into
        operating mode.";
    }
    enum unknown {
      description
        "When read, the value of 'unknown' indicates that the
        status of the given logical link on the OLT / ONU is
        currently not known.";
    }
    enum registered {
      description
        "When read, the value of 'registered' indicates that the
        given logical link on the OLT / ONU has been registered.";
    }
    enum deregistered {
      description
        "When read, the value of 'deregistered' indicates that the
        given logical link on the OLT / ONU has been deregistered.";
    }
    enum reregistered {
      description
        "When read, the value of 'reregistered' indicates that the
        given logical link on the OLT / ONU has been reregistered.";
    }
  }
  description
    "Enumeration of valid administrative states for a logical link
    on the OLT or ONU.";
}

typedef ompe-mode {
  type enumeration {
    enum unknown {
      description
        "omp-emulation mode: unknown = system is initializing";
    }

    enum olt {
      description
        "omp-emulation mode: olt";
    }

    enum onu {
      description

```

```
        "omp-emulation mode: onu";
    }
}

description
    "Enumeration of valid OMP-Emulation modes for EPON
    interfaces.";

reference
    "IEEE Std 802.3, 30.3.7.1.2";
}

typedef fec-capability {
    type enumeration {
        enum unknown {
            description
                "FEC capability: unknown = system is initializing.";
        }

        enum supported {
            description
                "FEC capability: supported.";
        }

        enum "not supported" {
            description
                "FEC capability: not supported.";
        }
    }
}

description
    "Enumeration of valid FEC capability values for EPON
    interfaces with enabled MPCP.";

reference
    "IEEE Std 802.3, 30.5.11.15";
}

typedef fec-mode {
    type enumeration {
        enum unknown {
            description
                "FEC mode: unknown = system is initializing.";
        }

        enum disabled {
            description
                "FEC mode: disabled = FEC is disabled for the given
                logical link (both Tx and Rx directions).";
        }

        enum enabled-Tx-Rx {
            description
                "FEC mode: enabled-Tx-Rx = FEC is enabled for the given
                logical link in both Tx and Rx directions.";
        }

        enum enabled-Tx-only {
            description

```

IEEE Std 802.3.2-2019  
IEEE Standard for Ethernet YANG Data Model Definitions

```

    "FEC mode: enabled-Tx-only = FEC is enabled for
    the given logical link but only in Tx direction.";
  }

  enum enabled-Rx-only {
    description
      "FEC mode: enabled-Rx-only = FEC is enabled for
      the given logical link but only in Rx direction.";
  }
}

description
  "Enumeration of valid FEC modes for EPON interfaces.";

reference
  "IEEE Std 802.3, 30.5.1.1.16";
}

typedef trx-admin-state {
  type enumeration {
    enum enabled {
      description
        "When read as 'enabled', the transmitter is enabled and
        operating under the control of the logical control protocol.
        When set to 'enabled', the transmitter is enabled to
        operate under the control of the logical control protocol.";
    }

    enum disabled {
      description
        "When read as 'disabled', the transmitter is currently
        disabled (not transmitting). When set to 'disabled', the
        transmitter is expected to be disabled (to stop transmitting).";
    }
  }

  description
    "Enumeration of valid administrative states for an optical
    transceiver.";

  reference
    "IEEE Std 802.3.1, dot3ExtPkgOptIfTransmitEnable";
}

feature trx-power-level-reporting-supported {
  description
    "This object indicates the support for optical transceiver power
    level monitoring and reporting capability. When 'true', the
    given interface supports the optical power level monitoring
    and reporting function. Otherwise, the value is 'false'.";
}

feature
fec-supported {
  description
    "This object indicates the support of operation of the optional
    FEC sublayer of the 1G-EPON PHY specified in IEEE Std 802.3,
    65.2. The value of 'unknown' is reported in the initialization,

```

for non FEC support state or type not yet known. The value of 'not supported' is reported when the sublayer is not supported. The value of 'supported' is reported when the sublayer is supported. This object is applicable for an OLT, with the same value for all logical links, and for an ONU.";

```

reference
  "IEEE Std 802.3, 30.5.1.1.15";
}

identity state-change-action-type {
  description
    "Type of interface state change requested.";
}

identity power-down {
  base state-change-action-type;
  description
    "Power down the EPON logical interface.
    Power-down actions are applicable for the OLT and ONU. A
    power down of a specific logical interface affects only
    the logical interface (and not the physical interface).
    the logical interface will be unavailable while the
    power-down occurs and data may be lost. Other logical
    interface are unaffected by power-down.

    This action is relevant when the admin state is active.";
}

identity power-up {
  base state-change-action-type;
  description
    "Exit EPON logical interface power-down state.";
}

identity reset-action-type {
  description
    "Type of reset action requested.";
}

identity reset-interface {
  base reset-action-type;
  description
    "Reset the EPON logical interface. Resetting an interface
    can lead an interruption of service for the users connected
    to the respective EPON interface.

    This object is applicable for an OLT and an ONU. At the
    OLT, it has a distinct value for each logical interface.
    A reset for a specific logical interface resets only
    this logical interface and not the physical interface.

    Thus, a logical link that is malfunctioning can be
    reset without affecting the operation of other logical
    interfaces.

    The reset can cause Discontinuities in the values of the
    counters of the interface, similar to re-initialization
    of the management system.";
}

identity register-type {

```

IEEE Std 802.3.2-2019  
IEEE Standard for Ethernet YANG Data Model Definitions

```

description
  "Type of registration requested.";
}
identity register {
  base register-type;
  description
    "Register indicates a request to register an LLID.
    This action applies to an OLT or ONU logical interface.";
}
identity reregister {
  base register-type;
  description
    "Re-register indicates an request to re-register an LLID.
    This action applies to an OLT or ONU logical interface.";
}
identity deregister {
  base register-type;
  description
    "De-register indicates an request to de-register an LLID.
    This action applies to an OLT or ONU logical interface.
    Deregister may result in an interruption of service to
    users connected to the respective EPON interface.";
}

augment "/if:interfaces/if:interface/ieee802-eth-if:ethernet" {
  description
    "Augments the definition of Ethernet interface (/if:interfaces/
    if:interface/ieee802-eth-if:ethernet) module with nodes
    specific to Ethernet PON (EPON).";

  leaf fec-mode {
    if-feature "fec-supported";

    type fec-mode;

    description
      "This object reflects the current administrative state of the
      FEC function for the given logical link on an ONU or OLT.

      When reading the value of 'disabled', the FEC function on the
      given logical link is disabled.

      When reading the value of 'enabled-Tx-Rx', the FEC function on
      the given logical link is enabled in both Tx and Rx directions.

      When reading the value of 'enabled-Tx-only', the FEC function
      on the given logical link is enabled in Tx direction only.

      When reading the value of 'enabled-Rx-only', the FEC function
      on the given logical link is enabled in Rx direction only.

      When reading the value of 'unknown', the state of the FEC
      function on the given logical link is unknown or the FEC
      function is currently initializing.

      This object is applicable for an OLT and an ONU. This object has
      the same value for each logical link.";
  }
}

```

```
reference
  "IEEE Std 802.3, 30.5.1.1.16";
}

leaf mpcp-admin-state {
  type mpcp-admin-state;

  description
    "This object reflects the current administrative state of the
    MultiPoint MAC Control sublayer, as defined in IEEE Std 802.3,
    Clause 64 and Clause 77, for the OLT / ONU.

    When reading the value of 'enabled', the MultiPoint Control
    Protocol on the OLT / ONU is enabled.

    When reading the value of 'disabled', the MultiPoint Control
    Protocol on the OLT / ONU is disabled.

    This object is applicable for an OLT and an ONU. It has the
    same value for all logical links.";

  reference
    "IEEE Std 802.3, 30.3.5.1.2";
}

leaf mpcp-logical-link-admin-state {
  type mpcp-logical-link-admin-state;
  config false;
  description
    "This object reflects the current administrative state of a
    logical link on an ONU or OLT.

    When reading the value of 'reset', the given logical link is
    undergoing a reset.

    When reading the value of 'unknown', the current status of the
    given logical link is unknown and the link might be undergoing
    initialization.

    When reading the value of 'operate', the given logical link is
    operating normally.

    When reading the value of 'registered', the given logical link
    was requested to perform registration.

    When reading the value of 'deregistered', the given logical
    link was requested to perform deregistration.

    When reading the value of 'reregistered', the given logical
    link was requested to perform reregistration.

    This object is applicable for an OLT and an ONU. It has a
    distinct value for each logical link.";

  reference
    "IEEE Std 802.3.1, dot3ExtPkgObjectRegisterAction";
}

leaf trx-transmit-admin-state {
```

IEEE Std 802.3.2-2019  
IEEE Standard for Ethernet YANG Data Model Definitions

```

when
  "../../ieee802-eth-if:ethernet/
    ieee802-eth-pon:mpcp-admin-state = 'enabled'";

if-feature "trx-power-level-reporting-supported";

type trx-admin-state;

description
  "This object reflects the current status of the transmitter in
  the optical transceiver.

  When read as 'enabled', the optical transmitter is enabled and
  operating under the control of the logical control protocol.

  When read as 'disabled', the optical transmitter is disabled.

  This object is applicable for an OLT and an ONU. At the OLT, this
  object has a distinct value for each logical link.

  The value of this object is only reliable when
  /if:interfaces-state/if:interface/ieee802-eth-if:ethernet/
  'mpcp-admin-state' is equal to 'enabled'.";

reference
  "IEEE Std 802.3.1, dot3ExtPkgOptIfTransmitEnable";
}

container capabilities {

  config false;
  description
    "This container includes all EPON interface-specific capabilities.";

  leaf mpcp-supported {
    type mpcp-supported;

    default
      "true";
    description
      "This object indicates that the given interface supports MPCP,
      i.e., it is an Ethernet PON (EPON) interface.";
  }
}

container statistics-mpcp {
  config false;
  description
    "This container defines a set of MPCP-related statistics
    counters of an EPON interface, as defined in
    IEEE Std 802.3, Clause 64 and Clause 77.";

  leaf out-mpcp-mac-ctrl-frames {
    type yang:counter64;

    units frames;

    config false;

```

```

description
  "A count of MPCP frames passed to the MAC sublayer for
  transmission.

  This counter is incremented when a MA_CONTROL.request
  service primitive is generated within the MAC control
  sublayer with an opcode indicating an MPCP frame.

  This object is applicable for an OLT and an ONU. It has a
  distinct value for each logical link.

  Discontinuities of this counter can occur at
  re-initialization of the management system, and at other
  times, as indicated by the value of the 'discontinuity-time'
  leaf defined in the ietf-interfaces YANG module (IETF RFC 8343).";

reference
  "IEEE Std 802.3, 30.3.5.1.7";
}

leaf in-mpcp-mac-ctrl-frames {
  type yang:counter64;

  units frames;

  config false;

  description
    "A count of MPCP frames passed by the MAC sublayer to the
    MAC Control sublayer.

    This counter is incremented when a frame is received at the
    interface which is an MPCP frame or has a Length/Type Ethernet
    header field value equal to the Type assigned for
    802.3_MAC_Control as specified in IEEE Std 802.3, 31.4.1.3.

    This object is applicable for an OLT and an ONU. It has a
    distinct value for each logical link.

    Discontinuities in the value of this counter can occur at
    re-initialization of the management system, and at other times
    as indicated by the value of the 'discontinuity-time' leaf
    defined in the ietf-interfaces YANG module (IETF RFC 8343).";

  reference
    "IEEE Std 802.3, 30.3.5.1.8";
}

leaf mpcp-discovery-window-count {
  when "../ompe-mode = 'olt'";
  type yang:counter64;

  units "discovery windows";

  config false;

  description
    "A count of discovery windows generated by the OLT.

```

IEEE Std 802.3.2-2019  
IEEE Standard for Ethernet YANG Data Model Definitions

The counter is incremented by one for each generated discovery window.

This object is applicable for an OLT and has the same value for each logical link.

Discontinuities in the value of this counter can occur at re-initialization of the management system, and at other times as indicated by the value of the 'discontinuity-time' leaf defined in the ietf-interfaces YANG module (IETF RFC 8343).";

```
reference
  "IEEE Std 802.3, 30.3.5.1.22";
}
```

```
leaf mpcp-discovery-timeout-count {
  when "../ompe-mode = 'olt'";
  type yang:counter64;
```

```
  units "discovery timeouts";
```

```
  config false;
```

```
  description
```

```
    "A count of the number of times a discovery timeout occurs.
```

This counter is incremented by one for each discovery processing state-machine reset resulting from timeout waiting for message arrival.

This object is applicable for an OLT and has the same value for each logical link.

Discontinuities in the value of this counter can occur at re-initialization of the management system, and at other times as indicated by the value of the 'discontinuity-time' leaf defined in the ietf-interfaces YANG module (IETF RFC 8343).";

```
reference
  "IEEE Std 802.3, 30.3.5.1.23";
}
```

```
leaf out-mpcp-register-req {
  when "../ompe-mode = 'onu'";
  type yang:counter64;
```

```
  units frames;
```

```
  config false;
```

```
  description
```

```
    "A count of the number of times a REGISTER_REQ MPCP frame transmission occurs.
```

This counter is incremented by one for each REGISTER\_REQ MPCP frame transmitted as defined in IEEE Std 802.3, Clause 64 and Clause 77.

This object is applicable for an ONU and has the same value

for each logical link.

Discontinuities in the value of this counter can occur at re-initialization of the management system, and at other times as indicated by the value of the 'discontinuity-time' leaf defined in the ietf-interfaces YANG module (IETF RFC 8343).";

```
reference
  "IEEE Std 802.3, 30.3.5.1.12";
}
```

```
leaf in-mpcp-register-req {
  when "../ompe-mode = 'olt'";
  type yang:counter64;
```

```
  units frames;
```

```
  config false;
```

```
  description
```

"A count of the number of times a REGISTER\_REQ MPCP frame reception occurs.

This counter is incremented by one for each REGISTER\_REQ MPCP frame received as defined in IEEE Std 802.3, Clause 64 and Clause 77.

This object is applicable for an OLT and has the same value for each logical link.

Discontinuities in the value of this counter can occur at re-initialization of the management system, and at other times as indicated by the value of the 'discontinuity-time' leaf defined in the ietf-interfaces YANG module (IETF RFC 8343).";

```
reference
  "IEEE Std 802.3, 30.3.5.1.17";
}
```

```
leaf out-mpcp-register-ack {
  when "../ompe-mode = 'onu'";
  type yang:counter64;
```

```
  units frames;
```

```
  config false;
```

```
  description
```

"A count of the number of times a REGISTER\_ACK MPCP frame transmission occurs.

This counter is incremented by one for each REGISTER\_ACK MPCP frame transmitted as defined in IEEE Std 802.3, Clause 64 and Clause 77.

This object is applicable for an ONU and has a distinct value for each logical link.

Discontinuities in the value of this counter can occur at

IEEE Std 802.3.2-2019  
IEEE Standard for Ethernet YANG Data Model Definitions

re-initialization of the management system, and at other times as indicated by the value of the 'discontinuity-time' leaf defined in the ietf-interfaces YANG module (IETF RFC 8343).";

```

reference
  "IEEE Std 802.3, 30.3.5.1.10";
}

leaf in-mpcp-register-ack {
  when "../ompe-mode = 'olt'";
  type yang:counter64;

  units frames;

  config false;

  description
    "A count of the number of times a REGISTER_ACK MPCP frame
    reception occurs.

    This counter is incremented by one for each REGISTER_ACK MPCP
    frame received as defined in IEEE Std 802.3,
    Clause 64 and Clause 77.

    This object is applicable for an OLT and has a distinct
    value for each logical link.

    Discontinuities of this counter can occur at
    re-initialization of the management system and at other
    times, as indicated by the value of the 'discontinuity-time'
    leaf defined in the ietf-interfaces YANG module (IETF RFC 8343).";

  reference
    "IEEE Std 802.3, 30.3.5.1.15";
}

leaf out-mpcp-report {
  when "../ompe-mode = 'onu'";
  type yang:counter64;

  units frames;

  config false;

  description
    "A count of the number of times a REPORT MPCP frame
    transmission occurs.

    This counter is incremented by one for each REPORT MPCP frame
    transmitted as defined in IEEE Std 802.3,
    Clause 64 and Clause 77.

    This object is applicable for an ONU and has a distinct value for
    each logical link.

    Discontinuities of this counter can occur at
    re-initialization of the management system and at other
    times, as indicated by the value of the 'discontinuity-time'
    leaf defined in the ietf-interfaces YANG module (IETF RFC 8343).";

```

```
reference
  "IEEE Std 802.3, 30.3.5.1.13";
}

leaf in-mpcp-report {
  when "../..ompe-mode = 'olt'";
  type yang:counter64;

  units frames;

  config false;

  description
    "A count of the number of times a REPORT MPCP frame
    reception occurs.

    This counter is incremented by one for each REPORT MPCP frame
    received as defined in IEEE Std 802.3,
    Clause 64 and Clause 77.

    This object is applicable for an OLT and has a distinct
    value for each logical link.

    Discontinuities in the value of this counter can occur at
    re-initialization of the management system, and at other times
    as indicated by the value of the 'discontinuity-time' leaf
    defined in the ietf-interfaces YANG module (IETF RFC 8343).";

  reference
    "IEEE Std 802.3, 30.3.5.1.18";
}

leaf out-mpcp-gate {
  when "../..ompe-mode = 'olt'";
  type yang:counter64;

  units frames;

  config false;

  description
    "A count of the number of times a GATE MPCP frame
    transmission occurs.

    This counter is incremented by one for each GATE MPCP frame
    transmitted as defined in IEEE Std 802.3,
    Clause 64 and Clause 77.

    This object is applicable for an OLT and has a distinct
    value for each logical link.

    Discontinuities of this counter can occur at
    re-initialization of the management system and at other
    times, as indicated by the value of the 'discontinuity-time'
    leaf defined in the ietf-interfaces YANG module (IETF RFC 8343).";

  reference
    "IEEE Std 802.3, 30.3.5.1.9";
```

IEEE Std 802.3.2-2019  
IEEE Standard for Ethernet YANG Data Model Definitions

```

}

leaf in-mpcp-gate {
  when "../..ompe-mode = 'onu'";
  type yang:counter64;

  units frames;

  config false;

  description
    "A count of the number of times a GATE MPCP frame reception
    occurs.

    This counter is incremented by one for each GATE MPCP frame
    received as defined in IEEE Std 802.3,
    Clause 64 and Clause 77.

    This object is applicable for an ONU and has a distinct value
    for each logical link.

    Discontinuities of this counter can occur at
    re-initialization of the management system and at other
    times, as indicated by the value of the 'discontinuity-time'
    leaf defined in the ietf-interfaces YANG module (IETF RFC 8343).";

  reference
    "IEEE Std 802.3, 30.3.5.1.14";
}

leaf out-mpcp-register {
  when "../..ompe-mode = 'olt'";
  type yang:counter64;

  units frames;

  config false;

  description
    "A count of the number of times a REGISTER MPCP frame
    transmission occurs.

    This counter is incremented by one for each REGISTER MPCP
    frame transmitted as defined in IEEE Std 802.3,
    Clause 64 and Clause 77.

    This object is applicable for an OLT and has a distinct
    value for each logical link.

    Discontinuities of this counter can occur at
    re-initialization of the management system and at other
    times, as indicated by the value of the 'discontinuity-time'
    leaf defined in the ietf-interfaces YANG module (IETF RFC 8343).";

  reference
    "IEEE Std 802.3, 30.3.5.1.11";
}

leaf in-mpcp-register {

```

```

when "../..//ompe-mode = 'onu'";
type yang:counter64;

units frames;

config false;

description
  "A count of the number of times a REGISTER MPCP frame
  reception occurs.

  This counter is incremented by one for each REGISTER MPCP
  frame received as defined in IEEE Std 802.3,
  Clause 64 and Clause 77.

  This object is applicable for an ONU and has a distinct value
  for each logical link.

  Discontinuities of this counter can occur at
  re-initialization of the management system and at other
  times, as indicated by the value of the 'discontinuity-time'
  leaf defined in the ietf-interfaces YANG module (IETF RFC 8343).";

reference
  "IEEE Std 802.3, 30.3.5.1.16";
}
}

container statistics-ompe {
  description
    "This container defines a set of OMP-Emulation-related
    statistics counters of an EPON interface, as defined in
    IEEE Std 802.3, Clause 65 and Clause 76.";

  reference
    "IEEE Std 802.3.1, dot3OmpEmulationStatEntry";

  leaf in-ompe-frames-errored-sld {
    type yang:counter64;

    units frames;

    config false;

    description
      "A count of frames received that do not contain a valid SLD
      field as defined in IEEE Std 802.3, 65.1.3.3.1 or
      76.2.6.1.3.1, as appropriate.

      This object is applicable for an OLT and an ONU. It has a
      distinct value for each logical link.

      Discontinuities in the value of this counter can occur at
      re-initialization of the management system, and at other times
      as indicated by the value of the 'discontinuity-time' leaf
      defined in the ietf-interfaces YANG module (IETF RFC 8343).";

    reference
      "IEEE Std 802.3, 30.3.7.1.3";
  }
}

```

IEEE Std 802.3.2-2019  
IEEE Standard for Ethernet YANG Data Model Definitions

```

}

leaf in-ompe-frames-errored-crc8 {
  type yang:counter64;

  units frames;

  config false;

  description
    "A count of frames received that contain a valid SLD field,
    as defined in IEEE Std 802.3, 65.1.3.3.1 or 76.2.6.1.3.1 as
    appropriate, but do not pass the CRC-8 check as defined in
    IEEE Std 802.3, 65.1.3.3.3 or 76.2.6.1.3.3 as appropriate.

    This object is applicable for an OLT and an ONU. It has a
    distinct value for each logical link.

    Discontinuities of this counter can occur at
    re-initialization of the management system and at other
    times, as indicated by the value of the 'discontinuity-time'
    leaf defined in the ietf-interfaces YANG module (IETF RFC 8343).";

  reference
    "IEEE Std 802.3, 30.3.7.1.4";
}

leaf ompe-onu-frames-with-good-llid-good-crc8 {
  when "../ompe-mode = 'onu'";
  type yang:counter64;
  units frames;
  config false;
  description
    "A count of frames received that 1) contain a valid SLD field
    in an ONU, 2) meet the rule for frame acceptance, and
    3) pass the CRC-8 check.

    The SLD is defined in IEEE Std 802.3, 65.1.3.3.1 or
    76.2.6.1.3.1, as appropriate.

    The rules for LLID acceptance are defined in IEEE Std 802.3,
    65.1.3.3.2 or 76.2.6.1.3.2, as appropriate.

    The CRC-8 check is defined in IEEE Std 802.3,
    65.1.3.3.3 or 76.2.6.1.3.3, as appropriate.

    This object is applicable for an ONU and has a distinct value
    for each logical link.

    Discontinuities in the value of this counter can occur at
    re-initialization of the management system, and at other
    times as indicated by the value of the
    'discontinuity-time' leaf defined in the ietf-interfaces
    YANG module (IETF RFC 8343).";
  reference
    "IEEE Std 802.3, 30.3.7.1.6";
}

leaf ompe-olt-frames-with-good-llid-good-crc8 {

```

```

when "../../../ompe-mode = 'olt'";
type yang:counter64;
units frames;
config false;
description
  "A count of frames received that 1) contain a valid SLD field
  in an OLT, and 2) pass the CRC-8 check.

  The SLD is defined in IEEE Std 802.3, 65.1.3.3.1 or
  76.2.6.1.3.1, as appropriate.

  The frame acceptance are defined in IEEE Std 802.3,
  65.1.3.3.2 or 76.2.6.1.3.2, as appropriate.

  The CRC-8 check is defined in IEEE Std 802.3,
  65.1.3.3.3 or 76.2.6.1.3.3, as appropriate.

  This object is applicable for an OLT and has a distinct
  value for each logical link.

  Discontinuities in the value of this counter can occur at
  re-initialization of the management system, and at other
  times as indicated by the value of the
  'discontinuity-time' leaf defined in the ietf-interfaces
  YANG module (IETF RFC 8343).";

reference
  "IEEE Std 802.3, 30.3.7.1.6";
}

leaf in-ompe-frames-with-bad-llid {
  when "../../../ompe-mode = 'olt'";
  type yang:counter64;

  units frames;

  config false;

  description
    "A count of frames received that contain a valid SLD field, as
    defined in IEEE Std 802.3, 65.1.3.3.1 or 76.2.6.1.3.1, as
    appropriate, and pass the CRC-8 check as defined in IEEE Std
    802.3, 65.1.3.3.3 or 76.2.6.1.3.3, as appropriate, but are
    discarded due to the LLID check.

    This object is applicable for an OLT and has a distinct value
    for each logical link.

    Discontinuities in the value of this counter can occur at
    re-initialization of the management system, and at other times
    as indicated by the value of the 'discontinuity-time' leaf
    defined in the ietf-interfaces YANG module (IETF RFC 8343).";

  reference
    "IEEE Std 802.3, 30.3.7.1.8";
}

leaf in-ompe-frames-with-good-llid {
  type yang:counter64;

```

IEEE Std 802.3.2-2019  
IEEE Standard for Ethernet YANG Data Model Definitions

```

units frames;

config false;

description
  "A count of frames received that contain a valid SLD field,
  as defined in IEEE Std 802.3, 65.1.3.3.1 or 76.2.6.1.3.1 as
  appropriate, but do not pass the CRC-8 check as defined in
  IEEE Std 802.3, 65.1.3.3.3 or 76.2.6.1.3.3 as appropriate.

  This object is applicable for an OLT and an ONU. It has a
  distinct value for each logical link.

  Discontinuities in the value of this counter can occur at
  re-initialization of the management system, and at other times
  as indicated by the value of the 'discontinuity-time' leaf
  defined in the ietf-interfaces YANG module (IETF RFC 8343).";

reference
  "IEEE Std 802.3, 30.3.7.1.4";
}

leaf in-ompe-frames {
  type yang:counter64;

  units frames;

  config false;

  description
    "A count of frames received that contain a valid SLD field,
    as defined in IEEE Std 802.3, 65.1.3.3.1 or 76.2.6.1.3.1, as
    appropriate, and pass the CRC-8 check as defined in
    IEEE Std 802.3, 65.1.3.3.3 or 76.2.6.1.3.3, as appropriate.

    This object is applicable for an OLT and an ONU. It has a
    distinct value for each logical link.

    Discontinuities in the value of this counter can occur at
    re-initialization of the management system, and at other times
    as indicated by the value of the 'discontinuity-time' leaf
    defined in the ietf-interfaces YANG module (IETF RFC 8343).";

  reference
    "IEEE Std 802.3, 30.3.7.1.6 (ONU) and 30.3.7.1.7 (OLT)";
}

leaf in-ompe-frames-not-match-onu-llid-broadcast {
  when "../ompe-mode = 'onu'";

  type yang:counter64;

  units frames;

  config false;

  description
    "A count of frames received that contain a valid SLD field,

```

IEEE Std 802.3.2-2019  
IEEE Standard for Ethernet YANG Data Model Definitions

as defined in IEEE Std 802.3, 65.1.3.3.1 or 76.2.6.1.3.1, as appropriate, pass the CRC-8 check, as defined in IEEE Std 802.3, 65.1.3.3.3 or 76.2.6.1.3.3, as appropriate, and contain the broadcast bit in the LLID and not the ONU's LLID (frame accepted) as defined in IEEE Std 802.3, Clause 65 and Clause 76, as appropriate.

This object is applicable for an ONU only.

Discontinuities in the value of this counter can occur at re-initialization of the management system, and at other times as indicated by the value of the 'discontinuity-time' leaf defined in the ietf-interfaces YANG module (IETF RFC 8343).";

```

reference
  "IEEE Std 802.3.1, dot3OmpEmulationBroadcastBitNotOnuLlid"
}

leaf in-ompe-frames-match-onu-llid-not-broadcast {
  when "../ompe-mode = 'onu'";

  type yang:counter64;

  units frames;

  config false;

  description
    "A count of frames received that contain a valid SLD field,
    as defined in IEEE Std 802.3, 65.1.3.3.1 or 76.2.6.1.3.1, as
    appropriate, pass the CRC-8 check, as defined in
    IEEE Std 802.3, 65.1.3.3.3 or 76.2.6.1.3.3, as appropriate,
    and contain the ONU's LLID (frame accepted) as defined in
    IEEE Std 802.3, Clause 65 and Clause 76, as appropriate.

    This object is applicable for an ONU only.

    Discontinuities in the value of this counter can occur at
    re-initialization of the management system, and at other times
    as indicated by the value of the 'discontinuity-time' leaf
    defined in the ietf-interfaces YANG module (IETF RFC 8343).";

  reference
    "IEEE Std 802.3.1, dot3OmpEmulationOnuLLIDNotBroadcast";
}

leaf in-ompe-frames-match-onu-llid-broadcast {
  when "../ompe-mode = 'onu'";

  type yang:counter64;

  units frames;

  config false;

  description
    "A count of frames received that contain a valid SLD field,
    as defined in IEEE Std 802.3, 65.1.3.3.1 or 76.2.6.1.3.1, as
    appropriate, pass the CRC-8 check, as defined in

```

IEEE Std 802.3.2-2019  
IEEE Standard for Ethernet YANG Data Model Definitions

IEEE Std 802.3, 65.1.3.3.3 or 76.2.6.1.3.3, as appropriate, and contain the broadcast bit in the LLID and the ONU's LLID (frame accepted) as defined in IEEE Std 802.3, Clause 65 and Clause 76, as appropriate.

This object is applicable for an ONU only.

Discontinuities in the value of this counter can occur at re-initialization of the management system, and at other times as indicated by the value of the 'discontinuity-time' leaf defined in the ietf-interfaces YANG module (IETF RFC 8343).";

reference

"IEEE Std 802.3.1, dot3OmpEmulationBroadcastBitPlusOnuLlid";

}

leaf in-ompe-frames-not-match-onu-llid-not-broadcast {  
when "../ompe-mode = 'onu'";

type yang:counter64;

units frames;

config false;

description

"A count of frames received that contain a valid SLD field, as defined in IEEE Std 802.3, 65.1.3.3.1 or 76.2.6.1.3.1, as appropriate, pass the CRC-8 check, as defined in IEEE Std 802.3, 65.1.3.3.3 or 76.2.6.1.3.3, as appropriate, do not contain the broadcast bit in the LLID and do not contain the ONU's LLID (frame is NOT accepted) as defined in IEEE Std 802.3, Clause 65 and Clause 76, as appropriate.

This object is applicable for an ONU only.

Discontinuities in the value of this counter can occur at re-initialization of the management system, and at other times as indicated by the value of the 'discontinuity-time' leaf defined in the ietf-interfaces YANG module (IETF RFC 8343).";

reference

"IEEE Std 802.3.1, dot3OmpEmulationNotBroadcastBitNotOnuLlid";

}

container thresholds-trx {

if-feature "trx-power-level-reporting-supported";

description

"This container defines a set of optical transceiver thresholds of an EPON interface as defined in IEEE Std 802.3, Clause 60 and Clause 75.";

reference

"IEEE Std 802.3.1, dot3ExtPkgOptIfEntry";

leaf in-trx-power-low-threshold {

if-feature "trx-power-level-reporting-supported";

```

type int32;

units "0.1 dBm";

description
  "This object reflects the current setting of low alarm
  threshold for the input power into the optical receiver.
  If the value reported in 'in-trx-power' object drops below
  the value set in 'in-trx-power-low-threshold', a
  'in-trx-power-low-threshold-crossing' event is generated.

  This object is applicable for an OLT and an ONU. It has a
  distinct value for each logical link.";

reference
  "IEEE Std 802.3.1, dot3ExtPkgOptIfLowerInputPowerThreshold";
}

leaf in-trx-power-high-threshold {
  if-feature "trx-power-level-reporting-supported";

  type int32;

  units "0.1 dBm";

  description
    "This object reflects the current setting of high alarm
    threshold for the input power into the optical receiver. If
    the value reported in 'in-trx-power' object exceeds the
    value set in 'in-trx-power-high-threshold', a
    'in-trx-power-high-threshold-crossing' event is generated.

    This object is applicable for an OLT and an ONU. It has a
    distinct value for each logical link.";

  reference
    "IEEE Std 802.3.1, dot3ExtPkgOptIfUpperInputPowerThreshold";
}

leaf out-trx-power-low-threshold {
  if-feature "trx-power-level-reporting-supported";

  type int32;

  units "0.1 dBm";

  description
    "This object reflects the current setting of low alarm
    threshold for the output power out of the optical
    transmitter. If the value reported in 'out-trx-power' object
    drops below the value set in 'out-trx-power-low-threshold',
    a 'out-trx-power-low-threshold-crossing' event is generated.

    This object is applicable for an OLT and an ONU. It has a
    distinct value for each logical link.";

  reference
    "IEEE Std 802.3.1, dot3ExtPkgOptIfLowerOutputPowerThreshold";
}

```

IEEE Std 802.3.2-2019  
IEEE Standard for Ethernet YANG Data Model Definitions

```

leaf out-trx-power-high-threshold {
  if-feature "trx-power-level-reporting-supported";

  type int32;

  units "0.1 dBm";

  description
    "This object reflects the current setting of high alarm
    threshold for the output power out of the optical
    transmitter. If the value reported in 'out-trx-power' object
    exceeds the value set in 'out-trx-power-high-threshold', a
    'out-trx-power-high-threshold-crossing' event is generated.

    This object is applicable for an OLT and an ONU. It has a
    distinct value for each logical link.";

  reference
    "IEEE Std 802.3.1, dot3ExtPkgOptIfUpperOutputPowerThreshold";
}
}
container statistics-trx {
  if-feature "trx-power-level-reporting-supported";

  description
    "This container defines a set of optical transceiver
    statistics counters of an EPON interface as defined in
    IEEE Std 802.3, Clause 60 and Clause 75.";

  reference
    "IEEE Std 802.3.1, dot3ExtPkgOptIfEntry";

  leaf in-trx-power-signal-detect {
    type boolean;

    config false;

    description
      "This object indicates whether a valid optical signal was
      detected (when read as 'true') or not (when read as 'false')
      at the input to the optical transceiver.

      This object is applicable for an OLT and an ONU. It has a
      distinct value for each logical link.";

    reference
      "IEEE Std 802.3.1, dot3ExtPkgOptIfSignalDetect";
  }
}
leaf in-trx-power {
  type int32;

  units "0.1 dBm";

  config false;

  description
    "This object reflects the value of the input power, as

```

measured at the optical transceiver, expressed in units of 0.1 dBm.

At the ONU, the measurement is performed in a continuous manner.

At the OLT, the measurement is performed in a burst-mode manner, for each incoming data burst.

This object is applicable for an OLT and an ONU. It has a distinct value for each logical link.";

```
reference
  "IEEE Std 802.3.1, dot3ExtPkgOptIfInputPower";
}

leaf in-trx-power-low-15-minutes-bin {
  type int32;

  units "0.1 dBm";

  config false;

  description
    "This object reflects the lowest value of the input power
    during the period of the last 15 minutes, as measured at the
    optical transceiver, and expressed in units of 0.1 dBm.

    At the ONU, the measurement is performed in a continuous
    manner and stored in a rolling 15-minutes' long observation
    bin.

    At the OLT, the measurement is the average power for each
    incoming data burst, and stored in a rolling 15-minutes'
    long observation bin.

    This object is applicable for an OLT and an ONU. It has a
    distinct value for each logical link.";

  reference
    "IEEE Std 802.3.1, dot3ExtPkgOptIfLowInputPower";
}

leaf in-trx-power-high-15-minutes-bin {
  type int32;

  units "0.1 dBm";

  config false;

  description
    "This object reflects the highest value of the input power
    during the period of the last 15 minutes, as measured at the
    optical transceiver, and expressed in units of 0.1 dBm.

    At the ONU, the measurement is performed in a continuous
    manner and stored in a rolling 15-minutes' long observation
    bin.
```

IEEE Std 802.3.2-2019  
IEEE Standard for Ethernet YANG Data Model Definitions

At the OLT, the measurement is the average power for each incoming data burst, and stored in a rolling 15-minutes' long observation bin.

This object is applicable for an OLT and an ONU. It has a distinct value for each logical link.";

```

reference
  "IEEE Std 802.3.1, dot3ExtPkgOptIfHighInputPower";
}

leaf out-trx-power-signal-detect {
  type boolean;

  config false;

  description
    "This object indicates whether a valid optical signal was
    detected (when read as 'true') or not (when read as 'false')
    at the output from the optical transceiver.

    This object is applicable for an OLT and an ONU. It has a
    distinct value for each logical link.";

  reference
    "IEEE Std 802.3.1, dot3ExtPkgOptIfTransmitAlarm";
}

leaf out-trx-power {
  type int32;

  units "0.1 dBm";

  config false;

  description
    "This object reflects the value of the output power, as
    measured at the optical transceiver, expressed in units of
    0.1 dBm.

    At the ONU, the measurement is performed in a burst-mode
    manner for each outgoing data burst.

    At the OLT, the measurement is performed in a continuous
    manner.

    This object is applicable for an OLT and an ONU. It has a
    distinct value for each logical link.";

  reference
    "IEEE Std 802.3.1, dot3ExtPkgOptIfOutputPower";
}

leaf out-trx-power-low-15-minutes-bin {
  type int32;

  units "0.1 dBm";

  config false;

```

## description

"This object reflects the lowest value of the output power during the period of the last 15 minutes, as measured at the optical transceiver, and expressed in units of 0.1 dBm.

At the ONU, the measurement is performed in a burst-mode manner and stored in a rolling 15-minutes' long observation bin.

At the OLT, the measurement is the average power for each incoming data burst, and stored in a rolling 15-minutes' long observation bin.

This object is applicable for an OLT and an ONU. It has a distinct value for each logical link.";

## reference

"IEEE Std 802.3.1, dot3ExtPkgOptIfLowOutputPower";

}

leaf out-trx-power-high-15-minutes-bin {  
  type int32;

  units "0.1 dBm";

  config false;

## description

"This object reflects the highest value of the output power during the period of the last 15 minutes, as measured at the optical transceiver, and expressed in units of 0.1 dBm.

At the ONU, the measurement is performed in a burst-mode manner and stored in a rolling 15-minutes' long observation bin.

At the OLT, the measurement is the average power for each incoming data burst, and stored in a rolling 15-minutes' long observation bin.

This object is applicable for an OLT and an ONU. It has a distinct value for each logical link.";

## reference

"IEEE Std 802.3.1, dot3ExtPkgOptIfHighOutputPower";

}

leaf trx-data-reliable {  
  if-feature "trx-power-level-reporting-supported";

  type boolean;

  config false;

## description

"This object indicates whether data contained in individual counters in 'statistics-trx' container are reliable (when read as 'true') or not (when read as 'false').

IEEE Std 802.3.2-2019  
IEEE Standard for Ethernet YANG Data Model Definitions

This object is applicable for an OLT and an ONU. It has a distinct value for each logical link.";

```

reference
  "IEEE Std 802.3.1, dot3ExtPkgOptIfSuspectedFlag";
}
}

container statistics-pon-fec {
  when
    "(../fec-capability = 'supported') and
    (../fec-mode = 'enabled-Tx-Rx')";

  if-feature "fec-supported";

  config false;

  description
    "This container defines a set of FEC-related statistics
    counters of an EPON interface, as defined in
    IEEE Std 802.3, Clause 65 and Clause 76.";

  reference
    "IEEE Std 802.3.1, dot3OmpEmulationStatEntry";

  leaf fec-code-group-violations {
    type yang:counter64;

    units code-group;

    config false;

    description
      "For 1G-EPON this is a count of the number of events that
      cause the PHY to indicate 'Data reception error' or
      'Carrier Extend Error' on the GMII (see IEEE Std 802.3,
      Table 35-1). The contents of this counter is undefined when
      FEC is operating. For 10G-EPON this object is not applicable.

      This object is applicable for an OLT and an ONU. At the
      OLT, it has a distinct value for each logical link.

      Discontinuities in the value of this counter can occur at
      re-initialization of the management system, and at other times
      as indicated by the value of the 'discontinuity-time' leaf
      defined in the ietf-interfaces YANG module (IETF RFC 8343).";

    reference
      "IEEE Std 802.3, 30.5.1.1.14";
  }

  leaf fec-buffer-head-coding-violations {
    type yang:counter64;

    units code-group;

    config false;
  }
}

```

description

"For 1G-EPON PHY, this object represents the count of the number of invalid code-groups received directly from the link when FEC is enabled. When FEC is disabled this counter stops counting.

For 10G-EPON PHYs, this object is set to zero.

This object is applicable for an OLT and an ONU. It has a distinct value for each logical link.

Discontinuities in the value of this counter can occur at re-initialization of the management system, and at other times as indicated by the value of the 'discontinuity-time' leaf defined in the ietf-interfaces YANG module (IETF RFC 8343).";

reference

"IEEE Std 802.3.1, dot3EponFecBufferHeadCodingViolation";

}

leaf fec-code-word-corrected-errors {  
  type yang:counter64;

  units code-group;

  config false;

  description

  "For 1G-EPON or 10G-EPON PHYs, this object represents a count of corrected FEC blocks.

  This counter increments by one for each received FEC block that contained detected errors and was corrected by the FEC function in the PHY.

  This object is applicable for an OLT and an ONU. It has a distinct value for each logical link.

  Discontinuities in the value of this counter can occur at re-initialization of the management system, and at other times as indicated by the value of the 'discontinuity-time' leaf defined in the ietf-interfaces YANG module (IETF RFC 8343).";

  reference

  "IEEE Std 802.3, 30.5.1.1.17";

  }

leaf fec-code-word-uncorrected-errors {  
  type yang:counter64;

  units code-group;

  config false;

  description

  "For 1G-EPON or 10G-EPON PHYs, this object represents a count of uncorrectable FEC blocks.

IEEE Std 802.3.2-2019  
IEEE Standard for Ethernet YANG Data Model Definitions

This counter increments by one for each received FEC block that contained detected errors and was not corrected by the FEC function in the PHY.

This object is applicable for an OLT and an ONU. It has a distinct value for each logical link.

Discontinuities in the value of this counter can occur at re-initialization of the management system, and at other times as indicated by the value of the 'discontinuity-time' leaf defined in the ietf-interfaces YANG module (IETF RFC 8343).";

```

reference
  "IEEE Std 802.3, 30.5.1.1.18";
}
}

container mpcp-logical-link-admin-actions {
  description
    "Container of actions.";
  action state-change-action-type {
    description
      "Request a state change on the interface.";
    input {
      leaf state-change-action-type {
        type identityref {
          base state-change-action-type;
        }
      }
      description
        "Type of interface state change requested.";
    }
  }
}

action reset-action-type {
  description
    "Request a reset-action of the interface.";
  input {
    leaf reset-action-type {
      type identityref {
        base reset-action-type;
      }
    }
    description
      "Type of reset action requested of the interface.";
  }
}

action register-type {
  description
    "Request a registration action.";
  input {
    leaf register-type {
      type identityref {
        base register-type;
      }
    }
    description
      "Type of registration action requested of the interface.";
  }
}
}

```



IEEE Std 802.3.2-2019  
IEEE Standard for Ethernet YANG Data Model Definitions

Although the REPORT MPCPDU can report current occupation for up to 8 upstream transmission queues in a single REPORT MPCPDU, the actual number is flexible. The 'mcp-queue-group' grouping has a variable size that is limited by value of 'mcp-maximum-queue-count-per-report' object, allowing ONUs report the occupancy of fewer upstream transmission queues, as needed.

This object is applicable for an OLT and an ONU. At the OLT, this object has a distinct value for each logical link and every queue. At the ONU, it has a distinct value for every queue.";

reference

"IEEE Std 802.3.1, dot3ExtPkgQueueEntry";

leaf mcp-queue-index {

type uint8 {

range "0 .. 7" {

description

"This object indicates the identity (index) of a queue in the ONU. It can have a value between 0 and 7, limited by the value stored in the 'mcp-maximum-queue-count-per-report' object.";

reference

"See 'mcp-maximum-queue-count-per-report' object";

}  
}

description

"An object represents the index of an upstream transmission queue storing subscriber packets. The size (occupancy) of the upstream transmission queue identified by this object is then reported within REPORT MPCPDU, defined in IEEE Std 802.3, Clause 64 and Clause 77.

This object indicates the identity (index) of a queue in the ONU. It can have a value between 0 and 7, limited by the value stored in the 'mcp-maximum-queue-count-per-report' object.

This object is applicable for an OLT and an ONU. It has a distinct value for each logical link and each queue. At the ONU, it has a distinct value for each queue.";

reference

"IEEE Std 802.3.1, dot3QueueIndex";

}

leaf mcp-queue-threshold-count {

type uint8 {

range "0 .. 7" {

description

"This object indicates the identity (index) of a queue in the ONU. It can have a value between 0 and 7, limited by the value stored in the 'mcp-maximum-queue-count-per-report' object.";

reference

```

        "See 'mpcp-queue-threshold-count-max' object";
    }
}

description
    "This object reflects the number of reporting thresholds for
    the specific upstream transmission queue, reflected in the
    REPORT MPCPDU, as defined in IEEE Std 802.3,
    Clause 64 and Clause 77.

    Each 'Queue set' provides information for the specific
    upstream transmission queue occupancy of frames below the
    matching reporting threshold.

    A read of this object reflects the number of reporting
    thresholds for the specific upstream transmission queue.

    This object is applicable for an OLT and an ONU. It has a
    distinct value for each logical link and each queue.
    At the ONU, it has a distinct value for each queue.";

reference
    "IEEE Std 802.3.1, dot3ExtPkgObjectReportNumThreshold";
}

leaf mpcp-queue-threshold-count-max {
    type uint8 {
        range "0 .. 7" {
            description
                "This object can have a value between 0 and 7.";
        }
    }
    config false;
    description
        "This object reflects the maximum number of reporting
        thresholds for the specific upstream transmission queue,
        reflected in the REPORT MPCPDU, as defined in
        IEEE Std 802.3, Clause 64 and Clause 77.

        A read of this object reflects the maximum number of
        reporting thresholds for the specific upstream transmission
        queue.

        This object is applicable for an OLT and an ONU. It has a
        distinct value for each logical link and each queue.
        At the ONU, it has a distinct value for each queue.";

    reference
        "IEEE Std 802.3.1, dot3ExtPkgObjectReportMaximumNumThreshold";
}

list mpcp-queue-thresholds {
    when "../mpcp-queue-threshold-count > 0";

    key mpcp-queue-set-index;

    max-elements 7;

    description

```

IEEE Std 802.3.2-2019  
IEEE Standard for Ethernet YANG Data Model Definitions

"An instance of this object for each value of 'mpcp-queue-index' is created when a new logical link is registered and deleted when the logical link is deregistered.

All instances of this object in the ONU associated with the given logical link are then mapped to a REPORT MPCPDU, when generated.

Destination Address	
Source Address	
Length/Type	
OpCode	
TimeStamp	
Number of Queue Sets	
Report bitmap	
Queue 0 report	
Queue 1 report	repeated for every Queue Set
Queue 2 report	
Queue 3 report	
Queue 4 report	
Queue 5 report	
Queue 6 report	
Queue 7 report	
Pad/reserved	
FCS	

The 'Queue N report' field reports the current occupancy of each upstream transmission queue associated with the given logical link.

The 'Number of Queue Sets' field defines the number of reported 'Queue N report' sets.

For each Queue Set, the 'Report bitmap' field defines which upstream transmission queues are present in the REPORT MPCPDU. Although the REPORT MPCPDU can report current occupation for up to 8 upstream transmission queues in a single REPORT MPCPDU, the actual number is flexible.

The 'mpcp-queue-group' grouping has a variable size that is

limited by value of 'mcpq-maximum-queue-count-per-report' object, allowing ONUs to report the occupancy of fewer upstream transmission queues, as needed.

This object is applicable for an OLT and an ONU. It has a distinct value for each logical link and every queue. At the ONU, it has a distinct value for every queue.";

reference

"IEEE Std 802.3.1, dot3ExtPkgQueueSetsEntry";

leaf mpcp-queue-set-index {

type uint8 {

range "0 .. 7" {

description

"This object indicates the identity (index) of a queue in the ONU. It can have a value between 0 and 7, limited by the value stored in the 'mcpq-maximum-queue-count-per-report' object.";

reference

"See 'mcpq-maximum-queue-count-per-report' object";

}  
}

description

"This object represents the index of the Queue Set for the 'mcpq-queue-set-group' grouping. The size (occupancy) of the upstream transmission queues belonging to the given Queue Set is then reported within REPORT MPCPDU, defined in IEEE Std 802.3, Clause 64 and Clause 77.

This object can have a value between 0 and 7, limited by the value stored in the 'mcpq-queue-threshold-count-max' object.";

reference

"IEEE Std 802.3.1, dot3QueueSetIndex";

}

leaf mpcp-queue-set-threshold {

type uint64;

units "TQ";

default "0";

description

"This object defines the value of a reporting threshold for each Queue Set stored in REPORT MPCPDU defined in IEEE Std 802.3, Clause 64 and Clause 77.

The number of Queue Sets for each upstream transmission queue is defined in the 'mcpq-queue-threshold-count' object.

Within REPORT MPCPDU, each Queue Set provides information on the current upstream transmission queue occupancy for frames below the matching threshold.

IEEE Std 802.3.2-2019  
IEEE Standard for Ethernet YANG Data Model Definitions

The value stored in this object is expressed in the units of Time quanta (TQ), where 1 TQ = 16 ns.

A read of this object provides the current threshold value for the specific upstream transmission queue.

This object is applicable for an OLT and an ONU. At the OLT, it has a distinct value for each logical link, each queue, and each Queue Set.

At the ONU, it has a distinct value for each queue and each Queue Set.";

```

reference
  "IEEE Std 802.3.1, dot3ExtPkgObjectReportThreshold";
}
}

leaf in-mpcp-queue-frames {
  type yang:counter64;

  config false;

  description
    "A count of the number of times a frame reception event
    results in a frame being queued in (for ONUs) or received
    from (for OLTs) the corresponding queue. This object is
    incremented by one for each frame written to (in the case
    of the ONU) or received for (in case of the OLT) the
    associated queue.

    The queue index matches the queue number in REPORT MPCPDU,
    as defined in IEEE Std 802.3, Clause 64 and Clause 77.

    This object is applicable for an OLT and an ONU. At the OLT,
    it has a distinct value for each logical link and each queue.
    At the ONU, it has a distinct value for each queue.

    Discontinuities in the value of this counter can occur at
    re-initialization of the management system, and at other times
    as indicated by the value of the 'discontinuity-time' leaf
    defined in the ietf-interfaces YANG module (IETF RFC 8343).";

  reference
    "IEEE Std 802.3.1, dot3ExtPkgStatRxFramesQueue";
}

leaf out-mpcp-queue-frames {
  when "../mpcp-mode = 'onu'";

  type yang:counter64;

  config false;

  description
    "This object reflects the number of frame transmission
    events from the corresponding upstream transmission queue.
    This object is incremented by one for each frame transmitted
  
```

, when it is output from the associated queue.

The queue index matches the queue number in REPORT MPCPDU, as defined in IEEE Std 802.3, Clause 64 and Clause 77.

This object is applicable for an ONU only. At the ONU, it has a distinct value for each queue.

Discontinuities in the value of this counter can occur at re-initialization of the management system, and at other times as indicated by the value of the 'discontinuity-time' leaf defined in the ietf-interfaces YANG module (IETF RFC 8343).";

```

reference
  "IEEE Std 802.3.1, dot3ExtPkgStatTxFramesQueue";
}

leaf mpcp-queue-frames-drop {
  when "../mpcp-mode = 'onu'";

  type yang:counter64;

  config false;

  description
    "This object reflects the number of frame drop events from
    the corresponding upstream transmission queue. This object
    is incremented by one for each frame dropped in the
    associated queue.

    The queue index matches the queue number in REPORT MPCPDU,
    as defined in IEEE Std 802.3, Clause 64 and Clause 77.

    This object is applicable for an ONU only. At the ONU, it
    has a distinct value for each queue.

    Discontinuities in the value of this counter can occur at
    re-initialization of the management system, and at other times
    as indicated by the value of the 'discontinuity-time' leaf
    defined in the ietf-interfaces YANG module (IETF RFC 8343).";

  reference
    "IEEE Std 802.3.1, dot3ExtPkgStatDroppedFramesQueue";
}

list multicast-IDs {
  key multicast-ID;
  description
    "Multicast-IDs list of multicast IDs
    to be recognized by the device.";
  leaf multicast-ID {
    type uint32;
    description
      "Multicast-IDs to be recognized by the device.";
  }
  reference
    "IEEE Std 802.3, 30.3.5.1.25";
}
}

```

IEEE Std 802.3.2-2019  
IEEE Standard for Ethernet YANG Data Model Definitions

```

leaf fec-capability {
  type fec-capability;

  config false;

  description
    "This object is used to identify whether the given interface
    is capable of supporting FEC or not.";
}

leaf mpcp-mode {
  type mpcp-mode;

  config false;

  description
    "This object is used to identify the operational state of the
    MultiPoint MAC Control sublayer as defined in
    IEEE Std 802.3, Clause 64 and Clause 77.

    Reading 'olt' for an OLT (controller) mode and 'onu' for an ONU
    (client) mode.

    This object is used to identify the operational mode for the
    MPCP objects.

    This object is applicable for an OLT, with the same value for
    all logical links, and for an ONU."

  reference
    "IEEE Std 802.3, 30.3.5.1.3"
}

leaf mpcp-sync-time {
  type uint64;

  units "TQ (16ns)";

  config false;

  description
    "This object reports the 'sync lock time' of the OLT
    receiver in units of Time Quanta (TQ; 1 TQ = 16 ns; see
    IEEE Std 802.3, Clause 64 and Clause 77).

    The value returned is equal to [sync lock time ns]/16,
    rounded up to the nearest TQ. If this value exceeds
    4,294,967,295 TQ, the value 4,294,967,295 TQ is returned.

    This object is applicable for an OLT, with distinct values for
    all logical links, and for an ONU."

  reference
    "IEEE Std 802.3.1, dot3MpcpSyncTime";
}

leaf mpcp-logical-link-id {
  type mpcp-supported;

```

```

config false;

description
  "This object is used to identify the operational state of the
  MultiPoint MAC Control sublayer as defined in
  IEEE Std 802.3, Clause 64 and Clause 77.

  Reading 'olt' for an OLT (controller) mode and 'onu' for an ONU
  (client) mode.

  This object is used to identify the operational mode for the
  MPCP objects.

  This object is applicable for an OLT, with the same value for
  all logical links, and for an ONU."

reference
  "IEEE Std 802.3, 30.3.5.1.3";
}

leaf mpcp-remote-mac-address {
  type yang:mac-address;

  config false;

  description
    "This object identifies the source address parameter of the
    last MPCPDUs passed to the MAC Control. This value is updated
    on reception of a valid frame with:

    1) a destination Field equal to the multicast address assigned
    for MAC Control as specified in IEEE Std 802.3, Annex 31A;

    2) the lengthOrType field value equal to the Type assigned for
    MAC Control as specified in IEEE Std 802.3, Annex 31A;

    3) an MPCP Control opcode value equal to the subtype assigned
    for MPCP as specified in IEEE Std 802.3, Annex 31A.

    This object is applicable for an OLT and an ONU. It has a
    distinct value for each logical link.

    The value reflects the MAC address of the remote entity and
    therefore the OLT holds a value for each LLID, which is
    the MAC address of the ONU.

    The ONU has a single value that is the OLT MAC address."

  reference
    "IEEE Std 802.3, 30.3.5.1.5";
}

leaf mpcp-logical-link-state {
  type mpcp-logical-link-state;

  config false;

  description

```

IEEE Std 802.3.2-2019  
IEEE Standard for Ethernet YANG Data Model Definitions

"This object identifies the registration state of the MultiPoint MAC Control sublayer as defined in IEEE Std 802.3, Clause 64 and Clause 77.

When this object has the enumeration 'unregistered', the interface is unregistered and may be used for registering a link partner.

When this object has the enumeration 'registering', the interface is in the process of registering a link-partner.

When this object has the enumeration 'registered', the interface has an established link-partner.

This object is applicable for an OLT and an ONU. It has a distinct value for each logical link.";

```

reference
  "IEEE Std 802.3, 30.3.5.1.6";
}

leaf mpcp-elapsed-time-out {
  type uint64;

  units "TQ (16ns)";

  config false;

  description
    "This object reports the interval from the last MPCP frame
    transmission in increments of Time Quanta (TQ; 1 TQ = 16 ns;
    see IEEE Std 802.3, Clause 64 and Clause 77).

    The value returned is equal to [interval from last MPCP
    frame transmission on this EPON interface, expressed
    in ns]/16. If this value exceeds 4,294,967,295 TQ, the value
    4,294,967,295 TQ is returned.

    This object is applicable for an OLT and an ONU. It has a
    distinct value for each logical link.";

  reference
    "IEEE Std 802.3, 30.3.5.1.19";
}

leaf mpcp-elapsed-time-in {
  type uint64;

  units "TQ (16ns)";

  config false;

  description
    "This object reports the interval from the last MPCP frame
    reception in increments of Time Quanta (TQ; 1 TQ = 16 ns; see
    IEEE Std 802.3, Clause 64 and Clause 77).

    The value returned is equal to [interval from last MPCP
    frame reception on this EPON interface, expressed in

```

ns]/16. If this value exceeds 4,294,967,295 TQ, the value 4,294,967,295 TQ is returned.

This object is applicable for an OLT and an ONU. It has a distinct value for each logical link.";

```

reference
  "IEEE Std 802.3, 30.3.5.1.20";
}

leaf mpcp-round-trip-time {
  when "../ompe-mode = 'olt'";
  type uint16;

  units "TQ (16ns)";

  config false;

  description
    "This object reports the MPCP round trip time in increments
    of Time Quanta (TQ; 1 TQ = 16 ns; see IEEE Std 802.3,
    Clause 64 and Clause 77).

    The value returned is equal to [round trip time in ns]/16.
    If this value exceeds 65,535 TQ, the value 65,535 TQ is
    returned.

    This object is applicable for an OLT. It has a distinct value
    for each logical link.";

  reference
    "IEEE Std 802.3, 30.3.5.1.21";
}

leaf mpcp-maximum-grant-count {
  when "../ompe-mode = 'onu'";
  type uint8;

  config false;

  description
    "This object reports the maximum number of grants that an
    ONU can store for handling. The maximum number of grants that
    an ONU can store for handling has a range of 0 to 255.

    This object is applicable for an ONU and has a distinct value
    for each logical link.";

  reference
    "IEEE Std 802.3, 30.3.5.1.24";
}

leaf mpcp-logical-link-count {
  type mpcp-llid-count;

  units LLID;

  config false;

```

IEEE Std 802.3.2-2019  
IEEE Standard for Ethernet YANG Data Model Definitions

## description

"This object reflects the number of logical links registered on the OLT / ONU. The LLID field, as defined in the IEEE Std 802.3, Clause 65 and Clause 76, is a 2-byte register (15-bit field and a broadcast bit) limiting the number of logical links to 32,768.

This object is initialized to the value of 0 when the OLT / ONU is powered up.

This object is applicable for an OLT and an ONU. It has the same value for all logical links.";

## reference

"IEEE Std 802.3.1, dot3ExtPkgObjectNumberOfLLIDs";

}

```
leaf mpcp-maximum-queue-count-per-report {
  when "../ompe-mode = olt";
  type mpcp-maximum-queue-count-per-report;

```

config false;

## description

"This object reflects the maximum number of queues (0-7) that can be accepted by the OLT in a single REPORT MPCPDU, as defined in IEEE Std 802.3, Clause 64 and Clause 77.

This object is applicable for an OLT and has a distinct value for each logical link.";

## reference

"IEEE Std 802.3.1, dot3ExtPkgObjectReportMaximumNumQueues";

}

```
leaf ompe-mode {
  type ompe-mode;

```

config false;

## description

"This object indicates the mode of operation of the Reconciliation Sublayer for Point-to-Point Emulation (see IEEE Std 802.3, 65.1 or 76.2 as appropriate).

The value of 'unknown' is assigned in initialization; true state or type is not yet known.

The value of 'olt' is assigned when the sublayer is operating in OLT mode.

The value of 'onu' is assigned when the sublayer is operating in ONU mode.

This object is applicable for an OLT and an ONU. It has the same value for each logical link.";

## reference

"IEEE Std 802.3, 30.3.7.1.2";

```
}  
}  
}
```

IECNORM.COM : Click to view the full PDF of ISO/IEC/IEEE 8802-3-2:2021