**Industrial automation systems and
integration — Product data representation
and exchange —**

Part 212:

**Application protocol: Electrotechnical
design and installation**

*Systèmes d'automatisation industrielle et intégration — Représentation et
échange de données de produits —*

*Partie 212: Protocole d'application: Conception électrotechnique et
installation*

PDF disclaimer

This PDF file may contain embedded typefaces. In accordance with Adobe's licensing policy, this file may be printed or viewed but shall not be edited unless the typefaces which are embedded are licensed to and installed on the computer performing the editing. In downloading this file, parties accept therein the responsibility of not infringing Adobe's licensing policy. The ISO Central Secretariat accepts no liability in this area.

Adobe is a trademark of Adobe Systems Incorporated.

Details of the software products used to create this PDF file can be found in the General Info relative to the file; the PDF-creation parameters were optimized for printing. Every care has been taken to ensure that the file is suitable for use by ISO member bodies. In the unlikely event that a problem relating to it is found, please inform the Central Secretariat at the address given below.

STANDARDSISO.COM : Click to view the full PDF of ISO 10303-212:2001

© ISO 2001

All rights reserved. Unless otherwise specified, no part of this publication may be reproduced or utilized in any form or by any means, electronic or mechanical, including photocopying and microfilm, without permission in writing from either ISO at the address below or ISO's member body in the country of the requester.

ISO copyright office
Case postale 56 • CH-1211 Geneva 20
Tel. + 41 22 749 01 11
Fax + 41 22 749 09 47
E-mail copyright@iso.ch
Web www.iso.ch

Printed in Switzerland

Contents

	Page
1 Scope.....	1
2 Normative references.....	3
3 Terms, definitions, and abbreviations.....	5
3.1 Terms defined in IEC 61082-1.....	5
3.2 Terms defined in ISO 10303-1.....	5
3.3 Terms defined in ISO 10303-31.....	6
3.4 Terms defined in ISO 10303-42.....	6
3.5 Terms defined in ISO 10303-44.....	6
3.6 Terms defined in ISO 10303-46.....	6
3.7 Other terms and definitions.....	6
3.8 Abbreviations.....	10
4 Information requirements.....	11
4.1 Units of functionality.....	11
4.1.1 allocation (AL1).....	12
4.1.2 classification (CA1).....	12
4.1.3 conditions (CD1).....	13
4.1.4 configuration_management (CF1).....	13
4.1.5 course (CO1).....	14
4.1.6 designation (DE1).....	15
4.1.7 dimensioned_documentation (DI1).....	15
4.1.8 documentation (DO1).....	16
4.1.9 effectivity_data (EF1).....	19
4.1.10 external_reference (ER1).....	19
4.1.11 function_structure (F1).....	21
4.1.12 functional_connectivity (FC1).....	21

ISO 10303-212:2001(E)

4.1.13	installation (IN1)	22
4.1.14	messages (M1)	24
4.1.15	network_allocation (NA1)	24
4.1.16	organizational_data (OD1)	25
4.1.17	physical_connectivity (PC1)	25
4.1.18	product_structure (PD1)	27
4.1.19	properties (PR1)	28
4.1.20	remark (R1)	30
4.1.21	schematic_documentation (SC1)	30
4.1.22	site (SI1)	31
4.1.23	work_management (W1)	31
4.2	Application objects	32
4.3	Application assertions	403
5	Application interpreted model	664
5.1	Mapping table	664
5.2	AIM EXPRESS short listing	1644
6	Conformance requirements	2012
6.1	Conformance class for Design_physical_characterization (CC 1)	2013
6.2	Conformance class for Design_characterization (CC 2)	2013
6.3	Conformance class for Spatial_arrangement (CC 3)	2013
6.4	Conformance class for Design_characterization_and_spatial_arrangement (CC 4)	2013
6.5	Conformance class for Spatial_arrangement_and_configuration_data (CC 5)	2013
6.6	Conformance class for Documented_design_characterization (CC 6)	2014
6.7	Conformance class for Documented_item_characterization (CC 7)	2014
6.8	Conformance class for Complete_system_characterization (CC 8)	2014
6.9	Conformance class for Product_structure_and_work_management_data (CC 9)	2014
6.10	Conformance class for Design_structure_and_work_mnagement_data (CC 10)	2014
6.11	Conformance class for Location_information_and_work_management_data (CC 11)	2014
6.12	Conformance class for Design_structure_and_configuration_data (CC 12)	2014
6.13	Conformance class for Item_structure_and_configuration_data (CC 13)	2014
6.14	Conformance class for Documented_design_structure_and_configuration_data (CC 14)	2014
6.15	Conformance class for Documented_item_structure_and_configuration_data (CC 15)	2015
Annex A (normative)	AIM EXPRESS expanded listing	2097
Annex B (normative)	AIM short names	2385

Annex C (normative) Implementation method specific requirements	2412
Annex D (normative) Protocol Implementation Conformance Statement (PICS) proforma	2413
Annex E (normative) Information object registration	2416
E.1 Document identification	2416
E.2 Schema identification	2416
Annex F (informative) Application activity model	2417
F.1 Application activity model definitions and abbreviations	2417
F.2 Application activity model diagrams	2426
Annex G (informative) Application reference model	2439
Annex H (informative) AIM EXPRESS-G	2533
Annex J (informative) Computer interpretable listings	2630
Bibliography	2631
Index	2632

Figures

Figure 1 - Electrical equipment in a tramcar	xiv
Figure 2 - Product data that characterizes industrial electrotechnical equipment	xvi
Figure 3 - Data planning model	xviii
Figure 4 - Functionality of a gas - insulated switchgear	22
Figure 5 - Example of an installation; installation of devices on cabletrays or in cabinets	23
Figure 6 - Example of a product description; outcut of a wiring harness	26
Figure 7 - Hierarchical composition	64
Figure 8 - Configuration inheritance scheme	91
Figure 9 - Connection_bundle of Connection objects	94
Figure 10 - Predefined corner styles	102
Figure 11 - Predefined curve end styles	103
Figure 12 - Predefined dimension symbols	133
Figure 13 - Power transformer fed through an overhead cable	186
Figure 14 - Predefined geometrical tolerance symbols	205
Figure 15 - Internally wired connector	219
Figure 16 - Predefined point marker symbols	280

ISO 10303-212:2001(E)

Figure 17 - Predefined section end shapes.....	333
Figure 18 - Predefined terminator symbols.....	375
Figure 19 - Text characteristics.....	379
Figure 20 - Mirror angle.....	381
Figure 21 - Text appearance and rotation of text.....	383
Figure F.1 - AAM diagram of node A-0: Electrotechnical design and installation.....	2426
Figure F.2 - AAM diagram of node A0: Engineer electrotechnical system	2427
Figure F.3 - AAM diagram of node A1: Identify system.....	2428
Figure F.4 - AAM diagram of node A2: Develop conceptual design.....	2430
Figure F.5 - AAM diagram of node A3: Develop system.....	2431
Figure F.6 - AAM diagram of node A4: Implement system	2432
Figure F.7 - AAM diagram of node A5: Put system into operation	2433
Figure G.1 - ARM diagram in EXPRESS-G: 1 of 93	2440
Figure G.2 - ARM diagram in EXPRESS-G: 2 of 93	2441
Figure G.3 - ARM diagram in EXPRESS-G: 3 of 93	2442
Figure G.4 - ARM diagram in EXPRESS-G: 4 of 93	2443
Figure G.5 - ARM diagram in EXPRESS-G: 5 of 93	2444
Figure G.6 - ARM diagram in EXPRESS-G: 6 of 93.....	2445
Figure G.7 - ARM diagram in EXPRESS-G: 7 of 93	2446
Figure G.8 - ARM diagram in EXPRESS-G: 8 of 93	2447
Figure G.9 - ARM diagram in EXPRESS-G: 9 of 93	2448
Figure G.10 - ARM diagram in EXPRESS-G: 10 of 93	2449
Figure G.11 - ARM diagram in EXPRESS-G: 11 of 93	2450
Figure G.12 - ARM diagram in EXPRESS-G: 12 of 93	2451
Figure G.13 - ARM diagram in EXPRESS-G: 13 of 93	2452
Figure G.14 - ARM diagram in EXPRESS-G: 14 of 93	2453
Figure G.15 - ARM diagram in EXPRESS-G: 15 of 93	2454
Figure G.16 - ARM diagram in EXPRESS-G: 16 of 93	2455
Figure G.17 - ARM diagram in EXPRESS-G: 17 of 93	2456
Figure G.18 - ARM diagram in EXPRESS-G: 18 of 93	2457
Figure G.19 - ARM diagram in EXPRESS-G: 19 of 93	2458
Figure G.20 - ARM diagram in EXPRESS-G: 20 of 93	2459
Figure G.21 - ARM diagram in EXPRESS-G: 21 of 93	2460
Figure G.22 - ARM diagram in EXPRESS-G: 22 of 93	2461
Figure G.23 - ARM diagram in EXPRESS-G: 23 of 93	2462

Figure G.24 - ARM diagram in EXPRESS-G: 24 of 93	2463
Figure G.25 - ARM diagram in EXPRESS-G: 25 of 93	2464
Figure G.26 - ARM diagram in EXPRESS-G: 26 of 93	2465
Figure G.27 - ARM diagram in EXPRESS-G: 27 of 93	2466
Figure G.28 - ARM diagram in EXPRESS-G: 28 of 93	2467
Figure G.29 - ARM diagram in EXPRESS-G: 29 of 93	2468
Figure G.30 - ARM diagram in EXPRESS-G: 30 of 93	2469
Figure G.31 - ARM diagram in EXPRESS-G: 31 of 93	2470
Figure G.32 - ARM diagram in EXPRESS-G: 32 of 93	2471
Figure G.33 - ARM diagram in EXPRESS-G: 33 of 93	2472
Figure G.34 - ARM diagram in EXPRESS-G: 34 of 93	2473
Figure G.35 - ARM diagram in EXPRESS-G: 35 of 93	2474
Figure G.36 - ARM diagram in EXPRESS-G: 36 of 93	2475
Figure G.37 - ARM diagram in EXPRESS-G: 37 of 93	2476
Figure G.38 - ARM diagram in EXPRESS-G: 38 of 93	2477
Figure G.39 - ARM diagram in EXPRESS-G: 39 of 93	2478
Figure G.40 - ARM diagram in EXPRESS-G: 40 of 93	2479
Figure G.41 - ARM diagram in EXPRESS-G: 41 of 93	2480
Figure G.42 - ARM diagram in EXPRESS-G: 42 of 93	2481
Figure G.43 - ARM diagram in EXPRESS-G: 43 of 93	2482
Figure G.44 - ARM diagram in EXPRESS-G: 44 of 93	2483
Figure G.45 - ARM diagram in EXPRESS-G: 45 of 93	2484
Figure G.46 - ARM diagram in EXPRESS-G: 46 of 93	2485
Figure G.47 - ARM diagram in EXPRESS-G: 47 of 93	2486
Figure G.48 - ARM diagram in EXPRESS-G: 48 of 93	2487
Figure G.49 - ARM diagram in EXPRESS-G: 49 of 93	2488
Figure G.50 - ARM diagram in EXPRESS-G: 50 of 93	2489
Figure G.51 - ARM diagram in EXPRESS-G: 51 of 93	2490
Figure G.52 - ARM diagram in EXPRESS-G: 52 of 93	2491
Figure G.53 - ARM diagram in EXPRESS-G: 53 of 93	2492
Figure G.54 - ARM diagram in EXPRESS-G: 54 of 93	2493
Figure G.55 - ARM diagram in EXPRESS-G: 55 of 93	2494
Figure G.56 - ARM diagram in EXPRESS-G: 56 of 93	2495
Figure G.57 - ARM diagram in EXPRESS-G: 57 of 93	2496
Figure G.58 - ARM diagram in EXPRESS-G: 58 of 93	2497

ISO 10303-212:2001(E)

Figure G.59 - ARM diagram in EXPRESS-G: 59 of 93	2498
Figure G.60 - ARM diagram in EXPRESS-G: 60 of 93	2499
Figure G.61 - ARM diagram in EXPRESS-G: 61 of 93	2500
Figure G.62 - ARM diagram in EXPRESS-G: 62 of 93	2501
Figure G.63 - ARM diagram in EXPRESS-G: 63 of 93	2502
Figure G.64 - ARM diagram in EXPRESS-G: 64 of 93	2503
Figure G.65 - ARM diagram in EXPRESS-G: 65 of 93	2504
Figure G.66 - ARM diagram in EXPRESS-G: 66 of 93	2505
Figure G.67 - ARM diagram in EXPRESS-G: 67 of 93	2506
Figure G.68 - ARM diagram in EXPRESS-G: 68 of 93	2507
Figure G.69 - ARM diagram in EXPRESS-G: 69 of 93	2508
Figure G.70 - ARM diagram in EXPRESS-G: 70 of 93	2509
Figure G.71 - ARM diagram in EXPRESS-G: 71 of 93	2510
Figure G.72 - ARM diagram in EXPRESS-G: 72 of 93	2511
Figure G.73 - ARM diagram in EXPRESS-G: 73 of 93	2512
Figure G.74 - ARM diagram in EXPRESS-G: 74 of 93	2513
Figure G.75 - ARM diagram in EXPRESS-G: 75 of 93	2514
Figure G.76 - ARM diagram in EXPRESS-G: 76 of 93	2515
Figure G.77 - ARM diagram in EXPRESS-G: 77 of 93	2516
Figure G.78 - ARM diagram in EXPRESS-G: 78 of 93	2517
Figure G.79 - ARM diagram in EXPRESS-G: 79 of 93	2518
Figure G.80 - ARM diagram in EXPRESS-G: 80 of 93	2519
Figure G.81 - ARM diagram in EXPRESS-G: 81 of 93	2520
Figure G.82 - ARM diagram in EXPRESS-G: 82 of 93	2521
Figure G.83 - ARM diagram in EXPRESS-G: 83 of 93	2522
Figure G.84 - ARM diagram in EXPRESS-G: 84 of 93	2523
Figure G.85 - ARM diagram in EXPRESS-G: 85 of 93	2524
Figure G.86 - ARM diagram in EXPRESS-G: 86 of 93	2525
Figure G.87 - ARM diagram in EXPRESS-G: 87 of 93	2526
Figure G.88 - ARM diagram in EXPRESS-G: 88 of 93	2527
Figure G.89 - ARM diagram in EXPRESS-G: 89 of 93	2528
Figure G.90 - ARM diagram in EXPRESS-G: 90 of 93	2529
Figure G.91 - ARM diagram in EXPRESS-G: 91 of 93	2530
Figure G.92 - ARM diagram in EXPRESS-G: 92 of 93	2531
Figure G.93 - ARM diagram in EXPRESS-G: 93 of 93	2532

Figure H.1 - AIM diagram in EXPRESS-G: 1 of 96.....	2534
Figure H.2 - AIM diagram in EXPRESS-G: 2 of 96.....	2535
Figure H.3 - AIM diagram in EXPRESS-G: 3 of 96.....	2536
Figure H.4 - AIM diagram in EXPRESS-G: 4 of 96.....	2537
Figure H.5 - AIM diagram in EXPRESS-G: 5 of 96.....	2538
Figure H.6 - AIM diagram in EXPRESS-G: 6 of 96.....	2539
Figure H.7 - AIM diagram in EXPRESS-G: 7 of 96.....	2540
Figure H.8 - AIM diagram in EXPRESS-G: 8 of 96.....	2541
Figure H.9 - AIM diagram in EXPRESS-G: 9 of 96.....	2542
Figure H.10 - AIM diagram in EXPRESS-G: 10 of 96.....	2543
Figure H.11 - AIM diagram in EXPRESS-G: 11 of 96.....	2544
Figure H.12 - AIM diagram in EXPRESS-G: 12 of 96.....	2545
Figure H.13 - AIM diagram in EXPRESS-G: 13 of 96.....	2546
Figure H.14 - AIM diagram in EXPRESS-G: 14 of 96.....	2547
Figure H.15 - AIM diagram in EXPRESS-G: 15 of 96.....	2548
Figure H.16 - AIM diagram in EXPRESS-G: 16 of 96.....	2549
Figure H.17 - AIM diagram in EXPRESS-G: 17 of 96.....	2550
Figure H.18 - AIM diagram in EXPRESS-G: 18 of 96.....	2551
Figure H.19 - AIM diagram in EXPRESS-G: 19 of 96.....	2552
Figure H.20 - AIM diagram in EXPRESS-G: 20 of 96.....	2553
Figure H.21 - AIM diagram in EXPRESS-G: 21 of 96.....	2554
Figure H.22 - AIM diagram in EXPRESS-G: 22 of 96.....	2555
Figure H.23 - AIM diagram in EXPRESS-G: 23 of 96.....	2556
Figure H.24 - AIM diagram in EXPRESS-G: 24 of 96.....	2557
Figure H.25 - AIM diagram in EXPRESS-G: 25 of 96.....	2558
Figure H.26 - AIM diagram in EXPRESS-G: 26 of 96.....	2559
Figure H.27 - AIM diagram in EXPRESS-G: 27 of 96.....	2560
Figure H.28 - AIM diagram in EXPRESS-G: 28 of 96.....	2561
Figure H.29 - AIM diagram in EXPRESS-G: 29 of 96.....	2562
Figure H.30 - AIM diagram in EXPRESS-G: 30 of 96.....	2563
Figure H.31 - AIM diagram in EXPRESS-G: 31 of 96.....	2564
Figure H.32 - AIM diagram in EXPRESS-G: 32 of 96.....	2565
Figure H.33 - AIM diagram in EXPRESS-G: 33 of 96.....	2566
Figure H.34 - AIM diagram in EXPRESS-G: 34 of 96.....	2567
Figure H.35 - AIM diagram in EXPRESS-G: 35 of 96.....	2568

ISO 10303-212:2001(E)

Figure H.36 - AIM diagram in EXPRESS-G: 36 of 96.....	2569
Figure H.37 - AIM diagram in EXPRESS-G: 37 of 96.....	2570
Figure H.38 - AIM diagram in EXPRESS-G: 38 of 96.....	2571
Figure H.39 - AIM diagram in EXPRESS-G: 39 of 96.....	2572
Figure H.40 - AIM diagram in EXPRESS-G: 40 of 96.....	2573
Figure H.41 - AIM diagram in EXPRESS-G: 41 of 96.....	2574
Figure H.42 - AIM diagram in EXPRESS-G: 42 of 96.....	2575
Figure H.43 - AIM diagram in EXPRESS-G: 43 of 96.....	2576
Figure H.44 - AIM diagram in EXPRESS-G: 44 of 96.....	2577
Figure H.45 - AIM diagram in EXPRESS-G: 45 of 96.....	2578
Figure H.46 - AIM diagram in EXPRESS-G: 46 of 96.....	2579
Figure H.47 - AIM diagram in EXPRESS-G: 47 of 96.....	2580
Figure H.48 - AIM diagram in EXPRESS-G: 48 of 96.....	2581
Figure H.49 - AIM diagram in EXPRESS-G: 49 of 96.....	2582
Figure H.50 - AIM diagram in EXPRESS-G: 50 of 96.....	2583
Figure H.51 - AIM diagram in EXPRESS-G: 51 of 96.....	2584
Figure H.52 - AIM diagram in EXPRESS-G: 52 of 96.....	2585
Figure H.53 - AIM diagram in EXPRESS-G: 53 of 96.....	2586
Figure H.54 - AIM diagram in EXPRESS-G: 54 of 96.....	2587
Figure H.55 - AIM diagram in EXPRESS-G: 55 of 96.....	2588
Figure H.56 - AIM diagram in EXPRESS-G: 56 of 96.....	2589
Figure H.57 - AIM diagram in EXPRESS-G: 57 of 96.....	2590
Figure H.58 - AIM diagram in EXPRESS-G: 58 of 96.....	2591
Figure H.59 - AIM diagram in EXPRESS-G: 59 of 96.....	2592
Figure H.60 - AIM diagram in EXPRESS-G: 60 of 96.....	2593
Figure H.61 - AIM diagram in EXPRESS-G: 61 of 96.....	2594
Figure H.62 - AIM diagram in EXPRESS-G: 62 of 96.....	2595
Figure H.63 - AIM diagram in EXPRESS-G: 63 of 96.....	2596
Figure H.64 - AIM diagram in EXPRESS-G: 64 of 96.....	2597
Figure H.65 - AIM diagram in EXPRESS-G: 65 of 96.....	2598
Figure H.66 - AIM diagram in EXPRESS-G: 66 of 96.....	2599
Figure H.67 - AIM diagram in EXPRESS-G: 67 of 96.....	2600
Figure H.68 - AIM diagram in EXPRESS-G: 68 of 96.....	2601
Figure H.69 - AIM diagram in EXPRESS-G: 69 of 96.....	2602
Figure H.70 - AIM diagram in EXPRESS-G: 70 of 96.....	2603

Figure H.71 - AIM diagram in EXPRESS-G: 71 of 96.....	2604
Figure H.72 - AIM diagram in EXPRESS-G: 72 of 96.....	2605
Figure H.73 - AIM diagram in EXPRESS-G: 73 of 96.....	2606
Figure H.74 - AIM diagram in EXPRESS-G: 74 of 96.....	2607
Figure H.75 - AIM diagram in EXPRESS-G: 75 of 96.....	2608
Figure H.76 - AIM diagram in EXPRESS-G: 76 of 96.....	2609
Figure H.77 - AIM diagram in EXPRESS-G: 77 of 96.....	2610
Figure H.78 - AIM diagram in EXPRESS-G: 78 of 96.....	2611
Figure H.79 - AIM diagram in EXPRESS-G: 79 of 96.....	2612
Figure H.80 - AIM diagram in EXPRESS-G: 80 of 96.....	2613
Figure H.81 - AIM diagram in EXPRESS-G: 81 of 96.....	2614
Figure H.82 - AIM diagram in EXPRESS-G: 82 of 96.....	2615
Figure H.83 - AIM diagram in EXPRESS-G: 83 of 96.....	2616
Figure H.84 - AIM diagram in EXPRESS-G: 84 of 96.....	2617
Figure H.85 - AIM diagram in EXPRESS-G: 85 of 96.....	2618
Figure H.86 - AIM diagram in EXPRESS-G: 86 of 96.....	2619
Figure H.87 - AIM diagram in EXPRESS-G: 87 of 96.....	2620
Figure H.88 - AIM diagram in EXPRESS-G: 88 of 96.....	2621
Figure H.89 - AIM diagram in EXPRESS-G: 89 of 96.....	2622
Figure H.90 - AIM diagram in EXPRESS-G: 90 of 96.....	2623
Figure H.91 - AIM diagram in EXPRESS-G: 91 of 96.....	2624
Figure H.92 - AIM diagram in EXPRESS-G: 92 of 96.....	2625
Figure H.93 - AIM diagram in EXPRESS-G: 93 of 96.....	2626
Figure H.94 - AIM diagram in EXPRESS-G: 94 of 96.....	2627
Figure H.95 - AIM diagram in EXPRESS-G: 95 of 96.....	2628
Figure H.96 - AIM diagram in EXPRESS-G: 96 of 96.....	2629

Tables

Table 1 - RGB values for predefined colors	286
Table 2 - Line segment and space lengths for predefined curve font lists.....	287
Table 3 - AIC references for mapping tables.....	665
Table 4 - Mapping table allocation UoF	666
Table 5 - Mapping table classification UoF.....	672
Table 6 - Mapping table conditions UoF	686
Table 7 - Mapping table configuration_management UoF	705
Table 8 - Mapping table course UoF	746
Table 9 - Mapping table designation UoF	756
Table 10 - Mapping table dimensioned_documentation UoF.....	758
Table 11 - Mapping table documentation UoF	777
Table 12 - Mapping table effectivity_data UoF.....	850
Table 13 - Mapping table external_reference UoF	965
Table 14 - Mapping table function_structure UoF	1008
Table 15 - Mapping table functional_connectivity UoF.....	1020
Table 16 - Mapping table installation UoF	1027
Table 17 - Mapping table messages UoF.....	1053
Table 18 - Mapping table network_allocation UoF.....	1074
Table 19 - Mapping table organizational_data UoF	1079
Table 20 - Mapping table organizational_data UoF	1263
Table 21 - Mapping table physical_connectivity UoF.....	1285
Table 22 - Mapping table product_structure UoF.....	1295
Table 23 - Mapping table properties UoF.....	1359
Table 24 - Mapping table remark UoF.....	1443
Table 25 - Mapping table schematic_documentation UoF	1509
Table 26 - Mapping table site UoF	1546
Table 27 - Mapping table work_management UoF	1564
Table 29 - Usage of AIM elements in conformance classes.....	2019
Table B.1 - AIM short names of entities.....	2385
Table F.1 - AAM - data classes.....	2435

Foreword

ISO (the International Organization for Standardization) is a worldwide federation of national standards bodies (ISO member bodies). The work of preparing International Standards is normally carried out through ISO technical committees. Each member body interested in a subject for which a technical committee has been established has the right to be represented on that committee. International organizations, governmental and non-governmental, in liaison with ISO, also take part in the work. ISO collaborates closely with the International Electrotechnical Commission (IEC) on all matters of electrotechnical standardization.

International Standards are drafted in accordance with the rules given in the ISO/IEC Directives, Part 3.

Draft International Standards adopted by the technical committees are circulated to the member bodies for voting. Publication as an International Standard requires approval by at least 75 % of the member bodies casting a vote.

Attention is drawn to the possibility that some of the elements of this part of ISO 10303 may be the subject of patent rights. ISO shall not be held responsible for identifying any or all such patent rights.

International Standard ISO 10303-212 was prepared jointly by Technical Committee ISO/TC 184, *Industrial automation systems and integration*, Subcommittee SC 4, *Industrial data*, and IEC/TC 3, *Information structures, documentation and graphical symbols*. The draft was circulated for voting to the national bodies of both ISO and IEC.

The technical committees involved have agreed not to change any part of this part of ISO 10303 without mutual agreement.

This International Standard is organized as a series of parts, each published separately. The structure of this International Standard is described in ISO 10303-1.

Each part of this International Standard is a member of one of the following series: description methods, implementation methods, conformance testing methodology and framework, integrated generic resources, integrated application resources, application protocols, abstract test suites, application interpreted constructs, and application modules. This part is a member of the application protocol series.

A complete list of parts of ISO 10303 is available from the Internet:

<http://www.nist.gov/sc4/editing/step/titles/>

Annexes A to E form a normative part of this part of ISO 10303. Annexes F to J are for information only.

Introduction

ISO 10303 is an International Standard for the computer-interpretable representation and exchange of product data. The objective is to provide a neutral mechanism capable of describing product data throughout the life cycle of a product, independent from any particular system. The nature of this description makes it suitable not only for neutral file exchange, but also as a basis for implementing and sharing product databases and archiving.

This International Standard is organized as a series of parts, each published separately. The parts of ISO 10303 fall into one of the following series: description methods, integrated resources, application interpreted constructs, application protocols, abstract test suites, implementation methods, and conformance testing. The series are described in ISO 10303-1. This part of ISO 10303 is a member of the application protocol series.

EXAMPLE 1 The Figure 1 shows electrotechnical equipment in a tramcar.

EXAMPLE 2 In large installations, cables are often customized during the commissioning of an electrotechnical system.

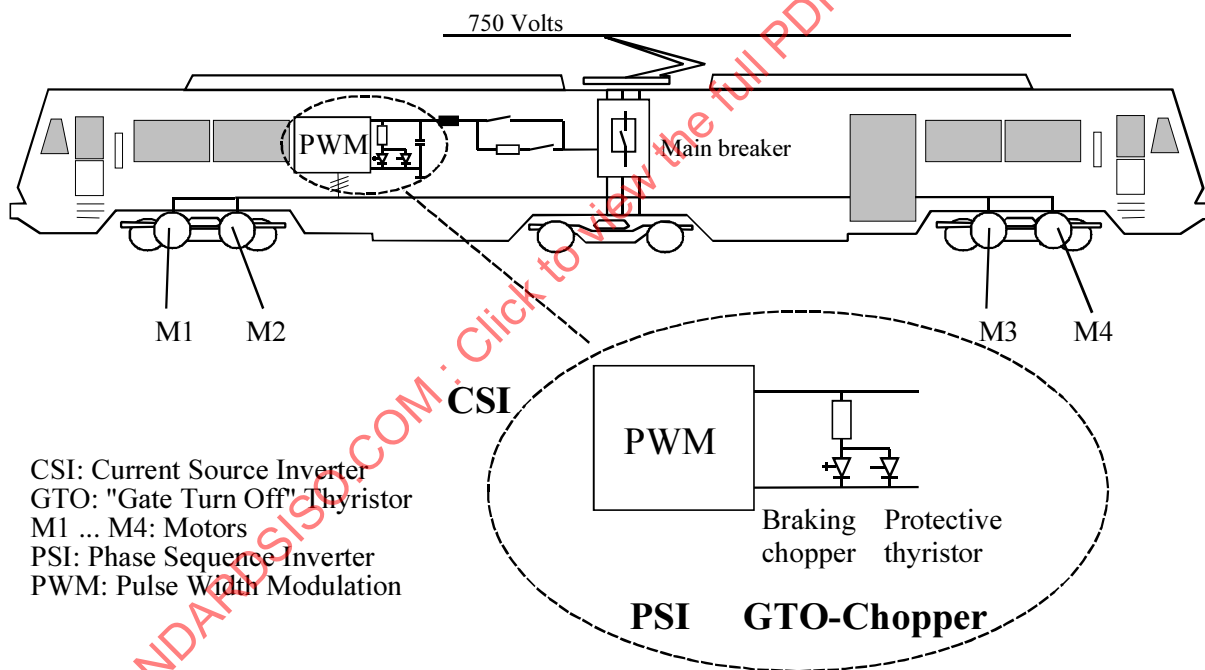

Figure 1 - Electrical equipment in a tramcar

This part of ISO 10303 specifies an application protocol (AP) for design and installation information of electrotechnical equipment used in plants, industrial systems or vehicles. This part describes the information shared between the parties involved in the design, the installation and the commissioning of the apparatus. Design is understood as a process of combining components such as relays, programmable logic controllers, or software that comprise a system. Such a system may also be used to control a chemical process in a factory. The description includes various characteristics of the

design, such as functional aspects, physical aspects or the aspects related to the installation of the equipment.

The detailed product information of procured or premanufactured parts is not included in the AP but the information needed to customize products accordingly to the requirements of the installation is included.

EXAMPLE 3 Figure 2 shows some product data that characterize an electrotechnical system. The circuitry essentially comprises the product data for main circuits and the control circuits together with the circuits for control, indication and monitoring. In Figure 2 the functions describe functional building blocks that specify the logical structure of the system, their connectivity and the signals used. The arrangement data describe how the components that make up the system are physically arranged.

Figure 3 contains the data planning model that provides a high level description of the requirements for this application protocol, as well as the relationships between the basic data components.

The planning model illustrates that an electrotechnical system is described by function-oriented product data and product-oriented product data. Both descriptions may be allocated to each other. Arrangement data, the routing of cables and the arrangement of the equipment is described by the UoFs installation, course, and site. In many cases the system components are categorized in accordance to an existing classification system. The UoF classification specifies the necessary concepts.

The information flow within the system may be described by specifying the signals that are generated, processed or transmitted within the system. The UoF messages comprises the concepts that specify the information flow.

The UoF remark allows to assign explanatory information to the system or its constituents. Organizational data such as approval or manufacturer is described by the UoF organizational_data.

Requirements and constraints levied against the system are represented by conditions that affect the products used, their functionality and their installation. Configuration_management, organizational_data, and work_management allow the handling of data concerning information about variants and options of the design, releases and approvals, or the appointment of work.

The documentation of the system is addressed by the documentation and dimensioned_documentation data. Designation data allows the identification of the equipment or its functions uniquely within the system. Technical data may be addressed by assigning property data to the elements of the data model.

This application protocol defines the context, scope, and information requirements for the exchange of design and installation information of electrotechnical equipment and specifies the integrated resources necessary to satisfy these requirements.

Application protocols provide the basis for developing implementations of ISO 10303 and abstract test suites for the conformance testing of AP implementations.

Clause 1 defines the scope of the application protocol and summarizes the functionality and data covered by the AP. Clause 3 lists the words defined in this part of ISO 10303 and gives pointers to words defined elsewhere. An application activity model that is the basis for the definition of the scope is provided in annex F. The information requirements of the application are specified in clause

4 using terminology appropriate to the application. A graphical representation of the information requirements, referred to as the application reference model, is given in annex G.

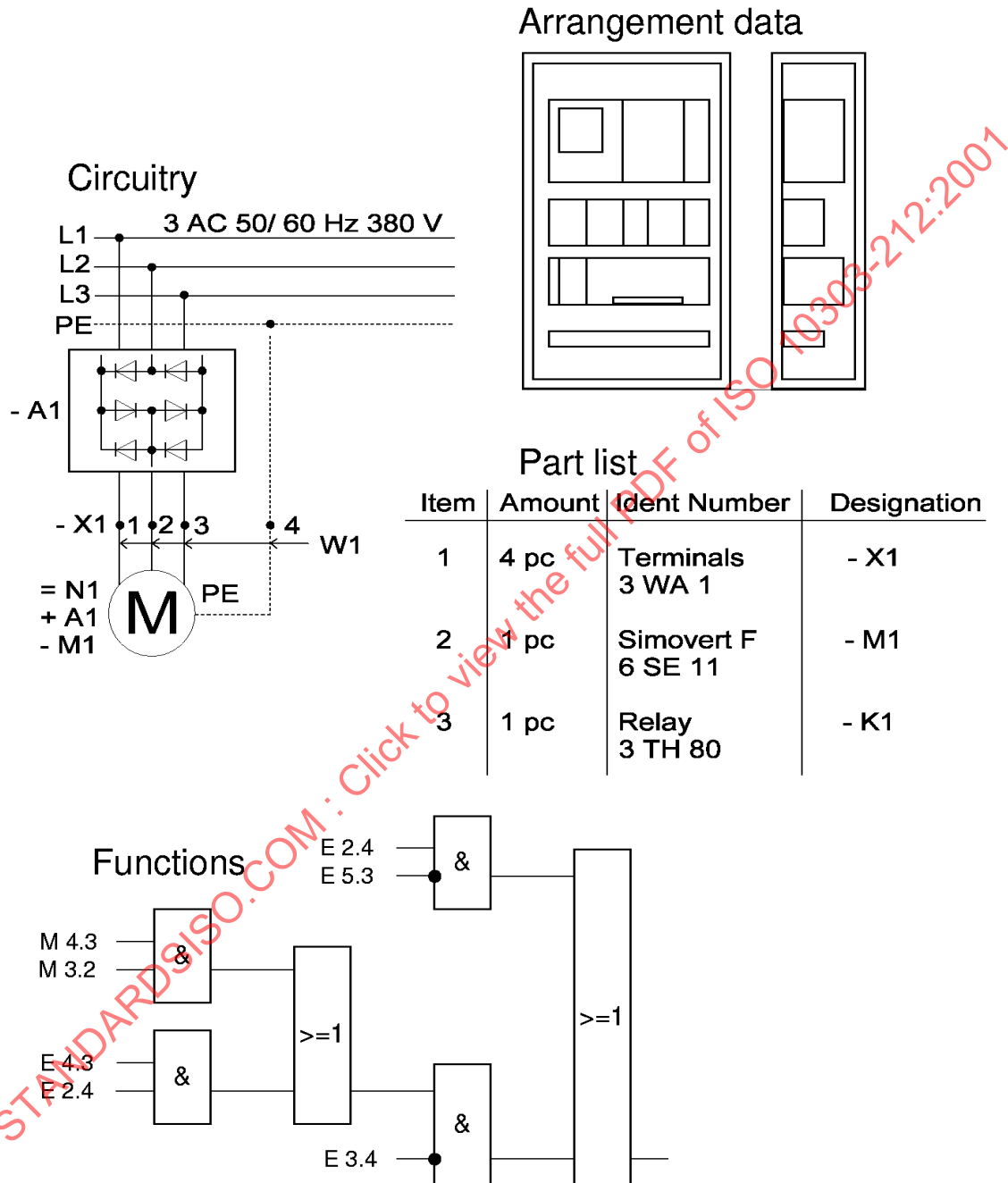

Figure 2 - Product data that characterizes industrial electrotechnical equipment

Resource constructs are interpreted to meet the information requirements. This interpretation produces the application interpreted model (AIM). This interpretation, given in 5.1, shows the correspondence between the information requirements and the AIM. The short listing of the AIM specifies the interface to the integrated resources and is given in 5.2. Note that the definitions and EXPRESS provided in the integrated resources for constructs used in the AIM may include select list items and subtypes which are not imported into the AIM. The expanded listing given in Annex A contains the complete EXPRESS for the AIM without annotation. A graphical representation of the AIM is given in annex H. Additional requirements for specific implementation methods are given in annex C.

STANDARDSISO.COM : Click to view the full PDF of ISO 10303-212:2001

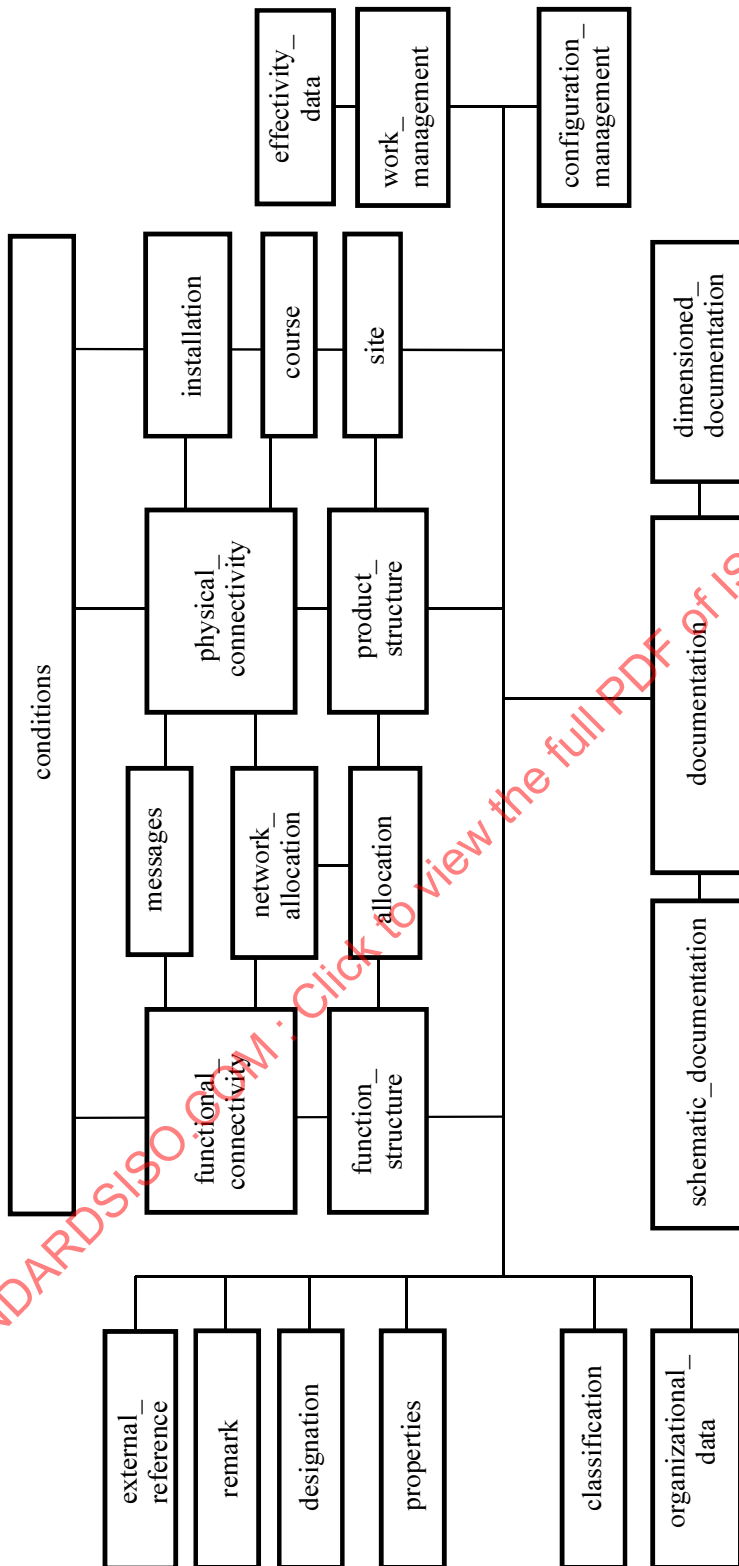

Figure 3 - Data planning model

Industrial automation systems and integration — Product data representation and exchange — Part 212: Application protocol: Electrotechnical design and installation

1 Scope

This part of ISO 10303 specifies the use of the integrated resources necessary for the scope and information requirements for the design, installation, and commissioning of electrotechnical systems. This Application protocol does not impose any restriction on the usage of these systems. Equipment for power-transmission, -distribution, and -generation, electrical machinery, electric light, electric heat, control and automation systems is in scope.

EXAMPLE 1 Electrotechnical systems may be used in plants, buildings, or transportation systems such as cars or ships, etc.

The information content of documents that describe a system in accordance to IEC 61082: *Preparation of documents used in electrotechnology* is part of the scope. Also included is the decomposition of products and functions, their interrelations, their connectivity and their schematic representation.

NOTE 1 The application activity model in annex F provides a graphical representation of the processes and information flows that are the basis for the definition of the scope of this part of ISO 10303.

The following are within the scope of this part of ISO 10303.

— Data to describe an electrotechnical system throughout design, commissioning and delivery phases;

NOTE 2 Throughout the commissioning of a system an operating time of significant duration may occur. Such a stage is often requested by the customer to verify the operating performance of the system. The data required to keep track of design changes or maintenance activities are considered to be part of the data that describe commissioning of the system.

— Data to specify the equipment used in the electrotechnical system;

— Data to describe terminals and interfaces of the equipment;

— Data to describe the functional decomposition of the system;

— Data to describe the connectivity and cabling of devices and equipment;

ISO 10303-212:2001(E)

- Data to specify the installation of the equipment, including physical locations and information about the shape of the equipment;
- Data for the reference designation of the design's functional modules and of the equipment used;
- Data to specify the pieces of information exchanged between the various constituents of the design;
- Data to provide the design with actual and planned technical characteristics;
- Data to document the system or its design and to keep track of version and status of the documentation;
- Data for the tracking of a design's release;
- Data to track the approval of functional and physical objects used in the system;
- Data to perform the configuration management of the equipment;
- Data to describe the requirements levied upon the design and their allocation to functional objects, physical objects, and the physical implementation;
- Data to provide information about the contractual basis and the work packages assigned to develop and implement the design;
- Data to classify and categorize the functional and physical objects that make up the electrotechnical system in accordance to standardized or user specific classification systems;
- Data to the assignment of comments or instructions to the product data;

The following are outside the scope of this part of ISO 10303.

- Detailed product information or manufacturing information of procured premanufactured parts;
 - Data for the simulation and testing of electrotechnical systems;
- EXAMPLE 2 Information about test patterns, behavioural models, etc.
- Detailed mechanical design information of electric/electronic products;
 - The management of the process used for the design of electrotechnical systems;
 - The process plans for the procurement, assembly or shipping of electrotechnical systems or their constituents;
 - The administrative procurement and cost data used by an enterprise.

2 Normative references

The following normative documents contain provisions which, through reference in this text, constitute provisions of this part of ISO 10303. For dated references, subsequent amendments to, or revisions of, any of these publications do not apply. However, parties to agreements based on this part of ISO 10303 are encouraged to investigate the possibility of applying the most recent editions of the normative documents indicated below. For undated references, the latest edition of the normative document referred to applies. Members of ISO and IEC maintain registers of currently valid International Standards.

IEC 61082-1:1991, *Preparation of documents used in electrotechnology — Part 1: General requirements.*

IEC 61360:1995, *Standard data element types with associated classification scheme for electric components.*

ISO 639:1988, *Code for the representation of names of languages.*

ISO/IEC 646:1991, *Information technology — ISO 7-bit coded character set for information interchange.*

ISO/IEC 6937:1994, *Information technology — Coded character set for text communication — Latin alphabet.*

ISO/IEC 8824-1:1998, *Information technology — Abstract Syntax Notation One (ASN.1): Specification of basic notation.*

ISO/IEC 8859-1:1998, *Information technology — 8-bit single-byte coded graphic character sets — Part 1: Latin alphabet No. 1.*

ISO/IEC 10646, *Information technology — Universal Multiple-Octet Coded Character Set (UCS).*

ISO 10303-1:1994, *Industrial automation systems and integration — Product data representation and exchange — Part 1: Overview and fundamental principles.*

ISO 10303-11:1994, *Industrial automation systems and integration — Product data representation and exchange — Part 11: Description methods: The EXPRESS language reference manual.*

ISO 10303-21:1994, *Industrial automation systems and integration — Product data representation and exchange — Part 21: Implementation methods: Clear text encoding of the exchange structure.*

ISO 10303-31:1994, *Industrial automation systems and integration — Product data representation and exchange — Part 31: Conformance testing methodology and framework: General concepts.*

ISO 10303-212:2001(E)

ISO 10303-32:1998, *Industrial automation systems and integration — Product data representation and exchange — Part 32: Conformance testing methodology and framework: Requirements on testing laboratories and clients.*

ISO 10303-41:2000, *Industrial automation systems and integration — Product data representation and exchange — Part 41: Integrated generic resource: Fundamentals of product description and support.*

ISO 10303-42:1994, *Industrial automation systems and integration — Product data representation and exchange — Part 42: Integrated generic resources: Geometric and topological representation.*

ISO 10303-43:2000, *Industrial automation systems and integration — Product data representation and exchange — Part 43: Integrated generic resource: Representation structures.*

ISO 10303-44:2000, *Industrial automation systems and integration — Product data representation and exchange — Part 44: Integrated generic resource: Product structure configuration.*

ISO 10303-45:1998, *Industrial automation systems and integration — Product data representation and exchange — Part 45: Integrated generic resource: Materials.*

ISO 10303-46:1994, *Industrial automation systems and integration — Product data representation and exchange — Part 46: Integrated generic resources: Visual presentation.*

ISO 10303-49:1998, *Industrial automation systems and integration — Product data representation and exchange — Part 49: Integrated generic resources: Process structure and properties.*

ISO 10303-504:2000, *Industrial automation systems and integration — Product data representation and exchange — Part 504: Application interpreted construct: Draughting annotation.*

ISO 10303-506:2000, *Industrial automation systems and integration — Product data representation and exchange — Part 506: Application interpreted construct: Draughting elements.*

3 Terms, definitions, and abbreviations

For the purposes of this International Standard, the following definitions apply.

3.1 Terms defined in IEC 61082-1

For the purposes of this part of ISO 10303, the following terms defined in IEC 61082-1 apply.

- attached representation;
- block diagram;
- circuit diagram;
- connection diagram;
- detached representation;
- diagram;
- document;
- function diagram;
- overview diagram.

3.2 Terms defined in ISO 10303-1

For the purposes of this part of ISO 10303, the following terms defined in ISO 10303-1 apply.

- application;
- application activity model (AAM);
- application interpreted model (AIM);
- application object;
- application protocol (AP);
- application reference model (ARM);
- conformance testing;
- implementation method;
- integrated resource;
- model;
- PICS proforma;
- product;

ISO 10303-212:2001(E)

- product data;
- unit of functionality (UoF).

3.3 Terms defined in ISO 10303-31

For the purposes of this part of ISO 10303, the following terms defined in ISO 10303-31 apply.

- conformance class.

3.4 Terms defined in ISO 10303-42

For the purposes of this part of ISO 10303, the following terms defined in ISO 10303-42 apply.

- b spline curve;
- composite curve;
- conic;
- coordinate space;
- curve;
- line;
- polyline;
- trimmed curve.

3.5 Terms defined in ISO 10303-44

For the purposes of this part of ISO 10303, the following terms defined in ISO 10303-44 apply.

- constituent.

3.6 Terms defined in ISO 10303-46

For the purposes of this part of ISO 10303, the following terms defined in ISO 10303-46 apply.

- layer;
- presentation;
- visualization.

3.7 Other terms and definitions

For the purposes of this part of ISO 10303, the following terms and definitions apply.

3.7.1

circuit

an arrangement of networks, devices, or media that allows the flow or association of information, energy, or material within a physical or non-physical product

3.7.2

coded character set

a set of unambiguous rules that establishes a character set and the one-to-one relationship between each character of the set and its coded representation

3.7.3

component

an occurrence of a product used in an assembled product

NOTE A component may be a piece of equipment or a functional module.

3.7.4

connectivity

the entire arrangement of conductors or networks for joining ports, terminals or other conductors

3.7.5

electrotechnical equipment

the apparatus that supports the distribution, generation, storage, transformation, or utilization of electrical energy

3.7.6

electrotechnical system

a system performing its objectives by using mainly electrotechnical equipment

3.7.7

function block

a base element into which the functionality of an electrotechnical system may be decomposed

NOTE A function block may be decomposed into other function blocks.

3.7.8

functionality

the intended purpose or use of a piece of equipment

3.7.9

human-interpretable string

a sequence of alphanumeric characters intended to be interpreted by humans only, even though the information may be stored or displayed by a computer

3.7.10

GIS position

a position specified through a global information system

STANDARDSISO.COM : Click to view the full PDF of ISO 10303-212:2001

3.7.11**industrial system**

a system designed or suitable for industrial use

EXAMPLE Systems designed to be used in a production environment with a high resistance against shock or magnetic fields.

3.7.12**interface**

a complex access mechanism to the functionality of a component

NOTE In most cases an interface comprises a combination of one or more ports.

3.7.13**occurrence**

the use of a typical item at a specific place in a design. Each occurrence is a separate item that refers to the typical item

EXAMPLE Potentiometers is a data class containing catalog items. One instance of the class of potentiometers specifies a potentiometer of type P104 with a resistance of 400 Ohm. The data class of occurrences contains two instances specifying potentiometers R1 and R2 of type P104 that are currently in use. R1 is set to a potential divider ratio of 75% and R2 is set to a potential divider ratio of 10%. Both have the resistance of 400 Ohm because both are occurrences of P104.

3.7.14**port**

an access point to a functionality

NOTE Even though, in most cases, a port is implemented by the use of one or more terminals, it is not required for a port to have a physical equivalent.

3.7.15**system**

a set of interdependent elements constituted to achieve a given objective by performing a specified function. This includes the equipment used, as well as non-physical items like software, that ensures proper control and interaction of the equipment

3.7.16

terminal

an access point to a piece of equipment

3.8 Abbreviations

For the purpose of this part of ISO 10303, the following abbreviations apply.

- AAM application activity model;
- AIM application interpreted model;
- AP application protocol;
- ARM application reference model;
- ASCII American Standard Code for Information Interchange
- CAD computer aided design;
- GIS geographic information system;
- id identifier;
- RGB a colorimetric system identifying colours by specifying their red, green and blue portions;
- UoF unit of functionality.

4 Information requirements

This subclause specifies the information required for the design, installation, and commissioning of electrotechnical systems.

The information requirements are specified as a set of units of functionality, application objects, and application assertions. These assertions pertain to individual application objects and to relationships between application objects. The information requirements are defined using the terminology of the subject area of this application protocol.

NOTE 1 A graphical representation of the information requirements is given in annex G.

NOTE 2 The information requirements correspond to those of the activities identified as being within the scope of this application protocol in annex F.

NOTE 3 The mapping table specified in 5.1 shows how the integrated resources and application interpreted constructs are used to meet the information requirements of this application protocol.

4.1 Units of functionality

This subclause specifies the units of functionality (UoF) for the Electrotechnical design and installation application protocol. This part of ISO 10303 specifies the following units of functionality:

- allocation (AL1);
- classification (CA1);
- conditions (CD1);
- configuration_management (CF1);
- course (CO1);
- designation (DE1);
- dimensioned_documentation (DI1);
- documentation (DO1);
- effectivity_data (EF1);
- external_reference (ER1);
- function_structure (F1);
- functional_connectivity (C1);
- installation (IN1);
- messages (M1);

ISO 10303-212:2001(E)

- network_allocation (NA1);
- organizational_data (OD1);
- physical_connectivity (PC1);
- product_structure (PD1);
- properties (PR1);
- remark (R1);
- schematic_documentation (SC1);
- site (SI1);
- work_management (W1).

The units of functionality and a description of the functions that each UoF supports are given below. The application objects included in the UoFs are defined in 4.2.

4.1.1 allocation (AL1)

The allocation UoF defines information that supports assignment of the elements designated in both the function_structure UoF and the product_structure UoF. The allocation UoF provides the relationship between the description of the equipment and the appropriate functional description of that equipment.

NOTE Allocation of connectivity is not in the scope of this UoF.

The following application objects are used by the allocation UoF:

- Functional_unit_allocation;
- Offered_function_allocation;
- Preferred_item_allocation.

4.1.2 classification (CA1)

The classification UoF specifies all concepts to categorize the packages of information contained in the product data. This includes the information about the documents that specify the classification method.

The following application objects are used by the classification UoF:

- Class_reference;
- Classification_association;
- Classification_attribute;
- Classification_system;

- General_classification;
- General_classification_hierarchy.

4.1.3 conditions (CD1)

The conditions UoF describes the information that is specified in requirements levied against the design or its implementation.

NOTE Requirements laid down in textual form, as property values, or as interface requirements are included.

The following application objects are used by the conditions UoF:

- Requirement;
- Requirement_assignment;
- Requirement_document_assignment;
- Requirement_relationship.

4.1.4 configuration_management (CF1)

The configuration_management UoF specifies the concepts for the specification of the planned use of equipment and on the configurations the equipment may be used in. Specification (see 4.2.323) of variants are included in the scope of the configuration_management UoF.

The following application objects are used by the configuration_management UoF:

- Alternative_solution;
- Class_category_association;
- Class_condition_association;
- Class_inclusion_association;
- Class_specification_association;
- Class_structure_relationship;
- Complex_product;
- Complex_product_relationship;
- Component_placement;
- Configuration;
- Descriptive_specification;
- Device_relationship;

ISO 10303-212:2001(E)

- Final_solution;
- Instance_placement;
- Product_class;
- Product_class_relationship;
- Product_component;
- Product_identification;
- Product_specification;
- Product_structure_relationship;
- Solution_instance_assignment;
- Specification;
- Specification_category;
- Specification_category_hierarchy;
- Specification_expression;
- Specification_inclusion;
- Supplier_solution;
- Technical_solution.

4.1.5 course (CO1)

The course UoF specifies the data used to describe a three-dimensional path to specify the path of pieces of equipment.

EXAMPLE Examples for pieces of equipment with an assigned path are cable ducts or wireways.

The following application objects are used by the course UoF:

- Curve_3d;
- Node;
- Node_relationship;
- Path;
- Path_node;
- Path_node_relationship;

- Path_relationship;
- Path_segment.

4.1.6 designation (DE1)

The designation UoF describes concepts used to identify equipment items and function blocks. An item designator may be composed from other designators. The concepts to describe this structure and methods to categorize the constituents of an item designation are in the scope of this UoF. Identification of documents, signals or locations is also addressed by the designation UoF.

The following application objects are used by the designation UoF:

- Document_designation;
- Object_designation;
- Object_designation_relationship;
- Object_reference_designation;
- Signal_designation;
- Terminal_designation.

4.1.7 dimensioned_documentation (DH)

The dimensioned_documentation UoF specifies concepts to present the electrotechnical system or parts thereof in pictorial or textual form. Dimensioned drawings or schematic diagrams may be used for that purpose.

EXAMPLE Examples for drawings addressed by dimensioned_documentation UoF are installation diagrams, ground plans, etc.

The following application objects are used by the dimensioned_documentation UoF:

- Angular_dimension;
- Chained_dimension_pair;
- Curve_dimension;
- Datum_feature_callout;
- Datum_target_callout;
- Diameter_dimension;
- Dimension;
- Dimension_callout;
- Dimension_line;

ISO 10303-212:2001(E)

- Dimension_line_terminator;
- Dimension_sequence_pair;
- Dimension_symbol;
- Directed_curve;
- Draughting_callout;
- Geometrical_tolerance;
- Geometrical_tolerance_symbol;
- Leader;
- Leader_directed_dimension;
- Leader_terminator;
- Linear_dimension;
- Ordinate_dimension;
- Parallel_dimension_pair;
- Point_marker_symbol;
- Predefined_symbol;
- Projection_line;
- Radius_dimension;
- Structured_dimension_callout;
- Terminator_symbol;
- Unstructured_dimension_callout.

4.1.8 documentation (DO1)

The documentation UoF specifies concepts to present the electrotechnical system or parts thereof in pictorial or textual form using two-dimensional drawings.

NOTE The concepts used to visualize dimensioned drawings are not included in this UoF.

EXAMPLE Examples for drawings addressed by documentation UoF are circuit diagrams, connection lists, terminal diagrams, etc.

The following application objects are used by the documentation UoF:

- Annotation_curve;

- Annotation_element;
- Annotation_placed_annotation;
- Annotation_subfigure;
- Annotation_subfigure_definition;
- Annotation_subfigure_definition_element;
- Annotation_symbol;
- Appearance;
- Cartesian_coordinate_space_2d;
- Colour;
- Curve_2d;
- Curve_appearance;
- Draughting_annotation;
- Draughting_model;
- Drawing;
- Drawing_assignment;
- Drawing_sequence;
- Drawing_sheet;
- Drawing_sheet_layout;
- Drawing_sheet_relationship;
- Drawing_view;
- Externally_defined_hatching;
- Externally_defined_line_font;
- Externally_defined_symbol;
- Externally_defined_text_font;
- Externally_defined_tile;
- Externally_defined_tiling;
- Fill_area;

ISO 10303-212:2001(E)

- Fill_area_appearance;
- Fill_area_boundary;
- Group;
- Group_annotation_element;
- Group_element;
- Hatching_pattern;
- Layer;
- Line_font;
- Model_placed_annotation;
- Point_2d;
- Predefined_colour;
- Predefined_line_font;
- Predefined_text_font;
- Rectangular_area;
- Sheet_placed_annotation;
- Solid_fill_area;
- Sub_group;
- Text;
- Text_appearance;
- Text_font;
- Text_string;
- Tile;
- User_defined_colour;
- User_defined_hatching;
- User_defined_line_font;
- User_defined_symbol;
- User_defined_symbol_definition;

- User_defined_tile;
- User_defined_tiling;
- View_displayed_model;
- View_placed_annotation;
- Visibility.

4.1.9 effectivity_data (EF1)

The effectivity_data UoF provides the capability to represent information concerning the validity of data. The validity of data can be expressed by effectivities that specify time ranges within which data may be used. Retention periods specify how long data have to be kept and when they may be deleted. Both concepts can use explicit dates or dates expressed by events to represent the relevant points in time.

The following application objects are used by the effectivity_data UoF:

- Dated_configuration;
- Duration;
- Effectivity;
- Effectivity_assignment;
- Effectivity_relationship;
- Event_reference;
- Lot_configuration;
- Manufacturing_configuration;
- Product_class;
- Product_identification;
- Product_design;
- Retention_period;
- Serial_configuration.

4.1.10 external_reference (ER1)

The external_reference UoF specifies a reference mechanism to assign additional information to the product data. This information may be available in either electronic or nonelectronic form.

ISO 10303-212:2001(E)

NOTE Content or format of the referenced data need not be in accordance with this part nor with any other part of ISO 10303.

EXAMPLE Simulation data can be assigned to the product data by using the external_reference UoF.

The following application objects are used by the external_reference UoF:

- Coded_size;
- Digital_document;
- Digital_file;
- Document;
- Document_assignment;
- Document_content_property;
- Document_creation_property;
- Document_file;
- Document_file_relationship;
- Document_format_property;
- Document_location_property;
- Document_size_property;
- Document_type_property;
- Document_representation;
- Document_structure;
- Document_version;
- Document_version_relationship;
- External_file_id_and_location;
- Hardcopy;
- Language;
- Physical_document;
- Rectangular_size;
- Specific_document_classification.

4.1.11 function_structure (F1)

The function_structure UoF specifies the concepts for the description of the functional decomposition of an electrotechnical system. The data describes a segment of an electrotechnical system independent of the specific product used in that segment. The functionality that the segment is to perform is identified. The functions may be either primitive, i.e., its internal structure is not further described, or it may be composed from other functions.

NOTE The concepts for the specification of the connectivity among the function blocks are not part of the function_structure UoF.

The following application objects are used by the function_structure UoF:

- Composition_relationship;
- Function_definition;
- Function_definition_relationship;
- Function_unit;
- Function_unit_relationship;
- Function_version;
- Function_version_relationship;
- Functionality;
- Single_function_unit;
- Specified_function_unit.

4.1.12 functional_connectivity (FC1)

The functional_connectivity UoF specifies all those concepts that are required to specify the connectivity among the function blocks describing an electrotechnical system. The specification of the interface through which a function block can be interconnected with other function blocks and the concepts to specify the connectivity among them are included.

EXAMPLE Figure 4 shows the functionality of a gas-insulated switchgear. The functionality is described by the function_structure UoF and functional_connectivity UoF. The product data that describes the switchgear comprises concepts from product_structure UoF and physical_connectivity UoF.

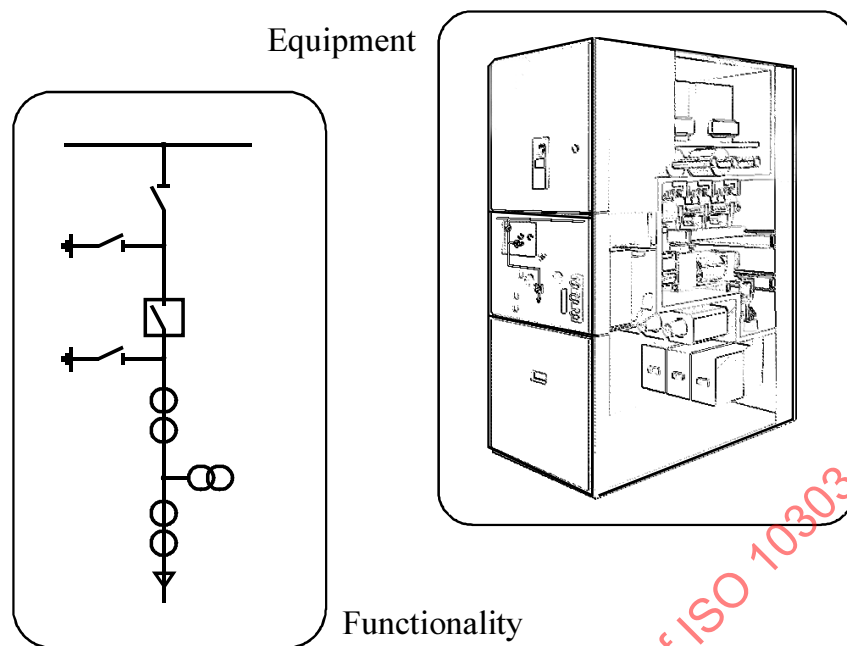

Figure 4 - Functionality of a gas - insulated switchgear

The following application objects are used by the functional_connectivity UoF:

- Function_interface;
- Functional_connectivity_definition;
- Functional_connectivity_definition_relationship;
- Interface_port;
- Interface_port_relationship;
- Interface_port_connectivity;
- Network;
- Port;
- Port_association;
- Port_relationship;

4.1.13 installation (IN1)

The installation UoF describes the arrangement of the items that make up the electrotechnical system. The data needed for cable routing and cable pulling is in the scope of the installation UoF. Concepts that specify routes are also in the scope of the installation UoF.

EXAMPLE Figure 5 shows sectional views of an electrical installation using cabletrays and control cabinets. The arrangement of the equipment and the laying of the cables is described by using concepts from installation UoF, course UoF, and site UoF.

NOTE The content of the text shown in Figure 5 is for presentation purposes only. Its meaning is not essential for this part of 10303.

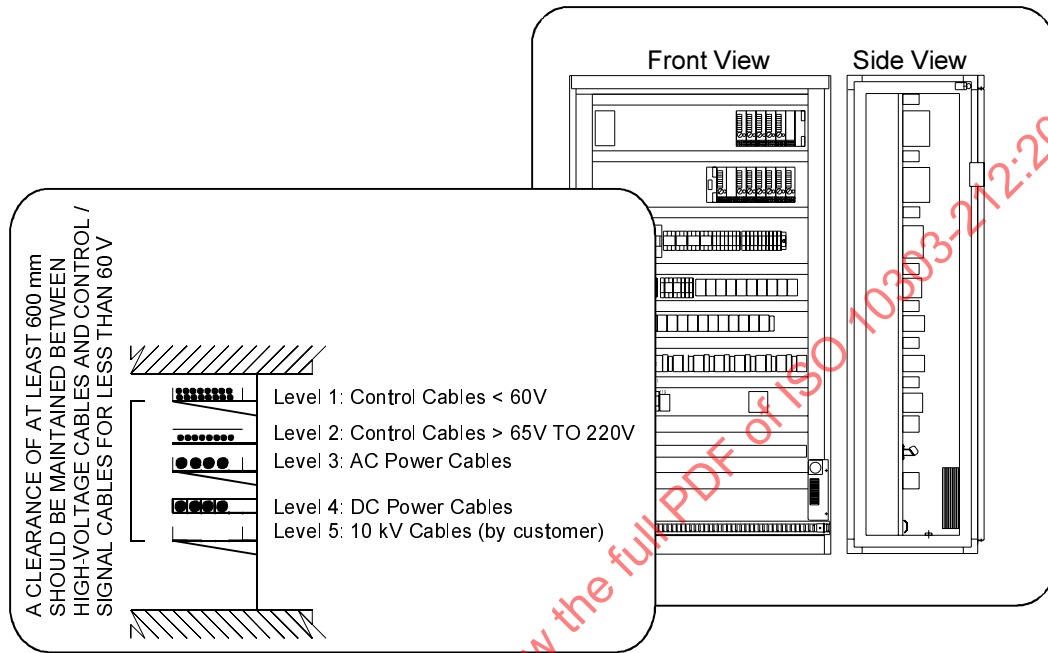

Figure 5 - Example of an installation; installation of devices on cabletrays or in cabinets

The following application objects are used by the installation UoF:

- Cable_pull_information;
- General_location_relationship;
- Free_segment;
- Route;
- Route_relationship;
- Routed_object;
- Routed_segment;
- Section;
- Section_end;

ISO 10303-212:2001(E)

- Section_interface;
- Section_interface_relationship;
- Section_relationship.

4.1.14 messages (M1)

The messages UoF specifies the concepts used to describe the flow of information within an electrotechnical system. The concepts to specify the physical representation of the information within the system and the concepts that specify the information content are included. The physical parameters that cause the information flow can be also described.

The following application objects are used by the messages UoF:

- Notification;
- Notification_relationship;
- Preferred_equipment_assignment;
- Process_variable;
- Process_variable_relationship;
- Process_variable_system_assignment;
- Signal;
- Signal_relationship;
- Signal_system_assignment;
- Signal_value.

4.1.15 network_allocation (NA1)

The network_allocation UoF defines information that supports the allocation of functional connectivity information to the connectivity established by the equipment used in the electrotechnical system. This includes the data to relate the functional connect nodes to their physical counterparts.

The following application objects are used by the network_allocation UoF:

- Connectivity_allocation;
- Port_allocation;
- Preferred_item_terminal_allocation.

4.1.16 organizational_data (OD1)

The organizational_data UoF specifies the concepts to assign organizational information to the product data. This information provides the basis for the management of the product data.

EXAMPLE Examples for organizational information are approval information, information about ownership, time stamps, etc.

The following application objects are used by the organizational_data UoF:

- Address;
- Approval;
- Approval_relationship;
- Approval_status;
- Certification;
- Date_and_person_assignment;
- Date_and_person_or_organization;
- Date_time;
- Date_time_assignment;
- Date_time_interval_assignment;
- Duration;
- Organization;
- Organization_relationship;
- Person;
- Person_in_organization;
- Person_in_organization_relationship;
- Person_organization_assignment;
- Security_classification;
- Security_level;
- Time_interval.

4.1.17 physical_connectivity (PC1)

The physical_connectivity UoF specifies the concepts required to specify the connectivity among the equipment within an electrotechnical system. The specification of the interface through which a piece

ISO 10303-212:2001(E)

of equipment may be interconnected with other devices and the concepts to specify the connectivity among the equipment are included.

EXAMPLE Figure 6 shows a wiring harness of a vehicle. To describe its assembly structure and connectivity concepts of product_structure UoF and physical_connectivity UoF are used.

NOTE The content of the text shown in Figure 6 is for presentation purposes only. Its meaning is not essential for this part of 10303.

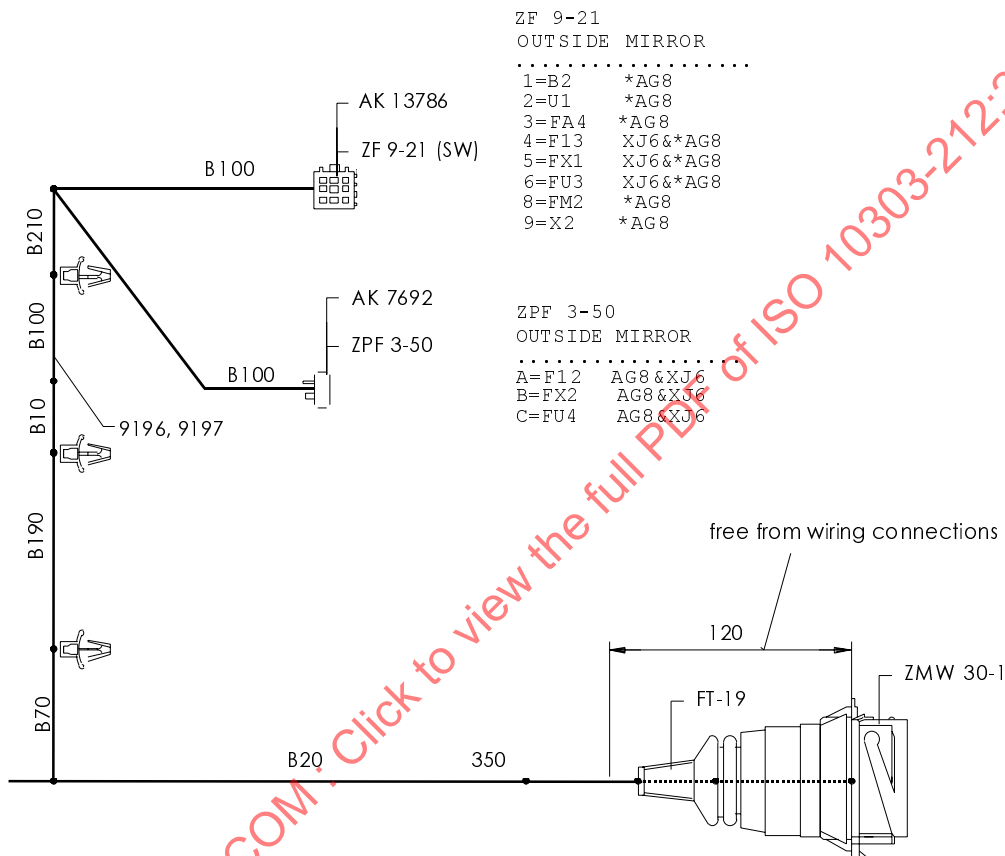

Figure 6 - Example of a product description: output of a wiring harness

The following application objects are used by the physical_connectivity UoF:

- Connection;
- Connectivity_definition;
- Connectivity_definition_relationship;
- Interface;
- Interface_terminal;
- Interface_terminal_relationship;
- Interface_terminal_connection;

- Predefined_connection;
- Terminal;
- Terminal_relationship.

4.1.18 product_structure (PD1)

The product_structure UoF specifies the concepts for the description of the hierarchical structure of the equipment used within an electrotechnical system.

NOTE The concepts for the specification of connectivity among products are not part of the product_structure UoF.

The following application objects are used by the product_structure UoF:

- Alias_designation;
- Alias_identification;
- Alias_version;
- Alternate_item_relationship;
- Application_context;
- Assembly_component_relationship;
- Assembly_substitute_relationship;
- Assembly_definition;
- Component_placement;
- Design_discipline_item_definition;
- Device;
- Item;
- Item_definition_relationship;
- Item_identification;
- Item_version;
- Item_version_relationship;
- Make_from_relationship;
- Next_higher_assembly;
- Numerical_precision;

ISO 10303-212:2001(E)

- Part;
- Physical_assembly_relationship;
- Physical_instance;
- Product_constituent;
- Promissory_usage;
- Quantified_device;
- Selected_device;
- Shape;
- Shape_assignment;
- Single_device;
- Specific_classification_hierarchy;
- Specific_item_classification;
- Specific_item_classification_hierarchy;
- Specified_device;
- Technical_system;
- Technical_system_relationship.

4.1.19 properties (PR1)

The properties UoF specifies a generic concept to assign technical or management data to the information packages that make up the product data.

The following application objects are used by the properties UoF:

- Aggregated_value;
- Binary_value;
- Body_breadth;
- Body_height;
- Body_length;
- Component_colour;
- Cross_section;

- Data_element;
- Data_element_association;
- Data_element_definition;
- Data_element_definition_relationship;
- Data_element_relationship;
- Data_element_specification;
- Data_element_value;
- External_library_reference;
- Format_of_value;
- Logical_value;
- Mass;
- Material;
- Mounting_features;
- Numerical_value;
- Operating_temperature;
- Outside_diameter;
- Predefined_data_element;
- Property_reference;
- Rated_current;
- Rated_power;
- Rated_voltage;
- Single_value;
- Storage_temperature;
- String_value;
- User_defined_data_element.

ISO 10303-212:2001(E)

4.1.20 remark (R1)

The remark UoF specifies the concepts to associate additional human-interpretable information to the product data. Markings applied to the equipment are also supported by the remark UoF.

EXAMPLE Examples for the information supported by remark UoF include information such as comments, assembly instructions, manufacturing instructions, etc.

The following application objects are used by the remark UoF:

- Generic_note;
- Linear_pattern_location;
- Marking;
- Multi_language_note;
- Note;
- Note_association;
- Set_of_notes.

4.1.21 schematic_documentation (SC1)

The schematic_documentation UoF specifies the concepts used to present product data in schematic diagrams.

NOTE The concepts used to visualize dimensioned drawings are not included in this UoF.

EXAMPLE Examples for schematic constructs are symbols, schematic connections, or cross references.

The following application objects are used by the schematic_documentation UoF:

- Cartesian_coordinate_space_with_grid;
- Connect_area;
- Connecting_line;
- Cross_reference;
- Detached_representation_reference;
- Direction_range;
- Item_presentation;
- Note_reference;
- Page_connector;

- Page_connector_presentation;
- Page_connector_reference;
- Reference_grid;
- Reference_grid_layout;
- Schematic_node;
- Schematic_text;
- Typical_schematic_node;
- Typical_schematic_text.

4.1.22 site (SI1)

The site UoF describes the location where the equipment is positioned. Location (see 4.2.192) is understood as a defined volume of space that contains equipment. Hierarchical decomposition of locations or neighbourhood relationships between locations are supported. Global positioning system data may be applied to specify the three-dimensional position.

The following application objects are used by the site UoF:

- Cartesian_point;
- Cartesian_coordinate_space_3d;
- General_location_relationship;
- Gis_position;
- Hierarchical_location_relationship;
- Location;
- Location_assignment;
- Location_relationship;
- Neighbourhood_location_relationship.

4.1.23 work_management (W1)

The work_management UoF specifies the concepts for activity specific, project specific, and contract specific information. This UoF also supports concepts to keep track of changes that result from various activities throughout the lifecycle of an electrotechnical system.

The following application objects are used by the work_management UoF:

- Activity;

ISO 10303-212:2001(E)

- Activity_element;
- Activity_method;
- Activity_method_assignment;
- Activity_relationship;
- Contract;
- Organization_in_contract;
- Project;
- Project_relationship;
- Work_order;
- Work_request.

4.2 Application objects

This subclause specifies the application objects for the Electrotechnical design and installation application protocol. Each application object is an atomic element that embodies a unique application concept and contains attributes specifying the data elements of the object. The application objects and their definitions are given below.

4.2.1 Activity

An Activity is the fact of achieving or accomplishing an action.

The data associated with an Activity are the following:

- activity_type;
- actual_end_date;
- actual_start_date;
- chosen_method;
- concerned_organization;
- description;
- id;
- internal;
- planned_end_date;
- planned_start_date;
- requestor;
- resolved_request;
- status;
- supplying_organization.

4.2.1.1 activity_type

The activity_type specifies the kind of the Activity. The value is either user defined or predefined.

ISO 10303-212:2001(E)

The predefined value of activity_type is one of the following:

- amendment;
- analysis;
- cancellation;
- delivery change;
- design change;
- design;
- mock-up creation;
- order;
- prototype building;
- rectification;
- restructuring;
- spare part creation;
- stop notice;
- testing;
- work definition.

NOTE See 4.2.1.1.1 - 4.2.1.1.14 for the definition of each predefined value for activity_type.

4.2.1.1.1 amendment

amendment: An activity to add information to product data.

4.2.1.1.2 analysis

analysis: An activity to determine the behaviour of an item version under certain physical circumstances.

4.2.1.1.3 cancellation

cancellation: An activity to delete an item from the bill of material or to cancel the whole bill of material.

4.2.1.1.4 delivery change

delivery change: An activity to change an element delivery.

4.2.1.1.5 design change

design change: An activity to change the design or data such as geometry, master data, or properties of an item or an assembly.

4.2.1.1.6 design

design: An activity concerning the development of the design of an item or a product.

4.2.1.1.7 mock-up creation

mock-up creation: An activity to create an experimental model or replica of an item.

4.2.1.1.8 order

order: An activity to issue written direction to a manufacturer, tradesman, etc., to supply something.

4.2.1.1.9 prototype creation

prototype creation: An activity to manufacture the preliminary version of an item or product.

4.2.1.1.10 rectification

rectification: An activity to correct the data, documentation, or structure belonging to an item.

4.2.1.1.11 restructuring

restructuring: An activity to create a new structure or position within a bill of material without changing the data of the items.

4.2.1.1.12 spare part creation

spare part creation: An activity to design a spare part or to classify an item as a spare part.

4.2.1.1.13 stop notice

stop notice: An activity to stop the manufacturing process of an item.

4.2.1.1.14 testing

testing: An activity to test an item or a product.

4.2.1.1.15 work definition

work definition: An Activity to manage several sub-activities related to this Activity by an Activity_ - relationship (see 4.2.5) with a 'relation_type' of value 'decomposition'..

4.2.1.2 actual_end_date

The actual_end_date specifies the date when the Activity was actually finished.

The actual_end_date need not be specified for a particular Activity.

ISO 10303-212:2001(E)

See 4.3.3 for the application assertion.

4.2.1.3 actual_start_date

The actual_start_date specifies the date when the Activity was actually started.

The actual_start_date need not be specified for a particular Activity.

See 4.3.4 for the application assertion.

4.2.1.4 chosen_method

The chosen_method specifies the Activity method used to carry out the Activity.

The chosen_method need not be specified for a particular Activity.

See 4.3.1 for the application assertion.

4.2.1.5 concerned_organization

The concerned_organization specifies the Organization (see 4.2.223) that is affected by the result of the Activity.

EXAMPLE The production site that has to change the process due to a design change activity is an example for concerned_organization.

See 4.3.10 for the application assertion.

4.2.1.6 description

The description specifies an alphanumeric string containing human-interpretable text that gives further details about the Activity.

The description need not be specified for a particular Activity.

4.2.1.7 id

The id specifies the identifier of the Activity.

4.2.1.8 internal

The internal specifies whether or not the Activity is performed internally within the organization. An Activity that is not performed internally is accomplished externally by another organization.

The internal need not be specified for a particular Activity.

4.2.1.9 planned_end_date

The planned_end_date specifies the date when the Activity is or was supposed to be finished.

The planned_end_date need not be specified for a particular Activity.

Each `planned_end_date` may be one of the following: `Date_time` (see 4.2.79), `Duration` (see 4.2.126), or `Event_reference` (see 4.2.130).

See 4.3.5, 4.3.7, and 4.3.8 for the application assertions.

4.2.1.10 `planned_start_date`

The `planned_start_date` specifies the date when the Activity is or was supposed to be started.

The `planned_start_date` need not be specified for a particular Activity.

Each `planned_start_date` may be one of the following: `Date_time` (see 4.2.79) or `Event_reference` (see 4.2.130).

See 4.3.6 and 4.3.9 for the application assertions.

4.2.1.11 `requestor`

The `requestor` specifies the party that requested the Activity and the date the request was submitted.

The `requestor` need not be specified for a particular Activity.

See 4.3.2 for the application assertion.

4.2.1.12 `resolved_request`

The `resolved_request` specifies the `Work_request` (see 4.2.365) that is resolved by the Activity.

See 4.3.12 for the application assertion.

4.2.1.13 `status`

The `status` specifies the level of completion of the Activity.

EXAMPLE An example of `status` is 'open'.

The `status` need not be specified for a particular Activity.

4.2.1.14 `supplying_organization`

The `supplying_organization` specifies the `Organization` (see 4.2.223) that carries out the work.

See 4.3.11 for the application assertion.

4.2.2 `Activity_element`

An `Activity_element` is an item of work that is part of an Activity (see 4.2.1).

ISO 10303-212:2001(E)

The data associated with an `Activity_element` are the following:

- `associated_activity`;
- `element`;
- `role`.

4.2.2.1 associated_activity

The `associated_activity` specifies the `Activity` (see 4.2.1) the `Activity_element` belongs to.

See 4.3.13 for the application assertion.

4.2.2.2 element

The `element` specifies the piece of product data that is under work.

Each `element` may be one of the following: `Activity_method` (see 4.2.3), `Activity_relationship` (see 4.2.5), `Alternate_item_relationship` (see 4.2.11), `Alternate_item_relationship` (see 4.2.11), `Assembly_component_relationship` (see 4.2.26), `Cable_pull_information` (see 4.2.33), `Class_category_association` (see 4.2.40), `Class_condition_association` (see 4.2.41), `Class_inclusion_association` (see 4.2.42), `Class_specification_association` (see 4.2.44), `Class_structure_relationship` (see 4.2.45), `Classification_system` (see 4.2.48), `Complex_product` (see 4.2.51), `Complex_product_relationship` (see 4.2.52), `Composition_relationship` (see 4.2.55), `Configuration` (see 4.2.56), `Connectivity_definition` (see 4.2.61), `Connectivity_definition_relationship` (see 4.2.62), `Data_element` (see 4.2.70), `Data_element_association` (see 4.2.71), `Data_element_definition` (see 4.2.72), `Data_element_relationship` (see 4.2.74), `Design_discipline_item_definition` (see 4.2.86), `Device` (see 4.2.88), `Device_relationship` (see 4.2.89), `Document` (see 4.2.101), `Document_file` (see 4.2.106), `Document_file_relationship` (see 4.2.107), `Document_representation` (see 4.2.110), `Document_version` (see 4.2.114), `Document_version_relationship` (see 4.2.115), `Drawing` (see 4.2.119), `Drawing_sequence` (see 4.2.121), `Drawing_sheet` (see 4.2.122), `Drawing_sheet_relationship` (see 4.2.124), `Function_definition` (see 4.2.145), `Function_definition_relationship` (see 4.2.146), `Function_interface` (see 4.2.147), `Function_unit` (see 4.2.148), `Function_unit_relationship` (see 4.2.149), `Function_version` (see 4.2.150), `Function_version_relationship` (see 4.2.151), `Functional_connectivity_definition` (see 4.2.152), `Functional_connectivity_definition_relationship` (see 4.2.153), `Generic_note` (see 4.2.159), `Interface` (see 4.2.170), `Interface_port` (see 4.2.171), `Interface_terminal` (see 4.2.174), `Item` (see 4.2.178), `Item_definition_relationship` (see 4.2.179), `Item_version` (see 4.2.182), `Item_version_relationship` (see 4.2.183), `Location` (see 4.2.192), `Location_relationship` (see 4.2.194), `Manufacturing_configuration` (see 4.2.198), `Marking` (see 4.2.199), `Node` (see 4.2.208), `Node_relationship` (see 4.2.209), `Notification` (see 4.2.213), `Notification_relationship` (see 4.2.214), `Path` (see 4.2.232), `Path_node` (see 4.2.233), `Path_node_relationship` (see 4.2.234), `Path_relationship` (see 4.2.235), `Physical_assembly_relationship` (see 4.2.241), `Physical_instance` (see 4.2.243), `Port` (see 4.2.247), `Process_variable` (see 4.2.260), `Process_variable_relationship` (see 4.2.261), `Product_class` (see 4.2.263), `Product_identification` (see 4.2.268), `Product_structure_relationship` (see 4.2.270), `Requirement` (see 4.2.285), `Route` (see 4.2.290), `Route_relationship` (see 4.2.291), `Section` (see 4.2.296), `Section_end` (see 4.2.297), `Section_interface` (see 4.2.298), `Section_interface_relationship` (see 4.2.299), `Section_relationship` (see 4.2.300), `Signal` (see 4.2.309), `Signal_relationship` (see 4.2.311), `Signal_value` (see 4.2.313), `Specification` (see 4.2.323), `Specification_category` (see 4.2.324), `Specification_expression` (see 4.2.326), `Specification_inclusion` (see 4.2.327),

Technical_system (see 4.2.336), Technical_system_relationship (see 4.2.337), or Terminal (see 4.2.338).

See 4.3.14, 4.3.15, 4.3.16, 4.3.17, 4.3.18, 4.3.19, 4.3.20, 4.3.21, 4.3.22, 4.3.23, 4.3.24, 4.3.25, 4.3.26, 4.3.27, 4.3.28, 4.3.29, 4.3.30, 4.3.31, 4.3.32, 4.3.33, 4.3.34, 4.3.35, 4.3.36, 4.3.37, 4.3.38, 4.3.39, 4.3.40, 4.3.41, 4.3.42, 4.3.43, 4.3.44, 4.3.45, 4.3.46, 4.3.47, 4.3.48, 4.3.49, 4.3.50, 4.3.51, 4.3.52, 4.3.53, 4.3.54, 4.3.55, 4.3.56, 4.3.57, 4.3.58, 4.3.59, 4.3.60, 4.3.61, 4.3.62, 4.3.63, 4.3.64, 4.3.65, 4.3.66, 4.3.67, 4.3.68, 4.3.69, 4.3.70, 4.3.71, 4.3.72, 4.3.73, 4.3.74, 4.3.75, 4.3.76, 4.3.77, 4.3.78, 4.3.79, 4.3.80, 4.3.81, 4.3.82, 4.3.83, 4.3.84, 4.3.85, 4.3.86, 4.3.87, 4.3.88, 4.3.89, 4.3.90, 4.3.91, 4.3.92, 4.3.93, 4.3.94, 4.3.95, 4.3.96, 4.3.97, 4.3.98, 4.3.99, 4.3.100, 4.3.101, 4.3.102, and 4.3.103 for the application assertions.

4.2.2.3 role

The role specifies the function that is performed by the Activity_element in the context of the concerned Activity (see 4.2.1). The value is either user defined or predefined.

The predefined value of relation_type is one of the following:

- control;
- input;
- output.

NOTE See 4.2.2.3.1 - 4.2.2.3.3 for the definition of each permissible value for role.

4.2.2.3.1 control

control: The referenced element is an object that has immediate influence on the Activity (see 4.2.1) performed.

EXAMPLE Design lots used in the design of a component that fulfils a given product function may be identified as Activity_element objects that refer to this Function_unit (see 4.2.148) in the role of 'control'.

4.2.2.3.2 input

input: The referenced element serves as initial data for the associated Activity (see 4.2.1) object.

4.2.2.3.3 output

output: The referenced element is the result of the associated Activity (see 4.2.1) object.

4.2.3 Activity_method

An Activity_method is a procedure that can be used to solve a problem.

ISO 10303-212:2001(E)

The data associated with an Activity_method are the following:

- consequence;
- description;
- name.

4.2.3.1 consequence

The consequence specifies the expected positive or negative effects of the application of a particular Activity_method.

The consequence need not be specified for a particular Activity_method.

4.2.3.2 description

The description specifies an alphanumeric string containing human-interpretable text that gives further details about the Activity_method.

4.2.3.3 name

The name specifies the identifier of the Activity_method.

4.2.4 Activity_method_assignment

An Activity_method_assignment is the relation that associates an Activity_method (see 4.2.3) with a Work_request (see 4.2.365). The associated Activity_method (see 4.2.3) serves as a recommended method to resolve the tasks specified in the Work_request (see 4.2.365).

The data associated with an Activity_element (see 4.2.2) are the following:

- assigned_method;
- assigned_work_request
- relation_type.

4.2.4.1 assigned_method

The assigned_method specifies the Activity_method (see 4.2.3).

See 4.3.104 for the application assertion.

4.2.4.2 assigned_work_request

The assigned_work_request specifies the Work_request (see 4.2.365).

See 4.3.105 for the application assertion.

4.2.4.3 relation_type

The `relation_type` specifies whether the specified `Activity_method` (see 4.2.3) may be used or not. The value is either user defined or predefined.

The predefined value of `relation_type` is one of the following:

- non recommended method;
- recommended method.

NOTE See 4.2.4.3.1 - 4.2.4.3.2 for the definition of each predefined value for `relation_type`.

4.2.4.3.1 non recommended method

non recommended method: The specified `Activity_method` (see 4.2.3) shall not be used in order to accomplish the specified `Work_request` (see 4.2.365).

4.2.4.3.2 recommended method

recommended method: The specified `Activity_method` (see 4.2.3) may be used in order to accomplish the specified `Work_request` (see 4.2.365).

NOTE Several alternative recommended methods may exist.

4.2.5 Activity_relationship

An `Activity_relationship` is the relation between two `Activity` (see 4.2.1) objects.

The data associated with an `Activity_relationship` are the following:

- description;
- related;
- relating;
- `relation_type`.

4.2.5.1 description

The description specifies an alphanumerical string containing human-interpretable text that gives further details about the `Activity_relationship`.

The description need not be specified for a particular `Activity_relationship`.

4.2.5.2 related

The related specifies the second of the two `Activity` (see 4.2.1) objects related by an `Activity_relationship`.

NOTE The semantic of this attribute is defined by the attribute `relation_type`.

See 4.3.106 for the application assertion.

4.2.5.3 relating

The relating specifies the first of the two Activity (see 4.2.1) objects related by an Activity_ - relationship.

NOTE The semantic of this attribute is defined by the attribute relation_type.

See 4.3.107 for the application assertion.

4.2.5.4 relation_type

The relation_type specifies the meaning of the relationship. The value is either user defined or predefined.

The predefined value of relation_type is one of the following:

- alternative;
- decomposition;
- derivation;
- exclusiveness;
- precedence;
- sequence;
- simultaneity.

NOTE See 4.2.5.4.1 - 4.2.5.4.7 for the definition of each predefined value for relation_type.

4.2.5.4.1 alternative

alternative: The application object defines a relationship where the related Activity (see 4.2.1) may be used alternatively instead of the relating Activity (see 4.2.1).

4.2.5.4.2 decomposition

decomposition: The Activity_relationship defines a relationship where the related Activity (see 4.2.1) is one of the components into which the relating Activity (see 4.2.1) is broken down.

4.2.5.4.3 derivation

derivation: The Activity_relationship defines a relationship where the related Activity (see 4.2.1) is derived from the relating Activity (see 4.2.1).

EXAMPLE An Activity (see 4.2.1) controlled by a Work_order (see 4.2.364) with work order type 'manufacturing release' can be derived from another Activity (see 4.2.1) controlled by another Work_order (see 4.2.364) with work order type 'design release'.

4.2.5.4.4 exclusiveness

exclusiveness: The application object defines a relationship where the relating and the related Activity (see 4.2.1) shall not have any overlap in time of execution.

4.2.5.4.5 precedence

precedence: The Activity_relationship defines a relationship where the related Activity (see 4.2.1) has higher priority than the relating Activity (see 4.2.1).

4.2.5.4.6 sequence

sequence: The Activity_relationship defines a relationship where the relating Activity (see 4.2.1) shall be completed before the related Activity (see 4.2.1) starts.

4.2.5.4.7 simultaneity

simultaneity: The Activity_relationship defines a relationship where the related Activity (see 4.2.1) is carried out simultaneously with the relating Activity (see 4.2.1).

4.2.6 Address

An Address is the place where people and organizations are located.

ISO 10303-212:2001(E)

The data associated with an Address are the following:

- country;
- email_address;
- fax_number;
- internal_location;
- postal_box;
- postal_code;
- region;
- street;
- street_number;
- telephone_number;
- telex_number;
- town.

4.2.6.1 country

The country specifies the name of a nation.

The country need not be specified for a particular Address.

4.2.6.2 email_address

The email_address specifies the sequence of characters that make up the appropriate address for electronic mail.

The email_address need not be specified for a particular Address.

4.2.6.3 fax_number

The fax_number specifies the number at which facsimiles can be received.

The fax_number need not be specified for a particular Address.

4.2.6.4 internal_location

The internal_location specifies the organization-defined address for internal mail delivery.

The internal_location need not be specified for a particular Address.

4.2.6.5 postal_box

The `postal_box` specifies the number of the appropriate post office box.

The `postal_box` need not be specified for a particular Address.

4.2.6.6 postal_code

The `postal_code` specifies the code that is used by the local postal service.

The `postal_code` need not be specified for a particular Address.

4.2.6.7 region

The `region` specifies the name of the area.

The `region` need not be specified for a particular Address.

4.2.6.8 street

The `street` specifies the name of the road.

The `street` need not be specified for a particular Address.

4.2.6.9 street_number

The `street_number` specifies the number of the building in a street.

The `street_number` need not be specified for a particular Address.

4.2.6.10 telephone_number

The `telephone_number` specifies the number at which telephone calls can be received.

The `telephone_number` need not be specified for a particular Address.

4.2.6.11 telex_number

The `telex_number` specifies the number at which telex messages can be received.

The `telex_number` need not be specified for a particular Address.

4.2.6.12 town

The `town` specifies the name of a city.

The `town` need not be specified for a particular Address.

4.2.7 Aggregated_value

An `Aggregated_value` is a type of `Data_element_value` (see 4.2.76) that is used to organize the values of a `Data_element` (see 4.2.70) as a list or as an array. The meaning of the order of the associated values shall be defined in the associated `Data_element_definition` (see 4.2.72).

ISO 10303-212:2001(E)

NOTE Multidimensional arrays are created through nesting Aggregated_value objects.

The data associated with an Aggregated_value are the following:

— member_definition.

4.2.7.1 member_definition

The member_definition specifies the constituents of Aggregated_value.

See 4.3.108 for the application assertion.

4.2.8 Alias_designation

An Alias_designation is the mechanism to associate an object with an additional designation that is used to identify the object of interest in a different context, either in another Organization (see 4.2.223), or in some other context. The Alias_designation allows to specify structured labels where the semantic of each composite can be identified. The scope of the Alias_designation shall be specified either by the attribute 'alias_scope' or by the attribute 'description'.

NOTE The Alias_designation allows to assign an alias name that is not just a simple string but a designation equipped with the information provided by the Object_designation (see 4.2.217) object.

EXAMPLE An relais may be designated as '=A00-K1' in the context of the supplier and as '=N005.A00-K1' in the context of the customer.

The data associated with an Alias_designation are the following:

— alias_extended_designation;

— alias_scope;

— description;

— is_applied_to.

4.2.8.1 alias_extended_designation

The alias_extended_designation specifies the designator. The designator may be a structured label.

See 4.3.115 for the application assertion.

4.2.8.2 alias_scope

The alias_scope specifies the Organization (see 4.2.223) in which the Alias_designation is valid.

The alias_scope need not be specified for a particular Alias_designation.

See 4.3.116 for the application assertion.

4.2.8.3 description

The description specifies the kind of the Alias_designation.

EXAMPLE The description may be 'preliminary designation'.

The description need not be specified for a particular Alias_designation.

4.2.8.4 is_applied_to

The is_applied_to specifies the object that has an Alias_designation.

Each is_applied_to may be one of the following: Device (see 4.2.88), Document_representation (see 4.2.110), Drawing (see 4.2.119), Drawing_sheet (see 4.2.122), Function_unit (see 4.2.148), Location (see 4.2.192), Port (see 4.2.247), Product_component (see 4.2.265), Signal (see 4.2.309), Technical_system (see 4.2.336), or Terminal (see 4.2.338).

See 4.3.109, 4.3.110, 4.3.111, 4.3.112, 4.3.113, 4.3.114, 4.3.117, 4.3.118, 4.3.119, 4.3.120, and 4.3.121 for the application assertions.

4.2.9 Alias_identification

An Alias_identification is the mechanism to associate an object with an additional identifier that is used to identify the object of interest in a different context, either in another Organization (see 4.2.223), or in some other context. The scope of the Alias_identification shall be specified either by the attribute 'alias_scope' or by the attribute 'description'.

NOTE The identifier may be used to identify the object of interest in a different context, either in another Organization (see 4.2.223), or in some other context.

EXAMPLE A book may have a unique document id (ISBN) and an Alias_identification as an inventory number in the context of the inventory of a company.

The data associated with an Alias_identification are the following:

- alias_id;
- alias_scope;
- description;
- is_applied_to.

4.2.9.1 alias_id

The alias_id specifies the identifier used in the context specified by alias_scope, description, or both.

4.2.9.2 alias_scope

The alias_scope specifies the Organization (see 4.2.223) in which the Alias_identification is valid.

The alias_scope need not be specified for a particular Alias_identification.

See 4.3.149 for the application assertion.

4.2.9.3 description

The description specifies the kind of the `Alias_identification`.

EXAMPLE The description may be 'inventory number'.

The description need not be specified for a particular `Alias_identification`.

4.2.9.4 is_applied_to

The `is_applied_to` specifies the object that has an `Alias_identification`.

Each `is_applied_to` may be one of the following: `Approval_status` (see 4.2.25), `Classification_attribute` (see 4.2.47), `Classification_system` (see 4.2.48), `Complex_product` (see 4.2.51), `Component_colour` (see 4.2.53), `Connectivity_definition` (see 4.2.61), `Data_element_definition` (see 4.2.72), `Design_discipline_item_definition` (see 4.2.86), `Device` (see 4.2.88), `Document` (see 4.2.101), `Document_representation` (see 4.2.110), `Document_type_property` (see 4.2.113), `Document_version` (see 4.2.114), `Drawing` (see 4.2.119), `Drawing_sheet` (see 4.2.122), `Function_definition` (see 4.2.145), `Function_unit` (see 4.2.148), `Functional_connectivity_definition` (see 4.2.152), `Functionality` (see 4.2.155), `General_classification` (see 4.2.156), `Interface_port` (see 4.2.171), `Interface_terminal` (see 4.2.174), `Item` (see 4.2.178), `Item_version` (see 4.2.182), `Location` (see 4.2.192), `Node` (see 4.2.208), `Notification` (see 4.2.213), `Organization` (see 4.2.223), `Path` (see 4.2.232), `Path_node` (see 4.2.233), `Physical_instance` (see 4.2.243), `Port` (see 4.2.247), `Process_variable` (see 4.2.260), `Product_class` (see 4.2.263), `Product_identification` (see 4.2.268), `Requirement` (see 4.2.285), `Route` (see 4.2.290), `Section` (see 4.2.296), `Section_interface` (see 4.2.298), `Security_level` (see 4.2.302), `Signal` (see 4.2.309), `Specification` (see 4.2.323), `Specification_category` (see 4.2.324), `Technical_system` (see 4.2.336), or `Terminal` (see 4.2.338).

See 4.3.122, 4.3.123, 4.3.124, 4.3.125, 4.3.126, 4.3.127, 4.3.128, 4.3.129, 4.3.130, 4.3.131, 4.3.132, 4.3.133, 4.3.134, 4.3.135, 4.3.136, 4.3.137, 4.3.138, 4.3.139, 4.3.140, 4.3.141, 4.3.142, 4.3.143, 4.3.144, 4.3.145, 4.3.146, 4.3.147, 4.3.148, 4.3.150, 4.3.151, 4.3.152, 4.3.153, 4.3.154, 4.3.155, 4.3.156, 4.3.157, 4.3.158, 4.3.159, 4.3.160, 4.3.161, 4.3.162, 4.3.163, 4.3.164, 4.3.165, 4.3.166, and 4.3.167 for the application assertions.

4.2.10 Alias_version

An `Alias_version` is a particular version of the object to which the associated alias identifier applies.

NOTE 1 The scope of the `Alias_version` is specified either through the 'alias_scope' attribute of the associated `Alias_identification` (see 4.2.9) object or `Alias_designation` (see 4.2.8) object.

NOTE 2 An `Alias_version` may be applied only if the object of interest may carry an optional or mandatory version. If so, an `Alias_version` may be assigned even if the object of interest does not yet have a version assigned.

The data associated with an `Alias_version` are the following:

- `associated_alias_id`;
- `version_id`.

4.2.10.1 associated_alias_id

The `associated_alias_id` specifies the identifier.

Each `associated_alias_id` may be one of the following: `Alias_designation` (see 4.2.8) or `Alias_identification` (see 4.2.9).

See 4.3.168 and 4.3.169 for the application assertions.

4.2.10.2 version_id

The `version_id` specifies the version of the object as known in the context of the alias identifier.

4.2.11 Alternate_item_relationship

An `Alternate_item_relationship` is the relationship between two `Item` (see 4.2.178) objects specifying that all versions of the two related `Item` (see 4.2.178) objects are interchangeable independent from their context of use.

NOTE 1 Interchangeability usually refers to form, fit, function, and quality. Additional properties, such as performance, noise, endurance, or reliability, may also be considered as a prerequisite for the interchangeability.

NOTE 2 If more than one `Alternate_item_relationship` is in place, the union of the attributes `fulfilled_requirements` is the criteria for the interchangeability.

EXAMPLE The `Alternate_item_relationship` indicates that an amplifier XX741 may be replaced by an amplifier YY741 from another manufacturer.

The two `Item` (see 4.2.178) objects are interchangeable in both directions.

ISO 10303-212:2001(E)

The data associated with an `Alternate_item_relationship` are the following:

- `alternate`;
- `base`;
- `fulfilled_requirements`.

4.2.11.1 `alternate`

The `alternate` specifies the `Item` (see 4.2.178) that may be used in place of the base `Item` (see 4.2.178).

See 4.3.170 for the application assertion.

4.2.11.2 `base`

The `base` specifies the `Item` (see 4.2.178) for which another `Item` (see 4.2.178) may be used as an `alternate`.

See 4.3.171 for the application assertion.

4.2.11.3 `fulfilled_requirements`

The `fulfilled_requirements` specifies the word or group of words describing the requirements that are covered by both the `base` and the `alternate` and are, therefore, the basis for the statement of interchangeability.

4.2.12 `Alternative_solution`

An `Alternative_solution` is a type of `Complex_product` (see 4.2.51) that is the design of one of potentially many mutually exclusive implementation options. An `Alternative_solution` may refer directly to the object to be implemented or through another `Alternative_solution`, in which case, it serves as a refinement of that `Alternative_solution`.

The data associated with an `Alternative_solution` are the following:

- `base_element`.

4.2.12.1 `base_element`

The `base_element` specifies the physical or functional object, for which the `Alternative_solution` provides a design alternative. All `Alternative_solution` objects for the same `base_element` are mutually exclusive.

Each `base_element` may be one of the following: `Alternative_solution`, `Function_definition` (see 4.2.145), `Product_component` (see 4.2.265), or `Single_function_unit` (see 4.2.315).

See 4.3.172, 4.3.173, 4.3.174, and 4.3.175 for the application assertions.

4.2.13 Angular_dimension

An `Angular_dimension` is a type of `Dimension` (see 4.2.93) that is the graphical presentation of a value of the angle between two elements that converge on a common point or line.

The data associated with an `Angular_dimension` are the following:

- `component`;
- `extent`.

4.2.13.1 component

The `component` specifies the projection lines that show the extension of the points, lines, or surfaces that bound the measurement.

See 4.3.177 for the application assertion.

4.2.13.2 extent

The `extent` specifies the dimension line that graphically presents where the dimension value applies.

See 4.3.176 for the application assertion.

4.2.14 Annotation_curve

An `Annotation_curve` is a type of `Annotation_element` (see 4.2.15) that is a two-dimensional trimmed curve used only to annotate a drawing or a draughting shape model and that is defined in the coordinate system in which it is used.

The data associated with an `Annotation_curve` are the following:

- `assigned_appearance`.

4.2.14.1 assigned_appearance

The `assigned_appearance` specifies the presentation aspects of an `Annotation_curve`.

See 4.3.178 for the application assertion.

4.2.15 Annotation_element

An `Annotation_element` is a type of `Draughting_annotation` (see 4.2.116) that is the lowest level discrete element that can either serve as an annotation itself, or be used as a constituent of other annotations.

Each `Annotation_element` is either an `Annotation_curve` (see 4.2.14), an `Annotation_subfigure` (see 4.2.17), an `Annotation_symbol` (see 4.2.20), a `Fill_area` (see 4.2.139), a `Schematic_node` (see 4.2.294), or a `Text` (see 4.2.342).

4.2.16 Annotation_placed_annotation

ISO 10303-212:2001(E)

An `Annotation_placed_annotation` is a type of `Draughting_annotation` (see 4.2.116) that is located in the coordinate system of a symbol or subfigure.

4.2.17 `Annotation_subfigure`

An `Annotation_subfigure` is a type of `Annotation_element` (see 4.2.15) that is the visual instance of an `Annotation_subfigure_definition` (see 4.2.18) located within the coordinate system of a drawing sheet, a drawing view, a draughting model, or another subfigure.

The data associated with an `Annotation_subfigure` are the following:

- definition;
- position;
- rotation;
- scale.

4.2.17.1 definition

The definition specifies the template from which the `Annotation_subfigure` is derived.

See 4.3.179 for the application assertion.

4.2.17.2 position

The position specifies the location of the origin of the coordinate system in which the subfigure is defined relative to the origin of the coordinate system into which the subfigure is being placed.

See 4.3.180 for the application assertion.

4.2.17.3 rotation

The rotation specifies the angle, measured counter-clockwise, between the horizontal axis of the coordinate system in which the subfigure is defined and the horizontal axis of the coordinate system into which the subfigure is being placed.

4.2.17.4 scale

The scale specifies the ratio between the size of the subfigure as defined and the size of the subfigure as presented.

4.2.18 `Annotation_subfigure_definition`

An `Annotation_subfigure_definition` is a collection of defined annotation elements, along with their placements, in a coordinate space.

The data associated with an `Annotation_subfigure_definition` are the following:

- `blanking_box`;
- `coordinate_space`;
- `name`.

4.2.18.1 `blanking_box`

The `blanking_box` specifies an area that the `Annotation_subfigure_definition` occupies and is used to suppress the visual presentation of all other elements that are within this area.

The `blanking_box` need not be specified for a particular `Annotation_subfigure_definition`.

See 4.3.182 for the application assertion.

4.2.18.2 `coordinate_space`

The `coordinate_space` specifies the coordinate system that describes the two-dimensional space in which the constituents of the `Annotation_subfigure_definition` are located.

See 4.3.181 for the application assertion.

4.2.18.3 `name`

The `name` specifies the identifier of the `Annotation_subfigure_definition`.

The `name` need not be specified for a particular `Annotation_subfigure_definition`.

4.2.19 `Annotation_subfigure_definition_element`

An `Annotation_subfigure_definition_element` is an annotation that is used as a constituent of a subfigure definition.

The data associated with an `Annotation_subfigure_definition_element` are the following:

- `annotation_layers`;
- `annotation_visibility`;
- `containing_definition`;
- `used_annotation`.

4.2.19.1 `annotation_layers`

The `annotation_layers` specifies the draughting layers that contain the annotation.

See 4.3.185 for the application assertion.

4.2.19.2 `annotation_visibility`

ISO 10303-212:2001(E)

The `annotation_visibility` specifies whether or not each element of a subfigure is visible.

See 4.3.186 for the application assertion.

4.2.19.3 `containing_definition`

The `containing_definition` specifies the subfigure definition in which the annotation is placed.

See 4.3.184 for the application assertion.

4.2.19.4 `used_annotation`

The `used_annotation` specifies the annotation that is an element of the subfigure.

See 4.3.183 for the application assertion.

4.2.20 `Annotation_symbol`

An `Annotation_symbol` is a type of `Annotation_element` (see 4.2.15) that is the presentation of a symbol definition that is either externally defined, predefined, or defined explicitly as a combination of annotation elements. The `Annotation_symbol` is located within the coordinate system of a drawing sheet, drawing view, or another symbol.

Each `Annotation_symbol` is either an `Externally_defined_symbol` (see 4.2.135), a `Predefined_symbol` (see 4.2.255), or a `User_defined_symbol` (see 4.2.354).

The data associated with an `Annotation_symbol` are the following:

- `blanking_box`;
- `overriding_colour`;
- `position`;
- `rotation`;
- `scale`.

4.2.20.1 `blanking_box`

The `blanking_box` specifies an area that the `Annotation_element` (see 4.2.15) occupies and is used to suppress the visual presentation of all other elements that are within this area.

The `blanking_box` need not be specified for a particular `Annotation_symbol`.

See 4.3.189 for the application assertion.

4.2.20.2 `overriding_colour`

The `overriding_colour` specifies the colour definition that overrides the appearance characteristics already assigned to the elements of the symbol.

The overriding_colour need not be specified for a particular Annotation_symbol.

See 4.3.187 for the application assertion.

4.2.20.3 position

The position specifies the location of the origin of the coordinate system in which the symbol is defined relative to the origin of the coordinate system into which the symbol is being placed.

See 4.3.188 for the application assertion.

4.2.20.4 rotation

The rotation specifies the angle, measured counter-clockwise, between the positive x-axis of the coordinate system in which the symbol is defined and the positive x-axis of the coordinate system into which the symbol is being placed.

4.2.20.5 scale

The scale specifies the ratio between the size of the symbol as defined and the size of the symbol as presented. The scale in the x-coordinate need not equal the scale in the y-coordinate.

4.2.21 Appearance

An Appearance is a collection of visual characteristics that govern the presentation of geometric elements or annotation elements.

Each Appearance is either a Curve_appearance (see 4.2.68), a Fill_area_appearance (see 4.2.140), or a Text_appearance (see 4.2.343).

4.2.22 Application_context

An Application_context is a context in which product data is defined. An Application_context represents various types of information that relate to product data and may affect the meaning and usage of that data.

The data associated with an Application_context are the following:

- application_domain;
- description;
- life_cycle_stage.

4.2.22.1 application_domain

The application_domain is the identification of the discipline for which the product data is relevant.

EXAMPLE Examples for application_domain are 'electrical design' or 'engineering analysis'.

4.2.22.2 description

ISO 10303-212:2001(E)

The description specifies an alphanumerical string containing human-interpretable text that gives further details about the Application_context.

The description need not be specified for a particular Application_context.

4.2.22.3 life_cycle_stage

The life_cycle_stage is the specification of the general stage in the product life cycle to which the product data belong. The value is either user defined or predefined.

The predefined value of life_cycle_stage is one of the following:

- conceptual design;
- development;
- implementation;
- operation;
- test.

NOTE See 4.2.22.3.1 - 4.2.22.3.5 for the definition of each predefined value for life_cycle_stage.

4.2.22.3.1 conceptual design

conceptual design: The object that refers the Application_context object is in the stage of transforming the customer's requirements into a draft design.

4.2.22.3.2 development

development: The object that refers the Application_context object is in the stage of transforming the conceptual design into an implementable system.

4.2.22.3.3 implementation

implementation: The object that refers the Application_context object is in the stage of realization.

4.2.22.3.4 operation

operation: The object that refers the Application_context object is in the stage of productive use.

4.2.22.3.5 test

test: The object that refers the Application_context object is in the stage of verification whether it satisfies the specified requirements.

4.2.23 Approval

An Approval is a judgement concerning the quality of product data that are subject of the Approval. An Approval represents a statement made by technical personnel or management personnel if certain requirements are met.

The data associated with an Approval are the following:

- actual_date;
- is_applied_to;
- is_approved_by;
- level;
- planned_date;
- scope;
- status.

4.2.23.1 actual_date

The actual_date specifies the date when the Approval was actually performed. If this information is absent, the approval has not yet occurred, i.e., it is pending.

The actual_date need not be specified for a particular Approval.

See 4.3.220 for the application assertion.

4.2.23.2 is_applied_to

The is_applied_to specifies the object to which the Approval is assigned.

Each is_applied_to may be one of the following: Activity (see 4.2.1), Activity_element (see 4.2.2), Activity_method_assignment (see 4.2.4), Activity_relationship (see 4.2.5), Alternate_item_relationship (see 4.2.11), Alternate_item_relationship (see 4.2.11), Assembly_component_relationship (see 4.2.26), Cable_pull_information (see 4.2.33), Certification (see 4.2.38), Class_category_association (see 4.2.40), Class_condition_association (see 4.2.41), Class_inclusion_association (see 4.2.42), Class_specification_association (see 4.2.44), Class_structure_relationship (see 4.2.45), Classification_association (see 4.2.46), Classification_system (see 4.2.48), Complex_product (see 4.2.51), Complex_product_relationship (see 4.2.52), Composition_relationship (see 4.2.55), Configuration (see 4.2.56), Connectivity_allocation (see 4.2.60), Connectivity_definition (see 4.2.61), Connectivity_definition_relationship (see 4.2.62), Contract (see 4.2.63), Data_element (see 4.2.70), Data_element_association (see 4.2.71), Data_element_definition (see 4.2.72), Data_element_relationship (see 4.2.74), Design_discipline_item_definition (see 4.2.86), Device (see 4.2.88), Device_relationship (see 4.2.89), Document (see 4.2.101), Document_file (see 4.2.106), Document_file_relationship (see 4.2.107), Document_representation (see 4.2.110), Document_version (see 4.2.114), Document_version_relationship (see 4.2.115), Drawing (see 4.2.119), Drawing_sequence (see 4.2.121), Drawing_sheet (see 4.2.122), Drawing_sheet_relationship (see 4.2.124), Function_definition (see 4.2.145), Function_definition_relationship (see 4.2.146), Function_interface (see 4.2.147), Function_unit (see 4.2.148), Function_unit_relationship (see 4.2.149), Function_version (see 4.2.150), Function_version_relationship (see 4.2.151), Functional_connectivity_definition (see 4.2.152), Functional_connectivity_definition_relationship (see 4.2.153), Functional_unit_allocation (see 4.2.154), General_classification (see 4.2.156), Generic_note (see 4.2.159), Interface (see 4.2.170), Interface_port (see 4.2.171), Interface_terminal (see 4.2.174), Item_definition_relationship (see 4.2.179), Item_version (see 4.2.182), Item_version_relationship

ISO 10303-212:2001(E)

(see 4.2.183), Location (see 4.2.192), Location_relationship (see 4.2.194), Manufacturing_configuration (see 4.2.198), Marking (see 4.2.199), Material (see 4.2.201), Node (see 4.2.208), Node_relationship (see 4.2.209), Notification (see 4.2.213), Notification_relationship (see 4.2.214), Offered_function_allocation (see 4.2.220), Path (see 4.2.232), Path_node (see 4.2.233), Path_node_relationship (see 4.2.234), Path_relationship (see 4.2.235), Physical_assembly_relationship (see 4.2.241), Physical_instance (see 4.2.243), Port (see 4.2.247), Port_allocation (see 4.2.248), Preferred_item_allocation (see 4.2.258), Preferred_item_terminal_allocation (see 4.2.259), Process_variable (see 4.2.260), Process_variable_relationship (see 4.2.261), Product_class (see 4.2.263), Product_identification (see 4.2.268), Product_structure_relationship (see 4.2.270), Project (see 4.2.271), Requirement (see 4.2.285), Route (see 4.2.290), Route_relationship (see 4.2.291), Section (see 4.2.296), Section_end (see 4.2.297), Section_interface (see 4.2.298), Section_interface_relationship (see 4.2.299), Section_relationship (see 4.2.300), Security_classification (see 4.2.301), Signal (see 4.2.309), Signal_relationship (see 4.2.311), Signal_value (see 4.2.313), Specification (see 4.2.323), Specification_category (see 4.2.324), Specification_expression (see 4.2.326), Specification_inclusion (see 4.2.327), Technical_system (see 4.2.336), Technical_system_relationship (see 4.2.337), Terminal (see 4.2.338), Work_order (see 4.2.364), or Work_request (see 4.2.365).

See 4.3.190, 4.3.191, 4.3.192, 4.3.193, 4.3.194, 4.3.195, 4.3.197, 4.3.198, 4.3.199, 4.3.200, 4.3.201, 4.3.202, 4.3.203, 4.3.204, 4.3.205, 4.3.206, 4.3.207, 4.3.208, 4.3.209, 4.3.210, 4.3.211, 4.3.212, 4.3.213, 4.3.214, 4.3.215, 4.3.216, 4.3.217, 4.3.218, 4.3.222, 4.3.223, 4.3.224, 4.3.225, 4.3.226, 4.3.227, 4.3.228, 4.3.229, 4.3.230, 4.3.231, 4.3.232, 4.3.233, 4.3.234, 4.3.235, 4.3.236, 4.3.237, 4.3.238, 4.3.239, 4.3.240, 4.3.241, 4.3.242, 4.3.243, 4.3.244, 4.3.245, 4.3.246, 4.3.247, 4.3.248, 4.3.249, 4.3.250, 4.3.251, 4.3.252, 4.3.253, 4.3.254, 4.3.255, 4.3.256, 4.3.257, 4.3.258, 4.3.259, 4.3.260, 4.3.261, 4.3.262, 4.3.264, 4.3.265, 4.3.266, 4.3.267, 4.3.268, 4.3.269, 4.3.270, 4.3.271, 4.3.272, 4.3.273, 4.3.274, 4.3.275, 4.3.276, 4.3.277, 4.3.278, 4.3.279, 4.3.280, 4.3.281, 4.3.282, 4.3.283, 4.3.284, 4.3.285, 4.3.286, 4.3.287, 4.3.288, 4.3.289, 4.3.290, 4.3.291, 4.3.292, 4.3.293, 4.3.294, 4.3.295, 4.3.296, 4.3.297, 4.3.298, 4.3.299, and 4.3.300 for the application assertions.

4.2.23.3 is_approved_by

The `is_approved_by` specifies the Person (see 4.2.237) or Organization (see 4.2.223) responsible for the Approval and the date when the authorization was granted.

See 4.3.219 for the application assertion.

4.2.23.4 level

The level indicates the kind of activity that may be performed. The value is either user defined or predefined.

The predefined value of level is one of the following:

- disposition;
- equipment order;
- planning.

NOTE See 4.2.23.4.1 - 4.2.23.4.3 for the definition of each predefined value for level.

4.2.23.4.1 disposition

disposition: The approved item is approved for series production.

4.2.23.4.2 equipment_order

equipment_order: The approved item has reached the status in which changes are subject to a defined change process so that tools and other equipment for the production may be ordered.

4.2.23.4.3 planning

planning: The approved item is technically complete and has reached the status sufficiently stable so that other designs may be based on it.

The level need not be specified for a particular Approval.

4.2.23.5 planned_date

The planned_date specifies the date when the Approval is or was supposed to be performed.

The planned_date need not be specified for a particular Approval.

See 4.3.221 for the application assertion.

4.2.23.6 scope

The scope specifies the set of Organization (see 4.2.223) objects for which the Approval is valid.

See 4.3.263 for the application assertion.

4.2.23.7 status

The status specifies the judgement made about the product data that is the subject of this Approval.

See 4.3.196 for the application assertion.

4.2.24 Approval_relationship

An Approval_relationship is the relation between two Approval (see 4.2.23) objects.

ISO 10303-212:2001(E)

The data associated with an Approval_relationship are the following:

- description;
- related;
- relating;
- relation_type.

4.2.24.1 description

The description specifies an alphanumeric string containing human-interpretable text that gives further details about the Approval_relationship.

The description need not be specified for a particular Approval_relationship.

4.2.24.2 related

The related specifies the second of the two Approval (see 4.2.23) objects related by the Approval_relationship.

NOTE The semantic of this attribute is defined by the attribute relation_type.

See 4.3.301 for the application assertion.

4.2.24.3 relating

The relating specifies the first of the two Approval (see 4.2.23) objects related by the Approval_relationship.

NOTE The semantic of this attribute is defined by the attribute relation_type.

See 4.3.302 for the application assertion.

4.2.24.4 relation_type

The relation_type specifies the meaning of the relationship. The value is either user defined or predefined.

The value of `relation_type` is one of the following:

- decomposition;
- sequence;
- precedence.

NOTE See 4.2.24.4.1 - 4.2.24.4.3 for the definition of each predefined value for `relation_type`.

4.2.24.4.1 decomposition

decomposition: The `Approval_relationship` defines a relationship where the related `Approval` (see 4.2.23) is one of the components into which the relating `Approval` (see 4.2.23) is broken down.

4.2.24.4.2 sequence

sequence: The `Approval_relationship` defines a relationship where the relating `Approval` (see 4.2.23) shall be completed before the related `Approval` (see 4.2.23) is given.

4.2.24.4.3 precedence

precedence: The `Approval_relationship` defines a relationship where the related `Approval` (see 4.2.23) has higher priority than the relating `Approval` (see 4.2.23).

4.2.25 Approval_status

An `Approval_status` is the state of acceptance of some product data.

The value is either user defined or predefined. The data associated with an `Approval_status` are the following:

- `status_name`;
- `used_classification_system`.

4.2.25.1 status_name

The `status_name` specifies the word or abbreviation that is used to refer to the `Approval_status`. The value is either user defined or predefined.

The predefined value of `status_name` is one of the following:

- approved;
- disapproved;
- withdrawn.

NOTE See 4.2.25.1.1 - 4.2.25.1.3 for the definition of each permissible value for `status_name`.

4.2.25.1.1 approved

ISO 10303-212:2001(E)

approved: The fact that the judgement on the referenced element is positive.

4.2.25.1.2 disapproved

disapproved: The fact that the judgement on the referenced element is negative.

4.2.25.1.3 withdrawn

withdrawn: The fact that the referenced element was cancelled.

4.2.25.2 used_classification_system

The used_classification_system specifies the Classification_system (see 4.2.48) that contains the information about how to interpret the Approval (see 4.2.23) status.

The used_classification_system need not be specified for a particular Approval status.

See 4.3.303 for the application assertion.

4.2.26 Assembly_component_relationship

An Assembly_component_relationship is the relation between an Assembly_definition (see 4.2.27) and a Device (see 4.2.88). The Device (see 4.2.88) represents a constituent of the assembly or package.

NOTE 1 The constituent may also be an assembly.

NOTE 2 The same instance of Device (see 4.2.88) may be a constituent of more than one assembly defined through the Design_discipline_item_definition (see 4.2.86) object.

NOTE 3 An assembly may be regarded to be a package of things that belong together for some purpose. Following that idea, devices may belong to more than one of such a package. This part of ISO 10303 does not constrain the Assembly_component_relationship between the packages. One may be a subset of another, they may be disjoint, or they may partially overlap.

EXAMPLE 1 The power supply cord of an overhead projector may belong at the same time to the sales package of the projector and to the package of power supply cords that are currently in stock.

EXAMPLE 2 In Figure 7, the structure of a simple assembly is given to show how this part of ISO 10303 is to be used to specify hierarchically composed pieces of equipment. A pilot lamp is shown which is composed of the lamp L1 and the resistors R1 and R2. The connections W1 and W2 perform the internal connectivity. Templates for the lamp and the resistors exist (L and R) that characterize the properties of the components, which are independent from the context of usage, e.g., specification sheet parameters.

Two instances of Design_discipline_item_definition (see 4.2.86) represent the templates R and L. The template L has two instances of Interface_terminal (see 4.2.174) assigned to it, in order to characterize its two connect nodes. The connect nodes are indicated in the figure by triangles. The same applies to template R.

L1 is an occurrence of L, and R1 and R2 are occurrences of R. L1, R2, and R3 are represented by Device (see 4.2.88) objects which are associated by their 'definition' attributes with the Design_discipline_item_definition (see 4.2.86) representing L respectively R. The connect nodes of L1, R1, and R2 are characterized through Terminal (see 4.2.338) objects. Figure 7 shows the six instances of the object Terminal (see 4.2.338) (indicated by an 'x'). Each of the Terminal (see 4.2.338) object is associated with an Interface_terminal (see 4.2.174) through the 'associated_interface_terminal' attribute. The connectivity is performed by the Connection (see 4.2.59) objects W1 and W2 that link the appropriate Terminal (see 4.2.338) objects.

An instance of Assembly_definition (see 4.2.27), which is a subtype of Design_discipline_item_definition (see 4.2.86), specifies the pilot lamp. Three instances of Next_higher_assembly (see 4.2.207) express that this assembly is made from L1, R1, and R2. To express the association between the Interface_terminal (see 4.2.174) objects of the pilot lamp and its appropriate counterpart at the next lower level of detail, the 'uses' attribute of Interface_terminal (see 4.2.174) is employed. The curved arrows in the figure symbolize these associations.

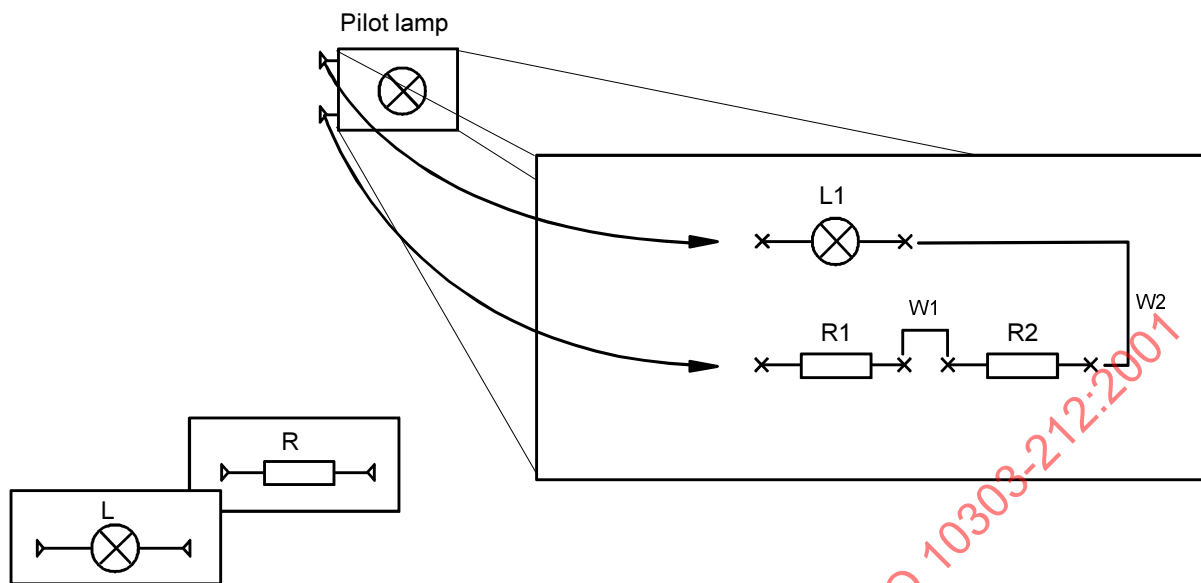

Figure 7 - Hierarchical composition

Each `Assembly_component_relationship` is either a `Next_higher_assembly` (see 4.2.207) or a `Promissory_usage` (see 4.2.274).

The data associated with an `Assembly_component_relationship` are the following:

- placement;
- related;
- relating.

4.2.26.1 placement

The placement specifies the geometrical transformation that is used to calculate the spatial position of the constituent within the assembly.

The placement need not be specified for a particular `Assembly_component_relationship`.

4.2.26.2 related

The related specifies the `Device` (see 4.2.88) that acts as a component.

See 4.3.305 for the application assertion.

4.2.26.3 relating

The relating specifies the `Assembly_definition` (see 4.2.27) that has subordinate constituents.

See 4.3.304 for the application assertion.

4.2.27 Assembly_definition

An `Assembly_definition` is a type of `Design_discipline_item_definition` (see 4.2.86) that is the definition of an `Item_version` (see 4.2.182) that contains other subordinate `Item_version` (see 4.2.182) objects.

NOTE An `Assembly_definition` can be used to define items such as an assembled module or a procurement package.

EXAMPLE A procurement package consists of a power transformer together with its mounting material.

The data associated with an `Assembly_definition` are the following:

— `assembly_type`.

4.2.27.1 `assembly_type`

The `assembly_type` specifies the kind of the `Assembly_definition`.

EXAMPLE 'functional assembly', 'manufacturing assembly', and 'design assembly' are examples of an `assembly_type`.

The `assembly_type` need not be specified for a particular `Assembly_definition`.

4.2.28 `Assembly_substitute_relationship`

An `Assembly_substitute_relationship` is a relationship that indicates that one `Assembly_component_relationship` (see 4.2.26) may be substituted for another `Assembly_component_relationship` (see 4.2.26). The subjects of the substitution are the related `Device` (see 4.2.88) objects of both `Assembly_component_relationship` (see 4.2.26) objects. The relating `Assembly_definition` (see 4.2.27) shall be the same in both `Assembly_component_relationship` (see 4.2.26) objects.

The data associated with an `Assembly_substitute_relationship` are the following:

— `base`;

— `description`;

— `substitute`.

4.2.28.1 `base`

The `base` specifies the `Assembly_component_relationship` (see 4.2.26) that is replaceable.

See 4.3.306 for the application assertion.

4.2.28.2 `description`

The `description` specifies additional information about the `Assembly_substitute_relationship`.

The `description` need not be specified for a particular `Assembly_substitute_relationship`.

4.2.28.3 `substitute`

ISO 10303-212:2001(E)

The substitute specifies the `Assembly_component_relationship` (see 4.2.26) that may be used instead of the base `Assembly_component_relationship` (see 4.2.26).

See 4.3.307 for the application assertion.

4.2.29 Binary_value

A `Binary_value` is a sequence of digits that may have the value 0 or 1.

NOTE `Binary_value` allows the assignment of values of data type 'binary' to data elements.

EXAMPLE An example for the use of binary values is the description of the configuration of measured-value logger boards.

The data associated with a `Binary_value` are the following:

— `value_of_binary_value`.

4.2.29.1 value_of_binary_value

The `value_of_binary_value` specifies a sequence of binary digits.

4.2.30 Body_breadth

A `Body_breadth` is the measured distance from side to side of a component in the y-axis.

The data associated with a `Body_breadth` are the following:

— `value_of_body_breadth`.

4.2.30.1 value_of_body_breadth

The `value_of_body_breadth` specifies the side to side distance value in the y-axis.

See 4.3.308 for the application assertion.

4.2.31 Body_height

A `Body_height` is the measured distance from side to side of a component in the z-axis.

The data associated with an `Body_height` are the following:

— `value_of_body_height`.

4.2.31.1 value_of_body_height

The `value_of_body_height` specifies the side to side distance value in the z-axis.

See 4.3.309 for the application assertion.

4.2.32 Body_length

A `Body_length` is the measured distance from side to side of a component in the x-axis.

The data associated with a `Body_length` are the following:

- `value_of_body_length`.

4.2.32.1 value_of_body_length

The `value_of_body_length` specifies the side to side distance value in the x-axis.

See 4.3.310 for the application assertion.

4.2.33 Cable_pull_information

A `Cable_pull_information` is a collection of facts about the installation of a cable or wire harness on a segment of its path.

NOTE Additional information can be provided by assigning `Data_element` (see 4.2.70) objects to `Cable_pull_information`.

The data associated with a `Cable_pull_information` are the following:

- `associated_object`;
- `description`;
- `id`;
- `version_id`.

4.2.33.1 associated_object

The `associated_object` specifies the equipment items to which the pulling information applies.

See 4.3.311 for the application assertion.

4.2.33.2 description

The `description` specifies an alphanumerical string containing human-interpretable text that gives further details about the `Cable_pull_information`.

The `description` need not be specified for a particular `Cable_pull_information`.

4.2.33.3 id

The `id` specifies the identifier of the `Cable_pull_information`.

4.2.33.4 version_id

The `version_id` specifies versioning information for the `Cable_pull_information`.

The `version_id` need not be specified for a particular `Cable_pull_information`.

4.2.34 Cartesian_coordinate_space_2d

A Cartesian_coordinate_space_2d is defined by two mutually perpendicular axes.

The data associated with a Cartesian_coordinate_space_2d are the following:

- length_measure_unit;
- plane_angle_measure_unit;
- precision.

4.2.34.1 length_measure_unit

The length_measure_unit specifies the increments used to define linear distances or sizes within a Cartesian_coordinate_space_2d.

4.2.34.2 plane_angle_measure_unit

The plane_angle_measure_unit specifies the increments used to define angular distances within a Cartesian_coordinate_space_2d.

4.2.34.3 precision

The precision specifies the numerical precision required for an appropriate handling of the items located in the Cartesian_coordinate_space_2d.

See 4.3.312 for the application assertion.

4.2.35 Cartesian_coordinate_space_3d

A Cartesian_coordinate_space_3d describes a three-dimensional cartesian space.

The data associated with a Cartesian_coordinate_space_3d are the following:

- length_measure_unit;
- plane_angle_measure_unit;
- precision.

4.2.35.1 length_measure_unit

The length_measure_unit specifies the increments used to define linear distances or sizes within a Cartesian_coordinate_space_3d.

4.2.35.2 plane_angle_measure_unit

The plane_angle_measure_unit specifies the increments used to define angular distances within a Cartesian_coordinate_space_3d.

4.2.35.3 precision

The precision specifies the numerical precision required for an appropriate handling of the items located in the Cartesian_coordinate_space_3d.

See 4.3.313 for the application assertion.

4.2.36 Cartesian_coordinate_space_with_grid

A Cartesian_coordinate_space_with_grid is a type of Cartesian_coordinate_space_2d (see 4.2.34) that is a framework of spaced parallel lines with a spacing delta x and delta y used to ease the positioning of any graphical item.

The data associated with a Cartesian_coordinate_space_with_grid are the following:

- delta_x;
- delta_y;
- origin.

4.2.36.1 delta_x

The delta_x specifies the spacing parallel to the x-axis.

4.2.36.2 delta_y

The delta_y specifies the spacing parallel to the y-axis.

4.2.36.3 origin

The origin specifies the positioning of the zero point of the Cartesian_coordinate_space_with_grid relative to the zero point of the Cartesian_coordinate_space_2d (see 4.2.34).

4.2.37 Cartesian_point

A Cartesian_point is a position in space defined by its coordinates in a cartesian coordinate system.

The data associated with a Cartesian_point are the following:

- coordinates.

4.2.37.1 coordinates

The coordinates specifies the position of the Cartesian_point in its coordinate space. The sequence of the coordinates in the list corresponds to the sequence of the coordinates as it is given by the mathematical definition of the coordinate system.

There shall be three or more coordinates for a Cartesian_point.

4.2.38 Certification

ISO 10303-212:2001(E)

A Certification is a certificate for an object.

The data associated with a Certification are the following:

- certification_type;
- is_applied_to;
- name;
- purpose.

4.2.38.1 certification_type

The certification_type specifies the kind of certification.

EXAMPLE 'supplier certificate' is an example for the certification_type.

4.2.38.2 is_applied_to

The is_applied_to specifies the object that the certificate is applied to.

Each is_applied_to may be one of the following: Device (see 4.2.88), Item_version (see 4.2.182), Item_version_relationship (see 4.2.183), or Supplier_solution (see 4.2.334).

See 4.3.314, 4.3.315, 4.3.316, and 4.3.317 for the application assertions.

4.2.38.3 name

The name specifies the word or group of words by which the Certification is referred to.

4.2.38.4 purpose

The purpose specifies the objective of the Certification.

The purpose need not be specified for a particular Certification.

4.2.39 Chained_dimension_pair

A Chained_dimension_pair is a type of Dimension_sequence_pair (see 4.2.97) that is the relationship between two dimensions in which the terminus of one dimension initializes the next dimension in the sequence.

4.2.40 Class_category_association

A Class_category_association is the assignment of a Specification_category (see 4.2.324) to a Product_class (see 4.2.263). Additionally, this assignment specifies if the usage of one or more Specification (see 4.2.323) objects belonging to this Specification_category (see 4.2.324) is mandatory or optional for all products of that Product_class (see 4.2.263).

NOTE 1 In the case of a strict family concept for Specification_category (see 4.2.324) objects, this Class_category_association specifies that the usage of one Specification (see 4.2.323) of this Specification_category (see 4.2.324) is mandatory for all products of that Product_class (see 4.2.263). If no strict family concept for Specification_category (see 4.2.324) objects is used, this Class_category_association specifies that the usage of one or more Specification (see 4.2.323) objects of this Specification_category (see 4.2.324) is mandatory or optional for products of that Product_class (see 4.2.263).

NOTE 2 The assignment of a Specification_category (see 4.2.324) to a Product_class (see 4.2.263) cannot replace the association of single members of the Specification_category (see 4.2.324) to the Product_class (see 4.2.263).

The data associated with an Class_category_association are the following:

- associated_category;
- associated_product_class;
- mandatory.

4.2.40.1 associated_category

The associated_category specifies the Specification_category (see 4.2.324) that is associated with the Product_class (see 4.2.263).

See 4.3.319 for the application assertion.

4.2.40.2 associated_product_class

The associated_product_class specifies the Product_class (see 4.2.263) for which the Specification_category (see 4.2.324) is valid.

See 4.3.318 for the application assertion.

4.2.40.3 mandatory

The mandatory specifies whether or not one or more Specification (see 4.2.323) objects have to be used for products within the referenced Product_class (see 4.2.263). Nonmandatory Specification (see 4.2.323) objects are considered to be optional.

EXAMPLE The specification category 'radio' may be associated optional to the product class of a car; the specification category 'engine' is an example for a mandatory association.

4.2.41 Class_condition_association

A Class_condition_association is the relation between a Specification_expression (see 4.2.326) and a Product_class (see 4.2.263). This relationship contains the information that a particular Specification_expression (see 4.2.326) is valid for all products of that product class.

ISO 10303-212:2001(E)

The data associated with a `Class_condition_association` are the following:

- `associated_condition`;
- `associated_product_class`;
- `condition_type`;
- `description`.

4.2.41.1 `associated_condition`

The `associated_condition` specifies the `Specification_expression` (see 4.2.326) that is assigned to the `Product_class` (see 4.2.263).

See 4.3.321 for the application assertion.

4.2.41.2 `associated_product_class`

The `associated_product_class` specifies the `Product` class for which the `Specification_expression` (see 4.2.326) is valid.

See 4.3.320 for the application assertion.

4.2.41.3 `condition_type`

The `condition_type` specifies the meaning of the association. The value is either user defined or predefined.

The predefined value of `condition_type` is one of the following:

- `design case`;
- `identification`;
- `part usage`;
- `validity`.

NOTE See 4.2.41.3.1 - 4.2.41.3.3 for the definition of each predefined value for `condition_type`.

4.2.41.3.1 `design case`

`design case`: The `Specification_expression` (see 4.2.326) specifies a condition when a given object has to be designed and verified. This value of the `condition_type` is for information only and shall not be interpreted when querying design cases or usage cases. For such a query, the value of the attribute '`configuration_type`' of `Configuration` (see 4.2.56) shall be evaluated;

NOTE This value may be used to precise when a given Functionality (see 4.2.155) or a given Product_component (see 4.2.265) has to be studied by the design department so that it provides solutions appropriate for the case specified by 'associated_condition' and 'associated_product_class'.

4.2.41.3.2 identification

identification: The Specification_expression (see 4.2.326) specifies a condition that enables one to distinguish the associated Product_class (see 4.2.263) from other Product_class (see 4.2.263) objects. For a top-level node in a hierarchy of Product_class (see 4.2.263) objects, this value is not applicable. This identification is part of the identification of all subclasses of this product class;

4.2.41.3.3 part usage

part usage: The Specification_expression (see 4.2.326) specifies a condition for the usage of the components of an Alternative_solution (see 4.2.12) in the products of the associated Product_class (see 4.2.263). In this case, the Class_condition_association shall be referenced by at least one Configuration (see 4.2.56) object;

4.2.41.3.4 validity

validity: The Specification_expression (see 4.2.326) specifies a condition that is used to verify a Product_specification (see 4.2.269) for the associated Product_class (see 4.2.263). That means that the Specification_expression (see 4.2.326) evaluates to 'true' if the set of Specification (see 4.2.323) objects is valid; otherwise it evaluates to 'false' with the meaning that the specified object is invalid for the Product_class (see 4.2.263). It is valid for all products belonging to the 'associated_product_class' in case of the condition types 'identification' and 'validity'.

4.2.41.4 description

The description specifies an alphanumerical string containing human-interpretable text that gives further details about the Class_condition_association.

The description need not be specified for a particular Class_condition_association.

4.2.42 Class_inclusion_association

A Class_inclusion_association is the assignment of a Specification_inclusion (see 4.2.327) to a Product_class (see 4.2.263). This assignment contains the information that a particular Specification_inclusion (see 4.2.327) applies for all products of that Product_class (see 4.2.263).

The data associated with a Class_inclusion_association are the following:

ISO 10303-212:2001(E)

- associated_inclusion;
- associated_product_class;
- description.

4.2.42.1 associated_inclusion

The associated_inclusion specifies the Specification_inclusion (see 4.2.327) that is associated with the Product_class (see 4.2.263).

See 4.3.323 for the application assertion.

4.2.42.2 associated_product_class

The associated_product_class specifies the Product_class (see 4.2.263) for which the Specification_inclusion (see 4.2.327) is valid.

See 4.3.322 for the application assertion.

4.2.42.3 description

The description specifies an alphanumeric string containing human-interpretable text that gives further details about the Class_inclusion_association.

The description need not be specified for a particular Class_inclusion_association.

4.2.43 Class_reference

A Class_reference specifies the information that is required to retrieve a General_classification (see 4.2.156) object from a library compliant to ISO 13584-42.

NOTE 1 The library shall be compliant to the type referred within the 'type_of_repository' attribute.

NOTE 2 The library is not necessarily available in computer interpretable form.

EXAMPLE 1 A library available in paper form.

The data associated with a Class_reference are the following:

- code;
- supplier;
- type_of_repository;
- version.

4.2.43.1 code

The code specifies an identifier for the General_classification (see 4.2.156) object within the repository. The format of this code is defined in ISO 13584-42.

NOTE 3 The repository referred within the 'type_of_repository' attribute may impose further restrictions on the content of this attribute.

4.2.43.2 supplier

The supplier specifies the source of the repository. The format of this specification is defined in ISO 13584-26.

NOTE 4 The repository referred within the 'type_of_repository' attribute may impose further restrictions on the content of this attribute.

4.2.43.3 type_of_repository

The type_of_repository specifies the kind of repository. The content of the attributes of Class_reference and, if present, the associated Property_reference (see 4.2.275) object shall follow the syntax specified by type_of_repository. The value is either user defined or predefined.

NOTE 5 In case when the attribute value is user defined the library shall still conform to ISO 13584.

EXAMPLE A company specific library 'RETSUA' that conforms to ISO 13584.

The predefined value of type_of_repository is one of the following:

- iec 61360 library;
- iso 13584 library.

NOTE See 4.2.43.3.1 - 4.2.43.3.2 for the definition of each predefined value for type_of_repository.

4.2.43.3.1 iec 61360 library

iec 61360 library: The repository shall conform to IEC 61360.

NOTE 6 Libraries that conform to IEC 61360 add further restrictions to ISO 13584.

4.2.43.3.2 iso 13584 library

ISO 10303-212:2001(E)

iso 13584 library: The repository shall conform to ISO 13584.

4.2.43.1 version

The version specifies the variant of the entry in the repository.

NOTE 7 The repository referred within the 'type_of_repository' attribute may impose certain restrictions on the content of this attribute.

4.2.44 Class_specification_association

A Class_specification_association is the relation between a Specification (see 4.2.323) and a Product_class (see 4.2.263). This Specification (see 4.2.323) serves as a potential characteristic of all products belonging to the product class.

The data associated with a Class_specification_association are the following:

- associated_product_class;
- associated_specification;
- association_type.

4.2.44.1 associated_product_class

The associated_product_class specifies the Product_class (see 4.2.263) for which the Specification (see 4.2.323) is valid.

See 4.3.324 for the application assertion.

4.2.44.2 associated_specification

The associated_specification specifies the Specification (see 4.2.323) that is associated with the Product_class (see 4.2.263).

See 4.3.325 for the application assertion.

4.2.44.3 association_type

The association_type specifies the kind of availability of a particular Specification (see 4.2.323) in a Product_class (see 4.2.263). The value is either user defined or predefined.

The predefined value of `association_type` is one of the following:

- availability;
- identification;
- non replaceable standard;
- part usage;
- option;
- replaceable standard.

NOTE See 4.2.44.3.1 - 4.2.44.3.5 for the definition of each predefined value for `association_type`.

4.2.44.3.1 availability

availability: The Specification (see 4.2.323) is a potential characteristic of any product belonging to a high-level Product class. It is not specified if this is an option or a standard.

4.2.44.3.2 identification

identification: The Specification (see 4.2.323) is the characteristic that enables to distinguish the associated Product_class (see 4.2.263) from other Product_class (see 4.2.263) objects. This is a kind of 'non replaceable standard'. For a top-level node in a hierarchy of Product_class (see 4.2.263) objects this value shall not be applied. This identification is part of the identification of all subclasses of this Product_class (see 4.2.263).

4.2.44.3.3 non replaceable standard

non replaceable standard: The Specification (see 4.2.323) is a characteristic of any product belonging to the product class.

EXAMPLE The specification 'South East Asia climate zone' is a 'non replaceable standard' for a system with market context 'Japan'.

4.2.44.3.4 part usage

part usage: The Specification (see 4.2.323) is a characteristic for the usage of the components of an Alternative_solution (see 4.2.12) or the usage of an Device (see 4.2.88) in the products of the associated Product_class (see 4.2.263).

4.2.44.3.5 option

option: The Specification (see 4.2.323) is a characteristic of a product if explicitly chosen. The Specification (see 4.2.323) replaces another Specification (see 4.2.323) of the same specification category if the replaced Specification (see 4.2.323) is associated with the Product class as 'replaceable standard'.

4.2.44.3.6 replaceable standard

replaceable standard: The Specification (see 4.2.323) is a default characteristic of the products belonging to the Product_class (see 4.2.263) as long as no other specification of the same specification category is chosen;

4.2.45 Class_structure_relationship

A Class_structure_relationship is the mechanism to state that the related application object is a means for fulfilling partially or fully the requirements of the relating Product_class (see 4.2.263) or that the related application object is an element of the functional structure of the relating Product_class (see 4.2.263).

The data associated with a Class_structure_relationship are the following:

- description;
- related;
- relating;
- relation type.

4.2.45.1 description

The description specifies additional information about the Class_structure_relationship.

The description need not be specified for a particular Class_structure_relationship.

4.2.45.2 related

The related specifies the Product_component (see 4.2.265) or Single_function_unit (see 4.2.315) object related by the Class_structure_relationship.

Each related may be one of the following: Function_definition (see 4.2.145) or Product_component (see 4.2.265).

See 4.3.326 and 4.3.328 for the application assertions.

4.2.45.3 relating

The relating specifies the Product_class (see 4.2.263) object related by the Class_structure_relationship.

See 4.3.327 for the application assertion.

4.2.45.4 relation_type

The relation_type specifies the meaning of the relationship. The value is either user defined or predefined.

The predefined value of `relation_type` is one of the following:

- functionality;
- realization.

NOTE See 4.2.45.4.1 - 4.2.45.4.2 for the definition of each permissible value for `relation_type`.

4.2.45.4.1 functionality

`functionality`: The related `Single_function_unit` (see 4.2.315) is an element of the functional structure of the relating `Product_class` (see 4.2.263).

4.2.45.4.2 realization

`realization`: The related `Product_component` (see 4.2.265) is a means for fulfilling, partially or fully, the requirements identified with the relating `Product_class` (see 4.2.263).

4.2.46 Classification_association

The `Classification_association` is the relation between the classification information and the item that is to be categorized. The purpose of this relationship is specified by the content of the attribute role.

The data associated with a `Classification_association` are the following:

- classification;
- `classified_element`;
- definitional;
- role.

4.2.46.1 classification

The classification specifies the `General_classification` (see 4.2.156).

See 4.3.352 for the application assertion.

4.2.46.2 classified_element

The `classified_element` specifies the item that is categorized through the related `General_classification` (see 4.2.156).

Each `classified_element` may be one of the following: `Activity` (see 4.2.1), `Activity_method` (see 4.2.3), `Annotation_subfigure_definition` (see 4.2.18), `Approval` (see 4.2.23), `Approval_status` (see 4.2.25), `Complex_product` (see 4.2.51), `Connectivity_definition` (see 4.2.61), `Contract` (see 4.2.63), `Data_element` (see 4.2.70), `Data_element_association` (see 4.2.71), `Data_element_definition` (see 4.2.72), `Design_discipline_item_definition` (see 4.2.86), `Device` (see 4.2.88), `Document` (see 4.2.101), `Document_file` (see 4.2.106), `Document_version` (see 4.2.114), `Drawing` (see 4.2.119), `Drawing_sheet` (see 4.2.122), `Function_definition` (see 4.2.145), `Function_unit` (see 4.2.148), `Function_version` (see 4.2.150), `Functional_connectivity_definition` (see 4.2.152), `Functionality` (see 4.2.155), `Interface_port` (see 4.2.171), `Interface_terminal` (see 4.2.174), `Item` (see 4.2.178), `Item_version` (see

ISO 10303-212:2001(E)

4.2.182), Location (see 4.2.192), Path (see 4.2.232), Path_node (see 4.2.233), Port (see 4.2.247), Product_class (see 4.2.263), Product_identification (see 4.2.268), Project (see 4.2.271), Requirement (see 4.2.285), Route (see 4.2.290), Section (see 4.2.296), Section_interface (see 4.2.298), Security_level (see 4.2.302), Signal (see 4.2.309), Specification_category (see 4.2.324), Terminal (see 4.2.338), Typical_schematic_node (see 4.2.347), User_defined_symbol_definition (see 4.2.355), Work_order (see 4.2.364), or Work_request (see 4.2.365).

See 4.3.329, 4.3.330, 4.3.331, 4.3.332, 4.3.333, 4.3.334, 4.3.335, 4.3.336, 4.3.337, 4.3.338, 4.3.339, 4.3.340, 4.3.341, 4.3.342, 4.3.343, 4.3.344, 4.3.345, 4.3.346, 4.3.347, 4.3.348, 4.3.349, 4.3.350, 4.3.351, 4.3.353, 4.3.354, 4.3.355, 4.3.356, 4.3.357, 4.3.358, 4.3.359, 4.3.360, 4.3.361, 4.3.362, 4.3.363, 4.3.364, 4.3.365, 4.3.366, 4.3.367, 4.3.368, 4.3.369, 4.3.370, 4.3.371, 4.3.372, 4.3.373, 4.3.374, and 4.3.375 for the application assertions.

4.2.46.3 definitional

The definitional specifies whether or not the General_classification (see 4.2.156) acts as an identifying characteristic of the item assigned by associated_classification.

NOTE If definitional is 'true', the General_classification (see 4.2.156) serves as an identification criterion for the associated item.

4.2.46.4 role

The role specifies the purpose of the General_classification (see 4.2.156). The value is either user defined or predefined.

The role need not be specified for a particular Classification_association. The role need not be specified for a particular Classification_association.

The predefined value of role is one of the following:

- electromagnetic compatibility;
- environmental conditions;
- flow direction;
- protection class.

NOTE See 4.2.46.4.1 - 4.2.46.4.4 for the definition of each predefined value for role.

4.2.46.4.1 electromagnetic compatibility

electromagnetic compatibility: The associated_classification is the classification that categorizes the classified element in respect of its ability to comply with requirements concerning electromagnetic interference.

4.2.46.4.2 environmental conditions

environmental conditions: The `associated_classification` is the classification that categorizes the classified element in respect of its ability to comply with requirements concerning its environmental surroundings.

NOTE Environmental conditions are classified in accordance to classification systems such as IEC 60721. Nonclassified data, such as the precise value of temperature, may be specified by using a `Data_element` (see 4.2.70).

4.2.46.4.3 flow direction

flow direction: The `associated_classification` is the classification that categorizes the classified element with respect to the flow of matter, energy, or information.

EXAMPLE 1 The assigned classification may give information whether the element acts as an input port, an output port, or a bi-directional port, etc.

4.2.46.4.4 protection class

protection class: The `associated_classification` is the classification that categorizes the classified element in respect of its ability to withstand environmental conditions. The protection of the environment from potentially hazardous circumstances within a piece of equipment can be also addressed by this classification.

EXAMPLE 2 Protection from electrical shock, vibration, humidity, etc.

EXAMPLE 3 IEC 60529 specifies a classification for the degree of protection provided by enclosures.

NOTE To specify the protection class that is requested in a specific environment a Requirement (see 4.2.285) may be associated to the classified element.

4.2.47 Classification_attribute

A `Classification_attribute` is a characteristic used to classify an item associated with the corresponding `General_classification` (see 4.2.156).

ISO 10303-212:2001(E)

The data associated with a Classification_attribute are the following:

- allowed_value;
- associated_classification;
- attribute_definition;
- description;
- id;
- name.

4.2.47.1 allowed_value

The allowed_value specifies the set of Data_element (see 4.2.70) objects that represent characteristic values of the Classification_attribute.

See 4.3.376 for the application assertion.

4.2.47.2 associated_classification

The associated_classification specifies the General_classification (see 4.2.156) the Classification_attribute is a characteristic of.

See 4.3.378 for the application assertion.

4.2.47.3 attribute_definition

The attribute_definition specifies the Data_element_definition (see 4.2.72) that characterizes the allowed values.

NOTE The specification of compound characteristics can be realized by using Data_element_relationship (see 4.2.74) with relation_type 'peer' or 'decomposition'.

See 4.3.377 for the application assertion.

4.2.47.4 description

The description specifies an alphanumerical string containing human-interpretable text that gives further details about the Classification_attribute.

The description need not be specified for a particular Classification_attribute.

4.2.47.5 id

The id specifies the identifier of the Classification_attribute.

EXAMPLE The names 'a' or 'b' for length or width attributes or 'r' for radius attributes are examples for identifiers of Classification_attribute objects. The meaning of such ids is usually specified in external sources.

4.2.47.6 name

The name specifies a speaking designation of the Classification_attribute.

The name need not be specified for a particular Classification_attribute.

4.2.48 Classification_system

A Classification_system is the scheme used to define the categorization of an item.

The data associated with a Classification_system are the following:

- description;
- id.

4.2.48.1 description

The description specifies an alphanumeric string containing human-interpretable text that gives further details about the Classification_system.

The description need not be specified for a particular Classification_system.

4.2.48.2 id

The id specifies the identifier of the Classification_system.

4.2.49 Coded_size

A Coded_size is a type of Rectangular_size (see 4.2.282) that is the specification of the paper size of a sheet in an abbreviated form.

EXAMPLE Examples for Coded_size information are 'A4' or 'B5'.

The data associated with a Coded_size are the following:

- size;
- referenced_standard.

4.2.49.1 size

The size specifies the information for the drawing sheet limits.

ISO 10303-212:2001(E)

NOTE If the largeness differs from the dimensions specified by the Rectangular_area (see 4.2.281) object, which is associated through Rectangular_size (see 4.2.282), the dimensions specified through Rectangular_area (see 4.2.281) apply.

4.2.49.2 referenced_standard

The referenced_standard specifies the normative basis that gives information how to interpret the size information.

See 4.3.379 for the application assertion.

4.2.50 Colour

A Colour is a characteristic of visual presentation that is the defined relationship between red, green, and blue proportions.

Each Colour is either a Predefined_colour (see 4.2.251) or a User_defined_colour (see 4.2.350).

4.2.51 Complex_product

A Complex_product is an object with the capability that it can be realized by, decomposed into or specialized as Product_constituent (see 4.2.266) objects in a functional, logical, or physical way. Each Complex_product stands for a specific version. The capability of providing different views of the same Complex_product or a version thereof is not supported.

Each Complex_product is either an Alternative_solution (see 4.2.12) or a Product_component (see 4.2.265).

The data associated with a Complex_product are the following:

- id;
- version_id.

4.2.51.1 id

The id specifies the identifier of the Complex_product.

4.2.51.2 version_id

The version_id specifies the identification of a particular version of a Complex_product.

The version_id need not be specified for a particular Complex_product.

4.2.52 Complex_product_relationship

A Complex_product_relationship is a relationship between two Complex_product (see 4.2.51) objects. The Complex_product_relationship shall only be used to relate Complex_product (see 4.2.51) objects that are of the same kind.

The data associated with a `Complex_product_relationship` are the following:

- description;
- related;
- relating;
- `relation_type`.

4.2.52.1 description

The description specifies an alphanumeric string containing human-interpretable text that gives further details about the `Complex_product_relationship`.

The description need not be specified for a particular `Complex_product_relationship`.

4.2.52.2 related

The related specifies the second of the two objects related by the `Complex_product_relationship`.

NOTE The semantics of this attribute are defined by the attribute `relation_type`.

See 4.3.380 for the application assertion.

4.2.52.3 relating

The relating specifies the first of the two objects related by the `Complex_product_relationship`.

NOTE The semantics of this attribute are defined by the attribute `relation_type`.

See 4.3.381 for the application assertion.

4.2.52.4 relation_type

The `relation_type` specifies the meaning of the relationship. The value is either user defined or predefined.

The predefined value of `relation_type` is one of the following:

- derivation;
- substitution;
- version hierarchy;
- version sequence.

NOTE 1 See 4.2.52.4.1 - 4.2.52.4.4 for the definition of each predefined value for `relation_type`.

ISO 10303-212:2001(E)

4.2.52.4.1 derivation

derivation: The `Complex_product_relationship` defines a relationship where the related `Complex_product` (see 4.2.51) is derived from the relating `Complex_product` (see 4.2.51);

NOTE 2 The relationship does not imply inheritance of any kind between the application objects that are related.

4.2.52.4.2 redundancy

redundancy: The `Complex_product_relationship` defines a relationship where the related `Complex_product` (see 4.2.51) is replicated by the relating `Complex_product` (see 4.2.51).

EXAMPLE 1 To provide for a fail-safe service a `Product_component` (see 4.2.265) is replicated. If one `Product_component` (see 4.2.265) fails, the other is still in service.

4.2.52.4.3 substitution

substitution: The `Complex_product_relationship` defines a relationship where the related `Complex_product` (see 4.2.51) replaces the relating `Complex_product` (see 4.2.51).

4.2.52.4.4 version hierarchy

version hierarchy: The `Complex_product_relationship` defines a relationship where the related `Complex_product` (see 4.2.51) is a sub version of the relating `Complex_product` (see 4.2.51);

EXAMPLE 2 'version hierarchy' is used, whenever a revision of one particular version is prepared, e.g., 'version 1.1'.

4.2.52.4.5 version sequence

version sequence: The `Complex_product_relationship` defines a relationship where the relating `Complex_product` (see 4.2.51) is the preceding version and the related `Complex_product` (see 4.2.51) is the following version.

NOTE 3 The relationship does not imply inheritance of any kind between the application objects that are related.

EXAMPLE 3 'version sequence' is used, whenever a new version is prepared, e.g., 'version 1.0' is the preceding version for the following 'version 2.0'.

4.2.53 Component_colour

A `Component_colour` is the sensation produced on the eye by rays of light reflected or emitted by the body of a piece of equipment.

The data associated with a `Component_colour` are the following:

- `coding_system`;
- `colour_id`.

4.2.53.1 coding_system

The `coding_system` specifies the method that shall be applied to interpret the content of the 'colour_id' attribute.

The `coding_system` need not be specified for a particular `Component_colour`.

See 4.3.382 for the application assertion.

4.2.53.2 colour_id

The `colour_id` specifies uniquely the identity of the colour `coding_system` that is within scope of this part of ISO 10303.

4.2.54 Component_placement

A `Component_placement` is the information pertaining to the placement of a `Product_component` (see 4.2.265), which is defined in its own coordinate space, in the coordinate space of a reference `Product_component` (see 4.2.265).

EXAMPLE An example for the use of a `Component_placement` is the placement of the `Product_component` (see 4.2.265) 'motor control centre' dependent on requirements of the customer.

The data associated with a `Component_placement` are the following:

- `placed_component`;
- `transformation`;
- `reference_product_component`.

4.2.54.1 placed_component

The `placed_component` applies only to objects that are unambiguously placed in the context of the `placed_component`.

NOTE The `Component_placement` does not define a placement for all variants of the `placed_component` in the context of 'reference_product_component'.

See 4.3.383 for the application assertion.

4.2.54.2 transformation

The `transformation` specifies the placement of the `placed Product_component` (see 4.2.265).

4.2.54.3 reference_product_component

The reference_product_component specifies the high level Product_component (see 4.2.265) that is defined in the reference coordinate space.

See 4.3.384 for the application assertion.

4.2.55 Composition_relationship

A Composition_relationship is the relation that specifies that a Function_definition (see 4.2.145) consists of Function_unit (see 4.2.148) objects.

The data associated with a Composition_relationship are the following:

- composed_function;
- functional_component.

4.2.55.1 composed_function

The composed_function specifies a Function_definition (see 4.2.145) that is composed of Function_unit (see 4.2.148) objects.

See 4.3.385 for the application assertion.

4.2.55.2 functional_component

The functional_component specifies the Function_unit (see 4.2.148) that is a constituent of the Function_definition (see 4.2.145) object specified by composed_function.

See 4.3.386 for the application assertion.

4.2.56 Configuration

A Configuration is the association of a Class_condition_association (see 4.2.41) or a Class_specification_association (see 4.2.44) object with an application object in order to define a valid usage of this application object in the context of a certain Product_class (see 4.2.263). The validity of the association may be limited by effectivity information.

EXAMPLE The validity of the association may be limited by a time period through assigning an Effectivity (see 4.2.127) object to it.

NOTE The semantics of the kind of association is defined by the attributes `configuration_type` and `inheritance_type`.

The data associated with a Configuration are the following:

- `configuration_type`;
- `configured_element`;
- `inheritance_type`;
- `is_solution_for`.

4.2.56.1 `configuration_type`

The `configuration_type` specifies the valid usage of a Configuration object that is applied to the application object as configured element.

The value of `configuration_type` is one of the following:

- `design`;
- `usage`.

NOTE See 4.2.56.1.1 - 4.2.56.1.2 for the definition of each permissible value for `configuration_type`.

4.2.56.1.1 `design`

`design`: The item referenced as configured element has to be designed and checked before it can actually be used in a given context. This context is specified by the `Class_condition_association` (see 4.2.41) and `Class_specification_association` (see 4.2.44) objects referenced as the `is_solution_for`.

4.2.56.1.2 `usage`

`usage`: The item referenced as the configured element is controlled by a Configuration. The `Class_condition_association` (see 4.2.41) and `Class_specification_association` (see 4.2.44) objects specify the use cases and are referenced as the `is_solution_for`.

4.2.56.2 `configured_element`

The `configured_element` specifies the application object that is controlled for its valid usage by the Configuration.

Each `configured_element` may be one of the following: `Complex_product` (see 4.2.51), `Connectivity_definition` (see 4.2.61), `Device` (see 4.2.88), `Function_unit` (see 4.2.148), `Functional_connectivity_definition` (see 4.2.152), `Location` (see 4.2.192), or `Signal` (see 4.2.309).

See 4.3.389, 4.3.390, 4.3.391, 4.3.392, 4.3.393, 4.3.394, and 4.3.395 for the application assertions.

4.2.56.3 inheritance_type

The inheritance_type specifies whether or not an inheritance scheme for the configuration information in a hierarchical structure is applied to the application object referenced as the configured element. The levels within such a hierarchy are defined through Product_structure_-relationship (see 4.2.270) objects or the attribute 'base_element' of Alternative_solution (see 4.2.12).

The value of inheritance_type is one of the following:

- exception;
- inherited;
- local.

NOTE See 4.2.56.3.1 - 4.2.56.3.3 for the definition of each permissible value for inheritance_type.

4.2.56.3.1 exception

exception: No inheritance scheme is applicable and all required configuration information must be attached locally to the application object. The value indicates that the configuration information may be inconsistent to the structural levels above it or is on purpose contradictory to it. Therefore an inheritance scheme shall not continue beyond this point in the product structure tree.

EXAMPLE 1 A situation when the inheritance_type 'exception' is applicable is a strike or some other disturbance unaccounted for in the current planning.

4.2.56.3.2 inherited

inherited: A scheme for inheritance of configuration information applies. The complete configuration information shall be collected from the different levels in the structure by evaluation of results through AND combination of configuration information starting at the referenced configured element and OR combination for alternatives plus additional evaluation of effectivity information. The attribute value 'inherited' only applies for items for which the same value of configuration_type is defined.

EXAMPLE 2 Figure 8 shows how inheritance is applied along the tree of a product structure: The complete configuration information of a Device (see 4.2.88) can be obtained by adding any such information to Alternative_solution (see 4.2.12) objects which are linked through Solution_instance_assignment (see 4.2.318) objects and 'base_element' attributes respectively. Whenever more than one higher level instance is present, the current information available is branched in as many branches as instances are present. For example, the total configuration information for the Device (see 4.2.88) given in Figure 8 could be expressed as follows: (C0.0 AND C1.0 AND C2.0) OR (C0.0 AND C1.1 AND C2.1) OR (C0.0 AND C1.1 AND C2.2).

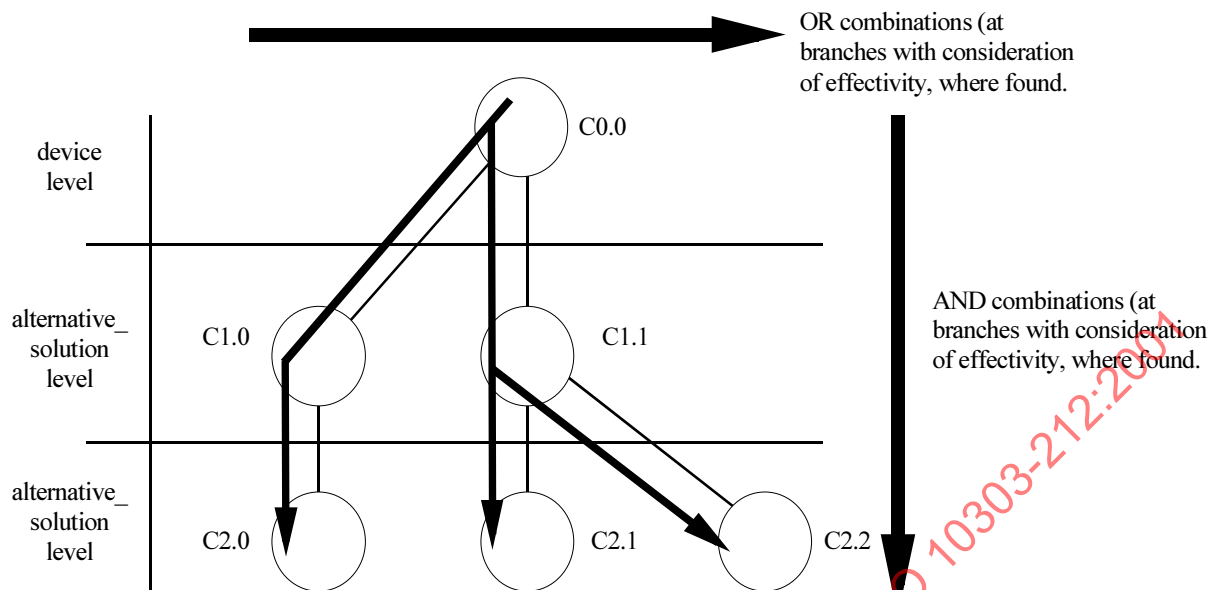

Figure 8 - Configuration inheritance scheme

4.2.56.3.3 local

local: No inheritance scheme is applicable and all required configuration information must be attached locally at the application object. Nevertheless, any potentially inherited configuration information of a higher level shall be consistent, i.e., be a subset of the locally defined configuration information;

4.2.56.4 is_solution_for

The `is_solution_for` specifies the characteristics for which the item referenced as configured element provides a solution. The characteristics are described by a `Class_specification_association` (see 4.2.44). Combinations of characteristics are defined by a `Class_condition_association` (see 4.2.41) where the 'condition_type' attribute is 'part usage'.

Each `is_solution_for` may be one of the following: `Class_condition_association` (see 4.2.41) or `Class_specification_association` (see 4.2.44).

See 4.3.387 and 4.3.388 for the application assertions.

4.2.57 Connect_area

A `Connect_area` is the specification of the zone where the schematic terminal is allowed to be connected with other terminals or connecting lines.

ISO 10303-212:2001(E)

The data associated with a `Connect_area` are the following:

— `defined_by`.

4.2.57.1 `defined_by`

The `defined_by` specifies the borders of an area or a point that defines a zone where the schematic terminal is allowed to be connected with other terminals or connecting lines. That zone is sometimes addressed as the 'hot spot' of the connect node.

Each `defined_by` may be one of the following: `Curve_2d` (see 4.2.66) or `Point_2d` (see 4.2.245).

See 4.3.396 and 4.3.397 for the application assertions.

4.2.58 `Connecting_line`

A `Connecting_line` is the representation of a `Connection` (see 4.2.59) in a schematic diagram. It shall be used to present connectivity.

The data associated with a `Connecting_line` are the following:

— `presents`.

4.2.58.1 `presents`

The `presents` specifies the connectivity items the `Connecting_line` is displaying.

Each `presents` may be one of the following: `Connectivity_definition` (see 4.2.61) or `Functional_connectivity_definition` (see 4.2.152).

See 4.3.398 and 4.3.399 for the application assertions.

4.2.59 `Connection`

A `Connection` is a type of `Connectivity_definition` (see 4.2.61) that is a link between `Terminal` (see 4.2.338) objects with the intention to allow the flow of information, energy, or matter. `Connection` objects may be used to divide a network in portions that can be implemented by using a specified equipment.

NOTE 1 The connections represent the information that is normally given in connection tables.

NOTE 2 The internal structure of connection bundles can be specified by decomposing a Connection into its constituting Connection objects by assigning Connectivity_definition_-relationship (see 4.2.62) objects of relation_type 'decomposition'.

EXAMPLE 1 Implementing a network by using busbars may require another subdivision into Connection objects as if the network is to be implemented with cables.

EXAMPLE 2 In Figure 9 a cable is shown. Each pin of the cable is defined as a Terminal (see 4.2.338), and each wire in the cable is defined as a Connection. In this figure the five Connection objects are grouped. Connection 3 decomposes into Connection objects 1 and 2. Connection 1 decomposes into three Connection objects, Connection 2 consists of two Connection objects.

The data associated with a connection are the following:

— connected_terminal.

4.2.59.1 connected_terminal

The connected_terminal specifies the terminals interconnected by the Connection.

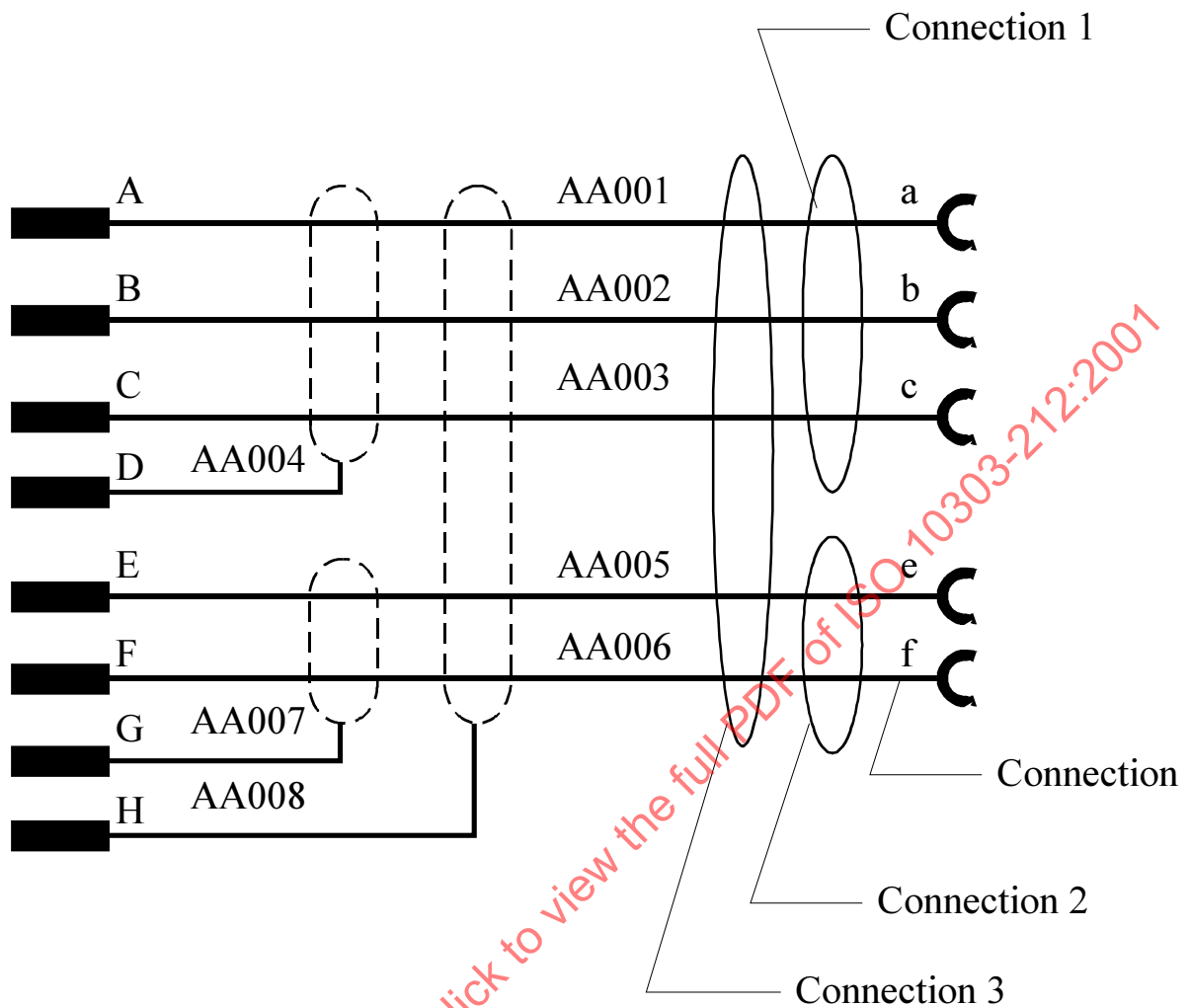

Figure 9 - Decomposition of Connection objects

See 4.3.400 for the application assertion.

4.2.60 Connectivity_allocation

A Connectivity_allocation is the relation that specifies the item selected to implement the specified Functional_connectivity_definition (see 4.2.152).

The data associated with a Connectivity_allocation are the following:

- allocated_connectivity_definition;
- connectivity_implementation;
- description.

4.2.60.1 allocated_connectivity_definition

The allocated_connectivity_definition specifies Functional_connectivity_definition (see 4.2.152) objects or Device (see 4.2.88) objects that are assigned by the Connectivity_allocation to Connectivity_definition (see 4.2.61) objects.

See 4.3.404 for the application assertion.

4.2.60.2 connectivity_implementation

The connectivity_implementation specifies Connectivity_definition (see 4.2.61) elements that are assigned to Functional_connectivity_definition (see 4.2.152) elements or Device (see 4.2.88) objects.

Each connectivity_implementation may be one of the following: Connectivity_definition (see 4.2.61), Device (see 4.2.88), Function_unit (see 4.2.148), or Physical_instance (see 4.2.243).

See 4.3.401, 4.3.402, 4.3.403, and 4.3.405 for the application assertions.

4.2.60.3 description

The description specifies an alphanumerical string containing human-interpretable text that gives further details about the Connectivity_allocation.

The description need not be specified for a particular Connectivity_allocation.

4.2.61 Connectivity_definition

A Connectivity_definition is the specification of the ability to enable a flow of information, energy, or material within a piece of equipment.

Each Connectivity_definition is either a Connection (see 4.2.59) or an Interface_terminal_connection (see 4.2.175).

ISO 10303-212:2001(E)

The data associated with a Connectivity_definition are the following:

- connectivity_of;
- description;
- id;
- implemented_by;
- version_id.

4.2.61.4 connectivity_of

The connectivity_of specifies the Assembly_definition (see 4.2.27) object whose internal connectivity is specified by the Connectivity_definition.

See 4.3.406 for the application assertion.

4.2.61.5 description

The description specifies an alphanumeric string containing human-interpretable text that gives further details about the Connectivity_definition.

The description need not be specified for a particular Connectivity_definition.

4.2.61.6 id

The id specifies the identifier of the Connectivity_definition.

4.2.61.7 implemented_by

The implemented_by specifies the Device (see 4.2.88) objects that are used to accomplish the connectivity specified by Connectivity_definition.

Each implemented_by may be one of the following: Device (see 4.2.88) or Physical_instance (see 4.2.243).

See 4.3.407 and 4.3.408 for the application assertions.

4.2.61.8 version_id

The version_id specifies versioning information for the Connectivity_definition.

The version_id need not be specified for a particular Connectivity_definition.

4.2.62 Connectivity_definition_relationship

A Connectivity_definition_relationship is the relation between two Connectivity_definition (see 4.2.61) objects.

The data associated with an `Connectivity_definition_relationship` are the following:

- `description`;
- `related`;
- `relating`;
- `relation_type`.

4.2.62.1 description

The `description` specifies an alphanumeric string containing human-interpretable text that gives further details about the `Connectivity_definition_relationship`.

The `description` need not be specified for a particular `Connectivity_definition_relationship`.

4.2.62.2 related

The `related` specifies the second of the two `Connectivity_definition` (see 4.2.61) objects related by the `Connectivity_definition_relationship`.

See 4.3.409 for the application assertion.

4.2.62.3 relating

The `relating` specifies the first of the two `Connectivity_definition` (see 4.2.61) objects related by the `Connectivity_definition_relationship`.

See 4.3.410 for the application assertion.

4.2.62.4 relation_type

The `relation_type` specifies the meaning of the relationship. The value is either user defined or predefined.

ISO 10303-212:2001(E)

The predefined value of `relation_type` is one of the following:

- alternate;
- decomposition;
- derivation;
- redundancy;
- substitution;
- version hierarchy;
- version sequence.

NOTE 1 See 4.2.62.4.1 - 4.2.62.4.7 for the definition of each predefined value for `relation_type`.

4.2.62.4.1 alternate

alternate: The `Connectivity_definition_relationship` defines a relationship where the related `Connectivity_definition` (see 4.2.61) is a possible substitute to the relating `Connectivity_definition` (see 4.2.61).

NOTE 2 This concept refers to the possibility to replace the related `Connectivity_definition` (see 4.2.61). The actual replacement is addressed by 'substitution'.

4.2.62.4.2 decomposition

decomposition: The `Connectivity_definition_relationship` defines a relationship where the related `Connectivity_definition` (see 4.2.61) is one of the components into which the relating `Connectivity_definition` (see 4.2.61) is divided up.

4.2.62.4.3 derivation

derivation: The `Connectivity_definition_relationship` defines a deriving relationship where the related `Connectivity_definition` (see 4.2.61) is based on the relating `Connectivity_definition` (see 4.2.61).

4.2.62.4.4 redundancy

redundancy: The `Connectivity_definition_relationship` defines a relationship where the related `Connectivity_definition` (see 4.2.61) is replicated by the relating `Connectivity_definition` (see 4.2.61).

EXAMPLE To provide for a fail-safe link two connections are used to provide for the connectivity. If one connection fails, then the other is still in service.

4.2.62.4.5 substitution

substitution: The `Connectivity_definition_relationship` defines a relationship where the related `Connectivity_definition` (see 4.2.61) replaces the relating `Connectivity_definition` (see 4.2.61).

4.2.62.4.6 version hierarchy

version hierarchy: The `Connectivity_definition_relationship` defines a hierarchical relationship where the related `Connectivity_definition` (see 4.2.61) is a subversion of the relating `Connectivity_definition` (see 4.2.61).

EXAMPLE Revisions 1.1 and 1.2 of a `Connectivity_definition` (see 4.2.61).

4.2.62.4.7 version sequence

version sequence: The `Connectivity_definition_relationship` defines a succession of versions where the relating `Connectivity_definition` (see 4.2.61) is the preceding version, and the related `Connectivity_definition` (see 4.2.61) is the following version.

4.2.63 Contract

A Contract is the binding agreement that specifies the connection between the assigned parties.

The data associated with a Contract are the following:

- `contracted_element`;
- `description`;
- `id`.

4.2.63.1 contracted_element

The `contracted_element` specifies the work that is the subject of the Contract.

Each `contracted_element` may be one of the following: `Activity` (see 4.2.1), `Data_element` (see 4.2.70), `Design_discipline_item_definition` (see 4.2.86), `Device` (see 4.2.88), `Function_definition` (see 4.2.145), `Function_unit` (see 4.2.148), `Function_version` (see 4.2.150), `Item_version` (see 4.2.182), `Location` (see 4.2.192), `Node` (see 4.2.208), `Notification` (see 4.2.213), `Path` (see 4.2.232), `Path_node` (see 4.2.233), `Physical_instance` (see 4.2.243), `Process_variable` (see 4.2.260), `Project` (see 4.2.271), `Route` (see 4.2.290), `Section` (see 4.2.296), `Section_end` (see 4.2.297), `Section_interface` (see 4.2.298), `Signal` (see 4.2.309), `Signal_value` (see 4.2.313), `Technical_system` (see 4.2.336), `Work_order` (see 4.2.364), or `Work_request` (see 4.2.365).

See 4.3.411, 4.3.412, 4.3.413, 4.3.414, 4.3.415, 4.3.416, 4.3.417, 4.3.418, 4.3.419, 4.3.420, 4.3.421, 4.3.422, 4.3.423, 4.3.424, 4.3.425, 4.3.426, 4.3.427, 4.3.428, 4.3.429, 4.3.430, 4.3.431, 4.3.432, 4.3.433, 4.3.434, and 4.3.435 for the application assertions.

4.2.63.2 description

The `description` specifies an alphanumerical string containing human-interpretable text that gives further details about the Contract.

The `description` need not be specified for a particular Contract.

4.2.63.3 id

The `id` specifies the identifier of the Contract.

4.2.64 Cross_reference

A Cross_reference is an element that provides the reference from one part of a document to another.

Each Cross_reference is either a Detached_representation_reference (see 4.2.87), a Note_reference (see 4.2.212), or a Page_connector_reference (see 4.2.229).

4.2.65 Cross_section

A Cross_section is the transverse section of a solid.

The data associated with a Cross_section are the following:

— value_of_cross_section.

4.2.65.1 value_of_cross_section

The value_of_cross_section specifies the numerical value that represents the extent of the cross section.

See 4.3.436 for the application assertion.

4.2.66 Curve_2d

A Curve_2d is the path of a point moving in a two-dimensional coordinate space.

4.2.67 Curve_3d

A Curve_3d is the path of a point moving in a three-dimensional coordinate space.

4.2.68 Curve_appearance

A Curve_appearance is a type of Appearance (see 4.2.21) that governs the visual presentation of geometric curves and annotation curves.

The data associated with a Curve_appearance are the following:

- corner_styles;
- curve_colour;
- curve_ends;
- draughting_role;
- font;
- width.

4.2.68.1 corner_styles

The corner_styles specifies whether the appearance of an Annotation_curve (see 4.2.14) is squared or rounded at its corners.

The value of corner_styles is one of the following:

- round;
- square.

NOTE See 4.2.68.1.1 - 4.2.68.1.2 for the definition of each permissible value for relation_type.

4.2.68.1.1 round

round: The graphical presentation of a corner with corner_style round is shown in Figure 10.

4.2.68.1.2 square

square: The graphical presentation of a corner in a line with corner_style square is shown in Figure 10.



Figure 10 - Predefined corner styles

The corner_styles need not be specified for a particular Curve_appearance.

4.2.68.2 curve_colour

The curve_colour specifies the colour to be used for the presentation of a curve.

See 4.3.437 for the application assertion.

4.2.68.3 curve_ends

The curve_ends specifies whether the appearance of an Annotation_curve (see 4.2.14) is squared or rounded at its ends.

The value of curve_ends is one of the following:

- round;
- square.

NOTE See 4.2.68.3.1 - 4.2.68.3.2 for the definition of each permissible value for curve_ends.

4.2.68.3.1 round

round: The graphical presentation of a line with curve_ends of type round is shown in Figure 11.

4.2.68.3.2 square

square: The graphical presentation of a line with curve_ends of type square is shown in Figure 11.



Figure 11 - Predefined curve end styles

The curve_ends need not be specified for a particular Curve_appearance.

4.2.68.4 draughting_role

The draughting_role specifies the purpose within a draughting for a particular curve appearance.

EXAMPLE A draughting_role could be a centreline or section line.

The draughting_role need not be specified for a particular Curve_appearance.

4.2.68.5 font

The font describes the style to be applied on the presentation of a curve.

See 4.3.438 for the application assertion.

4.2.68.6 width

The width specifies the thickness of the curve measured perpendicular to the direction of the curve.

4.2.69 Curve_dimension

A Curve_dimension is a type of Dimension (see 4.2.93) that is the graphical presentation of the value of the distance between two elements, measured along a curved path or the length of a curved element.

The data associated with a Curve_dimension are the following:

- component;
- extent.

4.2.69.1 component

The component specifies the projection lines that shows the extension of the points, lines, or surfaces that bound the measurement.

See 4.3.440 for the application assertion.

4.2.69.2 extent

The extent specifies the dimension line that graphically presents where the dimension value applies.

ISO 10303-212:2001(E)

See 4.3.439 for the application assertion.

4.2.70 Data_element

A Data_element is a technical or administrative property that may be used to characterize items or relationships between items. Data_element objects allow one to associate technical or administrative data to the product data.

NOTE 1 Data associated to distinct life cycle stages shall be associated to application objects that are related to Function_definition (see 4.2.145), Design_discipline_item_definition (see 4.2.86), or Product_component (see 4.2.265) objects with the appropriate Application_context (see 4.2.22) object assigned.

Each Data_element is either a Predefined_data_element (see 4.2.253) or a User_defined_data_element (see 4.2.351).

The data associated with a Data_element are the following:

- description;
- global_unit;
- qualifier;
- value_determination.

4.2.70.1 description

The description specifies an alphanumerical string containing human-interpretable text that gives further details about the Data_element.

The description need not be specified for a particular Data_element.

4.2.70.2 global_unit

The global_unit specifies a unit that is valid for all Value_with_unit (see 4.2.360) objects that are referenced by the Data_element.

The global_unit need not be specified for a particular Data_element.

4.2.70.3 qualifier

The qualifier specifies the interpretation of the value assigned to Data_element.

NOTE 2 The value is assigned through the 'value_of_data_element' attribute of User_defined_data_element (see 4.2.351) or by the 'data' attribute of Predefined_data_element (see 4.2.253).

The value of qualifier is one of the following:

- nominal;
- specified;
- typical.

NOTE 3 See 4.2.70.3.1 - 4.2.70.3.3 for the definition of each permissible value for qualifier.

4.2.70.3.1 nominal

nominal: The value assigned to Data_element represents a suitable approximate quantity value used to designate the assigned item.

4.2.70.3.2 specified

specified: The value assigned to Data_element represents the value as it is included in the specification. The actual value may differ from the specified value.

4.2.70.3.3 typical

typical: The value assigned to Data_element represents a value that is characteristic for that specific attribute under the circumstances the attribute is used.

The qualifier need not be specified for a particular Data_element.

4.2.70.4 value_determination

The value_determination specifies the kind of data given by Data_element. The value is either user defined or predefined.

The value_determination need not be specified for a particular Data_element. The value_determination need not be specified for a particular Data_element.

ISO 10303-212:2001(E)

The predefined value of value_determination is one of the following:

- calculated;
- designed;
- estimated;
- measured;
- required;
- setpoint.

NOTE 4 See 4.2.70.4.1 - 4.2.70.4.6 for the definition of each predefined value for value_determination.

4.2.70.4.1 **calculated**

calculated: The value has been calculated from a particular representation.

4.2.70.4.2 **designed**

designed: The value represents the value intended by the design.

4.2.70.4.3 **estimated**

estimated: The value has been estimated.

4.2.70.4.4 **measured**

measured: The value has been measured.

4.2.70.4.5 **required**

required: The value represents the requirement.

4.2.70.4.6 **setpoint**

setpoint: The value represents the quantity that is to be used as specified value.

4.2.71 **Data_element_association**

A Data_element_association is the assignment of a Data_element (see 4.2.70) to an item.

The data associated with a Data_element_association are the following:

- associated_data_element;
- associated_item;
- definitional;
- description;
- data_element_context.

4.2.71.1 associated_data_element

The associated_data_element specifies the Data_element (see 4.2.70) that is assigned to an item.

See 4.3.450 for the application assertion.

4.2.71.2 associated_item

The associated_item specifies the item that is described by the associated Data_element (see 4.2.70).

Each associated_item may be one of the following: Activity (see 4.2.1), Assembly_component_relationship (see 4.2.26), Cable_pull_information (see 4.2.33), Complex_product (see 4.2.51), Complex_product_relationship (see 4.2.52), Composition_relationship (see 4.2.55), Connectivity_allocation (see 4.2.60), Connectivity_definition (see 4.2.61), Connectivity_definition_relationship (see 4.2.62), Design_discipline_item_definition (see 4.2.86), Device (see 4.2.88), Device_relationship (see 4.2.89), Document (see 4.2.101), Document_file (see 4.2.106), Document_representation (see 4.2.110), Document_version (see 4.2.114), Drawing_sheet (see 4.2.122), Free_segment (see 4.2.144), Function_definition (see 4.2.145), Function_definition_relationship (see 4.2.146), Function_interface (see 4.2.147), Function_unit (see 4.2.148), Function_unit_relationship (see 4.2.149), Function_version (see 4.2.150), Functional_connectivity_definition (see 4.2.152), Functional_connectivity_definition_relationship (see 4.2.153), Functional_unit_allocation (see 4.2.154), Functionality (see 4.2.155), Generic_note (see 4.2.159), Interface (see 4.2.170), Interface_port (see 4.2.171), Interface_terminal (see 4.2.174), Item (see 4.2.178), Item_definition_relationship (see 4.2.179), Item_version (see 4.2.182), Location (see 4.2.192), Location_relationship (see 4.2.194), Marking (see 4.2.199), Node (see 4.2.208), Node_relationship (see 4.2.209), Notification (see 4.2.213), Offered_function_allocation (see 4.2.220), Path (see 4.2.232), Path_node (see 4.2.233), Physical_assembly_relationship (see 4.2.241), Physical_instance (see 4.2.243), Port (see 4.2.247), Port_allocation (see 4.2.248), Port_association (see 4.2.249), Preferred_item_allocation (see 4.2.258), Preferred_item_terminal_allocation (see 4.2.259), Process_variable (see 4.2.260), Product_class (see 4.2.263), Product_identification (see 4.2.268), Product_structure_relationship (see 4.2.270), Requirement (see 4.2.285), Route (see 4.2.290), Route_relationship (see 4.2.291), Routed_segment (see 4.2.293), Section (see 4.2.296), Section_end (see 4.2.297), Section_interface (see 4.2.298), Section_interface_relationship (see 4.2.299), Section_relationship (see 4.2.300), Signal (see 4.2.309), Signal_value (see 4.2.313), Technical_system (see 4.2.336), Technical_system_relationship (see 4.2.337), Terminal (see 4.2.338), or Work_order (see 4.2.364).

See 4.3.441, 4.3.442, 4.3.443, 4.3.444, 4.3.445, 4.3.446, 4.3.447, 4.3.448, 4.3.449, 4.3.451, 4.3.452, 4.3.453, 4.3.454, 4.3.455, 4.3.456, 4.3.457, 4.3.458, 4.3.459, 4.3.460, 4.3.461, 4.3.462, 4.3.463, 4.3.464, 4.3.465, 4.3.466, 4.3.467, 4.3.468, 4.3.469, 4.3.470, 4.3.471, 4.3.472, 4.3.473, 4.3.474, 4.3.475, 4.3.476, 4.3.477, 4.3.478, 4.3.479, 4.3.480, 4.3.481, 4.3.482, 4.3.483, 4.3.485, 4.3.486,

ISO 10303-212:2001(E)

4.3.487, 4.3.488, 4.3.489, 4.3.490, 4.3.491, 4.3.492, 4.3.493, 4.3.494, 4.3.495, 4.3.497, 4.3.498, 4.3.499, 4.3.500, 4.3.501, 4.3.502, 4.3.503, 4.3.504, 4.3.505, 4.3.506, 4.3.507, 4.3.508, 4.3.509, 4.3.510, 4.3.512, 4.3.513, and 4.3.514 for the application assertions.

4.2.71.3 definitional

The definitional specifies whether or not the associated Data_element (see 4.2.70) acts as an identifying characteristic of the item assigned by associated_item.

4.2.71.4 description

The description specifies an alphanumeric string containing human-interpretable text that gives further details about the Data_element_association.

The description need not be specified for a particular Data_element_association.

4.2.71.5 data_element_context

The data_element_context specifies an environment for which the Data_element_association is valid.

The data_element_context need not be specified for a particular Data_element_association.

Each data_element_context may be one of the following: Organization (see 4.2.223), Product_class (see 4.2.263), or Technical_system (see 4.2.336).

See 4.3.484, 4.3.496, and 4.3.511 for the application assertions.

4.2.72 Data_element_definition

A Data_element_definition is the composition of the information that specifies the meaning of the Data_element (see 4.2.70).

The data associated with an Data_element_definition are the following:

- admitted_qualifier;
- allowed_unit;
- description;
- id;
- source;
- version_id.

4.2.72.1 admitted_qualifier

The admitted_qualifier specifies the permitted level that the data element which is associated to the Data_element_definition may possess.

NOTE 1 If present, only the levels specified by the 'admitted_qualifier' attribute may occur in the corresponding Data_element (see 4.2.70) object.

The value of admitted_qualifier is one of the following:

- nominal;
- specified;
- typical.

NOTE 2 See 4.2.72.1.1 - 4.2.72.1.5 for the definition of each permissible value for admitted_qualifier.

4.2.72.1.1 nominal

nominal: The associated value represents a suitable approximate quantity used to designate an item.

4.2.72.1.2 specified

specified: The associated value represents the value as it is included in the specification. The actual value may differ from the specified value.

4.2.72.1.3 typical

typical: The associated value represents the value that is characteristic for that specific attribute under the circumstances the attribute is used.

4.2.72.2 allowed_unit

The allowed_unit specifies the units the data element which is associated to the Data_element_definition may possess.

NOTE If present, only the units specified by the 'allowed_unit' attribute may occur in the corresponding Data_element (see 4.2.70) object.

There shall be zero, one or more allowed_unit for a Data_element_definition.

4.2.72.3 description

The description specifies an alphanumerical string containing human-interpretable text that gives further details about the Data_element_definition.

The description need not be specified for a particular Data_element_definition.

4.2.72.4 id

The id specifies the identifier of the Data_element_definition.

4.2.72.5 source

The source specifies the query information to retrieve the Data_element_definition from a repository.

ISO 10303-212:2001(E)

The source need not be specified for a particular Data_element_definition.

Each source may be one of the following: External_library_reference (see 4.2.132) or Property_reference (see 4.2.275).

See 4.3.515 and 4.3.516 for the application assertions.

4.2.72.6 version_id

The version_id specifies versioning information for the Data_element_definition.

The version_id need not be specified for a particular Data_element_definition.

4.2.73 Data_element_definition_relationship

A Data_element_definition_relationship is the relation between two Data_element_definition (see 4.2.72) objects.

The data associated with an Data_element_definition_relationship are the following:

- description;
- related;
- relating;
- relation_type.

4.2.73.1 description

The description specifies an alphanumeric string containing human-interpretable text that gives further details about the Data_element_definition_relationship.

The description need not be specified for a particular Data_element_definition_relationship.

4.2.73.2 related

The related specifies the second of the two Data_element_definition (see 4.2.72) objects related by the Data_element_definition_relationship.

See 4.3.517 for the application assertion.

4.2.73.3 relating

The relating specifies the first of the two Data_element_definition (see 4.2.72) objects related by the Data_element_definition_relationship.

See 4.3.518 for the application assertion.

4.2.73.4 relation_type

The `relation_type` specifies the meaning of the relationship. The value is either user defined or predefined.

The predefined value of `relation_type` is one of the following:

- decomposition;
- dependency;
- substitution;
- value domain.

NOTE See 4.2.73.4.1 - 4.2.73.4.4 for the definition of each predefined value for `relation_type`.

4.2.73.4.1 decomposition

decomposition: The `Data_element_definition_relationship` defines a relationship where the related `Data_element_definition` (see 4.2.72) is member of a group of `Data_element_definition` (see 4.2.72) objects that is established by the relating `Data_element_definition` (see 4.2.72).

4.2.73.4.2 dependency

dependency: The `Data_element_definition_relationship` defines a relationship where the related `Data_element_definition` (see 4.2.72) is dependent upon the relating `Data_element_definition` (see 4.2.72).

4.2.73.4.3 substitution

substitution: The `Data_element_definition_relationship` defines a relationship where the related `Data_element_definition` (see 4.2.72) replaces the relating `Data_element_definition` (see 4.2.72).

4.2.73.4.4 value domain

value domain: The `Data_element_definition_relationship` defines a relationship where the values assigned to the related `Data_element_definition` (see 4.2.72) shall be within the limits indicated by the values assigned to the relating `Data_element_definition` (see 4.2.72).

EXAMPLE The output range of a 4-bit analog to digital converter is restricted to 16 discrete values, while the input voltage is restricted to a continuous range.

4.2.74 Data_element_relationship

A `Data_element_relationship` is the relation between two `Data_element` (see 4.2.70) objects.

ISO 10303-212:2001(E)

The data associated with an Data_element_relationship are the following:

- description;
- related;
- relating;
- relation_type.

4.2.74.1 description

The description specifies an alphanumeric string containing human-interpretable text that gives further details about the Data_element_relationship.

The description need not be specified for a particular Data_element_relationship.

4.2.74.2 related

The related specifies the second of the two Data_element (see 4.2.70) objects related by the Data_element_relationship.

See 4.3.519 for the application assertion.

4.2.74.3 relating

The relating specifies the first of the two Data_element (see 4.2.70) objects related by the Data_element_relationship.

See 4.3.520 for the application assertion.

4.2.74.4 relation_type

The relation_type specifies the meaning of the relationship. The value is either user defined or predefined.

The predefined value of relation_type is one of the following:

- decomposition;
- dependency;
- equivalence;
- substitution;
- tolerancing information.

NOTE 1 See 4.2.74.4.1 - 4.2.74.4.5 for the definition of each predefined value for relation_type.

NOTE 2 Data_element (see 4.2.70) objects that are related to each other in a sequential manner shall be captured as a one-dimensional array using Aggregated_value (see 4.2.7) objects.

4.2.74.4.1 decomposition

decomposition: The Data_element_relationship defines a relationship where the related Data_element (see 4.2.70) is one of the members of the group identified by the relating Data_element (see 4.2.70).

4.2.74.4.2 dependency

dependency: The Data_element_relationship defines a deriving relationship where the related Data_element (see 4.2.70) is based on the relating Data_element (see 4.2.70).

4.2.74.4.3 equivalence

equivalence: The Data_element_relationship defines a relationship where the related Data_element (see 4.2.70) represents the same matter of fact as by the relating Data_element (see 4.2.70).

EXAMPLE Two length values shall be considered to be the same, regardless of rounding differences.

4.2.74.4.4 substitution

substitution: The Data_element_relationship defines a relationship where the related Data_element (see 4.2.70) replaces the relating Data_element (see 4.2.70).

4.2.74.4.5 tolerancing information

tolerancing information: The Data_element_relationship defines a relationship where the related Data_element (see 4.2.70) provides information on the allowable variation of the value of the relating Data_element (see 4.2.70).

4.2.75 Data_element_specification

The Data_element_specification is the defining description of a Data_element_definition (see 4.2.72).

The data associated with an Data_element_specification are the following:

- definition;
- language_specification;
- note;
- remark;
- specification_of.

4.2.75.1 definition

The definition specifies the meaning of the associated Data_element (see 4.2.70) in human-interpretable language. It provides differentiation from all other Data_element (see 4.2.70) objects.

4.2.75.2 language_specification

The language_specification specifies a language spoken by human beings to communicate with each other verbally or in written form.

The language_specification need not be specified for a particular Data_element_specification.

See 4.3.522 for the application assertion.

4.2.75.3 note

The note specifies a statement that provides further information on the definition, which is essential to the understanding of the definition.

The note need not be specified for a particular Data_element_specification.

4.2.75.4 remark

The remark specifies human-interpretable text that gives further details about the Data_element_specification.

The remark need not be specified for a particular Data_element_specification.

4.2.75.5 specification_of

The specification_of specifies the Data_element_definition (see 4.2.72).

See 4.3.521 for the application assertion.

4.2.76 Data_element_value

A Data_element_value is the logical, numerical, or textual value of a User_defined_data_element (see 4.2.351) or an aggregate thereof.

Each Data_element_value is either an Aggregated_value (see 4.2.7) or a Single_value (see 4.2.316).

The data associated with a Data_element_value are the following:

- name.

4.2.76.1 name

The name specifies the identifier of the Data_element_value.

4.2.77 Date_and_person_assignment

A Date_and_person_assignment is a relation that associates a Date_and_person_or_organization (see 4.2.78) with an object.

The data associated with a `Date_and_person_assignment` are the following:

- `assigned_date_and_person`;
- `description`;
- `is_applied_to`;
- `role`.

4.2.77.1 `assigned_date_and_person`

The `assigned_date_and_person` specifies the `Date_and_person_or_organization` (see 4.2.78).

See 4.3.554 for the application assertion.

4.2.77.2 `description`

The `description` specifies an alphanumeric string containing human-interpretable text that gives further details about the `Date_and_person_assignment`.

The `description` need not be specified for a particular `Date_and_person_assignment`.

4.2.77.3 `is_applied_to`

The `is_applied_to` specifies the object with which the `Date_and_person_assignment` is associated.

Each `is_applied_to` may be one of the following: `Activity` (see 4.2.1), `Activity_element` (see 4.2.2), `Activity_method_assignment` (see 4.2.4), `Activity_relationship` (see 4.2.5), `Alternate_item_relationship` (see 4.2.11), `Approval_status` (see 4.2.25), `Assembly_component_relationship` (see 4.2.26), `Assembly_substitute_relationship` (see 4.2.28), `Cable_pull_information` (see 4.2.33), `Certification` (see 4.2.38), `Class_category_association` (see 4.2.40), `Class_condition_association` (see 4.2.41), `Class_inclusion_association` (see 4.2.42), `Class_specification_association` (see 4.2.44), `Class_structure_relationship` (see 4.2.45), `Classification_association` (see 4.2.46), `Classification_attribute` (see 4.2.47), `Classification_system` (see 4.2.48), `Complex_product` (see 4.2.51), `Complex_product_relationship` (see 4.2.52), `Composition_relationship` (see 4.2.55), `Configuration` (see 4.2.56), `Connectivity_allocation` (see 4.2.60), `Connectivity_definition` (see 4.2.61), `Connectivity_definition_relationship` (see 4.2.62), `Contract` (see 4.2.63), `Data_element` (see 4.2.70), `Data_element_association` (see 4.2.71), `Data_element_definition` (see 4.2.72), `Data_element_relationship` (see 4.2.74), `Data_element_specification` (see 4.2.75), `Design_discipline_item_definition` (see 4.2.86), `Device` (see 4.2.88), `Device_relationship` (see 4.2.89), `Document` (see 4.2.101), `Document_file` (see 4.2.106), `Document_file_relationship` (see 4.2.107), `Document_representation` (see 4.2.110), `Document_version` (see 4.2.114), `Document_version_relationship` (see 4.2.115), `Drawing` (see 4.2.119), `Drawing_sequence` (see 4.2.121), `Drawing_sheet` (see 4.2.122), `Drawing_sheet_relationship` (see 4.2.124), `Free_segment` (see 4.2.144), `Function_definition` (see 4.2.145), `Function_definition_relationship` (see 4.2.146), `Function_interface` (see 4.2.147), `Function_unit` (see 4.2.148), `Function_unit_relationship` (see 4.2.149), `Function_version` (see 4.2.150), `Function_version_relationship` (see 4.2.151), `Functional_connectivity_definition` (see 4.2.152), `Functional_connectivity_definition_relationship` (see 4.2.153), `Functional_unit_allocation` (see 4.2.154), `Functionality` (see 4.2.155), `General_classification` (see 4.2.156), `Generic_note` (see 4.2.159), `Interface` (see 4.2.170), `Interface_port` (see 4.2.171), `Interface_terminal` (see 4.2.174), `Item` (see 4.2.178), `Item_definition_relationship` (see 4.2.179), `Item_version` (see 4.2.182), `Item_version_relationship` (see 4.2.183), `Location` (see

ISO 10303-212:2001(E)

4.2.192), Location_relationship (see 4.2.194), Marking (see 4.2.199), Material (see 4.2.201), Node (see 4.2.208), Node_relationship (see 4.2.209), Notification (see 4.2.213), Notification_relationship (see 4.2.214), Offered_function_allocation (see 4.2.220), Organization_relationship (see 4.2.225), Path (see 4.2.232), Path_node (see 4.2.233), Path_node_relationship (see 4.2.234), Path_relationship (see 4.2.235), Person_in_organization (see 4.2.238), Person_in_organization_relationship (see 4.2.239), Physical_assembly_relationship (see 4.2.241), Physical_instance (see 4.2.243), Port (see 4.2.247), Port_allocation (see 4.2.248), Port_association (see 4.2.249), Preferred_item_allocation (see 4.2.258), Preferred_item_terminal_allocation (see 4.2.259), Process_variable (see 4.2.260), Process_variable_relationship (see 4.2.261), Product_class (see 4.2.263), Product_identification (see 4.2.268), Product_structure_relationship (see 4.2.270), Project (see 4.2.271), Requirement (see 4.2.285), Requirement_document_assignment (see 4.2.287), Route (see 4.2.290), Route_relationship (see 4.2.291), Routed_segment (see 4.2.293), Section (see 4.2.296), Section_end (see 4.2.297), Section_interface (see 4.2.298), Section_interface_relationship (see 4.2.299), Section_relationship (see 4.2.300), Security_classification (see 4.2.301), Security_level (see 4.2.302), Signal (see 4.2.309), Signal_relationship (see 4.2.311), Signal_value (see 4.2.313), Specification (see 4.2.323), Specification_category (see 4.2.324), Specification_expression (see 4.2.326), Specification_inclusion (see 4.2.327), Technical_system (see 4.2.336), Technical_system_relationship (see 4.2.337), Terminal (see 4.2.338), Work_order (see 4.2.364), or Work_request (see 4.2.365).

See 4.3.523, 4.3.524, 4.3.525, 4.3.526, 4.3.527, 4.3.528, 4.3.529, 4.3.530, 4.3.531, 4.3.532, 4.3.533, 4.3.534, 4.3.535, 4.3.536, 4.3.537, 4.3.538, 4.3.539, 4.3.540, 4.3.541, 4.3.542, 4.3.543, 4.3.544, 4.3.545, 4.3.546, 4.3.547, 4.3.548, 4.3.549, 4.3.550, 4.3.551, 4.3.552, 4.3.553, 4.3.555, 4.3.556, 4.3.557, 4.3.558, 4.3.559, 4.3.560, 4.3.561, 4.3.562, 4.3.563, 4.3.564, 4.3.565, 4.3.566, 4.3.567, 4.3.568, 4.3.569, 4.3.570, 4.3.571, 4.3.572, 4.3.573, 4.3.574, 4.3.575, 4.3.576, 4.3.577, 4.3.578, 4.3.579, 4.3.580, 4.3.581, 4.3.582, 4.3.583, 4.3.584, 4.3.585, 4.3.586, 4.3.587, 4.3.588, 4.3.589, 4.3.590, 4.3.591, 4.3.592, 4.3.593, 4.3.594, 4.3.595, 4.3.596, 4.3.597, 4.3.598, 4.3.599, 4.3.600, 4.3.601, 4.3.602, 4.3.603, 4.3.604, 4.3.605, 4.3.606, 4.3.607, 4.3.608, 4.3.609, 4.3.610, 4.3.611, 4.3.612, 4.3.613, 4.3.614, 4.3.615, 4.3.616, 4.3.617, 4.3.618, 4.3.619, 4.3.620, 4.3.621, 4.3.622, 4.3.623, 4.3.624, 4.3.625, 4.3.626, 4.3.627, 4.3.628, 4.3.629, 4.3.630, 4.3.631, 4.3.632, 4.3.633, 4.3.634, 4.3.635, 4.3.636, 4.3.637, 4.3.638, 4.3.639, 4.3.640, and 4.3.641 for the application assertions.

4.2.77.4 role

The role specifies the relationship between the point in time and the Person (see 4.2.237) or Organization (see 4.2.223) in the Date_and_person_assignment. The value is either user defined or predefined.

The predefined value of role is one of the following:

- creation;
- update.

NOTE See 4.2.77.4.1 - 4.2.77.4.2 for the definition of each predefined value for relation_type.

4.2.77.4.1 creation

creation: The assignment specifies that the referenced item has been created by the given Person (see 4.2.237) or Organization (see 4.2.223) at the given date and time.

4.2.77.4.2 update

update: The assignment specifies that the referenced item has been changed by the given Person (see 4.2.237) or Organization (see 4.2.223) at the given date and time.

4.2.78 Date_and_person_or_organization

A Date_and_person_or_organization is a Date_time (see 4.2.79) and a Person (see 4.2.237) or an Organization (see 4.2.223).

The data associated with a Date_and_person_or_organization are the following:

- associated_date;
- person_or_organization.

4.2.78.1 associated_date

The associated_date specifies the date component of a Date_and_person_or_organization.

See 4.3.642 for the application assertion.

4.2.78.2 person_or_organization

The person_or_organization specifies the Organization (see 4.2.223), the Person (see 4.2.237), or the Person_in_organization (see 4.2.238) that is part of the Date_and_person_or_organization.

Each person_or_organization may be one of the following: Organization (see 4.2.223) or Person_in_organization (see 4.2.238).

See 4.3.643 and 4.3.644 for the application assertions.

4.2.79 Date_time

A Date_time is the specification of a date and an optional time of day.

The data associated with a Date_time are the following:

- date;
- time.

4.2.79.1 date

The date specifies the calendar time conveying information about year, month, and day.

4.2.79.2 time

The time specifies a moment of occurrence measured by hour, minute, and second.

The time need not be specified for a particular Date_time.

4.2.80 Date_time_assignment

A Date_time_assignment is an association of Date_time (see 4.2.79) with some product data.

The data associated with a Date_time_assignment are the following:

- assigned_date_time;
- description;
- is_applied_to;
- role.

4.2.80.1 assigned_date_time

The assigned_date_time specifies the Date_time (see 4.2.79) that is associated with the product data.

See 4.3.676 for the application assertion.

4.2.80.2 description

The description specifies an alphanumeric string containing human-interpretable text that gives further details about the Date_time_assignment.

The description need not be specified for a particular Date_time_assignment.

4.2.80.3 is_applied_to

The is_applied_to specifies the product data with which the Date_time_assignment is associated.

Each is_applied_to may be one of the following: Activity (see 4.2.1), Activity_element (see 4.2.2), Activity_method_assignment (see 4.2.4), Activity_relationship (see 4.2.5), Alternate_item_relationship (see 4.2.11), Approval_status (see 4.2.25), Assembly_component_relationship (see 4.2.26), Assembly_substitute_relationship (see 4.2.28), Cable_pull_information (see 4.2.33), Certification (see 4.2.38), Class_category_association (see 4.2.40), Class_condition_association (see 4.2.41), Class_inclusion_association (see 4.2.42), Class_specification_association (see 4.2.44), Class_structure_relationship (see 4.2.45), Classification_association (see 4.2.46), Classification_attribute (see 4.2.47), Classification_system (see 4.2.48), Complex_product (see 4.2.51), Complex_product_relationship (see 4.2.52), Composition_relationship (see 4.2.55), Configuration (see 4.2.56), Connectivity_allocation (see 4.2.60), Connectivity_definition (see 4.2.61), Connectivity_definition_relationship (see 4.2.62), Contract (see 4.2.63), Data_element (see 4.2.70), Data_element_association (see 4.2.71), Data_element_definition (see 4.2.72), Data_element_relationship (see 4.2.74), Data_element_specification (see 4.2.75), Design_discipline_item_definition (see 4.2.86), Device (see 4.2.88), Device_relationship (see 4.2.89), Document (see 4.2.101), Document_file (see 4.2.106), Document_file_relationship (see 4.2.107), Document_representation (see 4.2.110), Document_version (see 4.2.114), Document_version_relationship (see 4.2.115), Drawing (see 4.2.119), Drawing_sequence (see 4.2.121), Drawing_sheet (see 4.2.122), Drawing_sheet_relationship (see 4.2.124), Free_segment (see 4.2.144), Function_definition (see 4.2.145), Function_definition_relationship (see 4.2.146), Function_interface (see 4.2.147), Function_unit (see 4.2.148), Function_unit_relationship (see 4.2.149), Function_version (see 4.2.150), Function_version_relationship (see 4.2.151), Functional_connectivity_definition (see 4.2.152), Functional_connectivity_definition_

relationship (see 4.2.153), Functional_unit_allocation (see 4.2.154), Functionality (see 4.2.155), General_classification (see 4.2.156), Generic_note (see 4.2.159), Interface (see 4.2.170), Interface_port (see 4.2.171), Interface_terminal (see 4.2.174), Item (see 4.2.178), Item_definition_relationship (see 4.2.179), Item_version (see 4.2.182), Item_version_relationship (see 4.2.183), Location (see 4.2.192), Location_relationship (see 4.2.194), Marking (see 4.2.199), Material (see 4.2.201), Node (see 4.2.208), Node_relationship (see 4.2.209), Notification (see 4.2.213), Notification_relationship (see 4.2.214), Offered_function_allocation (see 4.2.220), Organization_relationship (see 4.2.225), Path (see 4.2.232), Path_node (see 4.2.233), Path_node_relationship (see 4.2.234), Path_relationship (see 4.2.235), Person_in_organization (see 4.2.238), Person_in_organization_relationship (see 4.2.239), Physical_assembly_relationship (see 4.2.241), Physical_instance (see 4.2.243), Port (see 4.2.247), Port_allocation (see 4.2.248), Port_association (see 4.2.249), Preferred_item_allocation (see 4.2.258), Preferred_item_terminal_allocation (see 4.2.259), Process_variable (see 4.2.260), Process_variable_relationship (see 4.2.261), Product_class (see 4.2.263), Product_identification (see 4.2.268), Product_structure_relationship (see 4.2.270), Project (see 4.2.271), Requirement (see 4.2.285), Requirement_document_assignment (see 4.2.287), Route (see 4.2.290), Route_relationship (see 4.2.291), Routed_segment (see 4.2.293), Section (see 4.2.296), Section_end (see 4.2.297), Section_interface (see 4.2.298), Section_interface_relationship (see 4.2.299), Section_relationship (see 4.2.300), Security_classification (see 4.2.301), Security_level (see 4.2.302), Signal (see 4.2.309), Signal_relationship (see 4.2.311), Signal_value (see 4.2.313), Specification (see 4.2.323), Specification_category (see 4.2.324), Specification_expression (see 4.2.326), Specification_inclusion (see 4.2.327), Technical_system (see 4.2.336), Technical_system_relationship (see 4.2.337), Terminal (see 4.2.338), Work_order (see 4.2.364), or Work_request (see 4.2.365).

See 4.3.645, 4.3.646, 4.3.647, 4.3.648, 4.3.649, 4.3.650, 4.3.651, 4.3.652, 4.3.653, 4.3.654, 4.3.655, 4.3.656, 4.3.657, 4.3.658, 4.3.659, 4.3.660, 4.3.661, 4.3.662, 4.3.663, 4.3.664, 4.3.665, 4.3.666, 4.3.667, 4.3.668, 4.3.669, 4.3.670, 4.3.671, 4.3.672, 4.3.673, 4.3.674, 4.3.675, 4.3.677, 4.3.678, 4.3.679, 4.3.680, 4.3.681, 4.3.682, 4.3.683, 4.3.684, 4.3.685, 4.3.686, 4.3.687, 4.3.688, 4.3.689, 4.3.690, 4.3.691, 4.3.692, 4.3.693, 4.3.694, 4.3.695, 4.3.696, 4.3.697, 4.3.698, 4.3.699, 4.3.700, 4.3.701, 4.3.702, 4.3.703, 4.3.704, 4.3.705, 4.3.706, 4.3.707, 4.3.708, 4.3.709, 4.3.710, 4.3.711, 4.3.712, 4.3.713, 4.3.714, 4.3.715, 4.3.716, 4.3.717, 4.3.718, 4.3.719, 4.3.720, 4.3.721, 4.3.722, 4.3.723, 4.3.724, 4.3.725, 4.3.726, 4.3.727, 4.3.728, 4.3.729, 4.3.730, 4.3.731, 4.3.732, 4.3.733, 4.3.734, 4.3.735, 4.3.736, 4.3.737, 4.3.738, 4.3.739, 4.3.740, 4.3.741, 4.3.742, 4.3.743, 4.3.744, 4.3.745, 4.3.746, 4.3.747, 4.3.748, 4.3.749, 4.3.750, 4.3.751, 4.3.752, 4.3.753, 4.3.754, 4.3.755, 4.3.756, 4.3.757, 4.3.758, 4.3.759, 4.3.760, 4.3.761, 4.3.762, and 4.3.763 for the application assertions.

4.2.80.4 role

The role specifies the action associated with the Date_time_assignment. The value is either user defined or predefined.

ISO 10303-212:2001(E)

The predefined value of role is one of the following:

- classification date;
- creation;
- installation;
- production;
- registration;
- update.

NOTE See 4.2.80.4.1 - 4.2.80.4.6 for the definition of each predefined value for role.

4.2.80.4.1 classification date

classification date: The assignment specifies that the specified object is classified at the given date and time. This value shall only be used, if the Date_time_assignment refers to instances of Classification_association (see 4.2.46) as 'is_applied_to'.

4.2.80.4.2 creation

creation: The assignment specifies that the referenced item was created at the given date and time.

4.2.80.4.3 installation

installation: The assignment specifies that the referenced item was mounted in a product at the given date and time.

4.2.80.4.4 production

production: The assignment specifies that the referenced item was produced at the given date and time.

4.2.80.4.5 registration

registration: The assignment specifies that the referenced item was registered at the given date and time.

4.2.80.4.6 update

update: The assignment specifies that the referenced item was changed at the given date and time.

4.2.81 Date_time_interval_assignment

A Date_time_interval_assignment is an association of an Interval_of_time (see 4.2.177) with some product data.

The data associated with a `Date_time_assignment` (see 4.2.80) are the following:

- `assigned_time_interval`;
- `description`;
- `is_applied_to`;
- `role`.

4.2.81.1 `assigned_time_interval`

The `assigned_time_interval` specifies the `Interval_of_time` (see 4.2.177) that is associated with the product data.

See 4.3.825 for the application assertion.

4.2.81.2 `description`

The `description` specifies an alphanumeric string containing human-interpretable text that gives further details about the `Date_time_assignment` (see 4.2.80).

The `description` need not be specified for a particular `Date_time_interval_assignment`.

4.2.81.3 `is_applied_to`

The `is_applied_to` specifies the set of objects of product data with which the `Date_time_interval_assignment` is associated.

There shall be at least one object that the `Date_time_interval_assignment` is assigned to.

Each `is_applied_to` may be one of the following: `Activity` (see 4.2.1), `Activity_element` (see 4.2.2), `Activity_method_assignment` (see 4.2.4), `Activity_relationship` (see 4.2.5), `Alternate_item_relationship` (see 4.2.11), `Approval_status` (see 4.2.25), `Assembly_component_relationship` (see 4.2.26), `Assembly_substitute_relationship` (see 4.2.28), `Cable_pull_information` (see 4.2.33), `Certification` (see 4.2.38), `Class_category_association` (see 4.2.40), `Class_condition_association` (see 4.2.41), `Class_inclusion_association` (see 4.2.42), `Class_specification_association` (see 4.2.44), `Class_structure_relationship` (see 4.2.45), `Classification_association` (see 4.2.46), `Classification_attribute` (see 4.2.47), `Classification_system` (see 4.2.48), `Complex_product` (see 4.2.51), `Complex_product_relationship` (see 4.2.52), `Composition_relationship` (see 4.2.55), `Configuration` (see 4.2.56), `Connectivity_allocation` (see 4.2.60), `Connectivity_definition` (see 4.2.61), `Connectivity_definition_relationship` (see 4.2.62), `Contract` (see 4.2.63), `Data_element` (see 4.2.70), `Data_element_association` (see 4.2.71), `Data_element_definition` (see 4.2.72), `Data_element_relationship` (see 4.2.74), `Data_element_specification` (see 4.2.75), `Design_discipline_item_definition` (see 4.2.86), `Device` (see 4.2.88), `Device_relationship` (see 4.2.89), `Document` (see 4.2.101), `Document_file` (see 4.2.106), `Document_file_relationship` (see 4.2.107), `Document_representation` (see 4.2.110), `Document_version` (see 4.2.114), `Document_version_relationship` (see 4.2.115), `Drawing` (see 4.2.119), `Drawing_sequence` (see 4.2.121), `Drawing_sheet` (see 4.2.122), `Drawing_sheet_relationship` (see 4.2.124), `Free_segment` (see 4.2.144), `Function_definition` (see 4.2.145), `Function_definition_relationship` (see 4.2.146), `Function_interface` (see 4.2.147), `Function_unit` (see 4.2.148), `Function_unit_relationship` (see 4.2.149), `Function_version` (see 4.2.150), `Function_version_relationship` (see 4.2.151), `Functional_connectivity_definition` (see 4.2.152), `Functional_connectivity_definition_`

ISO 10303-212:2001(E)

relationship (see 4.2.153), Functional_unit_allocation (see 4.2.154), Functionality (see 4.2.155), General_classification (see 4.2.156), Generic_note (see 4.2.159), Interface (see 4.2.170), Interface_port (see 4.2.171), Interface_terminal (see 4.2.174), Item (see 4.2.178), Item_definition_relationship (see 4.2.179), Item_version (see 4.2.182), Item_version_relationship (see 4.2.183), Location (see 4.2.192), Location_relationship (see 4.2.194), Marking (see 4.2.199), Material (see 4.2.201), Node (see 4.2.208), Node_relationship (see 4.2.209), Notification (see 4.2.213), Notification_relationship (see 4.2.214), Offered_function_allocation (see 4.2.220), Organization_relationship (see 4.2.225), Path (see 4.2.232), Path_node (see 4.2.233), Path_node_relationship (see 4.2.234), Path_relationship (see 4.2.235), Person_in_organization (see 4.2.238), Person_in_organization_relationship (see 4.2.239), Physical_assembly_relationship (see 4.2.241), Physical_instance (see 4.2.243), Port (see 4.2.247), Port_allocation (see 4.2.248), Port_association (see 4.2.249), Preferred_item_allocation (see 4.2.258), Preferred_item_terminal_allocation (see 4.2.259), Process_variable (see 4.2.260), Process_variable_relationship (see 4.2.261), Product_class (see 4.2.263), Product_identification (see 4.2.268), Product_structure_relationship (see 4.2.270), Project (see 4.2.271), Requirement (see 4.2.285), Requirement_document_assignment (see 4.2.287), Route (see 4.2.290), Route_relationship (see 4.2.291), Routed_segment (see 4.2.293), Section (see 4.2.296), Section_end (see 4.2.297), Section_interface (see 4.2.298), Section_interface_relationship (see 4.2.299), Section_relationship (see 4.2.300), Security_classification (see 4.2.301), Security_level (see 4.2.302), Signal (see 4.2.309), Signal_relationship (see 4.2.311), Signal_value (see 4.2.313), Specification (see 4.2.323), Specification_category (see 4.2.324), Specification_expression (see 4.2.326), Specification_inclusion (see 4.2.327), Technical_system (see 4.2.336), Technical_system_relationship (see 4.2.337), Terminal (see 4.2.338), Work_order (see 4.2.364), or Work_request (see 4.2.365).

See 4.3.764, 4.3.765, 4.3.766, 4.3.767, 4.3.768, 4.3.769, 4.3.770, 4.3.771, 4.3.772, 4.3.773, 4.3.774, 4.3.775, 4.3.776, 4.3.777, 4.3.778, 4.3.779, 4.3.780, 4.3.781, 4.3.782, 4.3.783, 4.3.784, 4.3.785, 4.3.786, 4.3.787, 4.3.788, 4.3.789, 4.3.790, 4.3.791, 4.3.792, 4.3.793, 4.3.794, 4.3.795, 4.3.796, 4.3.797, 4.3.798, 4.3.799, 4.3.800, 4.3.801, 4.3.802, 4.3.803, 4.3.804, 4.3.805, 4.3.806, 4.3.807, 4.3.808, 4.3.809, 4.3.810, 4.3.811, 4.3.812, 4.3.813, 4.3.814, 4.3.815, 4.3.816, 4.3.817, 4.3.818, 4.3.819, 4.3.820, 4.3.821, 4.3.822, 4.3.823, 4.3.824, 4.3.826, 4.3.827, 4.3.828, 4.3.829, 4.3.830, 4.3.831, 4.3.832, 4.3.833, 4.3.834, 4.3.835, 4.3.836, 4.3.837, 4.3.838, 4.3.839, 4.3.840, 4.3.841, 4.3.842, 4.3.843, 4.3.844, 4.3.845, 4.3.846, 4.3.847, 4.3.848, 4.3.849, 4.3.850, 4.3.851, 4.3.852, 4.3.853, 4.3.854, 4.3.855, 4.3.856, 4.3.857, 4.3.858, 4.3.859, 4.3.860, 4.3.861, 4.3.862, 4.3.863, 4.3.864, 4.3.865, 4.3.866, 4.3.867, 4.3.868, 4.3.869, 4.3.870, 4.3.871, 4.3.872, 4.3.873, 4.3.874, 4.3.875, 4.3.876, 4.3.877, 4.3.878, 4.3.879, 4.3.880, 4.3.881, and 4.3.882 for the application assertions.

4.2.81.4 role

The role specifies the action associated with the Date_time_interval_assignment. The value is either user defined or predefined.

The predefined value of role is one of the following:

— installation.

NOTE See 4.2.81.4.1 for the definition of each predefined value for role.

4.2.81.4.1 installation

installation: The assignment specifies that the referenced object was mounted in a product at the given interval of time.

4.2.82 Dated_configuration

A Dated_configuration is a type of Manufacturing_configuration (see 4.2.198) that is a configuration that applies onwards from a given date, or between a start and an end date.

The data associated with a Dated_configuration are the following:

- end_date;
- start_date.

4.2.82.1 end_date

The end_date specifies the date and time when the validity of the 'configured_element' is not defined any longer. If the end_date is not specified, the Dated_configuration is considered as valid forever from the start_date.

The end_date need not be specified for a particular Dated_configuration.

4.2.82.2 start_date

The start_date specifies the first date when the Dated_configuration is valid.

4.2.83 Datum_feature_callout

A Datum_feature_callout is a type of Draughting_callout (see 4.2.117) that is used to identify a point, line, or plane as a datum and that specifies the designation to be used as identification of that datum.

4.2.84 Datum_target_callout

A Datum_target_callout is a type of Draughting_callout (see 4.2.117) that is used to identify points, lines, and surfaces of contact, on a part, used in establishing a reference datum. The callout contains an alphanumeric designation and, where applicable, a specification of the diametrical size of the target area.

4.2.85 Descriptive_specification

A Descriptive_specification is the definitional description of an item.

NOTE Usually an item that is specified by a Descriptive_specification is not represented in the assembly structure of the system.

EXAMPLE A Descriptive_specification can be used to describe the characteristics that distinguish a final part from the corresponding neutral part.

The data associated with a Descriptive_specification are the following:

ISO 10303-212:2001(E)

- description;
- id.

4.2.85.1 description

The description specifies an alphanumeric string containing human-interpretable text that gives further details about the Descriptive_specification.

4.2.85.2 id

The id specifies the identifier of the Descriptive_specification.

The id need not be specified for a particular Descriptive_specification.

4.2.86 Design_discipline_item_definition

A Design_discipline_item_definition is a view of an Item_version (see 4.2.182) relevant for the requirements of one or more life-cycle stages and application domains. This view collects product data for a specific task.

EXAMPLE Different methods of analysis, such as fault current analysis, voltage drop analysis, or electromagnetic interference analysis, may require distinctive viewpoints. To support this idea, the user may define the subjects of the analyses individually by defining different instances of a Design_discipline_item_definition. Each of these instances refer to the same instance of Item_version (see 4.2.182).

NOTE 1 The selection of data describing an Item (see 4.2.178) can be different for assembly purposes, packing purposes, or analysis purposes.

NOTE 2 The use of the Design_discipline_item_definition object is not confined to the design stage.

Each Design_discipline_item_definition may be an Assembly_definition (see 4.2.27).

The data associated with a Design_discipline_item_definition are the following:

- additional_context;
- associated_item_version;
- id;
- initial_context;
- name.

4.2.86.1 additional_context

The additional_context specifies the set of Application_context (see 4.2.22) objects in which this view of the Item_version (see 4.2.182) is also relevant. The additional_context shall not contain the Application_context (see 4.2.22) that is referenced as the 'initial_context'.

See 4.3.883 for the application assertion.

4.2.86.2 associated_item_version

The `associated_item_version` specifies the `Item_version` (see 4.2.182) for which the `Design_discipline_item_definition` is a view.

See 4.3.885 for the application assertion.

4.2.86.3 id

The `id` specifies the identifier of the `Design_discipline_item_definition`.

4.2.86.4 initial_context

The `initial_context` specifies the `Application_context` (see 4.2.22) in which this view of the `Item_version` (see 4.2.182) has been designed primarily.

See 4.3.884 for the application assertion.

4.2.86.5 name

The `name` specifies a speaking designation of the `Design_discipline_item_definition`.

The `name` need not be specified for a particular `Design_discipline_item_definition`.

4.2.87 Detached_representation_reference

A `Detached_representation_reference` is a type of `Cross_reference` (see 4.2.64) that is a reference made from one part of a diagram to another part between the different presentations of the electrotechnical system. Using references is a widely used technique to keep diagrams clear.

EXAMPLE Reference among the detached representations and the attached representation of a piece of equipment.

The data associated with a `Detached_representation_reference` are the following:

- `part_of`;
- `refers_to`.

4.2.87.1 part_of

The `part_of` specifies the `Annotation_element` (see 4.2.15) the `Detached_representation_reference` belongs to.

See 4.3.886 for the application assertion.

ISO 10303-212:2001(E)

4.2.87.2 refers_to

The refers_to specifies the Annotation_element (see 4.2.15) the Detached_representation_reference references.

See 4.3.887 for the application assertion.

4.2.88 Device

A Device is a type of Product_constituent (see 4.2.266) that is an occurrence of a Design_discipline_item_definition (see 4.2.86) object.

NOTE 1 A Device may be instantiated more than once since each instance is an individual occurrence of the piece of equipment that is characterized by the Design_discipline_item_definition (see 4.2.86).

EXAMPLE 1 In a specific circuit, the Item (see 4.2.178) 'lamp' is defined once. This Design_discipline_item_definition (see 4.2.86) carries all the information defining the lamp (e.g., its terminals) that is independent from its usage. Additionally, three Device objects for this Design_discipline_item_definition (see 4.2.86) exist because three equal lamps are used within this particular circuit. Each of these instances can be connected individually.

Each Device is either a Quantified_device (see 4.2.276), a Selected_device (see 4.2.303), a Single_device (see 4.2.314), or a Specified_device (see 4.2.328).

The data associated with a Device are the following:

- definition;
- description;
- extended_designation;
- id.

4.2.88.1 definition

The definition specifies the reference to the associated defining Design_discipline_item_definition (see 4.2.86) or Product_identification (see 4.2.268) object.

Each definition may be one of the following: Design_discipline_item_definition (see 4.2.86) or Product_identification (see 4.2.268).

See 4.3.888 and 4.3.890 for the application assertions.

4.2.88.2 description

The description specifies an alphanumerical string containing human-interpretable text that gives further details about the Device.

The description need not be specified for a particular Device.

4.2.88.3 extended_designation

The extended_designation specifies a structured label for the Device.

NOTE 2 The label assigned through extended_designation shall be identical to the label assigned by the 'id' attribute.

EXAMPLE 2 IEC 61346-1 specifies designations and structuring principles for devices.

The extended_designation need not be specified for a particular Device.

See 4.3.889 for the application assertion.

4.2.88.4 id

The id specifies an identifier for the Device.

4.2.89 Device_relationship

A Device_relationship is the relation between two Device (see 4.2.88) objects.

The data associated with an Device_relationship are the following:

- description;
- related;
- relating;
- relation_type.

4.2.89.1 description

The description specifies an alphanumerical string containing human-interpretable text that gives further details about the Device_relationship.

The description need not be specified for a particular Device_relationship.

4.2.89.2 related

The related specifies the second of the two Device (see 4.2.88) objects related by the Device_relationship.

See 4.3.891 for the application assertion.

4.2.89.3 relating

The relating specifies the first of the two Device (see 4.2.88) objects related by the Device_relationship.

See 4.3.892 for the application assertion.

4.2.89.4 relation_type

The relation_type specifies the meaning of the relationship. The value is either user defined or predefined.

The predefined value of relation_type is one of the following:

- associated equipment;
- derivation;
- envelope;
- redundancy;
- shield;
- substitution.

NOTE See 4.2.89.4.1 - 4.2.89.4.6 for the definition of each predefined value for relation_type.

4.2.89.4.1 associated equipment

associated equipment: The Device_relationship defines a relationship where the related Device (see 4.2.88) is equipment that is assigned to the related Device (see 4.2.88) with the intention to support it in performing its task.

EXAMPLE 1 The association of the strain relief to a connector during the installation process.

4.2.89.4.2 derivation

derivation: The Device_relationship defines a deriving relationship where the related Device (see 4.2.88) is based on the relating Device (see 4.2.88).

4.2.89.4.3 envelope

envelope: The Device_relationship defines a relationship where the related Device (see 4.2.88) is enclosed by the relating Device (see 4.2.88).

EXAMPLE 2 Using an overbraid or taping are methods to envelop wires.

4.2.89.4.4 redundancy

redundancy: The Device_relationship defines a relationship where the related Devices replicated by the relating Device (see 4.2.88).

EXAMPLE 3 To provide for a fail-safe service two drives do the work that could be done by one motor. If one drive fails, the other is still in service.

4.2.89.4.5 shield

shield: The Device_relationship defines a relationship where the relating Device (see 4.2.88) provides the screen against electromagnetic interference. The related Device (see 4.2.88) is considered to be

inside the screen. If more than one shield is present, there shall be a Device_relationship where the relating Device (see 4.2.88) is the outer shield and the related Device (see 4.2.88) is the inner shield.

NOTE In cases when the screens do not enclose the shielded hardware the 'description' attribute shall specify the arrangement of the screens.

4.2.89.4.6 substitution

substitution: The Device_relationship defines a relationship where the related Device (see 4.2.88) replaces the relating Device (see 4.2.88).

4.2.90 Diameter_dimension

A Diameter_dimension is a type of Dimension (see 4.2.93) that is the graphical presentation of the value of the diametrical size of a circular element.

The data associated with a Diameter_dimension are the following:

- component;
- extent.

4.2.90.1 component

The component specifies the projection lines that shows the extension of the points, lines, or surfaces that bound the measurement.

See 4.3.894 for the application assertion.

4.2.90.2 extent

The extent specifies the dimension line that graphically presents where the dimension value applies.

See 4.3.893 for the application assertion.

4.2.91 Digital_document

A Digital_document is a type of Document_representation (see 4.2.110) that is a set of data in electronic form that is intended to give further information about the product data.

NOTE The content of the Digital_document need not be specified by using any part of ISO 10303.

EXAMPLE A Digital_document contains native data from applications such as desktop publishing systems or simulation systems.

The data associated with a Digital_document are the following:

- file.

4.2.91.1 file

ISO 10303-212:2001(E)

The file specifies the `Digital_file` (see 4.2.92) that contains the data.

See 4.3.895 for the application assertion.

4.2.92 Digital_file

The `Digital_file` is a type of `Document_file` (see 4.2.106) that is a collection of related data stored under one name.

4.2.93 Dimension

A `Dimension` is a type of `Draughting_annotation` (see 4.2.116) that is the graphical presentation of a dimension value, associated information, and the necessary symbology to accurately depict its area of application.

Each `Dimension` is either an `Angular_dimension` (see 4.2.13), a `Curve_dimension` (see 4.2.69), a `Diameter_dimension` (see 4.2.90), a `Leader_directed_dimension` (see 4.2.187), a `Linear_dimension` (see 4.2.190), an `Ordinate_dimension` (see 4.2.222), or a `Radius_dimension` (see 4.2.277).

4.2.94 Dimension_callout

A `Dimension_callout` is the text and symbols in the presentation of a dimension that represent the dimension value, dimension units, tolerance information, and any related notes.

Each `Dimension_callout` is either a `Structured_dimension_callout` (see 4.2.332) or a `Unstructured_dimension_callout` (see 4.2.349).

The data associated with a `Dimension_callout` are the following:

- `defined_primary_dimension`;
- `defined_secondary_dimension`.

4.2.94.1 defined_primary_dimension

The `defined_primary_dimension` specifies the dimension in which the dimension value, tolerance information, and any associated notes of the `Dimension_callout` are given in the primary unit of measure for the drawing view, drawing sheet, or drawing in which the dimension appears.

The `defined_primary_dimension` need not be specified for a particular `Dimension_callout`.

See 4.3.896 for the application assertion.

4.2.94.2 defined_secondary_dimension

The `defined_secondary_dimension` specifies the dimension in which the dimension value, tolerance information, and any associated notes of the `Dimension_callout` are given in a different unit of measure than that given for the drawing view, drawing sheet, or drawing in which the dimension appears.

The `defined_secondary_dimension` need not be specified for a particular `Dimension_callout`.

See 4.3.897 for the application assertion.

4.2.95 Dimension_line

A Dimension_line is a type of Directed_curve (see 4.2.99) that is used in the graphical presentation of a dimension value along with other symbology, if necessary, to show the extent of the application of the value.

EXAMPLE Terminator symbols may be associated with a Dimension_line.

4.2.96 Dimension_line_terminator

A Dimension_line_terminator is an annotation symbol that is applied to a dimension line and used to identify the endpoint or point of the application of the directed annotation.

The data associated with a Dimension_line_terminator are the following:

- line;
- symbol.

4.2.96.1 line

The line specifies the Dimension_line (see 4.2.95) that the symbol applies to.

See 4.3.899 for the application assertion.

4.2.96.2 symbol

The symbol specifies an Annotation_symbol (see 4.2.20) that is used to identify the endpoint or point of application of the directed annotation.

See 4.3.898 for the application assertion.

4.2.97 Dimension_sequence_pair

A Dimension_sequence_pair is the relationship between two adjacent dimensions that share a projection line.

Each Dimension_sequence_pair is either a Chained_dimension_pair (see 4.2.39) or a Parallel_dimension_pair (see 4.2.230).

The data associated with a Dimension_sequence_pair are the following:

- predecessor;
- successor.

4.2.97.1 predecessor

The predecessor specifies the dimension that is displayed first in a dimension sequence.

ISO 10303-212:2001(E)

See 4.3.900 for the application assertion.

4.2.97.2 successor

The successor specifies the dimension that is displayed second in a dimension sequence.

See 4.3.901 for the application assertion.

4.2.98 Dimension_symbol

A Dimension_symbol is a type of Predefined_symbol (see 4.2.255) that is used in conjunction with a dimension value to convey the context of the dimension value.

EXAMPLE A diameter symbol may be used in conjunction with a dimension value to denote a diameter dimension.

The predefined dimension symbols that shall be supported by all implementations of this part of ISO 10303 are dependent on the height (h) of the text that the symbol accompanies. The height of the characters for the predefined symbols specified here shall be $h = 2.5$ mm. The illustrations shown in Figure 12 are oriented as they appear when associated with a horizontal dimension line.

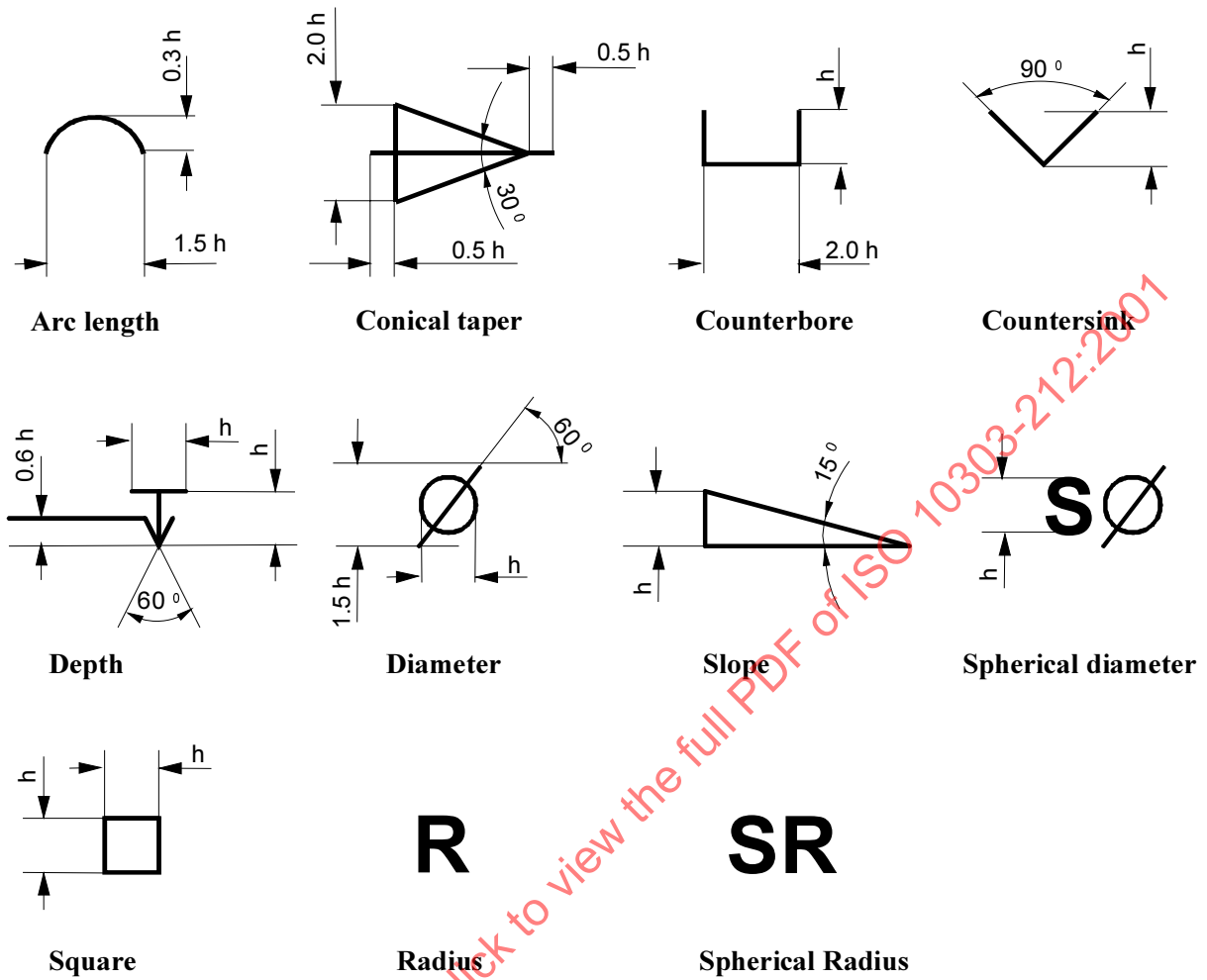

Figure 12 - Predefined dimension symbols

The data associated with a Dimension_symbol are the following:

— symbol_type.

4.2.98.1 symbol_type

The symbol_type specifies an alphanumerical string identifying the Dimension_symbol in accordance with the definitions given above.

ISO 10303-212:2001(E)

The value of symbol_type is one of the following:

- arc length;
- conical taper;
- counterbore;
- countersink;
- depth;
- diameter;
- slope;
- spherical diameter;
- square;
- radius;
- spherical radius.

NOTE See 4.2.98.1.1 - 4.2.98.1.11 for the definition of each permissible value for symbol_type.

4.2.98.1.1 arc length

arc length: An arc length symbol is a graphical symbol used in conjunction with a dimension value to indicate that the curve dimension is an arc length measured along the curved line or surface. An arc length symbol is depicted as one line segment that forms a part of a circle. The origin of the symbol corresponds to the starting point on the left of the arc line. The size and graphical representation of the symbol are shown in Figure 12.

4.2.98.1.2 conical taper

conical taper: A conical taper symbol is a graphical symbol used in conjunction with a dimension value to indicate that the value given is the ratio of the difference in the diameters of two sections taken perpendicular to the datum axis of a cone and the distance between the two sections. A conical taper symbol is depicted as an isosceles triangle and a line placed as a bisector to the angle created by the two equal sides. The origin of the symbol corresponds to the intersection point of the two equal sides. The size and graphical representation of the symbol are shown in Figure 12.

4.2.98.1.3 counterbore

counterbore: A counterbore symbol is a graphical symbol used in conjunction with a dimension value to indicate that the dimension value specifies the size of a counterbored hole. A counterbored hole is a cylindrical hole of larger diameter than its basis hole. Both holes share a common centre axis and the bottom of the counterbored hole is planar and perpendicular to the centre axis. A counterbore symbol is depicted as an open rectangle. The origin of the symbol is the geometrical centre of the rectangle. The size and graphical representation of the symbol are shown in Figure 12.

4.2.98.1.4 countersink

countersink: A countersink symbol is a graphical symbol used in conjunction with a dimension value to indicate that the associated dimension value applies to a countersink that is concentric to a basis hole. A countersink is a conical taper detail located at the end of an existing or basis hole. The diameter of the taper detail is larger than the diameter of the basis hole at the surface and decreases at a constant rate as a function of distance along the centre axis of the basis hole until the two diameters are equal. A countersink is depicted as an open triangle. The origin of the symbol is the intersection point of the two visible sides. The size and graphical representation of the symbol are shown in Figure 12.

4.2.98.1.5 depth

depth: A depth symbol is a graphical symbol used in conjunction with a dimension value to indicate that the dimension value applies to the depth of the feature. A depth symbol is depicted as an arrow with a line placed perpendicular to the end opposite the arrowhead. The origin of the symbol is the top of the arrowhead. The size and graphical representation of the symbol are shown in Figure 12.

4.2.98.1.6 diameter

diameter: A diameter symbol is a graphical symbol used in conjunction with a dimension value to indicate that the dimension value applies diametrically. A diameter is depicted as a circle crossed by a line going through the centre. The origin of the symbol is the centre point of the circle. The size and graphical representation of the symbol are shown in Figure 12.

4.2.98.1.7 slope

slope: A slope symbol is a graphical symbol used in conjunction with a dimension value to indicate that the dimension value specifies the ratio of the change in the vertical direction to the change in horizontal direction. A slope symbol is depicted as a right triangle. The origin of the symbol is the intersection of the two perpendicular sides of the triangle. The size and graphical representation of the symbol are shown in Figure 12.

4.2.98.1.8 spherical diameter

spherical diameter: A spherical diameter symbol is a graphical symbol used in conjunction with a dimension value to indicate that the dimension value applies to the surface or surfaces. A spherical diameter is depicted as a diameter symbol as noted above and the letter 'S' before it. The origin of the symbol is the geometrical centre of an imaginary surrounding box around the whole symbol. The size and graphical representation of the symbol are shown in Figure 12.

4.2.98.1.9 square

square: A square symbol is a graphical symbol used in conjunction with a dimension value to indicate that the dimension value applies linearly to two orthogonal geometric elements that form two adjacent sides of a square feature. A square is depicted as a rectangle. The origin of the symbol is the geometrical centre of the rectangle. The size and graphical representation of the symbol are shown in Figure 12.

ISO 10303-212:2001(E)

4.2.98.1.10 radius

radius: A radius symbol is a graphical symbol used in conjunction with a dimension value to indicate that the dimension value applies radially. A radius is depicted by the letter 'R'. The origin of the symbol is the origin of the letter. The size and graphical representation of the symbol are shown in Figure 12.

4.2.98.1.11 spherical radius

spherical radius: A spherical radius is a graphical symbol used in conjunction with a dimension value to indicate that the dimension value applies radially to all points on the dimensioned surface. A spherical radius is depicted by the letters 'S' and 'R'. The origin of the symbol is the geometrical centre of an imaginary box surrounding the whole symbol. The size and graphical representation of the symbol are shown in Figure 12.

4.2.99 Directed_curve

A Directed_curve is a type of Annotation_curve (see 4.2.14) that is used to guide annotation to a specific feature or area of a drawing view or drawing sheet.

Each Directed_curve is either a Dimension_line (see 4.2.95), a Leader (see 4.2.186), or a Projection_line (see 4.2.273).

The data associated with a Directed_curve are the following:

— directed_callout.

4.2.99.1 directed_callout

The directed_callout specifies the Draughting_callout (see 4.2.117) that is directed by means of the curve.

The directed_callout need not be specified for a particular Directed_curve.

See 4.3.902 for the application assertion.

4.2.100 Direction_range

A Direction_range is the specification of the sector under which connecting lines are allowed to be drawn onto a Schematic_node (see 4.2.294).

NOTE The information provided by the `Direction_range` can be used by a routing algorithm to place connection lines automatically on a schematic diagram.

The data associated with a `Direction_range` are the following:

- `associated_connect_area`;
- `maximum_angle`;
- `minimum_angle`.

4.2.100.1 associated_connect_area

The `associated_connect_area` specifies the `Connect_area` (see 4.2.57) object that may be approached under the given angles.

See 4.3.903 for the application assertion.

4.2.100.2 maximal_angle

The `maximal_angle` specifies the end angle of the sector. The angles are defined in relation to the coordinate space of the symbol.

4.2.100.3 minimal_angle

The `minimal_angle` specifies the start angle of the sector. The angles are defined in relation to the coordinate space of the symbol.

4.2.101 Document

A Document is the reference to digital data or nondigital data that are not within the scope of ISO 10303.

The data associated with a Document are the following:

- `description`;
- `extended_designation`;
- `id`;
- `name`.

4.2.101.1 description

The `description` specifies an alphanumerical string containing human-interpretable text that gives further details about the Document.

The `description` need not be specified for a particular Document.

4.2.101.2 extended_designation

ISO 10303-212:2001(E)

The `extended_designation` specifies a structured label for the Document.

NOTE The label assigned through `extended_designation` shall be identical to the label assigned by the 'id' attribute.

EXAMPLE IEC 62023 specifies designations and structuring principles for documents.

The `extended_designation` need not be specified for a particular Document.

See 4.3.904 for the application assertion.

4.2.101.3 id

The `id` specifies the identifier for the Document.

4.2.101.4 name

The `name` specifies a speaking designation of the Document.

The `name` need not be specified for a particular Document.

4.2.102 Document_assignment

A `Document_assignment` is a relation that associates a `Document_version` (see 4.2.114) with an item.

The data associated with a `Document_assignment` are the following:

- `assigned_document`;
- `is_assigned_to`;
- `role`.

4.2.102.1 assigned_document

The `assigned_document` specifies the `Document_version` (see 4.2.114).

Each `assigned_document` may be one of the following: `Document` (see 4.2.101), `Document_file` (see 4.2.106), `Document_representation` (see 4.2.110), or `Document_version` (see 4.2.114).

See 4.3.930, 4.3.931, 4.3.932, and 4.3.933 for the application assertions.

4.2.102.2 is_assigned_to

The `is_assigned_to` specifies the item with which the `Document_version` (see 4.2.114) is associated.

Each `is_assigned_to` may be one of the following: `Activity` (see 4.2.1), `Activity_element` (see 4.2.2), `Activity_method` (see 4.2.3), `Address` (see 4.2.6), `Approval` (see 4.2.23), `Approval_status` (see 4.2.25), `Assembly_component_relationship` (see 4.2.26), `Cable_pull_information` (see 4.2.33), `Certification` (see 4.2.38), `Class_category_association` (see 4.2.40), `Class_condition_association` (see 4.2.41), `Class_inclusion_association` (see 4.2.42), `Class_specification_association` (see 4.2.44), `Classification_association` (see 4.2.46), `Classification_attribute` (see 4.2.47), `Classification_system` (see 4.2.48), `Complex_product` (see 4.2.51), `Connectivity_definition` (see 4.2.61), `Contract` (see

4.2.63), Data_element (see 4.2.70), Data_element_definition (see 4.2.72), Data_element_specification (see 4.2.75), Descriptive_specification (see 4.2.85), Design_discipline_item_definition (see 4.2.86), Device (see 4.2.88), Drawing (see 4.2.119), Drawing_sheet (see 4.2.122), Drawing_view (see 4.2.125), Function_definition (see 4.2.145), Function_interface (see 4.2.147), Function_unit (see 4.2.148), Function_version (see 4.2.150), Functional_connectivity_definition (see 4.2.152), Functionality (see 4.2.155), General_classification (see 4.2.156), General_classification (see 4.2.156), Generic_note (see 4.2.159), Interface (see 4.2.170), Interface_port (see 4.2.171), Interface_terminal (see 4.2.174), Item (see 4.2.178), Item_definition_relationship (see 4.2.179), Item_identification (see 4.2.180), Item_version (see 4.2.182), Location (see 4.2.192), Marking (see 4.2.199), Node (see 4.2.208), Notification (see 4.2.213), Object_designation (see 4.2.217), Organization (see 4.2.223), Path (see 4.2.232), Path_node (see 4.2.233), Person (see 4.2.237), Physical_assembly_relationship (see 4.2.241), Physical_instance (see 4.2.243), Port (see 4.2.247), Process_variable (see 4.2.260), Product_class (see 4.2.263), Product_identification (see 4.2.268), Product_structure_relationship (see 4.2.270), Project (see 4.2.271), Retention_period (see 4.2.289), Route (see 4.2.290), Section (see 4.2.296), Section_end (see 4.2.297), Section_interface (see 4.2.298), Security_classification (see 4.2.301), Security_level (see 4.2.302), Signal (see 4.2.309), Signal_value (see 4.2.313), Specification (see 4.2.323), Specification_category (see 4.2.324), Specification_expression (see 4.2.326), Specification_inclusion (see 4.2.327), Technical_system (see 4.2.336), Terminal (see 4.2.338), Work_order (see 4.2.364), or Work_request (see 4.2.365).

See 4.3.905, 4.3.906, 4.3.907, 4.3.908, 4.3.909, 4.3.910, 4.3.911, 4.3.912, 4.3.913, 4.3.914, 4.3.915, 4.3.916, 4.3.917, 4.3.918, 4.3.919, 4.3.920, 4.3.921, 4.3.922, 4.3.923, 4.3.924, 4.3.925, 4.3.926, 4.3.927, 4.3.928, 4.3.929, 4.3.934, 4.3.935, 4.3.936, 4.3.937, 4.3.938, 4.3.939, 4.3.940, 4.3.941, 4.3.942, 4.3.943, 4.3.944, 4.3.945, 4.3.946, 4.3.947, 4.3.948, 4.3.949, 4.3.950, 4.3.951, 4.3.952, 4.3.953, 4.3.954, 4.3.955, 4.3.956, 4.3.957, 4.3.958, 4.3.959, 4.3.960, 4.3.961, 4.3.962, 4.3.963, 4.3.964, 4.3.965, 4.3.966, 4.3.967, 4.3.968, 4.3.969, 4.3.970, 4.3.971, 4.3.972, 4.3.973, 4.3.974, 4.3.975, 4.3.976, 4.3.977, 4.3.978, 4.3.979, 4.3.980, 4.3.981, 4.3.982, 4.3.983, 4.3.984, 4.3.985, and 4.3.986 for the application assertions.

4.2.102.3 role

The role describes the relationship between the Document_version (see 4.2.114) and the associated item. The value is either user defined or predefined.

ISO 10303-212:2001(E)

The predefined value of role is one of the following:

- additional information;
- behaviour;
- catalogue;
- description;
- informative;
- mandatory;
- manual;
- mathematical description;
- specification.

NOTE See 4.2.102.3.1 - 4.2.102.3.9 for the definition of each predefined value for role.

4.2.102.3.1 additional information

additional information: The assigned document provides explanatory information.

4.2.102.3.2 behaviour

behaviour: The assigned document specifies information about the behaviour of the object specified by the 'is_assigned_to' attribute.

EXAMPLE State transition charts or flow diagrams can be used to provide information about the behaviour of an item.

4.2.102.3.3 catalogue

catalogue: The assigned document is the catalogue in which the object specified by the 'is_assigned_to' attribute is listed.

EXAMPLE The document can be the catalogue of the manufacturer.

4.2.102.3.4 description

description: The assigned document provides textual information about the object specified by the 'is_assigned_to' attribute.

4.2.102.3.5 informative

informative: The assigned document is for information only. It may or may not be considered.

4.2.102.3.6 mandatory

manual: The assigned element shall conform to the content of the assigned document.

4.2.102.3.7 mathematical description

mathematical description: The assigned document specifies the associated item by providing the algorithmic specification of its behaviour.

EXAMPLE The information can be used for simulation purposes.

4.2.102.3.8 specification

specification: The assigned document the considerations that led to the actual design of the object specified by the 'is_assigned_to' attribute.

4.2.103 Document_content_property

A Document_content_property specifies characteristics precisising the content of a Document_file (see 4.2.106) or of a Document_representation (see 4.2.110). At least one of the optional attributes shall be specified for each instance of this object.

In the case where a Document_content_property is referred by a Document_representation (see 4.2.110), the characteristics apply to all individual Document_file (see 4.2.106) objects, whereas in the case where it is referred by a Document_file (see 4.2.106), the characteristics apply on an individual basis.

The data associated with a Document_content_property are the following:

- detail_level;
- geometry_type;
- languages;
- real_world_scale.

4.2.103.1 detail_level

The detail_level specifies the level of detail that the Document_file (see 4.2.106) or the Document_representation (see 4.2.110) provides. The value is either user defined or predefined.

The predefined value of detail_level is one of the following:

- rough 3d shape;
- rounded edges.

NOTE See 4.2.103.1.1 - 4.2.103.1.2 for the definition of each predefined value for detail_level.

4.2.103.1.1 rough 3d shape

rough 3d shape: 3D shape model without edge rounds and fillets.

4.2.103.1.2 rounded edges

rounded edges: 3D shape model with edge rounds and fillets.

ISO 10303-212:2001(E)

The detail_level need not be specified for a particular Document_content_property.

4.2.103.2 geometry_type

The geometry_type specifies the kind or kinds of geometry that an object contains.

The value is either user defined or predefined.

The predefined value of detail_level is one of the following:

- 3D wireframe model;
- 2D shape;
- surface model;
- closed volume;
- solid model;
- solid and surface model;
- assembly;
- assembly with mating elements;
- 2D drawing;
- drawing derived from 3D data;
- drawing related to 3D data.

NOTE See 4.2.103.2.1 - 4.2.103.2.11 for the definition of each predefined value for detail_level.

4.2.103.2.1 3D wireframe model

3D wireframe model: The document contains a 3D shape model in wireframe representation.

4.2.103.2.2 2D shape

2D shape: The document contains a 2D shape model or contours only.

4.2.103.2.3 surface model

surface model: The document contains a 3D shape model in surface representation.

4.2.103.2.4 closed volume

closed volume: The document contains a 3D shape model in closed body topological surface representation.

4.2.103.2.5 solid model

solid model: The document contains a 3D shape model in advanced boundary representation.

4.2.103.2.6 solid and surface model

solid and surface model: The document contains a 3D shape model in surface and advanced boundary representation.

4.2.103.2.7 assembly

assembly: The document contains an assembly structure with reference to the assembled components and their transformation matrices.

4.2.103.2.8 assembly with mating elements

assembly with mating elements: The document contains an assembly structure including the mating components only, such as screws or rivets, with exact positioning information. This assembly representation is intended to be overlaid with the assembly structure for the main components.

4.2.103.2.9 2D drawing

2D drawing: The document contains a technical drawing without 3D shape representation.

4.2.103.2.10 drawing derived from 3D data

drawing derived from 3D data: : The document contains a technical drawing that has been derived from a 3D shape model.

4.2.103.2.11 drawing related to 3D data

drawing related to 3D data: : The document contains a technical drawing that visualizes a 3D shape model and possibly establishes associative links to the 3D shape model.

The `geometry_type` need not be specified for a particular `Document_content_property`.

4.2.103.3 languages

The `languages` specifies which language or languages are used in the characterized objects.

EXAMPLE 'Japanese' and 'German' are examples for the fact that annotation on a drawing is provided in the language 'Japanese' or 'German' respectively.

See 4.3.987 for the application assertion.

4.2.103.4 real_world_scale

The `real_world_scale` specifies the scale that is used in the `Document_file` (see 4.2.106) or in the `Document_representation` (see 4.2.110) the `Document_content_property` is referred by.

The `real_world_scale` need not be specified for a particular `Document_content_property`.

See 4.3.988 for the application assertion.

4.2.104 Document_creation_property

A Document_creation_property specifies characteristics of Document_file (see 4.2.106) or of Document_representation (see 4.2.110). It specifies the context of the creation of the object. At least one of the optional attributes shall be specified for each instance of this object.

In the case where a Document_creation_property is referred by a Document_representation (see 4.2.110) the characteristics apply to all individual Document_file (see 4.2.106) objects, whereas in the case it is referred by a Document_file (see 4.2.106), the characteristics apply on an individual basis.

The data associated with a Document_creation_property are the following:

- creating_interface;
- creating_system;
- operating_system.

4.2.104.1 creating_interface

The creating_interface specifies the computer application used to create the Document_file (see 4.2.106) or Document_representation (see 4.2.110) object.

EXAMPLE 1 'CATIGE V4.1.8' is an example for a creating interface of a Digital_document (see 4.2.91).

EXAMPLE 2 'Postscript Printer Driver' is an example for a creating interface of a Physical_document (see 4.2.242).

EXAMPLE 3 'SYSTEM-C-STL' is an example for a creating interface of a Physical_model (see 4.2.244) in the case of a stereolithographic model.

The creating_interface need not be specified for a particular Document_creation_property.

4.2.104.2 creating_system

The creating_system specifies the computer application or the machine which is used to create the object that is characterized.

4.2.104.3 operating_system

The operating_system specifies the operating system that is used to execute the computer application that created the characterized object.

The operating_system need not be specified for a particular Document_creation_property.

4.2.105 Document_designation

A Document_designation is a type of Object_designation (see 4.2.217) that is an identifier of a document.

EXAMPLE The title information of a document can be used as Document_designation.

4.2.106 Document_file

A Document_file is one of potentially more files on a computer system or in actual stacks of paper that make up a Document_representation (see 4.2.110).

Each Document_file is either a Digital_file (see 4.2.92) or a Hardcopy (see 4.2.166).

The data associated with a Document_file are the following:

- content;
- creation;
- description;
- document_file_type;
- external_id_and_location;
- file_format;
- id;
- size;
- version_id.

4.2.106.1 content

The content characterizes the content of the Document_file.

The content need not be specified for a particular Document_file.

See 4.3.989 for the application assertion.

4.2.106.2 creation

The creation specifies further details of the context of the creation of the Document_file.

The creation need not be specified for a particular Document_file.

See 4.3.990 for the application assertion.

4.2.106.3 description

The description specifies an alphanumeric string containing human-interpretable text that gives further details about the Document_file.

The description need not be specified for a particular Document_file.

4.2.106.4 document_file_type

The `document_file_type` specifies the format of the `Document_file`. It shall only be specified, if the `Document_file` does not participate in a `Document` (see 4.2.101).

The `document_file_type` need not be specified for a particular `Document_file`.

See 4.3.993 for the application assertion.

4.2.106.5 external_id_and_location

The `external_id_and_location` specifies alternatives of the identifier and location of the `Document_file`.

EXAMPLE A copy of a document may be found in another department with an different id.

See 4.3.994 for the application assertion.

4.2.106.6 file_format

The `file_format` specifies the characteristics of the `Document_file` that specify the format of the object.

The `file_format` need not be specified for a particular `Document_file`.

See 4.3.991 for the application assertion.

4.2.106.7 id

The `id` specifies the identifier which is used to locate the file either on a computer system or in a repository of paper documents.

4.2.106.8 size

The `size` specifies characteristics for the size of the `Document_file`.

The `size` need not be specified for a particular `Document_file`.

See 4.3.992 for the application assertion.

4.2.106.9 version_id

The `version_id` specifies the identification of the version that distinguishes one `Document_file` object from other versions of `Document_file` objects with the same `id`.

The `version_id` need not be specified for a particular `Document_file`.

4.2.107 Document_file_relationship

A Document_file_relationship is a relationship between two Document_file (see 4.2.106) objects. It specifies that the related Document_file (see 4.2.106) is referenced from the relating Document_file (see 4.2.106).

The data associated with a Document_file_relationship are the following:

- description;
- related;
- relating;
- relation_type.

4.2.107.1 description

The description specifies an alphanumeric string containing human-interpretable text that gives further details about the Document_file_relationship.

The description need not be specified for a particular Document_file_relationship.

4.2.107.2 related

The related specifies the second of the two Document_file (see 4.2.106) objects related by the Document_file_relationship.

See 4.3.995 for the application assertion.

4.2.107.3 relating

The relating specifies the first of the two Document_file (see 4.2.106) objects related by the Document_file_relationship.

See 4.3.996 for the application assertion.

4.2.107.4 relation_type

The relation_type specifies the meaning of the relationship. The value is either user defined or predefined.

ISO 10303-212:2001(E)

The predefined value of `relation_type` is one of the following:

- addition;
- copy;
- decomposition;
- derivation;
- peer;
- reference;
- sequence;
- substitution;
- translation.

NOTE See 4.2.107.4.1 - 4.2.107.4.8 for the definition of each predefined value for `relation_type`.

4.2.107.4.1 addition

addition: The `Document_file_relationship` specifies that the related document provides supplementary or collateral information with regard to the information provided by the relating document.

4.2.107.4.2 copy

copy: The `Document_file_relationship` defines a relationship where the related `Document_representation` (see 4.2.110) is a copy of the relating `Document_representation` (see 4.2.110).

4.2.107.4.3 decomposition

decomposition: The `Document_file_relationship` defines a relationship where the related `Document_representation` (see 4.2.110) is one of potentially more sub documents of the relating `Document_representation` (see 4.2.110).

4.2.107.4.4 derivation

derivation: The `Document_file_relationship` defines a relationship where the related `Document_representation` (see 4.2.110) is derived from the relating `Document_representation` (see 4.2.110).

4.2.107.4.5 reference

reference: The application object defines a relationship where the related document is referenced from the relating.

4.2.107.4.6 **sequence**

sequence: The Document_file_relationship defines a logical sequence where the related Document_representation (see 4.2.110) comes after the relating Document_representation (see 4.2.110) (e.g. a sequence of clauses).

4.2.107.4.7 **substitution**

substitution: The Document_file_relationship defines a relationship where the related Document_representation (see 4.2.110) replaces the relating Document_representation (see 4.2.110).

4.2.107.4.8 **translation**

translation: The Document_file_relationship specifies that the related document is generated through a translation process from the relating document.

4.2.108 Document_format_property

A Document_format_property specifies characteristics of a Document_file (see 4.2.106) or of a Document_representation (see 4.2.110) that specify the format of the object. At least one of the optional attributes shall be specified for each instance of this object.

In the case where a Document_format_property is referred by a Document_representation (see 4.2.110), the characteristics apply to all individual Document_file (see 4.2.106) objects, whereas in the case it is referred by a Document_file (see 4.2.106) the characteristics apply on an individual basis.

The data associated with a Document_representation (see 4.2.110) are the following:

- character_code;
- data_format;
- size_format.

4.2.108.1 **character_code**

The character_code specifies the character code that is used in the characterized object.

ISO 10303-212:2001(E)

The predefined value of `character_code` is one of the following:

- binary;
- IEC 61286;
- ISO 646;
- ISO 3098-1;
- ISO 6937;
- ISO 8859-1;
- ISO 10646.

NOTE 1 See 4.2.108.1.1 - 4.2.108.1.7 for the definition of each predefined value for `character_code`.

4.2.108.1.1 binary

binary: The document contains data in binary format.

4.2.108.1.2 IEC 61286

IEC 61286: The coded character set used to encode the document data according to IEC 61286.

4.2.108.1.3 ISO 646

ISO 646: The coded character set used to encode the document data according to ISO 646.

NOTE 2 The character set in ISO 646 is identical to the character set commonly known as ASCII.

4.2.108.1.4 ISO 3098-1

ISO 3098-1: The coded character set used to encode the document data is according to ISO 3098-1.

4.2.108.1.5 ISO 6937

IEC 61286: The coded character set used to encode the document data according to ISO/IEC 6937.

4.2.108.1.6 ISO 8859-1

ISO 8859-1: The coded character set used to encode the document data according to ISO 8859-1.

NOTE 3 The character set in ISO 8859-1 is identical to the character set commonly known as LATIN-1.

4.2.108.1.7 ISO 10646

ISO 10646: The coded character set used to encode the document data according to ISO/IEC 10646.

The character_code need not be specified for a particular Document_format_property.

4.2.108.2 data_format

The data_format specifies the convention that was used to structure the information in the characterized object.

The predefined value of data_format is one of the following:

- DXF;
- IGES;
- ISO 10303-203;
- ISO 10303-214;
- TIFF CCITT GR4.

NOTE 1 See 4.2.108.2.1 - 4.2.108.2.5 for the definition of each predefined value for data_format.

4.2.108.2.1 DXF

DXF: The document contains data in Drawing (see 4.2.119) Exchange File format.

4.2.108.2.2 IGES

IGES: The document contains data in Initial Graphics Exchange Specification (see 4.2.323) format.

4.2.108.2.3 ISO 10303-203

ISO 10303-203: The document contains data in ISO 10303-203 format.

4.2.108.2.4 ISO 10303-214

ISO 10303-214: The document contains data in ISO 10303-214 format.

4.2.108.2.5 VDAFS

VDAFS: The document contains data in VDAFS format.

The data_format need not be specified for a particular Document_format_property.

4.2.108.3 size_format

The size_format specifies the dimensions of a physical presentation of the object the size_format applies to.

EXAMPLE 1 'ISO A0' is an example for the size_format of a drawing that is stored digitally.

EXAMPLE 2 '0.2 x 0.4 x 0.4 meters' is an example for the size_format of a wooden model.

ISO 10303-212:2001(E)

See 4.3.997 for the application assertion.

4.2.109 Document_location_property

A Document_location_property specifies where a Document_file (see 4.2.106) or a Document_representation (see 4.2.110) can be found in a digital or physical data storage system. In the case where a Document_location_property is referred by a Document_representation (see 4.2.110), the characteristics apply to all individual objects, whereas in the case it is referred by a Document_file (see 4.2.106), the characteristics apply on an individual basis.

The data associated with a Document_location_property are the following:

— location_name

4.2.109.1 location_name

The location_name specifies the location, where the object, that refers to the Document_location_property, can be found.

NOTE Multiple paths may be specified for a single object, e.g., a database in the context of an electronic vault.

EXAMPLE The linking mechanism of many operating systems allows references to a single object from various places in the file system without copying its contents.

4.2.110 Document_representation

A Document_representation is used to specify a specific issue of a document.

Each Document_representation is either a Digital_document (see 4.2.91), a Physical_document (see 4.2.242), or a Physical_model (see 4.2.244).

The data associated with a Document_representation are the following:

- associated_document_version;
- common_location;
- content;
- creation;
- document_type;
- id;
- representation_format;
- size.

4.2.110.1 associated_document_version

The associated_document_version specifies the version of the logical document that is being represented.

See 4.3.1003 for the application assertion.

4.2.110.2 common_location

The common_location describes the location of a document.

NOTE Different common locations represent alternative representations of the same physical location.

See 4.3.1001 for the application assertion.

4.2.110.3 content

The content specifies characteristics of the content of the Document_representation.

The content need not be specified for a particular Document_representation.

See 4.3.998 for the application assertion.

4.2.110.4 creation

The creation specifies further details of the creation of the Document_representation.

The creation need not be specified for a particular Document_representation.

See 4.3.999 for the application assertion.

4.2.110.5 description

The description specifies an alphanumeric string containing human-interpretable text that gives further details about the Document_representation.

The description need not be specified for a particular Document_representation.

4.2.110.6 id

The id specifies the identifier of the Document_representation.

4.2.110.7 representation_format

The representation_format specifies the format of the document represented by Document_representation.

The representation_format need not be specified for a particular Document_representation.

See 4.3.1000 for the application assertion.

4.2.110.8 size

The size specifies the size of the represented document.

The size need not be specified for a particular Document_representation.

See 4.3.1002 for the application assertion.

4.2.111 Document_representation

A Document_representation (see 4.2.110) is used to specify a specific issue of a document.

The data associated with a Document_representation (see 4.2.110) are the following:

- associated_document_version;
- description;
- document_type;
- id.

4.2.111.1 associated_document_version

The associated_document_version specifies the Document_version (see 4.2.114).

4.2.111.2 description

The description specifies an alphanumeric string containing human-interpretable text that gives further details about the Document_representation (see 4.2.110).

4.2.111.3 document_type

The document_type specifies the kind of the document represented by Document_representation (see 4.2.110).

4.2.111.4 id

The id specifies the identifier of the Document_representation (see 4.2.110).

4.2.112 Document_size_property

A Document_size_property specifies the size of a Document_file (see 4.2.106) or of a Document_representation (see 4.2.110) object. At least one of the optional attributes shall be specified for each instance of this object.

In the case where a Document_size_property is referred by a Document_representation (see 4.2.110), the size information applies to the sum of all individual objects that are collected by this object, whereas in the case it is referred by a Document_file (see 4.2.106), the size information is the one of the individual objects that is referenced.

The data associated with a Document_size_property are the following:

- file_size;
- page_count.

4.2.112.1 file_size

The file_size specifies the Value_with_unit (see 4.2.360) that represents the size of a digitally stored document. The file_size shall only be applied in cases where the Document_size_property is referred by a Digital_document (see 4.2.91) or a Document_file (see 4.2.106).

EXAMPLE '15021 Bytes' and 'less than 500 Bytes' are examples for a file_size.

The file_size need not be specified for a particular Document_size_property.

See 4.3.1004 for the application assertion.

4.2.112.2 page_count

The page_count specifies the number of pages of the application object the Document_size_property referred by. The page_count shall only be used in cases where the Document_size_property is referred by a Hardcopy (see 4.2.166) or a Physical_document (see 4.2.242).

EXAMPLE 2 pages' and 'more than 1 page' are examples of a page_count.

The page_count need not be specified for a particular Document_size_property.

See 4.3.1005 for the application assertion.

4.2.113 Document_structure

ISO 10303-212:2001(E)

A Document_structure is the relation between two Document_representation (see 4.2.110) objects.

The data associated with an Document_structure are the following:

- description;
- related;
- relating;
- relation_type.

4.2.113.1 description

The description specifies an alphanumeric string containing human-interpretable text that gives further details about the Document_structure.

The description need not be specified for a particular Document_structure.

4.2.113.2 related

The related specifies the second of the two Document_representation (see 4.2.110) objects related by the Document_structure.

See 4.3.1006 for the application assertion.

4.2.113.3 relating

The relating specifies the first of the two Document_representation (see 4.2.110) objects related by the Document_structure.

See 4.3.1007 for the application assertion.

4.2.113.4 relation_type

The relation_type specifies the meaning of the relationship. The value is either user defined or predefined.

The predefined value of `relation_type` is one of the following:

- addition;
- copy;
- decomposition;
- derivation;
- peer;
- reference;
- sequence;
- substitution;
- translation.

NOTE See 4.2.113.4.1 - 4.2.113.4.8 for the definition of each predefined value for `relation_type`.

4.2.113.4.1 addition

addition: The `Document_structure` specifies that the related document provides supplementary or collateral information with regard to the information provided by the relating document.

4.2.113.4.2 copy

copy: The `Document_structure` defines a relationship where the related `Document_representation` (see 4.2.110) is a copy of the relating `Document_representation` (see 4.2.110).

4.2.113.4.3 decomposition

decomposition: The `Document_structure` defines a relationship where the related `Document_representation` (see 4.2.110) is one of potentially more sub documents of the relating `Document_representation` (see 4.2.110).

4.2.113.4.4 derivation

derivation: The `Document_structure` defines a relationship where the related `Document_representation` (see 4.2.110) is derived from the relating `Document_representation` (see 4.2.110).

EXAMPLE Documentation prepared for specific target groups of end users is derived from a set of master documents. The information content is a subset of the information contained in the master document and the layout is tailored to the needs of the target group.

4.2.113.4.5 reference

reference: The application object defines a relationship where the related document is referenced from the relating.

ISO 10303-212:2001(E)

4.2.113.4.6 sequence

sequence: The Document_structure defines a logical sequence where the related Document_representation (see 4.2.110) comes after the relating Document_representation (see 4.2.110) (e.g. a sequence of clauses).

4.2.113.4.7 substitution

substitution: The Document_structure defines a relationship where the related Document_representation (see 4.2.110) replaces the relating Document_representation (see 4.2.110).

4.2.113.4.8 translation

translation: The Document_structure specifies that the related document is generated through a translation process from the relating document.

4.2.114 Document_type_property

A Document_type_property specifies the kind of a Document_file (see 4.2.106).

The data associated with an Document_type_property are the following:

- document_type_name;
- used_classification_system.

4.2.114.1 document_type_name

The document_type_name specifies the word or the group of words that describe the kind of object the characteristics are provided for. The value is either user defined or predefined.

The predefined value of relation_type is one of the following:

- geometry;
- NC data;
- FE data;
- sample data;
- process plan;
- check plan;
- drawing.

NOTE See 4.2.114.1.1 - 4.2.114.1.8 for the definition of each predefined value for relation_type.

4.2.114.1.1 geometry

geometry: The document represents a shape model.

4.2.114.1.2 NC data

NC data: The document represents numerical control data.

4.2.114.1.3 FE data

FE data: The document represents numerical control data.

4.2.114.1.4 sample data

sample data: The document represents measured data.

4.2.114.1.5 process plan

process plan: The document represents process planning data.

4.2.114.1.6 check plan

check plan: The document represents quality control planning data.

4.2.114.1.7 drawing

drawing: The document represents a technical drawing.

4.2.114.2 used_classification_system

The `used_classification_system` specifies the `Classification_system` (see 4.2.48) the `document_type_` - name is defined in.

The `used_classification_system` need not be specified for a particular `Document_type_property`.

See 4.3.1008 for the application assertion.

4.2.115 Document_version

A `Document_version` specifies a particular variant of an `Document` (see 4.2.101).

NOTE Several versions for the same `Document` (see 4.2.101) may exist at one point in time. The information about valid and invalid versions is handled by the associated organizational data.

The data associated with an `Document_version` are the following:

- `associated_document`;
- description;
- id.

4.2.115.1 associated_document

The `associated_document` specifies the `Document` (see 4.2.101) to which the `Document_version` is assigned.

ISO 10303-212:2001(E)

See 4.3.1009 for the application assertion.

4.2.115.2 description

The description specifies an alphanumeric string containing human-interpretable text that gives further details about the Document_version.

The description need not be specified for a particular Document_version.

4.2.115.3 id

The id specifies the identifier of the Document_version.

4.2.116 Document_version_relationship

A Document_version_relationship is the relation between two Document_version (see 4.2.114) objects.

The data associated with an Document_version_relationship are the following:

- description;
- related;
- relating;
- relation_type.

4.2.116.1 description

The description specifies an alphanumeric string containing human-interpretable text that gives further details about the Document_version_relationship.

The description need not be specified for a particular Document_version_relationship.

4.2.116.2 related

The related specifies the second of the two Document_version (see 4.2.114) objects related by the Document_version_relationship.

See 4.3.1010 for the application assertion.

4.2.116.3 relating

The relating specifies the first of the two Document_version (see 4.2.114) objects related by the Document_version_relationship.

See 4.3.1011 for the application assertion.

4.2.116.4 relation_type

The `relation_type` specifies the meaning of the relationship. The value is either user defined or predefined.

The predefined value of `relation_type` is one of the following:

- derivation;
- hierarchy;
- sequence;
- supplied document.

NOTE See 4.2.116.4.1 - 4.2.116.4.4 for the definition of each predefined value for `relation_type`.

4.2.116.4.1 derivation

derivation: The `Document_version_relationship` defines a deriving relationship where the related `Document_version` (see 4.2.114) is based on the relating `Document_version` (see 4.2.114).

4.2.116.4.2 hierarchy

hierarchy: The `Document_version_relationship` defines a hierarchical relationship where the related `Document_version` (see 4.2.114) is a sub version of the relating `Document_version` (see 4.2.114).

EXAMPLE Revision 1.1 and 1.2 of a document.

4.2.116.4.3 sequence

sequence: The `Document_version_relationship` defines a succession of versions where the relating `Document_version` (see 4.2.114) is the preceding version and the related `Document_version` (see 4.2.114) is the following version. For a `Document_version` (see 4.2.114), there shall be, at the most, one `Document_version_relationship` of this relation type as relating and, at most, one `Document_version_relationship` of this relation type as related.

4.2.116.4.4 supplied document

supplied document: The `Document_version_relationship` defines a relationship where the related `Document_version` (see 4.2.114) is an alias for the relating `Document_version` (see 4.2.114). In this case the `Document` (see 4.2.101) objects associated with the two `Document_version` (see 4.2.114) objects shall be different.

4.2.117 Draughting_annotation

A `Draughting_annotation` is text and symbology applied to either a drawing sheet, drawing view, another piece of annotation, or a draughting model, for the purpose of communicating product data and drawing interpretation information.

Each `Draughting_annotation` is either an `Annotation_element` (see 4.2.15), an `Annotation_placed_annotation` (see 4.2.16), a `Dimension` (see 4.2.93), a `Draughting_callout` (see 4.2.117), a `Model_`

ISO 10303-212:2001(E)

placed_annotation (see 4.2.202), a Sheet_placed_annotation (see 4.2.308), or a View_placed_annotation (see 4.2.362).

4.2.118 Draughting_callout

A Draughting_callout is a type of Draughting_annotation (see 4.2.116) that is a combination of text, annotation curves, and symbology that conveys information about a specific feature or area.

Each Draughting_callout is either a Datum_feature_callout (see 4.2.83), a Datum_target_callout (see 4.2.84), or a Geometrical_tolerance (see 4.2.160).

The data associated with a Draughting_callout are the following:

- components.

4.2.118.1 components

The components specifies the text, curves, and symbols that compose the draughting callout.

Each components may be one of the following: Annotation_curve (see 4.2.14), Annotation_symbol (see 4.2.20), or Text (see 4.2.342).

See 4.3.1012, 4.3.1013, and 4.3.1014 for the application assertions.

4.2.119 Draughting_model

A Draughting_model is the aggregation of all those elements that, taken as a whole, make up a graphical description of the product data of an electrotechnical system or of its constituents.

The data associated with a Draughting_model are the following:

- coordinate_space;
- elements;
- name.

4.2.119.1 coordinate_space

The coordinate_space specifies the coordinate system that describes the two-dimensional space in which the content of the Draughting_model is located in.

See 4.3.1015 for the application assertion.

4.2.119.2 element

The element specifies the constituents of the Draughting_model.

See 4.3.1016 for the application assertion.

4.2.119.3 name

The name specifies the identifier of the Draughting_model.

4.2.120 Drawing

A Drawing is the presentation of product data in a human-interpretable form wherein the physical and functional requirements for that product are presented in pictorial or textual form.

The data associated with a Drawing are the following:

- drawing_specification;
- drawing_type;
- id;
- language_code;
- name;
- source;
- version_id.

4.2.120.1 drawing_specification

A drawing_specification specifies the identification of the standard to which the drawing conforms. This standard specifies the presentation forms used in the drawing.

EXAMPLE A drawing_specification can be ISO 129, Technical drawings – Dimensioning.

There shall be zero, one or more drawing_specification for a Drawing.

4.2.120.2 drawing_type

The drawing_type specifies the category of the Drawing and may indicate the information content.

EXAMPLE A drawing_type could be 'circuit diagram', 'terminal diagram', or 'arrangement drawing'.

4.2.120.3 extended_designation

The extended_designation specifies a structured label for the Drawing.

NOTE The label assigned through extended_designation shall be identical to the label assigned by the 'id' attribute.

The extended_designation need not be specified for a particular Drawing.

See 4.3.1017 for the application assertion.

4.2.120.4 id

ISO 10303-212:2001(E)

The id specifies the identifier of the Drawing.

4.2.120.5 language_code

The language_code specifies a language spoken by human beings to communicate with each other verbally or in written form. The language symbol given in ISO 639 shall be used.

There shall be zero, one or more language_code for a Drawing.

4.2.120.6 name

The name specifies a speaking designation of the Drawing.

The name need not be specified for a particular Drawing.

4.2.120.7 source

The source specifies from where the drawing can be procured.

The source need not be specified for a particular Drawing.

4.2.120.8 version_id

The version_id specifies versioning information for the Drawing.

4.2.121 Drawing_assignment

A Drawing_assignment is a relationship that associates a Drawing (see 4.2.119) with an item.

The data associated with a Drawing_assignment are the following:

- assigned_drawing;
- is_assigned_to.

4.2.121.1 assigned_drawing

The assigned_drawing specifies the Drawing (see 4.2.119).

See 4.3.1037 for the application assertion.

4.2.121.2 is_assigned_to

The is_assigned_to specifies the item with which the Drawing (see 4.2.119) is associated.

Each is_assigned_to may be one of the following: Activity (see 4.2.1), Address (see 4.2.6), Approval (see 4.2.23), Approval_status (see 4.2.25), Cable_pull_information (see 4.2.33), Class_category_association (see 4.2.40), Class_condition_association (see 4.2.41), Class_inclusion_association (see 4.2.42), Class_specification_association (see 4.2.44), Classification_attribute (see 4.2.47), Classification_system (see 4.2.48), Complex_product (see 4.2.51), Connectivity_definition (see 4.2.61), Contract (see 4.2.63), Data_element (see 4.2.70), Data_element_definition (see 4.2.72), Data_element_specification (see 4.2.75), Design_discipline_item_definition (see 4.2.86), Device (see

4.2.88), `Function_definition` (see 4.2.145), `Function_interface` (see 4.2.147), `Function_unit` (see 4.2.148), `Function_version` (see 4.2.150), `Functional_connectivity_definition` (see 4.2.152), `Functionality` (see 4.2.155), `General_classification` (see 4.2.156), `Generic_note` (see 4.2.159), `Interface` (see 4.2.170), `Interface_port` (see 4.2.171), `Interface_terminal` (see 4.2.174), `Item` (see 4.2.178), `Item_identification` (see 4.2.180), `Item_version` (see 4.2.182), `Location` (see 4.2.192), `Marking` (see 4.2.199), `Node` (see 4.2.208), `Notification` (see 4.2.213), `Object_designation` (see 4.2.217), `Organization` (see 4.2.223), `Path` (see 4.2.232), `Path_node` (see 4.2.233), `Person` (see 4.2.237), `Physical_assembly_relationship` (see 4.2.241), `Physical_instance` (see 4.2.243), `Port` (see 4.2.247), `Process_variable` (see 4.2.260), `Product_class` (see 4.2.263), `Product_identification` (see 4.2.268), `Project` (see 4.2.271), `Retention_period` (see 4.2.289), `Route` (see 4.2.290), `Section` (see 4.2.296), `Section_end` (see 4.2.297), `Section_interface` (see 4.2.298), `Security_classification` (see 4.2.301), `Security_level` (see 4.2.302), `Signal` (see 4.2.309), `Signal_value` (see 4.2.313), `Specification` (see 4.2.323), `Specification_category` (see 4.2.324), `Specification_expression` (see 4.2.326), `Specification_inclusion` (see 4.2.327), `Technical_system` (see 4.2.336), `Terminal` (see 4.2.338), `Work_order` (see 4.2.364), or `Work_request` (see 4.2.365).

See 4.3.1018, 4.3.1019, 4.3.1020, 4.3.1021, 4.3.1022, 4.3.1023, 4.3.1024, 4.3.1025, 4.3.1026, 4.3.1027, 4.3.1028, 4.3.1029, 4.3.1030, 4.3.1031, 4.3.1032, 4.3.1033, 4.3.1034, 4.3.1035, 4.3.1036, 4.3.1038, 4.3.1039, 4.3.1040, 4.3.1041, 4.3.1042, 4.3.1043, 4.3.1044, 4.3.1045, 4.3.1046, 4.3.1047, 4.3.1048, 4.3.1049, 4.3.1050, 4.3.1051, 4.3.1052, 4.3.1053, 4.3.1054, 4.3.1055, 4.3.1056, 4.3.1057, 4.3.1058, 4.3.1059, 4.3.1060, 4.3.1061, 4.3.1062, 4.3.1063, 4.3.1064, 4.3.1065, 4.3.1066, 4.3.1067, 4.3.1068, 4.3.1069, 4.3.1070, 4.3.1071, 4.3.1072, 4.3.1073, 4.3.1074, 4.3.1075, 4.3.1076, 4.3.1077, 4.3.1078, 4.3.1079, 4.3.1080, 4.3.1081, 4.3.1082, 4.3.1083, and 4.3.1084 for the application assertions.

4.2.122 `Drawing_sequence`

A `Drawing_sequence` is the relation between two `Drawing` (see 4.2.119) objects.

The data associated with a `Drawing_sequence` are the following:

- `following_version`;
- `preceding_version`.

4.2.122.1 `following_version`

The `following_version` specifies the `Drawing` (see 4.2.119) that supersedes the preceding version of the `Drawing` (see 4.2.119).

See 4.3.1085 for the application assertion.

4.2.122.2 `preceding_version`

The `preceding_version` specifies the `Drawing` (see 4.2.119) that is superseded through the `Drawing` (see 4.2.119) associated by the '`following_version`' attribute.

See 4.3.1086 for the application assertion.

4.2.123 Drawing_sheet

A Drawing_sheet is the logical division of a drawing into a two-dimensional area for the presentation of product data. These divisions correspond to sheet paper sizes for plotting. A Drawing_sheet contains at least one Drawing_view (see 4.2.125) or one Draughting_annotation (see 4.2.116).

The data associated with a Drawing_sheet are the following:

- associated_drawing;
- coordinate_space;
- extended_designation;
- id;
- name;
- orientation;
- sheet_number;
- size;
- version_id.

4.2.123.1 associated_drawing

The associated_drawing specifies the Drawing (see 4.2.119) that is valid for the Drawing_sheet.

See 4.3.1089 for the application assertion.

4.2.123.2 coordinate_space

The coordinate_space specifies the coordinate system that describes the two-dimensional space in which the content of the Drawing_sheet is located.

See 4.3.1087 for the application assertion.

4.2.123.3 extended_designation

The extended_designation specifies a structured label for the Drawing_sheet.

NOTE The label assigned through extended_designation shall be identical to the label assigned by the 'sheet_number' attribute.

The extended_designation need not be specified for a particular Drawing_sheet.

See 4.3.1088 for the application assertion.

4.2.123.4 name

The name specifies a speaking designation of the Drawing_sheet.

The name need not be specified for a particular Drawing_sheet.

4.2.123.5 orientation

The orientation specifies the alignment of the Drawing_sheet.

The value of orientation is one of the following:

— landscape;

— portrait.

NOTE See 4.2.123.5.1 - 4.2.123.5.2 for the definition of each predefined value for orientation.

4.2.123.5.1 landscape

landscape: The Drawing_sheet has a format where the width of the sheet is greater than the height.

4.2.123.5.2 portrait

portrait: The Drawing_sheet has a format where the height of the sheet is greater than the width.

4.2.123.6 sheet_number

The sheet_number specifies the page number for a particular drawing sheet and its location in relation to other sheets of the drawing.

The sheet_number need not be specified for a particular Drawing_sheet.

4.2.123.7 size

The size specifies the physical size of the presentation area of the drawing sheet. This physical size corresponds to the physical size of a sheet of paper on which the drawing sheet can be placed.

See 4.3.1090 for the application assertion.

4.2.123.8 version_id

The version_id specifies versioning information for the Drawing_sheet.

4.2.124 Drawing_sheet_layout

A Drawing_sheet_layout is a type of User_defined_symbol_definition (see 4.2.355) that is the arrangement of a sheet of a drawing.

4.2.125 Drawing_sheet_relationship

A Drawing_sheet_relationship is the relation between two Drawing_sheet (see 4.2.122) objects.

ISO 10303-212:2001(E)

The data associated with an `Drawing_sheet_relationship` are the following:

- `description`;
- `related`;
- `relating`;
- `relation_type`.

4.2.125.1 `description`

The `description` specifies an alphanumeric string containing human-interpretable text that gives further details about the `Drawing_sheet_relationship`.

The `description` need not be specified for a particular `Drawing_sheet_relationship`.

4.2.125.2 `related`

The `related` specifies the second of the two `Drawing_sheet` (see 4.2.122) objects related by the `Drawing_sheet_relationship`.

See 4.3.1091 for the application assertion.

4.2.125.3 `relating`

The `relating` specifies the first of the two `Drawing_sheet` (see 4.2.122) objects related by the `Drawing_sheet_relationship`.

See 4.3.1092 for the application assertion.

4.2.125.4 `relation_type`

The `relation_type` specifies the meaning of the relationship. The value is either user defined or predefined.

The predefined value of `relation_type` is one of the following:

- `derivation`;
- `substitution`;
- `translation`;
- `version hierarchy`;
- `version sequence`.

NOTE See 4.2.125.4.1 - 4.2.125.4.5 for the definition of each predefined value for `relation_type`.

4.2.125.4.1 `derivation`

derivation: The `Drawing_sheet_relationship` defines a deriving relationship where the related `Drawing_sheet` (see 4.2.122) is based on the relating `Drawing_sheet` (see 4.2.122).

4.2.125.4.2 substitution

substitution: The `Drawing_sheet_relationship` defines a relationship where the related `Drawing_sheet` (see 4.2.122) replaces the relating `Drawing_sheet` (see 4.2.122).

4.2.125.4.3 translation

translation: The `Drawing_sheet_relationship` defines a relationship where the related `Drawing_sheet` (see 4.2.122) is a transcription into another language of the relating `Drawing_sheet` (see 4.2.122).

4.2.125.4.4 version hierarchy

version hierarchy: The `Drawing_sheet_relationship` defines a hierarchical relationship where the related `Drawing_sheet` (see 4.2.122) is a subversion of the relating `Drawing_sheet` (see 4.2.122).

EXAMPLE Revision 1.1 and 1.2 of a drawing.

4.2.125.4.5 version sequence

version sequence: The `Drawing_sheet_relationship` defines a succession of versions where the relating `Drawing_sheet` (see 4.2.122) is the preceding version and the related `Drawing_sheet` (see 4.2.122) is the following version. For a `Drawing_sheet` (see 4.2.122) there shall be, at the most, one `Drawing_sheet_relationship` of this relation type as relating and, at most, one `Drawing_sheet_relationship` of this relation type as related.

4.2.126 Drawing_view

A `Drawing_view` is the set of instructions for producing a two-dimensional planar projection of a `Draughting_model` (see 4.2.118) from a specified position within its coordinate system.

ISO 10303-212:2001(E)

NOTE A `Drawing_view` may be placed multiple times on a drawing, but each is a separate `Drawing_view`. The placement within a particular `Drawing_sheet` (see 4.2.122) makes each `Drawing_view` unique to that `Drawing_sheet` (see 4.2.122).

The data associated with a `Drawing_view` are the following:

- `containing_sheet`;
- `coordinate_space`;
- `id`;
- `position`;
- `rotation`.

4.2.126.1 containing_sheet

The `containing_sheet` specifies the `Drawing_sheet` (see 4.2.122) object in which the `Drawing_view` is placed.

See 4.3.1094 for the application assertion.

4.2.126.2 coordinate_space

The `coordinate_space` specifies the `Cartesian_coordinate_space_2d` (see 4.2.34) in which the `Drawing_view` has been defined.

See 4.3.1093 for the application assertion.

4.2.126.3 id

The `id` specifies the identifier of the `Drawing_view`.

The `id` need not be specified for a particular `Drawing_view`.

4.2.126.4 position

The `position` specifies the location of the origin of the coordinate system of the `Drawing_view` relative to the origin of the coordinate system of the drawing sheet where it is placed.

See 4.3.1095 for the application assertion.

4.2.126.5 rotation

The `rotation` specifies the angle, measured counter-clockwise, between the horizontal axis of the coordinate system of the `Drawing_view` and the horizontal axis of the coordinate system of the `Drawing_sheet` (see 4.2.122) where it is placed.

4.2.127 Duration

A Duration is the definition of a period of time.

The data associated with an Effectivity (see 4.2.127) are the following:

- time;
- time_unit.

4.2.127.1 time

The time specifies the extend of the Duration.

4.2.127.2 time_unit

The time_unit specifies the unit in which the time is specified.

4.2.128 Effectivity

An Effectivity is the identification of the valid use of an aspect of product data tracked by date.

The data associated with an Effectivity are the following:

- concerned_organization;
- description;
- effectivity_context;
- end_definition;
- id;
- period;
- start_definition;
- version_id.

4.2.128.1 concerned_organization

The concerned_organization specifies the Organization (see 4.2.223) for which the Effectivity is valid.

EXAMPLE The Effectivity of the same item may be different in the various production sites of the manufacturer.

See 4.3.1101 for the application assertion.

4.2.128.2 description

The description specifies an alphanumeric string containing human-interpretable text that gives further details about the Effectivity.

ISO 10303-212:2001(E)

The description need not be specified for a particular Effectivity.

4.2.128.3 effectivity_context

The effectivity_context specifies the life-cycle stage for which the Effectivity is valid.

EXAMPLE The effectivity_context is 'prototype building' in order to express that the Effectivity is valid for this life-cycle stage of the concerned item.

The effectivity_context need not be specified for a particular Effectivity.

4.2.128.4 end_definition

The end_definition specifies the date, event, or period of time after the start_definition or after an event when the identified item is no longer effective.

The end_definition need not be specified for a particular Effectivity.

Each end_definition may be one of the following: Date_time (see 4.2.79) or Event_reference (see 4.2.130).

See 4.3.1096 and 4.3.1099 for the application assertions.

4.2.128.5 id

The id specifies the identifier of the Effectivity.

The id need not be specified for a particular Effectivity.

4.2.128.6 period

The period specifies the period of time in which the Effectivity is valid, starting at the point in time specified by either 'start_definition' or 'end_definition'.

The period need not be specified for a particular Effectivity.

See 4.3.1098 for the application assertion.

4.2.128.7 start_definition

The start_definition specifies the date or the event when the identified item becomes effective.

The start_definition need not be specified for a particular Effectivity.

Each start_definition may be one of the following: Date_time (see 4.2.79) or Event_reference (see 4.2.130).

See 4.3.1097 and 4.3.1100 for the application assertions.

4.2.128.8 version_id

The version_id specifies versioning information for the Effectivity.

The `version_id` need not be specified for a particular Effectivity.

4.2.129 Effectivity_assignment

An Effectivity_assignment associates an Effectivity (see 4.2.127) with an item, where the effectivity of the item is controlled by the associated Effectivity (see 4.2.127).

The data associated with an Effectivity_assignment are the following:

- `assigned_effectivity`;
- `effectivity_indication`;
- `is_applied_to`;
- `role`.

4.2.129.1 assigned_effectivity

The `assigned_effectivity` specifies the Effectivity (see 4.2.127) object.

See 4.3.1136 for the application assertion.

4.2.129.2 effectivity_indication

The `effectivity_indication` specifies whether the Effectivity_assignment takes effect. A value of 'true' indicates that the Effectivity_assignment is effective, a value of 'false' that the Effectivity_assignment is ineffective.

4.2.129.3 is_applied_to

The `is_applied_to` specifies the item with which the Effectivity (see 4.2.127) object is associated.

Each `is_applied_to` may be one of the following: Activity_relationship (see 4.2.5), Alternate_item_relationship (see 4.2.11), Assembly_component_relationship (see 4.2.26), Assembly_substitute_relationship (see 4.2.28), Cable_pull_information (see 4.2.33), Class_category_association (see 4.2.40), Class_condition_association (see 4.2.41), Class_inclusion_association (see 4.2.42), Class_specification_association (see 4.2.44), Class_structure_relationship (see 4.2.45), Classification_system (see 4.2.48), Complex_product (see 4.2.51), Complex_product_relationship (see 4.2.52), Composition_relationship (see 4.2.55), Configuration (see 4.2.56), Connectivity_definition (see 4.2.61), Connectivity_definition_relationship (see 4.2.62), Data_element (see 4.2.70), Data_element_association (see 4.2.71), Data_element_definition (see 4.2.72), Data_element_relationship (see 4.2.74), Design_discipline_item_definition (see 4.2.86), Device (see 4.2.88), Device_relationship (see 4.2.89), Document (see 4.2.101), Document_file (see 4.2.106), Document_file_relationship (see 4.2.107), Document_representation (see 4.2.110), Document_version (see 4.2.114), Document_version_relationship (see 4.2.115), Drawing (see 4.2.119), Drawing_sequence (see 4.2.121), Drawing_sheet (see 4.2.122), Drawing_sheet_relationship (see 4.2.124), Function_definition (see 4.2.145), Function_definition_relationship (see 4.2.146), Function_interface (see 4.2.147), Function_unit (see 4.2.148), Function_unit_relationship (see 4.2.149), Function_version (see 4.2.150), Function_version_relationship (see 4.2.151), Functional_connectivity_definition (see 4.2.152), Functional_connectivity_definition_relationship (see 4.2.153), Generic_note (see 4.2.159), Interface (see 4.2.170), Interface_port (see 4.2.171), Interface_terminal (see 4.2.174), Item (see

ISO 10303-212:2001(E)

4.2.178), `Item_definition_relationship` (see 4.2.179), `Item_version` (see 4.2.182), `Item_version_relationship` (see 4.2.183), `Location` (see 4.2.192), `Location_relationship` (see 4.2.194), `Marking` (see 4.2.199), `Node` (see 4.2.208), `Node_relationship` (see 4.2.209), `Notification` (see 4.2.213), `Notification_relationship` (see 4.2.214), `Path` (see 4.2.232), `Path_node` (see 4.2.233), `Path_node_relationship` (see 4.2.234), `Path_relationship` (see 4.2.235), `Physical_assembly_relationship` (see 4.2.241), `Physical_instance` (see 4.2.243), `Port` (see 4.2.247), `Process_variable` (see 4.2.260), `Process_variable_relationship` (see 4.2.261), `Product_class` (see 4.2.263), `Product_identification` (see 4.2.268), `Product_structure_relationship` (see 4.2.270), `Requirement` (see 4.2.285), `Route` (see 4.2.290), `Route_relationship` (see 4.2.291), `Section` (see 4.2.296), `Section_end` (see 4.2.297), `Section_interface` (see 4.2.298), `Section_interface_relationship` (see 4.2.299), `Section_relationship` (see 4.2.300), `Security_classification` (see 4.2.301), `Signal` (see 4.2.309), `Signal_relationship` (see 4.2.311), `Signal_value` (see 4.2.313), `Specification` (see 4.2.323), `Specification_category` (see 4.2.324), `Specification_expression` (see 4.2.326), `Specification_inclusion` (see 4.2.327), `Technical_system` (see 4.2.336), `Technical_system_relationship` (see 4.2.337), or `Terminal` (see 4.2.338).

See 4.3.1102, 4.3.1103, 4.3.1104, 4.3.1105, 4.3.1106, 4.3.1107, 4.3.1108, 4.3.1109, 4.3.1110, 4.3.1111, 4.3.1112, 4.3.1113, 4.3.1114, 4.3.1115, 4.3.1116, 4.3.1117, 4.3.1118, 4.3.1119, 4.3.1120, 4.3.1121, 4.3.1122, 4.3.1123, 4.3.1124, 4.3.1125, 4.3.1126, 4.3.1127, 4.3.1128, 4.3.1129, 4.3.1130, 4.3.1131, 4.3.1132, 4.3.1133, 4.3.1134, 4.3.1135, 4.3.1137, 4.3.1138, 4.3.1139, 4.3.1140, 4.3.1141, 4.3.1142, 4.3.1143, 4.3.1144, 4.3.1145, 4.3.1146, 4.3.1147, 4.3.1148, 4.3.1149, 4.3.1150, 4.3.1151, 4.3.1152, 4.3.1153, 4.3.1154, 4.3.1155, 4.3.1156, 4.3.1157, 4.3.1158, 4.3.1159, 4.3.1160, 4.3.1161, 4.3.1162, 4.3.1163, 4.3.1164, 4.3.1165, 4.3.1166, 4.3.1167, 4.3.1168, 4.3.1169, 4.3.1170, 4.3.1171, 4.3.1172, 4.3.1173, 4.3.1174, 4.3.1175, 4.3.1176, 4.3.1177, 4.3.1178, 4.3.1179, 4.3.1180, 4.3.1181, 4.3.1182, 4.3.1183, 4.3.1184, 4.3.1185, 4.3.1186, 4.3.1187, 4.3.1188, 4.3.1189, 4.3.1190, and 4.3.1191 for the application assertions.

4.2.129.4 role

The role specifies the relationship between the Effectivity (see 4.2.127) and the item that has an effectivity assigned to it. The value is either user defined or predefined.

The predefined value of role is one of the following:

- actual;
- planned;
- required.

NOTE See 4.2.129.4.1 - 4.2.129.4.3 for the definition of each predefined value for relation_type.

4.2.129.4.1 actual

actual: The actual period during which the Effectivity (see 4.2.127) lasted.

4.2.129.4.2 planned

planned: The period associated with the Effectivity (see 4.2.127) defines a planned period of time during which the associated object is or was supposed to be effective.

4.2.129.4.3 required

required: The associated object must be kept effective for this period.

4.2.130 Effectivity_relationship

An Effectivity_relationship is the relation between two Effectivity (see 4.2.127) objects.

NOTE Sometimes the effectivity is not dependent on particular dates but on the effectivity of other items. In this case, the dates are not instantiated, and an Effectivity (see 4.2.127) relationship to the reference Effectivity (see 4.2.127) exists.

The data associated with an Effectivity_relationship are the following:

- description;
- related;
- relating;
- relation_type.

4.2.130.1 description

The description specifies an alphanumeric string containing human-interpretable text that gives further details about the Effectivity_relationship.

The description need not be specified for a particular Effectivity_relationship.

4.2.130.2 related

The related specifies the second of the two Effectivity (see 4.2.127) objects related by the Effectivity_relationship.

See 4.3.1192 for the application assertion.

4.2.130.3 relating

The relating specifies the first of the two Effectivity (see 4.2.127) objects related by the Effectivity_relationship.

See 4.3.1193 for the application assertion.

4.2.130.4 relation_type

The relation_type specifies the meaning of the relationship. The value is either user defined or predefined.

ISO 10303-212:2001(E)

The predefined value of `relation_type` is one of the following:

- constraint;
- inheritance.

NOTE See 4.2.130.4.1 - 4.2.130.4.2 for the definition of each predefined value for `relation_type`.

4.2.130.4.1 constraint

constraint: The time period between the start and end definition of the related Effectivity (see 4.2.127) shall be within the time period of the relating Effectivity (see 4.2.127).

4.2.130.4.2 inheritance

inheritance: The related Effectivity (see 4.2.127) shall not have a 'start definition' and 'end definition' specified but inherits the effectivity dates from the relating Effectivity (see 4.2.127).

4.2.131 Event_reference

An `Event_reference` is the definition of a point in time established with respect to an event.

The data associated with an `Event_reference` are the following:

- description;
- `event_context`;
- `event_type`;
- offset.

4.2.131.1 description

The description specifies an alphanumeric string containing human-interpretable text that gives further details about the `Event_reference`.

The description need not be specified for a particular `Event_reference`.

4.2.131.2 event_context

The `event_context` specifies the piece of product data the `Event_reference` refers to.

EXAMPLE In the case of an `Event_reference` with event type 'start of production', the event context would refer to the `Item_version` (see 4.2.182) that is subject to production.

The `event_context` need not be specified for a particular `Event_reference`.

Each `event_context` may be one of the following: `Activity` (see 4.2.1), `Activity_element` (see 4.2.2), `Activity_method_assignment` (see 4.2.4), `Activity_relationship` (see 4.2.5), `Alternate_item_relationship` (see 4.2.11), `Approval_status` (see 4.2.25), `Assembly_component_relationship` (see 4.2.26), `Assembly_substitute_relationship` (see 4.2.28), `Cable_pull_information` (see 4.2.33),

Certification (see 4.2.38), Class_category_association (see 4.2.40), Class_condition_association (see 4.2.41), Class_inclusion_association (see 4.2.42), Class_specification_association (see 4.2.44), Class_structure_relationship (see 4.2.45), Classification_association (see 4.2.46), Classification_attribute (see 4.2.47), Classification_system (see 4.2.48), Complex_product (see 4.2.51), Complex_product_relationship (see 4.2.52), Composition_relationship (see 4.2.55), Configuration (see 4.2.56), Connectivity_allocation (see 4.2.60), Connectivity_definition (see 4.2.61), Connectivity_definition_relationship (see 4.2.62), Contract (see 4.2.63), Data_element (see 4.2.70), Data_element_association (see 4.2.71), Data_element_definition (see 4.2.72), Data_element_relationship (see 4.2.74), Data_element_specification (see 4.2.75), Design_discipline_item_definition (see 4.2.86), Device (see 4.2.88), Device_relationship (see 4.2.89), Document (see 4.2.101), Document_file (see 4.2.106), Document_file_relationship (see 4.2.107), Document_representation (see 4.2.110), Document_version (see 4.2.114), Document_version_relationship (see 4.2.115), Drawing (see 4.2.119), Drawing_sequence (see 4.2.121), Drawing_sheet (see 4.2.122), Drawing_sheet_relationship (see 4.2.124), Free_segment (see 4.2.144), Function_definition (see 4.2.145), Function_definition_relationship (see 4.2.146), Function_interface (see 4.2.147), Function_unit (see 4.2.148), Function_unit_relationship (see 4.2.149), Function_version (see 4.2.150), Function_version_relationship (see 4.2.151), Functional_connectivity_definition (see 4.2.152), Functional_connectivity_definition_relationship (see 4.2.153), Functional_unit_allocation (see 4.2.154), Functionality (see 4.2.155), General_classification (see 4.2.156), Generic_note (see 4.2.159), Interface (see 4.2.170), Interface_port (see 4.2.171), Interface_terminal (see 4.2.174), Item (see 4.2.178), Item_definition_relationship (see 4.2.179), Item_version (see 4.2.182), Item_version_relationship (see 4.2.183), Location (see 4.2.192), Location_relationship (see 4.2.194), Marking (see 4.2.199), Material (see 4.2.201), Node (see 4.2.208), Node_relationship (see 4.2.209), Notification (see 4.2.213), Notification_relationship (see 4.2.214), Offered_function_allocation (see 4.2.220), Organization_relationship (see 4.2.225), Path (see 4.2.232), Path_node (see 4.2.233), Path_node_relationship (see 4.2.234), Path_relationship (see 4.2.235), Person_in_organization (see 4.2.238), Person_in_organization_relationship (see 4.2.239), Physical_assembly_relationship (see 4.2.241), Physical_instance (see 4.2.243), Port (see 4.2.247), Port_allocation (see 4.2.248), Port_association (see 4.2.249), Preferred_item_allocation (see 4.2.258), Preferred_item_terminal_allocation (see 4.2.259), Process_variable (see 4.2.260), Process_variable_relationship (see 4.2.261), Product_class (see 4.2.263), Product_identification (see 4.2.268), Product_structure_relationship (see 4.2.270), Project (see 4.2.271), Requirement (see 4.2.285), Requirement_document_assignment (see 4.2.287), Route (see 4.2.290), Route_relationship (see 4.2.291), Routed_segment (see 4.2.293), Section (see 4.2.296), Section_end (see 4.2.297), Section_interface (see 4.2.298), Section_interface_relationship (see 4.2.299), Section_relationship (see 4.2.300), Security_classification (see 4.2.301), Security_level (see 4.2.302), Signal (see 4.2.309), Signal_relationship (see 4.2.311), Signal_value (see 4.2.313), Specification (see 4.2.323), Specification_category (see 4.2.324), Specification_expression (see 4.2.326), Specification_inclusion (see 4.2.327), Technical_system (see 4.2.336), Technical_system_relationship (see 4.2.337), Terminal (see 4.2.338), Work_order (see 4.2.364), or Work_request (see 4.2.365).

See 4.3.1194, 4.3.1195, 4.3.1196, 4.3.1197, 4.3.1198, 4.3.1199, 4.3.1200, 4.3.1201, 4.3.1202, 4.3.1203, 4.3.1204, 4.3.1205, 4.3.1206, 4.3.1207, 4.3.1208, 4.3.1209, 4.3.1210, 4.3.1211, 4.3.1212, 4.3.1213, 4.3.1214, 4.3.1215, 4.3.1216, 4.3.1217, 4.3.1218, 4.3.1219, 4.3.1220, 4.3.1221, 4.3.1222, 4.3.1223, 4.3.1224, 4.3.1225, 4.3.1226, 4.3.1227, 4.3.1228, 4.3.1229, 4.3.1230, 4.3.1231, 4.3.1232, 4.3.1233, 4.3.1234, 4.3.1235, 4.3.1236, 4.3.1237, 4.3.1239, 4.3.1240, 4.3.1241, 4.3.1242, 4.3.1243, 4.3.1244, 4.3.1245, 4.3.1246, 4.3.1247, 4.3.1248, 4.3.1249, 4.3.1250, 4.3.1251, 4.3.1252, 4.3.1253, 4.3.1254, 4.3.1255, 4.3.1256, 4.3.1257, 4.3.1258, 4.3.1259, 4.3.1260, 4.3.1261, 4.3.1262, 4.3.1263, 4.3.1264, 4.3.1265, 4.3.1266, 4.3.1267, 4.3.1268, 4.3.1269, 4.3.1270, 4.3.1271, 4.3.1272, 4.3.1273, 4.3.1274, 4.3.1275, 4.3.1276, 4.3.1277, 4.3.1278, 4.3.1279, 4.3.1280, 4.3.1281, 4.3.1282, 4.3.1283,

ISO 10303-212:2001(E)

4.3.1284, 4.3.1285, 4.3.1286, 4.3.1287, 4.3.1288, 4.3.1289, 4.3.1290, 4.3.1291, 4.3.1292, 4.3.1293, 4.3.1294, 4.3.1295, 4.3.1296, 4.3.1297, 4.3.1298, 4.3.1299, 4.3.1300, 4.3.1301, 4.3.1302, 4.3.1303, 4.3.1304, 4.3.1305, 4.3.1306, 4.3.1307, 4.3.1308, 4.3.1309, 4.3.1310, 4.3.1311, and 4.3.1312 for the application assertions.

4.2.131.3 event_type

The event_type specifies the kind of event that serves as reference.

EXAMPLE The cases 'start of production' or 'end of production' are examples for the event_type.

4.2.131.4 offset

The offset specifies the amount of time before or after the defined event that shall be used to calculate the actual point in time.

The offset need not be specified for a particular Event_reference.

See 4.3.1238 for the application assertion.

4.2.132 External_file_id_and_location

An External_file_id_and_location specifies the location of an file in an external storage system.

The data associated with an External_file_id_and_location are the following:

- external_id;
- location.

4.2.132.1 external_id

The external_id specifies the identifier of an document in the external location.

4.2.132.2 location

The location specifies the location of the Document_file (see 4.2.106) in the external storage system.

See 4.3.1313 for the application assertion.

4.2.133 External_library_reference

An External_library_reference is a mechanism to refer to an entry in an external library other than ISO 13584 or IEC 61360.

The data associated with an `External_library_reference` are the following:

- `description`;
- `external_id`;
- `library_type`.

4.2.133.1 description

The `description` specifies an alphanumeric string containing human-interpretable text that gives further details about the `External_library_reference`.

The `description` need not be specified for a particular `External_library_reference`.

4.2.133.2 external_id

The `external_id` specifies the unique identifier of the referenced entry in the external library.

4.2.133.3 library_type

The `library_type` specifies the type of library that is used.

4.2.134 Externally_defined_hatching

An `Externally_defined_hatching` is a type of `Fill_area_appearance` (see 4.2.140) that has a specific physical appearance defining the hatching and is found in a known source. This known source is agreed to by all parties involved in the exchange of the drawings on which the hatching pattern appears. The specific appearance is referred to as a hatch pattern and consists of a curve appearance and the angle and displacement values necessary to define a single, uniformly spaced geometric pattern. An `Externally_defined_hatching` shall include the specification of the curve appearance, the angle of the curves in the pattern relative to the horizontal axis of the coordinate system into which it is placed, and the displacement between adjacent curves in the pattern.

The data associated with an `Externally_defined_hatching` are the following:

- `hatching_name`;
- `hatching_reference`.

4.2.134.1 hatching_name

The `hatching_name` specifies the identification of a particular hatching pattern within the known source.

4.2.134.2 hatching_reference

The `hatching_reference` specifies the known source that contains a set of patterns from which the hatching pattern is selected.

4.2.135 Externally_defined_line_font

ISO 10303-212:2001(E)

An `Externally_defined_line_font` is a type of `Line_font` (see 4.2.189) that has a specific physical appearance defining the line font and is found in a known source. This known source is agreed to by all parties involved in the exchange of the drawings on which the line font appears. An `Externally_defined_line_font` shall include a set of values that represent the length of the visible and invisible segments of the line font. The set of values is sufficient to define all elements that constitute a single portion of the curve. This portion is then repeated over the length of the curve.

The data associated with an `Externally_defined_line_font` are the following:

- `font_id`;
- `font_reference`.

4.2.135.1 `font_id`

The `font_id` specifies the identification of a particular line font within the known source.

4.2.135.2 `font_reference`

The `font_reference` specifies the known source that contains a set of line fonts from which the line font is selected.

4.2.136 `Externally_defined_symbol`

An `Externally_defined_symbol` is a type of `Annotation_symbol` (see 4.2.20) that has a specific physical appearance defining the symbol and is found in a known source. This known source is agreed to by all parties involved in the exchange of the drawings on which the symbol appears. An `Externally_defined_symbol` shall include the specification of all the constituent components of the symbol, their size, and relative locations.

EXAMPLE IEC 60617 and IEC 81714 specify the layout of graphical symbols for use in diagrams.

The data associated with an `Externally_defined_symbol` are the following:

- `symbol_name`;
- `symbol_reference`.

4.2.136.1 `symbol_name`

The `symbol_name` specifies the identification of a particular symbol within the known source.

4.2.136.2 `symbol_reference`

The `symbol_reference` specifies the known source that contains a set of symbols from which the symbol is selected.

4.2.137 `Externally_defined_text_font`

An `Externally_defined_text_font` is a type of `Text_font` (see 4.2.344) that has a specific physical appearance defining the text font and is found in a known source. This known source is agreed to by

all parties involved in the exchange of the drawings on which the text font appears. An `Externally_defined_text_font` shall include the specification of the physical form of the characters of the font.

The data associated with an `Externally_defined_text_font` are the following:

- `font_id`;
- `font_reference`.

4.2.137.1 font_id

The `font_id` specifies the identification of a particular text font within the known source.

4.2.137.2 font_reference

The `font_reference` specifies the known source that contains a set of text fonts from which the text font is selected.

4.2.138 Externally_defined_tile

An `Externally_defined_tile` is a type of `Tile` (see 4.2.346) that has a specific physical appearance defining the tile and is found in a known source. This known source is agreed to by all parties involved in the exchange of the drawings on which the tile appears.

The data associated with an `Externally_defined_tile` are the following:

- `tile_name`;
- `tile_reference`.

4.2.138.1 tile_name

The `tile_name` specifies the identification of a particular tile within the known source.

4.2.138.2 tile_reference

The `tile_reference` specifies the known source that contains a set of tiles from which the tile is selected.

4.2.139 Externally_defined_tiling

An `Externally_defined_tiling` is a type of `Fill_area_appearance` (see 4.2.140) that has a specific physical appearance defining the tiling pattern and is found in a known source. This known source is agreed to by all parties involved in the exchange of the drawings on which the tiling appears. An `Externally_defined_tiling` shall include the repeat vectors used to define the relative positioning of tiles, the angle of the horizontal axis of the tile relative to the horizontal axis of the coordinate system into which it is placed, and the scale of the tile as presented to the tile as defined.

ISO 10303-212:2001(E)

The data associated with an `Externally_defined_tiling` are the following:

- `tiling_name`;
- `tiling_reference`.

4.2.139.1 `tiling_name`

The `tiling_name` specifies the identification of a particular tiling patterns within the known source.

4.2.139.2 `tiling_reference`

The `tiling_reference` specifies the known source that contains a set of pattern from which the tiling pattern is selected.

4.2.140 `Fill_area`

A `Fill_area` is a type of `Annotation_element` (see 4.2.15) that is a bounded area containing colouring, hatching, or tiling that indicate its extent and content. A `Fill_area` communicates some aspect of a physical part characteristic, distinguishes some aspect of a physical part from its surroundings, is part of another piece of annotation, or is used as an annotation by itself.

NOTE `Fill_areas` are derived from geometric elements, annotation curves, or a combination of both. The two types of curves can be combined if the geometric elements do not result in a closed boundary necessary for the confinement of the filled area. Only those annotation curves used for geometric construction can be included in the boundary of a `fill_area`.

The data associated with a `Fill_area` are the following:

- `assigned_appearance`;
- `bounds`;
- `reference_point`.

4.2.140.1 `assigned_appearance`

The `assigned_appearance` specifies the definition of the appearance characteristics of the `Fill_area`.

See 4.3.1314 for the application assertion.

4.2.140.2 `boundary`

The `boundary` specifies the outline of an `Fill_area`.

See 4.3.1315 for the application assertion.

4.2.140.3 `reference_point`

The `reference_point` specifies a point within the fill area used in the placement and initiation of the fill area appearance. The `reference_point` establishes a point through which a line of a hatching pattern passes or at which the origin of a tile is located. The `reference_point` also establishes the point

at which the first visible segment of a line font used as the curve appearance for a hatching pattern starts.

The reference_point need not be specified for a particular Fill_area.

See 4.3.1316 for the application assertion.

4.2.141 Fill_area_appearance

A Fill_area_appearance is a type of Appearance (see 4.2.21) that governs the visual presentation of a fill area.

Each Fill_area_appearance is either an Externally_defined_hatching (see 4.2.133), an Externally_defined_tiling (see 4.2.138), a Solid_fill_area (see 4.2.317), a User_defined_hatching (see 4.2.352), or a User_defined_tiling (see 4.2.357).

The data associated with a Fill_area_appearance are the following:

- draughting_role.

4.2.141.1 draughting_role

The draughting_role specifies the purpose within draughting for a particular fill area appearance.

The draughting_role need not be specified for a particular Fill_area_appearance.

4.2.142 Fill_area_boundary

A Fill_area_boundary is an annotation curve in the same coordinate space that defines the limits of a fill area. The curve is closed and not self intersecting. In a three-dimensional fill area, the curve either forms a closed curve on a planar surface or is coincident with the boundary of a closed surface.

NOTE The curves composing the Fill_area_boundary are derived from, and coincide with, the geometric curves or surfaces and the annotation curves that define the extent of the fill area.

The data associated with a Fill_area_boundary are the following:

- defining_curve.

4.2.142.1 defining_curve

The defining_curve specifies the annotation curve that defines the boundary of the fill area.

See 4.3.1317 for the application assertion.

4.2.143 Final_solution

A Final_solution is a type of Alternative_solution (see 4.2.12) that is the specification of a set of items that fulfil the same functional requirements as the neutral base element and have additional characteristics.

EXAMPLE The neutral parts are parts without paint; the final parts are the parts with paint.

ISO 10303-212:2001(E)

The data associated with a `Final_solution` are the following:

- `final_specification`;
- `final_status`.

4.2.143.1 `final_specification`

The `final_specification` specifies the means of finalization that is applied to the neutral part.

EXAMPLE The `final_specification` can be the `Design_discipline_item_definition` (see 4.2.86) of a certain kind of paint.

NOTE The `Design_discipline_item_definition` (see 4.2.86) that is referenced here is not a view of the equipment that results from the finalization. The resulting, coloured devices can be identified by the `Device` (see 4.2.88) objects that are associated with the `Final_solution`.

Each `final_specification` may be one of the following: `Descriptive_specification` (see 4.2.85), `Design_discipline_item_definition` (see 4.2.86), `Function_definition` (see 4.2.145), or `Physical_instance` (see 4.2.243).

See 4.3.1318, 4.3.1319, 4.3.1320, and 4.3.1321 for the application assertions.

4.2.143.2 `final_status`

The `final_status` specifies the level of completion between the neutral part and the final part.

EXAMPLE The status information 'final for shipping overseas', 'final for transport by truck', or 'final for sale' are examples for the `final_status`.

4.2.144 `Format_of_value`

A `Format_of_value` is the specification of the syntactical format of a value. If present, the '`value_of_single_value`' attribute of the corresponding `Single_value` (see 4.2.316) object shall contain only data that conform with the `Format_of_value` object.

The data associated with a `Format_of_value` are the following:

- `associated_definition`;
- `default_language_specification`;
- `source_document`;
- `value_format`.

4.2.144.1 `associated_definition`

The `associated_definition` specifies the appropriate `Data_element_definition` (see 4.2.72).

See 4.3.1322 for the application assertion.

4.2.144.2 default_language_specification

The default_language_specification specifies a language spoken by human beings to communicate with each other verbally or in written form. This language is the preselected language used in the associated String_value (see 4.2.331) object. The language symbol given in ISO 639 shall be used.

The default_language_specification need not be specified for a particular Format_of_value.

See 4.3.1323 for the application assertion.

4.2.144.3 source_document

The source_document specifies the identifier of the document in which the value_format is specified. The value is either user defined or predefined.

The predefined value of source_document is the following:

— iec 61360.

NOTE See 4.2.144.3.1 for the definition of each predefined value for source_document.

4.2.144.3.1 iec 61360

iec 61360: The value_format is in accordance with IEC 61360.

4.2.144.4 value_format

The value_format specifies the syntactical format of the value that is associated to the appropriate Data_element_definition (see 4.2.72) object.

4.2.145 Free_segment

A Free_segment is a portion of a specific path that does not have a well-defined course.

EXAMPLE 1 Figure 13 shows a transformer that is moveable on rails. The cable that feeds the transformer is mounted on the ceiling. The geometry of the section between the last isolator and the transformer changes depending on the position of the transformer. In this case, there will be two Node (see 4.2.208) objects in the ends_at attribute of the Free_segment entity.

EXAMPLE 2 If in Figure 13 the transformer were not yet installed, the last well defined node of the cable is Node (see 4.2.208) 2. In this case, there will be only one Node (see 4.2.208) object in the ends_at attribute of the Free_segment entity. Such cases occur throughout the installation of a system if some design sections are finished earlier than others.

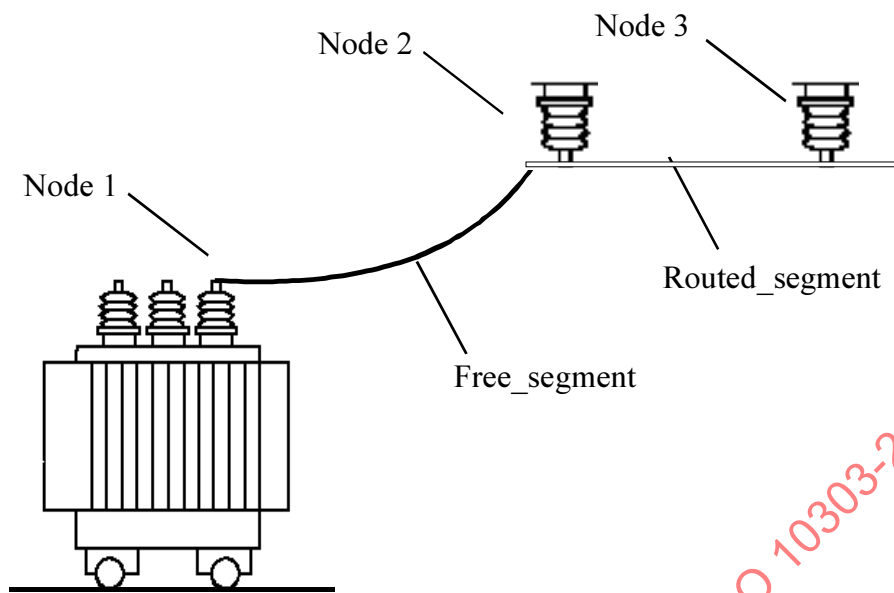

Figure 13 - Power transformer fed through an overhead cable

The data associated with a Free_segment are the following:

- description;
- ends_at;
- id.

4.2.145.1 description

The description specifies an alphanumeric string containing human-interpretable text that gives further details about the Free_segment.

The description need not be specified for a particular Free_segment.

4.2.145.2 ends_at

The ends_at specifies the Node (see 4.2.208) objects that delimits the Free_segment.

See 4.3.1324 for the application assertion.

4.2.145.3 id

The id specifies the identifier of the Free_segment.

4.2.146 Function_definition

A Function_definition is the characterization of a Function_version (see 4.2.150) in a particular application context.

The data associated with a Function_definition are the following:

- additional_context;
- id;
- initial_context;
- name;
- version.

4.2.146.1 additional_context

The additional_context specifies the set of Application_context (see 4.2.22) objects in which this view of the Function_version (see 4.2.150) is also relevant. The additional_context shall not contain the Application_context (see 4.2.22) that is referenced as the 'initial_context'.

See 4.3.1325 for the application assertion.

4.2.146.2 id

The id specifies the identifier of the Function_definition.

4.2.146.3 initial_context

The initial_context specifies the Application_context (see 4.2.22) in which this view of the Function_version (see 4.2.150) has been designed primarily.

See 4.3.1326 for the application assertion.

4.2.146.4 name

The name specifies a speaking designation of the Function_definition.

The name need not be specified for a particular Function_definition.

4.2.146.5 version

The version specifies the Function_version (see 4.2.150) object to which the Function_definition relates.

See 4.3.1327 for the application assertion.

4.2.147 Function_definition_relationship

A Function_definition_relationship is the relation between two Function_definition (see 4.2.145) objects.

ISO 10303-212:2001(E)

The data associated with an `Function_definition_relationship` are the following:

- `description`;
- `related`;
- `relating`;
- `relation_type`.

4.2.147.1 description

The `description` specifies an alphanumeric string containing human-interpretable text that gives further details about the `Function_definition_relationship`.

The `description` need not be specified for a particular `Function_definition_relationship`.

4.2.147.2 related

The `related` specifies the second of the two `Function_definition` (see 4.2.145) objects related by the `Function_definition_relationship`.

See 4.3.1328 for the application assertion.

4.2.147.3 relating

The `relating` specifies the first of the two `Function_definition` (see 4.2.145) objects related by the `Function_definition_relationship`.

See 4.3.1329 for the application assertion.

4.2.147.4 relation_type

The `relation_type` specifies the meaning of the relationship. The value is either user defined or predefined.

The predefined value of `relation_type` is one of the following:

- `alternate`;
- `derivation`;
- `substitution`.

NOTE 1 See 4.2.147.4.1 - 4.2.147.4.3 for the definition of each predefined value for `relation_type`.

4.2.147.4.1 alternate

`alternate`: The `Function_definition_relationship` defines a relationship where the related `Function_definition` (see 4.2.145) is a possible substitute to the relating `Function_definition` (see 4.2.145).

NOTE 2 This concept refers to the possibility to replace the related Function_definition (see 4.2.145). The actual replacement is addressed by 'substitution'.

4.2.147.4.2 derivation

derivation: The Function_definition_relationship defines a deriving relationship where the related Function_definition (see 4.2.145) is based on the relating Function_definition (see 4.2.145).

4.2.147.4.3 substitution

substitution: The Function_definition_relationship defines a relationship where the related Function_definition (see 4.2.145) replaces the relating Function_definition (see 4.2.145).

4.2.148 Function_interface

A Function_interface specifies Interface_port (see 4.2.171) objects that characterize the use or the intended purpose of a functional module.

NOTE The Function_interface can provide a possible selection criterion if a given functional module needs to be substituted by a different one. Possible selection criteria may be assigned as Data_element (see 4.2.70) objects to Function_interface.

The data associated with a Function_interface are the following:

- description;
- external_access;
- id;
- interface_of.

4.2.148.1 description

The description specifies an alphanumerical string containing human-interpretable text that gives further details about the Function_interface.

The description need not be specified for a particular Function_interface.

4.2.148.2 external_access

The external_access specifies the interface by assigning Interface_port (see 4.2.171) objects to the Function_interface.

See 4.3.1331 for the application assertion.

4.2.148.3 id

The id specifies the identifier of the Function_interface.

4.2.148.4 interface_of

ISO 10303-212:2001(E)

The interface_of specifies the associated Function_definition (see 4.2.145).

See 4.3.1330 for the application assertion.

4.2.149 Function_unit

A Function_unit is a type of Product_constituent (see 4.2.266) that is an occurrence of a Function_definition (see 4.2.145) object. A Function_unit may be instantiated more than once, because each instance is an individual occurrence of the functional item that is characterized by the Function_definition (see 4.2.145).

EXAMPLE 1 In a specific technical system, the function 'amplifier' is defined once. This Function_definition (see 4.2.145) carries all the information defining the amplifier (e.g., its ports) that is independent from its usage. Additionally, two Function_unit objects for this amplifier exist because two equal amplifiers are used within this particular circuitry. Each of these instances may be connected individually.

Each Function_unit is either a Single_function_unit (see 4.2.315) or a Specified_function_unit (see 4.2.329).

The data associated with a Function_unit are the following:

- description;
- extended_designation;
- id;
- instantiated_function.

4.2.149.1 description

The description specifies an alphanumerical string containing human-interpretable text that gives further details about the Function_unit.

The description need not be specified for a particular Function_unit.

4.2.149.2 extended_designation

The extended_designation specifies a structured label for the Function_unit.

NOTE The label assigned through extended_designation shall be identical to the label assigned by the 'id' attribute.

EXAMPLE 2 IEC 61346-1 specifies designations and structuring principles for Function_unit objects.

The extended_designation need not be specified for a particular Function_unit.

See 4.3.1333 for the application assertion.

4.2.149.3 id

The id specifies the identifier of the Function_unit.

4.2.149.4 instanciated_function

An instanciated_function specifies the Function_definition (see 4.2.145) that serves as template for the Function_unit or Product_identification (see 4.2.268).

Each instanciated_function may be one of the following: Function_definition (see 4.2.145) or Product_identification (see 4.2.268).

See 4.3.1332 and 4.3.1334 for the application assertions.

4.2.150 Function_unit_relationship

A Function_unit_relationship is the relation between two Function_unit (see 4.2.148) objects.

NOTE The associated Function_unit (see 4.2.148) objects do not necessarily belong to the same Function_definition (see 4.2.145) object.

The data associated with an Function_unit_relationship are the following:

- description;
- related;
- relating;
- relation_type.

4.2.150.1 description

The description specifies an alphanumeric string containing human-interpretable text that gives further details about the Function_unit_relationship.

The description need not be specified for a particular Function_unit_relationship.

4.2.150.2 related

The related specifies the second of the two Function_unit (see 4.2.148) objects related by the Function_unit_relationship.

See 4.3.1335 for the application assertion.

4.2.150.3 relating

The relating specifies the first of the two Function_unit (see 4.2.148) objects related by the Function_unit_relationship.

See 4.3.1336 for the application assertion.

4.2.150.4 relation_type

ISO 10303-212:2001(E)

The `relation_type` specifies the meaning of the relationship. The value is either user defined or predefined.

The predefined value of `relation_type` is one of the following:

- derivation;
- implementation;
- redundancy;
- specialization;
- substitution.

NOTE See 4.2.150.4.1 - 4.2.150.4.5 for the definition of each predefined value for `relation_type`.

4.2.150.4.1 derivation

derivation: The `Function_unit_relationship` defines a deriving relationship where the related `Function_unit` (see 4.2.148) is based on the relating `Function_unit` (see 4.2.148).

4.2.150.4.2 implementation

implementation: The `Function_unit_relationship` defines a relationship where the related `Function_unit` (see 4.2.148) is the realization on the relating `Function_unit` (see 4.2.148).

EXAMPLE 1 A function 'Error handling', specified by a contractor, is implemented by functions 'Monitoring', 'Storage', and 'User interface', taken from a library of standard functions. Each of the standard functions are allocated to Device (see 4.2.88) objects representing the software and hardware components that actually process the error messages.

4.2.150.4.3 redundancy

redundancy: The `Function_unit_relationship` defines a relationship where the related `Function_unit` (see 4.2.148) is replicated by the relating `Function_unit` (see 4.2.148).

EXAMPLE 2 The flight controller in an aircraft is built up with a threefold redundancy. The modules compare their output values and can detect possible problems. The modules use different algorithms, thus avoiding that all modules show the same faulty behaviour.

4.2.150.4.4 specialization

specialization: The `Function_unit_relationship` defines a relationship where the related `Function_unit` (see 4.2.148) fulfils the requirements of the relating `Function_unit` (see 4.2.148) in a more specific way than defined for the relating `Function_unit` (see 4.2.148).

4.2.150.4.5 substitution

substitution: The `Function_unit_relationship` defines a relationship where the related `Function_unit` (see 4.2.148) replaces the relating `Function_unit` (see 4.2.148).

EXAMPLE 3 A Function_unit (see 4.2.148) is substituted by a Function_unit (see 4.2.148) of different behaviour.

4.2.151 Function_version

A Function_version is a version of an Functionality (see 4.2.155) and serves as the collector of the data characterizing a Functionality (see 4.2.155) object in various application contexts.

NOTE 1 An Function_version may be produced, consumed, used to produce other Function_version objects, or offered to the market.

NOTE 2 The collection of defining information may be incomplete, i.e., not all of the Function_definition (see 4.2.145) objects needed to define an Function_version are associated with the Function_version.

NOTE 3 The set of Function_version objects of an Functionality (see 4.2.155) represents the history of the Functionality (see 4.2.155) within a particular life cycle stage or over its complete life cycle.

NOTE 4 An Function_version may not be referenced by a Function_definition (see 4.2.145).

The data associated with a Function_version are the following:

- base_function;
- description;
- version_id.

4.2.151.1 base_function

The base_function specifies the Functionality (see 4.2.155) with which the Function_version is associated.

See 4.3.1337 for the application assertion.

4.2.151.2 description

The description specifies an alphanumerical string containing human-interpretable text that gives further details about the Function_version.

The description need not be specified for a particular Function_version.

4.2.151.3 version_id

The version_id specifies versioning information for the Function_version.

4.2.152 Function_version_relationship

A Function_version_relationship is the relation between two Function_version (see 4.2.150) objects.

ISO 10303-212:2001(E)

The data associated with an `Function_version_relationship` are the following:

- `description`;
- `related`;
- `relating`;
- `relation_type`.

4.2.152.1 `description`

The `description` specifies an alphanumerical string containing human-interpretable text that gives further details about the `Function_version_relationship`.

The `description` need not be specified for a particular `Function_version_relationship`.

4.2.152.2 `related`

The `related` specifies the second of the two `Function_version` (see 4.2.150) objects related by the `Function_version_relationship`.

See 4.3.1338 for the application assertion.

4.2.152.3 `relating`

The `relating` specifies the first of the two `Function_version` (see 4.2.150) objects related by the `Function_version_relationship`.

See 4.3.1339 for the application assertion.

4.2.152.4 `relation_type`

The `relation_type` specifies the meaning of the relationship. The value is either user defined or predefined.

The predefined value of `relation_type` is one of the following:

- derivation;
- hierarchy;
- sequence;
- supplied function.

NOTE See 4.2.152.4.1 - 4.2.152.4.4 for the definition of each predefined value for `relation_type`.

4.2.152.4.1 derivation

derivation: The `Function_version_relationship` defines a deriving relationship where the related `Function_version` (see 4.2.150) is based on the relating `Function_version` (see 4.2.150) which is an earlier version of the same or of a different `Functionality` (see 4.2.155).

4.2.152.4.1 hierarchy

hierarchy: The `Function_version_relationship` defines a hierarchical relationship where the related `Function_version` (see 4.2.150) is a subversion of the relating `Function_version` (see 4.2.150).

EXAMPLE Revision 1.1 and 1.2 of a document.

4.2.152.4.2 sequence

sequence: The `Function_version_relationship` defines a succession of versions where the relating `Function_version` (see 4.2.150) is the preceding version and the related `Function_version` (see 4.2.150) is the following version. For a `Function_version` (see 4.2.150) there shall be, at the most, one `Function_version_relationship` of this relation type as relating and, at most, one `Function_version_relationship` of this relation type as related.

4.2.152.4.3 supplied function

supplied function: The `Function_version_relationship` defines a relationship between two `Function_version` (see 4.2.150) objects representing the same module in different organizational contexts.

NOTE The different organizational contexts can be represented by different organizational data.

4.2.153 Functional_connectivity_definition

A `Functional_connectivity_definition` is a specification of the ability to enable the flow of information within a functional module.

Each `Functional_connectivity_definition` is either an `Interface_port_connectivity` (see 4.2.172) or a `Network` (see 4.2.206).

ISO 10303-212:2001(E)

The data associated with a `Functional_connectivity_definition` are the following:

- `connectivity_of`;
- `description`;
- `id`;
- `version_id`.

4.2.153.1 `connectivity_of`

The `connectivity_of` specifies the `Function_definition` (see 4.2.145) object, the internal connectivity of which is specified by `Functional_connectivity_definition`.

See 4.3.1340 for the application assertion.

4.2.153.2 `description`

The `description` specifies an alphanumeric string containing human-interpretable text that gives further details about the `Functional_connectivity_definition`.

The `description` need not be specified for a particular `Functional_connectivity_definition`.

4.2.153.3 `id`

The `id` specifies the identifier of the `Functional_connectivity_definition`.

4.2.153.4 `version_id`

The `version_id` specifies versioning information for the `Functional_connectivity_definition`.

The `version_id` need not be specified for a particular `Functional_connectivity_definition`.

4.2.154 `Functional_connectivity_definition_relationship`

A `Functional_connectivity_definition_relationship` is the relation between two `Functional_connectivity_definition` (see 4.2.152) objects.

The data associated with an `Functional_connectivity_definition_relationship` are the following:

- `description`;
- `related`;
- `relating`;
- `relation_type`.

4.2.154.1 description

The `description` specifies an alphanumeric string containing human-interpretable text that gives further details about the `Functional_connectivity_definition_relationship`.

The `description` need not be specified for a particular `Functional_connectivity_definition_relationship`.

4.2.154.2 related

The `related` specifies the second of the two `Functional_connectivity_definition` (see 4.2.152) objects related by the `Functional_connectivity_definition_relationship`.

See 4.3.1341 for the application assertion.

4.2.154.3 relating

The `relating` specifies the first of the two `Functional_connectivity_definition` (see 4.2.152) objects related by the `Functional_connectivity_definition_relationship`.

See 4.3.1342 for the application assertion.

4.2.154.4 relation_type

The `relation_type` specifies the meaning of the relationship. The value is either user defined or predefined.

ISO 10303-212:2001(E)

The predefined value of `relation_type` is one of the following:

- alternate;
- decomposition;
- derivation;
- substitution;
- redundancy;
- version hierarchy;
- version sequence.

NOTE 1 See 4.2.154.4.1 - 4.2.154.4.7 for the definition of each predefined value for `relation_type`.

4.2.154.4.1 alternate

alternate: The `Functional_connectivity_definition_relationship` defines a relationship where the related `Functional_connectivity_definition` (see 4.2.152) is a possible substitute to the relating `Functional_connectivity_definition` (see 4.2.152).

NOTE 2 This concept refers to the possibility to replace the related `Functional_connectivity_definition` (see 4.2.152). The actual replacement is addressed by 'substitution'.

4.2.154.4.2 decomposition

decomposition: The `Functional_connectivity_definition_relationship` defines a relationship where the related `Functional_connectivity_definition` (see 4.2.152) is one of the components into which the relating `Functional_connectivity_definition` (see 4.2.152) is divided.

4.2.154.4.3 derivation

derivation: The `Functional_connectivity_definition_relationship` defines a deriving relationship where the related `Functional_connectivity_definition` (see 4.2.152) is based on the relating `Functional_connectivity_definition` (see 4.2.152).

4.2.154.4.4 substitution

substitution: The `Functional_connectivity_definition_relationship` defines a relationship where the related `Functional_connectivity_definition` (see 4.2.152) replaces the relating `Functional_connectivity_definition` (see 4.2.152).

4.2.154.4.5 redundancy

redundancy: The `Functional_connectivity_definition_relationship` defines a relationship where the related `Functional_connectivity_definition` (see 4.2.152) is replicated by the relating `Functional_connectivity_definition` (see 4.2.152).

EXAMPLE In an aircraft the connectivity from the flight controller to the steering elements is replicated for safety reasons.

4.2.154.4.6 version hierarchy

version hierarchy: The `Functional_connectivity_definition_relationship` defines a hierarchical relationship where the related `Functional_connectivity_definition` (see 4.2.152) is a subversion of the relating `Functional_connectivity_definition` (see 4.2.152).

EXAMPLE Revisions 1.1 and 1.2 of a `Functional_connectivity_definition` (see 4.2.152).

4.2.154.4.7 version sequence

version sequence: The `Functional_connectivity_definition_relationship` defines a succession of versions where the relating `Functional_connectivity_definition` (see 4.2.152) is the preceding version, and the related `Functional_connectivity_definition` (see 4.2.152) is the following version.

4.2.155 Functional_unit_allocation

A `Functional_unit_allocation` is the relation that specifies the equipment selected to implement the specified `Function_unit` (see 4.2.148).

The data associated with a `Functional_unit_allocation` are the following:

- `allocated_functional_unit`;
- description;
- `function_implementation`.

4.2.155.1 allocated_functional_unit

The `allocated_functional_unit` specifies the `Function_unit` (see 4.2.148) object that is implemented.

See 4.3.1344 for the application assertion.

4.2.155.2 description

The description specifies an alphanumerical string containing human-interpretable text that gives further details about the `Functional_unit_allocation`.

The description need not be specified for a particular `Functional_unit_allocation`.

4.2.155.3 function_implementation

The `function_implementation` specifies the equipment that implements a `Function_unit` (see 4.2.148).

Each `function_implementation` may be one of the following: `Device` (see 4.2.88), `Physical_instance` (see 4.2.243), or `Product_component` (see 4.2.265).

See 4.3.1343, 4.3.1345, and 4.3.1346 for the application assertions.

4.2.156 Functionality

A Functionality is an action or behaviour by which an electrical product fulfils its purpose.

NOTE A Functionality may be either primitive, i.e., its internal structure is not further described or it may be assembled from other functions. Functionality can be used as a specification or requirement for the implementation or as a functional description of an existing circuit.

The data associated with a Functionality are the following:

- description;
- id;
- name.

4.2.156.1 description

The description specifies an alphanumeric string containing human-interpretable text that gives further details about the Functionality.

The description need not be specified for a particular Functionality.

4.2.156.2 id

The id specifies the identifier of the Functionality.

4.2.156.3 name

The name specifies a speaking designation of the Functionality.

The name need not be specified for a particular Functionality.

4.2.157 General_classification

A General_classification is a classification of an object which characterizes all objects of the same kind; such a classification is independent from the application of the classified object.

EXAMPLE 1 This information can be used as a criterion for selecting a specific type of equipment from a component database.

EXAMPLE 2 IEC 61355 specifies a classification system for documents.

EXAMPLE 3 IEC 3B/245/CDV (IEC 61346-2) specifies a classification system for objects.

EXAMPLE 4 IEC 81714-3 specifies a classification system for connect nodes and networks.

EXAMPLE 5 IEC 60529 specifies a classification system for the degree of protection provided by enclosures.

EXAMPLE 6 IEC 60721 specifies a classification system for environmental conditions.

The data associated with a General_classification are the following:

- classification_source;
- description;
- id;
- used_classification_system;
- version_id.

4.2.157.1 classification_source

The classification_source specifies a reference under which the specification of the General_classification can be found.

The classification_source need not be specified for a particular General_classification.

Each classification_source may be one of the following: Class_reference (see 4.2.43) or External_library_reference (see 4.2.132).

See 4.3.1347 and 4.3.1349 for the application assertions.

4.2.157.2 description

The description specifies an alphanumeric string containing human-interpretable text that gives further details about the General_classification.

The description need not be specified for a particular General_classification.

4.2.157.3 id

The id specifies the identifier of the General_classification.

4.2.157.4 used_classification_system

The used_classification_system specifies the Classification_system (see 4.2.48) that contains the definition of the classification.

See 4.3.1348 for the application assertion.

4.2.157.5 version_id

The version_id specifies versioning information for the General_classification.

The version_id need not be specified for a particular General_classification.

4.2.158 General_classification_hierarchy

A General_classification_hierarchy is the specification of a hierarchical structure for General_classification (see 4.2.156) objects.

ISO 10303-212:2001(E)

The data associated with a `General_classification_hierarchy` are the following:

- `sub_class`;
- `super_class`.

4.2.158.1 `sub_class`

The `sub_class` specifies the lower level `General_classification` (see 4.2.156) in a classification-hierarchy that is included in the super class.

See 4.3.1350 for the application assertion.

4.2.158.2 `super_class`

The `super_class` specifies the higher level `General_classification` (see 4.2.156) in a classification-hierarchy that includes the sub class.

See 4.3.1351 for the application assertion.

4.2.159 `General_location_relationship`

A `General_location_relationship` is a type of `Location_relationship` (see 4.2.194) that is the relation between two `Location` (see 4.2.192) objects.

The data associated with an `General_location_relationship` are the following:

- `description`;
- `relation_type`.

4.2.159.1 `description`

The `description` specifies an alphanumerical string containing human-interpretable text that gives further details about the `General_location_relationship`.

The `description` need not be specified for a particular `General_location_relationship`.

4.2.159.2 `relation_type`

The `relation_type` specifies the meaning of the relationship. The value is either user defined or predefined.

The predefined value of `relation_type` is one of the following:

- alternate;
- substitution;
- version hierarchy;
- version sequence.

NOTE 1 See 4.2.159.2.1 - 4.2.159.2.3 for the definition of each predefined value for `relation_type`.

4.2.159.2.1 alternate

alternate: The `General_location_relationship` defines a relationship where the related Location (see 4.2.192) is a possible substitute to the relating Location (see 4.2.192).

NOTE 2 This relationship may be used to indicate that two different Location (see 4.2.192) objects specify the same place regardless of rounding errors or the assignment to different location trees.

NOTE 3 This concept refers to the possibility to replace the Location (see 4.2.192). The actual replacement is addressed by 'substitution'.

4.2.159.2.2 substitution

substitution: The `General_location_relationship` defines a relationship where the related Location (see 4.2.192) replaces the relating Location (see 4.2.192).

4.2.159.2.3 version hierarchy

version hierarchy: The `General_location_relationship` defines a hierarchical relationship where the related Location (see 4.2.192) is a subversion of the relating Location (see 4.2.192).

EXAMPLE Revisions 1.1 and 1.2 of a Location (see 4.2.192).

4.2.159.2.4 version sequence

version sequence: The `General_location_relationship` defines a succession of versions where the relating Location (see 4.2.192) is the preceding version, and the related Location (see 4.2.192) is the following version.

4.4.2.160 Generic_note

A `Generic_note` is human-interpretable information that gives further details on a specific thing of interest. By using notes, explanatory information may be added to the product data.

Each `Generic_note` is either a `Note` (see 4.2.210) or a `Set_of_notes` (see 4.2.305).

ISO 10303-212:2001(E)

The data associated with a `Generic_note` are the following:

- `description`;
- `id`;
- `version_id`.

4.2.160.1 `description`

The `description` specifies an alphanumeric string containing human-interpretable text that gives further details about the `Generic_note`.

The `description` need not be specified for a particular `Generic_note`.

4.2.160.2 `id`

The `id` specifies the identifier of the `Generic_note`.

4.2.160.3 `version_id`

The `version_id` specifies versioning information for the `Generic_note`.

The `version_id` need not be specified for a particular `Generic_note`.

4.2.161 `Geometrical_tolerance`

A `Geometrical_tolerance` is a type of `Draughting_callout` (see 4.2.117) that is a combination of geometric characteristic symbols, tolerance values, and datum designations, where applicable, to express the permissible variation from the theoretically exact size, profile, orientation, or location of a feature or datum target.

4.2.162 `Geometrical_tolerance_symbol`

A `Geometrical_tolerance_symbol` is a type of `Predefined_symbol` (see 4.2.255) that is used to establish a tolerance zone within which the specified conditions of the tolerance apply.

The predefined `Geometrical_tolerance_symbol` that shall be supported by all implementations of this part of ISO 10303 are dependent on the height (h) of the text that the symbol accompanies. The height of the characters for the predefined symbols specified here shall be $h = 2.5$ mm. The graphics shown in Figure 14 are oriented as they appear in a horizontally placed tolerance frame.

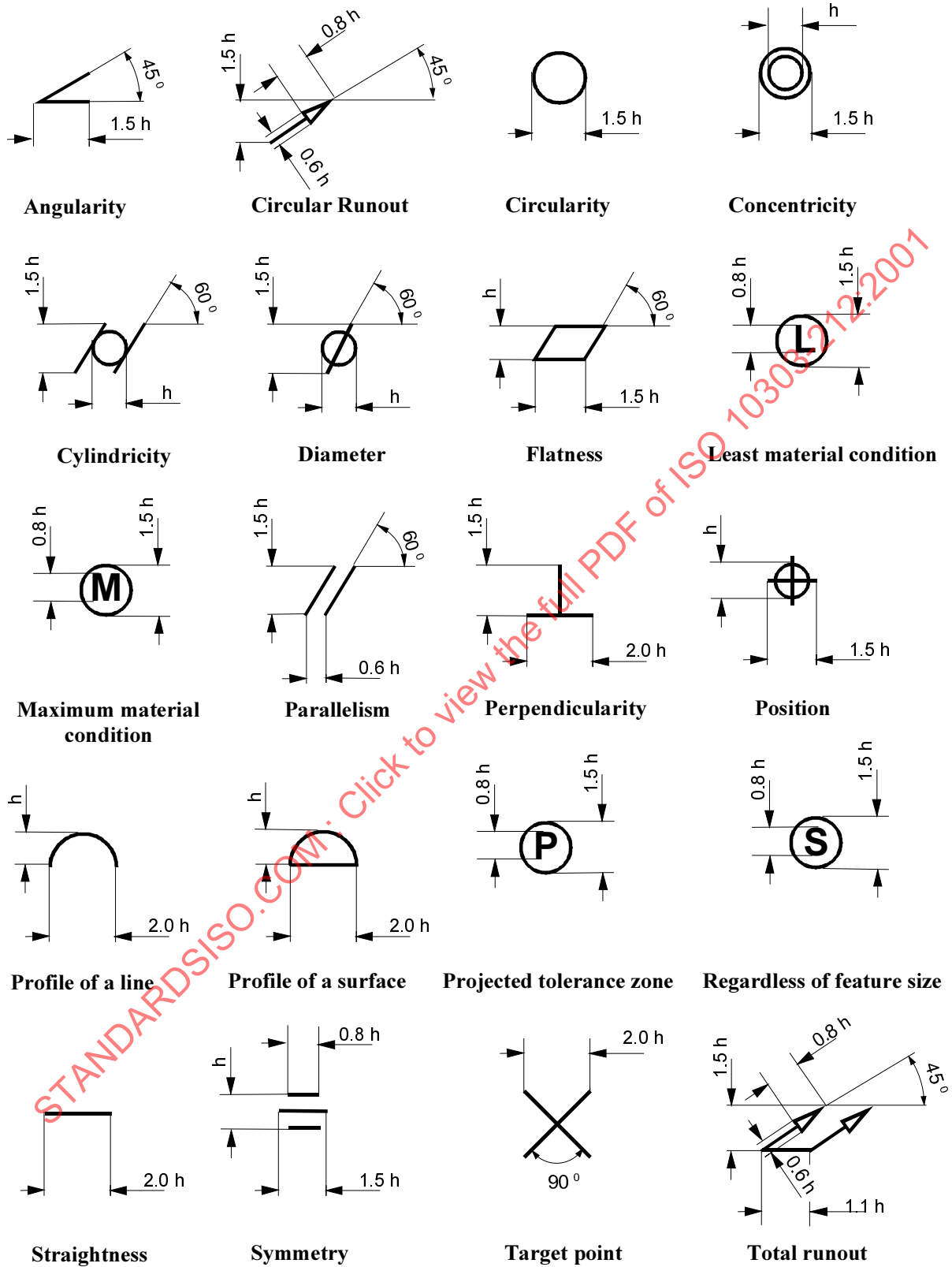

Figure 14 - Predefined geometrical tolerance symbols

ISO 10303-212:2001(E)

The data associated with a Geometrical_tolerance_symbol are the following:

- symbol_type.

4.2.162.1 symbol_type

The name specifies an alphanumerical string identifying the Geometrical_tolerance_symbol in accordance to the definitions given above.

The value of symbol_type is one of the following:

- angularity;
- circular runout;
- circularity;
- concentricity;
- cylindricity;
- diameter;
- flatness;
- least material condition;
- maximum material condition;
- parallelism;
- perpendicularity;
- position;
- profile of a line;
- profile of a surface;
- projected tolerance zone;
- regardless of feature size;
- straightness;
- symmetry;
- target point;
- total runout.

NOTE See 4.2.162.1.1 - 4.2.162.1.20 for the definition of each permissible value for symbol_type.

4.2.162.1.1 angularity

angularity: An angularity symbol is used to define the condition of a surface or line that is at the specified angle, other than 90 degrees, from a datum plane or axis. An angularity symbol is depicted as two line segments that form an open triangle. The origin of the symbol is the intersection point of the two lines. The size and graphical representation of the symbol are shown in Figure 14.

4.2.162.1.2 circular runout

circular runout: A circular-runout symbol is used to define the maximum permissible surface variation at any fixed point during one complete rotation of the part about the datum axis. A circular-runout symbol is depicted as a leader and terminated by an arrow. The origin of the symbol is the start of the leader line. The size and graphical representation of the symbol are shown in Figure 14.

4.2.162.1.3 circularity

circularity: A circularity symbol is used to define the condition of a surface of revolution where all points of the surface intersected by any plane, perpendicular to a common axis or passing through a common centre, are equidistant from the axis. A circularity symbol is depicted as a circle. The origin of the symbol is the centre of the circle. The size and graphical representation of the symbol are shown in Figure 14.

4.2.162.1.4 concentricity

concentricity: A concentricity symbol is used to define the condition wherein the axis of all cross sectional elements of a cylinder, cone, or sphere are common to a datum axis. A concentricity symbol is depicted as two concentric circles. The origin of the symbol is the common centre of the circles. The origin of the symbol is the centre of the circle. The size and graphical representation of the symbol are shown in Figure 14.

4.2.162.1.5 cylindricity

cylindricity: A cylindricity symbol is used to define two concentric cylinders between which all elements of the specified surface must lie. A cylindricity symbol is depicted as a circle, combined with two tangential and parallel lines. The origin of the symbol is the centre of the circle. The size and graphical representation of the symbol are shown in Figure 14.

4.2.162.1.6 diameter

diameter: A diameter symbol is used to indicate that the associated notation applies diametrically. A diameter symbol is depicted as a circle, crossed by a line segment. The origin of the symbol is the centre of the circle. The size and graphical representation of the symbol are shown in Figure 14.

4.2.162.1.7 flatness

flatness: A flatness symbol is used to define the allowable perpendicular deviation of surface elements from the plane in which they reside. A flatness symbol is depicted as a parallelogram. The origin of the symbol is the lower, left corner of the parallelogram. The size and graphical representation of the symbol are shown in Figure 14.

ISO 10303-212:2001(E)

4.2.162.1.8 least material condition

least material condition: A least material condition symbol is used to define that the given tolerance applies to the part feature at the tolerance limit where the material content is at its minimum. The symbol is depicted as a circle with the character 'L' positioned in its centre. The origin of the symbol is the centre of the circle. The size and graphical representation of the symbol are shown in Figure 14.

4.2.162.1.9 maximum material condition

maximum material condition: A maximum material condition symbol is used to define that the given tolerance applies to the part feature at the tolerance limit where the material content is at its maximum. A maximum material condition symbol is depicted as a circle with the character 'M' positioned in its centre. The origin of the symbol is the centre of the circle. The size and graphical representation of the symbol are shown in Figure 14.

4.2.162.1.10 parallelism

parallelism: A parallelism symbol is used to define the condition of a surface, axis, or line that is equidistant at all points from a datum plane or axis. A parallelism symbol is depicted as two parallel line segments. The origin of the symbol is the starting point of the first line segment on the left. The size and graphical representation of the symbol are shown in Figure 14.

4.2.162.1.11 perpendicularity

perpendicularity: A perpendicularity symbol is used to define the condition of a surface, axis, or line that is at right angles to a datum plane or axis. A perpendicularity symbol is depicted as two lines, one placed perpendicular to the other. The origin of the symbol is the point of intersection of the two line segments. The size and graphical representation of the symbol are shown in Figure 14.

4.2.162.1.12 position

position: A position symbol is used to define a condition wherein a part or feature has the same contour and is on opposite sides of a central plane, or a condition in which a feature is symmetrically disposed about the central plane of a datum feature. A position symbol is depicted as a circle, crossed by two perpendicular lines, intersected in the centre of the circle. The origin of the symbol is the centre of the circle. The size and graphical representation of the symbol are shown in Figure 14.

4.2.162.1.13 profile of a line

profile of a line: A profile of a line symbol is used to define a tolerance zone, always perpendicular to the profile at points of the profile, within which the specified line must lie. A profile of a line symbol is depicted as an arc. The origin of the symbol is the start point on the left of the arc line. The size and graphical representation of the symbol are shown in Figure 14.

4.2.162.1.14 profile of a surface

profile of a surface: A profile of a surface symbol is used to define a tolerance zone, always perpendicular to the surface, within which the specified surface must lie. A profile of a surface symbol is depicted as a closed arc. The origin of the symbol is the midpoint of the line between the start point and the end point of the arc. The size and graphical representation of the symbol are shown in Figure 14.

4.2.162.1.15 projected tolerance zone

projected tolerance zone: A projected tolerance zone symbol is used to define the height or depth to which a tolerance of a location applies. A projected tolerance zone symbol is depicted as a circle with the character 'P' positioned at its centre. The origin of the symbol is the centre of the circle. The size and graphical representation of the symbol are shown in Figure 14.

4.2.162.1.16 regardless of feature size

regardless of feature size: A regardless of feature size symbol is used to specify that the given tolerance applies to the feature regardless of its size variation. A regardless of feature size symbol is depicted as a circle with the character 'S' positioned in its centre. The origin of the symbol is the centre of the circle. The size and graphical representation of the symbol are shown in Figure 14.

4.2.162.1.17 straightness

straightness: A straightness symbol is used to define a tolerance zone within which the considered element must lie and where the element is repressed by a straight line. A straightness symbol is depicted as a straight line segment, horizontal to the tolerance frame. The origin of the symbol is the left end point of the segment. The size and graphical representation of the symbol are shown in Figure 14.

4.2.162.1.18 symmetry

symmetry: A symmetry symbol is used to define the condition wherein all elements of the feature being toleranced must lie equidistant from the specified datum within the zone defined by the tolerance. A symmetry symbol is depicted as three parallel, horizontal line segments. The origin of the symbol is the midpoint of the middle line segment. The size and graphical representation of the symbol are shown in Figure 14.

4.2.162.1.19 target point

target point: A target point symbol is used to identify a specific point that is to be used as the datum reference point. A target point is depicted as two perpendicular line segments. The origin of the symbol is the intersection point of the two line segments. The size and graphical representation of the symbol are shown in Figure 14.

4.2.162.1.20 total runout

total runout: A total runout symbol is used to define the maximum permissible surface variation of all surface elements during one complete rotation of the part about the datum axis. A total runout symbol is depicted as two parallel leader lines, each terminated by an arrow. The origin of the symbol is the starting point of the leader on the left. The size and graphical representation of the symbol are shown in Figure 14.

4.2.163 Gis_position

A Gis_position is the positioning and orientation information necessary for transforming coordinate values between a local coordinate space and the global coordinate space of the earth. Transformation procedures depend on the GIS coordinate system.

ISO 10303-212:2001(E)

EXAMPLE 1 A detailed discussion of global positioning systems is provided in: HOFMANN - WELLENHOF B., LICHTENEGGER H., COLLINS J., *Global Positioning System - Theory and Practice*; Fourth Edition, Springer Verlag Wien, New York, 1997.

The data associated with a `Gis_position` are the following:

- height;
- scale;
- system;
- `x_axis_delta_x`;
- `x_axis_delta_y`;
- `x_coordinate`;
- `y_coordinate`;
- zone.

4.2.163.1 height

The height specifies the distance of the origin of the local coordinate system above the zero elevation datum.

NOTE The zero elevation datum, also referred as sea level, is specified by the geodetic authorities for the region in question.

4.2.163.2 scale

The scale specifies a transformation factor applied to the conversion of point coordinates between a local coordinate system and a GIS coordinate system. The precise application of the transformation will depend on the GIS system.

4.2.163.3 system

The system specifies the identifier of the GIS system being used.

EXAMPLE 2 Gauss-Krueger, Universal Transverse Mercator (UTM), and State Plane are examples of GIS systems used for global positioning.

4.2.163.4 `x_axis_delta_x`

The `x_axis_delta_x` specifies the abscissa value of the end point of a vector indicating the positive x axis of GIS coordinate space in the local coordinate system.

4.2.163.5 `x_axis_delta_y`

The `x_axis_delta_y` specifies the ordinate value of the end point of a vector indicating the orientation of the positive x axis of the GIS coordinate space in the local coordinate system.

EXAMPLE 3 The GIS coordinate system XY00 has an origin at the intersection of the equator and the Greenwich meridian; the *x*_axis of the coordinate system runs East (positive) and West (negative); the *y*_axis runs North (positive) and South (negative); the positive *z*_axis is up. An *x*_axis_delta_x of 1.0 and *x*_axis_delta_y of 1.0 indicates that the *x* axis of the GIS coordinate space makes a +45° angle with respect to the *x* axis of the local coordinate system. If the local coordinate space was superimposed on the GIS coordinate space, the positive *x*_axis of the local coordinate system would point in a Southeast direction (-45°).

4.2.163.6 *x*_coordinate

The *x*_coordinate specifies the distance from the *y* axis of the coordinate space defined by the GIS system and zone.

4.2.163.7 *y*_coordinate

The *y*_coordinate specifies the distance from the *x* axis of the coordinate space defined by the GIS system and zone.

4.2.163.8 zone

The zone specifies a subdivision of the earth's surface based on the GIS system.

EXAMPLE 4 The Gauss-Krueger GIS system subdivides the earth into 120 zones, each of which is 3° in longitudinal width. Each zone is identified as 3°, 6°, 9°, etc., from the Greenwich meridian.

4.2.164 Group

A Group is a collection of graphical elements and other previously defined groups generated into related sets.

The data associated with a Group are the following:

- description;
- id;
- members.

4.2.164.1 description

The description specifies an alphanumeric string containing human-interpretable text that gives further details about the Group.

The description need not be specified for a particular Group.

4.2.164.2 id

The id specifies the identifier of the Group.

4.2.164.3 members

ISO 10303-212:2001(E)

The members specifies the annotation elements or subgroups that are contained within the Group.

See 4.3.1352 for the application assertion.

4.2.165 Group_annotation_element

A Group_annotation_element is a type of Group_element (see 4.2.165) that is the annotation contained in a Group (see 4.2.163).

The data associated with a Group_annotation_element are the following:

— basis_annotation.

4.2.165.1 basis_annotation

The basis_annotation specifies the Draughting_annotation (see 4.2.116) that is contained in the Group (see 4.2.163).

See 4.3.1353 for the application assertion.

4.2.166 Group_element

A Group_element is an annotation or another Group (see 4.2.163) object that is a member of a Group (see 4.2.163).

Each Group_element is either a Group_annotation_element (see 4.2.164) or a Sub_group (see 4.2.333).

4.2.167 Hardcopy

A Hardcopy is a type of Document_file (see 4.2.106) that is a document or a portion thereof that is provided in nondigital form.

4.2.168 Hatching_pattern

A Hatching_pattern is a single, uniformly spaced geometric pattern of lines. The basis of the hatching pattern is an infinite straight line that is repeated across the fill area and clipped to its boundaries.

The data associated with a Hatching_pattern are the following:

— angle;

— displacement;

— hatch_line_appearance.

4.2.168.1 angle

The angle specifies the angular rotation of the curves of the hatching pattern, measured counter-clockwise, from the x-axis of the coordinate system into which the hatching pattern is placed.

4.2.168.2 displacement

The displacement specifies a vector that positions the adjacent lines of the hatch pattern from the current line.

4.2.168.3 hatch_line_appearance

The hatch_line_appearance specifies the outlook of the curves used to create a Hatching_pattern.

See 4.3.1354 for the application assertion.

4.2.169 Hierarchical_location_relationship

A Hierarchical_location_relationship is a type of Location_relationship (see 4.2.194) that specifies the relationship where the related Location (see 4.2.192) is a sub-location into which the relating Location (see 4.2.192) is divided.

NOTE It is understood that a sublocation is inside the higher-level location.

The data associated with a Hierarchical_location_relationship are the following:

- description;
- transformation.

4.2.169.1 description

The description specifies an alphanumeric string containing human-interpretable text that gives further details about the Hierarchical_location_relationship.

The description need not be specified for a particular Hierarchical_location_relationship.

4.2.169.2 transformation

The transformation specifies the geometrical transformation that is used to calculate the exact spatial position of the sublocation within the Location (see 4.2.192).

The transformation need not be specified for a particular Hierarchical_location_relationship.

4.2.170 Instance_placement

An Instance_placement is the information describing how to place a physical or functional item that is defined in its own coordinate space in the coordinate space of a superordinate Product_component (see 4.2.265).

ISO 10303-212:2001(E)

The data associated with an Instance_placement are the following:

- placed_instance;
- referenced_product_component;
- transformation.

4.2.170.1 placed_instance

The placed_instance specifies the item that is placed.

Each placed_instance may be one of the following: Single_device (see 4.2.314) or Single_function_unit (see 4.2.315).

See 4.3.1356 and 4.3.1357 for the application assertions.

4.2.170.2 referenced_product_component

The referenced_product_component specifies the superordinate Product_component (see 4.2.265) that is defined in the reference coordinate space.

See 4.3.1355 for the application assertion.

4.2.170.3 transformation

The transformation specifies the geometrical transformation between the local coordinate system of the item that is placed into the reference coordinate system of the associated Product_component (see 4.2.265).

4.2.171 Interface

An Interface specifies Interface_terminal (see 4.2.174) objects that characterize the use or the intended purpose of a piece of equipment.

NOTE The Interface may provide a possible selection criterion if a given piece of equipment needs to be substituted by a different one. Possible selection criteria may be assigned as Data_ - element (see 4.2.70) objects to the Interface.

The data associated with an Interface are the following:

- description;
- external_access;
- id;
- interface_of.

4.2.171.1 description

The description specifies an alphanumeric string containing human-interpretable text that gives further details about the Interface.

The description need not be specified for a particular Interface.

4.2.171.2 external_access

The external_access specifies the interface by assigning Interface_terminal (see 4.2.174) objects to the Interface.

See 4.3.1359 for the application assertion.

4.2.171.3 id

The id specifies the identifier of the Interface.

4.2.171.4 interface_of

The interface_of specifies the Design_discipline_item_definition (see 4.2.86) to which the Interface belongs.

See 4.3.1358 for the application assertion.

4.2.172 Interface_port

An Interface_port defines a single access point for the functionality of a piece of equipment.

The data associated with an Interface_port are the following:

- description;
- id;
- interface_port_of.

4.2.172.1 description

The description specifies an alphanumeric string containing human-interpretable text that gives further details about the Interface_port.

The description need not be specified for a particular Interface_port.

4.2.172.2 id

The id specifies the identifier of the Interface_port.

4.2.172.3 interface_port_of

The interface_port_of specifies the Function_definition (see 4.2.145) to which the Interface_port is assigned.

See 4.3.1360 for the application assertion.

4.2.173 Interface_port_connectivity

An Interface_port_connectivity is a type of Functional_connectivity_definition (see 4.2.152) that is a link between Interface_port (see 4.2.171) objects that are connected internally in the functional module.

NOTE The Interface_port_connectivity allows to specify internal networks between the access nodes of Function_definition (see 4.2.145) objects belonging to the same Function_version (see 4.2.150) without the need to describe the internal structure of the module.

EXAMPLE The internal connectivity of a jumper module can be expressed by using Interface_port_connectivity objects.

The data associated with an Interface_port_connectivity are the following:

— connected_interface_port.

4.2.173.1 connected_interface_port

The connected_interface_port specifies the linked Interface_port (see 4.2.171) objects.

See 4.3.1361 for the application assertion.

4.2.174 Interface_port_relationship

A Interface_port_relationship is the relation between two Interface_port (see 4.2.171) objects.

The data associated with an `Interface_port_relationship` are the following:

- `description`;
- `related`;
- `relating`;
- `relation_type`.

4.2.174.1 `description`

The `description` specifies an alphanumeric string containing human-interpretable text that gives further details about the `Interface_port_relationship`.

The `description` need not be specified for a particular `Interface_port_relationship`.

4.2.174.2 `related`

The `related` specifies the second of the two `Interface_port` (see 4.2.171) objects related by the `Interface_port_relationship`.

See 4.3.1362 for the application assertion.

4.2.174.3 `relating`

The `relating` specifies the first of the two `Interface_port` (see 4.2.171) objects related by the `Interface_port_relationship`.

See 4.3.1363 for the application assertion.

4.2.174.4 `relation_type`

The `relation_type` specifies the meaning of the relationship. The value is either user defined or predefined.

The predefined value of `relation_type` is one of the following:

- `decomposition`;
- `derivation`.

NOTE See 4.2.174.4.1 - 4.2.174.4.2 for the definition of each predefined value for `relation_type`.

ISO 10303-212:2001(E)

4.2.174.4.1 decomposition

decomposition: The `Interface_port_relationship` defines a relationship where the `Interface_port` (see 4.2.171) is one of the components into which the relating `Interface_port` (see 4.2.171) is decomposed.

4.2.174.4.2 derivation

derivation: The `Interface_port_relationship` defines a deriving relationship where the related `Interface_port` (see 4.2.171) is based on the relating `Interface_port` (see 4.2.171).

4.2.175 Interface_terminal

An `Interface_terminal` defines a single access point for a piece of equipment.

The data associated with an `Interface_terminal` are the following:

- description;
- id;
- `interface_terminal_of`;
- `maximum_number_of_conductors`;
- uses.

4.2.175.1 description

The description specifies an alphanumerical string containing human-interpretable text that gives further details about the `Interface_terminal`.

The description need not be specified for a particular `Interface_terminal`.

4.2.175.2 id

The id specifies the identifier of the `Interface_terminal`.

4.2.175.3 interface_terminal_of

The `interface_terminal_of` specifies the `Design_discipline_item_definition` (see 4.2.86) to which the `Interface_terminal` is assigned.

See 4.3.1364 for the application assertion.

4.2.175.4 maximum_number_of_conductors

The `maximum_number_of_conductors` specifies the maximum amount of wires or cables that may be connected to the associated `Terminal` (see 4.2.338).

The `maximum_number_of_conductors` need not be specified for a particular `Interface_terminal`.

4.2.175.5 uses

The uses specifies the Terminal (see 4.2.338) in the next lower level of the hierarchy onto which the Interface_terminal is mapped.

See 4.3.1365 for the application assertion.

4.2.176 Interface_terminal_connection

An Interface_terminal_connection is a type of Connectivity_definition (see 4.2.61) that is a link between Interface_terminal (see 4.2.174) objects that are connected internally of the equipment.

NOTE The Interface_terminal_connection allows one to specify the internal connections between the access nodes of a Design_discipline_item_definition (see 4.2.86) without the need to specify the internal structure of the piece of equipment.

EXAMPLE In Figure 15 an internally wired 9-pin connector is shown. Every odd pin is connected to ground. The pins are modelled as Interface_terminal (see 4.2.174) objects that are linked by four Interface_terminal_connection objects. The connection to ground is provided by a Connection (see 4.2.59) object.

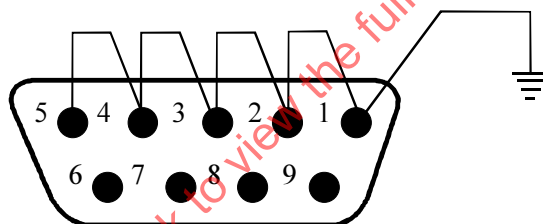

Figure 15 - Internally wired connector

The data associated with an Interface_terminal_connection are the following:

— connected_interface_terminal.

4.2.176.1 connected_interface_terminal

The connected_interface_terminal specifies the linked Interface_terminal (see 4.2.174) objects.

See 4.3.1366 for the application assertion.

4.2.177 Interface_terminal_relationship

A Interface_terminal_relationship is the relation between two Interface_terminal (see 4.2.174) objects.

ISO 10303-212:2001(E)

The data associated with a `Interface_terminal_relationship` are the following:

- description;
- related;
- relating;
- `relation_type`.

4.2.177.1 description

The description specifies an alphanumeric string containing human-interpretable text that gives further details about the `Interface_terminal_relationship`.

The description need not be specified for a particular `Interface_terminal_relationship`.

4.2.177.2 related

The related specifies the second of the two `Interface_terminal` (see 4.2.174) objects related by the `Interface_terminal_relationship`.

See 4.3.1367 for the application assertion.

4.2.177.3 relating

The relating specifies the first of the two `Interface_terminal` (see 4.2.174) objects related by the `Interface_terminal_relationship`.

See 4.3.1368 for the application assertion.

4.2.177.4 relation_type

The `relation_type` specifies the meaning of the relationship. The value is either user defined or predefined.

The predefined value of `relation_type` is one of the following:

- decomposition;
- derivation.

NOTE See 4.2.177.4.1 - 4.2.177.4.2 for the definition of each predefined value for `relation_type`.

4.2.177.4.1 decomposition

decomposition: The `Interface_terminal_relationship` defines a relationship where the related `Interface_terminal` (see 4.2.174) is one of the components into which the relating `Interface_terminal` (see 4.2.174) is divided.

4.2.177.4.2 derivation

derivation: The `Interface_terminal_relationship` defines a deriving relationship where the related `Interface_terminal` (see 4.2.174) is based on the relating `Interface_terminal` (see 4.2.174).

4.2.178 Interval_of_time

An `Interval_of_time` is a period of time.

The data associated with a `Interval_of_time` are the following:

- `end_definition`;
- `start_definition`.

4.2.178.1 end_definition

The `end_definition` defines the end of the `Interval_of_time`, either by referring to a bound, or specifying the extend of the `Interval_of_time` by a `Duration` (see 4.2.126). If the `end_definition` refers to an `Event_reference` (see 4.2.130) or `Date_time` (see 4.2.79), this particular bound of the resulting interval is excluded from it.

There shall be exactly one object that defines the `end_definition` for an `Interval_of_time`.

Each `end_definition` may be one of the following: `Date_time` (see 4.2.79), `Duration` (see 4.2.126), or `Event_reference` (see 4.2.130).

See 4.3.1369, 4.3.1371, and 4.3.1372 for the application assertions.

4.2.178.2 start_definition

The `start_definition` defines the beginning of the `Interval_of_time`. The bound specified by the `start_definition` is included in the resulting interval.

There shall be exactly one object that defines the `start_definition` for an `Interval_of_time`.

Each `start_definition` may be one of the following: `Date_time` (see 4.2.79) or `Event_reference` (see 4.2.130).

See 4.3.1370 and 4.3.1373 for the application assertions.

4.2.179 Item

An `Item` is a thing produced or intended to be produced, set up, designed, or installed in an electrotechnical system. It can be either a single component or an assembly of arbitrary complexity.

ISO 10303-212:2001(E)

EXAMPLE The electrotechnical equipment controlling a whole plant can be considered to be an Item.

NOTE Information about Item objects shall not be misused to lay down data that is covered elsewhere in this part of ISO 10303.

The data associated with an Item are the following:

- description;
- extended_designation;
- id;
- name.

4.2.179.1 description

The description specifies an alphanumeric string containing human-interpretable text that gives further details about the Item.

The description need not be specified for a particular Item.

4.2.179.2 extended_designation

The extended_designation specifies a label for the Item that may be visualized in schematics.

NOTE The label assigned through extended_designation shall be identical to the label assigned by the 'id' attribute.

The extended_designation need not be specified for a particular Item.

See 4.3.1374 for the application assertion.

4.2.179.3 id

The id specifies the identifier of the Item.

4.2.179.4 name

The name specifies a speaking designation of the Item.

4.2.180 Item_definition_relationship

An Item_definition_relationship is a relationship between two Design_discipline_item_definition (see 4.2.86) objects.

The data associated with an Item_definition_relationship are the following:

- description;
- related;
- relating;
- relation_type.

4.2.180.1 description

The description specifies an alphanumeric string containing human-interpretable text that gives further details about the Item_definition_relationship.

The description need not be specified for a particular Item_definition_relationship.

4.2.180.2 related

The related specifies the second of the two Design_discipline_item_definition (see 4.2.86) objects related by the Item_definition_relationship.

See 4.3.1375 for the application assertion.

4.2.180.3 relating

The relating specifies the first of the two Design_discipline_item_definition (see 4.2.86) objects related by the Item_definition_relationship.

See 4.3.1376 for the application assertion.

4.2.180.4 relation_type

The relation_type specifies the meaning of the relationship. The value is either user defined or predefined.

The predefined value of relation_type is one of the following:

- alternate;
- derivation;
- substitution.

NOTE 1 See 4.2.180.4.1 - 4.2.180.4.3 for the definition of each predefined value for relation_type.

4.2.180.4.1 alternate

alternate: The Item_definition_relationship defines a relationship where the related Design_discipline_item_definition (see 4.2.86) is a possible substitute to the relating Design_discipline_item_definition (see 4.2.86).

ISO 10303-212:2001(E)

NOTE 2 This concept refers to the possibility to replace the Design_discipline_item_definition (see 4.2.86). The actual replacement is addressed by 'substitution'.

4.2.180.4.2 derivation

derivation: The Item_definition_relationship defines a deriving relationship where the related Design_discipline_item_definition (see 4.2.86) is based on the relating Design_discipline_item_definition (see 4.2.86).

4.2.180.4.3 substitution

substitution: The Item_definition_relationship defines a relationship where the related Design_discipline_item_definition (see 4.2.86) replaces the relating Design_discipline_item_definition (see 4.2.86).

4.2.181 Item_identification

An Item_identification is a sequence of alphanumeric characters that labels an Item (see 4.2.178).

NOTE 1 If equipment is to be repaired or exchanged, the Item_identification allows the determination of the exact type of equipment.

NOTE 2 An Item_identification of an Item (see 4.2.178) can be unique to each organization.

EXAMPLE The order number may serve as an Item_identification.

The data associated with an Item_identification are the following:

- coding_type;
- id.

4.2.181.1 coding_type

The coding_type specifies the syntax used for the id.

The coding_type need not be specified for a particular Item_identification.

See 4.3.1377 for the application assertion.

4.2.181.2 id

The id specifies the identifier of the Item_identification.

4.2.182 Item_presentation

An Item_presentation is the association of an item to its presentation.

The data associated with an `Item_presentation` are the following:

- `id`;
- `presented_item`;
- `presenting_item`.

4.2.182.1 `id`

The `id` specifies the identifier of the `Item_presentation`.

The `id` need not be specified for a particular `Item_presentation`.

4.2.182.2 `presented_item`

The `presented_item` specifies the item that is presented.

Each `presented_item` may be one of the following: `Activity` (see 4.2.1), `Activity_element` (see 4.2.2), `Alias_identification` (see 4.2.9), `Classification_association` (see 4.2.46), `Classification_attribute` (see 4.2.47), `Classification_system` (see 4.2.48), `Connecting_line` (see 4.2.58), `Connectivity_definition` (see 4.2.61), `Cross_reference` (see 4.2.64), `Data_element` (see 4.2.70), `Data_element_definition` (see 4.2.72), `Data_element_specification` (see 4.2.75), `Design_discipline_item_definition` (see 4.2.86), `Device` (see 4.2.88), `Document` (see 4.2.101), `Document_version` (see 4.2.114), `Free_segment` (see 4.2.144), `Function_definition` (see 4.2.145), `Function_interface` (see 4.2.147), `Function_unit` (see 4.2.148), `Function_version` (see 4.2.150), `Functional_connectivity_definition` (see 4.2.152), `Functionality` (see 4.2.155), `General_classification` (see 4.2.156), `Generic_note` (see 4.2.159), `Interface` (see 4.2.170), `Interface_port` (see 4.2.171), `Interface_terminal` (see 4.2.174), `Item` (see 4.2.178), `Item_identification` (see 4.2.180), `Item_version` (see 4.2.182), `Location` (see 4.2.192), `Node` (see 4.2.208), `Notification` (see 4.2.215), `Object_designation` (see 4.2.217), `Page_connector_presentation` (see 4.2.228), `Path` (see 4.2.232), `Path_node` (see 4.2.233), `Physical_instance` (see 4.2.243), `Port` (see 4.2.247), `Process_variable` (see 4.2.260), `Project` (see 4.2.271), `Route` (see 4.2.290), `Routed_segment` (see 4.2.293), `Section` (see 4.2.296), `Section_end` (see 4.2.297), `Section_interface` (see 4.2.298), `Security_classification` (see 4.2.301), `Security_level` (see 4.2.302), `Signal` (see 4.2.309), `Signal_value` (see 4.2.313), `Technical_system` (see 4.2.336), `Terminal` (see 4.2.338), `Work_order` (see 4.2.364), or `Work_request` (see 4.2.365).

See 4.3.1378, 4.3.1379, 4.3.1380, 4.3.1382, 4.3.1383, 4.3.1384, 4.3.1385, 4.3.1386, 4.3.1387, 4.3.1388, 4.3.1389, 4.3.1390, 4.3.1391, 4.3.1392, 4.3.1393, 4.3.1394, 4.3.1395, 4.3.1396, 4.3.1397, 4.3.1398, 4.3.1399, 4.3.1400, 4.3.1401, 4.3.1402, 4.3.1403, 4.3.1404, 4.3.1405, 4.3.1406, 4.3.1407, 4.3.1408, 4.3.1409, 4.3.1410, 4.3.1411, 4.3.1412, 4.3.1413, 4.3.1414, 4.3.1415, 4.3.1416, 4.3.1417, 4.3.1418, 4.3.1419, 4.3.1420, 4.3.1421, 4.3.1422, 4.3.1423, 4.3.1424, 4.3.1425, 4.3.1426, 4.3.1427, 4.3.1428, 4.3.1429, 4.3.1430, 4.3.1431, 4.3.1432, and 4.3.1433 for the application assertions.

4.2.182.3 `presenting_item`

The `presenting_item` specifies the `Annotation_element` (see 4.2.15) used to display the item.

See 4.3.1381 for the application assertion.

4.2.183 `Item_version`

ISO 10303-212:2001(E)

An `Item_version` is a particular version of an `Item` (see 4.2.178).

NOTE Several versions for the same `Item` (see 4.2.178) may exist at one point in time. The information about valid and invalid versions is handled by the associated organizational data.

The data associated with an `Item_version` are the following:

- `associated_item`;
- `description`;
- `version_id`.

4.2.183.1 associated_item

The `associated_item` specifies the associated `Item` (see 4.2.178) object.

See 4.3.1434 for the application assertion.

4.2.183.2 description

The `description` specifies an alphanumerical string containing human-interpretable text that gives further details about the `Item_version`.

The `description` need not be specified for a particular `Item_version`.

4.2.183.3 version_id

The `version_id` specifies versioning information for the `Item_version`.

4.2.184 Item_version_relationship

An `Item_version_relationship` is a relationship between two `Item_version` (see 4.2.182) objects.

The data associated with an `Item_version_relationship` are the following:

- `description`;
- `related`;
- `relating`;
- `relation_type`.

4.2.184.1 description

The `description` specifies an alphanumerical string containing human-interpretable text that gives further details about the `Item_version_relationship`.

The `description` need not be specified for a particular `Item_version_relationship`.

4.2.184.2 related

The related specifies the second of the two `Item_version` (see 4.2.182) objects related by the `Item_version_relationship`.

See 4.3.1435 for the application assertion.

4.2.184.3 relating

The relating specifies the first of the two `Item_version` (see 4.2.182) objects related by the `Item_version_relationship`.

See 4.3.1436 for the application assertion.

4.2.184.4 relation_type

The `relation_type` specifies the meaning of the relationship. The value is either user defined or predefined.

The predefined value of `relation_type` is one of the following:

- derivation;
- hierarchy;
- sequence;
- supplied item.

NOTE See 4.2.184.4.1 - 4.2.184.4.4 for the definition of each predefined value for `relation_type`.

4.2.184.4.1 derivation

derivation: The `Item_version_relationship` defines a deriving relationship where the related `Item_version` (see 4.2.182) is based on the relating `Item_version` (see 4.2.182) which is an earlier version of the same or of a different `Item` (see 4.2.178).

4.2.184.4.2 hierarchy

hierarchy: The `Item_version_relationship` defines a hierarchical relationship where the related `Item_version` (see 4.2.182) is a subversion of the relating `Item_version` (see 4.2.182).

EXAMPLE Revision 1.1 and 1.2 of a drive.

4.2.184.4.3 sequence

sequence: The `Item_version_relationship` defines a succession of versions where the relating `Item_version` (see 4.2.182) is the preceding version, and the related `Item_version` (see 4.2.182) is the following version. For an `Item_version` (see 4.2.182), there shall be, at the most, one `Item_version_relationship` of this relation type as relating and, at most, one `Item_version_relationship` of this relation type as related.

4.2.184.4.4 supplied item

ISO 10303-212:2001(E)

supplied item: The `Item_version_relationship` defines a relationship between two `Item_version` (see 4.2.182) objects representing the same item in different organizational contexts.

EXAMPLE A piece of equipment that is identified in a company by the identifier 'C425' and `version_id` 'V2.0' is identified by its supplier as '2X45', `version_id` 'V3.2'.

4.2.185 Language

The `Language` specifies a language spoken by human beings to communicate with each other verbally or in written form.

The data associated with a `Language` are the following:

- `country_code`;
- `language_code`.

4.2.185.1 country_code

The `country_code` specifies the country, as addition to the `language`, according to the alpha-2 code specified in ISO 3166-1.

EXAMPLE Possible values for `country_code` are, e.g., 'GB' for the United Kingdom or 'US' for the United States of America.

The `country_code` need not be specified for a particular `Language`.

4.2.185.2 language_code

The `language_code` specifies the language of the text information in the Alpha-3 bibliographic code specified in ISO 639-2.

EXAMPLE Possible values for `language_code` are, e.g., 'eng' for English, 'fre' for French, 'rus' for Russian, or 'ger' for German.

4.2.186 Layer

A `Layer` is a mechanism for the organization of CAD elements. Within the CAD model, one or more levels are positioned in a stacked arrangement. These levels may have specific, defined uses and may be displayed as desired by the user.

The data associated with a Layer are the following:

- description;
- element_visibility;
- layer_id.

4.2.186.1 description

The description specifies an alphanumeric string containing human-interpretable text that gives further details about the Layer.

The description need not be specified for a particular Layer.

4.2.186.2 element_visibility

The element_visibility specifies whether or not the elements assigned to the layer are displayed in the visual presentation of the drawing.

See 4.3.1437 for the application assertion.

4.2.186.3 layer_id

The layer_id specifies the identification of a particular layer.

4.2.187 Leader

A Leader is a type of Directed_curve (see 4.2.99) that directs a dimension, a note, or a symbol to the intended place or point on a feature appearing on the drawing.

The data associated with a Leader are the following:

- target_element.

4.2.187.1 target_element

The target_element specifies the annotation element that is the target for the leader.

The target_element need not be specified for a particular Leader.

See 4.3.1438 for the application assertion.

4.2.188 Leader_directed_dimension

A Leader_directed_dimension is a type of Dimension (see 4.2.93) that is the graphical presentation of a dimension value and is guided to the feature being dimensioned with a leader.

ISO 10303-212:2001(E)

The data associated with a `Leader_directed_dimension` are the following:

- `component`.

4.2.188.1 component

The `component` specifies the leader that visually directs the callout to the element.

See 4.3.1439 for the application assertion.

4.2.189 Leader_terminator

A `Leader_terminator` is a graphical symbol that is applied to a leader and used to identify the endpoint or point of application of the directed annotation.

The data associated with a `Leader_terminator` are the following:

- `line`;
- `symbol`.

4.2.189.1 line

The `line` specifies the leader to which the symbol applies.

See 4.3.1441 for the application assertion.

4.2.189.2 symbol

The `symbol` specifies an `Annotation_symbol` (see 4.2.20) that is used to identify the endpoint or point of application of the directed annotation.

See 4.3.1440 for the application assertion.

4.2.190 Line_font

A `Line_font` is a defined pattern of visible and invisible segments applied to a curve in a repetitive manner.

Each `Line_font` is either an `Externally_defined_line_font` (see 4.2.134), a `Predefined_line_font` (see 4.2.254), or a `User_defined_line_font` (see 4.2.353).

4.2.191 Linear_dimension

A `Linear_dimension` is a type of `Dimension` (see 4.2.93) that is the graphical presentation of a value of linear distance measured between two points along a straight path.

The data associated with a Linear_dimension are the following:

- component;
- extent.

4.2.191.1 component

The component specifies the projection lines that shows the extension of the points, lines, or surfaces that bound the measurement.

See 4.3.1443 for the application assertion.

4.2.191.2 extent

The extent specifies the dimension line that graphically presents where the dimension value applies.

See 4.3.1442 for the application assertion.

4.2.192 Linear_pattern_location

A Linear_pattern_location is a means to locate repeating patterns along the centre-line of a product.

The data associated with a Linear_pattern_location are the following:

- distance;
- orientation;
- start_location.

4.2.192.1 distance

The distance specifies the span between two neighbouring patterns.

4.2.192.2 orientation

The orientation specifies the direction of the positive z axis of the Linear_pattern_location.

The orientation need not be specified for a particular Linear_pattern_location.

4.2.192.3 start_location

The start_location specifies the location of the first pattern.

See 4.3.1444 for the application assertion.

4.2.193 Location

A Location is a region of space.

ISO 10303-212:2001(E)

NOTE 1 A Location may provide specific environmental conditions that applies to the equipment that is situated at the Location.

NOTE 2 A Location can be used to reserve space for equipment that is not known yet. Therefore it can be appropriate to define a Location without assigning physical or abstract items to it.

NOTE 3 A Location can be used to support mechanical interference detection.

The data associated with a Location are the following:

- `defining_item`;
- `description`;
- `extended_designation`;
- `id`;
- `local_coordinate_space`;
- `position`;
- `version_id`.

4.2.193.1 `defining_item`

The `defining_item` specifies that the Location has the shape and size of the object which is associated through the '`defining_item`' attribute.

NOTE 4 The shape definition of an equipment item used to specify the shape of the Location needs to be unambiguous.

NOTE 5 The shape need not be explicitly specified through an associated Shape (see 4.2.306) object.

Each `defining_item` may be one of the following: `Design_discipline_item_definition` (see 4.2.86), `Physical_instance` (see 4.2.243), `Product_component` (see 4.2.265), `Single_device` (see 4.2.314), `Specified_device` (see 4.2.328), or `Technical_system` (see 4.2.336).

See 4.3.1447, 4.3.1450, 4.3.1451, 4.3.1452, 4.3.1453, and 4.3.1454 for the application assertions.

4.2.193.2 `description`

The `description` specifies an alphanumeric string containing human-interpretable text that gives further details about the Location.

The `description` need not be specified for a particular Location.

4.2.193.3 `extended_designation`

The `extended_designation` specifies a structured label for the Location.

NOTE 6 The label assigned through `extended_designation` shall be identical to the label assigned by the 'id' attribute.

The `extended_designation` need not be specified for a particular Location.

See 4.3.1449 for the application assertion.

4.2.193.4 id

The `id` specifies the identifier of the Location.

4.2.193.5 local_coordinate_space

The `local_coordinate_space` specifies the coordinate system of the Location.

The `local_coordinate_space` need not be specified for a particular Location.

See 4.3.1445 for the application assertion.

4.2.193.6 position

The `position` specifies the spatial position of the Location. If a local coordinate system exists, the 'position' attributes specifies its origin.

The `position` need not be specified for a particular Location.

Each `position` may be one of the following: `Cartesian_point` (see 4.2.37) or `Gis_position` (see 4.2.162).

See 4.3.1446 and 4.3.1448 for the application assertions.

4.2.193.7 version_id

The `version_id` specifies versioning information for the Location.

The `version_id` need not be specified for a particular Location.

4.2.194 Location_assignment

A `Location_assignment` is an association of a Location (see 4.2.192) with an physical or abstract item.

ISO 10303-212:2001(E)

The data associated with a Location_assignment are the following:

- assigned_location;
- associated_item;
- description;
- role.

4.2.194.1 assigned_location

The assigned_location specifies the associated Location (see 4.2.192) object.

See 4.3.1461 for the application assertion.

4.2.194.2 associated_item

The associated_item specifies the item that is related to the Location (see 4.2.192).

Each associated_item may be one of the following: Connectivity_definition (see 4.2.61), Design_discipline_item_definition (see 4.2.86), Device (see 4.2.88), Function_definition (see 4.2.145), Function_unit (see 4.2.148), Functional_connectivity_definition (see 4.2.152), Physical_instance (see 4.2.243), Port (see 4.2.247), Product_component (see 4.2.265), Signal (see 4.2.309), Technical_system (see 4.2.336), or Terminal (see 4.2.338).

See 4.3.1455, 4.3.1456, 4.3.1457, 4.3.1458, 4.3.1459, 4.3.1460, 4.3.1462, 4.3.1463, 4.3.1464, 4.3.1465, 4.3.1466, and 4.3.1467 for the application assertions.

4.2.194.3 description

The description specifies an alphanumerical string containing human-interpretable text that gives further details about the Location_assignment.

The description need not be specified for a particular Location_assignment.

4.2.194.4 role

The role specifies the relationship between the location and the accommodated item. The value is either user defined or predefined.

The predefined value of role is one of the following:

- accommodation.

NOTE See 4.2.194.4.1 for the definition of each predefined value for role.

4.2.194.4.1 accommodation

accommodation: The accommodation specifies that the referenced item is situated in the associated location.

4.2.195 Location_relationship

A Location_relationship is the relation between two Location (see 4.2.192) objects.

Each Location_relationship is either a General_location_relationship (see 4.2.158), a Hierarchical_location_relationship (see 4.2.168), or a Neighbourhood_location_relationship (see 4.2.205).

The data associated with an Location_relationship are the following:

— related;

— relating.

4.2.195.1 related

The related specifies the second of the two Location (see 4.2.192) objects related by the Location_relationship.

See 4.3.1468 for the application assertion.

4.2.195.2 relating

The relating specifies the first of the two Location (see 4.2.192) objects related by the Location_relationship.

See 4.3.1469 for the application assertion.

4.2.196 Logical_value

A Logical_value is the representation of a 'true', 'false', or 'unknown' value.

The data associated with a Logical_value are the following:

— value_of_logical_value.

4.2.196.1 value_of_logical_value

The value_of_logical_value specifies the value of a logical variable.

4.2.197 Lot_configuration

A Lot_configuration is a type of Manufacturing_configuration (see 4.2.198) that is planned to apply from a given batch of aspects of a part.

The data associated with a Lot_configuration are the following:

— lot_id;

— lot_size.

4.2.197.1 lot_id

ISO 10303-212:2001(E)

The `lot_id` specifies the identification of the batch of aspects of a part to which the `Lot_configuration` applies.

4.2.197.2 `lot_size`

The `lot_id` specifies the size of the batch of aspects of a part that the `Lot_configuration` applies to.

4.2.198 `Make_from_relationship`

A `Make_from_relationship` is a type of `Item_definition_relationship` (see 4.2.179) that is a relationship between a `Design_discipline_item_definition` (see 4.2.86) which provides the definition of a raw material, or of a semi-finished part and a `Design_discipline_item_definition` (see 4.2.86) which provides the definition of an object manufactured out of that material, or semi-finished part. The inherited attribute 'related' specifies the raw material or the semi-finished part, and the inherited attribute 'relating' specifies the manufactured part.

4.2.199 `Manufacturing_configuration`

A `Manufacturing_configuration` is the association of a `Product_identification` (see 4.2.268), `Product_design` (see 4.2.267), or an `Item_version` (see 4.2.182) with a `Device` (see 4.2.88).

Each `Manufacturing_configuration` is either a `Dated_configuration` (see 4.2.82), a `Lot_configuration` (see 4.2.196), or a `Serial_configuration` (see 4.2.304).

The data associated with a `Manufacturing_configuration` are the following:

- `concerned_organization`;
- `configured_element`;
- `is_solution_for`.

4.2.199.1 `concerned_organization`

The `concerned_organization` specifies the `Organization` (see 4.2.223) in which the `Manufacturing_configuration` is valid. The case where the `concerned_organization` is an empty set means that the `Manufacturing_configuration` regards any organization that may consider the 'configured_element'.

See 4.3.1471 for the application assertion.

4.2.199.2 `configured_element`

The `configured_element` specifies an `Device` (see 4.2.88) that is controlled by a `Manufacturing_configuration`.

See 4.3.1470 for the application assertion.

4.2.199.3 `is_solution_for`

The `is_solution_for` specifies the characteristic or combination of characteristics for which the `Device` (see 4.2.88) provides a technical solution.

See 4.3.1472 for the application assertion.

4.2.200 Marking

A Marking is a sign applied to a piece of equipment used to give additional information about the part.

The data associated with a Marking are the following:

- character_string;
- figure;
- marked_device;
- marking_system;
- meaning;
- position.

4.2.200.1 character_string

The character_string specifies the list of characters that compose the marking applied to the piece of equipment.

NOTE If the marking consists of pictorial elements the 'character_string' attribute contains text that identifies the pictures.

EXAMPLE 1 A wire is marked with W001 which is the designator of this particular wire. The 'character_string' attribute contains the string 'W001'.

EXAMPLE 2 A high voltage cable is marked with a warning symbol. The 'character_string' attribute contains the string 'Warning label 47-BA'.

4.2.200.2 figure

The figure specifies the appearance of the Marking, which includes information about the colour and form of the Marking.

The figure need not be specified for a particular Marking.

See 4.3.1473 for the application assertion.

4.2.200.3 marked_device

The marked_device specifies the Device (see 4.2.88) the Marking is applied to.

See 4.3.1479 for the application assertion.

4.2.200.4 marking_system

The marking_system specifies the Classification_system (see 4.2.48) that shall be used to interpret the Marking.

See 4.3.1475 for the application assertion.

4.2.200.5 meaning

The meaning specifies the content of the Marking.

Each meaning may be one of the following: Data_element (see 4.2.70) or Generic_note (see 4.2.159).

See 4.3.1476 and 4.3.1477 for the application assertions.

4.2.200.6 position

The position specifies the spot where the Marking is applied to the Device (see 4.2.88).

Each position may be one of the following: Cartesian_point (see 4.2.37) or Linear_pattern_location (see 4.2.191).

See 4.3.1474 and 4.3.1478 for the application assertions.

4.2.201 Mass

A Mass is the quantity of matter a component contains.

The data associated with a Mass are the following:

— value_of_mass.

4.2.201.1 value_of_mass

The value_of_mass specifies the value that indicates the mass.

See 4.3.1480 for the application assertion.

4.2.202 Material

A Material is the matter from which a component is made.

The data associated with a Material are the following:

— substance.

4.2.202.1 substance

The substance specifies human-interpretable information characterizing the matter.

4.2.203 Model_placed_annotation

A `Model_placed_annotation` is a type of `Draughting_annotation` (see 4.2.116) that is located in the coordinate system of the draughting shape model and is subject to view transformations for display.

The data associated with a `Model_placed_annotation` are the following:

- `annotation_layers`;
- `annotation_visibility`.

4.2.203.1 `annotation_layers`

The `annotation_layers` specifies the layers that contain the annotation.

See 4.3.1481 for the application assertion.

4.2.203.2 `annotation_visibility`

The `annotation_visibility` specifies whether or not each piece of annotation placed within the draughting shape model is visible.

See 4.3.1482 for the application assertion.

4.2.204 `Mounting_features`

A `Mounting_features` is the description of the methods that can be used to attach one component to its counterpart.

The data associated with a `Mounting_features` are the following:

- `fixture`.

4.2.204.1 `fixture`

The `fixture` specifies human-interpretable information describing the mounting features.

4.2.205 `Multi_language_note`

A `Multi_language_note` is a type of `Set_of_notes` (see 4.2.305) that is a group of `Note` (see 4.2.210) objects. Each `Note` (see 4.2.210) is authored in its individual language. In all cases the meaning of the text contained in the `'text_of_note'` attribute of the grouped `Note` (see 4.2.210) objects is the same.

NOTE A `Multi_language_note` shall only be associated to an attribute, not to a whole item.

EXAMPLE A `Multi_language_note` grouping two `Note` (see 4.2.210) objects with the content `'Attention - High voltage'` and `'Achtung - Hochspannung'`.

4.2.206 `Neighbourhood_location_relationship`

A `Neighbourhood_location_relationship` is a type of `Location_relationship` (see 4.2.194) that is the relation between two `Location` (see 4.2.192) objects that specifies the spatial arrangement between the related `Location` (see 4.2.192) objects.

ISO 10303-212:2001(E)

The data associated with an `Neighbourhood_location_relationship` are the following:

— `relation_type`.

4.2.206.1 `relation_type`

The `relation_type` specifies the meaning of the relationship. The value is either user defined or predefined.

NOTE The relating Location (see 4.2.192) is a part of the related Location (see 4.2.192).

The predefined value of `relation_type` is one of the following:

- `above`;
- `across`;
- `adjoining`;
- `around`;
- `outside`.

NOTE See 4.2.206.1.1 - 4.2.206.1.5 for the definition of each predefined value for `relation_type`.

4.2.206.1.1 `above`

`above`: The `Neighbourhood_location_relationship` defines a relationship where the related Location (see 4.2.192) is on top of the relating Location (see 4.2.192).

4.2.206.1.2 `across`

`across`: The `Neighbourhood_location_relationship` defines a relationship where the related Location (see 4.2.192) goes from one side to another side of the relating Location (see 4.2.192).

EXAMPLE A high-voltage cable may run across a private property.

4.2.206.1.3 `adjoining`

`adjoining`: The `Neighbourhood_location_relationship` defines a relationship where the related Location (see 4.2.192) is located at the boundary of the relating Location (see 4.2.192).

4.2.206.1.4 `around`

`around`: The `Neighbourhood_location_relationship` defines a relationship where the related Location (see 4.2.192) specifies an area that surrounds the relating Location (see 4.2.192).

NOTE The relating Location (see 4.2.192) is not a part of the related Location (see 4.2.192).

4.2.206.1.5 outside

outside: The Neighbourhood_location_relationship defines a deriving relationship where the related Location (see 4.2.192) is external the relating Location (see 4.2.192).

4.2.207 Network

A Network is a type of Functional_connectivity_definition (see 4.2.152) that is the link between Port (see 4.2.247) objects with the intention to allow the flow of information.

NOTE A Network may be decomposed into its constituents. The information about the constituents is specified through Functional_connectivity_definition_relationship (see 4.2.153) of type 'decomposition'.

EXAMPLE 2 bit wide parallel bus is described as a Network consisting of 32 underlying Network objects. The lower level Network objects are related to the upper level Network object through Functional_connectivity_definition_relationship (see 4.2.153) objects of type 'decomposition'.

The data associated with a Network are the following:

— connected_port.

4.2.207.1 connected_port

The connected_port specifies the Port (see 4.2.247) objects that are joined with each other within a Network.

See 4.3.1483 for the application assertion.

4.2.208 Next_higher_assembly

A Next_higher_assembly is a type of Assembly_component_relationship (see 4.2.26) that is a relation where the attribute related specifies a constituent of an assembly, and the attribute relating specifies the immediate parent assembly of the constituent. A constituent may be a single part or an assembly.

EXAMPLE The assembly 'motor' may be assembled of single parts. The belt conveyor assembly is formed of assemblies.

4.2.209 Node

A Node is a named position that is of interest for the placement of equipment.

NOTE 1 A Route (see 4.2.290) is understood as a sequence of vertices and edges, where the vertices are Node objects.

NOTE 2 A Node does not have real world coordinates unless a Path_node (see 4.2.233) assigns them to the Node.

ISO 10303-212:2001(E)

The data associated with a Node are the following:

- assigned_location;
- description;
- id;
- implemented_by;
- position.

4.2.209.1 assigned_location

The assigned_location specifies the Location (see 4.2.192) that contains the Node.

See 4.3.1485 for the application assertion.

4.2.209.2 description

The description specifies an alphanumeric string containing human-interpretable text that gives further details about the Node.

The description need not be specified for a particular Node.

4.2.209.3 id

The id specifies the identifier of the Node.

4.2.209.4 implemented_by

The implemented_by specifies the Device (see 4.2.88) objects that are used to implement the Node.

EXAMPLE A node can be implemented by elements such as cable clips or fasteners.

See 4.3.1484 for the application assertion.

4.2.209.5 position

The position specifies the placement of the Node.

The position need not be specified for a particular Node.

See 4.3.1486 for the application assertion.

4.2.210 Node_relationship

A Node_relationship is the relation between two Node (see 4.2.208) objects.

The data associated with an Node_relationship are the following:

- description;
- related;
- relating;
- relation_type.

4.2.210.1 description

The description specifies an alphanumeric string containing human-interpretable text that gives further details about the Node_relationship.

The description need not be specified for a particular Node_relationship.

4.2.210.2 related

The related specifies the second of the two Node (see 4.2.208) objects related by the Node_relationship.

See 4.3.1487 for the application assertion.

4.2.210.3 relating

The relating specifies the first of the two Node (see 4.2.208) objects related by the Node_relationship.

See 4.3.1488 for the application assertion.

4.2.210.4 relation_type

The relation_type specifies the meaning of the relationship. The value is either user defined or predefined.

ISO 10303-212:2001(E)

The predefined value of `relation_type` is one of the following:

- alternate;
- decomposition;
- derivation;
- substitution.

NOTE 1 See 4.2.210.4.1 - 4.2.210.4.4 for the definition of each predefined value for `relation_type`.

4.2.210.4.1 alternate

alternate: The `Node_relationship` defines a relationship where the related `Node` (see 4.2.208) is a possible substitute to the relating `Node` (see 4.2.208).

NOTE 2 This allows one to map `Node` (see 4.2.208) objects onto each other.

NOTE 3 This concept refers to the possibility to replace the `Node` (see 4.2.208). The actual replacement is addressed by 'substitution'.

4.2.210.4.2 decomposition

decomposition: The `Node_relationship` defines a relationship where the related `Node` (see 4.2.208) is one of the components into which the relating `Node` (see 4.2.208) is divided up.

4.2.210.4.3 derivation

derivation: The `Node_relationship` defines a deriving relationship where the related `Node` (see 4.2.208) is based on the relating `Node` (see 4.2.208).

4.2.210.4.4 substitution

substitution: The `Node_relationship` defines a relationship where the related `Node` (see 4.2.208) replaces the relating `Node` (see 4.2.208).

4.2.211 Note

A `Note` is a type of `Generic_note` (see 4.2.159) that is human-interpretable information intended to give further details on a specific part of an electrotechnical system. By using notes, explanatory information can be added to the product data.

The data associated with a `Note` are the following:

- kind;
- language_specification;
- text_of_note.

4.2.211.1 kind

The kind specifies the category of the Note. The value is either user defined or predefined.

The predefined value of kind is one of the following:

- additional language dependent string;
- assembly instruction;
- explanatory note;
- installation instruction;
- manufacturing instruction;
- operating instruction;
- primary language dependent string.

NOTE See 4.2.211.1.1 - 4.2.211.1.7 for the definition of each predefined value for kind.

4.2.211.1.1 additional language dependent string

additional language dependent string: The textual information of the Note is phrased in a language other than the primary language.

4.2.211.1.2 assembly instruction

assembly instruction: The Note contains information about the assembly process of the equipment to which the Note is assigned.

4.2.211.1.3 explanatory note

explanatory note: The Note contains additional descriptive information about the data.

4.2.211.1.4 installation instruction

installation instruction: The Note contains information about the erection of the equipment.

4.2.211.1.5 manufacturing instruction

manufacturing instruction: The Note contains information about the manufacturing of the equipment.

4.2.211.1.6 operating instruction

operating instruction: The Note contains information about the functioning or handling of the equipment.

4.2.211.1.7 primary language dependent string

primary language dependent string: The textual information of the Note is phrased in the original language.

4.2.211.2 language_specification

ISO 10303-212:2001(E)

The language_specification specifies a language spoken by human beings to communicate with each other verbally or in written form. The language symbol given in ISO 639 shall be used.

See 4.3.1489 for the application assertion.

4.2.211.3 text_of_note

The text_of_note specifies human-interpretable information that shall be conveyed to the user.

4.2.212 Note_association

The Note_association is the relation between the annotation information and the physical or abstract item that is described. The purpose of this relationship is specified by the content of the attributes applied_attribute_name and role.

The data associated with a Note_association are the following:

- applied_attribute_name;
- assigned_note;
- associated_item;
- role.

4.2.212.1 applied_attribute_name

The applied_attribute_name specifies the attribute to which the assigned Note (see 4.2.210) applies.

The applied_attribute_name need not be specified for a particular Note_association.

4.2.212.2 assigned_note

The assigned_note specifies the annotation.

See 4.3.1547 for the application assertion.

4.2.212.3 associated_item

The associated_item specifies the item that is described by the associated annotation.

Each associated_item may be one of the following: Activity (see 4.2.1), Activity_method (see 4.2.3), Activity_relationship (see 4.2.5), Alias_identification (see 4.2.9), Alternate_item_relationship (see 4.2.11), Application_context (see 4.2.22), Approval_relationship (see 4.2.24), Assembly_component_relationship (see 4.2.26), Assembly_substitute_relationship (see 4.2.28), Cable_pull_information (see 4.2.33), Certification (see 4.2.38), Class_category_association (see 4.2.40), Class_condition_association (see 4.2.41), Class_inclusion_association (see 4.2.42), Class_specification_association (see 4.2.44), Class_structure_relationship (see 4.2.45), Classification_attribute (see 4.2.47), Classification_system (see 4.2.48), Classification_system (see 4.2.48), Complex_product (see 4.2.51), Complex_product_relationship (see 4.2.52), Composition_relationship (see 4.2.55), Configuration (see 4.2.56), Connectivity_allocation (see 4.2.60), Connectivity_definition (see 4.2.61), Connectivity_definition_relationship (see 4.2.62), Contract (see 4.2.63), Data_element (see

4.2.70), Data_element_association (see 4.2.71), Data_element_definition (see 4.2.72), Data_element_definition_relationship (see 4.2.73), Data_element_specification (see 4.2.75), Design_discipline_item_definition (see 4.2.86), Device (see 4.2.88), Device_relationship (see 4.2.89), Document (see 4.2.101), Document_file (see 4.2.106), Document_file_relationship (see 4.2.107), Document_version (see 4.2.114), Drawing_sheet (see 4.2.122), Drawing_view (see 4.2.125), Effectivity (see 4.2.127), Effectivity_relationship (see 4.2.129), Event_reference (see 4.2.130), External_library_reference (see 4.2.132), Free_segment (see 4.2.144), Function_definition (see 4.2.145), Function_definition_relationship (see 4.2.146), Function_interface (see 4.2.147), Function_unit (see 4.2.148), Function_unit_relationship (see 4.2.149), Function_version (see 4.2.150), Functional_connectivity_definition (see 4.2.152), Functional_connectivity_definition_relationship (see 4.2.153), Functional_unit_allocation (see 4.2.154), Functionality (see 4.2.155), General_classification (see 4.2.156), Interface (see 4.2.170), Interface_port (see 4.2.171), Interface_terminal (see 4.2.174), Item (see 4.2.178), Item_definition_relationship (see 4.2.179), Item_version (see 4.2.182), Location (see 4.2.192), Location_relationship (see 4.2.194), Marking (see 4.2.199), Material (see 4.2.201), Node (see 4.2.208), Node_relationship (see 4.2.209), Notification (see 4.2.213), Offered_function_allocation (see 4.2.220), Organization_relationship (see 4.2.225), Path (see 4.2.232), Path_node (see 4.2.233), Physical_assembly_relationship (see 4.2.241), Physical_instance (see 4.2.243), Port (see 4.2.247), Port_allocation (see 4.2.248), Preferred_item_allocation (see 4.2.258), Preferred_item_terminal_allocation (see 4.2.259), Process_variable (see 4.2.260), Product_class (see 4.2.263), Product_class_relationship (see 4.2.264), Product_identification (see 4.2.268), Product_specification (see 4.2.269), Product_structure_relationship (see 4.2.270), Project (see 4.2.271), Project_relationship (see 4.2.272), Requirement (see 4.2.285), Route (see 4.2.290), Route_relationship (see 4.2.291), Routed_segment (see 4.2.293), Section (see 4.2.296), Section_end (see 4.2.297), Section_interface (see 4.2.298), Section_interface_relationship (see 4.2.299), Section_relationship (see 4.2.300), Signal (see 4.2.309), Signal_value (see 4.2.313), Specific_item_classification (see 4.2.321), Specification (see 4.2.323), Specification_category (see 4.2.324), Specification_expression (see 4.2.326), Specification_expression (see 4.2.326), Specification_inclusion (see 4.2.327), Technical_system (see 4.2.336), Technical_system_relationship (see 4.2.337), Terminal (see 4.2.338), Work_order (see 4.2.364), or Work_request (see 4.2.365).

See 4.3.1490, 4.3.1491, 4.3.1492, 4.3.1493, 4.3.1494, 4.3.1495, 4.3.1496, 4.3.1497, 4.3.1498, 4.3.1499, 4.3.1500, 4.3.1501, 4.3.1502, 4.3.1503, 4.3.1504, 4.3.1505, 4.3.1506, 4.3.1507, 4.3.1508, 4.3.1509, 4.3.1510, 4.3.1511, 4.3.1512, 4.3.1513, 4.3.1514, 4.3.1515, 4.3.1516, 4.3.1517, 4.3.1518, 4.3.1519, 4.3.1520, 4.3.1521, 4.3.1522, 4.3.1523, 4.3.1524, 4.3.1525, 4.3.1526, 4.3.1527, 4.3.1528, 4.3.1529, 4.3.1530, 4.3.1531, 4.3.1532, 4.3.1533, 4.3.1534, 4.3.1535, 4.3.1536, 4.3.1537, 4.3.1538, 4.3.1539, 4.3.1540, 4.3.1541, 4.3.1542, 4.3.1543, 4.3.1544, 4.3.1545, 4.3.1546, 4.3.1548, 4.3.1549, 4.3.1550, 4.3.1551, 4.3.1552, 4.3.1553, 4.3.1554, 4.3.1555, 4.3.1556, 4.3.1557, 4.3.1558, 4.3.1559, 4.3.1560, 4.3.1561, 4.3.1562, 4.3.1563, 4.3.1564, 4.3.1565, 4.3.1566, 4.3.1567, 4.3.1568, 4.3.1569, 4.3.1570, 4.3.1571, 4.3.1572, 4.3.1573, 4.3.1574, 4.3.1575, 4.3.1576, 4.3.1577, 4.3.1578, 4.3.1579, 4.3.1580, 4.3.1581, 4.3.1582, 4.3.1583, 4.3.1584, 4.3.1585, 4.3.1586, 4.3.1587, 4.3.1588, 4.3.1589, 4.3.1590, 4.3.1591, 4.3.1592, 4.3.1593, 4.3.1594, 4.3.1595, 4.3.1596, 4.3.1597, 4.3.1598, 4.3.1599, and 4.3.1600 for the application assertions.

4.2.212.4 role

The role specifies the scope of the assigned annotation object.

ISO 10303-212:2001(E)

The value of role is one of the following:

- attribute only;
- whole item.

NOTE 2 See 4.2.212.4.1 - 4.2.212.4.2 for the definition of each permissible value for role.

4.2.212.4.1 attribute only

attribute only: The associated annotation applies to the attribute specified through applied_attribute_name only.

4.2.212.4.2 whole item

whole item: The associated annotation applies to the whole item associated through associated_item.

4.2.213 Note_reference

A Note_reference is a type of Cross_reference (see 4.2.64) that is a reference made from one part of a diagram to another part between a note and the item being commented.

The data associated with a Note_reference are the following:

- note_presentation;
- presentation_of_item.

4.2.213.1 note_presentation

The note_presentation specifies the image that depicts the annotation in pictorial form.

See 4.3.1601 for the application assertion.

4.2.213.2 presentation_of_item

The presentation_of_item specifies the pictorial representation.

See 4.3.1602 for the application assertion.

4.2.214 Notification

A Notification is a report of the occurrence of an event.

NOTE A Notification can be caused by a Signal (see 4.2.309). In this case the Notification represents the information transmitted by this particular Signal (see 4.2.309).

EXAMPLE A Notification can be 'emergency switch-off', 'main drive on', 'Fresh-water reservoir empty', etc.

The data associated with a Notification are the following:

- description;
- id;
- language_specification;
- text_of_message;
- trigger;
- version_id.

4.2.214.1 description

The description specifies an alphanumeric string containing human-interpretable text that gives further details about the Notification.

The description need not be specified for a particular Notification.

4.2.214.2 id

The id specifies the identifier of the Notification.

4.2.214.3 language_specification

The language_specification specifies a language spoken by human beings to communicate with each other verbally or in written form. This language is used to phrase the content of the 'text_of_message' attribute.

The language_specification need not be specified for a particular Notification.

See 4.3.1603 for the application assertion.

4.2.214.4 text_of_message

The text_of_message specifies the information conveyed by a Notification. The information shall be either for computer interpretation only, or for human interpretation.

The text_of_message need not be specified for a particular Notification.

ISO 10303-212:2001(E)

4.2.214.5 trigger

The trigger specifies trigger event that initiates the notification.

Each trigger may be one of the following: Process_variable (see 4.2.260), Signal (see 4.2.309), or Signal_value (see 4.2.313).

See 4.3.1604, 4.3.1605, and 4.3.1606 for the application assertions.

4.2.214.6 version_id

The version_id specifies versioning information for the Notification.

The version_id need not be specified for a particular Notification.

4.2.215 Notification_relationship

A Notification_relationship is a relation between two Notification (see 4.2.213) objects.

The data associated with a Notification_relationship are the following:

- description;
- related;
- relating;
- relation_type.

4.2.215.1 description

The description specifies an alphanumeric string containing human-interpretable text that gives further details about the Notification_relationship.

The description need not be specified for a particular Notification_relationship.

4.2.215.2 related

The related specifies the second of the two Notification (see 4.2.213) objects related by the Notification_relationship.

See 4.3.1607 for the application assertion.

4.2.215.3 relating

The relating specifies the first of the two Notification (see 4.2.213) objects related by the Notification_relationship.

See 4.3.1608 for the application assertion.

4.2.215.4 relation_type

The `relation_type` specifies the meaning of the relationship. The value is either user defined or predefined.

The predefined value of `relation_type` is one of the following:

- alternate;
- decomposition;
- derivation;
- substitution;
- translation.

NOTE 1 See 4.2.215.4.1 - 4.2.215.4.5 for the definition of each predefined value for `relation_type`.

4.2.215.4.1 alternate

alternate: The `Notification_relationship` defines a relationship where the related Notification (see 4.2.213) is a possible substitute to the relating Notification (see 4.2.213).

NOTE 2 This concept refers to the possibility to replace the Notification (see 4.2.213). The actual replacement is addressed by 'substitution'.

4.2.215.4.2 decomposition

decomposition: The `Notification_relationship` defines a relationship where the related Notification (see 4.2.213) is one of the components into which the relating Notification (see 4.2.213) is divided.

4.2.215.4.3 derivation

derivation: The `Notification_relationship` defines a deriving relationship where the related Notification (see 4.2.213) is based on the relating Notification (see 4.2.213).

4.2.215.4.4 substitution

substitution: The `Notification_relationship` defines a relationship where the related Notification (see 4.2.213) replaces the relating Notification (see 4.2.213).

4.2.215.4.5 translation

translation: The `Notification_relationship` defines a relationship where the related Notification (see 4.2.213) is a transcription into another language of the relating Notification (see 4.2.213).

4.2.216 Numerical_precision

A `Numerical_precision` is the information about the mathematical precision of the numerical values contained in a graphical product model.

ISO 10303-212:2001(E)

The data associated with a Numerical_precision are the following:

- angular_precision;
- distance_precision.

4.2.216.1 angular_precision

The angular_precision specifies the maximum value for the absolute difference between two angle values when the creating system assumes these two angles to be identical.

4.2.216.2 distance_precision

The distance_precision specifies the maximum value for the absolute difference between two coordinate values when the creating system assumes these two coordinate values to be identical.

NOTE The distance_precision is used to determine the tolerance range for continuous curve, surface connections, or for the determination of a point laying on a curve or surface.

4.2.217 Numerical_value

A Numerical_value is a type of Value_with_unit (see 4.2.360) that is an amount expressed as a multiple of a standardized quantity.

The data associated with a Numerical_value are the following:

- value_component.

4.2.217.1 value_component

The value_component specifies the numerical part of Numerical_value.

4.2.218 Object_designation

An Object_designation is an identifier used to name physical or abstract items.

NOTE The Object_designation allows to preserve the internal structure of the identification. By using the Object_designation_relationship (see 4.2.218) the structure of a reference designation can be expressed. Furthermore the information provided with Object_designation enables a company that extends an existing plant to specify the identification for the added equipment consistently with the methodology used for the already existing items.

Each Object_designation is either a Document_designation (see 4.2.105), an Object_reference_designation (see 4.2.219), a Signal_designation (see 4.2.310), or a Terminal_designation (see 4.2.339).

The data associated with an Object_designation are the following:

- designation_system;
- designator;
- type_of_object_designation.

4.2.218.1 designation_system

The designation_system specifies the methodology used to interpret the designator.

The designation_system need not be specified for a particular Object_designation.

See 4.3.1609 for the application assertion.

4.2.218.2 designator

The designator specifies an alphanumeric string identifying the physical or abstract item the Object_designation is assigned to.

4.2.218.3 type_of_object_designation

The type_of_object_designation specifies the kind of the Object_designation. The value is either user defined or predefined.

The type_of_object_designation need not be specified for a particular Object_designation. The type_of_object_designation need not be specified for a particular Object_designation.

The predefined value of type_of_object_designation is one of the following:

- function designation;
- location designation;
- product designation.

NOTE See 4.2.218.3.1 - 4.2.218.3.3 for the definition of each predefined value for type_of_object_designation.

4.2.218.3.1 function designation

function designation: The Object_designation serves as an identifier or part of an identifier designating the functional aspect of a Function_unit (see 4.2.148) or a Device (see 4.2.88) or a Location (see 4.2.192).

4.2.218.3.2 location designation

location designation: The Object_designation serves as an identifier or as part of an identifier designating the place or position where the designated equipment is located.

4.2.218.3.3 product designation

product designation: The Object_designation serves as an identifier or part of an identifier designating the product aspect of a Function_unit (see 4.2.148), a Device (see 4.2.88), or a Location (see 4.2.192).

4.2.219 Object_designation_relationship

An Object_designation_relationship is an association between Object_designation (see 4.2.217) objects for the formation of hierarchically structured identifiers.

The data associated with an Object_designation_relationship are the following:

- related_object_designation;
- relating_object_designation.

4.2.219.1 related_object_designation

The related_object_designation specifies the Object_designation (see 4.2.217) objects that are the constituents of another Object_designation (see 4.2.217).

See 4.3.1610 for the application assertion.

4.2.219.2 relating_object_designation

The relating_object_designation specifies the Object_designation (see 4.2.217) that is composed of one or more other Object_designation (see 4.2.217) objects.

See 4.3.1611 for the application assertion.

4.2.220 Object_reference_designation

An Object_reference_designation is a type of Object_designation (see 4.2.217) that is the name or identifier of a physical or abstract portion of an electrotechnical system. Within its scope, the Object_reference_designation is unique.

4.2.221 Offered_function_allocation

An Offered_function_allocation is a relation that specifies a service that is accessible within a specific piece of equipment.

The data associated with a `Offered_function_allocation` are the following:

- `description`;
- `offered_functionality`;
- `performing_item`;
- `relation_type`.

4.2.221.1 `description`

The `description` specifies an alphanumeric string containing human-interpretable text that gives further details about the `Offered_function_allocation`.

The `description` need not be specified for a particular `Offered_function_allocation`.

4.2.221.2 `offered_functionality`

The `offered_functionality` specifies an available service.

See 4.3.1614 for the application assertion.

4.2.221.3 `performing_item`

The `performing_item` specifies the equipment that provides the service.

Each `performing_item` may be one of the following: `Design_discipline_item_definition` (see 4.2.86), `Device` (see 4.2.88), `Physical_instance` (see 4.2.243), or `Product_component` (see 4.2.265).

See 4.3.1612, 4.3.1613, 4.3.1615, and 4.3.1616 for the application assertions.

4.2.221.4 `relation_type`

The `relation_type` specifies the meaning of the relationship.

The value of `relation_type` is one of the following:

- `dedicated_function`;
- `offered_function`.

NOTE See 4.2.221.4.1 - 4.2.221.4.2 for the definition of each permissible value for `relation_type`.

4.2.221.4.1 `dedicated_function`

`dedicated_function`: The service is no longer available i.e., the associated `Function_definition` (see 4.2.145) cannot be allocated further.

ISO 10303-212:2001(E)

4.2.221.4.2 offered function

offered function: The service is still available i.e., the associated Function_definition (see 4.2.145) can still be allocated.

4.2.222 Operating_temperature

An Operating_temperature is the allowed ambient temperature of a component under normal operating conditions.

EXAMPLE The Operating_temperature of a notebook computer ranges from 5°C to 35°C, whereas the Storage_temperature (see 4.2.330) ranges from -20°C to 60°C.

The data associated with a Operating_temperature are the following:

— temperature.

4.2.222.1 temperature

The temperature specifies the value of the Operating_temperature.

NOTE Minimum and maximum of Operating_temperature may be specified by assigning a Value_range (see 4.2.359) object.

See 4.3.1617 for the application assertion.

4.2.223 Ordinate_dimension

An Ordinate_dimension is a type of Dimension (see 4.2.93) that is the graphical presentation of a value of linear distance measure where the linear distance is parallel to an axis of the coordinate system of the item being dimensioned. The origin or datum of the linear distance dimension is a point, line, or plane surface corresponding to or coincident with an axis in the plane of the dimension and is perpendicular to the direction of measurement. Only the terminus of the dimension extent is indicated by a projection line parallel to the datum, the dimension value, and associated information.

The data associated with an Ordinate_dimension are the following:

— component.

4.2.223.1 component

The component specifies the projection line that shows the extension of the point, line, or surface.

See 4.3.1618 for the application assertion.

4.2.224 Organization

An Organization is a group of people involved in a particular business process.

The data associated with an Organization are the following:

- delivery_address;
- id;
- name;
- organization_type;
- postal_address;
- visitor_address.

4.2.224.1 delivery_address

The delivery_address specifies the address where to which goods are delivered.

The delivery_address need not be specified for a particular Organization.

See 4.3.1619 for the application assertion.

4.2.224.2 id

The id specifies the identifier of the Organization.

NOTE The assignment of this attribute is usually controlled by a registration authority. The registration authority can be a public organization that assigns identifiers to corporations, or it can be the parent corporation that assigns component identifiers to its components.

EXAMPLE The id can be the code assigned to the Organization for a listing in a stock market, or it can be a department number.

4.2.224.3 name

The name specifies a speaking designation of the Organization.

4.2.224.4 organization_type

The organization_type specifies the type of the Organization. The value is either user defined or predefined.

The predefined value of organization_type is one of the following:

- company;
- department;
- plant.

NOTE See 4.2.224.4.1 - 4.2.224.4.3 for the definition of each predefined value for organization_type.

ISO 10303-212:2001(E)

4.2.224.4.1 company

company: Specifies that the Organization has the legal form of a business or enterprise.

4.2.224.4.2 department

department: Specifies that the Organization is a division or office within a larger organization.

4.2.224.4.3 plant

plant: Specifies that the Organization acts as a manufacturing site.

4.2.224.5 postal_address

The postal_address specifies the address for letter mail.

The postal_address need not be specified for a particular Organization.

See 4.3.1620 for the application assertion.

4.2.224.6 visitor_address

The visitor_address specifies the address where the organization receives visitors.

The visitor_address need not be specified for a particular Organization.

See 4.3.1621 for the application assertion.

4.2.225 Organization_in_contract

An Organization_in_contract is a mechanism to associate the person who is signing a contract and the organization which the person is signing for, to a Contract (see 4.2.63).

The data associated with an Organization_in_contract are the following:

- contract;
- contracted_organization;
- role_of_organization;
- signature.

4.2.225.1 contract

The contract specifies the Contract (see 4.2.63) in which the Organization_in_contract participates.

See 4.3.1622 for the application assertion.

4.2.225.2 contracted_organization

The contracted_organization specifies the organization that participates in the contract.

See 4.3.1624 for the application assertion.

4.2.225.3 role_of_organization

The `role_of_organization` specifies the position of a signing organization with respect to the contract. The value is either user defined or predefined.

The predefined value of `role_of_organization` is one of the following:

— `contractee`;

— `contractor`.

NOTE See 4.2.225.3.1 - 4.2.225.3.2 for the definition of each predefined value for `role_of_organization`.

4.2.225.3.1 contractee

`contractee`: The tasks that are subject of the Contract (see 4.2.63) are assigned to the referenced Organization (see 4.2.223).

4.2.225.3.2 contractor

`contractor`: The referenced Organization (see 4.2.223) assigns the tasks that are subject of the Contract (see 4.2.63).

4.2.225.4 signature

The `signature` specifies the Person (see 4.2.237) or Organization (see 4.2.223) who signed the contract on behalf of the contracted organization and the date of the signature.

See 4.3.1623 for the application assertion.

4.2.226 Organization_relationship

An `Organization_relationship` is an association between two organizations.

ISO 10303-212:2001(E)

EXAMPLE A team belongs to a department which itself belongs to a company. This organizational structure may be built using the Organization_relationship mechanism.

The data associated with an Organization_relationship are the following:

- description;
- related;
- relating;
- relation_type.

4.2.226.1 description

The description specifies an alphanumeric string containing human-interpretable text that gives further details about the Organization_relationship.

The description need not be specified for a particular Organization_relationship.

4.2.226.2 related

The related specifies the other organization in an Organization_relationship.

See 4.3.1625 for the application assertion.

4.2.226.3 relating

The relating specifies the one organization in an Organization_relationship.

See 4.3.1626 for the application assertion.

4.2.226.4 relation_type

The relation_type specifies the meaning of the relationship. The value is either user defined or predefined.

The predefined value of relation_type is one of the following:

- hierarchy;
- legal succession;
- reorganization.

NOTE See 4.2.226.4.1 - 4.2.226.4.3 for the definition of each predefined value for relation_type.

4.2.226.4.1 hierarchy

hierarchy: The related Organization (see 4.2.223) is a sub organization of the relating Organization (see 4.2.223);

4.2.226.4.2 legal succession

legal succession: The related Organization (see 4.2.223) is the legal successor of the relating Organization (see 4.2.223).

NOTE An additional Date_time_assignment (see 4.2.80) may be applied to the Organization_ - relationship in order to specify the time when the succession takes place.

4.2.226.4.3 reorganization

reorganization: The related Organization (see 4.2.223) is the successor of the relating Organization (see 4.2.223) due to an organizational transfer of responsibility.

EXAMPLE The name of a department changes due to reorganization.

4.2.227 Outside_diameter

An Outside_diameter is the outer width of a component with a body of circular cross section.

The data associated with an Outside_diameter are the following:

— value_of_outside_diameter.

4.2.227.1 value_of_outside_diameter

The value_of_outside_diameter specifies the value that indicates the outside diameter.

See 4.3.1627 for the application assertion.

4.2.228 Page_connector

A Page_connector is a cross reference used in schematic diagrams to indicate that a connecting line continues elsewhere on the same sheet or on another sheet of a drawing or in other related documents.

The data associated with a Page_connector are the following:

— page_connector_id;

— part_of;

— type_of.

4.2.228.1 page_connector_id

The page_connector_id specifies an identifier for the Page_connector that is unique within its scope.

4.2.228.2 part_of

The part_of specifies the Connecting_line (see 4.2.58) of which the Page_connector is a constituent.

See 4.3.1628 for the application assertion.

4.2.228.3 type_of

The type_of specifies the kind of the Page_connector.

The value of type_of is one of the following:

- central;
- exclusive;
- neutral.

NOTE See 4.2.228.3.1 - 4.2.228.3.3 for the definition of each permissible value for relation_type.

4.2.228.3.1 central

central: One or more other Page_connector objects of type 'central' that are referred by this Page_connector exist.

4.2.228.3.2 exclusive

exclusive: There is exactly one other Page_connector of type 'exclusive' referred by this particular Page_connector.

4.2.228.3.3 neutral

neutral: The counterpart the Page_connector is referring to is not a part of the product data defined by this part of ISO 10303. One or more counterparts to a Page_connector of type 'neutral' may exist.

4.2.229 Page_connector_presentation

A Page_connector_presentation is a visualization of a Page_connector (see 4.2.227) in a schematic diagram.

The data associated with a Page_connector_presentation are the following:

- of_page_connector;
- type_of.

4.2.229.1 of_page_connector

The of_page_connector specifies the Page_connector (see 4.2.227) object that is depicted by the Page_connector_presentation.

See 4.3.1629 for the application assertion.

4.2.229.2 type_of

The type_of specifies the kind of the Page_connector_presentation.

The value of `type_of` is one of the following:

- `none`;
- `sink`;
- `source`.

NOTE See 4.2.229.2.1 - 4.2.229.2.3 for the definition of each permissible value for `type_of`.

4.2.229.2.1 none

`none`: One or more other `Page_connector_presentation` objects of the type 'none' that are referred by the `Page_connector_presentation` exists.

4.2.229.2.2 sink

`sink`: Exactly one `Page_connector_presentation` of the kind 'source' to which the `Page_connector_presentation` refers exists.

4.2.229.2.3 source

`source`: One or more `Page_connector_presentation` objects of the kind 'sink' the `Page_connector_presentation` refers to exists.

4.2.230 Page_connector_reference

A `Page_connector_reference` is a type of `Cross_reference` (see 4.2.64) that is a reference made from one part of a diagram to another part between `Page_connector` (see 4.2.227) objects being part of the presentation of the same network.

The data associated with a `Page_connector_reference` are the following:

- `part_of`;
- `refers_to`.

4.2.230.1 part_of

The `part_of` specifies the `Page_connector_presentation` (see 4.2.228) to which the `Page_connector_reference` belongs.

See 4.3.1631 for the application assertion.

4.2.230.2 refers_to

The `refers_to` specifies the `Page_connector` (see 4.2.227) or `Page_connector_presentation` (see 4.2.228) object at which the `Page_connector_reference` points.

Each `refers_to` may be one of the following: `Page_connector` (see 4.2.227) or `Page_connector_presentation` (see 4.2.228).

ISO 10303-212:2001(E)

See 4.3.1630 and 4.3.1632 for the application assertions.

4.2.231 Parallel_dimension_pair

A `Parallel_dimension_pair` is a type of `Dimension_sequence_pair` (see 4.2.97) that is the relationship between two dimensions of the same type, wherein their dimension lines are parallel and share a common baseline or datum.

4.2.232 Partial_document_assignment

A `Partial_document_assignment` is a type of `Document_assignment` (see 4.2.102) that identifies a specific portion of the contents of a document or a set of documents and associates it to the product data in which this particular portion is relevant.

The data associated with a `Partial_document_assignment` are the following:

- `document_portion`.

4.2.232.1 document_portion

The `document_portion` specifies the word or group of words that convey the subject or sub contents of the `Document` (see 4.2.101).

EXAMPLE If the assigned document is a service manual of a complete power train, the 'document_portion' attribute specifies that only the information related to electric fuses is relevant.

4.2.233 Path

A `Path` is a track taken to get from a starting-point to a destination. The `Path` may be specified as an ordered collection of `Path_segment` (see 4.2.236) objects.

NOTE A `Path` is understood as a sequence of vertices and edges, where the edges are `Path_segment` (see 4.2.236) objects, and the vertices are `Path_node` (see 4.2.233) objects.

EXAMPLE A `Path` may specify the geometrical course of a cableway.

The data associated with a `Path` are the following:

- `consists_of`;
- `id`;
- `version_id`.

4.2.233.1 consists_of

The `consists_of` specifies the `Path_segment` (see 4.2.236) objects that define the geometrical or course of the `Path`. The associated `Path_segment` (see 4.2.236) objects shall specify a continuous trail.

See 4.3.1633 for the application assertion.

4.2.233.2 id

The `id` specifies the identifier of the `Path`.

4.2.233.3 version_id

The `version_id` specifies versioning information for the `Path`.

The `version_id` need not be specified for a particular `Path`.

4.2.234 Path_node

A `Path_node` is a vertex within a `Path` (see 4.2.232).

NOTE A `Path` (see 4.2.232) is understood as a sequence of vertices and edges, where the vertices are `Path_node` objects.

The data associated with a `Path_node` are the following:

- `defined_in`;
- `id`;
- `position`.

4.2.234.1 defined_in

The `defined_in` specifies the `Location` (see 4.2.192) that provides the coordinate system used to define the position of the `Path_node`.

See 4.3.1635 for the application assertion.

4.2.234.2 id

The `id` specifies the identifier of the `Path_node`.

4.2.234.3 position

The `position` specifies the three-dimensional placement of the `Path_node`.

See 4.3.1634 for the application assertion.

4.2.235 Path_node_relationship

A `Path_node_relationship` is the relation between two `Path_node` (see 4.2.233) objects.

ISO 10303-212:2001(E)

The data associated with an Path_node_relationship are the following:

- description;
- related;
- relating;
- relation_type.

4.2.235.1 description

The description specifies an alphanumeric string containing human-interpretable text that gives further details about the Path_node_relationship.

The description need not be specified for a particular Path_node_relationship.

4.2.235.2 related

The related specifies the second of the two Path_node (see 4.2.233) objects related by the Path_node_relationship.

See 4.3.1636 for the application assertion.

4.2.235.3 relating

The relating specifies the first of the two Path_node (see 4.2.233) objects related by the Path_node_relationship.

See 4.3.1637 for the application assertion.

4.2.235.4 relation_type

The relation_type specifies the meaning of the relationship. The value is either user defined or predefined.

The predefined value of relation_type is one of the following:

- alternate;
- substitution.

NOTE 1 See 4.2.235.4.1 - 4.2.235.4.2 for the definition of each predefined value for relation_type.

4.2.235.4.1 alternate

alternate: The Path_node_relationship defines a relationship where the related Path_node (see 4.2.233) is a possible substitute to the relating Path_node (see 4.2.233).

NOTE 2 This concept refers to the possibility to replace the Path_node (see 4.2.233). The actual replacement is addressed by 'substitution'.

4.2.235.4.2 substitution

substitution: The Path_node_relationship defines a relationship where the related Path_node (see 4.2.233) replaces the relating Path_node (see 4.2.233).

4.2.236 Path_relationship

A Path_relationship is the relation between two Path (see 4.2.232) objects.

The data associated with a Path_relationship are the following:

- description;
- related;
- relating;
- relation_type.

4.2.236.1 description

The description specifies an alphanumeric string containing human-interpretable text that gives further details about the Path_relationship.

The description need not be specified for a particular Path_relationship.

4.2.236.2 related

The related specifies the second of the two Path (see 4.2.232) objects related by the Path_relationship.

See 4.3.1638 for the application assertion.

4.2.236.3 relating

The relating specifies the first of the two Path (see 4.2.232) objects related by the Path_relationship.

See 4.3.1639 for the application assertion.

4.2.236.4 relation_type

The relation_type specifies the meaning of the relationship. The value is either user defined or predefined.

ISO 10303-212:2001(E)

The predefined value of `relation_type` is one of the following:

- `alternate`;
- `derivation`;
- `substitution`.

NOTE 1 See 4.2.236.4.1 - 4.2.236.4.3 for the definition of each predefined value for `relation_type`.

4.2.236.4.1 `alternate`

`alternate`: The `Path_relationship` defines a relationship where the related `Path` (see 4.2.232) is a possible substitute to the relating `Path` (see 4.2.232).

NOTE 2 This concept refers to the possibility to replace the `Path` (see 4.2.232). The actual replacement is addressed by 'substitution'.

4.2.236.4.2 `derivation`

`derivation`: The `Path_relationship` defines a deriving relationship where the related `Path` (see 4.2.232) is based on the relating `Path` (see 4.2.232).

4.2.236.4.3 `substitution`

`substitution`: The `Path_relationship` defines a relationship where the related `Path` (see 4.2.232) replaces the relating `Path` (see 4.2.232).

4.2.237 `Path_segment`

A `Path_segment` is a continuous track between two `Path_node` (see 4.2.233) objects.

NOTE A `Path` (see 4.2.232) is understood as a sequence of vertices and edges, where the edges are `Path_segment` objects.

The data associated with an `Path_segment` are the following:

- `begins_at`;
- `defined_in`;
- `ends_at`;
- `form`;
- `id`.

4.2.237.1 `begins_at`

The `begins_at` specifies the starting point of the `Path_segment`.

See 4.3.1642 for the application assertion.

4.2.237.2 defined_in

The defined_in specifies the Location (see 4.2.192) that provides the coordinate system to define the Path_segment.

See 4.3.1641 for the application assertion.

4.2.237.3 ends_at

The ends_at specifies the end point of the Path_segment.

See 4.3.1643 for the application assertion.

4.2.237.4 form

The form specifies a three-dimensional curve that defines the shape of the Path_segment. This curve shall be defined in the coordinate system specified by the Location (see 4.2.192) associated through defined_in.

See 4.3.1640 for the application assertion.

4.2.237.5 id

The id specifies the identifier of the Path_segment.

4.2.238 Person

A Person is an individual human being who has some relationship to the product data. The Person shall always be identified in the context of one or more organizations.

The data associated with a Person are the following:

- first_name;
- last_name;
- middle_names;
- preferred_business_address;
- prefix_titles;
- suffix_titles.

4.2.238.1 first_name

The first_name specifies the first element in the list of a person's list of forenames.

The first_name need not be specified for a particular Person.

4.2.238.2 last_name

The last_name specifies the person's surname.

The last_name need not be specified for a particular Person.

4.2.238.3 middle_names

The middle_names specifies the other person's forenames, if there are any.

There may be one or more middle_names for a Person. The middle_names need not be specified for a particular Person.

4.2.238.4 preferred_business_address

The preferred_business_address specifies the location of the office of the Person.

The preferred_business_address need not be specified for a particular Person.

See 4.3.1644 for the application assertion.

4.2.238.5 prefix_titles

The prefix_titles specifies the word, or group of words, that specify the person's social or professional standing and appear before his or her name.

There may be one or more prefix_titles for a Person. The prefix_titles need not be specified for a particular Person.

4.2.238.6 suffix_titles

The suffix_titles specifies the word, or group of words, that specify the person's social or professional standing and appear after his or her name.

There may be one or more suffix_titles for a Person. The suffix_titles need not be specified for a particular Person.

4.2.239 Person_in_organization

A Person_in_organization is the specification of a Person (see 4.2.237) in the context of an Organization (see 4.2.223).

The data associated with an `Person_in_organization` are the following:

- `associated_organization`;
- `associated_person`;
- `id`;
- `location`;
- `role`.

4.2.239.1 associated_organization

The `associated_organization` specifies the Organization (see 4.2.223) with which the Person (see 4.2.237) is associated.

See 4.3.1646 for the application assertion.

4.2.239.2 associated_person

The `associated_person` specifies the Person (see 4.2.237).

See 4.3.1647 for the application assertion.

4.2.239.3 id

The `id` specifies an identifier of the person. The identifier shall be unique within the scope of the '`associated_organization`'.

EXAMPLE The `id` may be a staff number or a user id in a computer system.

4.2.239.4 location

The `location` specifies the relevant address of the `Person_in_organization`.

The `location` need not be specified for a particular `Person_in_organization`.

See 4.3.1645 for the application assertion.

4.2.239.5 role

The `role` specifies the relationship between the Person (see 4.2.237) and the Organization (see 4.2.223).

4.2.240 Person_in_organization_relationship

A `Person_in_organization_relationship` is a mechanism which allows to specify an relationship between two persons in an organization.

ISO 10303-212:2001(E)

EXAMPLE The owner of important product data leaves a company and therefore has a successor. This relationship may be built up using the `Person_in_organization_relationship` mechanism.

The data associated with an `Person_in_organization_relationship` are the following:

- description;
- related;
- relating;
- `relation_type`.

4.2.240.1 description

The description specifies an alphanumeric string containing human-interpretable text that gives further details about the `Person_in_organization_relationship`.

The description need not be specified for a particular `Person_in_organization_relationship`.

4.2.240.2 related

The related specifies the second of the two objects related by the `Person_in_organization_relationship`.

See 4.3.1648 for the application assertion.

4.2.240.3 relating

The relating specifies the first of the two objects related by the `Person_in_organization_relationship`.

See 4.3.1649 for the application assertion.

4.2.240.4 relation_type

The `relation_type` specifies the meaning of the relationship. The value is either user defined or predefined.

The predefined value of `relation_type` is one of the following:

- successor.

NOTE See 4.2.240.4.1 for the definition of each predefined value for `relation_type`.

4.2.240.4.1 successor

successor: The related `Person_in_organization` (see 4.2.238) is the successor of the relating `Person_in_organization` (see 4.2.238).

4.2.241 Person_organization_assignment

A `Person_organization_assignment` is a relation that associates an `Organization` (see 4.2.223) or a `Person_in_organization` (see 4.2.238) with an item.

The data associated with a `Person_organization_assignment` are the following:

- `assigned_person_or_organization`;
- `description`;
- `is_applied_to`;
- `role`.

4.2.241.1 assigned_person_or_organization

The `assigned_person_or_organization` specifies the concerned individual or organization.

Each `assigned_person_or_organization` may be one of the following: `Organization` (see 4.2.223) or `Person_in_organization` (see 4.2.238).

See 4.3.1724 and 4.3.1730 for the application assertions.

4.2.241.1 description

The `description` specifies an alphanumeric string containing human-interpretable text that gives further details about the `Person_organization_assignment`.

The `description` need not be specified for a particular `Person_organization_assignment`.

4.2.241.2 is_applied_to

The `is_applied_to` specifies the item with which the `Person_organization_assignment` is associated.

Each `is_applied_to` may be one of the following: `Activity` (see 4.2.1), `Activity_element` (see 4.2.2), `Activity_method_assignment` (see 4.2.4), `Activity_relationship` (see 4.2.5), `Alternate_item_relationship` (see 4.2.11), `Approval_status` (see 4.2.25), `Assembly_component_relationship` (see 4.2.26), `Assembly_substitute_relationship` (see 4.2.28), `Cable_pull_information` (see 4.2.33), `Certification` (see 4.2.38), `Class_category_association` (see 4.2.40), `Class_condition_association` (see 4.2.41), `Class_inclusion_association` (see 4.2.42), `Class_specification_association` (see 4.2.44), `Class_structure_relationship` (see 4.2.45), `Classification_association` (see 4.2.46), `Classification_attribute` (see 4.2.47), `Classification_system` (see 4.2.48), `Complex_product` (see 4.2.51), `Complex_product_relationship` (see 4.2.52), `Composition_relationship` (see 4.2.55), `Configuration` (see 4.2.56), `Connectivity_allocation` (see 4.2.60), `Connectivity_definition` (see 4.2.61), `Connectivity_definition_relationship` (see 4.2.62), `Contract` (see 4.2.63), `Data_element` (see 4.2.70), `Data_element_association` (see 4.2.71), `Data_element_definition` (see 4.2.72), `Data_element_relationship` (see 4.2.74), `Data_element_specification` (see 4.2.75), `Design_discipline_item_definition` (see 4.2.86), `Device` (see 4.2.88), `Device_relationship` (see 4.2.89), `Document` (see 4.2.101), `Document_file` (see 4.2.106), `Document_file_relationship` (see 4.2.107), `Document_representation` (see 4.2.110), `Document_version` (see 4.2.114), `Document_version_relationship` (see 4.2.115), `Drawing` (see 4.2.119), `Drawing_sequence` (see 4.2.121), `Drawing_sheet` (see 4.2.122), `Drawing_sheet_relationship` (see

ISO 10303-212:2001(E)

4.2.124), Free_segment (see 4.2.144), Function_definition (see 4.2.145), Function_definition_relationship (see 4.2.146), Function_interface (see 4.2.147), Function_unit (see 4.2.148), Function_unit_relationship (see 4.2.149), Function_version (see 4.2.150), Function_version_relationship (see 4.2.151), Functional_connectivity_definition (see 4.2.152), Functional_connectivity_definition_relationship (see 4.2.153), Functional_unit_allocation (see 4.2.154), Functionality (see 4.2.155), General_classification (see 4.2.156), Generic_note (see 4.2.159), Interface (see 4.2.170), Interface_port (see 4.2.171), Interface_terminal (see 4.2.174), Item (see 4.2.178), Item_definition_relationship (see 4.2.179), Item_version (see 4.2.182), Item_version_relationship (see 4.2.183), Location (see 4.2.192), Location_relationship (see 4.2.194), Marking (see 4.2.199), Material (see 4.2.201), Node (see 4.2.208), Node_relationship (see 4.2.209), Notification (see 4.2.213), Notification_relationship (see 4.2.214), Offered_function_allocation (see 4.2.220), Organization_relationship (see 4.2.225), Path (see 4.2.232), Path_node (see 4.2.233), Path_node_relationship (see 4.2.234), Path_relationship (see 4.2.235), Person_in_organization (see 4.2.238), Person_in_organization_relationship (see 4.2.239), Physical_assembly_relationship (see 4.2.241), Physical_instance (see 4.2.243), Port (see 4.2.247), Port_allocation (see 4.2.248), Port_association (see 4.2.249), Preferred_item_allocation (see 4.2.258), Preferred_item_terminal_allocation (see 4.2.259), Process_variable (see 4.2.260), Process_variable_relationship (see 4.2.261), Product_class (see 4.2.263), Product_identification (see 4.2.268), Product_structure_relationship (see 4.2.270), Project (see 4.2.271), Requirement (see 4.2.285), Requirement_document_assignment (see 4.2.287), Route (see 4.2.290), Route_relationship (see 4.2.291), Routed_segment (see 4.2.293), Section (see 4.2.296), Section_end (see 4.2.297), Section_interface (see 4.2.298), Section_interface_relationship (see 4.2.299), Section_relationship (see 4.2.300), Security_classification (see 4.2.301), Security_level (see 4.2.302), Signal (see 4.2.309), Signal_relationship (see 4.2.311), Signal_value (see 4.2.313), Specification (see 4.2.323), Specification_category (see 4.2.324), Specification_expression (see 4.2.326), Specification_inclusion (see 4.2.327), Technical_system (see 4.2.336), Technical_system_relationship (see 4.2.337), Terminal (see 4.2.338), Work_order (see 4.2.364), or Work_request (see 4.2.365).

See 4.3.1650, 4.3.1651, 4.3.1652, 4.3.1653, 4.3.1654, 4.3.1655, 4.3.1656, 4.3.1657, 4.3.1658, 4.3.1659, 4.3.1660, 4.3.1661, 4.3.1662, 4.3.1663, 4.3.1664, 4.3.1665, 4.3.1666, 4.3.1667, 4.3.1668, 4.3.1669, 4.3.1670, 4.3.1671, 4.3.1672, 4.3.1673, 4.3.1674, 4.3.1675, 4.3.1676, 4.3.1677, 4.3.1678, 4.3.1679, 4.3.1680, 4.3.1681, 4.3.1682, 4.3.1683, 4.3.1684, 4.3.1685, 4.3.1686, 4.3.1687, 4.3.1688, 4.3.1689, 4.3.1690, 4.3.1691, 4.3.1692, 4.3.1693, 4.3.1694, 4.3.1695, 4.3.1696, 4.3.1697, 4.3.1698, 4.3.1699, 4.3.1700, 4.3.1701, 4.3.1702, 4.3.1703, 4.3.1704, 4.3.1705, 4.3.1706, 4.3.1707, 4.3.1708, 4.3.1709, 4.3.1710, 4.3.1711, 4.3.1712, 4.3.1713, 4.3.1714, 4.3.1715, 4.3.1716, 4.3.1717, 4.3.1718, 4.3.1719, 4.3.1720, 4.3.1721, 4.3.1722, 4.3.1723, 4.3.1725, 4.3.1726, 4.3.1727, 4.3.1728, 4.3.1729, 4.3.1731, 4.3.1732, 4.3.1733, 4.3.1734, 4.3.1735, 4.3.1736, 4.3.1737, 4.3.1738, 4.3.1739, 4.3.1740, 4.3.1741, 4.3.1742, 4.3.1743, 4.3.1744, 4.3.1745, 4.3.1746, 4.3.1747, 4.3.1748, 4.3.1749, 4.3.1750, 4.3.1751, 4.3.1752, 4.3.1753, 4.3.1754, 4.3.1755, 4.3.1756, 4.3.1757, 4.3.1758, 4.3.1759, 4.3.1760, 4.3.1761, 4.3.1762, 4.3.1763, 4.3.1764, 4.3.1765, 4.3.1766, 4.3.1767, 4.3.1768, and 4.3.1769 for the application assertions.

4.2.241.3 role

The role specifies the responsibility of the assigned individual or organization with respect to the item to which it is applied. The value is either user defined or predefined.

The predefined value of role is one of the following:

- author;
- classification officer;
- creator;
- custodian;
- customer;
- design supplier;
- editor;
- id owner;
- inspector;
- local representative;
- location;
- manufacturer;
- operator;
- owner;
- scope;
- supplier;
- wholesaler.

NOTE See 4.2.241.3.1 - 4.2.241.3.17 for the definition of each predefined value for role.

4.2.241.3.1 author

author: The referenced item has been originated by the individual or organization.

4.2.241.3.2 classification officer

classification officer: The assigned person or organization is formally responsible for the classification of the referenced object;.

4.2.241.3.3 creator

creator: The referenced item has been created by the individual or organization.

ISO 10303-212:2001(E)

4.2.241.3.4 custodian

custodian: The assigned individual or organization is responsible for the existence and integrity of the referenced item.

4.2.241.3.5 customer

customer: The assigned individual or organization acts as a purchaser or consumer of the referenced item.

NOTE The customer may be part of the same organization as the supplier.

4.2.241.3.6 design supplier

design supplier: The assigned Person (see 4.2.237) or Organization (see 4.2.223) is the one who delivers the data describing the referenced object.

4.2.241.3.7 editor

editor: The assigned individual or organization is responsible for making changes of the referenced item.

4.2.241.3.8 id owner

id owner: The assigned Person (see 4.2.237) or Organization (see 4.2.223) is responsible for the designation of an identifier.

4.2.241.3.9 inspector

inspector: The task of the assigned individual or organization is to supervise the referenced item and to make reports.

4.2.241.3.10 local representative

local representative: The assigned individual or organization acts as a local contact point for the referenced item.

EXAMPLE The jobsite management of a construction site may act as local representative of its company.

4.2.241.3.11 location

location: The assigned Organization (see 4.2.223) is the place where the referenced object can be found or where it takes place.

4.2.241.3.12 manufacturer

manufacturer: The assigned individual or organization produces the referenced item.

4.2.241.3.13 operator

operator: The assigned individual or organization is running the referenced item.

4.2.241.3.14 owner

owner: The assigned individual or organization owns the referenced item.

4.2.241.3.15 scope

scope: The assigned individual or organization specifies the range of validity for the referenced item.

4.2.241.3.16 supplier

supplier: The assigned individual or organization provides the referenced item.

4.2.241.3.17 wholesaler

wholesaler: The assigned Person (see 4.2.237) or Organization (see 4.2.223) is the one who is in the sales chain between the manufacturer and the supplier.

4.2.242 Physical_assembly_relationship

A `Physical_assembly_relationship` is the mechanism to relate one `Physical_instance` (see 4.2.243) as a component to another `Physical_instance` (see 4.2.243) that plays the role of an assembly.

The data associated with a `Physical_assembly_relationship` are the following:

- `is_realization_of`;
- `physical_assembly`;
- `physical_component`.

4.2.242.1 is_realization_of

The `is_realization_of` specifies the `Device` (see 4.2.88) the of which the physical component is an occurrence.

See 4.3.1770 for the application assertion.

4.2.242.2 physical_assembly

The `physical_assembly` specifies the `Physical_instance` (see 4.2.243) that serves as the assembly in the physical structure.

See 4.3.1771 for the application assertion.

4.2.242.3 physical_component

The `physical_component` specifies the `Physical_instance` (see 4.2.243) that serves as a component in the physical structure.

See 4.3.1772 for the application assertion.

4.2.243 Physical_document

ISO 10303-212:2001(E)

A `Physical_document` is a type of `Document_representation` (see 4.2.110) that is a piece of product data that is archived in non-digital form.

EXAMPLE Paper plots of technical drawings, microfiche, or paper documents, such as calculations or test reports, are examples for a `Physical_document`.

The data associated with a `Physical_document` are the following:

— `component`.

4.2.243.1 component

The `component` is any portion of a `Physical_document`.

See 4.3.1773 for the application assertion.

4.2.244 Physical_instance

A `Physical_instance` is a type of `Product_constituent` (see 4.2.266) that is the denomination of a physically realized item that is identified by a lot id or by a serial number.

The data associated with a `Physical_instance` are the following:

— `description`;

— `inventory_number`;

— `is_realization_of`;

— `lot_id`;

— `serial_number`.

4.2.244.1 description

The `description` specifies an alphanumerical string containing human-interpretable text that gives further details about the `Physical_instance`.

The `description` need not be specified for a particular `Physical_instance`.

4.2.244.2 inventory_number

The `inventory_number` specifies an alphanumerical string to identify an item in the detailed list of articles, such as goods and chattels, found to be in the possession of a person or enterprise.

The `inventory_number` need not be specified for a particular `Physical_instance`.

4.2.244.3 is_realization_of

The `is_realization_of` specifies the item that comprises the information defining the `Physical_instance`.

NOTE This information is only necessary for the 'root' component in a physical assembly. For a component this information is already specified through `Physical_assembly_relationship` (see 4.2.241) which references the defining item through the corresponding `Device` (see 4.2.88).

Each `is_realization_of` may be one of the following: `Design_discipline_item_definition` (see 4.2.86) or `Product_identification` (see 4.2.268).

See 4.3.1774 and 4.3.1775 for the application assertions.

4.2.244.4 `lot_id`

The `lot_id` specifies the identifier of the lot of which the `Physical_instance` is a part.

The `lot_id` need not be specified for a particular `Physical_instance`.

4.2.244.5 `serial_number`

The `serial_number` specifies an alphanumerical string to identify a piece of equipment uniquely within a production series. It is indelibly attached to the equipment.

EXAMPLE In the case of the replacement of a device due to a repair, the new device will have another serial number indicating that a replacement of the device has taken place.

The `serial_number` need not be specified for a particular `Physical_instance`.

4.2.245 `Physical_model`

A `Physical_model` is a type of `Document_representation` (see 4.2.110) that is a model of the layout of a complete system or some portion thereof made from materials such as clay or wood in a specific scale.

EXAMPLE A `Physical_model` is used to give the contractor an impression of the arrangement of switchgears and transformers within a planned power plant.

4.2.246 `Point_2d`

A `Point_2d` is a position in a two-dimensional cartesian coordinate space.

4.2.247 `Point_marker_symbol`

A `Point_marker_symbol` is a type of `Predefined_symbol` (see 4.2.255) that is used to visually present the location of a point in a drawing sheet, drawing view, or another symbol.

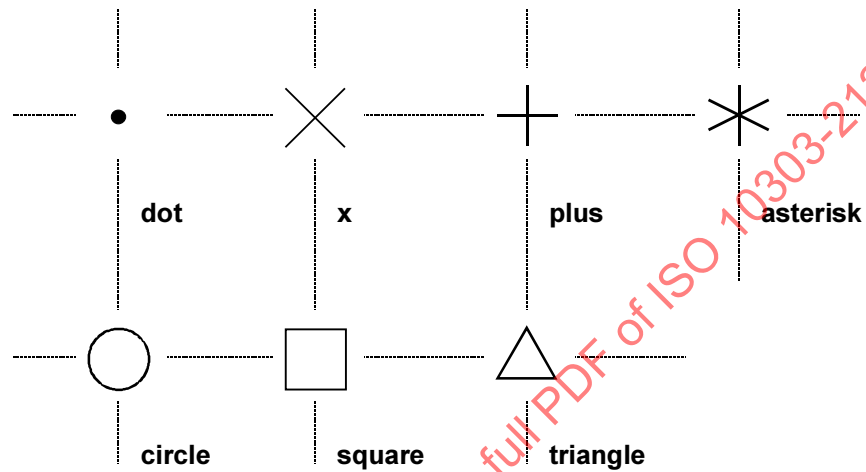

Figure 16 - Predefined point marker symbols

The data associated with a `Point_marker_symbol` are the following:

— `symbol_type`.

4.2.247.1 `symbol_type`

The `symbol_type` specifies an alphanumeric string identifying the `Point_marker_symbol`.

The value of symbol_type is one of the following:

- asterisk;
- circle;
- dot;
- plus;
- square;
- triangle;
- x.

NOTE See 4.2.247.1.1 - 4.2.247.1.7 for the definition of each permissible value for symbol_type.

4.2.247.1.1 asterisk

asterisk: the origin of the symbol is the geometrical centre of the asterisk. The size and graphical representation of the symbol are shown in Figure 16. The reference point lies on the intersection of the dashed lines.

4.2.247.1.2 circle

circle: the origin of the symbol is the centre. The size and graphical representation of the symbol are shown in Figure 16. The reference point lies on the intersection of the dashed lines.

4.2.247.1.3 dot

dot: a dot symbol is depicted as a circle with a fill pattern applied to it. The origin of the dot symbol is the centre of the circle. The size and graphical representation of the symbol are shown in Figure 16. The reference point lies on the intersection of the dashed lines.

4.2.247.1.4 plus

plus: a plus symbol is depicted as two perpendicular line segments. The origin of the symbol is the intersection point of the two line segments. The size and graphical representation of the symbol are shown in Figure 16. The reference point lies on the intersection of the dashed lines.

4.2.247.1.5 square

square: a square symbol is depicted as an even-sided rectangle. The origin of the symbol is the geometrical centre of the square. The size and graphical representation of the symbol are shown in Figure 16. The reference point lies on the intersection of the dashed lines.

4.2.247.1.6 triangle

triangle: the origin of the symbol is the geometrical centre of the triangle. The size and graphical representation of the symbol are shown in Figure 16. The reference point lies on the intersection of the dashed lines.

ISO 10303-212:2001(E)

4.2.247.1.7 x

x: the origin of the symbol is the intersection point of the two line segments. The size and graphical representation of the symbol are shown in Figure 16. The reference point lies on the intersection of the dashed lines.

4.2.248 Port

A Port is the occurrence of an Interface_port (see 4.2.171) used to access a functional module.

The data associated with a Port are the following:

- associated_interface_port;
- description;
- extended_designation;
- id;
- port_of.

4.2.248.1 associated_interface_port

The associated_interface_port specifies the Interface_port (see 4.2.171) that characterizes the access to the functionality of the accessed functional unit.

See 4.3.1776 for the application assertion.

4.2.248.1 description

The description specifies an alphanumeric string containing human-interpretable text that gives further details about the Port.

The description need not be specified for a particular Port.

4.2.248.2 extended_designation

The extended_designation specifies a structured label for the Port.

NOTE The label assigned through extended_designation shall be identical to the label assigned by the 'id' attribute.

The extended_designation need not be specified for a particular Port.

See 4.3.1778 for the application assertion.

4.2.248.3 id

The id specifies the identifier for the Port.

4.2.248.4 port_of

The port_of specifies the Single_function_unit (see 4.2.315) to which the Port belongs.

See 4.3.1777 for the application assertion.

4.2.249 Port_allocation

A Port_allocation is the association of a Port (see 4.2.247) object and its implementation.

NOTE A Port (see 4.2.247) may be implemented through a Function_unit (see 4.2.148).

The data associated with a Port_allocation are the following:

- allocated_port;
- description;
- item_allocation;
- port_implementation.

4.2.249.1 allocated_port

The allocated_port specifies the Port (see 4.2.247) object that is subject of implementation.

See 4.3.1780 for the application assertion.

4.2.249.2 description

The description specifies an alphanumeric string containing human-interpretable text that gives further details about the Port_allocation.

The description need not be specified for a particular Port_allocation.

4.2.249.3 item_allocation

The item_allocation specifies the Functional_unit_allocation (see 4.2.154) object that allocates the Function_unit (see 4.2.148) which owns the ports to its implementation.

The item_allocation need not be specified for a particular Port_allocation.

See 4.3.1779 for the application assertion.

4.2.249.4 port_implementation

The port_implementation specifies the items that implement the Port (see 4.2.247).

See 4.3.1781 for the application assertion.

4.2.250 Port_association

A Port_association is the relation between an Interface_port (see 4.2.171) and a Port (see 4.2.247). In a hierarchical functional decomposition, the Port_association specifies the Port (see 4.2.247) of which the higher level Interface_port (see 4.2.171) is an abstraction.

The data associated with a Port_association are the following:

- associated_interface_port;
- associated_port.

4.2.250.1 associated_interface_port

The associated_interface_port specifies the higher level Interface_port (see 4.2.171).

See 4.3.1782 for the application assertion.

4.2.250.2 associated_port

The associated_port specifies the Port (see 4.2.247) to which the Interface_port (see 4.2.171) is associated.

See 4.3.1783 for the application assertion.

4.2.251 Port_relationship

A Port_relationship is the relation between two Port (see 4.2.247) objects.

The data associated with a Port_relationship are the following:

- description;
- related;
- relating;
- relation_type.

4.2.251.1 description

The description specifies an alphanumeric string containing human-interpretable text that gives further details about the Port_relationship.

The description need not be specified for a particular Port_relationship.

4.2.251.2 related

The related specifies the second of the two Port (see 4.2.247) objects related by the Port_relationship.

See 4.3.1784 for the application assertion.

4.2.251.3 relating

The relating specifies the first of the two Port (see 4.2.247) objects related by the Port_relationship.

See 4.3.1785 for the application assertion.

4.2.251.4 relation_type

The relation_type specifies the meaning of the relationship. The value is either user defined or predefined.

The predefined value of relation_type is one of the following:

- decomposition;
- redundancy.

NOTE See 4.2.251.4.1 and 4.2.251.4.2 for the definition of each predefined value for relation_type.

4.2.251.4.1 decomposition

decomposition: The Port_relationship defines a relationship where the related Port (see 4.2.247) is one of the components into which the relating Port (see 4.2.247) is broken down.

4.2.251.4.2 redundancy

redundancy: The Port_relationship defines a relationship where the related Port (see 4.2.247) is replicated by the relating Port (see 4.2.247).

EXAMPLE To provide for a fail-safe service a Port (see 4.2.247) is replicated. If one Port (see 4.2.247) fails, the other is still in service.

4.2.252 Predefined_colour

A Predefined_colour is a type of Colour (see 4.2.50) that shall be supported by implementations of this part of ISO 10303. A Predefined_colour is defined by an explicit listing of the proportions of blue, green, and red colour according to Table 1.

Table 1 - RGB values for predefined colours

Colour name	Red	Green	Blue
Colour	0.0	0.0	0.0
Red	1.0	0.0	0.0
Green	0.0	1.0	0.0
Blue	0.0	0.0	1.0
Yellow	1.0	1.0	0.0
Magenta	1.0	0.0	1.0
Cyan	0.0	1.0	1.0
White	1.0	1.0	1.0

The data associated with a `Predefined_colour` are the following:

— `colour_id`.

4.2.252.1 `colour_id`

The `colour_id` specifies an alphanumerical string identifying the `Predefined_colour` in accordance to the definitions given above.

4.2.253 `Predefined_connection`

A `Predefined_connection` is a type of `Connection` (see 4.2.59) that shall not be modified.

NOTE Changes of existing connections can occur when the wiring of an electrotechnical system is modified due to design changes or maintenance activities.

EXAMPLE In an existing electrotechnical system, changes occur due to additional customer requirements. These changes affect the connectivity within the system. This particular system contains connections that must not be modified because these connections were carefully designed to avoid electromagnetic interference. To prevent those critical connections from being redesigned, they are identified as `Predefined_connection` objects.

4.2.254 `Predefined_data_element`

A `Predefined_data_element` is a type of `Data_element` (see 4.2.70) that is completely specified in this part of ISO 10303. In a tree of `Data_element` (see 4.2.70) objects formed by using the `Data_element_` - relationship (see 4.2.74), `Predefined_data_element` objects shall occur only as leaves.

The data associated with a `Predefined_data_element` are the following:

— `data`.

4.2.254.1 data

The data specifies the facts that are represented by the `Predefined_data_element`.

Each data may be one of the following: `Body_breadth` (see 4.2.30), `Body_height` (see 4.2.31), `Body_length` (see 4.2.32), `Component_colour` (see 4.2.53), `Cross_section` (see 4.2.65), `Mass` (see 4.2.200), `Material` (see 4.2.201), `Mounting_features` (see 4.2.203), `Operating_temperature` (see 4.2.221), `Outside_diameter` (see 4.2.226), `Rated_current` (see 4.2.278), `Rated_power` (see 4.2.279), `Rated_voltage` (see 4.2.280), or `Storage_temperature` (see 4.2.330).

See 4.3.1786, 4.3.1787, 4.3.1788, 4.3.1789, 4.3.1790, 4.3.1791, 4.3.1792, 4.3.1793, 4.3.1794, 4.3.1795, 4.3.1796, 4.3.1797, 4.3.1798, and 4.3.1799 for the application assertions.

4.2.255 Predefined_line_font

A `Predefined_line_font` is a type of `Line_font` (see 4.2.189) that has a specific physical appearance as defined in this part of ISO 10303. Table 2 gives the length of each line segment and space, in millimetres.

Table 2 - Line segment and space lengths for predefined curve font lists

Curve pattern name	Segment (mm)	Space (mm)	Segment (mm)	Space (mm)	Segment (mm)	Space (mm)	Number of Segments
Curvenuous							0
Dashed	4.0	1.5					2
Chain	7.0	1.0	1.0	1.0			4
Chain double dash	7.0	1.0	1.0	1.0	1.0	1.0	6
Dotted	1.0	1.0					2

The data associated with a `Predefined_line_font` are the following:

— `font_id`.

4.2.255.1 font_id

The `font_id` specifies an alphanumerical string identifying the `Predefined_line_font` in accordance to the definitions given in Table 2.

4.2.256 Predefined_symbol

ISO 10303-212:2001(E)

A `Predefined_symbol` is a type of `Annotation_symbol` (see 4.2.20) that has a specific physical appearance as defined in this part of ISO 10303.

Each `Predefined_symbol` is either a `Dimension_symbol` (see 4.2.98), a `Geometrical_tolerance_symbol` (see 4.2.161), a `Point_marker_symbol` (see 4.2.246), or a `Terminator_symbol` (see 4.2.341).

4.2.257 `Predefined_text_font`

A `Predefined_text_font` is a type of `Text_font` (see 4.2.344) that has an appearance and a character code in accordance to the referenced standard.

The data associated with a `Predefined_text_font` are the following:

— `font_id`.

4.2.257.1 `font_id`

The `font_id` is a string identifying the standard that defines the `Predefined_text_font`.

The value of `font_id` is one of the following:

— `iec 61286`;

— `iso 646`;

— `iso 3098-1`

— `iso 6937`;

— `iso 8859-1`;

— `iso 10646`.

NOTE See 4.2.257.1.1 – 4.2.257.1.5 for the definition of each predefined value for `character_code`.

4.2.257.1.1 `iec 61286`

`iec 61286`: The coded character set used to encode the data is in accordance to IEC 61286.

4.2.257.1.2 `iso 646`

`iso 646`: The coded character set used to encode the data is in accordance to the International Reference Version (IRV) of ISO/IEC 646.

NOTE The IRV of ISO/IEC 646 is identical with the character reservoir commonly known as ASCII.

4.2.257.1.3 `iso 3098-1`

`iso 3098-1`: The coded character set used to encode the data is in accordance to ISO 3098-1.

4.2.257.1.4 `iso 6937`

iso 6937: The coded character set used to encode the data is in accordance to ISO/IEC 6937.

4.2.257.1.5 iso 8859-1

iso 8859-1: The coded character set used to encode the data is in accordance to ISO 8859-1.

4.2.257.1.6 iso 10646

iso 10646: The coded character set used to encode the data is in accordance to ISO/IEC 10646.

4.2.258 Preferred_equipment_assignment

A Preferred_equipment_assignment is the association of the type of equipment to the Signal (see 4.2.309), that is the recommended equipment to process or transmit the Signal (see 4.2.309).

The data associated with a Preferred_equipment_assignment are the following:

- preferred_equipment;
- related_signal;
- valid_context.

4.2.258.1 preferred_equipment

The preferred_equipment specifies the favoured equipment.

Each preferred_equipment may be one of the following: Design_discipline_item_definition (see 4.2.86) or Function_definition (see 4.2.145).

See 4.3.1800 and 4.3.1801 for the application assertions.

4.2.258.2 related_signal

The related_signal specifies the Signal (see 4.2.309) that is to be processed.

See 4.3.1804 for the application assertion.

4.2.258.3 valid_context

The valid_context specifies circumstances under which the recommendation specified through the preferred_equipment attribute is valid.

The valid_context need not be specified for a particular Preferred_equipment_assignment.

Each valid_context may be one of the following: Organization (see 4.2.223) or Product_class (see 4.2.263).

See 4.3.1802 and 4.3.1803 for the application assertions.

4.2.259 Preferred_item_allocation

The Preferred_item_allocation is the association of those items to a Function_unit (see 4.2.148) that are the favoured realization of that Function_unit (see 4.2.148).

EXAMPLE In a mining environment, only explosion-proof equipment may be used.

The data associated with a Preferred_item_allocation are the following:

- description;
- functional_definition;
- preferred_item.

4.2.259.1 description

The description specifies an alphanumeric string containing human-interpretable text that gives further details about the Preferred_item_allocation.

The description need not be specified for a particular Preferred_item_allocation.

4.2.259.2 functional_definition

The functional_definition specifies the Function_unit (see 4.2.148) object.

See 4.3.1807 for the application assertion.

4.2.259.3 preferred_item

The preferred_item specifies the item that represents the favoured implementation of the Function_unit (see 4.2.148) object.

Each preferred_item may be one of the following: Design_discipline_item_definition (see 4.2.86) or Function_definition (see 4.2.145).

See 4.3.1805 and 4.3.1806 for the application assertions.

4.2.260 Preferred_item_terminal_allocation

A Preferred_item_terminal_allocation specifies the favoured implementation of the access nodes of a functional unit.

The data associated with a Preferred_item_terminal_allocation are the following:

- description;
- functional_definition;
- item_allocation;
- preferred_node.

4.2.260.1 description

The description specifies an alphanumeric string containing human-interpretable text that gives further details about the Preferred_item_terminal_allocation.

The description need not be specified for a particular Preferred_item_terminal_allocation.

4.2.260.2 functional_definition

The functional_definition specifies the allocated Port (see 4.2.247) objects.

See 4.3.1810 for the application assertion.

4.2.260.3 item_allocation

The item_allocation specifies the Preferred_item_allocation (see 4.2.258) object that allocates the Function_unit (see 4.2.148), which owns the ports, to its implementation.

See 4.3.1811 for the application assertion.

4.2.260.4 preferred_node

The preferred_node specifies the access nodes that are the preferred implementation of the Port (see 4.2.247) objects specified by the 'functional_definition' attribute.

Each preferred_node may be one of the following: Interface_port (see 4.2.171) or Interface_terminal (see 4.2.174).

See 4.3.1808 and 4.3.1809 for the application assertions.

4.2.261 Process_variable

A Process_variable is a parameter used to control or monitor a process.

ISO 10303-212:2001(E)

NOTE To be processed by an electrotechnical system a `Process_variable` needs to be converted into a `Signal` (see 4.2.309). `Process_variable` objects are considered to be outside of the electrotechnical system. They may serve as an input, output or control of the system.

EXAMPLE `Process_variable` objects are parameters such as rotational speed, temperature, or pressure.

The data associated with a `Process_variable` are the following:

- `associated_value`;
- `description`;
- `id`.

4.2.261.1 `associated_value`

The `associated_value` specifies the quantity that is assigned to the `Process_variable`.

The `associated_value` need not be specified for a particular `Process_variable`.

See 4.3.1812 for the application assertion.

4.2.261.2 `description`

The `description` specifies an alphanumerical string containing human-interpretable text that gives further details about the `Process_variable`.

The `description` need not be specified for a particular `Process_variable`.

4.2.261.3 `id`

The `id` specifies the identifier of the `Process_variable`.

4.2.262 `Process_variable_relationship`

A `Process_variable_relationship` is the relation between two `Process_variable` (see 4.2.260) objects.

The data associated with a `Process_variable_relationship` are the following:

- `description`;
- `related`;
- `relating`;
- `relation_type`.

4.2.262.1 `description`

The `description` specifies an alphanumerical string containing human-interpretable text that gives further details about the `Process_variable_relationship`.

The description need not be specified for a particular Process_variable_relationship.

4.2.262.2 related

The related specifies the second of the two Process_variable (see 4.2.260) objects related by the Process_variable_relationship.

See 4.3.1813 for the application assertion.

4.2.262.3 relating

The relating specifies the first of the two Process_variable (see 4.2.260) objects related by the Process_variable_relationship.

See 4.3.1814 for the application assertion.

4.2.262.4 relation_type

The relation_type specifies the meaning of the relationship. The value is either user defined or predefined.

The predefined value of relation_type is one of the following:

- alternate;
- decomposition;
- substitution.

NOTE 1 See 4.2.262.4.1 - 4.2.262.4.3 for the definition of each predefined value for relation_type.

4.2.262.4.1 alternate

alternate: The Process_variable_relationship defines a relationship where the related Process_variable (see 4.2.260) is a possible substitute to the relating Process_variable (see 4.2.260).

NOTE 2 This concept refers to the possibility to replace the Process_variable (see 4.2.260). The actual replacement is addressed by 'substitution'.

4.2.262.4.2 decomposition

decomposition: The Process_variable_relationship defines a relationship where the related Process_variable (see 4.2.260) is one of the components into which the relating Process_variable (see 4.2.260) is divided.

4.2.262.4.3 substitution

substitution: The Process_variable_relationship defines a relationship where the related Process_variable (see 4.2.260) replaces the relating Process_variable (see 4.2.260).

4.2.263 Process_variable_system_assignment

A Process_variable_system_assignment is an association of a Process_variable (see 4.2.260) with an item, such that the item generates, transforms, transfers, or consumes the Process_variable (see 4.2.260).

The data associated with a Process_variable_system_assignment are the following:

- associated_process_variable;
- associated_system;
- description;
- role.

4.2.263.1 associated_process_variable

The associated_process_variable specifies the Process_variable (see 4.2.260).

See 4.3.1823 for the application assertion.

4.2.263.2 associated_system

The associated_system specifies the item that processes or generates the Process_variable (see 4.2.260).

Each associated_system may be one of the following: Connectivity_definition (see 4.2.61), Design_discipline_item_definition (see 4.2.86), Device (see 4.2.88), Function_definition (see 4.2.145), Function_unit (see 4.2.148), Functional_connectivity_definition (see 4.2.152), Physical_instance (see 4.2.243), Port (see 4.2.247), Technical_system (see 4.2.336), or Terminal (see 4.2.338).

See 4.3.1815, 4.3.1816, 4.3.1817, 4.3.1818, 4.3.1819, 4.3.1820, 4.3.1821, 4.3.1822, 4.3.1824, and 4.3.1825 for the application assertions.

4.2.263.3 description

The description specifies an alphanumeric string containing human-interpretable text that gives further details about the Process_variable_system_assignment.

The description need not be specified for a particular Process_variable_system_assignment.

4.2.263.4 role

The role specifies the relationship between the Process_variable (see 4.2.260) and the associated system. The value is either user defined or predefined.

The predefined value of role is one of the following:

- amplifier;
- monitor;
- source;
- target;
- transmitter.

NOTE See 4.2.263.4.1 - 4.2.263.4.5 for the definition of each predefined value for role.

4.2.263.4.1 amplifier

amplifier: The process variable is boosted within the assigned system.

4.2.263.4.2 monitor

monitor: The process variable is observed within the assigned system.

4.2.263.4.3 source

source: The assigned system acts as a source for the process variable.

EXAMPLE A sensor can be a source for a process variable.

4.2.263.4.4 target

target: The assigned system acts as a target for the process variable.

EXAMPLE A screen that visualizes a message can be a target for a process variable.

4.2.263.4.5 transmitter

transmitter: The process variable is transferred within the assigned system.

4.2.264 Product_class

A Product_class is the identification of a set of similar products to be offered to the market.

ISO 10303-212:2001(E)

NOTE `Product_class` is the application object to which the definitions required for configuration control pertain.

The data associated with a `Product_class` are the following:

- `description`;
- `id`;
- `level_type`;
- `name`;
- `version_id`.

4.2.264.1 description

The description specifies an alphanumeric string containing human-interpretable text that gives further details about the `Product_class`.

The description need not be specified for a particular `Product_class`.

4.2.264.2 id

The id specifies the identifier of the `Product_class`.

4.2.264.3 level_type

The `level_type` specifies the level or category of this `Product_class` in a hierarchical structure of `Product_class` objects.

EXAMPLE A high-level `Product_class` (`level_type` = 'enterprise') may be used to define all `Specification_category` (see 4.2.324) and `Specification` (see 4.2.323) objects for all `Product_class` objects of an enterprise with several brands and companies.

A second-level `Product_class` (`level_type` = 'platform') may be used to group all products that are based on the same technical concept (platform); these products may belong to different brands.

A third level `Product_class` (`level_type` = 'product family') may be used to group all products that have a common base and a fixed set of characteristics (specification categories).

A fourth-level `Product_class` (`level_type` = 'switch type') may represent products that are offered to the market; this level of `Product_class` may be defined by the marketing department. A set of specifications sufficient to produce the car is associated with its `Product_class`. Within this association, a distinction is made between standard characteristics (e.g., housing) and options that have to be chosen (e.g., colour) or that may be chosen by the customer (e.g., number of contacts).

4.2.264.4 name

The name specifies a speaking designation of the `Product_class`.

The name need not be specified for a particular Product_class.

4.2.264.5 version_id

The version_id specifies versioning information for the Product_class.

The version_id need not be specified for a particular Product_class.

4.2.265 Product_class_relationship

A Product_class_relationship is the relation between two Product_class (see 4.2.263) objects.

The data associated with a Product_class_relationship are the following:

- description;
- related;
- relating;
- relation_type.

4.2.265.1 description

The description specifies an alphanumeric string containing human-interpretable text that gives further details about the Product_class_relationship.

The description need not be specified for a particular Product_class_relationship.

4.2.265.2 related

The related specifies the second of the two Product_class (see 4.2.263) objects related by the Product_class_relationship.

See 4.3.1826 for the application assertion.

4.2.265.3 relating

The relating specifies the first of the two Product_class (see 4.2.263) objects related by the Product_class_relationship.

See 4.3.1827 for the application assertion.

4.2.265.4 relation_type

The relation_type specifies the meaning of the relationship. The value is either user defined or predefined.

ISO 10303-212:2001(E)

The predefined value of `relation_type` is one of the following:

- decomposition;
- derivation;
- hierarchy;
- substitution;
- version sequence.

NOTE 1 See 4.2.265.4.1 - 4.2.265.4.5 for the definition of each predefined value for `relation_type`.

4.2.265.4.1 decomposition

decomposition: The `Product_class_relationship` defines a relationship where the related `Product_class` (see 4.2.263) is one of the possible variations of the relating `Product_class` (see 4.2.263).

4.2.265.4.2 derivation

derivation: The `Product_class_relationship` defines a deriving relationship where the related `Product_class` (see 4.2.263) is based on the relating `Product_class` (see 4.2.263).

4.2.265.4.3 hierarchy

hierarchy: The `Product_class_relationship` defines a relationship where the relating `Product_class` (see 4.2.263) is on a higher level in the hierarchy of `Product_class` (see 4.2.263) objects than the related `Product_class` (see 4.2.263).

4.2.265.4.4 substitution

substitution: The `Product_class_relationship` defines a relationship where the related `Product_class` (see 4.2.263) replaces the relating `Product_class` (see 4.2.263).

4.2.265.4.5 version sequence

version sequence: The `Product_class_relationship` defines a relationship where the relating `Product_class` (see 4.2.263) is the preceding version and the related `Product_class` (see 4.2.263) is the following version.

NOTE 2 The relationship does not imply inheritance of any kind between the application objects that are related.

4.2.266 Product_component

A `Product_component` is a type of `Complex_product` (see 4.2.51) that is an element in the product decomposition structure. A `Product_component` may be represented by a set of `Alternative_solution` (see 4.2.12) objects with common functional requirements. The top-level `Product_component` of the decomposition tree shall be associated to a `Product_class` (see 4.2.263) as root entry. The

corresponding decomposition structure is identical for all variations of all products of that Product_class (see 4.2.263).

The data associated with a Product_component are the following:

- description;
- extended_designation;
- instance_required;
- is_influenced_by;
- is_relevant_for;
- name.

4.2.266.1 description

The description specifies an alphanumeric string containing human-interpretable text that gives further details about the Product_component.

The description need not be specified for a particular Product_component.

4.2.266.2 extended_designation

The extended_designation specifies a structured label for the Product_component.

NOTE 1 The label assigned through extended_designation shall be identical to the label assigned by the 'name' attribute.

The extended_designation need not be specified for a particular Product_component.

See 4.3.1830 for the application assertion.

4.2.266.3 instance_required

The instance_required specifies whether or not the existence of a corresponding functional or physical item is required for the various Alternative_solution (see 4.2.12) objects that provide implementations of the Product_component.

NOTE 2 Product_component objects that are not realized by parts may exist. In such cases, no instance of an item is required.

EXAMPLE Holes for wire harnesses are examples of Product_component objects that do not require instances.

4.2.266.4 is_influenced_by

The is_influenced_by specifies the Specification_category (see 4.2.324) objects that impact the design of a solution for the Product_component in the context of the Product_class (see 4.2.263) objects that are referred to by the Class_category_association (see 4.2.40). These Product_class (see

ISO 10303-212:2001(E)

4.2.263) objects shall belong to the set of Product_class (see 4.2.263) objects the Product_component is valid for or shall be subclasses of these Product_class (see 4.2.263) objects.

NOTE 3 All solutions for the Product_component (i.e. the design of these solutions) are influenced by the referenced Specification_category (see 4.2.324).

See 4.3.1829 for the application assertion.

4.2.266.5 is_relevant_for

The is_relevant_for specifies the Application_context (see 4.2.22) in which the Product_component must be considered.

See 4.3.1828 for the application assertion.

4.2.266.6 name

The name specifies a designation of the Product_component.

The name need not be specified for a particular Product_component.

4.2.267 Product_constituent

A Product_constituent is an object that may participate in the functional, logical, or physical breakdown or be an alternate realization of a Complex_product (see 4.2.51).

Each Product_constituent is either a Device (see 4.2.88), a Function_unit (see 4.2.148), a Physical_instance (see 4.2.243), or a Product_component (see 4.2.265).

4.2.268 Product_design

A Product_design is the mechanism to associate an Item_version (see 4.2.182) with its corresponding Product_identification (see 4.2.268), where the specification is met by the design item.

The data associated with a Product_design are the following:

- design;
- product.

4.2.268.1 design

The design specifies the Item_version (see 4.2.182) that meets the requirements.

See 4.3.1831 for the application assertion.

4.2.268.2 product

The product specifies the Product_identification (see 4.2.268) that represents the requirements.

See 4.3.1832 for the application assertion.

4.2.269 Product_identification

A Product_identification identifies an item that is manufacturable or expected as being manufacturable. A Product_identification is defined with respect to the Product_class (see 4.2.263) of which it is a member.

NOTE 1 The type of product that is to be manufactured from the data of the Product_identification is the type of product which is identified through the 'associated_product_class' attribute.

NOTE 2 The intent of Product_identification is the identification of a manufacturable item whereas the intent of Product_class (see 4.2.263) is the gathering of products with similar characteristics.

EXAMPLE A Product_identification associated with a Product_class (see 4.2.263) identifying a family of asynchronous motors is intended to lead to the manufacture of a specific type of asynchronous motor.

NOTE 3 Let 'actual_specification' be the set of instances obtained as the union of the Specification (see 4.2.323) objects related to the 'associated_product_class' through a Class_specification_association (see 4.2.44) or a Class_condition_association (see 4.2.41) with association type 'identification'.

The specification of a Product_identification may be incomplete: there may not be in 'actual_specification' any instance of Specification (see 4.2.323) for some Specification_category (see 4.2.324) declared as mandatory for the 'associated_product_class'. For these Specification_category (see 4.2.324) objects any Specification (see 4.2.323) available in the context of the 'associated product class' is considered as valid for the manufacturing of the product characterized by the considered Product_identification.

The data associated with a Product_identification are the following:

- associated_product_class;
- description;
- id;
- name;
- version_id.

4.2.269.1 associated_product_class

The associated_product_class specifies the Product_class (see 4.2.263) that a product belongs to.

See 4.3.1833 for the application assertion.

4.2.269.2 description

The description specifies an alphanumerical string containing human-interpretable text that gives further details about the Product_identification.

ISO 10303-212:2001(E)

The description need not be specified for a particular Product_identification.

4.2.269.3 id

The id specifies the identifier of the Product_identification.

4.2.269.4 name

The name specifies a speaking designation of the Product_identification.

The name need not be specified for a particular Product_identification.

4.2.269.5 version_id

The version_id specifies the identification of a particular version of a Product_identification.

The version_id need not be specified for a particular Product_identification.

4.2.270 Product_specification

A Product_specification is a type of Product_identification (see 4.2.268) that is the characterization of a manufacturable product for which one or more additional Specification (see 4.2.323) objects enhance the characterization provided for the associated Product_class (see 4.2.263).

NOTE Let 'actual_specification' be the set of instances of Specification (see 4.2.323) obtained as the union of 'defining_specifications' and of the Specification (see 4.2.323) objects related to the 'associated_product_class' through a Class_specification_association (see 4.2.44) or a Class_condition_association (see 4.2.41) with association type 'identification'.

The specification of a Product_specification may be incomplete: there may not be in 'actual_specification' any instance of Specification (see 4.2.323) for some Specification_category (see 4.2.324) declared as mandatory for the 'associated_product_class'. For these Specification_category (see 4.2.324) objects any Specification (see 4.2.323) available in the context of the 'associated_product_class' is considered to be valid for the manufacturing of the product characterized by the considered Product_specification.

EXAMPLE If the colour is not specified for a given family of switches, the equipment resulting from the realization of a Product_specification associated to the Product_class (see 4.2.263) representing the family of switches may be without paint or painted in any available colour.

The data associated with a Product_specification are the following:

— defining_specification.

4.2.270.1 defining_specification

The defining_specification specifies the set of Specification (see 4.2.323) objects necessary to discriminate the Product_specification within its Product_class (see 4.2.263).

See 4.3.1834 for the application assertion.

4.2.271 Product_structure_relationship

A Product_structure_relationship is an association between a Complex_product (see 4.2.51) and a Product_constituent (see 4.2.266), in which the Product_constituent (see 4.2.266) is a functional, logical, or physical component or a realization of the Complex_product (see 4.2.51).

The data associated with an Product_structure_relationship are the following:

- description;
- related;
- relating;
- relation_type.

4.2.271.1 description

The description specifies an alphanumeric string containing human-interpretable text that gives further details about the Product_structure_relationship.

The description need not be specified for a particular Product_structure_relationship.

4.2.271.2 related

The related specifies the Product_constituent (see 4.2.266) that is a functional, logical, or physical component or a realization of the relating Complex_product (see 4.2.51).

NOTE - The semantics of this attribute are defined by the attribute relation_type.

See 4.3.1836 for the application assertion.

4.2.271.3 relating

The relating specifies the Complex_product (see 4.2.51) that is decomposed functionally, logically, or physically into or realized by the related Product_constituent (see 4.2.266).

NOTE - The semantics of this attribute are defined by the attribute relation_type.

See 4.3.1835 for the application assertion.

4.2.271.4 relation_type

The relation_type specifies the meaning of the relationship. The value is either user defined or predefined.

ISO 10303-212:2001(E)

The predefined value of relation_type is one of the following:

- decomposition;
- realization;
- specialization.

NOTE See 4.2.271.4.1 - 4.2.271.4.3 for the definition of each predefined value for relation_type.

4.2.271.4.1 decomposition

decomposition: The related Product_constituent (see 4.2.266) is one of potentially more components of the relating Complex_product (see 4.2.51). This relation type shall only be used for Complex_product (see 4.2.51) and Product_constituent (see 4.2.266) of the same type.

4.2.271.4.2 realization

realization: The related Product_constituent (see 4.2.266) is a means for fulfilling, either partially or fully, the requirements identified with the relating Complex_product (see 4.2.51). This relation type shall be used only when the Complex_product (see 4.2.51) and the Product_constituent (see 4.2.266) are of different types.

4.2.271.4.3 specialization

specialization: The related Product_constituent (see 4.2.266) fulfils the requirements of the relating Complex_product (see 4.2.51) in a more specific way than defined for the relating Complex_product (see 4.2.51). This relation type shall only be used for Product_constituent (see 4.2.266) and Complex_product (see 4.2.51) of the same type.

4.2.272 Project

A Project is a unique process with a time limit, a defined goal, a defined budget, and defined resources.

EXAMPLE For the development of a new product, a project is set up that is responsible for the development decisions as well as for the accounting of the costs.

The data associated with a Project are the following:

- actual_end_date;
- actual_start_date;
- affected_product_class;
- description;
- id;
- name;
- planned_end_date;
- planned_start_date;
- work_program.

4.2.272.1 actual_end_date

The actual_end_date specifies the date when the Project was actually finished.

The actual_end_date need not be specified for a particular Project.

See 4.3.1838 for the application assertion.

4.2.272.2 actual_start_date

The actual_start_date specifies the date when the Project was actually started.

The actual_start_date need not be specified for a particular Project.

See 4.3.1839 for the application assertion.

4.2.272.3 affected_product_class

The affected_product_class specifies the Product_class (see 4.2.263) that is affected by the work carried out within the Project.

See 4.3.1845 for the application assertion.

4.2.272.4 description

The description specifies an alphanumeric string containing human-interpretable text that gives further details about the Project.

The description need not be specified for a particular Project.

4.2.272.5 id

The id specifies the identifier of the Project.

4.2.272.6 name

The name specifies a speaking designation of the Project.

4.2.272.7 planned_end_date

The planned_end_date specifies the date when the Project is or was supposed to be finished.

The planned_end_date need not be specified for a particular Project.

Each planned_end_date may be one of the following: Date_time (see 4.2.79), Duration (see 4.2.126), or Event_reference (see 4.2.130).

See 4.3.1840, 4.3.1842, and 4.3.1843 for the application assertions.

4.2.272.8 planned_start_date

The planned_start_date specifies the date when the Project is or was supposed to be started.

The planned_start_date need not be specified for a particular Project.

Each planned_start_date may be one of the following: Date_time (see 4.2.79) or Event_reference (see 4.2.130).

See 4.3.1841 and 4.3.1844 for the application assertions.

4.2.272.9 work_program

The work program specifies the Activity (see 4.2.1) objects that are carried out within the Project.

See 4.3.1837 for the application assertion.

4.2.273 Project_relationship

A Project_relationship is the relation between two Project (see 4.2.271) objects.

EXAMPLE A team belongs to a department, which itself belongs to a company. This organizational structure can be built using the Organization_relationship (see 4.2.225) mechanism.

The data associated with a Project_relationship are the following:

- description;
- related;
- relating;
- relation_type.

4.2.273.1 description

The description specifies an alphanumeric string containing human-interpretable text that gives further details about the Project_relationship.

The description need not be specified for a particular Project_relationship.

4.2.273.1 related

The related specifies the second of the two Project (see 4.2.271) objects related by a Project_relationship.

NOTE The semantic of this attribute is defined by the relation_type attribute.

See 4.3.1846 for the application assertion.

4.2.273.2 relating

The relating specifies the first of the two Project (see 4.2.271) objects related by a Project_relationship.

NOTE The semantic of this attribute is defined by the relation_type attribute.

See 4.3.1847 for the application assertion.

4.2.273.3 relation_type

The relation_type specifies the meaning of the relationship. The value is either user defined or predefined.

ISO 10303-212:2001(E)

The predefined value of `relation_type` is one of the following:

- decomposition;
- dependency;
- sequence;
- succession.

NOTE See 4.2.273.3.1 - 4.2.273.3.4 for the definition of each predefined value for `relation_type`.

4.2.273.3.1 decomposition

decomposition: The `Project_relationship` defines a relationship where the related `Project` (see 4.2.271) is one of the components into which the relating `Project` (see 4.2.271) is broken down.

4.2.273.3.2 dependency

dependency: The `Project_relationship` defines a relationship where the related `Project` (see 4.2.271) is dependent of the relating `Project` (see 4.2.271).

4.2.273.3.3 sequence

sequence: The `Project_relationship` defines a relationship where the relating `Project` (see 4.2.271) shall be completed before the related `Project` (see 4.2.271) starts.

4.2.273.3.4 succession

succession: The `Project_relationship` defines a relationship where the related `Project` (see 4.2.271) is the successor of the relating `Project` (see 4.2.271).

4.2.274 Projection_line

A `Projection_line` is a type of `Directed_curve` (see 4.2.99) that represents the extension of a point, line, surface, or theoretical point of intersection to a location outside the part outline.

The data associated with a `Projection_line` are the following:

- `projected_element`.

4.2.274.1 projected_element

The `projected_element` specifies the geometric or annotation element that is projected by the projection line.

The `projected_element` need not be specified for a particular `Projection_line`.

See 4.3.1848 for the application assertion.

4.2.275 Promissory_usage

A Promissory_usage is a type of Assembly_component_relationship (see 4.2.26) that is the relation between a constituent of an assembly and the assembly itself. The relationship describes the intention to use the constituent in an assembly. No geometric information is required for the constituent or the assembly that is associated by a Promissory_usage.

EXAMPLE In early design stages the Promissory_usage can be used to create preliminary bills of material for prototyping purpose.

4.2.276 Property_reference

The Property_reference specifies the information that is required to retrieve a Data_element_definition (see 4.2.72) object from a library compliant to ISO 13584-42.

NOTE 1 The library is not necessarily available in computer interpretable form.

The data associated with a Property_reference are the following:

- code;
- name_scope;
- version.

4.2.276.1 code

The code specifies a computer-interpretable identifier for the General_classification (see 4.2.156) object within the repository. The format of this code is defined in ISO 13584-42.

NOTE 2 The type of repository referred within the associated Class_reference (see 4.2.43) may impose further restrictions on the content of this attribute.

4.2.276.1 name_scope

The name_scope specifies the Class_reference (see 4.2.43) in which the property is visible.

See 4.3.1849 for the application assertion.

4.2.276.1 version

The version specifies the variant of the entry in the repository. The format of this version is defined in ISO 13584-42.

NOTE 3 The type of repository referred within the associated Class_reference (see 4.2.43) may impose further restrictions on the content of this attribute.

4.2.277 Quantified_device

A Quantified_device is a type of Device (see 4.2.88) that allows the aggregation of equipment.

ISO 10303-212:2001(E)

EXAMPLE Rivets are not normally addressed individually but as a quantified device.

The data associated with a Quantified_device are the following:

- quantity.

4.2.277.1 quantity

The quantity specifies the value and the unit that stipulate the amount of occurrences.

See 4.3.1850 for the application assertion.

4.2.278 Radius_dimension

A Radius_dimension is a type of Dimension (see 4.2.93) that is the graphical presentation of the value of the radial distance from the centre of a circular element to a point on the element.

The data associated with a Radius_dimension are the following:

- component;
- extent.

4.2.278.1 component

The component specifies the projection lines that shows the extension of the points, lines, or surfaces that bound the measurement.

The component need not be specified for a particular Radius_dimension.

See 4.3.1852 for the application assertion.

4.2.278.2 extent

The extent specifies the dimension line that graphically presents where the dimension value applies.

See 4.3.1851 for the application assertion.

4.2.279 Rated_current

A Rated_current is the magnitude of the electrical current establishing a basis for the design of a piece of equipment.

The data associated with a Rated_current are the following:

- type_of Rated_current;
- value_of Rated_current.

4.2.279.1 type_of Rated_current

The type_of Rated_current specifies the kind of electrical current specified by Rated_current.

The value of `type_of Rated_current` is one of the following:

- ac 3 phase;
- ac 5 phases;
- ac single phase;
- dc.

NOTE See 4.2.279.1.1 - 4.2.279.1.4 for the definition of each permissible value for `type_of Rated_current`.

4.2.279.1.1 ac 3 phase

ac 3 phase: The `Rated_current` is a three-phase alternating current.

4.2.279.1.2 ac 5 phases

ac 5 phases: The `Rated_current` is a five-phase alternating current.

4.2.279.1.3 ac single phase

ac single phase: The `Rated_current` is a single-phase alternating current.

4.2.279.1.4 dc

dc: The `Rated_current` is a direct current.

4.2.279.2 value_of Rated_current

The `value_of Rated_current` specifies the magnitude of the electrical current.

See 4.3.1853 for the application assertion.

4.2.280 Rated_power

A `Rated_power` is the magnitude of the electrical power establishing a basis for the design of a piece of electrotechnical equipment.

The data associated with a `Rated_power` are the following:

- `type_of Rated_power`;
- `value_of Rated_power`.

4.2.280.1 type_of Rated_power

The `type_of Rated_power` specifies the kind of electrical power specified by `Rated_power`.

ISO 10303-212:2001(E)

The value of `type_of Rated_power` is one of the following:

- `apparent power`;
- `reactive power`;
- `true power`.

NOTE See 4.2.280.1.1 - 4.2.280.1.3 for the definition of each permissible value for `type_of Rated_power`.

4.2.280.1.1 `apparent power`

`apparent power`: The `Rated_power` is the electrical power that is the product of the r.m.s values of voltage and current.

4.2.280.1.2 `reactive power`

`reactive power`: The `Rated_power` is the imaginary part of the complex power.

4.2.280.1.3 `true power`

`true power`: The `Rated_power` is the mean value, taken over one period, of the instantaneous power.

4.2.280.2 `value_of Rated_power`

The `value_of Rated_power` specifies the magnitude of the electrical power.

See 4.3.1854 for the application assertion.

4.2.281 `Rated_voltage`

A `Rated_voltage` is the magnitude of the electrical voltage establishing a basis for the design of an electrical device.

The data associated with a `Rated_voltage` are the following:

- `type_of Rated_voltage`;
- `value_of Rated_voltage`.

4.2.281.1 `type_of Rated_voltage`

The `type_of Rated_voltage` specifies the kind of electrical voltage specified by `Rated_voltage`.

The value of `type_of Rated_voltage` is one of the following:

- ac 3 phase;
- ac 5 phase;
- ac single phase;
- dc.

NOTE See 4.2.281.1.1 - 4.2.281.1.5 for the definition of each permissible value for `type_of Rated_voltage`.

4.2.281.1.1 ac 3 phase

ac 3 phase: The `Rated_voltage` is a three-phase alternating voltage.

4.2.281.1.2 ac 5 phase

ac 5 phase: The `Rated_voltage` is a five-phase alternating voltage.

4.2.281.1.3 ac single phase

ac single phase: The `Rated_voltage` is a single-phase alternating voltage.

4.2.281.1.4 dc

dc: The `Rated_voltage` is a direct voltage.

4.2.281.2 value_of Rated_voltage

The `value_of Rated_voltage` specifies the magnitude of the electrical voltage.

See 4.3.1855 for the application assertion.

4.2.282 Rectangular_area

A `Rectangular_area` is a plane area with four straight sides and four right angles, especially one with unequal adjacent sides.

The data associated with a `Rectangular_area` are the following:

- height;
- position;
- width.

4.2.282.1 height

The height specifies the tallness of the area.

ISO 10303-212:2001(E)

4.2.282.2 position

The position specifies the placement of the Rectangular_area.

4.2.282.3 width

The width specifies the broadness of the area.

4.2.283 Rectangular_size

A Rectangular_size is the extent of a rectangular area.

The data associated with a Rectangular_size are the following:

- density;
- height;
- width.

4.2.283.1 density

The density specifies the resolution of the object if it is a raster picture.

The density need not be specified for a particular Rectangular_size.

4.2.283.2 height

The height specifies the size of the object in vertical direction.

4.2.283.3 width

The width specifies the size of the object in horizontal direction.

4.2.284 Reference_grid

A Reference_grid is rectangular pattern of lines that provides a grid reference system in accordance with IEC 61082-1. The grid reference system allows one to identify a location on a diagram.

The data associated with a Reference_grid are the following:

- column_id;
- grid_origin;
- row_id.

4.2.284.1 column_id

The column_id specifies the identifier for each column of the reference grid. The identifiers are contained in a list representing the order of columns from left to right of the sheet.

There shall be one or more `column_id` for a `Reference_grid`.

4.2.284.2 `grid_origin`

The `grid_origin` specifies a fixed point from which coordinates representing the `Reference_grid` are measured.

4.2.284.3 `row_id`

The `row_id` specifies the identifier for each row of the reference grid. The identifiers are contained in a list representing the order of rows from bottom to the top of the sheet.

There shall be one or more `row_id` for a `Reference_grid`.

4.2.285 `Reference_grid_layout`

A `Reference_grid_layout` is a type of `User_defined_symbol_definition` (see 4.2.355) that depicts the arrangement and design of annotation elements that visualize the `Reference_grid` (see 4.2.283) on a diagram.

The data associated with a `Reference_grid_layout` are the following:

- `assigned_reference_grid`.

4.2.285.1 `assigned_reference_grid`

The `assigned_reference_grid` specifies the `Reference_grid` (see 4.2.283) object of which the `reference_grid_layout` is the pictorial representation.

See 4.3.1856 for the application assertion.

4.2.286 `Requirement`

A `Requirement` is human-interpretable product data that describes constraints that the electrotechnical system or some elements of the system may satisfy.

NOTE By making use of `Requirement` objects the design rationale of a system as a whole or of portions thereof can be laid down.

ISO 10303-212:2001(E)

EXAMPLE An error handling system shall provide for a buffer capable to handle 2000 error messages per second for a period of 48 hours.

The data associated with a Requirement are the following:

- description;
- id;
- name;
- version_id.

4.2.286.1 description

The description specifies an alphanumeric string containing human-interpretable text that gives further details about the Requirement.

The description need not be specified for a particular Requirement.

4.2.286.2 id

The id specifies the identifier of the Requirement.

4.2.286.3 name

The name specifies a speaking designation of the Requirement.

The name need not be specified for a particular Requirement.

4.2.286.4 version_id

The version_id specifies versioning information for the Requirement.

The version_id need not be specified for a particular Requirement.

4.2.287 Requirement_assignment

A Requirement_assignment is a relation that associates a Requirement (see 4.2.285) with an physical or abstract item.

The data associated with a Requirement_assignment are the following:

- associated_requirement;
- constrained_element;
- description;
- relation_type.

4.2.287.1 associated_requirement

The associated_requirement specifies the Requirement (see 4.2.285).

See 4.3.1902 for the application assertion.

4.2.287.2 constrained_element

The constrained_element specifies the element to which the Requirement (see 4.2.285) applies.

Each constrained_element may be one of the following: Assembly_component_relationship (see 4.2.26), Complex_product (see 4.2.51), Complex_product_relationship (see 4.2.52), Composition_relationship (see 4.2.55), Connectivity_definition (see 4.2.61), Connectivity_definition_relationship (see 4.2.62), Data_element (see 4.2.70), Design_discipline_item_definition (see 4.2.86), Device (see 4.2.88), Device_relationship (see 4.2.89), Document (see 4.2.101), Document_version (see 4.2.114), Drawing_sheet (see 4.2.122), Drawing_view (see 4.2.125), Function_definition (see 4.2.145), Function_definition_relationship (see 4.2.146), Function_interface (see 4.2.147), Function_unit (see 4.2.148), Function_unit_relationship (see 4.2.149), Function_version (see 4.2.150), Functional_connectivity_definition (see 4.2.152), Functional_connectivity_definition_relationship (see 4.2.153), Functionality (see 4.2.155), Generic_note (see 4.2.159), Interface (see 4.2.170), Interface_port (see 4.2.171), Interface_terminal (see 4.2.174), Item (see 4.2.178), Item_definition_relationship (see 4.2.179), Item_version (see 4.2.182), Location (see 4.2.192), Location_relationship (see 4.2.194), Marking (see 4.2.199), Node (see 4.2.208), Node_relationship (see 4.2.209), Notification (see 4.2.213), Path (see 4.2.232), Path_node (see 4.2.233), Physical_assembly_relationship (see 4.2.241), Physical_instance (see 4.2.243), Port (see 4.2.247), Process_variable (see 4.2.260), Product_class (see 4.2.263), Product_specification (see 4.2.269), Product_structure_relationship (see 4.2.270), Route (see 4.2.290), Route_relationship (see 4.2.291), Section (see 4.2.296), Section_end (see 4.2.297), Section_interface (see 4.2.298), Section_interface_relationship (see 4.2.299), Section_relationship (see 4.2.300), Signal (see 4.2.309), Signal_value (see 4.2.313), Technical_system (see 4.2.336), Technical_system_relationship (see 4.2.337), or Terminal (see 4.2.338).

See 4.3.1857, 4.3.1858, 4.3.1859, 4.3.1860, 4.3.1861, 4.3.1862, 4.3.1863, 4.3.1864, 4.3.1865, 4.3.1866, 4.3.1867, 4.3.1868, 4.3.1869, 4.3.1870, 4.3.1871, 4.3.1872, 4.3.1873, 4.3.1874, 4.3.1875, 4.3.1876, 4.3.1877, 4.3.1878, 4.3.1879, 4.3.1880, 4.3.1881, 4.3.1882, 4.3.1883, 4.3.1884, 4.3.1885, 4.3.1886, 4.3.1887, 4.3.1888, 4.3.1889, 4.3.1890, 4.3.1891, 4.3.1892, 4.3.1893, 4.3.1894, 4.3.1895, 4.3.1896, 4.3.1897, 4.3.1898, 4.3.1899, 4.3.1900, 4.3.1901, 4.3.1903, 4.3.1904, 4.3.1905, 4.3.1906, 4.3.1907, 4.3.1908, 4.3.1909, 4.3.1910, 4.3.1911, 4.3.1912, 4.3.1913, and 4.3.1914 for the application assertions.

4.2.287.3 description

The description specifies an alphanumeric string containing human-interpretable text that gives further details about the Requirement_assignment.

The description need not be specified for a particular Requirement_assignment.

4.2.287.4 relation_type

The relation_type specifies the meaning of the relationship. The value is either user defined or predefined.

ISO 10303-212:2001(E)

The predefined value of `relation_type` is one of the following:

- compelled element;
- solution.

NOTE See 4.2.287.4.1 - 4.2.287.4.2 for the definition of each predefined value for `relation_type`.

4.2.287.4.1 compelled element

compelled element: The `Requirement_assignment` defines a relationship where the associated Requirement (see 4.2.285) levies a constraint against the associated item.

4.2.287.4.2 solution

solution: The `Requirement_assignment` defines a relationship where the `constrained_element` serves as a means to solve the associated Requirement (see 4.2.285).

4.2.288 Requirement_document_assignment

A `Requirement_document_assignment` is a relation that associates a Requirement (see 4.2.285) with a document.

The data associated with a `Requirement_document_assignment` are the following:

- description;
- documentation;
- `documented_requirement`;
- `role_of_document`.

4.2.288.1 description

The description specifies an alphanumeric string containing human-interpretable text that gives further details about the `Requirement_document_assignment`.

The description need not be specified for a particular `Requirement_document_assignment`.

4.2.288.2 documentation

The documentation specifies the record that deals with the Requirement (see 4.2.285).

Each documentation may be one of the following: `Document` (see 4.2.101), `Document_file` (see 4.2.106), `Document_representation` (see 4.2.110), `Document_version` (see 4.2.114), or `Drawing` (see 4.2.119).

See 4.3.1915, 4.3.1916, 4.3.1917, 4.3.1918, and 4.3.1919 for the application assertions.

4.2.288.3 documented_requirement

The `documented_requirement` specifies the Requirement (see 4.2.285) object the document deals with.

See 4.3.1920 for the application assertion.

4.2.288.4 role_of_document

The `role_of_document` specifies the function of the document in respect of the Requirement (see 4.2.285). The value is either user defined or predefined.

The `role_of_document` need not be specified for a particular `Requirement_document_assignment`. The `role_of_document` need not be specified for a particular `Requirement_document_assignment`.

The predefined value of `role_of_document` is one of the following:

- additional information;
- specification;
- verification.

NOTE See 4.2.288.4.1 - 4.2.288.4.3 for the definition of each predefined value for `role_of_document`.

4.2.288.4.1 additional information

`additional information`: The document provides further information on the Requirement (see 4.2.285).

4.2.288.4.2 specification

`specification`: The document raises the Requirement (see 4.2.285).

4.2.288.4.3 verification

`verification`: The document contains information that proves the fulfilment of the Requirement (see 4.2.285).

4.2.289 Requirement_relationship

A `Requirement_relationship` is the relation between two Requirement (see 4.2.285) objects.

ISO 10303-212:2001(E)

The data associated with an Requirement_relationship are the following:

- description;
- related;
- relating;
- relation_type.

4.2.289.1 description

The description specifies an alphanumeric string containing human-interpretable text that gives further details about the Requirement_relationship.

The description need not be specified for a particular Requirement_relationship.

4.2.289.2 related

The related specifies the second of the two Requirement (see 4.2.285) objects related by the Requirement_relationship.

See 4.3.1921 for the application assertion.

4.2.289.3 relating

The relating specifies the first of the two Requirement (see 4.2.285) objects related by the Requirement_relationship.

See 4.3.1922 for the application assertion.

4.2.289.4 relation_type

The relation_type specifies the meaning of the relationship. The value is either user defined or predefined.

The predefined value of relation_type is one of the following:

- alternate;
- decomposition;
- derivation;
- substitution;
- version hierarchy;
- version sequence.

NOTE 1 See 4.2.289.4.1 - 4.2.289.4.6 for the definition of each predefined value for relation_type.

4.2.289.4.1 alternate

alternate: The Requirement_relationship defines a relationship where the related Requirement (see 4.2.285) is a possible substitute to the relating Requirement (see 4.2.285).

NOTE 2 This concept refers to the possibility to replace the Requirement (see 4.2.285). The actual replacement is addressed by 'substitution'.

4.2.289.4.2 decomposition

decomposition: The Requirement_relationship defines a relationship where the related Requirement (see 4.2.285) is one of the components into which the relating Requirement (see 4.2.285) is divided.

4.2.289.4.3 derivation

derivation: The Requirement_relationship defines a deriving relationship where the related Requirement (see 4.2.285) is based on the relating Requirement (see 4.2.285).

4.2.289.4.4 substitution

substitution: The Requirement_relationship defines a relationship where the related Requirement (see 4.2.285) replaces the relating Requirement (see 4.2.285).

4.2.289.4.5 version hierarchy

version hierarchy: The Requirement_relationship defines a hierarchical relationship where the related Requirement (see 4.2.285) is a subversion of the relating Requirement (see 4.2.285).

EXAMPLE Revision 1.1 and 1.2 of a requirement.

4.2.289.4.6 version sequence

version sequence: The Requirement_relationship defines a succession of versions where the relating Requirement (see 4.2.285) is the preceding version and the related Requirement (see 4.2.285) is the following version. For a Requirement (see 4.2.285), there shall be, at the most, one Requirement_relationship of this relation type as relating and, at most, one Requirement_relationship of this relation type as related.

4.2.290 Retention_period

A Retention_period is the definition of the period of time that product data needs to be maintained due to organizational policy or legal requirements.

ISO 10303-212:2001(E)

The data associated with a `Retention_period` are the following:

- `earliest_end_definition`;
- `is_applied_to`;
- `latest_end_definition`;
- `retention_purpose`;
- `start_definition`.

4.2.290.1 `earliest_end_definition`

The `earliest_end_definition` specifies the earliest point in time from which on all items, the `Retention_period` is applied to, may be deleted. In this context deletion applies to all subordinate items that are not referenced by other items.

Each `earliest_end_definition` may be one of the following: `Date_time` (see 4.2.79), `Duration` (see 4.2.126), or `Event_reference` (see 4.2.130).

See 4.3.1954, 4.3.1970, and 4.3.1972 for the application assertions.

4.2.290.2 `is_applied_to`

The `is_applied_to` specifies the items that are controlled by the `Retention_period`.

NOTE The master document is the one for which earliest end definition and latest end definition are the same.

Each `is_applied_to` may be one of the following: `Activity` (see 4.2.1), `Activity_element` (see 4.2.2), `Activity_method_assignment` (see 4.2.4), `Activity_relationship` (see 4.2.5), `Alternate_item_relationship` (see 4.2.11), `Approval_status` (see 4.2.25), `Assembly_component_relationship` (see 4.2.26), `Assembly_substitute_relationship` (see 4.2.28), `Cable_pull_information` (see 4.2.33), `Certification` (see 4.2.38), `Class_category_association` (see 4.2.40), `Class_condition_association` (see 4.2.41), `Class_inclusion_association` (see 4.2.42), `Class_specification_association` (see 4.2.44), `Class_structure_relationship` (see 4.2.45), `Classification_association` (see 4.2.46), `Classification_attribute` (see 4.2.47), `Classification_system` (see 4.2.48), `Complex_product` (see 4.2.51), `Complex_product_relationship` (see 4.2.52), `Composition_relationship` (see 4.2.55), `Configuration` (see 4.2.56), `Connectivity_allocation` (see 4.2.60), `Connectivity_definition` (see 4.2.61), `Connectivity_definition_relationship` (see 4.2.62), `Contract` (see 4.2.63), `Data_element` (see 4.2.70), `Data_element_association` (see 4.2.71), `Data_element_definition` (see 4.2.72), `Data_element_relationship` (see 4.2.74), `Data_element_specification` (see 4.2.75), `Design_discipline_item_definition` (see 4.2.86), `Device` (see 4.2.88), `Device_relationship` (see 4.2.89), `Document` (see 4.2.101), `Document_file` (see 4.2.106), `Document_file_relationship` (see 4.2.107), `Document_representation` (see 4.2.110), `Document_version` (see 4.2.114), `Document_version_relationship` (see 4.2.115), `Drawing` (see 4.2.119), `Drawing_sequence` (see 4.2.121), `Drawing_sheet` (see 4.2.122), `Drawing_sheet_relationship` (see 4.2.124), `Free_segment` (see 4.2.144), `Function_definition` (see 4.2.145), `Function_definition_relationship` (see 4.2.146), `Function_interface` (see 4.2.147), `Function_unit` (see 4.2.148), `Function_unit_relationship` (see 4.2.149), `Function_version` (see 4.2.150), `Function_version_relationship` (see 4.2.151), `Functional_connectivity_definition` (see 4.2.152), `Functional_connectivity_definition_relationship` (see 4.2.153), `Functional_unit_allocation` (see 4.2.154), `Functionality` (see 4.2.155),

General_classification (see 4.2.156), Generic_note (see 4.2.159), Interface (see 4.2.170), Interface_port (see 4.2.171), Interface_terminal (see 4.2.174), Item (see 4.2.178), Item_definition_relationship (see 4.2.179), Item_version (see 4.2.182), Item_version_relationship (see 4.2.183), Location (see 4.2.192), Location_relationship (see 4.2.194), Marking (see 4.2.199), Material (see 4.2.201), Node (see 4.2.208), Node_relationship (see 4.2.209), Notification (see 4.2.213), Notification_relationship (see 4.2.214), Offered_function_allocation (see 4.2.220), Organization_relationship (see 4.2.225), Path (see 4.2.232), Path_node (see 4.2.233), Path_node_relationship (see 4.2.234), Path_relationship (see 4.2.235), Person_in_organization (see 4.2.238), Person_in_organization_relationship (see 4.2.239), Physical_assembly_relationship (see 4.2.241), Physical_instance (see 4.2.243), Port (see 4.2.247), Port_allocation (see 4.2.248), Port_association (see 4.2.249), Preferred_item_allocation (see 4.2.258), Preferred_item_terminal_allocation (see 4.2.259), Process_variable (see 4.2.260), Process_variable_relationship (see 4.2.261), Product_class (see 4.2.263), Product_identification (see 4.2.268), Product_structure_relationship (see 4.2.270), Project (see 4.2.271), Requirement (see 4.2.285), Requirement_document_assignment (see 4.2.287), Route (see 4.2.290), Route_relationship (see 4.2.291), Routed_segment (see 4.2.293), Section (see 4.2.296), Section_end (see 4.2.297), Section_interface (see 4.2.298), Section_interface_relationship (see 4.2.299), Section_relationship (see 4.2.300), Security_classification (see 4.2.301), Security_level (see 4.2.302), Signal (see 4.2.309), Signal_relationship (see 4.2.311), Signal_value (see 4.2.313), Specification (see 4.2.323), Specification_category (see 4.2.324), Specification_expression (see 4.2.326), Specification_inclusion (see 4.2.327), Technical_system (see 4.2.336), Technical_system_relationship (see 4.2.337), Terminal (see 4.2.338), Work_order (see 4.2.364), or Work_request (see 4.2.365).

See 4.3.1923, 4.3.1924, 4.3.1925, 4.3.1926, 4.3.1927, 4.3.1928, 4.3.1929, 4.3.1930, 4.3.1931, 4.3.1932, 4.3.1933, 4.3.1934, 4.3.1935, 4.3.1936, 4.3.1937, 4.3.1938, 4.3.1939, 4.3.1940, 4.3.1941, 4.3.1942, 4.3.1943, 4.3.1944, 4.3.1945, 4.3.1946, 4.3.1947, 4.3.1948, 4.3.1949, 4.3.1950, 4.3.1951, 4.3.1952, 4.3.1953, 4.3.1957, 4.3.1958, 4.3.1959, 4.3.1960, 4.3.1961, 4.3.1962, 4.3.1963, 4.3.1964, 4.3.1965, 4.3.1966, 4.3.1967, 4.3.1968, 4.3.1969, 4.3.1975, 4.3.1976, 4.3.1977, 4.3.1978, 4.3.1979, 4.3.1980, 4.3.1981, 4.3.1982, 4.3.1983, 4.3.1984, 4.3.1985, 4.3.1986, 4.3.1987, 4.3.1988, 4.3.1989, 4.3.1990, 4.3.1991, 4.3.1992, 4.3.1993, 4.3.1994, 4.3.1995, 4.3.1996, 4.3.1997, 4.3.1998, 4.3.1999, 4.3.2000, 4.3.2001, 4.3.2002, 4.3.2003, 4.3.2004, 4.3.2005, 4.3.2006, 4.3.2007, 4.3.2008, 4.3.2009, 4.3.2010, 4.3.2011, 4.3.2012, 4.3.2013, 4.3.2014, 4.3.2015, 4.3.2016, 4.3.2017, 4.3.2018, 4.3.2019, 4.3.2020, 4.3.2021, 4.3.2022, 4.3.2023, 4.3.2024, 4.3.2025, 4.3.2026, 4.3.2027, 4.3.2028, 4.3.2029, 4.3.2030, 4.3.2031, 4.3.2032, 4.3.2033, 4.3.2034, 4.3.2035, 4.3.2036, 4.3.2037, 4.3.2038, 4.3.2039, 4.3.2040, 4.3.2041, 4.3.2042, 4.3.2043, 4.3.2044, 4.3.2045, 4.3.2046, 4.3.2047, and 4.3.2048 for the application assertions

4.2.290.3 latest_end_definition

The latest_end_definition specifies the latest point in time at which all items, to which the Retention_period applies, are deleted. In this context deletion applies to all subordinate items that are not used by other items.

Each latest_end_definition may be one of the following: Date_time (see 4.2.79), Duration (see 4.2.126), or Event_reference (see 4.2.130).

See 4.3.1955, 4.3.1971, and 4.3.1973 for the application assertions.

4.2.290.4 retention_purpose

The retention_purpose specifies the rationale behind the Retention_period.

ISO 10303-212:2001(E)

The retention_purpose need not be specified for a particular Retention_period.

4.2.290.5 start_definition

The start_definition specifies the point in time at which the Retention_period starts.

Each start_definition may be one of the following: Date_time (see 4.2.79) or Event_reference (see 4.2.130).

See 4.3.1956 and 4.3.1974 for the application assertions.

4.2.291 Route

A Route is a named course taken to get from a starting point to a destination.

NOTE 1 A Route is understood as a sequence of vertices and edges, where the edges are Section (see 4.2.296) objects and the vertices are Node (see 4.2.208) objects. Routed_object (see 4.2.292) objects allow for the specification of the items that make use of the Route.

EXAMPLE 1 A cable rack provides routes for cables. Some its routes are occupied, i.e. a cable is laid on that route, others may remain empty for future use. To specify that a cable is routed partially or as a whole it is assigned to Routed_object (see 4.2.292) objects which in turn are associated to the Route.

NOTE 2 A Route can be used to specify a path travelled by a person for delivering, selling, or collecting goods or services.

EXAMPLE 2 A path travelled by a person throughout the commissioning of a power plant, e.g. for inspection purposes.

The data associated with a Route are the following:

- course;
- description;
- encountered_object;
- id;
- version_id.

4.2.291.1 course

The course specifies the direction taken.

Each course may be one of the following: Node (see 4.2.208), Section (see 4.2.296), or Section_interface (see 4.2.298).

See 4.3.2054, 4.3.2057, and 4.3.2058 for the application assertions.

4.2.291.2 description

The description specifies an alphanumeric string containing human-interpretable text that gives further details about the Route.

The description need not be specified for a particular Route.

4.2.291.3 encountered_object

The encountered_object specifies an ordered list of physical or abstract items the route comes in touch.

Each encountered_object may be one of the following: Connectivity_definition (see 4.2.61), Device (see 4.2.88), Function_unit (see 4.2.148), Functional_connectivity_definition (see 4.2.152), Location (see 4.2.192), Physical_instance (see 4.2.243), Product_component (see 4.2.265), or Signal (see 4.2.309).

See 4.3.2049, 4.3.2050, 4.3.2051, 4.3.2052, 4.3.2053, 4.3.2055, 4.3.2056, and 4.3.2059 for the application assertions.

4.2.291.4 id

The id specifies the identifier of the Route.

4.2.291.5 version_id

The version_id specifies versioning information for the Route.

The version_id need not be specified for a particular Route.

4.2.292 Route_relationship

A Route_relationship is the relation between two Route (see 4.2.290) objects.

The data associated with a Route_relationship are the following:

- description;
- related;
- relating;
- relation_type.

4.2.292.1 description

The description specifies an alphanumeric string containing human-interpretable text that gives further details about the Route_relationship.

The description need not be specified for a particular Route_relationship.

4.2.292.2 related

The related specifies the second of the two Route (see 4.2.290) objects related by the Route_ - relationship.

See 4.3.2060 for the application assertion.

4.2.292.3 relating

The relating specifies the first of the two Route (see 4.2.290) objects related by the Route_ - relationship.

See 4.3.2061 for the application assertion.

4.2.292.4 relation_type

The relation_type specifies the meaning of the relationship. The value is either user defined or predefined.

The predefined value of relation_type is one of the following:

- alternate;
- decomposition;
- derivation;
- substitution.

NOTE 1 See 4.2.292.4.1 - 4.2.292.4.4 for the definition of each predefined value for relation_ - type.

4.2.292.4.1 alternate

alternate: The Route_relationship defines a relationship where the related Route (see 4.2.290) is an alternative to the relating Route (see 4.2.290).

NOTE 2 This concept refers to the possibility to replace the Route (see 4.2.290). The actual replacement is addressed by 'substitution'.

4.2.292.4.2 decomposition

decomposition: The Route_relationship defines a relationship where the related Route (see 4.2.290) is one of the components into which the relating Route (see 4.2.290) is divided.

4.2.292.4.3 derivation

derivation: The Route_relationship defines a deriving relationship where the related Route (see 4.2.290) is based on the relating Route (see 4.2.290).

4.2.292.4.4 substitution

substitution: The `Route_relationship` defines a relationship where the related `Route` (see 4.2.290) replaces the relating `Route` (see 4.2.290).

4.2.293 Routed_object

The `Routed_object` is an physical or abstract item to which routing information is assigned.

The data associated with a `Routed_object` are the following:

- `arrangement`;
- `associated_object`.

4.2.293.1 arrangement

The `arrangement` specifies an ordered list of sections that specifies the route of the `Routed_object`.

Each `arrangement` may be one of the following: `Free_segment` (see 4.2.144) or `Routed_segment` (see 4.2.293).

See 4.3.2064 and 4.3.2069 for the application assertions.

4.2.293.2 associated_object

The `associated_object` specifies the item to which the routing information applies.

Each `associated_object` may be one of the following: `Connectivity_definition` (see 4.2.61), `Device` (see 4.2.88), `Function_unit` (see 4.2.148), `Functional_connectivity_definition` (see 4.2.152), `Physical_instance` (see 4.2.243), or `Product_component` (see 4.2.265).

See 4.3.2062, 4.3.2063, 4.3.2065, 4.3.2066, 4.3.2067, and 4.3.2068 for the application assertions.

4.2.294 Routed_segment

A `Routed_segment` is a portion of a `Routed_object` (see 4.2.292) that has a well-defined course.

The data associated with a `Routed_segment` are the following:

- `course`;
- `description`;
- `id`.

4.2.294.1 course

The `course` specifies the way that is followed by the `Routed_segment`.

Each `course` may be one of the following: `Node` (see 4.2.208), `Route` (see 4.2.290), `Section` (see 4.2.296), or `Section_interface` (see 4.2.298).

ISO 10303-212:2001(E)

See 4.3.2070, 4.3.2071, 4.3.2072, and 4.3.2073 for the application assertions.

4.2.294.2 description

The description specifies an alphanumeric string containing human-interpretable text that gives further details about the Routed_segment.

The description need not be specified for a particular Routed_segment.

4.2.294.3 id

The id specifies the identifier of the Routed_segment.

4.2.295 Schematic_node

A Schematic_node is a type of Annotation_element (see 4.2.15) that describes that part of a pictorial presentation to which connecting lines or terminals of other symbols may be connected.

The data associated with a Schematic_node are the following:

- assigned_to;
- definition;
- position;
- rotation;
- scale.

4.2.295.1 assigned_to

The assigned_to specifies the User_defined_symbol (see 4.2.354) to which the Schematic_node is associated.

The assigned_to need not be specified for a particular Schematic_node.

See 4.3.2076 for the application assertion.

4.2.295.2 definition

The definition specifies the Typical_schematic_node (see 4.2.347) object that served as a template for the Schematic_node.

See 4.3.2075 for the application assertion.

4.2.295.3 position

The position specifies the location of the Schematic_node relative to the coordinate system of the associated User_defined_symbol (see 4.2.354).

See 4.3.2074 for the application assertion.

4.2.295.4 rotation

The rotation specifies the angle, measured counter-clockwise, between the horizontal axis of the coordinate system in which the Schematic_node is defined and the horizontal axis of the coordinate system into which the Schematic_node is being placed.

4.2.295.5 scale

The scale specifies the ratio between the size of the Schematic_node as defined and the size of the Schematic_node as presented.

4.2.296 Schematic_text

A Schematic_text is a type of Text (see 4.2.342) that is written information in schematic diagrams. It is based on predefined templates that define the layout of the text and may contain default text.

The data associated with a Schematic_text are the following:

- assigned_to;
- definition.

4.2.296.1 assigned_to

The assigned_to specifies the User_defined_symbol (see 4.2.354) to which the Schematic_node (see 4.2.294) is associated.

The assigned_to need not be specified for a particular Schematic_text.

Each assigned_to may be one of the following: Schematic_node (see 4.2.294) or User_defined_symbol (see 4.2.354).

See 4.3.2077 and 4.3.2079 for the application assertions.

4.2.296.2 definition

The definition specifies the template from which the Schematic_text is derived.

See 4.3.2078 for the application assertion.

4.2.297 Section

A Section describes a segment of a Route (see 4.2.290). A Section may be curved.

ISO 10303-212:2001(E)

NOTE 1 A Route (see 4.2.290) is understood as a sequence of vertices and edges, in which the edges are Section objects.

NOTE 2 Sections and Node (see 4.2.208) objects can be used to describe the three-dimensional route of a cable.

The data associated with a Section are the following:

- bending_radius;
- course;
- cross_section;
- description;
- id;
- implemented_by;
- length_of_section;
- space_factor;
- version_id;

4.2.297.1 bending_radius

The bending_radius specifies a quantity that characterizes the radius of the curves a piece of equipment laid in the Section needs to follow.

NOTE 1 If more than one Single_value (see 4.2.316) object is assigned different aspects of the bending radius are specified.

NOTE 2 The value of the 'bending_radius' attribute can be used to determine the required flexibility of a cable that is to be laid into the Section.

EXAMPLE To define a particular cabletray the typical and the minimum value of the bending radius are specified.

See 4.3.2083 for the application assertion.

4.2.297.2 course

The course specifies the path of the Section.

The course need not be specified for a particular Section.

See 4.3.2082 for the application assertion.

4.2.297.3 cross_sectional_area

The `cross_sectional_area` describes the transverse section of a Section in which the cabling can be placed.

NOTE If more than one `Cross_section` (see 4.2.65) object is assigned different aspects of the transverse section are specified.

EXAMPLE To define a particular cabletray the typical and the minimum value of the cross section are specified.

See 4.3.2080 for the application assertion.

4.2.297.4 description

The description specifies an alphanumeric string containing human-interpretable text that gives further details about the Section.

The description need not be specified for a particular Section.

4.2.297.5 id

The `id` specifies the identifier of the Section.

4.2.297.6 implemented_by

The `implemented_by` specifies the equipment that is used to realize the Section.

See 4.3.2081 for the application assertion.

4.2.297.7 length_of_section

The `length_of_section` specifies a measure of the longitudinal extent of the Section.

NOTE If more than one `Single_value` (see 4.2.316) object is assigned different aspects of the section's length are specified.

EXAMPLE To define a particular cabletray the typical, maximum, and minimum value of the `length_of_section` are specified.

See 4.3.2084 for the application assertion.

4.2.297.8 space_factor

The `space_factor` specifies the ratio between the usable cross section to the geometrical cross section of the Section.

ISO 10303-212:2001(E)

NOTE If more than one Single_value (see 4.2.316) object is assigned different aspects of the section's space factor are specified.

EXAMPLE To define a particular cabletray the typical and minimum value of the space_factor are specified.

See 4.3.2085 for the application assertion.

4.2.297.9 version_id

The version_id specifies versioning information for the Section.

The version_id need not be specified for a particular Section.

4.2.298 Section_end

The Section_end specifies one extremity of the associated Section (see 4.2.296).

The data associated with a Section_end are the following:

- id;
- kind;
- located_at;
- of_section.

4.2.298.1 id

The id specifies the identifier of the Section_end.

4.2.298.2 kind

The kind specifies the type of the Section_end. The value is either user defined or predefined.

The predefined value of kind is one of the following:

- flat oval;
- round;
- u shape.

NOTE See 4.2.298.2.1 - 4.2.298.2.3 for the definition of each predefined value for kind.

4.2.298.2.1 flat oval

flat oval: The cross section of the Section_end is as outlined in Figure 17.

4.2.298.2.2 round

round: The cross section of the Section_end is as outlined in Figure 17.

4.2.298.2.3 u shape

u shape: The cross section of the Section_end is as outlined in Figure 17.

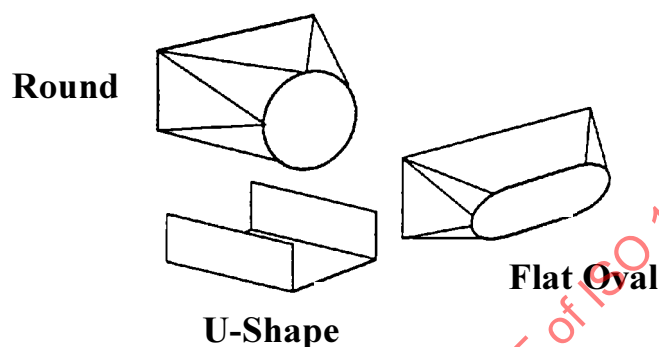

Figure 17 - Predefined section end shapes

The kind need not be specified for a particular Section_end.

4.2.298.3 located_at

The located_at specifies the position of the Section_end.

The located_at need not be specified for a particular Section_end.

See 4.3.2086 for the application assertion.

4.2.298.4 of_section

The of_section specifies the Section (see 4.2.296) to which the Section_end belongs.

See 4.3.2087 for the application assertion.

4.2.299 Section_interface

A Section_interface is a means to join Section (see 4.2.296) objects to each other.

ISO 10303-212:2001(E)

The data associated with a Section_interface are the following:

- cross_sectional_area;
- description;
- id;
- implemented_by;
- joins;
- located_at;
- space_factor;
- version_id.

4.2.299.1 cross_sectional_area

The cross_sectional_area specifies the transverse section of a Section_interface in which the cabling can be placed.

See 4.3.2088 for the application assertion.

4.2.299.2 description

The description specifies an alphanumeric string containing human-interpretable text that gives further details about the Section_interface.

The description need not be specified for a particular Section_interface.

4.2.299.3 id

The id specifies the identifier of the Section_interface.

4.2.299.4 implemented_by

The implemented_by specifies the equipment that realizes the Section_interface.

See 4.3.2089 for the application assertion.

4.2.299.5 joins

The joins specifies the Section_end (see 4.2.297) objects that are linked through the Section_interface.

See 4.3.2091 for the application assertion.

4.2.299.6 located_at

The located_at specifies the position of the Section_interface.

The `located_at` need not be specified for a particular `Section_interface`.

See 4.3.2090 for the application assertion.

4.2.299.7 space_factor

The `space_factor` specifies the ratio between the actually useable cross section to the geometrical cross section.

See 4.3.2092 for the application assertion.

4.2.299.8 version_id

The `version_id` specifies versioning information for the `Section_interface`.

The `version_id` need not be specified for a particular `Section_interface`.

4.2.300 Section_interface_relationship

A `Section_interface_relationship` is the relation between two `Section_interface` (see 4.2.298) objects.

The data associated with a `Section_interface_relationship` are the following:

- `description`;
- `related`;
- `relating`;
- `relation_type`.

4.2.300.1 description

The `description` specifies an alphanumeric string containing human-interpretable text that gives further details about the `Section_interface_relationship`.

The `description` need not be specified for a particular `Section_interface_relationship`.

4.2.300.2 related

The `related` specifies the second of the two `Section_interface` (see 4.2.298) objects related by the `Section_interface_relationship`.

See 4.3.2093 for the application assertion.

4.2.300.3 relating

The `relating` specifies the first of the two `Section_interface` (see 4.2.298) objects related by the `Section_interface_relationship`.

See 4.3.2094 for the application assertion.

4.2.300.4 relation_type

The relation_type specifies the meaning of the relationship. The value is either user defined or predefined.

The predefined value of relation_type is one of the following:

- alternate;
- decomposition;
- derivation;
- substitution;
- version hierarchy;
- version sequence.

NOTE 1 See 4.2.300.4.1 - 4.2.300.4.6 for the definition of each predefined value for relation_type.

4.2.300.4.1 alternate

alternate: The Section_interface_relationship defines a relationship where the related Section_interface (see 4.2.298) is a possible substitute to the relating Section_interface (see 4.2.298).

NOTE 2 This concept refers to the possibility to replace the Section_interface (see 4.2.298). The actual replacement is addressed by 'substitution'.

4.2.300.4.2 decomposition

decomposition: The Section_interface_relationship defines a relationship where the related Section_interface (see 4.2.298) is one of the components into which the relating Section_interface (see 4.2.298) is divided.

4.2.300.4.3 derivation

derivation: The Section_interface_relationship defines a deriving relationship where the related Section_interface (see 4.2.298) is based on the relating Section_interface (see 4.2.298).

4.2.300.4.4 substitution

substitution: The Section_interface_relationship defines a relationship where the related Section_interface (see 4.2.298) replaces the relating Section_interface (see 4.2.298).

4.2.300.4.5 version hierarchy

version hierarchy: The Section_interface_relationship defines a hierarchical relationship where the related Section_interface (see 4.2.298) is a subversion of the relating Section_interface (see 4.2.298).

EXAMPLE 1 Revisions 1.1 and 1.2 of a Section_interface (see 4.2.298).

4.2.300.4.6 version sequence

version sequence: The `Section_interface_relationship` defines a relationship where the relating `Section_interface` (see 4.2.298) is the preceding version and the related `Section_interface` (see 4.2.298) is the following version.

NOTE 3 The relationship does not imply inheritance of any kind between the application objects that are related.

EXAMPLE 2 'version sequence' is used, whenever a new version is prepared, e.g., 'version 1.0' is the preceding version for the following 'version 2.0'.

4.2.301 Section_relationship

A `Section_relationship` is a relation between two `Section` (see 4.2.296) objects.

The data associated with an `Section_relationship` are the following:

- description;
- related;
- relating;
- relation_type.

4.2.301.1 description

The description specifies an alphanumerical string containing human-interpretable text that gives further details about the `Section_relationship`.

The description need not be specified for a particular `Section_relationship`.

4.2.301.2 related

The related specifies the second of the two `Section` (see 4.2.296) objects related by the `Section_relationship`.

See 4.3.2095 for the application assertion.

4.2.301.3 relating

The relating specifies the first of the two `Section` (see 4.2.296) objects related by the `Section_relationship`.

See 4.3.2096 for the application assertion.

4.2.301.4 relation_type

The `relation_type` specifies the meaning of the relationship. The value is either user defined or predefined.

ISO 10303-212:2001(E)

The predefined value of `relation_type` is one of the following:

- alternate;
- decomposition;
- derivation;
- substitution;
- version hierarchy;
- version sequence.

NOTE 1 See 4.2.301.4.1 - 4.2.301.4.6 for the definition of each predefined value for `relation_type`.

4.2.301.4.1 alternate

alternate: The `Section_relationship` defines a relationship where the related Section (see 4.2.296) is a possible substitute to the relating Section (see 4.2.296).

NOTE 2 This concept refers to the possibility to replace the Section (see 4.2.296). The actual replacement is addressed by 'substitution'.

4.2.301.4.2 decomposition

decomposition: The `Section_relationship` defines a relationship where the related Section (see 4.2.296) is one of the components into which the relating Section (see 4.2.296) is divided.

4.2.301.4.3 derivation

derivation: The `Section_relationship` defines a deriving relationship where the related Section (see 4.2.296) is based on the relating Section (see 4.2.296).

4.2.301.4.4 substitution

substitution: The `Section_relationship` defines a relationship where the related Section (see 4.2.296) replaces the relating Section (see 4.2.296).

4.2.301.4.5 version hierarchy

version hierarchy: The `Section_relationship` defines a hierarchical relationship where the related Section (see 4.2.296) is a subversion of the relating Section (see 4.2.296).

EXAMPLE Revisions 1.1 and 1.2 of a Section (see 4.2.296).

4.2.301.4.6 version sequence

version sequence: The `Section_relationship` defines a succession of versions where the relating Section (see 4.2.296) is the preceding version, and the related Section (see 4.2.296) is the following version.

4.2.302 Security_classification

A Security_classification is a means to specify a security level for an physical or abstract item.

The data associated with a Security_classification are the following:

- is_applied_to;
- name;
- purpose;
- security_classification_level.

4.2.302.1 is_applied_to

The is_applied_to specifies the item to which the Security_classification is assigned.

Each is_applied_to may be one of the following: Activity (see 4.2.1), Activity_element (see 4.2.2), Activity_method_assignment (see 4.2.4), Activity_relationship (see 4.2.5), Alternate_item_relationship (see 4.2.11), Assembly_component_relationship (see 4.2.26), Assembly_substitute_relationship (see 4.2.28), Cable_pull_information (see 4.2.33), Class_structure_relationship (see 4.2.45), Classification_system (see 4.2.48), Complex_product (see 4.2.51), Complex_product_relationship (see 4.2.52), Composition_relationship (see 4.2.55), Configuration (see 4.2.56), Connectivity_allocation (see 4.2.60), Connectivity_definition (see 4.2.61), Connectivity_definition_relationship (see 4.2.62), Contract (see 4.2.63), Data_element (see 4.2.70), Data_element_association (see 4.2.71), Data_element_definition (see 4.2.72), Data_element_relationship (see 4.2.74), Design_discipline_item_definition (see 4.2.86), Device (see 4.2.88), Device_relationship (see 4.2.89), Document (see 4.2.101), Document_file (see 4.2.106), Document_file_relationship (see 4.2.107), Document_representation (see 4.2.110), Document_version (see 4.2.114), Document_version_relationship (see 4.2.115), Drawing (see 4.2.119), Drawing_sequence (see 4.2.121), Drawing_sheet (see 4.2.122), Drawing_sheet_relationship (see 4.2.124), Function_definition (see 4.2.145), Function_definition_relationship (see 4.2.146), Function_interface (see 4.2.147), Function_unit (see 4.2.148), Function_unit_relationship (see 4.2.149), Function_version (see 4.2.150), Function_version_relationship (see 4.2.151), Functional_connectivity_definition (see 4.2.152), Functional_connectivity_definition_relationship (see 4.2.153), Functional_unit_allocation (see 4.2.154), Generic_note (see 4.2.159), Interface (see 4.2.170), Interface_port (see 4.2.171), Interface_terminal (see 4.2.174), Item_definition_relationship (see 4.2.179), Item_version (see 4.2.182), Item_version_relationship (see 4.2.183), Location (see 4.2.192), Location_relationship (see 4.2.194), Manufacturing_configuration (see 4.2.198), Marking (see 4.2.199), Node (see 4.2.208), Node_relationship (see 4.2.209), Notification (see 4.2.213), Notification_relationship (see 4.2.214), Offered_function_allocation (see 4.2.220), Path (see 4.2.232), Path_node (see 4.2.233), Path_node_relationship (see 4.2.234), Path_relationship (see 4.2.235), Physical_assembly_relationship (see 4.2.241), Physical_instance (see 4.2.243), Port (see 4.2.247), Port_allocation (see 4.2.248), Preferred_item_allocation (see 4.2.258), Preferred_item_terminal_allocation (see 4.2.259), Process_variable (see 4.2.260), Process_variable_relationship (see 4.2.261), Product_class (see 4.2.263), Product_identification (see 4.2.268), Product_structure_relationship (see 4.2.270), Project (see 4.2.271), Requirement (see 4.2.285), Route (see 4.2.290), Route_relationship (see 4.2.291), Section (see 4.2.296), Section_end (see 4.2.297), Section_interface (see 4.2.298), Section_interface_relationship (see 4.2.299), Section_relationship (see 4.2.300), Signal (see 4.2.309), Signal_relationship (see 4.2.311), Signal_value (see 4.2.313), Specification (see 4.2.323), Specification_category (see 4.2.324), Technical_system (see 4.2.336), Technical_system_

ISO 10303-212:2001(E)

relationship (see 4.2.337), Terminal (see 4.2.338), Work_order (see 4.2.364), or Work_request (see 4.2.365).

See 4.3.2097, 4.3.2098, 4.3.2099, 4.3.2100, 4.3.2101, 4.3.2102, 4.3.2103, 4.3.2104, 4.3.2105, 4.3.2106, 4.3.2107, 4.3.2108, 4.3.2109, 4.3.2110, 4.3.2111, 4.3.2112, 4.3.2113, 4.3.2114, 4.3.2115, 4.3.2116, 4.3.2117, 4.3.2118, 4.3.2119, 4.3.2120, 4.3.2121, 4.3.2122, 4.3.2123, 4.3.2124, 4.3.2125, 4.3.2126, 4.3.2127, 4.3.2128, 4.3.2129, 4.3.2130, 4.3.2131, 4.3.2132, 4.3.2133, 4.3.2134, 4.3.2135, 4.3.2136, 4.3.2137, 4.3.2138, 4.3.2139, 4.3.2140, 4.3.2141, 4.3.2142, 4.3.2143, 4.3.2144, 4.3.2145, 4.3.2146, 4.3.2147, 4.3.2148, 4.3.2149, 4.3.2150, 4.3.2151, 4.3.2152, 4.3.2153, 4.3.2154, 4.3.2155, 4.3.2156, 4.3.2157, 4.3.2158, 4.3.2159, 4.3.2160, 4.3.2161, 4.3.2162, 4.3.2163, 4.3.2164, 4.3.2165, 4.3.2166, 4.3.2167, 4.3.2168, 4.3.2169, 4.3.2170, 4.3.2171, 4.3.2172, 4.3.2173, 4.3.2174, 4.3.2175, 4.3.2176, 4.3.2177, 4.3.2178, 4.3.2179, 4.3.2180, 4.3.2181, 4.3.2182, 4.3.2184, 4.3.2185, 4.3.2186, 4.3.2187, 4.3.2188, 4.3.2189, 4.3.2190, 4.3.2191, 4.3.2192, and 4.3.2193 for the application assertions.

4.2.302.2 name

The name specifies the identifier of the Security_classification.

4.2.302.3 purpose

The purpose specifies the rationale behind the Security_classification.

4.2.302.4 security_classification_level

The security_classification_level specifies the Security_level (see 4.2.302) associated with the item.

See 4.3.2183 for the application assertion.

4.2.303 Security_level

A Security_level is the specification of a level of security within some Security_classification (see 4.2.301).

NOTE The values of Security_level are company specific.

The data associated with a Security_level are the following:

- level_name;
- used_classification_system.

4.2.303.1 level_name

The level_name specifies the word or abbreviation used to refer to the Security_level.

4.2.303.2 used_classification_system

The used_classification_system specifies the Classification_system (see 4.2.48) that contains the information about how to interpret the name of the Security_level.

The used_classification_system need not be specified for a particular Security_level.

See 4.3.2194 for the application assertion.

4.2.304 Selected_device

A Selected_device is a type of Device (see 4.2.88) that is the occurrence of a Design_discipline_item_definition (see 4.2.86) which depends on certain constraints.

EXAMPLE To minimize the concentricity error of a wheel, weights are attached to the rim; this set of weights is a Selected_device. The quantity, as well as the position of these weights, depends on the concentricity behaviour of each particular wheel as manufactured and tested.

The data associated with a Selected_device are the following:

- selected_quantity;
- selection_control.

4.2.304.1 selected_quantity

The selected_quantity specifies the number of occurrences forseen as Selected_device.

NOTE If the quantity is to be specified as a minimum or a maximum, then the Value_limit (see 4.2.358) object may be used.

See 4.3.2195 for the application assertion.

4.2.304.2 selection_control

The selection_control specifies the constraint that has to be evaluated for the Selected_device.

EXAMPLE The information 'balancing the wheel' is an example for a selection_control.

4.2.305 Serial_configuration

A Serial_configuration is a type of Manufacturing_configuration (see 4.2.198) that is planned to apply from a given serial number of the product for whose characteristic the Serial_configuration identifies a solution.

The data associated with a Serial_configuration are the following:

- serial_end_number;
- serial_start_number.

4.2.305.1 serial_end_number

The serial_end_number specifies the serial number of that instance of the product that is the last instance for which the Serial_configuration applies.

The serial_end_number need not be specified for a particular Serial_configuration.

4.2.305.2 serial_start_number

The serial_start_number specifies the serial number of that instance of the product that is the first instance for which the Serial_configuration applies.

4.2.306 Set_of_notes

A Set_of_notes is a type of Generic_note (see 4.2.159) that is a collection of Note (see 4.2.210) objects.

The data associated with a Set_of_notes are the following:

- grouped_notes.

4.2.306.1 grouped_notes

The grouped_notes specifies the Generic_note (see 4.2.159) objects that are collected by a Set_of_notes.

See 4.3.2196 for the application assertion.

4.2.307 Shape

A Shape is the reference to the specification of the external form of a piece of equipment.

The data associated with a Shape are the following:

- id.

4.2.307.1 id

The id specifies the identifier of the Shape.

4.2.308 Shape_assignment

A Shape_assignment is a relation that associates a Shape (see 4.2.306) with an item.

NOTE If a shape is assigned to a functional item, the shape specifies the volume of space required to provide this service.

The data associated with a Shape_assignment are the following:

- assigned_shape;
- associated_item;
- description;
- role.

4.2.308.1 assigned_shape

The assigned_shape specifies the Shape (see 4.2.306) object assigned to the item.

See 4.3.2211 for the application assertion.

4.2.308.2 associated_item

The associated_item specifies the item with which the Shape (see 4.2.306) is associated.

Each associated_item may be one of the following: Connectivity_definition (see 4.2.61), Design_discipline_item_definition (see 4.2.86), Device (see 4.2.88), Function_definition (see 4.2.145), Function_unit (see 4.2.148), Functional_connectivity_definition (see 4.2.152), Interface_port (see 4.2.171), Interface_terminal (see 4.2.174), Location (see 4.2.192), Physical_instance (see 4.2.243), Port (see 4.2.247), Product_component (see 4.2.265), Section (see 4.2.296), Section_interface (see 4.2.298), Technical_system (see 4.2.336), or Terminal (see 4.2.338).

See 4.3.2197, 4.3.2198, 4.3.2199, 4.3.2200, 4.3.2201, 4.3.2202, 4.3.2203, 4.3.2204, 4.3.2205, 4.3.2206, 4.3.2207, 4.3.2208, 4.3.2209, 4.3.2210, 4.3.2212, and 4.3.2213 for the application assertions.

4.2.308.3 description

The description specifies an alphanumeric string containing human-interpretable text that gives further details about the Shape_assignment.

The description need not be specified for a particular Shape_assignment.

4.2.308.4 role

The role specifies the relationship between the item and the assigned shape. The value is either user defined or predefined.

The predefined value of role is one of the following:

- body shape;
- mounting space;
- safety space.

NOTE See 4.2.308.4.1 - 4.2.308.4.3 for the definition of each predefined value for relation_type.

4.2.308.4.1 body shape

body shape: The Shape (see 4.2.306) specifies the form of the associated item.

4.2.308.4.2 mounting space

mounting space: The Shape (see 4.2.306) specifies the space required to put the item into position.

ISO 10303-212:2001(E)

4.2.308.4.3 safety space

safety space: The Shape (see 4.2.306) specifies the form of the safety zone required for the associated item.

4.2.309 Sheet_placed_annotation

A Sheet_placed_annotation is a type of Draughting_annotation (see 4.2.116) that is located in the coordinate system of the drawing sheet.

The data associated with a Sheet_placed_annotation are the following:

- annotation_layers;
- annotation_visibility.

4.2.309.1 annotation_layers

The annotation_layers specifies the layers that contain the annotation.

See 4.3.2214 for the application assertion.

4.2.309.2 annotation_visibility

The annotation_visibility specifies whether or not each piece of annotation placed within the drawing sheet is visible.

See 4.3.2215 for the application assertion.

4.2.310 Signal

A Signal is the physical representation of a message or an information flow being generated, processed, or conveyed within an electrotechnical system.

NOTE 1 To be processed by an electrotechnical system a Process_variable (see 4.2.260) needs to be converted into a Signal.

EXAMPLE 1 A temperature sensor converts the temperature of a fluid into an electrical current that is represented by a Signal. The Signal thus informs about the height of the temperature.

NOTE 2 By associating Signal_value (see 4.2.313) objects to the Signal specific values of a Process_variable (see 4.2.260) can be assigned to characteristic values of the Signal.

EXAMPLE 2 A temperature of 100⁰ C is represented by a Signal_value (see 4.2.313) of 5 V.

NOTE 3 By associating General_classification (see 4.2.156) objects to Signal the type of the Signal can be specified.

EXAMPLE 3 A Signal is categorized to be a 32 bit wide and to be of type 'input'.

The data associated with a Signal are the following:

- associated_parameter;
- description;
- extended_designation;
- id;
- signal_level_indicator;
- version_id.

4.2.310.1 associated_parameter

The associated_parameter specifies the process variable about which the Signal informs.

See 4.3.2216 for the application assertion.

4.2.310.2 description

The description specifies an alphanumerical string containing human-interpretable text that gives further details about the Signal.

The description need not be specified for a particular Signal.

4.2.310.3 extended_designation

The extended_designation specifies a structured label for the Signal.

NOTE The label assigned through extended_designation shall be identical to the label assigned by the 'id' attribute.

EXAMPLE IEC 61175 specifies designations for signals and connections.

ISO 10303-212:2001(E)

The extended_designation need not be specified for a particular Signal.

See 4.3.2217 for the application assertion.

4.2.310.4 id

The id specifies the identifier of the Signal.

4.2.310.5 signal_level_indicator

The signal_level_indicator specifies the logical state of the signal that carries the information.

The signal_level_indicator need not be specified for a particular Signal.

4.2.310.6 version_id

The version_id specifies versioning information for the Signal.

The version_id need not be specified for a particular Signal.

4.2.311 Signal_designation

A Signal_designation is a type of Object_designation (see 4.2.217) that is a reference designation which uniquely identifies a signal within its scope.

4.2.312 Signal_relationship

A Signal_relationship is the relation between two Signal (see 4.2.309) objects.

The data associated with a Signal_relationship are the following:

- description;
- related;
- relating;
- relation_type.

4.2.312.1 description

The description specifies an alphanumeric string containing human-interpretable text that gives further details about the Signal_relationship.

The description need not be specified for a particular Signal_relationship.

4.2.312.2 related

The related specifies the second of the two Signal (see 4.2.309) objects related by the Signal_relationship.

See 4.3.2218 for the application assertion.

4.2.312.3 relating

The relating specifies the first of the two Signal (see 4.2.309) objects related by the Signal_ relationship.

See 4.3.2219 for the application assertion.

4.2.312.4 relation_type

The relation_type specifies the meaning of the relationship. The value is either user defined or predefined.

The predefined value of relation_type is one of the following:

- alternate;
- decomposition;
- derivation;
- substitution;
- redundancy;
- version hierarchy.

NOTE 1 See 4.2.312.4.1 - 4.2.312.4.6 for the definition of each predefined value for relation_type.

4.2.312.4.1 alternate

alternate: The Signal_relationship defines a relationship where the related Signal (see 4.2.309) is a possible substitute to the relating Signal (see 4.2.309).

NOTE 2 This concept refers to the possibility to replace the Signal (see 4.2.309). The actual replacement is addressed by 'substitution'.

4.2.312.4.2 decomposition

decomposition: The Signal_relationship defines a relationship where the related Signal (see 4.2.309) is one of the components into which the relating Signal (see 4.2.309) is divided.

NOTE In the case in which a signal acts as a carrier for other signals, it can be decomposed into these signals.

4.2.312.4.3 derivation

derivation: The Signal_relationship defines a deriving relationship where the related Signal (see 4.2.309) is based on the relating Signal (see 4.2.309).

ISO 10303-212:2001(E)

NOTE 1 A `Signal_relationship` with `relation_type` 'derivation' can be used to indicate the transfer function of a module. In such a case the input and output signal are associated through an instance of `Signal_relationship`. The 'description' attribute of that instance may contain the specification of the transfer function as a mathematical function.

NOTE 2 To avoid a shower of signals a summary signal can be derived from the cascade of signals that occur when a piece of equipment fails.

EXAMPLE A system used to keep a drive cool consists of a water pump, a radiator, and several sensors to monitor the system. An event that causes all of the water to leak out of the cooling system causes a number of signals. The temperature of the engine raises, the water pressure drops, and the emergency shutdown of the drive takes place. These three individual `Signal` (see 4.2.309) objects may be combined into a single `Signal` (see 4.2.309) object, which simply states that the drive has stopped, by relating the three `Signal` (see 4.2.309) objects to the summary `Signal` (see 4.2.309) through three `Signal_relationship` objects with `relation_type` 'derivation'.

4.2.312.4.4 substitution

substitution: The `Signal_relationship` defines a relationship where the related `Signal` (see 4.2.309) replaces the relating `Signal` (see 4.2.309).

4.2.312.4.5 redundancy

redundancy: The `Signal_relationship` defines a relationship where the related `Signal` (see 4.2.309) is replicated by the relating `Signal` (see 4.2.309).

EXAMPLE To provide for a fail-safe service a `Signal` (see 4.2.309) is replicated. If one `Signal` (see 4.2.309) is disturbed, the other is still readable.

4.2.312.4.6 version hierarchy

version hierarchy: The `Signal_relationship` defines a hierarchical relationship where the related `Signal` (see 4.2.309) is a subversion of the relating `Signal` (see 4.2.309).

EXAMPLE Revision 1.1 and 1.2 of a signal.

4.2.313 `Signal_system_assignment`

A `Signal_system_assignment` is a relation that associates a `Signal` (see 4.2.309) with a physical or abstract item that processes or transmits the `Signal` (see 4.2.309).

The data associated with a `Signal_system_assignment` are the following:

- `associated_signal`;
- `associated_system`;
- `description`;
- `role`.

4.2.313.1 associated_signal

The `associated_signal` specifies the `Signal` (see 4.2.309).

See 4.3.2228 for the application assertion.

4.2.313.2 associated_system

The `associated_system` specifies the item that processes or transmits the `Signal` (see 4.2.309).

Each `associated_system` may be one of the following: `Connectivity_definition` (see 4.2.61), `Design_discipline_item_definition` (see 4.2.86), `Device` (see 4.2.88), `Function_definition` (see 4.2.145), `Function_unit` (see 4.2.148), `Functional_connectivity_definition` (see 4.2.152), `Physical_instance` (see 4.2.243), `Port` (see 4.2.247), `Technical_system` (see 4.2.336), or `Terminal` (see 4.2.338).

See 4.3.2220, 4.3.2221, 4.3.2222, 4.3.2223, 4.3.2224, 4.3.2225, 4.3.2226, 4.3.2227, 4.3.2229, and 4.3.2230 for the application assertions.

4.2.313.3 description

The `description` specifies an alphanumeric string containing human-interpretable text that gives further details about the `Signal_system_assignment`.

The `description` need not be specified for a particular `Signal_system_assignment`.

4.2.313.4 role

The `role` specifies the relationship between the signal and the associated system. The value is either user defined or predefined.

ISO 10303-212:2001(E)

The predefined value of role is one of the following:

- amplifier;
- monitor;
- source;
- target;
- transmitter.

NOTE See 4.2.313.4.1 - 4.2.313.4.5 for the definition of each predefined value for role.

4.2.313.4.1 amplifier

amplifier: The signal is boosted within the assigned system.

4.2.313.4.2 monitor

monitor: The signal is observed within the assigned system.

4.2.313.4.3 source

source: The assigned system acts as a source for the signal.

EXAMPLE A sensor can be a source for a signal.

4.2.313.4.4 target

target: The assigned system acts as a target for the signal.

EXAMPLE A screen that visualizes a message can be a target for a signal.

4.2.313.4.5 transmitter

transmitter: The signal is transferred within the assigned system.

4.2.314 Signal_value

A Signal_value is the measure of a signal.

NOTE 1 By association Signal_value objects the characteristics of a Signal (see 4.2.309) can be laid down.

EXAMPLE 1 A Signal (see 4.2.309) can go from 0 to 10 mA with a linear characteristic.

NOTE 2 By associating Signal_value objects to the Signal (see 4.2.309) specific values of a Process_variable (see 4.2.260) can be assigned to characteristic values of the Signal (see 4.2.309).

EXAMPLE 2 A temperature of 100⁰ C is represented by a Signal_value of 5 V.

The data associated with a Signal_value are the following:

- associated_signal;
- characteristic;
- description;
- id;
- value_of_signal;
- valued_parameter.

4.2.314.1 associated_signal

The associated_signal specifies the Signal (see 4.2.309) to which the Signal_value applies.

See 4.3.2233 for the application assertion.

4.2.314.2 characteristic

The characteristic specifies how the Signal_value depends on the Process_variable (see 4.2.260) that is assigned through the associated_parameter. The value is either user defined or predefined.

The predefined value of characteristic is one of the following:

- linear.

NOTE 3 See 4.2.314.2.1 for the definition of each predefined value for characteristic.

4.2.314.2.1 linear

linear: The equation between the value of the Process_variable (see 4.2.260) and the Signal_value gives a straight line when plotted on a graph.

EXAMPLE 3 A temperature sensor with a linear transfer function will cause a linear dependency between the value of the associated Process_variable (see 4.2.260) characterizing the temperature and the associated Signal_value.

The characteristic need not be specified for a particular Signal_value.

4.2.314.3 description

The description specifies an alphanumeric string containing human-interpretable text that gives further details about the Signal_value.

The description need not be specified for a particular Signal_value.

4.2.314.4 id

The id specifies the identifier of the Signal_value.

4.2.314.5 value_of_signal

The `value_of_signal` specifies the numerical measure of the associated `Signal` (see 4.2.309).

See 4.3.2231 for the application assertion.

4.2.314.6 valued_parameter

The `valued_parameter` specifies a `Process_variable` (see 4.2.260) object that corresponds to the `Signal_value`.

The `valued_parameter` need not be specified for a particular `Signal_value`.

See 4.3.2232 for the application assertion.

4.2.315 Single_device

A `Single_device` is a type of `Device` (see 4.2.88) that is an individual piece of equipment.

4.2.316 Single_function_unit

A `Single_function_unit` is a type of `Function_unit` (see 4.2.148) that is an individual functional module.

4.2.317 Single_value

A `Single_value` is a type of `Data_element_value` (see 4.2.76) that specifies a distinct value.

The data associated with a `Single_value` are the following:

— `value_of_single_value`.

4.2.317.1 value_of_single_value

The `value_of_single_value` specifies the actual measure of the `Single_value`.

Each `value_of_single_value` may be one of the following: `Binary_value` (see 4.2.29), `Logical_value` (see 4.2.195), `String_value` (see 4.2.331), or `Value_with_unit` (see 4.2.360).

See 4.3.2234, 4.3.2235, 4.3.2236, and 4.3.2237 for the application assertions.

4.2.318 Solid_fill_area

A `Solid_fill_area` is a type of `Fill_area_appearance` (see 4.2.140) that uniformly fills the fill area to which the appearance is applied.

The data associated with a `Solid_fill_area` are the following:

— `fill_colour`.

4.2.318.1 fill_colour

The fill_colour specifies the colour definition that is uniformly applied to the fill area.

See 4.3.2238 for the application assertion.

4.2.319 Solution_instance_assignment

A Solution_instance_assignment is a relation that associates an Alternative_solution (see 4.2.12) with the items that implement the solution.

The data associated with a Solution_instance_assignment are the following:

- instance;
- solution.

4.2.319.1 instance

The instance specifies the item that implements the Alternative_solution (see 4.2.12).

Each instance may be one of the following: Node (see 4.2.208), Notification (see 4.2.213), Path (see 4.2.232), Path_node (see 4.2.233), Route (see 4.2.290), Section (see 4.2.296), Section_end (see 4.2.297), Section_interface (see 4.2.298), Signal (see 4.2.309), or Technical_system (see 4.2.336).

See 4.3.2240, 4.3.2241, 4.3.2242, 4.3.2243, 4.3.2244, 4.3.2245, 4.3.2246, 4.3.2247, 4.3.2248, and 4.3.2249 for the application assertions.

4.2.319.2 solution

The solution specifies the Alternative_solution (see 4.2.12) object.

See 4.3.2239 for the application assertion.

4.2.320 Specific_document_classification

A Specific_document_classification is a classification of a Document (see 4.2.101) with respect to specific criteria. The specific criteria are covered in the 'classification_name' attribute.

The data associated with a Specific_document_classification are the following:

- associated_document;
- classification_name;
- description.

4.2.320.1 associated_document

The associated_document the associated_document specifies the Document (see 4.2.101) with which a particular Specific_document_classification is associated.

See 4.3.2250 for the application assertion.

4.2.320.2 classification_name

The classification_name provides classification information.

NOTE The overall classification information is obtained by traversing the hierarchical tree established by Specific_item_classification_hierarchy (see 4.2.322).

The value is either user defined or predefined.

The predefined value of relation_type is one of the following:

- catalogue;
- manual;
- specification.

NOTE See 4.2.320.2.1 - 4.2.320.2.3 for the definition of each predefined value for relation_type.

4.2.320.2.1 catalogue

catalogue: The assigned document is the catalogue in which the associated object is listed.

EXAMPLE The document can be the catalogue of the manufacturer.

4.2.320.2.2 manual

manual: The assigned document is the handbook that is supplied for the associated object.

4.2.320.2.3 specification

specification: The assigned document specifies the considerations that lead to the actual design of the associated object.

4.2.320.3 description

The description specifies an alphanumeric string containing human-interpretable text that gives further details about the Specific_document_classification.

The description need not be specified for a particular Specific_document_classification.

4.2.321 Specific_document_classification_hierarchy

A Specific_document_classification_hierarchy is used to build up hierarchical structures of Specific_document_classification_hierarchy objects.

The data associated with a `Specific_document_classification` (see 4.2.319) are the following:

- `sub_classification`;
- `super_classification`.

4.2.321.1 sub_classification

The `sub_classification` specifies the lower level of `Specific_document_classification` (see 4.2.319) in `Specific_document_classification_hierarchy` that is included in the super class.

See 4.3.2251 for the application assertion.

4.2.321.2 super_classification

The `super_classification` specifies the higher level of `Specific_document_classification` (see 4.2.319) in `Specific_document_classification_hierarchy` that is included in the sub class.

See 4.3.2252 for the application assertion.

4.2.322 Specific_item_classification

A `Specific_item_classification` is a classification of an `Item` (see 4.2.178) with respect to specific criteria. The specific criteria are covered in the '`classification_name`' attribute.

NOTE 1 If an `Item` (see 4.2.178) requires classification by more than one criterion, several `Specific_item_classification` objects are associated to the same `Item` (see 4.2.178).

NOTE 2 For the attribute '`classification_name`' a set of predefined values is specified hereafter. If values other than the proposed ones are used, they should be of general classifying nature. This kind of classification ought not to be used to classify names or identifiers of objects, e.g., in order to classify part families; for this purpose `General_classification` (see 4.2.156) ought to be used.

The data associated with a `Specific_item_classification` are the following:

- `associated_item`;
- `classification_name`;
- `description`.

4.2.322.1 associated_item

The `associated_item` specifies the `Item` (see 4.2.178) with which a particular `Specific_item_classification` is associated.

See 4.3.2253 for the application assertion.

4.2.322.2 classification_name

The `classification_name` provides classification information.

ISO 10303-212:2001(E)

The following values shall be used:

- accessory;
- application control;
- assembly;
- collection;
- completely knocked down;
- detail;
- in process;
- part;
- prototype;
- raw material;
- regulated;
- safety;
- service;
- software;
- tool.

NOTE See 4.2.322.2.1 - 4.2.322.2.14 for the definition of each predefined value for classification_name.

4.2.322.2.1 accessory

accessory: This type of classification is used to indicate that an Item (see 4.2.178) shall be considered to be a supplementary portion of an electrotechnical system with the obligation to help the system to perform its function.

4.2.322.2.2 application control

application control: This type of classification is used to indicate that an Item (see 4.2.178) shall be considered under certification aspects; these aspects may be specified further by the 'description' attribute.

EXAMPLE 1 Prior to the release of a new car to the market, both function and quality of certain parts have to be certified by an authority, e.g., the department of transportation. For such Item (see 4.2.178) objects, certification requirements have to be considered during the design phase.

4.2.322.2.3 assembly

assembly: This type of classification shall be used for any Item (see 4.2.178) that has an Assembly_ - definition (see 4.2.27) provided for at least one of its versions, i.e., it is decomposed further.

4.2.322.2.4 completely knocked down

completely knocked down: This type of classification is used to indicate that an Item (see 4.2.178) is used in a production site that has assembling facilities only.

EXAMPLE 2 The 'completely knocked down' may indicate that the components are shipped to and assembled in a different country.

4.2.322.2.5 detail

detail: This type of classification shall be used for any Item (see 4.2.178) that has no Assembly_ - definition (see 4.2.27) provided for any of its versions, i.e., it is not further decomposed.

4.2.322.2.6 in process

in process: This type of classification is used to indicate that the Item (see 4.2.178) identifies an intermediate object in a manufacturing process.

4.2.322.2.7 part

part: The Item (see 4.2.178) plays the role of a component of relevance within the system.

4.2.322.2.8 prototype

prototype: This type of classification is used to indicate that the Item (see 4.2.178) identifies a prototype and is not intended for serial production.

4.2.322.2.9 raw material

raw material: The Item (see 4.2.178) plays the role of raw material.

4.2.322.2.10 regulated

regulated: This type of classification is used to indicate that for an Item (see 4.2.178) certain regulations have to be considered.

4.2.322.2.11 safety

safety: This type of classification is used to indicate that an Item (see 4.2.178) is relevant for safety purposes.

4.2.322.2.12 service

service: This type of classification is used to indicate that an Item (see 4.2.178) is relevant for service purposes.

4.2.322.2.13 software

software: This type of classification is used to indicate that an Item (see 4.2.178) is a program that can be executed on a particular kind of computer.

ISO 10303-212:2001(E)

4.2.322.2.14 tool

tool: The Item (see 4.2.178) plays the role of a tool.

4.2.322.3 description

The description specifies an alphanumeric string containing human-interpretable text that gives further details about the Specific_item_classification.

The description need not be specified for a particular Specific_item_classification.

4.2.323 Specific_item_classification_hierarchy

A Specific_item_classification_hierarchy is used to build up hierarchical structures of Specific_item_classification (see 4.2.321). The top level in the hierarchy shall be a 'part' or 'software'.

The data associated with a Specific_item_classification_hierarchy are the following:

- sub_classification;
- super_classification.

4.2.323.1 sub_classification

The sub_classification specifies the lower level of Specific_item_classification (see 4.2.321) in a Specific_item_classification_hierarchy that is included in the super class.

See 4.3.2254 for the application assertion.

4.2.323.2 super_classification

The super_classification specifies the higher level of Specific_item_classification (see 4.2.321) in a Specific_item_classification_hierarchy that includes the sub class.

See 4.3.2255 for the application assertion.

4.2.324 Specification

A Specification is a characteristic of a product. It discriminates one product from other constituents of the same Product_class (see 4.2.263). A Specification refers to a Specification_category (see 4.2.324) that completes the semantic of the Specification.

NOTE 1 A Specification may be a characteristic of the members of more than one Product_class (see 4.2.263) using Class_specification_association (see 4.2.44) objects.

NOTE 2 A Specification, in combination with a Configuration (see 4.2.56), can be used to define the conditions under which an Item (see 4.2.178) is used for a product of a Product_class (see 4.2.263).

The data associated with a Specification are the following:

- category;
- description;
- id;
- name;
- package;
- version_id.

4.2.324.1 category

The category specifies the Specification_category (see 4.2.324) that completes the semantic of the Specification.

See 4.3.2256 for the application assertion.

4.2.324.2 description

The description specifies an alphanumerical string containing human-interpretable text that gives further details about the Specification.

The description need not be specified for a particular Specification.

4.2.324.3 id

The id specifies the identifier of the Specification.

4.2.324.4 name

The name specifies a speaking designation of the Specification.

The name need not be specified for a particular Specification.

4.2.324.5 package

The package specifies whether or not this Specification represents a package of Specification objects. A package is a set of Specification objects that can be defined by the marketing department. A package combines those Specification objects that shall be offered to the market as a set. In the case where package is 'true', exactly one Specification_inclusion (see 4.2.327) shall refer to this Specification as an if condition.

ISO 10303-212:2001(E)

NOTE Usually the members of a package belong to distinct Specification_category (see 4.2.324) objects.

4.2.324.6 version_id

The version_id specifies versioning information for the Specification.

The version_id need not be specified for a particular Specification.

4.2.325 Specification_category

A Specification_category is the definition of a set of Specification (see 4.2.323) objects for the same purpose.

The data associated with a Specification_category are the following:

- description;
- id;
- implicit_exclusive_condition.

4.2.325.1 description

The description specifies an alphanumeric string containing human-interpretable text that gives further details about the Specification_category.

4.2.325.2 id

The id specifies the identifier of the Specification_category.

4.2.325.3 implicit_exclusive_condition

The implicit_exclusive_condition specifies whether or not the Specification (see 4.2.323) objects within the Specification_category are mutually exclusive for the production of one particular product.

NOTE More complex conditions can be handled using Specification_expression (see 4.2.326) objects.

4.2.326 Specification_category_hierarchy

A Specification_category_hierarchy is used to build up hierarchical structures of Specification_category (see 4.2.324) objects.

The data associated with a Specification_category_hierarchy are the following:

- sub_category;
- super_category.

4.2.326.1 sub_category

The `sub_category` is the lower level of `Specification_category` (see 4.2.324) in `Specification_category_hierarchy`.

See 4.3.2257 for the application assertion.

4.2.326.2 super_category

The `super_category` is the higher level of `Specification_category` (see 4.2.324) in `Specification_category_hierarchy`.

See 4.3.2258 for the application assertion.

4.2.327 Specification_expression

A `Specification_expression` is a combination of `Specification` (see 4.2.323) objects formed by Boolean operations.

The data associated with a `Specification_expression` are the following:

- description;
- id;
- operand;
- operation.

4.2.327.1 description

The description specifies an alphanumerical string containing human-interpretable text that gives further details about the `Specification_expression`.

The description need not be specified for a particular `Specification_expression`.

4.2.327.2 id

The id specifies the identifier of the `Specification_expression`.

The id need not be specified for a particular `Specification_expression`.

4.2.327.3 operand

The operand specifies the operands of the Boolean operation that are either `Specification` (see 4.2.323) objects or other `Specification_expression` objects.

Each operand may be one of the following: `Specification` (see 4.2.323) or `Specification_expression`.

See 4.3.2259 and 4.3.2260 for the application assertions.

4.2.327.4 operation

The operation specifies the kind of Boolean operation.

ISO 10303-212:2001(E)

The value of operation is one of the following:

- and;
- not;
- oneof;
- or.

NOTE See 4.2.327.4.1 - 4.2.327.4.4 for the definition of each permissible value for operation.

4.2.327.4.1 and

and: All of the identified Specification (see 4.2.323) objects shall be used.

4.2.327.4.2 not

not: The identified Specification (see 4.2.323) shall not be used.

4.2.327.4.3 oneof

oneof: Exactly one of the identified Specification (see 4.2.323) objects shall be used.

4.2.327.4.4 or

or: A subset or all of the identified Specification (see 4.2.323) objects shall be used.

4.2.328 Specification_inclusion

A Specification_inclusion is the representation of the statement that the application of a Specification (see 4.2.323) or a Specification_expression (see 4.2.326) implies the inclusion of an additional Specification (see 4.2.323) or Specification_expression (see 4.2.326).

NOTE The Specification_inclusion is intended to complete the set of Specification (see 4.2.323) objects for a Product_specification (see 4.2.269) in order to enable the manufacturing of the product on the basis of an initial set of Specification (see 4.2.323) objects defined, e.g., by a customer order.

The data associated with a Specification_inclusion are the following:

- description;
- id;
- if_condition;
- included_specification.

4.2.328.1 description

The description specifies an alphanumeric string containing human-interpretable text that gives further details about the Specification_inclusion.

The description need not be specified for a particular Specification_inclusion.

4.2.328.2 id

The id specifies the identifier of the Specification_inclusion.

The id need not be specified for a particular Specification_inclusion.

4.2.328.3 if_condition

The if_condition specifies the Specification (see 4.2.323) or the Specification_expression (see 4.2.323) that serves as the condition for the inclusion.

Each if_condition may be one of the following: Specification (see 4.2.323) or Specification_expression (see 4.2.326).

See 4.3.2261 and 4.3.2263 for the application assertions.

4.2.328.4 included_specification

The included_specification specifies the Specification (see 4.2.323) or the Specification_expression (see 4.2.326) objects that are to be included.

NOTE In the case where the included_specification is a Specification_expression (see 4.2.326), i.e., an OR expression, several alternatives for Specification (see 4.2.323) may be included. In the case where more than one Specification (see 4.2.323) objects are to be included, a Specification_expression (see 4.2.326) of type AND shall be used.

Each included_specification may be one of the following: Specification (see 4.2.323) or Specification_expression (see 4.2.326).

See 4.3.2262 and 4.3.2264 for the application assertions.

4.2.329 Specified_device

A Specified_device is a type of Device (see 4.2.88) that is the mechanism to identify a certain Device (see 4.2.88) in a multi-level assembly structure that utilizes structural reuse of partial decompositions.

EXAMPLE A belt conveyor consists among others of the components front drive and rear drive. Both components contain a motor and some other components. In order to identify the motor of the front drive, the Specified_device object references motor as related_instance, front drive as upper_usage, and belt conveyor as assembly_context.

The object, which is referred by the 'definition' attribute of a Specified_device and the object which is referenced through the 'related_function_unit' attribute as 'definition', shall be the same.

The data associated with a Specified_device are the following:

ISO 10303-212:2001(E)

- assembly_context;
- related_device;
- upper_usage.

4.2.329.1 assembly_context

The assembly_context specifies an Assembly_definition (see 4.2.27) object in which the instance is used that is identified by this mechanism.

The assembly_context need not be specified for a particular Specified_device.

See 4.3.2265 for the application assertion.

4.2.329.2 related_device

The related_device specifies the Device (see 4.2.88) that is to be identified. The related_device shall not be of type Specified_device.

See 4.3.2266 for the application assertion.

4.2.329.3 upper_usage

The upper_usage specifies the Device (see 4.2.88) in which the item referred by related_instance occurs.

See 4.3.2267 for the application assertion.

4.2.330 Specified_function_unit

A Specified_function_unit is a type of Function_unit (see 4.2.148) that is the mechanism to identify a certain Function_unit (see 4.2.148) in a multi-level decomposition structure that utilizes structural reuse of partial decompositions.

EXAMPLE An audio-amplifier consists among others of the modules left-channel amplifier and right-channel amplifier. Both modules contain pre-amplifier and output amplifier. In order to identify the pre-amplifier of the left-channel amplifier, the Specified_function_unit object references pre-amplifier as related_instance, left-channel amplifier as upper_usage, and audio-amplifier as functional_context.

The object, which is referred by the 'definition' attribute of a Specified_function_unit and the object which is referenced through the 'related_function_unit' attribute as 'definition', shall be the same.

The data associated with a Specified_function_unit are the following:

- functional_context;
- related_function_unit;
- upper_usage.

4.2.330.1 functional_context

The functional_context specifies a Function_unit (see 4.2.148) object in which the instance identified by this mechanism is used.

The functional_context need not be specified for a particular Specified_function_unit.

See 4.3.2268 for the application assertion.

4.2.330.2 related_function_unit

The related_function_unit specifies the Function_unit (see 4.2.148) that is to be identified. The related_function_unit shall not be of type Specified_function_unit.

See 4.3.2269 for the application assertion.

4.2.330.3 upper_usage

The upper_usage specifies the Function_unit (see 4.2.148) in which the item referred by related_function_unit occurs.

See 4.3.2270 for the application assertion.

4.2.331 Storage_temperature

A Storage_temperature is the allowed ambient temperature of a component while the device is in storage.

NOTE Minimum and maximum of Storage_temperature may be specified by assigning a Value_range (see 4.2.359) object.

EXAMPLE The Storage_temperature of a notebook computer ranges from -20°C to 60°C, whereas the Operating_temperature (see 4.2.221) ranges from 5°C to 35°C.

The data associated with a Storage_temperature are the following:

- temperature.

4.2.331.1 temperature

The temperature specifies the value of the Storage_temperature.

See 4.3.2271 for the application assertion.

4.2.332 String_value

ISO 10303-212:2001(E)

A `String_value` represents a sequence of one or more alphanumeric characters.

The data associated with a `String_value` are the following:

- `value_of_string_value`.

4.2.332.1 `value_of_string_value`

The `value_of_string_value` specifies the content of the `String_value`.

4.2.333 `Structured_dimension_callout`

A `Structured_dimension_callout` is a type of `Dimension_callout` (see 4.2.94) that is a callout wherein each component is identified as having the semantics of prefix information, suffix information, a dimension symbol, a dimension unit, a dimension value, or tolerance information.

The data associated with a `Structured_dimension_callout` are the following:

- `dimension_value`;
- `prefix_callout`;
- `suffix_callout`;
- `symbol`;
- `tolerance_value`;
- `unit_text`.

4.2.333.1 `dimension_value`

The `dimension_value` specifies the text strings that present the actual value of the measurement.

See 4.3.2275 for the application assertion.

4.2.333.2 `prefix_callout`

The `prefix_callout` specifies information used in interpreting the dimension or its applicability and is physically located before the dimension value as the dimension is read.

The `prefix_callout` need not be specified for a particular `Structured_dimension_callout`.

See 4.3.2273 for the application assertion.

4.2.333.3 `suffix_callout`

The `suffix_callout` specifies information, physically located after the dimension value as the dimension is read, either used in interpreting the dimension or its applicability or used as additional information in conjunction with the dimension.

The `suffix_callout` need not be specified for a particular `Structured_dimension_callout`.

See 4.3.2274 for the application assertion.

4.2.333.4 symbol

The symbol specifies an Annotation_symbol (see 4.2.20) that is used in conjunction with the dimension value to clarify the meaning of the measurement.

The symbol need not be specified for a particular Structured_dimension_callout.

See 4.3.2272 for the application assertion.

4.2.333.5 tolerance_value

The tolerance_value specifies the text strings that present the tolerance information for the measurement.

See 4.3.2276 for the application assertion.

4.2.333.6 unit_text

The unit_text specifies the text strings that present the unit of measurement.

See 4.3.2277 for the application assertion.

4.2.334 Sub_group

A Sub_group is a type of Group_element (see 4.2.165) that is a collection of elements previously defined as a group.

The data associated with a Sub_group are the following:

- basis_group.

4.2.334.1 basis_group

The basis_group specifies the group that is used as a Sub_group.

See 4.3.2278 for the application assertion.

4.2.335 Supplier_solution

A Supplier_solution is a type of Alternative_solution (see 4.2.12) that is a solution where the supplier differs from other solutions for the same Product_component (see 4.2.265).

The data associated with a Supplier_solution are the following:

- probability_rate;
- supplier.

4.2.335.1 probability_rate

ISO 10303-212:2001(E)

The `probability_rate` specifies the share that is assigned to a supplier in the context of the base element.

The `probability_rate` need not be specified for a particular `Supplier_solution`.

4.2.335.2 supplier

The `supplier` specifies the supplier for a `Supplier_solution`.

See 4.3.2279 for the application assertion.

4.2.336 Technical_solution

A `Technical_solution` is a type of `Alternative_solution` (see 4.2.12) that is a solution where the functional requirements are fulfilled in a certain technical way.

The data associated with a `Technical_solution` are the following:

- `description`.

4.2.336.1 description

The `description` specifies an alphanumeric string containing human-interpretable text that gives further details about the `Technical_solution`.

4.2.337 Technical_system

A `Technical_system` is the overall system that is to be planned, designed, or commissioned and that contains electrotechnical aspects. The `Technical_system` groups the physical and abstract items that, as a whole, make up the overall system.

EXAMPLE The power distribution system of a ship may be a `Technical_system`.

The data associated with a `Technical_system` are the following:

- `contains`;
- `description`;
- `extended_designation`;
- `id`;
- `version_id`.

4.2.337.1 contains

The `contains` specifies the items that comprise the `Technical_system`.

Each `contains` may be one of the following: `Classification_system` (see 4.2.48), `Device` (see 4.2.88), `Document_representation` (see 4.2.110), `Function_unit` (see 4.2.148), `Notification` (see 4.2.213),

Physical_instance (see 4.2.243), Process_variable (see 4.2.260), Requirement (see 4.2.285), Route (see 4.2.290), or Signal (see 4.2.309).

See 4.3.2280, 4.3.2281, 4.3.2282, 4.3.2283, 4.3.2284, 4.3.2286, 4.3.2287, 4.3.2288, 4.3.2289, and 4.3.2290 for the application assertions.

4.2.337.2 description

The description specifies an alphanumeric string containing human-interpretable text that gives further details about the Technical_system.

The description need not be specified for a particular Technical_system.

4.2.337.3 extended_designation

The extended_designation specifies a structured label for the Technical_system.

NOTE The label assigned through extended_designation shall be identical to the label assigned by the 'id' attribute.

The extended_designation need not be specified for a particular Technical_system.

See 4.3.2285 for the application assertion.

4.2.337.4 id

The id specifies the identifier of the Technical_system.

4.2.337.5 version_id

The version_id specifies versioning information for the Technical_system.

The version_id need not be specified for a particular Technical_system.

4.2.338 Technical_system_relationship

A Technical_system_relationship is the relation between two Technical_system (see 4.2.336) objects.

The data associated with a Technical_system_relationship are the following:

- description;
- related;
- relating;
- relation_type.

4.2.338.1 description

The description specifies an alphanumeric string containing human-interpretable text that gives further details about the Technical_system_relationship.

ISO 10303-212:2001(E)

The description need not be specified for a particular `Technical_system_relationship`.

4.2.338.2 related

The `related` specifies the second of the two `Technical_system` (see 4.2.336) objects related by the `Technical_system_relationship`.

See 4.3.2291 for the application assertion.

4.2.338.3 relating

The `relating` specifies the first of the two `Technical_system` (see 4.2.336) objects related by the `Technical_system_relationship`.

See 4.3.2292 for the application assertion.

4.2.338.4 relation_type

The `relation_type` specifies the meaning of the relationship. The value is either user defined or predefined.

The predefined value of `relation_type` is one of the following:

- alternate;
- decomposition;
- derivation;
- substitution;
- redundancy.

NOTE 1 See 4.2.338.4.1 - 4.2.338.4.5 for the definition of each predefined value for `relation_type`.

4.2.338.4.1 alternate

`alternate`: The `Technical_system_relationship` defines a relationship where the related `Technical_system` (see 4.2.336) is a possible substitute to the relating `Technical_system` (see 4.2.336).

NOTE 2 This concept refers to the possibility to replace the `Technical_system` (see 4.2.336). The actual replacement is addressed by 'substitution'.

4.2.338.4.2 decomposition

`decomposition`: The `Technical_system_relationship` defines a relationship where the related `Technical_system` (see 4.2.336) is one of the components into which the relating `Technical_system` (see 4.2.336) is divided.

4.2.338.4.3 derivation

derivation: The `Technical_system_relationship` defines a deriving relationship where the related `Technical_system` (see 4.2.336) is based on the relating `Technical_system` (see 4.2.336).

4.2.338.4.4 substitution

substitution: The `Technical_system_relationship` defines a relationship where the related `Technical_system` (see 4.2.336) replaces the relating `Technical_system` (see 4.2.336).

4.2.338.4.5 redundancy

redundancy: The `Technical_system_relationship` defines a relationship where the related `Technical_system` (see 4.2.336) is replicated by the relating `Technical_system` (see 4.2.336).

EXAMPLE To provide for a fail-safe service a `Technical_system` (see 4.2.336) is replicated. If one `Technical_system` (see 4.2.336) fails, the other is still in service.

4.2.339 Terminal

A Terminal is the occurrence of an `Interface_terminal` (see 4.2.174) used to access a piece of equipment.

The data associated with a Terminal are the following:

- `associated_interface_terminal`;
- `description`;
- `extended_designation`;
- `id`;
- `implemented_by`;
- `terminal_of`.

4.2.339.1 associated_interface_terminal

The `associated_interface_terminal` specifies the `Interface_terminal` (see 4.2.174) that defines the access to the piece of equipment.

See 4.3.2294 for the application assertion.

4.2.339.2 description

The `description` specifies an alphanumeric string containing human-interpretable text that gives further details about the Terminal.

The `description` need not be specified for a particular Terminal.

4.2.339.3 extended_designation

The extended_designation specifies a structured label for the Terminal.

NOTE The label assigned through extended_designation shall be identical to the label assigned by the 'id' attribute.

The extended_designation need not be specified for a particular Terminal.

See 4.3.2297 for the application assertion.

4.2.339.4 id

The id specifies the identifier of the Terminal.

4.2.339.5 implemented_by

The implemented_by specifies the Device (see 4.2.88) objects that are used to implement the Terminal.

Each implemented_by may be one of the following: Device (see 4.2.88) or Physical_instance (see 4.2.243).

See 4.3.2293 and 4.3.2295 for the application assertions.

4.2.339.6 terminal_of

The terminal_of specifies the Single_device (see 4.2.314) to which the Terminal belongs.

See 4.3.2296 for the application assertion.

4.2.340 Terminal_relationship

A Terminal_relationship is the relation between two Terminal (see 4.2.338) objects.

The data associated with an Terminal_relationship are the following:

- description;
- related;
- relating;
- relation_type.

4.2.340.1 description

The description specifies an alphanumerical string containing human-interpretable text that gives further details about the Terminal_relationship.

The description need not be specified for a particular Terminal_relationship.

4.2.340.2 related

The related specifies the second of the two Terminal (see 4.2.338) objects related by the Terminal_ - relationship.

See 4.3.2298 for the application assertion.

4.2.340.3 relating

The relating specifies the first of the two Terminal (see 4.2.338) objects related by the Terminal_ - relationship.

See 4.3.2299 for the application assertion.

STANDARDSISO.COM : Click to view the full PDF of ISO 10303-212:2001

4.2.340.4 relation_type

The relation_type specifies the meaning of the relationship. The value is either user defined or predefined.

The predefined value of relation_type is one of the following:

- decomposition;
- redundancy.

NOTE See 4.2.340.4.1 and 4.2.340.4.2 for the definition of each predefined value for relation_type.

4.2.340.4.1 decomposition

decomposition: The Terminal_relationship defines a relationship where the related Terminal (see 4.2.338) is one of the components into which the relating Terminal (see 4.2.338) is broken down.

4.2.340.4.2 redundancy

redundancy: The Terminal_relationship defines a relationship where the related Terminal (see 4.2.338)(see 4.2.156) is replicated by the relating Terminal (see 4.2.338).

EXAMPLE To provide for a fail-safe service a Terminal (see 4.2.338) is replicated. If one Terminal (see 4.2.338) fails, the other is still in service.

4.2.341 Terminal_designation

A Terminal_designation is a type of Object_designation (see 4.2.217) that is a reference designation to identify an access node with respect to the function or product to which it belongs.

4.2.342 Terminator_symbol

A Terminator_symbol is a type of Predefined_symbol (see 4.2.255) that is applied to an annotation curve and used to identify the endpoint or Point of application of any annotation directed by that curve.

The predefined terminator symbols that shall be supported by all implementations of this part of ISO 10303 are shown in Figure 18. The orientation of the individual symbol, as positioned on a horizontal dimension line, is shown in Figure 18.

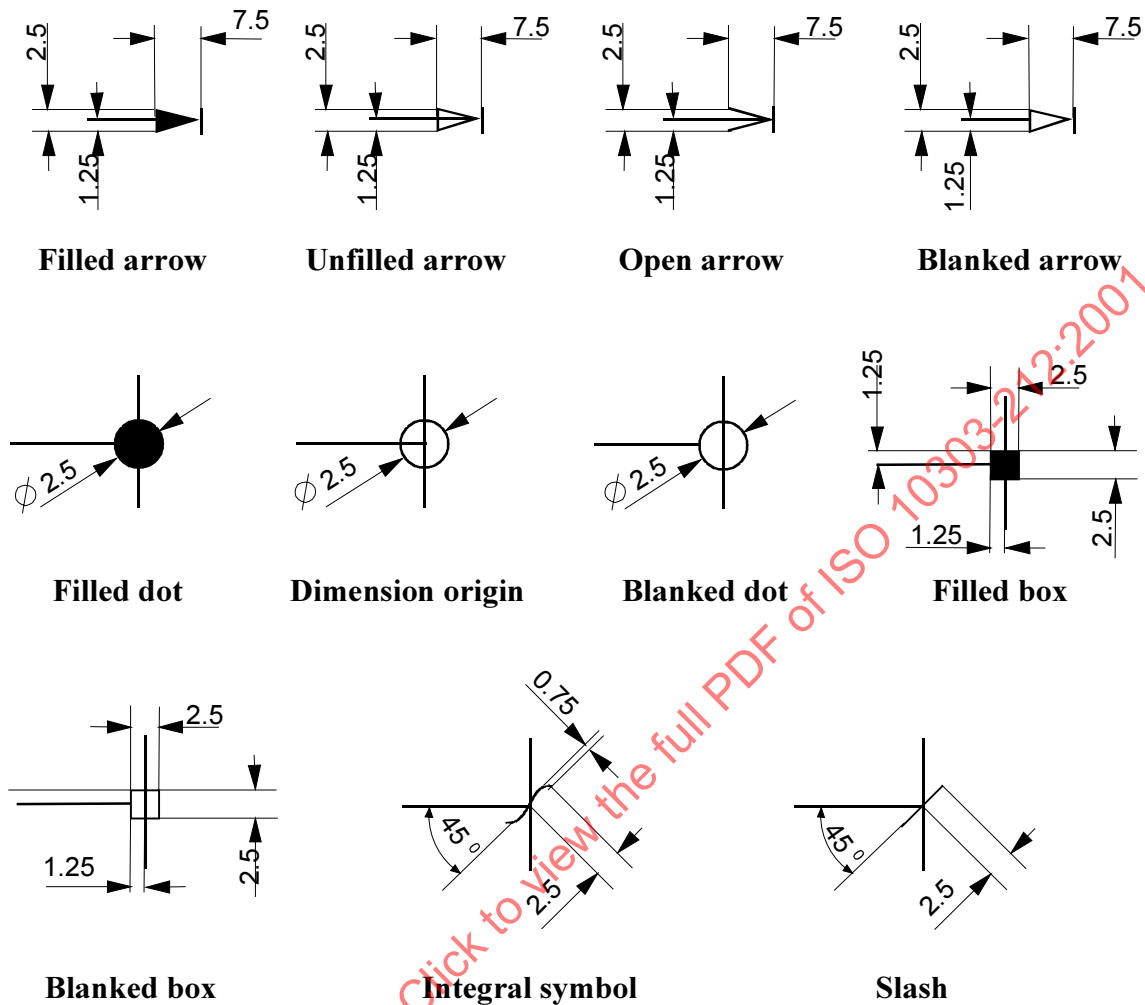

Figure 18 - Predefined terminator symbols

The data associated with a Terminator_symbol are the following:

— symbol_type.

4.2.342.1 symbol_type

The symbol_type specifies an alphanumerical string identifying the Terminator_symbol in accordance with the definitions given below.

ISO 10303-212:2001(E)

The value of `symbol_type` is one of the following:

- blanked arrow;
- blanked box;
- blanked dot;
- dimension origin;
- filled arrow;
- filled box;
- filled dot;
- integral symbol;
- open arrow;
- slash;
- unfilled arrow;
- unfilled dot.

NOTE See 4.2.342.1.1 - 4.2.342.1.12 for the definition of each permissible value for `symbol_type`.

4.2.342.1.1 blanked arrow

blanked arrow: The Terminator_symbol is depicted as three line segments that form an isosceles triangle. The origin of the symbol corresponds to the intersection point of the two equal sides. The annotation curve to which the symbol is applied acts as a bisector to the angle created by the two equal sides. The area within the symbol is blanked. The size and graphical representation of the symbol are shown in Figure 18.

4.2.342.1.2 blanked box

blanked box: The Terminator_symbol is depicted as four line segments that form a rectangle. The origin of the symbol is the geometric centre of the rectangle. The area within the symbol is blanked. The size and graphical representation of the symbol are shown in Figure 18.

4.2.342.1.3 blanked dot

blanked dot: The Terminator_symbol is depicted as a circle. The origin of the symbol is the centre of the circle. The area within the symbol is blanked. The size and graphical representation of the symbol are shown in Figure 18.

4.2.342.1.4 dimension origin

dimension origin: The Terminator_symbol is depicted as a circle. The origin of the symbol is the centre of the circle. The size and graphical representation of the symbol are shown in Figure 18.

4.2.342.1.5 filled arrow

filled arrow: The Terminator_symbol is depicted as three line segments that form an isosceles triangle. The origin of the symbol corresponds to the intersection point of the two equal sides. The annotation curve to which the symbol is applied, acts as a bisector to the angle created by the two equal sides. The area within the symbol is shaded. The size and graphical representation of the symbol are shown in Figure 18.

4.2.342.1.6 filled box

filled box: The Terminator_symbol is depicted as four line segments that form a rectangle. The origin of the symbol is the geometric centre of the rectangle. The area within the symbol is shaded. The size and graphical representation of the symbol are shown in Figure 18.

4.2.342.1.7 filled dot

filled dot: The Terminator_symbol is depicted as a circle. The origin of the symbol is the centre of the circle. The area within the symbol is shaded. The size and graphical representation of the symbol are shown in Figure 18.

4.2.342.1.8 integral symbol

integral symbol: The Terminator_symbol is depicted as one line segment forming two adjacent arcs. The origin of the symbol is the midpoint between the two arcs. The size and graphical representation of the symbol are shown in Figure 18.

4.2.342.1.9 open arrow

open arrow: The Terminator_symbol is depicted as three line segments that form an isosceles triangle where the third side of the triangle is blanked. The origin of the symbol corresponds to the intersection point of the two equal sides. The annotation curve to which the symbol is applied, acts as a bisector to the angle created by the two equal sides. The size and graphical representation of the symbol are shown in Figure 18.

4.2.342.1.10 slash

slash: The Terminator_symbol is depicted as a line segment with the midpoint of the segment being the origin and lying on the annotation curve to which it is applied. The size and graphical representation of the symbol are shown in Figure 18.

4.2.342.1.11 unfilled arrow

unfilled arrow: The Terminator_symbol is depicted as three line segments that form an isosceles triangle. The origin of the symbol corresponds to the intersection point of the two equal sides. The annotation curve to which the symbol is applied, acts as a bisector to the angle created by the two equal sides. The size and graphical representation of the symbol are shown in Figure 18.

4.2.342.1.12 unfilled dot

unfilled dot: The Terminator_symbol is depicted as a circle. The origin of the symbol is the centre of the circle. The size and graphical representation of the symbol are shown in Figure 18.

4.2.343 Text

A Text is a type of Annotation_element (see 4.2.15) that is a collection of characters that convey some human-interpretable information.

The data associated with a Text are the following:

- alignment;
- blanking_box;
- boundary_of_displayed_box;
- default_appearance;
- language_code;
- mirror_angle;
- surrounding_box.

NOTE See Figure 19 for an illustration of the blanking_box of text, the location and rotation of a text string, the alignment of text, and the surrounding_box of text.

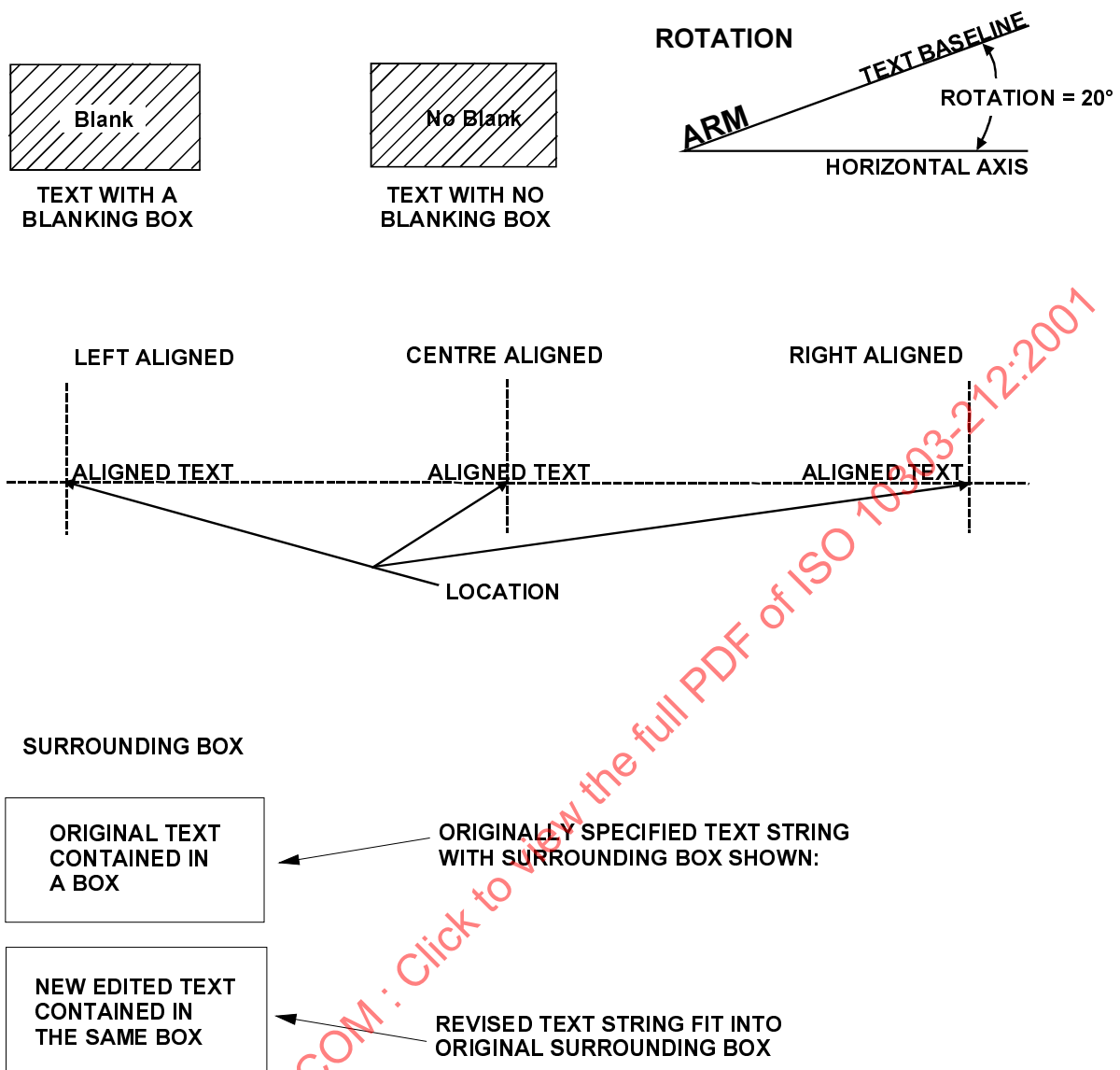

Figure 19 - Text characteristics

4.2.343.1 alignment

The alignment specifies the adjustment of the Text_string (see 4.2.345) objects contained in the Text with respect to their locations.

The alignment shall contain one of the following text strings:

4.2.343.1.1 centered

centered: The presentation of the Text_string (see 4.2.345) object is aligned to the middle.

4.2.343.1.2 left

left: The presentation of the Text_string (see 4.2.345) object is aligned to the left side.

ISO 10303-212:2001(E)

4.2.343.1.3 right

right: The presentation of the Text_string (see 4.2.345) object is aligned to the right side.

4.2.343.2 blanking_box

The blanking_box specifies an area that the text occupies and is used to suppress the visual presentation of all other elements that are within this area.

The blanking_box need not be specified for a particular Text.

See 4.3.2301 for the application assertion.

4.2.343.3 boundary_of_displayed_box

The boundary_of_displayed_box specifies the border of a rectangular box, composed of annotation curves, that encloses text where one side of the box is parallel to the text baseline.

See 4.3.2300 for the application assertion.

4.2.343.4 default_appearance

The default_appearance specifies the preselected appearance of the text when no alternative is specified by the user.

See 4.3.2303 for the application assertion.

4.2.343.5 language_code

The language_code specifies a language spoken by human beings to communicate with each other verbally or in written form. The language symbol given in ISO 639 shall be used.

The language_code need not be specified for a particular Text.

4.2.343.6 mirror_angle

The mirror_angle specifies the angle, measured in a counter-clockwise direction from the text baseline, to an axis about which the text is mirrored. The mirror axis and text baseline intersect at the location of the Text.

NOTE See Figure 20 for an illustration of the mirror angle characteristic of text.

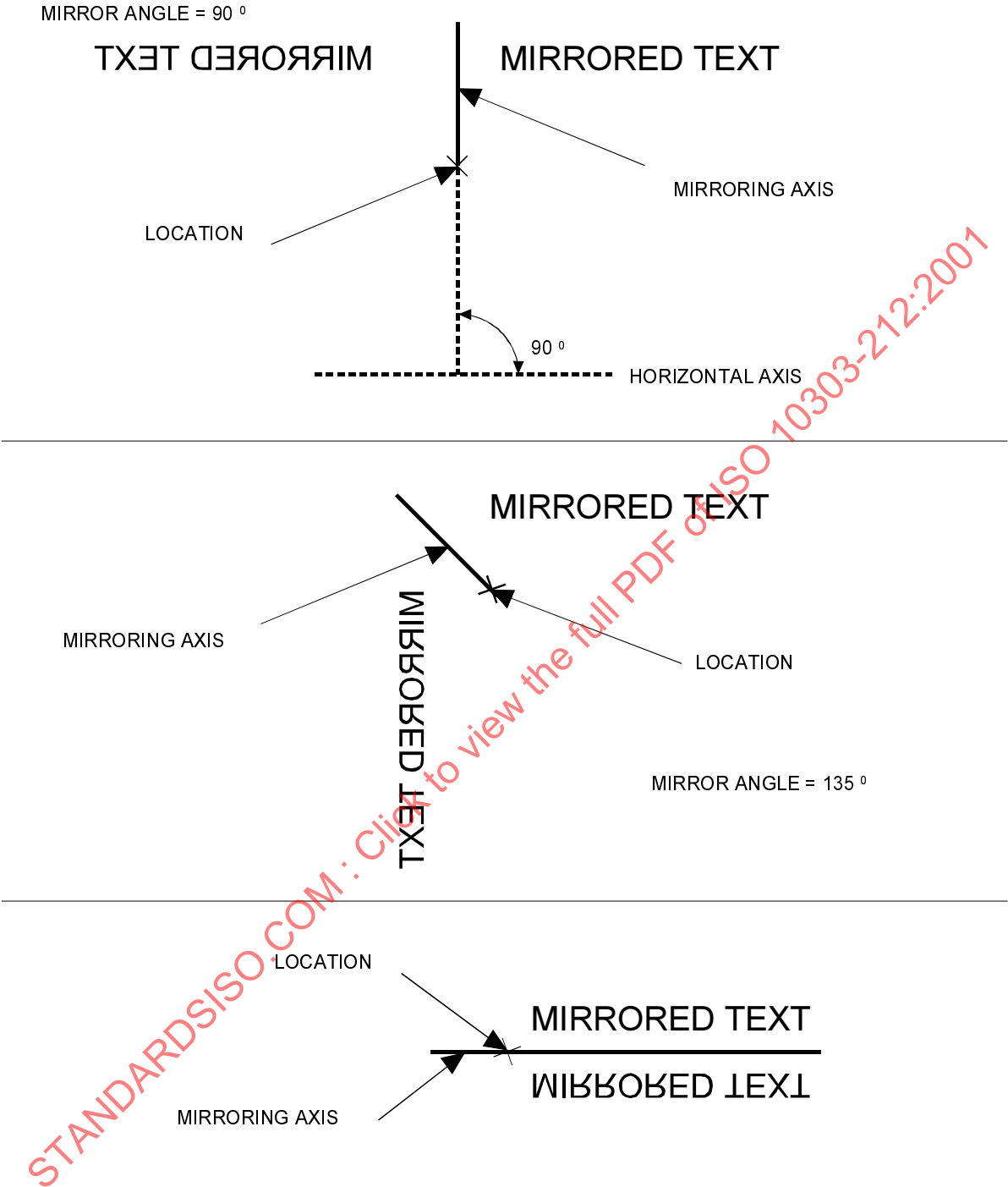

Figure 20 - Mirror angle

The mirror_angle need not be specified for a particular Text.

4.2.343.7 surrounding_box

The surrounding_box specifies the physical space that the text occupies and is defined by width, the distance of the left-most point of the left-most character to the right-most point of the right-most

ISO 10303-212:2001(E)

character measured parallel to the text baseline, and height, the distance of the lowest point of the lowest reaching character to the highest point of the highest reaching character measured perpendicular to the text baseline.

The `surrounding_box` need not be specified for a particular Text.

See 4.3.2302 for the application assertion.

4.2.344 Text_appearance

A `Text_appearance` is a type of `Appearance` (see 4.2.21) that governs the visual presentation of text.

The data associated with `Text_appearance` are the following:

- `character_aspect_ratio`;
- `character_rotation_angle`;
- `character_scale`;
- `character_slant_angle`;
- `font`;
- `text_colour`.

NOTE See Figure 21 for an illustration of the characteristics of text appearance.

4.2.344.1 character_aspect_ratio

The `character_aspect_ratio` specifies the ratio of the width of the character to the height of the character.

4.2.344.2 character_rotation_angle

The `character_rotation_angle` specifies the angular counter-clockwise rotation of each character within the text string in which it appears. The point of rotation is the left-most point of each character at its baseline.

4.2.344.3 character_scale

The `character_scale` specifies the ratio of the size of the text character as defined to the size of the text character as presented.

4.2.344.4 character_slant_angle

The `character_slant_angle` specifies the angular distance between vertical aspects of the individual character and an axis perpendicular to the baseline of the character, measured clockwise.

4.2.344.5 font

The font specifies the actual font that is used for the presentation of the text.

See 4.3.2305 for the application assertion.

4.2.344.6 text_colour

The text_colour specifies the actual colour that is used for the presentation of the text.

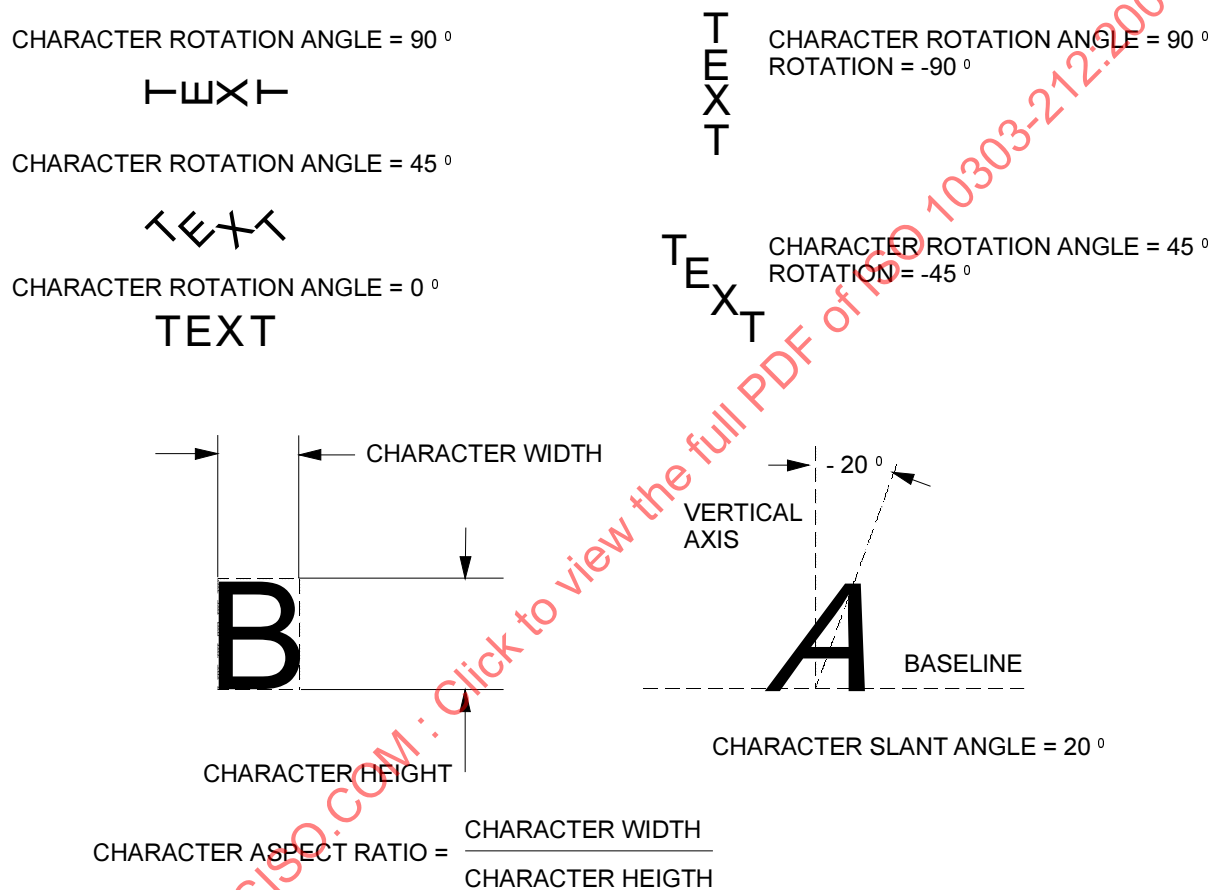

Figure 21 - Text appearance and rotation of text

See 4.3.2304 for the application assertion.

4.2.345 Text_font

A Text_font is the explicit physical description of each individual character of a character set, including its form and spatial characteristics.

Each Text_font is either an Externally_defined_text_font (see 4.2.136) or a Predefined_text_font (see 4.2.256).

4.2.346 Text_string

A Text_string is the smallest unit of text and is a collection of one or more characters that convey some human-interpretable information.

The data associated with a Text_string are the following:

- assigned_appearance;
- character_alignment;
- character_string;
- containing_text;
- overline_underline;
- position;
- rotation;
- surrounding_box.

4.2.346.1 assigned_appearance

The assigned_appearance specifies the outlook of the Text_string object.

The assigned_appearance need not be specified for a particular Text_string.

See 4.3.2309 for the application assertion.

4.2.346.2 character_alignment

The character_alignment specifies the relative position of successive characters in a string of text.

The value of character_alignment is one of the following:

- down;
- left;
- right;
- up.

NOTE See 4.2.346.2.1 - 4.2.346.2.4 for the definition of each permissible value for character_alignment.

4.2.346.2.1 down

down: The presentation of the character is aligned to the bottom line of character body.

4.2.346.2.2 left

left: The presentation of the character is aligned to the left side of the character body.

4.2.346.2.3 right

right: The presentation of the character is aligned to the right side of the character body.

4.2.346.2.4 up

up: The presentation of the character is aligned to the top of the character body.

4.2.346.3 character_string

The `character_string` specifies the list of characters that compose the `Text_string`.

4.2.346.4 containing_text

The `containing_text` specifies the `Text` (see 4.2.342) object containing the `Text_string`.

See 4.3.2308 for the application assertion.

4.2.346.5 overline_underline

The `overline_underline` specifies that there is a line placed either above or beneath the `Text_string`.

The value of `overline_underline` is one of the following:

- `overline`;
- `underline`.

NOTE See 4.2.346.5.1 - 4.2.346.5.2 for the definition of each permissible value for `overline_` - `underline`.

4.2.346.5.1 overline

`overline`: The line is placed above the `Text_string`.

4.2.346.5.2 underline

`underline`: The line is placed beneath the `Text_string`.

The `overline_underline` need not be specified for a particular `Text_string`.

4.2.346.6 position

The `position` specifies the location of the `Text_string` in the placement coordinate system.

See 4.3.2306 for the application assertion.

4.2.346.7 rotation

The rotation specifies the angle, measured counter-clockwise, between the baseline of the text and the horizontal axis of the coordinate system into which it is being placed.

4.2.346.8 surrounding_box

The surrounding_box specifies the physical space that the text string occupies and is defined by width, the distance of the left-most point of the left-most character to the right-most point of the right-most character measured parallel to the text baseline, and height, the distance of the lowest point of the lowest reaching character to the highest point of the highest reaching character measured perpendicular to the text baseline.

See 4.3.2307 for the application assertion.

4.2.347 Tile

A Tile is a graphical symbol defined within a containment border and used as the content of a tiling pattern. The containment border defines the edges of the tile. All elements contained within the border are duplicated for each tile. Tiles are placed within a fill area adjacently and do not overlap. The containment border may be blanked.

Each Tile is either an Externally_defined_tile (see 4.2.137) or a User_defined_tile (see 4.2.356).

The data associated with a Tile are the following:

— overriding_colour.

4.2.347.1 overriding_colour

The overriding_colour specifies the colour definition that overrides the appearance characteristics already assigned to the elements of the tile.

The overriding_colour need not be specified for a particular Tile.

See 4.3.2310 for the application assertion.

4.2.348 Typical_schematic_node

A Typical_schematic_node is a template for all information that is common to all Schematic_node (see 4.2.294) objects that use the Typical_schematic_node as definition.

The data associated with a `Typical_schematic_node` are the following:

- `consists_of`;
- `coordinate_space`;
- `id`;
- `node_area`.

4.2.348.1 `consists_of`

The `consists_of` specifies the constituents of a `Typical_schematic_node` object.

Each `consists_of` may be one of the following: `Annotation_curve` (see 4.2.14), `Fill_area` (see 4.2.139), or `Text` (see 4.2.342).

See 4.3.2311, 4.3.2314, and 4.3.2315 for the application assertions.

4.2.348.2 `coordinate_space`

The `coordinate_space` specifies the coordinate system that describes the two-dimensional space in which the content of the `Typical_schematic_node` is located.

See 4.3.2312 for the application assertion.

4.2.348.3 `id`

The `id` specifies the identifier of the `Typical_schematic_node`.

4.2.348.4 `node_area`

The `node_area` specifies the zone where the schematic terminal is allowed to be connected with other terminals or connecting lines.

EXAMPLE The zone addressed as 'hot spot' of a connect node.

See 4.3.2313 for the application assertion.

4.2.349 `Typical_schematic_text`

A `Typical_schematic_text` is a template for `Schematic_text` (see 4.2.295).

The data associated with a `Typical_schematic_text` are the following:

- `consists_of`;
- `id`.

4.2.349.1 `consists_of`

The `consists_of` specifies the constituents of a `Typical_schematic_text` object.

ISO 10303-212:2001(E)

See 4.3.2316 for the application assertion.

4.2.349.2 id

The id specifies the identifier of the Typical_schematic_text.

4.2.350 Unstructured_dimension_callout

An Unstructured_dimension_callout is a type of Dimension_callout (see 4.2.94) that is a callout wherein a single draughting callout is used and the components of the dimension callout are not semantically identified.

The data associated with an Unstructured_dimension_callout are the following:

- basis_callout.

4.2.350.1 basis_callout

The basis_callout specifies the callout that is identified as being unstructured.

See 4.3.2317 for the application assertion.

4.2.351 User_defined_colour

A User_defined_colour is a type of Colour (see 4.2.50) that is defined by an explicit listing of the proportions of blue, green, and red.

The data associated with a User_defined_colour are the following:

- blue_proportion;
- colour_id;
- green_proportion;
- red_proportion.

4.2.351.1 blue_proportion

The blue_proportion specifies the level of intensity of the colour blue to be displayed.

4.2.351.2 colour_id

The colour_id specifies the identification of a particular user defined colour.

The colour_id need not be specified for a particular User_defined_colour.

4.2.351.3 green_proportion

The green_proportion specifies the level of intensity of the colour green to be displayed.

4.2.351.4 red_proportion

The red_proportion specifies the level of intensity of the colour red to be displayed.

4.2.352 User_defined_data_element

The User_defined_data_element is a type of Data_element (see 4.2.70) that is defined in a user specific standard.

NOTE 1 In many cases User_defined_data_element objects are subject of bilateral arrangements among the exchanging enterprises.

NOTE 2 User_defined_data_element objects may be composed from other Data_element (see 4.2.70) objects by using Data_element_relationship (see 4.2.74) objects with relation_type 'decomposition'.

EXAMPLE 1 A User_defined_data_element object 'Electrical data' comprises all aspects of a drive that are related to the electrical properties of the motor, such as rated voltage, peak voltage, etc.

EXAMPLE 2 A User_defined_data_element object 'Required computer equipment' comprises the data that characterise the hardware and software items needed to run a motor, including the control program, the operating system, type of processor, required capacity of the disk, etc.

The data associated with an User_defined_data_element are the following:

- definition;
- value_of_data_element.

4.2.352.1 definition

The definition specifies a Data_element_definition (see 4.2.72) object that specifies the meaning of the associated values.

See 4.3.2318 for the application assertion.

4.2.352.2 value_of_data_element

The value_of_data_element assigns the Data_element_value (see 4.2.76) to the User_defined_data_element.

The value_of_data_element need not be specified for a particular User_defined_data_element.

See 4.3.2319 for the application assertion.

4.2.353 User_defined_hatching

A User_defined_hatching is a type of Fill_area_appearance (see 4.2.140) that is defined by an explicit listing of hatch patterns.

ISO 10303-212:2001(E)

The data associated with an `User_defined_hatching` are the following:

- `defining_pattern`.

4.2.353.1 `defining_pattern`

The `defining_pattern` specifies the pattern that serves as the template from which the `User_defined_hatching` is derived.

See 4.3.2320 for the application assertion.

4.2.354 `User_defined_line_font`

A `User_defined_line_font` is a type of `Line_font` (see 4.2.189) that is defined by an explicit listing of the visible and invisible segments that make up the pattern of the font.

The data associated with a `User_defined_line_font` are the following:

- `font_id`;
- `pattern`.

4.2.354.1 `font_id`

The `font_id` specifies the identification of a particular line font.

4.2.354.2 `pattern`

The `pattern` specifies a list of length values of visible and invisible segments.

There shall be two or more `pattern` for a `User_defined_line_font`.

4.2.355 `User_defined_symbol`

A `User_defined_symbol` is a type of `Annotation_symbol` (see 4.2.20) that is a symbol that is defined by an explicit listing of annotation elements that make up the symbol along with their positions within the coordinate system in which the symbol is defined.

The data associated with a `User_defined_symbol` are the following:

- `definition`.

4.2.355.1 `definition`

The `definition` specifies the `User_defined_symbol_definition` (see 4.2.355) object that serves as a template for the `User_defined_symbol`.

See 4.3.2321 for the application assertion.

4.2.356 User_defined_symbol_definition

A `User_defined_symbol_definition` is a collection of annotation elements, along with their placements in a coordinate space, that, taken as a whole, represent a distinct concept.

Each `User_defined_symbol_definition` is either a `Drawing_sheet_layout` (see 4.2.123) or a `Reference_grid_layout` (see 4.2.284).

The data associated with an `User_defined_symbol_definition` are the following:

- `blanking_box`;
- `components`;
- `coordinate_space`;
- `symbol_definition_id`.

4.2.356.1 blanking_box

The `blanking_box` specifies an area that the symbol occupies and is used to suppress the visual presentation of all other elements that are within this area.

The `blanking_box` need not be specified for a particular `User_defined_symbol_definition`.

See 4.3.2324 for the application assertion.

4.2.356.2 components

The `components` specifies the constituents of a `User_defined_symbol_definition`.

See 4.3.2322 for the application assertion.

4.2.356.3 coordinate_space

The `coordinate_space` specifies the coordinate system that describes the two-dimensional space in which the constituents of the `User_defined_symbol_definition` are located. The origin of the associated coordinate system is the reference point of the `User_defined_symbol_definition`.

See 4.3.2323 for the application assertion.

4.2.356.4 symbol_definition_id

The `symbol_definition_id` specifies the identification of a particular symbol.

4.2.357 User_defined_tile

A `User_defined_tile` is a type of `Tile` (see 4.2.346) that is defined by an explicit listing of components that make up the tile.

ISO 10303-212:2001(E)

The data associated with an `User_defined_tile` are the following:

- `definition`.

4.2.357.1 `definition`

The `definition` specifies the `User_defined_symbol_definition` (see 4.2.355) object that serves as a template from which the `User_defined_tile` is derived.

See 4.3.2325 for the application assertion.

4.2.358 `User_defined_tiling`

A `User_defined_tiling` is a type of `Fill_area_appearance` (see 4.2.140) that is defined by an explicit listing of tiles.

The data associated with a `User_defined_tiling` are the following:

- `angle`;
- `defining_tile`;
- `repeat_vector_1`;
- `repeat_vector_2`;
- `scale`.

4.2.358.1 `angle`

The `angle` specifies the rotation of the tile, measured counter-clockwise, relative to the x-axis of the coordinate system in which the boundary of the fill area is defined.

4.2.358.2 `defining_tile`

The `defining_tile` specifies the tile that serves as a template from which the `User_defined_tiling` is derived.

See 4.3.2326 for the application assertion.

4.2.358.3 `repeat_vector_1`

The `repeat_vector_1` specifies the direction and the distance in that direction at which to place the tile relative to the placement of a previous tile.

4.2.358.4 `repeat_vector_2`

The `repeat_vector_2` specifies the secondary direction and the distance in that direction at which to place the tile relative to the placement of a previous tile.

4.2.358.5 scale

The scale specifies the ratio between the size of the tile as defined and the size of the tile as presented.

4.2.359 Value_limit

A Value_limit is a type of Value_with_unit (see 4.2.360) that is a qualified numerical value representing either the lower limit or the upper limit of a particular physical characteristic.

EXAMPLE '30.5 max' and '5 min' are examples for a Value_limit.

The data associated with a Value_limit are the following:

- limit;
- limit_qualifier.

4.2.359.1 limit

The limit specifies the value of the limit.

4.2.359.2 limit_qualifier

The limit_qualifier specifies the kind of limit.

The following values shall be used:

- maximum;
- minimum.

NOTE See 4.2.359.2.1 - 4.2.359.2.2 for the definition of each predefined value for limit_qualifier.

4.2.359.2.1 maximum

maximum: The specified limit is an upper limit.

4.2.359.2.2 minimum

minimum: The specified limit is a lower limit.

4.2.360 Value_range

A Value_range is a type of Value_with_unit (see 4.2.360) that is a pair of numerical values representing the range in which the value shall lie.

ISO 10303-212:2001(E)

The data associated with a Value_range are the following:

- lower_limit;
- upper_limit.

4.2.360.1 lower_limit

The lower_limit specifies the minimum acceptable value that is constrained by the Value_range.

4.2.360.2 upper_limit

The upper_limit specifies the maximum acceptable value that is constrained by the Value_range.

4.2.361 Value_with_unit

A Value_with_unit is a single numerical measure, or a range of numerical measures with upper, lower, or upper and lower bounds.

Each Value_with_unit is either a Numerical_value (see 4.2.216), a Value_limit (see 4.2.358), or a Value_range (see 4.2.359).

The data associated with a Value_with_unit are the following:

- significant_digits;
- unit_component.

4.2.361.1 significant_digits

The significant_digits specifies the number of decimal digits that are relevant for the use of the Value_with_unit. If present, the numerical measure or range may be specified using more digits than the significant digits but shall not be specified using less digits.

The significant_digits need not be specified for a particular Value_with_unit.

4.2.361.2 unit_component

The unit_component specifies the unit in which the Value_with_unit is expressed.

The unit_component need not be specified for a particular Value_with_unit.

4.2.362 View_displayed_model

A View_displayed_model is the identification and assignment of appearance characteristics to a Draughting_model (see 4.2.118) when it is presented in a Drawing_view (see 4.2.125).

The data associated with a `View_displayed_model` are the following:

- `clipping`;
- `displayed_model`;
- `overriding_appearance`;
- `presented_in`;
- `scale`;
- `transformation`.

4.2.362.1 clipping

The `clipping` specifies the mathematical information necessary to define a two-dimensional boundary that encloses all viewable geometric and annotation elements of a `Draughting_model` (see 4.2.118). Only those elements, or portions of any elements, that fall within this boundary will be displayed.

See 4.3.2330 for the application assertion.

4.2.362.2 displayed_model

The `displayed_model` specifies the `Draughting_model` (see 4.2.118) that is presented in the `Drawing_view` (see 4.2.125).

See 4.3.2328 for the application assertion.

4.2.362.3 overriding_appearance

The `overriding_appearance` specifies the appearance characteristics that are applied to the `Draughting_model` (see 4.2.118) when presented in the `Drawing_view` (see 4.2.125).

The `overriding_appearance` need not be specified for a particular `View_displayed_model`.

See 4.3.2327 for the application assertion.

4.2.362.4 presented_in

The `presented_in` specifies the `Drawing_view` (see 4.2.125) in which the model will be presented.

See 4.3.2329 for the application assertion.

4.2.362.5 scale

The `scale` specifies the ratio between the size of the elements as defined in the `Draughting_model` (see 4.2.118) and the size of the elements as presented in the `Drawing_view` (see 4.2.125).

4.2.362.6 transformation

The transformation specifies the mathematical values that define the relationship between elements located in the coordinate system of the Draughting_model (see 4.2.118) and their location in the coordinate system of the Drawing_view (see 4.2.125).

4.2.363 View_placed_annotation

A View_placed_annotation is a type of Draughting_annotation (see 4.2.116) that is an annotation that is located in the coordinate system of the drawing view.

The data associated with a View_placed_annotation are the following:

- annotation_layers;
- annotation_visibility;
- containing_view.

4.2.363.1 annotation_layers

The annotation_layers specifies the layers that contain the annotation.

See 4.3.2332 for the application assertion.

4.2.363.2 annotation_visibility

The annotation_visibility specifies whether or not each piece of annotation placed within the drawing sheet is visible.

See 4.3.2333 for the application assertion.

4.2.363.3 containing_view

The containing_sheet specifies the drawing_view in which the View_placed_annotation is placed.

See 4.3.2331 for the application assertion.

4.2.364 Visibility

A Visibility is an indication of whether or not an individual element or collection of elements are displayed in the visual presentation of the drawing. Visibility takes precedence over all other appearance characteristics assigned to the element.

EXAMPLE A construction line is an element not meant for display on a drawing; therefore, visibility would indicate this.

4.2.365 Work_order

A Work_order is the authorization for an Activity (see 4.2.1) to be performed.

The data associated with Work_order are the following:

- description;
- id;
- is_controlling
- version_id;
- work_order_type.

4.2.365.1 description

The description specifies an alphanumeric string containing human-interpretable text that gives further details about the Work_order.

The description need not be specified for a particular Work_order.

4.2.365.2 id

The id specifies the identifier of the Work_order.

4.2.365.3 is_controlling

The is_controlling specifies the Activity (see 4.2.1) that is controlled by this particular Work_order.

See 4.3.2334 for the application assertion.

4.2.365.4 version_id

The version_id specifies versioning information for the Work_order.

The version_id need not be specified for a particular Work_order.

4.2.365.5 work_order_type

The work_order_type specifies the kind of the Work_order. The value is either user defined or predefined.

ISO 10303-212:2001(E)

The predefined value of `work_order_type` is one of the following:

- design deviation permit;
- design release;
- management resolution;
- manufacturing release;
- production deviation permit.

NOTE See 4.2.365.5.1 - 4.2.365.5.5 for the definition of each predefined value for `work_order_type`.

4.2.365.5.1 design deviation permit

design deviation permit: An authorization for a deviation from the approved design data.

4.2.365.5.2 design release

design release: An authorization for the design of a physical or abstract item and for the creation of a bill of material.

4.2.365.5.3 management resolution

management resolution: An authorization by a committee, such as the board of directors, to design or change a product, a product component, or some items.

4.2.365.5.4 manufacturing release

manufacturing release: An authorization for the manufacturing process of a product or an item.

4.2.365.5.5 production deviation permit

production deviation permit: An authorization for a deviation from the approved manufacturing process.

4.2.366 Work_request

A `Work_request` is the solicitation for some type of work to be done.

The data associated with Work_request are the following:

- description;
- id;
- notified_person_or_organization;
- request_type;
- requestor;
- scope;
- status;
- version_id.

4.2.366.1 description

The description specifies an alphanumeric string containing human-interpretable text that gives further details about the Work_request.

The description need not be specified for a particular Work_request.

4.2.366.2 id

The id specifies the identifier of the Work_request.

4.2.366.3 notified_person_or_organization

The notified_person_or_organization specifies the party who shall be informed about the Work_request and the date when the notification occurred.

See 4.3.2357 for the application assertion.

4.2.366.4 request_type

The request_type specifies the intention of the Work_request. The value is either user defined or predefined.

ISO 10303-212:2001(E)

The predefined value of request_type is one of the following:

- change of standard;
- cost reduction;
- customer rejection;
- customer request;
- durability improvement;
- government regulation;
- procurement alignment;
- production alignment;
- production relief;
- production requirement;
- quality improvement;
- security reason;
- standardization;
- supplier request;
- technical improvement;
- tool improvement.

NOTE See 4.2.366.4.1 - 4.2.366.4.16 for the definition of each predefined value for request_type.

4.2.366.4.1 change of standard

change of standard: A request to translate a standard change into action.

4.2.366.4.2 cost reduction

cost reduction: A request aiming at the reduction of engineering and manufacturing costs of an item.

4.2.366.4.3 customer rejection

customer rejection: A request resulting from a rejection by a customer.

4.2.366.4.4 customer request

customer request: A request resulting from requests by a customer.

4.2.366.4.5 durability improvement

durability improvement: A request aiming at a longer life time of a part.

4.2.366.4.6 government regulation

government regulation: A request resulting from legal requirements.

4.2.366.4.7 procurement alignment

procurement alignment: A request to adjust the purchasing process of different items.

4.2.366.4.8 production alignment

production alignment: A request to adjust the manufacturing process of different items.

4.2.366.4.9 production relief

production relief: A request aiming at a simpler assembly and production process.

4.2.366.4.10 production requirement

production requirement: A request for an activity necessary from a production point of view.

4.2.366.4.11 quality improvement

quality improvement: A request aiming at an increased quality of an item.

4.2.366.4.12 security reason

security reason: A request for an activity necessary from a security point of view.

4.2.366.4.13 standardization

standardization: A request to unify variants of an item.

4.2.366.4.14 supplier request

supplier request: A request resulting from requests by a supplier.

4.2.366.4.15 technical improvement

technical improvement: A request aiming at the technical improvement of an item.

4.2.366.4.16 tool improvement

tool improvement: A request aiming at a reduction of the wear of tools.

4.2.366.5 requestor

The requestor specifies the Person (see 4.2.237) or Organization (see 4.2.223) who issued the Work_ - request and the date when the Work_request was issued.

The requestor need not be specified for a particular Work_request.

ISO 10303-212:2001(E)

See 4.3.2358 for the application assertion.

4.2.366.6 scope

The scope specifies the items that are affected by the Work_request.

Each scope may be one of the following: Activity_method (see 4.2.3), Activity_relationship (see 4.2.5), Alternate_item_relationship (see 4.2.11), Alternate_item_relationship (see 4.2.11), Assembly_component_relationship (see 4.2.26), Cable_pull_information (see 4.2.33), Class_category_association (see 4.2.40), Class_condition_association (see 4.2.41), Class_inclusion_association (see 4.2.42), Class_specification_association (see 4.2.44), Class_structure_relationship (see 4.2.45), Classification_system (see 4.2.48), Complex_product (see 4.2.51), Complex_product_relationship (see 4.2.52), Composition_relationship (see 4.2.55), Configuration (see 4.2.56), Connectivity_definition (see 4.2.61), Connectivity_definition_relationship (see 4.2.62), Data_element (see 4.2.70), Data_element_association (see 4.2.71), Data_element_definition (see 4.2.72), Data_element_relationship (see 4.2.74), Design_discipline_item_definition (see 4.2.86), Device (see 4.2.88), Device_relationship (see 4.2.89), Document (see 4.2.101), Document_file (see 4.2.106), Document_file_relationship (see 4.2.107), Document_representation (see 4.2.110), Document_version (see 4.2.114), Document_version_relationship (see 4.2.115), Drawing (see 4.2.119), Drawing_sequence (see 4.2.121), Drawing_sheet (see 4.2.122), Drawing_sheet_relationship (see 4.2.124), Function_definition (see 4.2.145), Function_definition_relationship (see 4.2.146), Function_interface (see 4.2.147), Function_unit (see 4.2.148), Function_unit_relationship (see 4.2.149), Function_version (see 4.2.150), Function_version_relationship (see 4.2.151), Functional_connectivity_definition (see 4.2.152), Functional_connectivity_definition_relationship (see 4.2.153), Generic_note (see 4.2.159), Interface (see 4.2.170), Interface_port (see 4.2.171), Interface_terminal (see 4.2.174), Item (see 4.2.178), Item_definition_relationship (see 4.2.179), Item_version (see 4.2.182), Item_version_relationship (see 4.2.183), Location (see 4.2.192), Location_relationship (see 4.2.194), Manufacturing_configuration (see 4.2.198), Marking (see 4.2.199), Node (see 4.2.208), Node_relationship (see 4.2.209), Notification (see 4.2.213), Notification_relationship (see 4.2.214), Path (see 4.2.232), Path_node (see 4.2.233), Path_node_relationship (see 4.2.234), Path_relationship (see 4.2.235), Physical_assembly_relationship (see 4.2.241), Physical_instance (see 4.2.243), Port (see 4.2.247), Process_variable (see 4.2.260), Process_variable_relationship (see 4.2.261), Product_class (see 4.2.263), Product_identification (see 4.2.268), Product_structure_relationship (see 4.2.270), Requirement (see 4.2.285), Route (see 4.2.290), Route_relationship (see 4.2.291), Section (see 4.2.296), Section_end (see 4.2.297), Section_interface (see 4.2.298), Section_interface_relationship (see 4.2.299), Section_relationship (see 4.2.300), Signal (see 4.2.309), Signal_relationship (see 4.2.311), Signal_value (see 4.2.313), Specification (see 4.2.323), Specification_category (see 4.2.324), Specification_expression (see 4.2.326), Specification_inclusion (see 4.2.327), Technical_system (see 4.2.336), Technical_system_relationship (see 4.2.337), or Terminal (see 4.2.338).

See 4.3.2335, 4.3.2336, 4.3.2337, 4.3.2338, 4.3.2339, 4.3.2340, 4.3.2341, 4.3.2342, 4.3.2343, 4.3.2344, 4.3.2345, 4.3.2346, 4.3.2347, 4.3.2348, 4.3.2349, 4.3.2350, 4.3.2351, 4.3.2352, 4.3.2353, 4.3.2354, 4.3.2355, 4.3.2356, 4.3.2359, 4.3.2360, 4.3.2361, 4.3.2362, 4.3.2363, 4.3.2364, 4.3.2365, 4.3.2366, 4.3.2367, 4.3.2368, 4.3.2369, 4.3.2370, 4.3.2371, 4.3.2372, 4.3.2373, 4.3.2374, 4.3.2375, 4.3.2376, 4.3.2377, 4.3.2378, 4.3.2379, 4.3.2380, 4.3.2381, 4.3.2382, 4.3.2383, 4.3.2384, 4.3.2385, 4.3.2386, 4.3.2387, 4.3.2388, 4.3.2389, 4.3.2390, 4.3.2391, 4.3.2392, 4.3.2393, 4.3.2394, 4.3.2395, 4.3.2396, 4.3.2397, 4.3.2398, 4.3.2399, 4.3.2400, 4.3.2401, 4.3.2402, 4.3.2403, 4.3.2404, 4.3.2405, 4.3.2406, 4.3.2407, 4.3.2408, 4.3.2409, 4.3.2410, 4.3.2411, 4.3.2412, 4.3.2413, 4.3.2414, 4.3.2415,

4.3.2416, 4.3.2417, 4.3.2418, 4.3.2419, 4.3.2420, 4.3.2421, 4.3.2422, 4.3.2423, 4.3.2424, 4.3.2425, and 4.3.2426 for the application assertions.

4.2.366.7 status

The status specifies the position of affairs for the Work_request.

EXAMPLE The status information 'ongoing' would be an example of status.

NOTE The values and sequence of status are company specific.

4.2.366.8 version_id

The version_id specifies versioning information for the Work_request.

The version_id need not be specified for a particular Work_request.

4.3 Application assertions

This subclause specifies the application assertions for the Core Data for electrical design and installation application protocol. Application assertions specify the relationships between application objects, the cardinality of the relationships, and the rules required for the integrity and validity of the application objects and UoFs. The application assertions and their definitions are given below.

4.3.1 Activity to Activity_method

Each Activity refers to zero or one Activity_method in the role of chosen_method. Each Activity_method acts as chosen_method for zero, one, or more Activity objects.

4.3.2 Activity to Date_and_person_or_organization

Each Activity refers to zero or one Date_and_person_or_organization in the role of requestor. Each Date_and_person_or_organization acts as requestor for zero, one, or more Activity objects.

4.3.3 Activity to Date_time

Each Activity refers to zero or one Date_time in the role of actual_end_date. Each Date_time acts as actual_end_date for zero, one, or more Activity objects.

4.3.4 Activity to Date_time

Each Activity refers to zero or one Date_time in the role of actual_start_date. Each Date_time acts as actual_start_date for zero, one, or more Activity objects.

4.3.1 Activity to Date_time

Each Activity refers to zero or one Date_time in the role of planned_end_date. Each Date_time acts as planned_end_date for zero, one, or more Activity objects.

4.3.2 Activity to Date_time

Each Activity refers to zero or one Date_time in the role of planned_start_date. Each Date_time acts as planned_start_date for zero, one, or more Activity objects.

4.3.3 Activity to Duration

Each Activity refers to zero or one Duration in the role of planned_end_date. Each Duration acts as planned_end_date for zero, one, or more Activity objects.

4.3.4 Activity to Event_reference

Each Activity refers to zero or one Event_reference in the role of planned_end_date. Each Event_reference acts as planned_end_date for zero, one, or more Activity objects.

4.3.5 Activity to Event_reference

Each Activity refers to zero or one Event_reference in the role of planned_start_date. Each Event_reference acts as planned_start_date for zero, one, or more Activity objects.

4.3.6 Activity to Organization

Each Activity refers to zero, one, or more Organization objects in the role of concerned_organization. Each Organization acts as concerned_organization for zero, one, or more Activity objects.

4.3.7 Activity to Organization

Each Activity refers to zero, one, or more Organization objects in the role of supplying_organization. Each Organization acts as supplying_organization for zero, one, or more Activity objects.

4.3.8 Activity to Work_request

Each Activity refers to zero, one, or more Work_request objects in the role of resolved_request. Each Work_request acts as resolved_request for zero, one, or more Activity objects.

4.3.9 Activity_element to Activity

Each Activity_element refers to exactly one Activity in the role of associated_activity. Each Activity acts as associated_activity for zero, one, or more Activity_element objects.

4.3.10 Activity_element to Activity_method

Each Activity_element refers to exactly one Activity_method in the role of element. Each Activity_method acts as element for zero, one, or more Activity_element objects.

4.3.11 Activity_element to Activity_relationship

Each Activity_element refers to exactly one Activity_relationship in the role of element. Each Activity_relationship acts as element for zero, one, or more Activity_element objects.

4.3.12 Activity_element to Alternate_item_relationship

Each Activity_element refers to exactly one Alternate_item_relationship in the role of element. Each Alternate_item_relationship acts as element for zero, one, or more Activity_element objects.

4.3.13 Activity_element to Alternate_item_relationship

Each Activity_element refers to exactly one Alternate_item_relationship in the role of element. Each Alternate_item_relationship acts as element for zero, one, or more Activity_element objects.

4.3.14 Activity_element to Assembly_component_relationship

Each Activity_element refers to exactly one Assembly_component_relationship in the role of element. Each Assembly_component_relationship acts as element for zero, one, or more Activity_element objects.

4.3.15 Activity_element to Cable_pull_information

Each Activity_element refers to exactly one Cable_pull_information in the role of element. Each Cable_pull_information acts as element for zero, one, or more Activity_element objects.

4.3.16 Activity_element to Class_category_association

Each Activity_element refers to exactly one Class_category_association in the role of element. Each Class_category_association acts as element for zero, one, or more Activity_element objects.

4.3.17 Activity_element to Class_condition_association

Each Activity_element refers to exactly one Class_condition_association in the role of element. Each Class_condition_association acts as element for zero, one, or more Activity_element objects.

4.3.18 Activity_element to Class_inclusion_association

Each Activity_element refers to exactly one Class_inclusion_association in the role of element. Each Class_inclusion_association acts as element for zero, one, or more Activity_element objects.

4.3.19 Activity_element to Class_specification_association

Each Activity_element refers to exactly one Class_specification_association in the role of element. Each Class_specification_association acts as element for zero, one, or more Activity_element objects.

4.3.20 Activity_element to Class_structure_relationship

Each Activity_element refers to exactly one Class_structure_relationship in the role of element. Each Class_structure_relationship acts as element for zero, one, or more Activity_element objects.

4.3.21 Activity_element to Classification_system

Each Activity_element refers to exactly one Classification_system in the role of element. Each Classification_system acts as element for zero, one, or more Activity_element objects.

4.3.22 Activity_element to Complex_product

Each Activity_element refers to exactly one Complex_product in the role of element. Each Complex_product acts as element for zero, one, or more Activity_element objects.

4.3.23 Activity_element to Complex_product_relationship

Each Activity_element refers to exactly one Complex_product_relationship in the role of element. Each Complex_product_relationship acts as element for zero, one, or more Activity_element objects.

4.3.24 Activity_element to Composition_relationship

Each Activity_element refers to exactly one Composition_relationship in the role of element. Each Composition_relationship acts as element for zero, one, or more Activity_element objects.

4.3.25 Activity_element to Configuration

Each Activity_element refers to exactly one Configuration in the role of element. Each Configuration acts as element for zero, one, or more Activity_element objects.

4.3.26 Activity_element to Connectivity_definition

Each Activity_element refers to exactly one Connectivity_definition in the role of element. Each Connectivity_definition acts as element for zero, one, or more Activity_element objects.

4.3.27 Activity_element to Connectivity_definition_relationship

Each Activity_element refers to exactly one Connectivity_definition_relationship in the role of element. Each Connectivity_definition_relationship acts as element for zero, one, or more Activity_element objects.

4.3.28 Activity_element to Data_element

Each Activity_element refers to exactly one Data_element in the role of element. Each Data_element acts as element for zero, one, or more Activity_element objects.

4.3.29 Activity_element to Data_element_association

Each Activity_element refers to exactly one Data_element_association in the role of element. Each Data_element_association acts as element for zero, one, or more Activity_element objects.

4.3.30 Activity_element to Data_element_definition

Each Activity_element refers to exactly one Data_element_definition in the role of element. Each Data_element_definition acts as element for zero, one, or more Activity_element objects.

4.3.31 Activity_element to Data_element_relationship

Each Activity_element refers to exactly one Data_element_relationship in the role of element. Each Data_element_relationship acts as element for zero, one, or more Activity_element objects.

4.3.32 Activity_element to Design_discipline_item_definition

Each Activity_element refers to exactly one Design_discipline_item_definition in the role of element. Each Design_discipline_item_definition acts as element for zero, one, or more Activity_element objects.

4.3.33 Activity_element to Device

Each Activity_element refers to exactly one Device in the role of element. Each Device acts as element for zero, one, or more Activity_element objects.

4.3.34 Activity_element to Device_relationship

Each Activity_element refers to exactly one Device_relationship in the role of element. Each Device_relationship acts as element for zero, one, or more Activity_element objects.

4.3.35 Activity_element to Document

Each Activity_element refers to exactly one Document in the role of element. Each Document acts as element for zero, one, or more Activity_element objects.

4.3.36 Activity_element to Document_file

Each Activity_element refers to exactly one Document_file in the role of element. Each Document_file acts as element for zero, one, or more Activity_element objects.

4.3.37 Activity_element to Document_file_relationship

Each Activity_element refers to exactly one Document_file_relationship in the role of element. Each Document_file_relationship acts as element for zero, one, or more Activity_element objects.

4.3.38 Activity_element to Document_representation

Each Activity_element refers to exactly one Document_representation in the role of element. Each Document_representation acts as element for zero, one, or more Activity_element objects.

4.3.39 Activity_element to Document_version

Each Activity_element refers to exactly one Document_version in the role of element. Each Document_version acts as element for zero, one, or more Activity_element objects.

4.3.40 Activity_element to Document_version_relationship

Each Activity_element refers to exactly one Document_version_relationship in the role of element. Each Document_version_relationship acts as element for zero, one, or more Activity_element objects.

4.3.41 Activity_element to Drawing

Each Activity_element refers to exactly one Drawing in the role of element. Each Drawing acts as element for zero, one, or more Activity_element objects.

4.3.42 Activity_element to Drawing_sequence

Each Activity_element refers to exactly one Drawing_sequence in the role of element. Each Drawing_sequence acts as element for zero, one, or more Activity_element objects.

4.3.43 Activity_element to Drawing_sheet

Each Activity_element refers to exactly one Drawing_sheet in the role of element. Each Drawing_sheet acts as element for zero, one, or more Activity_element objects.

4.3.44 Activity_element to Drawing_sheet_relationship

Each Activity_element refers to exactly one Drawing_sheet_relationship in the role of element. Each Drawing_sheet_relationship acts as element for zero, one, or more Activity_element objects.

4.3.45 Activity_element to Function_definition

Each Activity_element refers to exactly one Function_definition in the role of element. Each Function_definition acts as element for zero, one, or more Activity_element objects.

4.3.46 Activity_element to Function_definition_relationship

Each Activity_element refers to exactly one Function_definition_relationship in the role of element. Each Function_definition_relationship acts as element for zero, one, or more Activity_element objects.

4.3.47 Activity_element to Function_interface

Each Activity_element refers to exactly one Function_interface in the role of element. Each Function_interface acts as element for zero, one, or more Activity_element objects.

4.3.48 Activity_element to Function_unit

Each Activity_element refers to exactly one Function_unit in the role of element. Each Function_unit acts as element for zero, one, or more Activity_element objects.

4.3.49 Activity_element to Function_unit_relationship

Each Activity_element refers to exactly one Function_unit_relationship in the role of element. Each Function_unit_relationship acts as element for zero, one, or more Activity_element objects.

4.3.50 Activity_element to Function_version

Each Activity_element refers to exactly one Function_version in the role of element. Each Function_version acts as element for zero, one, or more Activity_element objects.

4.3.51 Activity_element to Function_version_relationship

Each Activity_element refers to exactly one Function_version_relationship in the role of element. Each Function_version_relationship acts as element for zero, one, or more Activity_element objects.

4.3.52 Activity_element to Functional_connectivity_definition

Each Activity_element refers to exactly one Functional_connectivity_definition in the role of element. Each Functional_connectivity_definition acts as element for zero, one, or more Activity_element objects.

4.3.53 Activity_element to Functional_connectivity_definition_relationship

Each Activity_element refers to exactly one Functional_connectivity_definition_relationship in the role of element. Each Functional_connectivity_definition_relationship acts as element for zero, one, or more Activity_element objects.

4.3.54 Activity_element to Generic_note

Each Activity_element refers to exactly one Generic_note in the role of element. Each Generic_note acts as element for zero, one, or more Activity_element objects.

4.3.55 Activity_element to Interface

Each Activity_element refers to exactly one Interface in the role of element. Each Interface acts as element for zero, one, or more Activity_element objects.

4.3.56 Activity_element to Interface_port

Each Activity_element refers to exactly one Interface_port in the role of element. Each Interface_port acts as element for zero, one, or more Activity_element objects.

4.3.57 Activity_element to Interface_terminal

Each Activity_element refers to exactly one Interface_terminal in the role of element. Each Interface_terminal acts as element for zero, one, or more Activity_element objects.

4.3.58 Activity_element to Item

Each Activity_element refers to exactly one Item in the role of element. Each Item acts as element for zero, one, or more Activity_element objects.

4.3.59 Activity_element to Item_definition_relationship

Each Activity_element refers to exactly one Item_definition_relationship in the role of element. Each Item_definition_relationship acts as element for zero, one, or more Activity_element objects.

4.3.60 Activity_element to Item_version

Each Activity_element refers to exactly one Item_version in the role of element. Each Item_version acts as element for zero, one, or more Activity_element objects.

4.3.61 Activity_element to Item_version_relationship

Each Activity_element refers to exactly one Item_version_relationship in the role of element. Each Item_version_relationship acts as element for zero, one, or more Activity_element objects.

4.3.62 Activity_element to Location

Each Activity_element refers to exactly one Location in the role of element. Each Location acts as element for zero, one, or more Activity_element objects.

4.3.63 Activity_element to Location_relationship

Each Activity_element refers to exactly one Location_relationship in the role of element. Each Location_relationship acts as element for zero, one, or more Activity_element objects.

4.3.64 Activity_element to Manufacturing_configuration

Each Activity_element refers to exactly one Manufacturing_configuration in the role of element. Each Manufacturing_configuration acts as element for zero, one, or more Activity_element objects.

4.3.65 Activity_element to Marking

Each Activity_element refers to exactly one Marking in the role of element. Each Marking acts as element for zero, one, or more Activity_element objects.

4.3.66 Activity_element to Node

Each Activity_element refers to exactly one Node in the role of element. Each Node acts as element for zero, one, or more Activity_element objects.

4.3.67 Activity_element to Node_relationship

Each Activity_element refers to exactly one Node_relationship in the role of element. Each Node_relationship acts as element for zero, one, or more Activity_element objects.

4.3.68 Activity_element to Notification

Each Activity_element refers to exactly one Notification in the role of element. Each Notification acts as element for zero, one, or more Activity_element objects.

4.3.69 Activity_element to Notification_relationship

Each Activity_element refers to exactly one Notification_relationship in the role of element. Each Notification_relationship acts as element for zero, one, or more Activity_element objects.

4.3.70 Activity_element to Path

Each Activity_element refers to exactly one Path in the role of element. Each Path acts as element for zero, one, or more Activity_element objects.

4.3.71 Activity_element to Path_node

Each Activity_element refers to exactly one Path_node in the role of element. Each Path_node acts as element for zero, one, or more Activity_element objects.

4.3.72 Activity_element to Path_node_relationship

Each Activity_element refers to exactly one Path_node_relationship in the role of element. Each Path_node_relationship acts as element for zero, one, or more Activity_element objects.

4.3.73 Activity_element to Path_relationship

Each Activity_element refers to exactly one Path_relationship in the role of element. Each Path_relationship acts as element for zero, one, or more Activity_element objects.

4.3.74 Activity_element to Physical_assembly_relationship

Each Activity_element refers to exactly one Physical_assembly_relationship in the role of element. Each Physical_assembly_relationship acts as element for zero, one, or more Activity_element objects.

4.3.75 Activity_element to Physical_instance

Each Activity_element refers to exactly one Physical_instance in the role of element. Each Physical_instance acts as element for zero, one, or more Activity_element objects.

4.3.76 Activity_element to Port

Each Activity_element refers to exactly one Port in the role of element. Each Port acts as element for zero, one, or more Activity_element objects.

4.3.77 Activity_element to Process_variable

Each Activity_element refers to exactly one Process_variable in the role of element. Each Process_variable acts as element for zero, one, or more Activity_element objects.

4.3.78 Activity_element to Process_variable_relationship

Each Activity_element refers to exactly one Process_variable_relationship in the role of element. Each Process_variable_relationship acts as element for zero, one, or more Activity_element objects.

4.3.79 Activity_element to Product_class

Each Activity_element refers to exactly one Product_class in the role of element. Each Product_class acts as element for zero, one, or more Activity_element objects.

4.3.80 Activity_element to Product_identification

Each Activity_element refers to exactly one Product_identification in the role of element. Each Product_identification acts as element for zero, one, or more Activity_element objects.

4.3.81 Activity_element to Product_structure_relationship

Each Activity_element refers to exactly one Product_structure_relationship in the role of element. Each Product_structure_relationship acts as element for zero, one, or more Activity_element objects.

4.3.82 Activity_element to Requirement

Each Activity_element refers to exactly one Requirement in the role of element. Each Requirement acts as element for zero, one, or more Activity_element objects.

4.3.83 Activity_element to Route

Each Activity_element refers to exactly one Route in the role of element. Each Route acts as element for zero, one, or more Activity_element objects.

4.3.84 Activity_element to Route_relationship

Each Activity_element refers to exactly one Route_relationship in the role of element. Each Route_relationship acts as element for zero, one, or more Activity_element objects.

4.3.85 Activity_element to Section

Each Activity_element refers to exactly one Section in the role of element. Each Section acts as element for zero, one, or more Activity_element objects.

4.3.86 Activity_element to Section_end

Each Activity_element refers to exactly one Section_end in the role of element. Each Section_end acts as element for zero, one, or more Activity_element objects.

4.3.87 Activity_element to Section_interface

Each Activity_element refers to exactly one Section_interface in the role of element. Each Section_interface acts as element for zero, one, or more Activity_element objects.

4.3.88 Activity_element to Section_interface_relationship

Each Activity_element refers to exactly one Section_interface_relationship in the role of element. Each Section_interface_relationship acts as element for zero, one, or more Activity_element objects.

4.3.89 Activity_element to Section_relationship

Each Activity_element refers to exactly one Section_relationship in the role of element. Each Section_relationship acts as element for zero, one, or more Activity_element objects.

4.3.90 Activity_element to Signal

Each Activity_element refers to exactly one Signal in the role of element. Each Signal acts as element for zero, one, or more Activity_element objects.

4.3.91 Activity_element to Signal_relationship

Each Activity_element refers to exactly one Signal_relationship in the role of element. Each Signal_relationship acts as element for zero, one, or more Activity_element objects.

4.3.92 Activity_element to Signal_value

Each Activity_element refers to exactly one Signal_value in the role of element. Each Signal_value acts as element for zero, one, or more Activity_element objects.

4.3.93 Activity_element to Specification

Each Activity_element refers to exactly one Specification in the role of element. Each Specification acts as element for zero, one, or more Activity_element objects.

4.3.94 Activity_element to Specification_category

Each Activity_element refers to exactly one Specification_category in the role of element. Each Specification_category acts as element for zero, one, or more Activity_element objects.

4.3.95 Activity_element to Specification_expression

Each Activity_element refers to exactly one Specification_expression in the role of element. Each Specification_expression acts as element for zero, one, or more Activity_element objects.

4.3.96 Activity_element to Specification_inclusion

Each Activity_element refers to exactly one Specification_inclusion in the role of element. Each Specification_inclusion acts as element for zero, one, or more Activity_element objects.

4.3.97 Activity_element to Technical_system

Each Activity_element refers to exactly one Technical_system in the role of element. Each Technical_system acts as element for zero, one, or more Activity_element objects.

4.3.98 Activity_element to Technical_system_relationship

Each Activity_element refers to exactly one Technical_system_relationship in the role of element. Each Technical_system_relationship acts as element for zero, one, or more Activity_element objects.

4.3.99 Activity_element to Terminal

Each Activity_element refers to exactly one Terminal in the role of element. Each Terminal acts as element for zero, one, or more Activity_element objects.

4.3.100 Activity_method_assignment to Activity_method

Each Activity_method_assignment refers to exactly one Activity_method in the role of assigned_method. Each Activity_method acts as assigned_method for zero, one, or more Activity_method_assignment objects.

4.3.101 Activity_method_assignment to Work_request

Each Activity_method_assignment refers to exactly one Work_request in the role of assigned_work_request. Each Work_request acts as assigned_work_request for zero, one, or more Activity_method_assignment objects.

4.3.102 Activity_relationship to Activity

Each Activity_relationship refers to exactly one Activity in the role of related. Each Activity acts as related for zero, one, or more Activity_relationship objects.

4.3.103 Activity_relationship to Activity

Each Activity_relationship refers to exactly one Activity in the role of relating. Each Activity acts as relating for zero, one, or more Activity_relationship objects.

4.3.104 Aggregated_value to Data_element_value

Each Aggregated_value refers to one or more Data_element_value objects in the role of member_definition. Each Data_element_value acts as member_definition for zero, one, or more Aggregated_value objects.

4.3.105 Alias_designation to Device

Each Alias_designation is_applied_to exactly one Device. Each Device is related to zero, one, or more Alias_designation objects.

4.3.106 Alias_designation to Document_representation

Each Alias_designation is_applied_to exactly one Document_representation. Each Document_representation is related to zero, one, or more Alias_designation objects.

4.3.107 Alias_designation to Drawing

Each Alias_designation is_applied_to exactly one Drawing. Each Drawing is related to zero, one, or more Alias_designation objects.

4.3.108 Alias_designation to Drawing_sheet

Each Alias_designation is_applied_to exactly one Drawing_sheet. Each Drawing_sheet is related to zero, one, or more Alias_designation objects.

4.3.109 Alias_designation to Function_unit

Each Alias_designation is_applied_to exactly one Function_unit. Each Function_unit is related to zero, one, or more Alias_designation objects.

4.3.110 Alias_designation to Location

Each Alias_designation is_applied_to exactly one Location. Each Location is related to zero, one, or more Alias_designation objects.

4.3.111 Alias_designation to Object_designation

Each Alias_designation refers to exactly one Object_designation in the role of alias_extended_designation. Each Object_designation acts as alias_extended_designation for zero, one, or more Alias_designation objects.

4.3.112 Alias_designation to Organization

Each Alias_designation refers to zero or one Organization in the role of alias_scope. Each Organization acts as alias_scope for zero, one, or more Alias_designation objects.

4.3.113 Alias_designation to Port

Each Alias_designation is_applied_to exactly one Port. Each Port is related to zero, one, or more Alias_designation objects.

4.3.114 Alias_designation to Product_component

Each Alias_designation is_applied_to exactly one Product_component. Each Product_component is related to zero, one, or more Alias_designation objects.

4.3.115 Alias_designation to Signal

Each Alias_designation is_applied_to exactly one Signal. Each Signal is related to zero, one, or more Alias_designation objects.

4.3.116 Alias_designation to Technical_system

Each Alias_designation is_applied_to exactly one Technical_system. Each Technical_system is related to zero, one, or more Alias_designation objects.

4.3.117 Alias_designation to Terminal

Each Alias_designation is_applied_to exactly one Terminal. Each Terminal is related to zero, one, or more Alias_designation objects.

4.3.118 Alias_identification to Approval_status

Each Alias_identification is_applied_to exactly one Approval_status. Each Approval_status is related to zero, one, or more Alias_identification objects.

4.3.119 Alias_identification to Classification_attribute

Each Alias_identification is_applied_to exactly one Classification_attribute. Each Classification_attribute is related to zero, one, or more Alias_identification objects.

4.3.120 Alias_identification to Classification_system

Each Alias_identification is_applied_to exactly one Classification_system. Each Classification_system is related to zero, one, or more Alias_identification objects.

4.3.121 Alias_identification to Complex_product

Each Alias_identification is_applied_to exactly one Complex_product. Each Complex_product is related to zero, one, or more Alias_identification objects.

4.3.122 Alias_identification to Component_colour

Each Alias_identification is_applied_to exactly one Component_colour. Each Component_colour is related to zero, one, or more Alias_identification objects.

4.3.123 Alias_identification to Connectivity_definition

Each Alias_identification is_applied_to exactly one Connectivity_definition. Each Connectivity_definition is related to zero, one, or more Alias_identification objects.

4.3.124 Alias_identification to Data_element_definition

Each Alias_identification is_applied_to exactly one Data_element_definition. Each Data_element_definition is related to zero, one, or more Alias_identification objects.

4.3.125 Alias_identification to Design_discipline_item_definition

Each Alias_identification is_applied_to exactly one Design_discipline_item_definition. Each Design_discipline_item_definition is related to zero, one, or more Alias_identification objects.

4.3.126 Alias_identification to Device

Each Alias_identification is_applied_to exactly one Device. Each Device is related to zero, one, or more Alias_identification objects.

4.3.127 Alias_identification to Document

Each Alias_identification is_applied_to exactly one Document. Each Document is related to zero, one, or more Alias_identification objects.

4.3.128 Alias_identification to Document_representation

Each Alias_identification is_applied_to exactly one Document_representation. Each Document_representation is related to zero, one, or more Alias_identification objects.

4.3.129 Alias_identification to Document_type_property

Each Alias_identification is_applied_to exactly one Document_type_property. Each Document_type_property is related to zero, one, or more Alias_identification objects.

4.3.130 Alias_identification to Document_version

Each Alias_identification is_applied_to exactly one Document_version. Each Document_version is related to zero, one, or more Alias_identification objects.

4.3.131 Alias_identification to Drawing

Each Alias_identification is_applied_to exactly one Drawing. Each Drawing is related to zero, one, or more Alias_identification objects.

4.3.132 Alias_identification to Drawing_sheet

Each Alias_identification is_applied_to exactly one Drawing_sheet. Each Drawing_sheet is related to zero, one, or more Alias_identification objects.

4.3.133 Alias_identification to Function_definition

Each Alias_identification is_applied_to exactly one Function_definition. Each Function_definition is related to zero, one, or more Alias_identification objects.

4.3.134 Alias_identification to Function_unit

Each Alias_identification is_applied_to exactly one Function_unit. Each Function_unit is related to zero, one, or more Alias_identification objects.

4.3.135 Alias_identification to Functional_connectivity_definition

Each Alias_identification is_applied_to exactly one Functional_connectivity_definition. Each Functional_connectivity_definition is related to zero, one, or more Alias_identification objects.

4.3.136 Alias_identification to Functionality

Each Alias_identification is_applied_to exactly one Functionality. Each Functionality is related to zero, one, or more Alias_identification objects.

4.3.137 Alias_identification to General_classification

Each Alias_identification is_applied_to exactly one General_classification. Each General_classification is related to zero, one, or more Alias_identification objects.

4.3.138 Alias_identification to Interface_port

Each Alias_identification is_applied_to exactly one Interface_port. Each Interface_port is related to zero, one, or more Alias_identification objects.

4.3.139 Alias_identification to Interface_terminal

Each Alias_identification is_applied_to exactly one Interface_terminal. Each Interface_terminal is related to zero, one, or more Alias_identification objects.

4.3.140 Alias_identification to Item

Each Alias_identification is_applied_to exactly one Item. Each Item is related to zero, one, or more Alias_identification objects.

4.3.141 Alias_identification to Item_version

Each Alias_identification is_applied_to exactly one Item_version. Each Item_version is related to zero, one, or more Alias_identification objects.

4.3.142 Alias_identification to Location

Each Alias_identification is_applied_to exactly one Location. Each Location is related to zero, one, or more Alias_identification objects.

4.3.143 Alias_identification to Node

Each Alias_identification is_applied_to exactly one Node. Each Node is related to zero, one, or more Alias_identification objects.

4.3.144 Alias_identification to Notification

Each Alias_identification is_applied_to exactly one Notification. Each Notification is related to zero, one, or more Alias_identification objects.

4.3.145 Alias_identification to Organization

Each Alias_identification refers to zero or one Organization in the role of alias_scope. Each Organization acts as alias_scope for zero, one, or more Alias_identification objects.

4.3.146 Alias_identification to Organization

Each Alias_identification is_applied_to exactly one Organization. Each Organization is related to zero, one, or more Alias_identification objects.

4.3.147 Alias_identification to Path

Each Alias_identification is_applied_to exactly one Path. Each Path is related to zero, one, or more Alias_identification objects.

4.3.148 Alias_identification to Path_node

Each Alias_identification is_applied_to exactly one Path_node. Each Path_node is related to zero, one, or more Alias_identification objects.

4.3.149 Alias_identification to Physical_instance

Each Alias_identification is_applied_to exactly one Physical_instance. Each Physical_instance is related to zero, one, or more Alias_identification objects.

4.3.150 Alias_identification to Port

Each Alias_identification is_applied_to exactly one Port. Each Port is related to zero, one, or more Alias_identification objects.

4.3.151 Alias_identification to Process_variable

Each Alias_identification is_applied_to exactly one Process_variable. Each Process_variable is related to zero, one, or more Alias_identification objects.

4.3.152 Alias_identification to Product_class

Each Alias_identification is_applied_to exactly one Product_class. Each Product_class is related to zero, one, or more Alias_identification objects.

4.3.153 Alias_identification to Product_identification

Each Alias_identification is_applied_to exactly one Product_identification. Each Product_identification is related to zero, one, or more Alias_identification objects.

4.3.154 Alias_identification to Requirement

Each Alias_identification is_applied_to exactly one Requirement. Each Requirement is related to zero, one, or more Alias_identification objects.

4.3.155 Alias_identification to Route

Each Alias_identification is_applied_to exactly one Route. Each Route is related to zero, one, or more Alias_identification objects.

4.3.156 Alias_identification to Section

Each Alias_identification is_applied_to exactly one Section. Each Section is related to zero, one, or more Alias_identification objects.

4.3.157 Alias_identification to Section_interface

Each Alias_identification is_applied_to exactly one Section_interface. Each Section_interface is related to zero, one, or more Alias_identification objects.

4.3.158 Alias_identification to Security_level

Each Alias_identification is_applied_to exactly one Security_level. Each Security_level is related to zero, one, or more Alias_identification objects.

4.3.159 Alias_identification to Signal

Each Alias_identification is_applied_to exactly one Signal. Each Signal is related to zero, one, or more Alias_identification objects.

4.3.160 Alias_identification to Specification

Each Alias_identification is_applied_to exactly one Specification. Each Specification is related to zero, one, or more Alias_identification objects.

4.3.161 Alias_identification to Specification_category

Each Alias_identification is_applied_to exactly one Specification_category. Each Specification_category is related to zero, one, or more Alias_identification objects.

4.3.162 Alias_identification to Technical_system

Each Alias_identification is_applied_to exactly one Technical_system. Each Technical_system is related to zero, one, or more Alias_identification objects.

4.3.163 Alias_identification to Terminal

Each Alias_identification is_applied_to exactly one Terminal. Each Terminal is related to zero, one, or more Alias_identification objects.

4.3.164 Alias_version to Alias_designation

Each Alias_version refers to exactly one Alias_designation in the role of associated_alias_id. Each Alias_designation acts as associated_alias_id for zero, one, or more Alias_version objects.

4.3.165 Alias_version to Alias_identification

Each Alias_version refers to exactly one Alias_identification in the role of associated_alias_id. Each Alias_identification acts as associated_alias_id for zero, one, or more Alias_version objects.

4.3.166 Alternate_item_relationship to Item

Each Alternate_item_relationship refers to exactly one Item in the role of alternate. Each Item acts as alternate for zero, one, or more Alternate_item_relationship objects.

4.3.167 Alternate_item_relationship to Item

Each Alternate_item_relationship refers to exactly one Item in the role of base. Each Item acts as base for zero, one, or more Alternate_item_relationship objects.

4.3.168 Alternative_solution to Alternative_solution

Each Alternative_solution refers to exactly one Alternative_solution in the role of base_element. Each Alternative_solution acts as base_element for zero, one, or more Alternative_solution objects.

4.3.169 Alternative_solution to Function_definition

Each Alternative_solution refers to exactly one Function_definition in the role of base_element. Each Function_definition acts as base_element for zero, one, or more Alternative_solution objects.

4.3.170 Alternative_solution to Product_component

Each Alternative_solution refers to exactly one Product_component in the role of base_element. Each Product_component acts as base_element for zero, one, or more Alternative_solution objects.

4.3.171 Alternative_solution to Single_function_unit

Each Alternative_solution refers to exactly one Single_function_unit in the role of base_element. Each Single_function_unit acts as base_element for zero, one, or more Alternative_solution objects.

4.3.172 Angular_dimension to Dimension_line

Each Angular_dimension refers to exactly one Dimension_line in the role of extent. Each Dimension_line acts as extent for zero, one, or more Angular_dimension objects.

4.3.173 Angular_dimension to Projection_line

Each Angular_dimension refers to zero, one, or two Projection_line objects in the role of component. Each Projection_line acts as component for zero, one, or more Angular_dimension objects.

4.3.174 Annotation_curve to Curve_appearance

Each Annotation_curve refers to exactly one Curve_appearance in the role of assigned_appearance. Each Curve_appearance acts as assigned_appearance for zero, one, or more Annotation_curve objects.

4.3.175 Annotation_subfigure to Annotation_subfigure_definition

Each Annotation_subfigure refers to exactly one Annotation_subfigure_definition in the role of definition. Each Annotation_subfigure_definition acts as definition for zero, one, or more Annotation_subfigure objects.

4.3.176 Annotation_subfigure to Point_2d

Each Annotation_subfigure refers to exactly one Point_2d in the role of position. Each Point_2d acts as position for zero, one, or more Annotation_subfigure objects.

4.3.177 Annotation_subfigure_definition to Cartesian_coordinate_space_2d

Each Annotation_subfigure_definition refers to exactly one Cartesian_coordinate_space_2d in the role of coordinate_space. Each Cartesian_coordinate_space_2d acts as coordinate_space for zero, one, or more Annotation_subfigure_definition objects.

4.3.178 Annotation_subfigure_definition to Rectangular_area

Each Annotation_subfigure_definition refers to zero or one Rectangular_area in the role of blanking_box. Each Rectangular_area acts as blanking_box for zero, one, or more Annotation_subfigure_definition objects.

4.3.179 Annotation_subfigure_definition_element to Annotation_placed_annotation

Each Annotation_subfigure_definition_element refers to exactly one Annotation_placed_annotation in the role of used_annotation. Each Annotation_placed_annotation acts as used_annotation for zero, one, or more Annotation_subfigure_definition_element objects.

4.3.180 Annotation_subfigure_definition_element to Annotation_subfigure_definition

Each Annotation_subfigure_definition_element refers to exactly one Annotation_subfigure_definition in the role of containing_definition. Each Annotation_subfigure_definition acts as containing_definition for zero, one, or more Annotation_subfigure_definition_element objects.

4.3.181 Annotation_subfigure_definition_element to Layer

Each Annotation_subfigure_definition_element refers to one or more Layer objects in the role of annotation_layers. Each Layer acts as annotation_layers for zero, one, or more Annotation_subfigure_definition_element objects.

4.3.182 Annotation_subfigure_definition_element to Visibility

Each Annotation_subfigure_definition_element refers to exactly one Visibility in the role of annotation_visibility. Each Visibility acts as annotation_visibility for zero, one, or more Annotation_subfigure_definition_element objects.

4.3.183 Annotation_symbol to Colour

Each Annotation_symbol refers to zero or one Colour in the role of overriding_colour. Each Colour acts as overriding_colour for zero, one, or more Annotation_symbol objects.

4.3.184 Annotation_symbol to Point_2d

Each Annotation_symbol refers to exactly one Point_2d in the role of position. Each Point_2d acts as position for zero, one, or more Annotation_symbol objects.

4.3.185 Annotation_symbol to Rectangular_area

Each Annotation_symbol refers to zero or one Rectangular_area in the role of blanking_box. Each Rectangular_area acts as blanking_box for zero, one, or more Annotation_symbol objects.

4.3.186 Approval to Activity

Each Approval is_applied_to one or more Activity objects. Each Activity is related to zero, one, or more Approval objects.

4.3.187 Approval to Activity_element

Each Approval is_applied_to one or more Activity_element objects. Each Activity_element is related to zero, one, or more Approval objects.

4.3.188 Approval to Activity_method_assignment

Each Approval is_applied_to one or more Activity_method_assignment objects. Each Activity_method_assignment is related to zero, one, or more Approval objects.

4.3.189 Approval to Activity_relationship

Each Approval is_applied_to one or more Activity_relationship objects. Each Activity_relationship is related to zero, one, or more Approval objects.

4.3.190 Approval to Alternate_item_relationship

Each Approval is_applied_to one or more Alternate_item_relationship objects. Each Alternate_item_relationship is related to zero, one, or more Approval objects.

4.3.191 Approval to Alternate_item_relationship

Each Approval is_applied_to one or more Alternate_item_relationship objects. Each Alternate_item_relationship is related to zero, one, or more Approval objects.

4.3.192 Approval to Approval_status

Each Approval refers to exactly one Approval_status in the role of status. Each Approval_status acts as status for zero, one, or more Approval objects.

4.3.193 Approval to Assembly_component_relationship

Each Approval is_applied_to one or more Assembly_component_relationship objects. Each Assembly_component_relationship is related to zero, one, or more Approval objects.

4.3.194 Approval to Cable_pull_information

Each Approval is_applied_to one or more Cable_pull_information objects. Each Cable_pull_information is related to zero, one, or more Approval objects.

4.3.195 Approval to Certification

Each Approval is_applied_to one or more Certification objects. Each Certification is related to zero, one, or more Approval objects.

4.3.196 Approval to Class_category_association

Each Approval is_applied_to one or more Class_category_association objects. Each Class_category_association is related to zero, one, or more Approval objects.

4.3.197 Approval to Class_condition_association

Each Approval is_applied_to one or more Class_condition_association objects. Each Class_condition_association is related to zero, one, or more Approval objects.

4.3.198 Approval to Class_inclusion_association

Each Approval is_applied_to one or more Class_inclusion_association objects. Each Class_inclusion_association is related to zero, one, or more Approval objects.

4.3.199 Approval to Class_specification_association

Each Approval is_applied_to one or more Class_specification_association objects. Each Class_specification_association is related to zero, one, or more Approval objects.

4.3.200 Approval to Class_structure_relationship

Each Approval is_applied_to one or more Class_structure_relationship objects. Each Class_structure_relationship is related to zero, one, or more Approval objects.

4.3.201 Approval to Classification_association

Each Approval is_applied_to one or more Classification_association objects. Each Classification_association is related to zero, one, or more Approval objects.

4.3.202 Approval to Classification_system

Each Approval is_applied_to one or more Classification_system objects. Each Classification_system is related to zero, one, or more Approval objects.

4.3.203 Approval to Complex_product

Each Approval is_applied_to one or more Complex_product objects. Each Complex_product is related to zero, one, or more Approval objects.

4.3.204 Approval to Complex_product_relationship

Each Approval is_applied_to one or more Complex_product_relationship objects. Each Complex_product_relationship is related to zero, one, or more Approval objects.

4.3.205 Approval to Composition_relationship

Each Approval is_applied_to one or more Composition_relationship objects. Each Composition_relationship is related to zero, one, or more Approval objects.

4.3.206 Approval to Configuration

Each Approval is_applied_to one or more Configuration objects. Each Configuration is related to zero, one, or more Approval objects.

4.3.207 Approval to Connectivity_allocation

Each Approval is_applied_to one or more Connectivity_allocation objects. Each Connectivity_allocation is related to zero, one, or more Approval objects.

4.3.208 Approval to Connectivity_definition

Each Approval is_applied_to one or more Connectivity_definition objects. Each Connectivity_definition is related to zero, one, or more Approval objects.

4.3.209 Approval to Connectivity_definition_relationship

Each Approval is_applied_to one or more Connectivity_definition_relationship objects. Each Connectivity_definition_relationship is related to zero, one, or more Approval objects.

4.3.210 Approval to Contract

Each Approval is_applied_to one or more Contract objects. Each Contract is related to zero, one, or more Approval objects.

4.3.211 Approval to Data_element

Each Approval is_applied_to one or more Data_element objects. Each Data_element is related to zero, one, or more Approval objects.

4.3.212 Approval to Data_element_association

Each Approval is_applied_to one or more Data_element_association objects. Each Data_element_association is related to zero, one, or more Approval objects.

4.3.213 Approval to Data_element_definition

Each Approval is_applied_to one or more Data_element_definition objects. Each Data_element_definition is related to zero, one, or more Approval objects.

4.3.214 Approval to Data_element_relationship

Each Approval is_applied_to one or more Data_element_relationship objects. Each Data_element_relationship is related to zero, one, or more Approval objects.

4.3.215 Approval to Date_and_person_or_organization

Each Approval is_approved_by zero, one, or more Date_and_person_or_organization objects. Each Date_and_person_or_organization is related to zero, one, or more Approval objects.

4.3.216 Approval to Date_time

Each Approval refers to zero or one Date_time in the role of actual_date. Each Date_time acts as actual_date for zero, one, or more Approval objects.

4.3.217 Approval to Date_time

Each Approval refers to zero or one Date_time in the role of planned_date. Each Date_time acts as planned_date for zero, one, or more Approval objects.

4.3.218 Approval to Design_discipline_item_definition

Each Approval is_applied_to one or more Design_discipline_item_definition objects. Each Design_discipline_item_definition is related to zero, one, or more Approval objects.

4.3.219 Approval to Device

Each Approval is_applied_to one or more Device objects. Each Device is related to zero, one, or more Approval objects.

4.3.220 Approval to Device_relationship

Each Approval is_applied_to one or more Device_relationship objects. Each Device_relationship is related to zero, one, or more Approval objects.

4.3.221 Approval to Document

Each Approval is_applied_to one or more Document objects. Each Document is related to zero, one, or more Approval objects.

4.3.222 Approval to Document_file

Each Approval is_applied_to one or more Document_file objects. Each Document_file is related to zero, one, or more Approval objects.

4.3.223 Approval to Document_file_relationship

Each Approval is_applied_to one or more Document_file_relationship objects. Each Document_file_relationship is related to zero, one, or more Approval objects.

4.3.224 Approval to Document_representation

Each Approval is_applied_to one or more Document_representation objects. Each Document_representation is related to zero, one, or more Approval objects.

4.3.225 Approval to Document_version

Each Approval is_applied_to one or more Document_version objects. Each Document_version is related to zero, one, or more Approval objects.

4.3.226 Approval to Document_version_relationship

Each Approval is_applied_to one or more Document_version_relationship objects. Each Document_version_relationship is related to zero, one, or more Approval objects.

4.3.227 Approval to Drawing

Each Approval is_applied_to one or more Drawing objects. Each Drawing is related to zero, one, or more Approval objects.

4.3.228 Approval to Drawing_sequence

Each Approval is_applied_to one or more Drawing_sequence objects. Each Drawing_sequence is related to zero, one, or more Approval objects.

4.3.229 Approval to Drawing_sheet

Each Approval is_applied_to one or more Drawing_sheet objects. Each Drawing_sheet is related to zero, one, or more Approval objects.

4.3.230 Approval to Drawing_sheet_relationship

Each Approval is_applied_to one or more Drawing_sheet_relationship objects. Each Drawing_sheet_relationship is related to zero, one, or more Approval objects.

4.3.231 Approval to Function_definition

Each Approval is_applied_to one or more Function_definition objects. Each Function_definition is related to zero, one, or more Approval objects.

4.3.232 Approval to Function_definition_relationship

Each Approval is_applied_to one or more Function_definition_relationship objects. Each Function_definition_relationship is related to zero, one, or more Approval objects.

4.3.233 Approval to Function_interface

Each Approval is_applied_to one or more Function_interface objects. Each Function_interface is related to zero, one, or more Approval objects.

4.3.234 Approval to Function_unit

Each Approval is_applied_to one or more Function_unit objects. Each Function_unit is related to zero, one, or more Approval objects.

4.3.235 Approval to Function_unit_relationship

Each Approval is_applied_to one or more Function_unit_relationship objects. Each Function_unit_relationship is related to zero, one, or more Approval objects.

4.3.236 Approval to Function_version

Each Approval is_applied_to one or more Function_version objects. Each Function_version is related to zero, one, or more Approval objects.

4.3.237 Approval to Function_version_relationship

Each Approval is_applied_to one or more Function_version_relationship objects. Each Function_version_relationship is related to zero, one, or more Approval objects.

4.3.238 Approval to Functional_connectivity_definition

Each Approval is_applied_to one or more Functional_connectivity_definition objects. Each Functional_connectivity_definition is related to zero, one, or more Approval objects.

4.3.239 Approval to Functional_connectivity_definition_relationship

Each Approval is_applied_to one or more Functional_connectivity_definition_relationship objects. Each Functional_connectivity_definition_relationship is related to zero, one, or more Approval objects.

4.3.240 Approval to Functional_unit_allocation

Each Approval is_applied_to one or more Functional_unit_allocation objects. Each Functional_unit_allocation is related to zero, one, or more Approval objects.

4.3.241 Approval to General_classification

Each Approval is_applied_to one or more General_classification objects. Each General_classification is related to zero, one, or more Approval objects.

4.3.242 Approval to Generic_note

Each Approval is_applied_to one or more Generic_note objects. Each Generic_note is related to zero, one, or more Approval objects.

4.3.243 Approval to Interface

Each Approval is_applied_to one or more Interface objects. Each Interface is related to zero, one, or more Approval objects.

4.3.244 Approval to Interface_port

Each Approval is_applied_to one or more Interface_port objects. Each Interface_port is related to zero, one, or more Approval objects.

4.3.245 Approval to Interface_terminal

Each Approval is_applied_to one or more Interface_terminal objects. Each Interface_terminal is related to zero, one, or more Approval objects.

4.3.246 Approval to Item_definition_relationship

Each Approval is_applied_to one or more Item_definition_relationship objects. Each Item_definition_relationship is related to zero, one, or more Approval objects.

4.3.247 Approval to Item_version

Each Approval is_applied_to one or more Item_version objects. Each Item_version is related to zero, one, or more Approval objects.

4.3.248 Approval to Item_version_relationship

Each Approval is_applied_to one or more Item_version_relationship objects. Each Item_version_relationship is related to zero, one, or more Approval objects.

4.3.249 Approval to Location

Each Approval is_applied_to one or more Location objects. Each Location is related to zero, one, or more Approval objects.

4.3.250 Approval to Location_relationship

Each Approval is_applied_to one or more Location_relationship objects. Each Location_relationship is related to zero, one, or more Approval objects.

4.3.251 Approval to Manufacturing_configuration

Each Approval is_applied_to one or more Manufacturing_configuration objects. Each Manufacturing_configuration is related to zero, one, or more Approval objects.

4.3.252 Approval to Marking

Each Approval is_applied_to one or more Marking objects. Each Marking is related to zero, one, or more Approval objects.

4.3.253 Approval to Material

Each Approval is_applied_to one or more Material objects. Each Material is related to zero, one, or more Approval objects.

4.3.254 Approval to Node

Each Approval is_applied_to one or more Node objects. Each Node is related to zero, one, or more Approval objects.

4.3.255 Approval to Node_relationship

Each Approval is_applied_to one or more Node_relationship objects. Each Node_relationship is related to zero, one, or more Approval objects.

4.3.256 Approval to Notification

Each Approval is_applied_to one or more Notification objects. Each Notification is related to zero, one, or more Approval objects.

4.3.257 Approval to Notification_relationship

Each Approval is_applied_to one or more Notification_relationship objects. Each Notification_relationship is related to zero, one, or more Approval objects.

4.3.258 Approval to Offered_function_allocation

Each Approval is_applied_to one or more Offered_function_allocation objects. Each Offered_function_allocation is related to zero, one, or more Approval objects.

4.3.259 Approval to Organization

Each Approval refers to zero, one, or more Organization objects in the role of scope. Each Organization acts as scope for zero, one, or more Approval objects.

4.3.260 Approval to Path

Each Approval is_applied_to one or more Path objects. Each Path is related to zero, one, or more Approval objects.

4.3.261 Approval to Path_node

Each Approval is_applied_to one or more Path_node objects. Each Path_node is related to zero, one, or more Approval objects.

4.3.262 Approval to Path_node_relationship

Each Approval is_applied_to one or more Path_node_relationship objects. Each Path_node_relationship is related to zero, one, or more Approval objects.

4.3.263 Approval to Path_relationship

Each Approval is_applied_to one or more Path_relationship objects. Each Path_relationship is related to zero, one, or more Approval objects.

4.3.264 Approval to Physical_assembly_relationship

Each Approval is_applied_to one or more Physical_assembly_relationship objects. Each Physical_assembly_relationship is related to zero, one, or more Approval objects.

4.3.265 Approval to Physical_instance

Each Approval is_applied_to one or more Physical_instance objects. Each Physical_instance is related to zero, one, or more Approval objects.

4.3.266 Approval to Port

Each Approval is_applied_to one or more Port objects. Each Port is related to zero, one, or more Approval objects.

4.3.267 Approval to Port_allocation

Each Approval is_applied_to one or more Port_allocation objects. Each Port_allocation is related to zero, one, or more Approval objects.

4.3.268 Approval to Preferred_item_allocation

Each Approval is_applied_to one or more Preferred_item_allocation objects. Each Preferred_item_allocation is related to zero, one, or more Approval objects.

4.3.269 Approval to Preferred_item_terminal_allocation

Each Approval is_applied_to one or more Preferred_item_terminal_allocation objects. Each Preferred_item_terminal_allocation is related to zero, one, or more Approval objects.

4.3.270 Approval to Process_variable

Each Approval is_applied_to one or more Process_variable objects. Each Process_variable is related to zero, one, or more Approval objects.

4.3.271 Approval to Process_variable_relationship

Each Approval is_applied_to one or more Process_variable_relationship objects. Each Process_variable_relationship is related to zero, one, or more Approval objects.

4.3.272 Approval to Product_class

Each Approval is_applied_to one or more Product_class objects. Each Product_class is related to zero, one, or more Approval objects.

4.3.273 Approval to Product_identification

Each Approval is_applied_to one or more Product_identification objects. Each Product_identification is related to zero, one, or more Approval objects.

4.3.274 Approval to Product_structure_relationship

Each Approval is_applied_to one or more Product_structure_relationship objects. Each Product_structure_relationship is related to zero, one, or more Approval objects.

4.3.275 Approval to Project

Each Approval is_applied_to one or more Project objects. Each Project is related to zero, one, or more Approval objects.

4.3.276 Approval to Requirement

Each Approval is_applied_to one or more Requirement objects. Each Requirement is related to zero, one, or more Approval objects.

4.3.277 Approval to Route

Each Approval is_applied_to one or more Route objects. Each Route is related to zero, one, or more Approval objects.

4.3.278 Approval to Route_relationship

Each Approval is_applied_to one or more Route_relationship objects. Each Route_relationship is related to zero, one, or more Approval objects.

4.3.279 Approval to Section

Each Approval is_applied_to one or more Section objects. Each Section is related to zero, one, or more Approval objects.

4.3.280 Approval to Section_end

Each Approval is_applied_to one or more Section_end objects. Each Section_end is related to zero, one, or more Approval objects.

4.3.281 Approval to Section_interface

Each Approval is_applied_to one or more Section_interface objects. Each Section_interface is related to zero, one, or more Approval objects.

4.3.282 Approval to Section_interface_relationship

Each Approval is_applied_to one or more Section_interface_relationship objects. Each Section_interface_relationship is related to zero, one, or more Approval objects.

4.3.283 Approval to Section_relationship

Each Approval is_applied_to one or more Section_relationship objects. Each Section_relationship is related to zero, one, or more Approval objects.

4.3.284 Approval to Security_classification

Each Approval is_applied_to one or more Security_classification objects. Each Security_classification is related to zero, one, or more Approval objects.

4.3.285 Approval to Signal

Each Approval is_applied_to one or more Signal objects. Each Signal is related to zero, one, or more Approval objects.

4.3.286 Approval to Signal_relationship

Each Approval is_applied_to one or more Signal_relationship objects. Each Signal_relationship is related to zero, one, or more Approval objects.

4.3.287 Approval to Signal_value

Each Approval is_applied_to one or more Signal_value objects. Each Signal_value is related to zero, one, or more Approval objects.

4.3.288 Approval to Specification

Each Approval is_applied_to one or more Specification objects. Each Specification is related to zero, one, or more Approval objects.

4.3.289 Approval to Specification_category

Each Approval is_applied_to one or more Specification_category objects. Each Specification_category is related to zero, one, or more Approval objects.

4.3.290 Approval to Specification_expression

Each Approval is_applied_to one or more Specification_expression objects. Each Specification_expression is related to zero, one, or more Approval objects.

4.3.291 Approval to Specification_inclusion

Each Approval is_applied_to one or more Specification_inclusion objects. Each Specification_inclusion is related to zero, one, or more Approval objects.

4.3.292 Approval to Technical_system

Each Approval is_applied_to one or more Technical_system objects. Each Technical_system is related to zero, one, or more Approval objects.

4.3.293 Approval to Technical_system_relationship

Each Approval is_applied_to one or more Technical_system_relationship objects. Each Technical_system_relationship is related to zero, one, or more Approval objects.

4.3.294 Approval to Terminal

Each Approval is_applied_to one or more Terminal objects. Each Terminal is related to zero, one, or more Approval objects.

4.3.295 Approval to Work_order

Each Approval is_applied_to one or more Work_order objects. Each Work_order is related to zero, one, or more Approval objects.

4.3.296 Approval to Work_request

Each Approval is_applied_to one or more Work_request objects. Each Work_request is related to zero, one, or more Approval objects.

4.3.297 Approval_relationship to Approval

Each Approval_relationship refers to exactly one Approval in the role of related. Each Approval acts as related for zero, one, or more Approval_relationship objects.

4.3.298 Approval_relationship to Approval

Each Approval_relationship refers to exactly one Approval in the role of relating. Each Approval acts as relating for zero, one, or more Approval_relationship objects.

4.3.299 Approval_status to Classification_system

Each Approval_status refers to zero or one Classification_system in the role of used_classification_system. Each Classification_system acts as used_classification_system for zero, one, or more Approval_status objects.

4.3.300 Assembly_component_relationship to Assembly_definition

Each Assembly_component_relationship refers to exactly one Assembly_definition in the role of relating. Each Assembly_definition acts as relating for zero, one, or more Assembly_component_relationship objects.

4.3.301 Assembly_component_relationship to Device

Each Assembly_component_relationship refers to exactly one Device in the role of related. Each Device acts as related for zero, one, or more Assembly_component_relationship objects.

4.3.302 Assembly_substitute_relationship to Assembly_component_relationship

Each Assembly_substitute_relationship refers to exactly one Assembly_component_relationship in the role of base. Each Assembly_component_relationship acts as base for zero, one, or more Assembly_substitute_relationship objects.

4.3.303 Assembly_substitute_relationship to Assembly_component_-relationship

Each Assembly_substitute_relationship refers to exactly one Assembly_component_relationship in the role of substitute. Each Assembly_component_relationship acts as substitute for zero, one, or more Assembly_substitute_relationship objects.

4.3.304 Body_breadth to Value_with_unit

Each Body_breadth refers to exactly one Value_with_unit in the role of value_of_body_breadth. Each Value_with_unit acts as value_of_body_breadth for zero, one, or more Body_breadth objects.

4.3.305 Body_height to Value_with_unit

Each Body_height refers to exactly one Value_with_unit in the role of value_of_body_height. Each Value_with_unit acts as value_of_body_height for zero, one, or more Body_height objects.

4.3.306 Body_length to Value_with_unit

Each Body_length refers to exactly one Value_with_unit in the role of value_of_body_length. Each Value_with_unit acts as value_of_body_length for zero, one, or more Body_length objects.

4.3.307 Cable_pull_information to Routed_object

Each Cable_pull_information refers to one or more Routed_object objects in the role of associated_object. Each Routed_object acts as associated_object for zero, one, or more Cable_pull_information objects.

4.3.308 Cartesian_coordinate_space_2d to Numerical_precision

Each Cartesian_coordinate_space_2d refers to exactly one Numerical_precision in the role of precision. Each Numerical_precision acts as precision for zero, one, or more Cartesian_coordinate_space_2d objects.

4.3.309 Cartesian_coordinate_space_3d to Numerical_precision

Each Cartesian_coordinate_space_3d refers to exactly one Numerical_precision in the role of precision. Each Numerical_precision acts as precision for zero, one, or more Cartesian_coordinate_space_3d objects.

4.3.310 Certification to Device

Each Certification is_applied_to one or more Device objects. Each Device is related to zero, one, or more Certification objects.

4.3.311 Certification to Item_version

Each Certification is_applied_to one or more Item_version objects. Each Item_version is related to zero, one, or more Certification objects.

4.3.312 Certification to Item_version_relationship

Each Certification is_applied_to one or more Item_version_relationship objects. Each Item_version_relationship is related to zero, one, or more Certification objects.

4.3.313 Certification to Supplier_solution

Each Certification is_applied_to one or more Supplier_solution objects. Each Supplier_solution is related to zero, one, or more Certification objects.

4.3.314 Class_category_association to Product_class

Each Class_category_association refers to exactly one Product_class in the role of associated_product_class. Each Product_class acts as associated_product_class for zero, one, or more Class_category_association objects.

4.3.315 Class_category_association to Specification_category

Each Class_category_association refers to exactly one Specification_category in the role of associated_category. Each Specification_category acts as associated_category for zero, one, or more Class_category_association objects.

4.3.316 Class_condition_association to Product_class

Each Class_condition_association refers to exactly one Product_class in the role of associated_product_class. Each Product_class acts as associated_product_class for zero, one, or more Class_condition_association objects.

4.3.317 Class_condition_association to Specification_expression

Each Class_condition_association refers to exactly one Specification_expression in the role of associated_condition. Each Specification_expression acts as associated_condition for zero, one, or more Class_condition_association objects.

4.3.318 Class_inclusion_association to Product_class

Each Class_inclusion_association refers to exactly one Product_class in the role of associated_product_class. Each Product_class acts as associated_product_class for zero, one, or more Class_inclusion_association objects.

4.3.319 Class_inclusion_association to Specification_inclusion

Each Class_inclusion_association refers to exactly one Specification_inclusion in the role of associated_inclusion. Each Specification_inclusion acts as associated_inclusion for zero, one, or more Class_inclusion_association objects.

4.3.320 Class_specification_association to Product_class

Each Class_specification_association refers to exactly one Product_class in the role of associated_product_class. Each Product_class acts as associated_product_class for zero, one, or more Class_specification_association objects.

4.3.321 Class_specification_association to Specification

Each Class_specification_association refers to exactly one Specification in the role of associated_specification. Each Specification acts as associated_specification for zero, one, or more Class_specification_association objects.

4.3.322 Class_structure_relationship to Function_definition

Each Class_structure_relationship refers to exactly one Function_definition in the role of related. Each Function_definition acts as related for zero, one, or more Class_structure_relationship objects.

4.3.323 Class_structure_relationship to Product_class

Each Class_structure_relationship refers to exactly one Product_class in the role of relating. Each Product_class acts as relating for zero, one, or more Class_structure_relationship objects.

4.3.324 Class_structure_relationship to Product_component

Each Class_structure_relationship refers to exactly one Product_component in the role of related. Each Product_component acts as related for zero, one, or more Class_structure_relationship objects.

4.3.325 Classification_association to Activity

Each Classification_association refers to exactly one Activity in the role of classified_element. Each Activity acts as classified_element for zero, one, or more Classification_association objects.

4.3.326 Classification_association to Activity_method

Each Classification_association refers to exactly one Activity_method in the role of classified_element. Each Activity_method acts as classified_element for zero, one, or more Classification_association objects.

4.3.327 Classification_association to Annotation_subfigure_definition

Each Classification_association refers to exactly one Annotation_subfigure_definition in the role of classified_element. Each Annotation_subfigure_definition acts as classified_element for zero, one, or more Classification_association objects.

4.3.328 Classification_association to Approval

Each Classification_association refers to exactly one Approval in the role of classified_element. Each Approval acts as classified_element for zero, one, or more Classification_association objects.

4.3.329 Classification_association to Approval_status

ISO 10303-212:2001(E)

Each Classification_association refers to exactly one Approval_status in the role of classified_element. Each Approval_status acts as classified_element for zero, one, or more Classification_association objects.

4.3.330 Classification_association to Complex_product

Each Classification_association refers to exactly one Complex_product in the role of classified_element. Each Complex_product acts as classified_element for zero, one, or more Classification_association objects.

4.3.331 Classification_association to Connectivity_definition

Each Classification_association refers to exactly one Connectivity_definition in the role of classified_element. Each Connectivity_definition acts as classified_element for zero, one, or more Classification_association objects.

4.3.332 Classification_association to Contract

Each Classification_association refers to exactly one Contract in the role of classified_element. Each Contract acts as classified_element for zero, one, or more Classification_association objects.

4.3.333 Classification_association to Data_element

Each Classification_association refers to exactly one Data_element in the role of classified_element. Each Data_element acts as classified_element for zero, one, or more Classification_association objects.

4.3.334 Classification_association to Data_element_association

Each Classification_association refers to exactly one Data_element_association in the role of classified_element. Each Data_element_association acts as classified_element for zero, one, or more Classification_association objects.

4.3.335 Classification_association to Data_element_definition

Each Classification_association refers to exactly one Data_element_definition in the role of classified_element. Each Data_element_definition acts as classified_element for zero, one, or more Classification_association objects.

4.3.336 Classification_association to Design_discipline_item_definition

Each Classification_association refers to exactly one Design_discipline_item_definition in the role of classified_element. Each Design_discipline_item_definition acts as classified_element for zero, one, or more Classification_association objects.

4.3.337 Classification_association to Device

Each Classification_association refers to exactly one Device in the role of classified_element. Each Device acts as classified_element for zero, one, or more Classification_association objects.

4.3.338 Classification_association to Document

Each Classification_association refers to exactly one Document in the role of classified_element. Each Document acts as classified_element for zero, one, or more Classification_association objects.

4.3.339 Classification_association to Document_file

Each Classification_association refers to exactly one Document_file in the role of classified_element. Each Document_file acts as classified_element for zero, one, or more Classification_association objects.

4.3.340 Classification_association to Document_version

Each Classification_association refers to exactly one Document_version in the role of classified_element. Each Document_version acts as classified_element for zero, one, or more Classification_association objects.

4.3.341 Classification_association to Drawing

Each Classification_association refers to exactly one Drawing in the role of classified_element. Each Drawing acts as classified_element for zero, one, or more Classification_association objects.

4.3.342 Classification_association to Drawing_sheet

Each Classification_association refers to exactly one Drawing_sheet in the role of classified_element. Each Drawing_sheet acts as classified_element for zero, one, or more Classification_association objects.

4.3.343 Classification_association to Function_definition

Each Classification_association refers to exactly one Function_definition in the role of classified_element. Each Function_definition acts as classified_element for zero, one, or more Classification_association objects.

4.3.344 Classification_association to Function_unit

Each Classification_association refers to exactly one Function_unit in the role of classified_element. Each Function_unit acts as classified_element for zero, one, or more Classification_association objects.

4.3.345 Classification_association to Function_version

Each Classification_association refers to exactly one Function_version in the role of classified_element. Each Function_version acts as classified_element for zero, one, or more Classification_association objects.

4.3.346 Classification_association to Functional_connectivity_definition

Each Classification_association refers to exactly one Functional_connectivity_definition in the role of classified_element. Each Functional_connectivity_definition acts as classified_element for zero, one, or more Classification_association objects.

4.3.347 Classification_association to Functionality

Each Classification_association refers to exactly one Functionality in the role of classified_element. Each Functionality acts as classified_element for zero, one, or more Classification_association objects.

4.3.348 Classification_association to General_classification

Each Classification_association refers to exactly one General_classification in the role of classification. Each General_classification acts as classification for zero, one, or more Classification_association objects.

4.3.349 Classification_association to Interface_port

Each Classification_association refers to exactly one Interface_port in the role of classified_element. Each Interface_port acts as classified_element for zero, one, or more Classification_association objects.

4.3.350 Classification_association to Interface_terminal

Each Classification_association refers to exactly one Interface_terminal in the role of classified_element. Each Interface_terminal acts as classified_element for zero, one, or more Classification_association objects.

4.3.351 Classification_association to Item

Each Classification_association refers to exactly one Item in the role of classified_element. Each Item acts as classified_element for zero, one, or more Classification_association objects.

4.3.352 Classification_association to Item_version

Each Classification_association refers to exactly one Item_version in the role of classified_element. Each Item_version acts as classified_element for zero, one, or more Classification_association objects.

4.3.353 Classification_association to Location

Each Classification_association refers to exactly one Location in the role of classified_element. Each Location acts as classified_element for zero, one, or more Classification_association objects.

4.3.354 Classification_association to Path

Each Classification_association refers to exactly one Path in the role of classified_element. Each Path acts as classified_element for zero, one, or more Classification_association objects.

4.3.355 Classification_association to Path_node

Each Classification_association refers to exactly one Path_node in the role of classified_element. Each Path_node acts as classified_element for zero, one, or more Classification_association objects.

4.3.356 Classification_association to Port

Each Classification_association refers to exactly one Port in the role of classified_element. Each Port acts as classified_element for zero, one, or more Classification_association objects.

4.3.357 Classification_association to Product_class

Each Classification_association refers to exactly one Product_class in the role of classified_element. Each Product_class acts as classified_element for zero, one, or more Classification_association objects.

4.3.358 Classification_association to Product_identification

Each Classification_association refers to exactly one Product_identification in the role of classified_element. Each Product_identification acts as classified_element for zero, one, or more Classification_association objects.

4.3.359 Classification_association to Project

Each Classification_association refers to exactly one Project in the role of classified_element. Each Project acts as classified_element for zero, one, or more Classification_association objects.

4.3.360 Classification_association to Requirement

Each Classification_association refers to exactly one Requirement in the role of classified_element. Each Requirement acts as classified_element for zero, one, or more Classification_association objects.

4.3.361 Classification_association to Route

Each Classification_association refers to exactly one Route in the role of classified_element. Each Route acts as classified_element for zero, one, or more Classification_association objects.

4.3.362 Classification_association to Section

Each Classification_association refers to exactly one Section in the role of classified_element. Each Section acts as classified_element for zero, one, or more Classification_association objects.

4.3.363 Classification_association to Section_interface

Each Classification_association refers to exactly one Section_interface in the role of classified_element. Each Section_interface acts as classified_element for zero, one, or more Classification_association objects.

4.3.364 Classification_association to Security_level

ISO 10303-212:2001(E)

Each Classification_association refers to exactly one Security_level in the role of classified_element. Each Security_level acts as classified_element for zero, one, or more Classification_association objects.

4.3.365 Classification_association to Signal

Each Classification_association refers to exactly one Signal in the role of classified_element. Each Signal acts as classified_element for zero, one, or more Classification_association objects.

4.3.366 Classification_association to Specification_category

Each Classification_association refers to exactly one Specification_category in the role of classified_element. Each Specification_category acts as classified_element for zero, one, or more Classification_association objects.

4.3.367 Classification_association to Terminal

Each Classification_association refers to exactly one Terminal in the role of classified_element. Each Terminal acts as classified_element for zero, one, or more Classification_association objects.

4.3.368 Classification_association to Typical_schematic_node

Each Classification_association refers to exactly one Typical_schematic_node in the role of classified_element. Each Typical_schematic_node acts as classified_element for zero, one, or more Classification_association objects.

4.3.369 Classification_association to User_defined_symbol_definition

Each Classification_association refers to exactly one User_defined_symbol_definition in the role of classified_element. Each User_defined_symbol_definition acts as classified_element for zero, one, or more Classification_association objects.

4.3.370 Classification_association to Work_order

Each Classification_association refers to exactly one Work_order in the role of classified_element. Each Work_order acts as classified_element for zero, one, or more Classification_association objects.

4.3.371 Classification_association to Work_request

Each Classification_association refers to exactly one Work_request in the role of classified_element. Each Work_request acts as classified_element for zero, one, or more Classification_association objects.

4.3.372 Classification_attribute to Data_element

Each Classification_attribute refers to zero, one, or more Data_element objects in the role of allowed_value. Each Data_element acts as allowed_value for zero, one, or more Classification_attribute objects.

4.3.373 Classification_attribute to Data_element_definition

Each Classification_attribute refers to exactly one Data_element_definition in the role of attribute_definition. Each Data_element_definition acts as attribute_definition for zero, one, or more Classification_attribute objects.

4.3.374 Classification_attribute to General_classification

Each Classification_attribute refers to exactly one General_classification in the role of associated_classification. Each General_classification acts as associated_classification for zero, one, or more Classification_attribute objects.

4.3.375 Coded_size to Classification_system

Each Coded_size refers to exactly one Classification_system in the role of referenced_standard. Each Classification_system acts as referenced_standard for zero, one, or more Coded_size objects.

4.3.376 Complex_product_relationship to Complex_product

Each Complex_product_relationship refers to exactly one Complex_product in the role of related. Each Complex_product acts as related for zero, one, or more Complex_product_relationship objects.

4.3.377 Complex_product_relationship to Complex_product

Each Complex_product_relationship refers to exactly one Complex_product in the role of relating. Each Complex_product acts as relating for zero, one, or more Complex_product_relationship objects.

4.3.378 Component_colour to Classification_system

Each Component_colour refers to zero or one Classification_system in the role of coding_system. Each Classification_system acts as coding_system for zero, one, or more Component_colour objects.

4.3.379 Component_placement to Product_component

Each Component_placement refers to exactly one Product_component in the role of placed_component. Each Product_component acts as placed_component for zero, one, or more Component_placement objects.

4.3.380 Component_placement to Product_component

Each Component_placement refers to exactly one Product_component in the role of reference_product_component. Each Product_component acts as reference_product_component for zero, one, or more Component_placement objects.

4.3.381 Composition_relationship to Function_definition

Each Composition_relationship refers to exactly one Function_definition in the role of composed_function. Each Function_definition acts as composed_function for zero, one, or more Composition_relationship objects.

4.3.382 Composition_relationship to Function_unit

Each Composition_relationship refers to exactly one Function_unit in the role of functional_component. Each Function_unit acts as functional_component for zero, one, or more Composition_relationship objects.

4.3.383 Configuration to Class_condition_association

Each Configuration is_solution_for exactly one Class_condition_association. Each Class_condition_association is related to zero, one, or more Configuration objects.

4.3.384 Configuration to Class_specification_association

Each Configuration is_solution_for exactly one Class_specification_association. Each Class_specification_association is related to zero, one, or more Configuration objects.

4.3.385 Configuration to Complex_product

Each Configuration refers to exactly one Complex_product in the role of configured_element. Each Complex_product acts as configured_element for zero, one, or more Configuration objects.

4.3.386 Configuration to Connectivity_definition

Each Configuration refers to exactly one Connectivity_definition in the role of configured_element. Each Connectivity_definition acts as configured_element for zero, one, or more Configuration objects.

4.3.387 Configuration to Device

Each Configuration refers to exactly one Device in the role of configured_element. Each Device acts as configured_element for zero, one, or more Configuration objects.

4.3.388 Configuration to Function_unit

Each Configuration refers to exactly one Function_unit in the role of configured_element. Each Function_unit acts as configured_element for zero, one, or more Configuration objects.

4.3.389 Configuration to Functional_connectivity_definition

Each Configuration refers to exactly one Functional_connectivity_definition in the role of configured_element. Each Functional_connectivity_definition acts as configured_element for zero, one, or more Configuration objects.

4.3.390 Configuration to Location

Each Configuration refers to exactly one Location in the role of configured_element. Each Location acts as configured_element for zero, one, or more Configuration objects.

4.3.391 Configuration to Signal

Each Configuration refers to exactly one Signal in the role of configured_element. Each Signal acts as configured_element for zero, one, or more Configuration objects.

4.3.392 Connect_area to Curve_2d

Each Connect_area refers to one or more Curve_2d objects in the role of defined_by. Each Curve_2d acts as defined_by for zero, one, or more Connect_area objects.

4.3.393 Connect_area to Point_2d

Each Connect_area refers to one or more Point_2d objects in the role of defined_by. Each Point_2d acts as defined_by for zero, one, or more Connect_area objects.

4.3.394 Connecting_line to Connectivity_definition

Each Connecting_line refers to exactly one Connectivity_definition in the role of presents. Each Connectivity_definition acts as presents for zero, one, or more Connecting_line objects.

4.3.395 Connecting_line to Functional_connectivity_definition

Each Connecting_line refers to exactly one Functional_connectivity_definition in the role of presents. Each Functional_connectivity_definition acts as presents for zero, one, or more Connecting_line objects.

4.3.396 Connection to Terminal

Each Connection refers to zero, one, or more Terminal objects in the role of connected_terminal. Each Terminal acts as connected_terminal for zero, one, or more Connection objects.

4.3.397 Connectivity_allocation to Connectivity_definition

Each Connectivity_allocation refers to exactly one Connectivity_definition in the role of connectivity_implementation. Each Connectivity_definition acts as connectivity_implementation for zero, one, or more Connectivity_allocation objects.

4.3.398 Connectivity_allocation to Device

Each Connectivity_allocation refers to exactly one Device in the role of connectivity_implementation. Each Device acts as connectivity_implementation for zero, one, or more Connectivity_allocation objects.

4.3.399 Connectivity_allocation to Function_unit

Each Connectivity_allocation refers to exactly one Function_unit in the role of connectivity_implementation. Each Function_unit acts as connectivity_implementation for zero, one, or more Connectivity_allocation objects.

4.3.400 Connectivity_allocation to Functional_connectivity_definition

ISO 10303-212:2001(E)

Each Connectivity_allocation refers to exactly one Functional_connectivity_definition in the role of allocated_connectivity_definition. Each Functional_connectivity_definition acts as allocated_connectivity_definition for zero, one, or more Connectivity_allocation objects.

4.3.401 Connectivity_allocation to Physical_instance

Each Connectivity_allocation refers to exactly one Physical_instance in the role of connectivity_implementation. Each Physical_instance acts as connectivity_implementation for zero, one, or more Connectivity_allocation objects.

4.3.402 Connectivity_definition to Assembly_definition

Each Connectivity_definition refers to exactly one Assembly_definition in the role of connectivity_of. Each Assembly_definition acts as connectivity_of for zero, one, or more Connectivity_definition objects.

4.3.403 Connectivity_definition to Device

Each Connectivity_definition refers to zero, one, or more Device objects in the role of implemented_by. Each Device acts as implemented_by for zero, one, or more Connectivity_definition objects.

4.3.404 Connectivity_definition to Physical_instance

Each Connectivity_definition refers to zero, one, or more Physical_instance objects in the role of implemented_by. Each Physical_instance acts as implemented_by for zero, one, or more Connectivity_definition objects.

4.3.405 Connectivity_definition_relationship to Connectivity_definition

Each Connectivity_definition_relationship refers to exactly one Connectivity_definition in the role of related. Each Connectivity_definition acts as related for zero, one, or more Connectivity_definition_relationship objects.

4.3.406 Connectivity_definition_relationship to Connectivity_definition

Each Connectivity_definition_relationship refers to exactly one Connectivity_definition in the role of relating. Each Connectivity_definition acts as relating for zero, one, or more Connectivity_definition_relationship objects.

4.3.407 Contract to Activity

Each Contract refers to zero, one, or more Activity objects in the role of contracted_element. Each Activity acts as contracted_element for zero, one, or more Contract objects.

4.3.408 Contract to Data_element

Each Contract refers to zero, one, or more Data_element objects in the role of contracted_element. Each Data_element acts as contracted_element for zero, one, or more Contract objects.

4.3.409 Contract to Design_discipline_item_definition

Each Contract refers to zero, one, or more Design_discipline_item_definition objects in the role of contracted_element. Each Design_discipline_item_definition acts as contracted_element for zero, one, or more Contract objects.

4.3.410 Contract to Device

Each Contract refers to zero, one, or more Device objects in the role of contracted_element. Each Device acts as contracted_element for zero, one, or more Contract objects.

4.3.411 Contract to Function_definition

Each Contract refers to zero, one, or more Function_definition objects in the role of contracted_element. Each Function_definition acts as contracted_element for zero, one, or more Contract objects.

4.3.412 Contract to Function_unit

Each Contract refers to zero, one, or more Function_unit objects in the role of contracted_element. Each Function_unit acts as contracted_element for zero, one, or more Contract objects.

4.3.413 Contract to Function_version

Each Contract refers to zero, one, or more Function_version objects in the role of contracted_element. Each Function_version acts as contracted_element for zero, one, or more Contract objects.

4.3.414 Contract to Item_version

Each Contract refers to zero, one, or more Item_version objects in the role of contracted_element. Each Item_version acts as contracted_element for zero, one, or more Contract objects.

4.3.415 Contract to Location

Each Contract refers to zero, one, or more Location objects in the role of contracted_element. Each Location acts as contracted_element for zero, one, or more Contract objects.

4.3.416 Contract to Node

Each Contract refers to zero, one, or more Node objects in the role of contracted_element. Each Node acts as contracted_element for zero, one, or more Contract objects.

4.3.417 Contract to Notification

Each Contract refers to zero, one, or more Notification objects in the role of contracted_element. Each Notification acts as contracted_element for zero, one, or more Contract objects.

4.3.418 Contract to Path

Each Contract refers to zero, one, or more Path objects in the role of contracted_element. Each Path acts as contracted_element for zero, one, or more Contract objects.

4.3.419 Contract to Path_node

Each Contract refers to zero, one, or more Path_node objects in the role of contracted_element. Each Path_node acts as contracted_element for zero, one, or more Contract objects.

4.3.420 Contract to Physical_instance

Each Contract refers to zero, one, or more Physical_instance objects in the role of contracted_element. Each Physical_instance acts as contracted_element for zero, one, or more Contract objects.

4.3.421 Contract to Process_variable

Each Contract refers to zero, one, or more Process_variable objects in the role of contracted_element. Each Process_variable acts as contracted_element for zero, one, or more Contract objects.

4.3.422 Contract to Project

Each Contract refers to zero, one, or more Project objects in the role of contracted_element. Each Project acts as contracted_element for zero, one, or more Contract objects.

4.3.423 Contract to Route

Each Contract refers to zero, one, or more Route objects in the role of contracted_element. Each Route acts as contracted_element for zero, one, or more Contract objects.

4.3.424 Contract to Section

Each Contract refers to zero, one, or more Section objects in the role of contracted_element. Each Section acts as contracted_element for zero, one, or more Contract objects.

4.3.425 Contract to Section_end

Each Contract refers to zero, one, or more Section_end objects in the role of contracted_element. Each Section_end acts as contracted_element for zero, one, or more Contract objects.

4.3.426 Contract to Section_interface

Each Contract refers to zero, one, or more Section_interface objects in the role of contracted_element. Each Section_interface acts as contracted_element for zero, one, or more Contract objects.

4.3.427 Contract to Signal

Each Contract refers to zero, one, or more Signal objects in the role of contracted_element. Each Signal acts as contracted_element for zero, one, or more Contract objects.

4.3.428 Contract to Signal_value

Each Contract refers to zero, one, or more Signal_value objects in the role of contracted_element. Each Signal_value acts as contracted_element for zero, one, or more Contract objects.

4.3.429 Contract to Technical_system

Each Contract refers to zero, one, or more Technical_system objects in the role of contracted_element. Each Technical_system acts as contracted_element for zero, one, or more Contract objects.

4.3.430 Contract to Work_order

Each Contract refers to zero, one, or more Work_order objects in the role of contracted_element. Each Work_order acts as contracted_element for zero, one, or more Contract objects.

4.3.431 Contract to Work_request

Each Contract refers to zero, one, or more Work_request objects in the role of contracted_element. Each Work_request acts as contracted_element for zero, one, or more Contract objects.

4.3.432 Cross_section to Value_with_unit

Each Cross_section refers to exactly one Value_with_unit in the role of value_of_cross_section. Each Value_with_unit acts as value_of_cross_section for zero, one, or more Cross_section objects.

4.3.433 Curve_appearance to Colour

Each Curve_appearance refers to exactly one Colour in the role of curve_colour. Each Colour acts as curve_colour for zero, one, or more Curve_appearance objects.

4.3.434 Curve_appearance to Line_font

Each Curve_appearance refers to exactly one Line_font in the role of font. Each Line_font acts as font for zero, one, or more Curve_appearance objects.

4.3.435 Curve_dimension to Dimension_line

Each Curve_dimension refers to exactly one Dimension_line in the role of extent. Each Dimension_line acts as extent for zero, one, or more Curve_dimension objects.

4.3.436 Curve_dimension to Projection_line

Each Curve_dimension refers to zero, one, or two Projection_line objects in the role of component. Each Projection_line acts as component for zero, one, or more Curve_dimension objects.

4.3.437 Data_element_association to Activity

Each Data_element_association refers to exactly one Activity in the role of associated_item. Each Activity acts as associated_item for zero, one, or more Data_element_association objects.

4.3.438 Data_element_association to Assembly_component_relationship

Each Data_element_association refers to exactly one Assembly_component_relationship in the role of associated_item. Each Assembly_component_relationship acts as associated_item for zero, one, or more Data_element_association objects.

4.3.439 Data_element_association to Cable_pull_information

Each Data_element_association refers to exactly one Cable_pull_information in the role of associated_item. Each Cable_pull_information acts as associated_item for zero, one, or more Data_element_association objects.

4.3.440 Data_element_association to Complex_product

Each Data_element_association refers to exactly one Complex_product in the role of associated_item. Each Complex_product acts as associated_item for zero, one, or more Data_element_association objects.

4.3.441 Data_element_association to Complex_product_relationship

Each Data_element_association refers to exactly one Complex_product_relationship in the role of associated_item. Each Complex_product_relationship acts as associated_item for zero, one, or more Data_element_association objects.

4.3.442 Data_element_association to Composition_relationship

Each Data_element_association refers to exactly one Composition_relationship in the role of associated_item. Each Composition_relationship acts as associated_item for zero, one, or more Data_element_association objects.

4.3.443 Data_element_association to Connectivity_allocation

Each Data_element_association refers to exactly one Connectivity_allocation in the role of associated_item. Each Connectivity_allocation acts as associated_item for zero, one, or more Data_element_association objects.

4.3.444 Data_element_association to Connectivity_definition

Each Data_element_association refers to exactly one Connectivity_definition in the role of associated_item. Each Connectivity_definition acts as associated_item for zero, one, or more Data_element_association objects.

4.3.445 Data_element_association to Connectivity_definition_relationship

Each Data_element_association refers to exactly one Connectivity_definition_relationship in the role of associated_item. Each Connectivity_definition_relationship acts as associated_item for zero, one, or more Data_element_association objects.

4.3.446 Data_element_association to Data_element

Each Data_element_association refers to exactly one Data_element in the role of associated_data_element. Each Data_element acts as associated_data_element for zero, one, or more Data_element_association objects.

4.3.447 Data_element_association to Design_discipline_item_definition

Each Data_element_association refers to exactly one Design_discipline_item_definition in the role of associated_item. Each Design_discipline_item_definition acts as associated_item for zero, one, or more Data_element_association objects.

4.3.448 Data_element_association to Device

Each Data_element_association refers to exactly one Device in the role of associated_item. Each Device acts as associated_item for zero, one, or more Data_element_association objects.

4.3.449 Data_element_association to Device_relationship

Each Data_element_association refers to exactly one Device_relationship in the role of associated_item. Each Device_relationship acts as associated_item for zero, one, or more Data_element_association objects.

4.3.450 Data_element_association to Document

Each Data_element_association refers to exactly one Document in the role of associated_item. Each Document acts as associated_item for zero, one, or more Data_element_association objects.

4.3.451 Data_element_association to Document_file

Each Data_element_association refers to exactly one Document_file in the role of associated_item. Each Document_file acts as associated_item for zero, one, or more Data_element_association objects.

4.3.452 Data_element_association to Document_representation

Each Data_element_association refers to exactly one Document_representation in the role of associated_item. Each Document_representation acts as associated_item for zero, one, or more Data_element_association objects.

4.3.453 Data_element_association to Document_version

Each Data_element_association refers to exactly one Document_version in the role of associated_item. Each Document_version acts as associated_item for zero, one, or more Data_element_association objects.

4.3.454 Data_element_association to Drawing_sheet

Each Data_element_association refers to exactly one Drawing_sheet in the role of associated_item. Each Drawing_sheet acts as associated_item for zero, one, or more Data_element_association objects.

4.3.455 Data_element_association to Free_segment

Each Data_element_association refers to exactly one Free_segment in the role of associated_item. Each Free_segment acts as associated_item for zero, one, or more Data_element_association objects.

4.3.456 Data_element_association to Function_definition

Each Data_element_association refers to exactly one Function_definition in the role of associated_item. Each Function_definition acts as associated_item for zero, one, or more Data_element_association objects.

4.3.457 Data_element_association to Function_definition_relationship

Each Data_element_association refers to exactly one Function_definition_relationship in the role of associated_item. Each Function_definition_relationship acts as associated_item for zero, one, or more Data_element_association objects.

4.3.458 Data_element_association to Function_interface

Each Data_element_association refers to exactly one Function_interface in the role of associated_item. Each Function_interface acts as associated_item for zero, one, or more Data_element_association objects.

4.3.459 Data_element_association to Function_unit

Each Data_element_association refers to exactly one Function_unit in the role of associated_item. Each Function_unit acts as associated_item for zero, one, or more Data_element_association objects.

4.3.460 Data_element_association to Function_unit_relationship

Each Data_element_association refers to exactly one Function_unit_relationship in the role of associated_item. Each Function_unit_relationship acts as associated_item for zero, one, or more Data_element_association objects.

4.3.461 Data_element_association to Function_version

Each Data_element_association refers to exactly one Function_version in the role of associated_item. Each Function_version acts as associated_item for zero, one, or more Data_element_association objects.

4.3.462 Data_element_association to Functional_connectivity_definition

Each Data_element_association refers to exactly one Functional_connectivity_definition in the role of associated_item. Each Functional_connectivity_definition acts as associated_item for zero, one, or more Data_element_association objects.

4.3.463 Data_element_association to Functional_connectivity_definition_relationship

Each Data_element_association refers to exactly one Functional_connectivity_definition_relationship in the role of associated_item. Each Functional_connectivity_definition_relationship acts as associated_item for zero, one, or more Data_element_association objects.

4.3.464 Data_element_association to Functional_unit_allocation

Each Data_element_association refers to exactly one Functional_unit_allocation in the role of associated_item. Each Functional_unit_allocation acts as associated_item for zero, one, or more Data_element_association objects.

4.3.465 Data_element_association to Functionality

Each Data_element_association refers to exactly one Functionality in the role of associated_item. Each Functionality acts as associated_item for zero, one, or more Data_element_association objects.

4.3.466 Data_element_association to Generic_note

Each Data_element_association refers to exactly one Generic_note in the role of associated_item. Each Generic_note acts as associated_item for zero, one, or more Data_element_association objects.

4.3.467 Data_element_association to Interface

Each Data_element_association refers to exactly one Interface in the role of associated_item. Each Interface acts as associated_item for zero, one, or more Data_element_association objects.

4.3.468 Data_element_association to Interface_port

Each Data_element_association refers to exactly one Interface_port in the role of associated_item. Each Interface_port acts as associated_item for zero, one, or more Data_element_association objects.

4.3.469 Data_element_association to Interface_terminal

Each Data_element_association refers to exactly one Interface_terminal in the role of associated_item. Each Interface_terminal acts as associated_item for zero, one, or more Data_element_association objects.

4.3.470 Data_element_association to Item

Each Data_element_association refers to exactly one Item in the role of associated_item. Each Item acts as associated_item for zero, one, or more Data_element_association objects.

4.3.471 Data_element_association to Item_definition_relationship

Each Data_element_association refers to exactly one Item_definition_relationship in the role of associated_item. Each Item_definition_relationship acts as associated_item for zero, one, or more Data_element_association objects.

4.3.472 Data_element_association to Item_version

Each Data_element_association refers to exactly one Item_version in the role of associated_item. Each Item_version acts as associated_item for zero, one, or more Data_element_association objects.

4.3.473 Data_element_association to Location

Each Data_element_association refers to exactly one Location in the role of associated_item. Each Location acts as associated_item for zero, one, or more Data_element_association objects.

4.3.474 Data_element_association to Location_relationship

Each Data_element_association refers to exactly one Location_relationship in the role of associated_item. Each Location_relationship acts as associated_item for zero, one, or more Data_element_association objects.

4.3.475 Data_element_association to Marking

Each Data_element_association refers to exactly one Marking in the role of associated_item. Each Marking acts as associated_item for zero, one, or more Data_element_association objects.

4.3.476 Data_element_association to Node

Each Data_element_association refers to exactly one Node in the role of associated_item. Each Node acts as associated_item for zero, one, or more Data_element_association objects.

4.3.477 Data_element_association to Node_relationship

Each Data_element_association refers to exactly one Node_relationship in the role of associated_item. Each Node_relationship acts as associated_item for zero, one, or more Data_element_association objects.

4.3.478 Data_element_association to Notification

Each Data_element_association refers to exactly one Notification in the role of associated_item. Each Notification acts as associated_item for zero, one, or more Data_element_association objects.

4.3.479 Data_element_association to Offered_function_allocation

Each Data_element_association refers to exactly one Offered_function_allocation in the role of associated_item. Each Offered_function_allocation acts as associated_item for zero, one, or more Data_element_association objects.

4.3.480 Data_element_association to Organization

Each Data_element_association refers to zero or one Organization in the role of data_element_context. Each Organization acts as data_element_context for zero, one, or more Data_element_association objects.

4.3.481 Data_element_association to Path

Each Data_element_association refers to exactly one Path in the role of associated_item. Each Path acts as associated_item for zero, one, or more Data_element_association objects.

4.3.482 Data_element_association to Path_node

Each Data_element_association refers to exactly one Path_node in the role of associated_item. Each Path_node acts as associated_item for zero, one, or more Data_element_association objects.

4.3.483 Data_element_association to Physical_assembly_relationship

Each Data_element_association refers to exactly one Physical_assembly_relationship in the role of associated_item. Each Physical_assembly_relationship acts as associated_item for zero, one, or more Data_element_association objects.

4.3.484 Data_element_association to Physical_instance

Each Data_element_association refers to exactly one Physical_instance in the role of associated_item. Each Physical_instance acts as associated_item for zero, one, or more Data_element_association objects.

4.3.485 Data_element_association to Port

Each Data_element_association refers to exactly one Port in the role of associated_item. Each Port acts as associated_item for zero, one, or more Data_element_association objects.

4.3.486 Data_element_association to Port_allocation

Each Data_element_association refers to exactly one Port_allocation in the role of associated_item. Each Port_allocation acts as associated_item for zero, one, or more Data_element_association objects.

4.3.487 Data_element_association to Port_association

Each Data_element_association refers to exactly one Port_association in the role of associated_item. Each Port_association acts as associated_item for zero, one, or more Data_element_association objects.

4.3.488 Data_element_association to Preferred_item_allocation

Each Data_element_association refers to exactly one Preferred_item_allocation in the role of associated_item. Each Preferred_item_allocation acts as associated_item for zero, one, or more Data_element_association objects.

4.3.489 Data_element_association to Preferred_item_terminal_allocation

Each Data_element_association refers to exactly one Preferred_item_terminal_allocation in the role of associated_item. Each Preferred_item_terminal_allocation acts as associated_item for zero, one, or more Data_element_association objects.

4.3.490 Data_element_association to Process_variable

Each Data_element_association refers to exactly one Process_variable in the role of associated_item. Each Process_variable acts as associated_item for zero, one, or more Data_element_association objects.

4.3.491 Data_element_association to Product_class

Each Data_element_association refers to exactly one Product_class in the role of associated_item. Each Product_class acts as associated_item for zero, one, or more Data_element_association objects.

4.3.492 Data_element_association to Product_class

Each Data_element_association refers to zero or one Product_class in the role of data_element_context. Each Product_class acts as data_element_context for zero, one, or more Data_element_association objects.

4.3.493 Data_element_association to Product_identification

Each Data_element_association refers to exactly one Product_identification in the role of associated_item. Each Product_identification acts as associated_item for zero, one, or more Data_element_association objects.

4.3.494 Data_element_association to Product_structure_relationship

Each Data_element_association refers to exactly one Product_structure_relationship in the role of associated_item. Each Product_structure_relationship acts as associated_item for zero, one, or more Data_element_association objects.

4.3.495 Data_element_association to Requirement

Each Data_element_association refers to exactly one Requirement in the role of associated_item. Each Requirement acts as associated_item for zero, one, or more Data_element_association objects.

4.3.496 Data_element_association to Route

Each Data_element_association refers to exactly one Route in the role of associated_item. Each Route acts as associated_item for zero, one, or more Data_element_association objects.

4.3.497 Data_element_association to Route_relationship

Each Data_element_association refers to exactly one Route_relationship in the role of associated_item. Each Route_relationship acts as associated_item for zero, one, or more Data_element_association objects.

4.3.498 Data_element_association to Routed_segment

Each Data_element_association refers to exactly one Routed_segment in the role of associated_item. Each Routed_segment acts as associated_item for zero, one, or more Data_element_association objects.

4.3.499 Data_element_association to Section

Each Data_element_association refers to exactly one Section in the role of associated_item. Each Section acts as associated_item for zero, one, or more Data_element_association objects.

4.3.500 Data_element_association to Section_end

Each Data_element_association refers to exactly one Section_end in the role of associated_item. Each Section_end acts as associated_item for zero, one, or more Data_element_association objects.

4.3.501 Data_element_association to Section_interface

Each Data_element_association refers to exactly one Section_interface in the role of associated_item. Each Section_interface acts as associated_item for zero, one, or more Data_element_association objects.

4.3.502 Data_element_association to Section_interface_relationship

Each Data_element_association refers to exactly one Section_interface_relationship in the role of associated_item. Each Section_interface_relationship acts as associated_item for zero, one, or more Data_element_association objects.

4.3.503 Data_element_association to Section_relationship

Each Data_element_association refers to exactly one Section_relationship in the role of associated_item. Each Section_relationship acts as associated_item for zero, one, or more Data_element_association objects.

4.3.504 Data_element_association to Signal

Each Data_element_association refers to exactly one Signal in the role of associated_item. Each Signal acts as associated_item for zero, one, or more Data_element_association objects.

4.3.505 Data_element_association to Signal_value

Each Data_element_association refers to exactly one Signal_value in the role of associated_item. Each Signal_value acts as associated_item for zero, one, or more Data_element_association objects.

4.3.506 Data_element_association to Technical_system

Each Data_element_association refers to exactly one Technical_system in the role of associated_item. Each Technical_system acts as associated_item for zero, one, or more Data_element_association objects.

4.3.507 Data_element_association to Technical_system

Each Data_element_association refers to zero or one Technical_system in the role of data_element_context. Each Technical_system acts as data_element_context for zero, one, or more Data_element_association objects.

4.3.508 Data_element_association to Technical_system_relationship

Each Data_element_association refers to exactly one Technical_system_relationship in the role of associated_item. Each Technical_system_relationship acts as associated_item for zero, one, or more Data_element_association objects.

4.3.509 Data_element_association to Terminal

Each Data_element_association refers to exactly one Terminal in the role of associated_item. Each Terminal acts as associated_item for zero, one, or more Data_element_association objects.

4.3.510 Data_element_association to Work_order

Each Data_element_association refers to exactly one Work_order in the role of associated_item. Each Work_order acts as associated_item for zero, one, or more Data_element_association objects.

4.3.511 Data_element_definition to External_library_reference

Each Data_element_definition refers to zero or one External_library_reference in the role of source. Each External_library_reference acts as source for zero, one, or more Data_element_definition objects.

4.3.512 Data_element_definition to Property_reference

Each Data_element_definition refers to zero or one Property_reference in the role of source. Each Property_reference acts as source for zero, one, or more Data_element_definition objects.

4.3.513 Data_element_definition_relationship to Data_element_definition

Each Data_element_definition_relationship refers to exactly one Data_element_definition in the role of related. Each Data_element_definition acts as related for zero, one, or more Data_element_definition_relationship objects.

4.3.514 Data_element_definition_relationship to Data_element_definition

Each Data_element_definition_relationship refers to exactly one Data_element_definition in the role of relating. Each Data_element_definition acts as relating for zero, one, or more Data_element_definition_relationship objects.

4.3.515 Data_element_relationship to Data_element

Each Data_element_relationship refers to exactly one Data_element in the role of related. Each Data_element acts as related for zero, one, or more Data_element_relationship objects.

4.3.516 Data_element_relationship to Data_element

Each Data_element_relationship refers to exactly one Data_element in the role of relating. Each Data_element acts as relating for zero, one, or more Data_element_relationship objects.

4.3.517 Data_element_specification to Data_element_definition

Each Data_element_specification refers to exactly one Data_element_definition in the role of specification_of. Each Data_element_definition acts as specification_of for zero, one, or more Data_element_specification objects.

4.3.518 Data_element_specification to Language

Each Data_element_specification refers to zero or one Language in the role of language_specification. Each Language acts as language_specification for zero, one, or more Data_element_specification objects.

4.3.519 Date_and_person_assignment to Activity

Each Date_and_person_assignment is_applied_to one or more Activity objects. Each Activity is related to zero, one, or more Date_and_person_assignment objects.

4.3.520 Date_and_person_assignment to Activity_element

Each Date_and_person_assignment is_applied_to one or more Activity_element objects. Each Activity_element is related to zero, one, or more Date_and_person_assignment objects.

4.3.521 Date_and_person_assignment to Activity_method_assignment

Each Date_and_person_assignment is_applied_to one or more Activity_method_assignment objects. Each Activity_method_assignment is related to zero, one, or more Date_and_person_assignment objects.

4.3.522 Date_and_person_assignment to Activity_relationship

Each Date_and_person_assignment is_applied_to one or more Activity_relationship objects. Each Activity_relationship is related to zero, one, or more Date_and_person_assignment objects.

4.3.523 Date_and_person_assignment to Alternate_item_relationship

Each Date_and_person_assignment is_applied_to one or more Alternate_item_relationship objects. Each Alternate_item_relationship is related to zero, one, or more Date_and_person_assignment objects.

4.3.524 Date_and_person_assignment to Approval_status

Each Date_and_person_assignment is_applied_to one or more Approval_status objects. Each Approval_status is related to zero, one, or more Date_and_person_assignment objects.

4.3.525 Date_and_person_assignment to Assembly_component_- relationship

Each Date_and_person_assignment is_applied_to one or more Assembly_component_relationship objects. Each Assembly_component_relationship is related to zero, one, or more Date_and_person_assignment objects.

4.3.526 Date_and_person_assignment to Assembly_substitute_- relationship

Each Date_and_person_assignment is_applied_to one or more Assembly_substitute_relationship objects. Each Assembly_substitute_relationship is related to zero, one, or more Date_and_person_assignment objects.

4.3.527 Date_and_person_assignment to Cable_pull_information

Each Date_and_person_assignment is_applied_to one or more Cable_pull_information objects. Each Cable_pull_information is related to zero, one, or more Date_and_person_assignment objects.

4.3.528 Date_and_person_assignment to Certification

Each Date_and_person_assignment is_applied_to one or more Certification objects. Each Certification is related to zero, one, or more Date_and_person_assignment objects.

4.3.529 Date_and_person_assignment to Class_category_association

Each Date_and_person_assignment is_applied_to one or more Class_category_association objects. Each Class_category_association is related to zero, one, or more Date_and_person_assignment objects.

4.3.530 Date_and_person_assignment to Class_condition_association

Each Date_and_person_assignment is_applied_to one or more Class_condition_association objects. Each Class_condition_association is related to zero, one, or more Date_and_person_assignment objects.

4.3.531 Date_and_person_assignment to Class_inclusion_association

Each Date_and_person_assignment is_applied_to one or more Class_inclusion_association objects. Each Class_inclusion_association is related to zero, one, or more Date_and_person_assignment objects.

4.3.532 Date_and_person_assignment to Class_specification_association

Each Date_and_person_assignment is_applied_to one or more Class_specification_association objects. Each Class_specification_association is related to zero, one, or more Date_and_person_assignment objects.

4.3.533 Date_and_person_assignment to Class_structure_relationship

Each Date_and_person_assignment is_applied_to one or more Class_structure_relationship objects. Each Class_structure_relationship is related to zero, one, or more Date_and_person_assignment objects.

4.3.534 Date_and_person_assignment to Classification_association

Each Date_and_person_assignment is_applied_to one or more Classification_association objects. Each Classification_association is related to zero, one, or more Date_and_person_assignment objects.

4.3.535 Date_and_person_assignment to Classification_attribute

Each Date_and_person_assignment is_applied_to one or more Classification_attribute objects. Each Classification_attribute is related to zero, one, or more Date_and_person_assignment objects.

4.3.536 Date_and_person_assignment to Classification_system

Each Date_and_person_assignment is_applied_to one or more Classification_system objects. Each Classification_system is related to zero, one, or more Date_and_person_assignment objects.

4.3.537 Date_and_person_assignment to Complex_product

Each Date_and_person_assignment is_applied_to one or more Complex_product objects. Each Complex_product is related to zero, one, or more Date_and_person_assignment objects.

4.3.538 Date_and_person_assignment to Complex_product_relationship

Each Date_and_person_assignment is_applied_to one or more Complex_product_relationship objects. Each Complex_product_relationship is related to zero, one, or more Date_and_person_assignment objects.

4.3.539 Date_and_person_assignment to Composition_relationship

Each Date_and_person_assignment is_applied_to one or more Composition_relationship objects. Each Composition_relationship is related to zero, one, or more Date_and_person_assignment objects.

4.3.540 Date_and_person_assignment to Configuration

Each Date_and_person_assignment is_applied_to one or more Configuration objects. Each Configuration is related to zero, one, or more Date_and_person_assignment objects.

4.3.541 Date_and_person_assignment to Connectivity_allocation

Each Date_and_person_assignment is_applied_to one or more Connectivity_allocation objects. Each Connectivity_allocation is related to zero, one, or more Date_and_person_assignment objects.

4.3.542 Date_and_person_assignment to Connectivity_definition

Each Date_and_person_assignment is_applied_to one or more Connectivity_definition objects. Each Connectivity_definition is related to zero, one, or more Date_and_person_assignment objects.

4.3.543 Date_and_person_assignment to Connectivity_definition_relationship

Each Date_and_person_assignment is_applied_to one or more Connectivity_definition_relationship objects. Each Connectivity_definition_relationship is related to zero, one, or more Date_and_person_assignment objects.

4.3.544 Date_and_person_assignment to Contract

Each Date_and_person_assignment is_applied_to one or more Contract objects. Each Contract is related to zero, one, or more Date_and_person_assignment objects.

4.3.545 Date_and_person_assignment to Data_element

Each Date_and_person_assignment is_applied_to one or more Data_element objects. Each Data_element is related to zero, one, or more Date_and_person_assignment objects.

4.3.546 Date_and_person_assignment to Data_element_association

Each Date_and_person_assignment is_applied_to one or more Data_element_association objects. Each Data_element_association is related to zero, one, or more Date_and_person_assignment objects.

4.3.547 Date_and_person_assignment to Data_element_definition

Each Date_and_person_assignment is_applied_to one or more Data_element_definition objects. Each Data_element_definition is related to zero, one, or more Date_and_person_assignment objects.

4.3.548 Date_and_person_assignment to Data_element_relationship

Each Date_and_person_assignment is_applied_to one or more Data_element_relationship objects. Each Data_element_relationship is related to zero, one, or more Date_and_person_assignment objects.

4.3.549 Date_and_person_assignment to Data_element_specification

Each Date_and_person_assignment is_applied_to one or more Data_element_specification objects. Each Data_element_specification is related to zero, one, or more Date_and_person_assignment objects.

4.3.550 Date_and_person_assignment to Date_and_person_or_organization

Each Date_and_person_assignment refers to exactly one Date_and_person_or_organization in the role of assigned_date_and_person. Each Date_and_person_or_organization acts as assigned_date_and_person for zero, one, or more Date_and_person_assignment objects.

4.3.551 Date_and_person_assignment to Design_discipline_item_definition

Each Date_and_person_assignment is_applied_to one or more Design_discipline_item_definition objects. Each Design_discipline_item_definition is related to zero, one, or more Date_and_person_assignment objects.

4.3.552 Date_and_person_assignment to Device

Each Date_and_person_assignment is_applied_to one or more Device objects. Each Device is related to zero, one, or more Date_and_person_assignment objects.

4.3.553 Date_and_person_assignment to Device_relationship

Each Date_and_person_assignment is_applied_to one or more Device_relationship objects. Each Device_relationship is related to zero, one, or more Date_and_person_assignment objects.

4.3.554 Date_and_person_assignment to Document

Each Date_and_person_assignment is_applied_to one or more Document objects. Each Document is related to zero, one, or more Date_and_person_assignment objects.

4.3.555 Date_and_person_assignment to Document_file

Each Date_and_person_assignment is_applied_to one or more Document_file objects. Each Document_file is related to zero, one, or more Date_and_person_assignment objects.

4.3.556 Date_and_person_assignment to Document_file_relationship

Each Date_and_person_assignment is_applied_to one or more Document_file_relationship objects. Each Document_file_relationship is related to zero, one, or more Date_and_person_assignment objects.

4.3.557 Date_and_person_assignment to Document_representation

Each Date_and_person_assignment is_applied_to one or more Document_representation objects. Each Document_representation is related to zero, one, or more Date_and_person_assignment objects.

4.3.558 Date_and_person_assignment to Document_version

Each Date_and_person_assignment is_applied_to one or more Document_version objects. Each Document_version is related to zero, one, or more Date_and_person_assignment objects.

4.3.559 Date_and_person_assignment to Document_version_relationship

Each Date_and_person_assignment is_applied_to one or more Document_version_relationship objects. Each Document_version_relationship is related to zero, one, or more Date_and_person_assignment objects.

4.3.560 Date_and_person_assignment to Drawing

Each Date_and_person_assignment is_applied_to one or more Drawing objects. Each Drawing is related to zero, one, or more Date_and_person_assignment objects.

4.3.561 Date_and_person_assignment to Drawing_sequence

Each Date_and_person_assignment is_applied_to one or more Drawing_sequence objects. Each Drawing_sequence is related to zero, one, or more Date_and_person_assignment objects.

4.3.562 Date_and_person_assignment to Drawing_sheet

Each Date_and_person_assignment is_applied_to one or more Drawing_sheet objects. Each Drawing_sheet is related to zero, one, or more Date_and_person_assignment objects.

4.3.563 Date_and_person_assignment to Drawing_sheet_relationship

Each Date_and_person_assignment is_applied_to one or more Drawing_sheet_relationship objects. Each Drawing_sheet_relationship is related to zero, one, or more Date_and_person_assignment objects.

4.3.564 Date_and_person_assignment to Free_segment

Each Date_and_person_assignment is_applied_to one or more Free_segment objects. Each Free_segment is related to zero, one, or more Date_and_person_assignment objects.

4.3.565 Date_and_person_assignment to Function_definition

Each Date_and_person_assignment is_applied_to one or more Function_definition objects. Each Function_definition is related to zero, one, or more Date_and_person_assignment objects.

4.3.566 Date_and_person_assignment to Function_definition_relationship

Each Date_and_person_assignment is_applied_to one or more Function_definition_relationship objects. Each Function_definition_relationship is related to zero, one, or more Date_and_person_assignment objects.

4.3.567 Date_and_person_assignment to Function_interface

Each Date_and_person_assignment is_applied_to one or more Function_interface objects. Each Function_interface is related to zero, one, or more Date_and_person_assignment objects.

4.3.568 Date_and_person_assignment to Function_unit

Each Date_and_person_assignment is_applied_to one or more Function_unit objects. Each Function_unit is related to zero, one, or more Date_and_person_assignment objects.

4.3.569 Date_and_person_assignment to Function_unit_relationship

Each Date_and_person_assignment is_applied_to one or more Function_unit_relationship objects. Each Function_unit_relationship is related to zero, one, or more Date_and_person_assignment objects.

4.3.570 Date_and_person_assignment to Function_version

Each Date_and_person_assignment is_applied_to one or more Function_version objects. Each Function_version is related to zero, one, or more Date_and_person_assignment objects.

4.3.571 Date_and_person_assignment to Function_version_relationship

Each Date_and_person_assignment is_applied_to one or more Function_version_relationship objects. Each Function_version_relationship is related to zero, one, or more Date_and_person_assignment objects.

4.3.572 Date_and_person_assignment to Functional_connectivity_definition

Each Date_and_person_assignment is_applied_to one or more Functional_connectivity_definition objects. Each Functional_connectivity_definition is related to zero, one, or more Date_and_person_assignment objects.

4.3.573 Date_and_person_assignment to Functional_connectivity_definition_relationship

Each Date_and_person_assignment is_applied_to one or more Functional_connectivity_definition_relationship objects. Each Functional_connectivity_definition_relationship is related to zero, one, or more Date_and_person_assignment objects.

4.3.574 Date_and_person_assignment to Functional_unit_allocation

Each Date_and_person_assignment is_applied_to one or more Functional_unit_allocation objects. Each Functional_unit_allocation is related to zero, one, or more Date_and_person_assignment objects.

4.3.575 Date_and_person_assignment to Functionality

Each Date_and_person_assignment is_applied_to one or more Functionality objects. Each Functionality is related to zero, one, or more Date_and_person_assignment objects.

4.3.576 Date_and_person_assignment to General_classification

Each Date_and_person_assignment is_applied_to one or more General_classification objects. Each General_classification is related to zero, one, or more Date_and_person_assignment objects.

4.3.577 Date_and_person_assignment to Generic_note

Each Date_and_person_assignment is_applied_to one or more Generic_note objects. Each Generic_note is related to zero, one, or more Date_and_person_assignment objects.

4.3.578 Date_and_person_assignment to Interface

Each Date_and_person_assignment is_applied_to one or more Interface objects. Each Interface is related to zero, one, or more Date_and_person_assignment objects.

4.3.579 Date_and_person_assignment to Interface_port

Each Date_and_person_assignment is_applied_to one or more Interface_port objects. Each Interface_port is related to zero, one, or more Date_and_person_assignment objects.

4.3.580 Date_and_person_assignment to Interface_terminal

Each Date_and_person_assignment is_applied_to one or more Interface_terminal objects. Each Interface_terminal is related to zero, one, or more Date_and_person_assignment objects.

4.3.581 Date_and_person_assignment to Item

Each Date_and_person_assignment is_applied_to one or more Item objects. Each Item is related to zero, one, or more Date_and_person_assignment objects.

4.3.582 Date_and_person_assignment to Item_definition_relationship

Each Date_and_person_assignment is_applied_to one or more Item_definition_relationship objects. Each Item_definition_relationship is related to zero, one, or more Date_and_person_assignment objects.

4.3.583 Date_and_person_assignment to Item_version

Each Date_and_person_assignment is_applied_to one or more Item_version objects. Each Item_version is related to zero, one, or more Date_and_person_assignment objects.

4.3.584 Date_and_person_assignment to Item_version_relationship

Each Date_and_person_assignment is_applied_to one or more Item_version_relationship objects. Each Item_version_relationship is related to zero, one, or more Date_and_person_assignment objects.

4.3.585 Date_and_person_assignment to Location

Each Date_and_person_assignment is_applied_to one or more Location objects. Each Location is related to zero, one, or more Date_and_person_assignment objects.

4.3.586 Date_and_person_assignment to Location_relationship

Each Date_and_person_assignment is_applied_to one or more Location_relationship objects. Each Location_relationship is related to zero, one, or more Date_and_person_assignment objects.

4.3.587 Date_and_person_assignment to Marking

Each Date_and_person_assignment is_applied_to one or more Marking objects. Each Marking is related to zero, one, or more Date_and_person_assignment objects.

4.3.588 Date_and_person_assignment to Material

Each Date_and_person_assignment is_applied_to one or more Material objects. Each Material is related to zero, one, or more Date_and_person_assignment objects.

4.3.589 Date_and_person_assignment to Node

Each Date_and_person_assignment is_applied_to one or more Node objects. Each Node is related to zero, one, or more Date_and_person_assignment objects.

4.3.590 Date_and_person_assignment to Node_relationship

Each Date_and_person_assignment is_applied_to one or more Node_relationship objects. Each Node_relationship is related to zero, one, or more Date_and_person_assignment objects.

4.3.591 Date_and_person_assignment to Notification

Each Date_and_person_assignment is_applied_to one or more Notification objects. Each Notification is related to zero, one, or more Date_and_person_assignment objects.

4.3.592 Date_and_person_assignment to Notification_relationship

Each Date_and_person_assignment is_applied_to one or more Notification_relationship objects. Each Notification_relationship is related to zero, one, or more Date_and_person_assignment objects.

4.3.593 Date_and_person_assignment to Offered_function_allocation

Each Date_and_person_assignment is_applied_to one or more Offered_function_allocation objects. Each Offered_function_allocation is related to zero, one, or more Date_and_person_assignment objects.

4.3.594 Date_and_person_assignment to Organization_relationship

Each Date_and_person_assignment is_applied_to one or more Organization_relationship objects. Each Organization_relationship is related to zero, one, or more Date_and_person_assignment objects.

4.3.595 Date_and_person_assignment to Path

Each Date_and_person_assignment is_applied_to one or more Path objects. Each Path is related to zero, one, or more Date_and_person_assignment objects.

4.3.596 Date_and_person_assignment to Path_node

Each Date_and_person_assignment is_applied_to one or more Path_node objects. Each Path_node is related to zero, one, or more Date_and_person_assignment objects.

4.3.597 Date_and_person_assignment to Path_node_relationship

Each Date_and_person_assignment is_applied_to one or more Path_node_relationship objects. Each Path_node_relationship is related to zero, one, or more Date_and_person_assignment objects.

4.3.598 Date_and_person_assignment to Path_relationship

Each Date_and_person_assignment is_applied_to one or more Path_relationship objects. Each Path_relationship is related to zero, one, or more Date_and_person_assignment objects.

4.3.599 Date_and_person_assignment to Person_in_organization

Each Date_and_person_assignment is_applied_to one or more Person_in_organization objects. Each Person_in_organization is related to zero, one, or more Date_and_person_assignment objects.

4.3.600 Date_and_person_assignment to Person_in_organization - relationship

Each Date_and_person_assignment is_applied_to one or more Person_in_organization_relationship objects. Each Person_in_organization_relationship is related to zero, one, or more Date_and_person_assignment objects.

4.3.601 Date_and_person_assignment to Physical_assembly_relationship

Each Date_and_person_assignment is_applied_to one or more Physical_assembly_relationship objects. Each Physical_assembly_relationship is related to zero, one, or more Date_and_person_assignment objects.

4.3.602 Date_and_person_assignment to Physical_instance

Each Date_and_person_assignment is_applied_to one or more Physical_instance objects. Each Physical_instance is related to zero, one, or more Date_and_person_assignment objects.

4.3.603 Date_and_person_assignment to Port

Each Date_and_person_assignment is_applied_to one or more Port objects. Each Port is related to zero, one, or more Date_and_person_assignment objects.

4.3.604 Date_and_person_assignment to Port_allocation

Each Date_and_person_assignment is_applied_to one or more Port_allocation objects. Each Port_allocation is related to zero, one, or more Date_and_person_assignment objects.

4.3.605 Date_and_person_assignment to Port_association

Each Date_and_person_assignment is_applied_to one or more Port_association objects. Each Port_association is related to zero, one, or more Date_and_person_assignment objects.

4.3.606 Date_and_person_assignment to Preferred_item_allocation

Each Date_and_person_assignment is_applied_to one or more Preferred_item_allocation objects. Each Preferred_item_allocation is related to zero, one, or more Date_and_person_assignment objects.

4.3.607 Date_and_person_assignment to Preferred_item_terminal_allocation

Each Date_and_person_assignment is_applied_to one or more Preferred_item_terminal_allocation objects. Each Preferred_item_terminal_allocation is related to zero, one, or more Date_and_person_assignment objects.

4.3.608 Date_and_person_assignment to Process_variable

Each Date_and_person_assignment is_applied_to one or more Process_variable objects. Each Process_variable is related to zero, one, or more Date_and_person_assignment objects.

4.3.609 Date_and_person_assignment to Process_variable_relationship

Each Date_and_person_assignment is_applied_to one or more Process_variable_relationship objects. Each Process_variable_relationship is related to zero, one, or more Date_and_person_assignment objects.

4.3.610 Date_and_person_assignment to Product_class

Each Date_and_person_assignment is_applied_to one or more Product_class objects. Each Product_class is related to zero, one, or more Date_and_person_assignment objects.

4.3.611 Date_and_person_assignment to Product_identification

Each Date_and_person_assignment is_applied_to one or more Product_identification objects. Each Product_identification is related to zero, one, or more Date_and_person_assignment objects.

4.3.612 Date_and_person_assignment to Product_structure_relationship

Each Date_and_person_assignment is_applied_to one or more Product_structure_relationship objects. Each Product_structure_relationship is related to zero, one, or more Date_and_person_assignment objects.

4.3.613 Date_and_person_assignment to Project

Each Date_and_person_assignment is_applied_to one or more Project objects. Each Project is related to zero, one, or more Date_and_person_assignment objects.

4.3.614 Date_and_person_assignment to Requirement

Each Date_and_person_assignment is_applied_to one or more Requirement objects. Each Requirement is related to zero, one, or more Date_and_person_assignment objects.

4.3.615 Date_and_person_assignment to Requirement_document_assignment

Each Date_and_person_assignment is_applied_to one or more Requirement_document_assignment objects. Each Requirement_document_assignment is related to zero, one, or more Date_and_person_assignment objects.

4.3.616 Date_and_person_assignment to Route

Each Date_and_person_assignment is_applied_to one or more Route objects. Each Route is related to zero, one, or more Date_and_person_assignment objects.

4.3.617 Date_and_person_assignment to Route_relationship

Each Date_and_person_assignment is_applied_to one or more Route_relationship objects. Each Route_relationship is related to zero, one, or more Date_and_person_assignment objects.

4.3.618 Date_and_person_assignment to Routed_segment

Each Date_and_person_assignment is_applied_to one or more Routed_segment objects. Each Routed_segment is related to zero, one, or more Date_and_person_assignment objects.

4.3.619 Date_and_person_assignment to Section

Each Date_and_person_assignment is_applied_to one or more Section objects. Each Section is related to zero, one, or more Date_and_person_assignment objects.

4.3.620 Date_and_person_assignment to Section_end

Each Date_and_person_assignment is_applied_to one or more Section_end objects. Each Section_end is related to zero, one, or more Date_and_person_assignment objects.

4.3.621 Date_and_person_assignment to Section_interface

Each Date_and_person_assignment is_applied_to one or more Section_interface objects. Each Section_interface is related to zero, one, or more Date_and_person_assignment objects.

4.3.622 Date_and_person_assignment to Section_interface_relationship

Each Date_and_person_assignment is_applied_to one or more Section_interface_relationship objects. Each Section_interface_relationship is related to zero, one, or more Date_and_person_assignment objects.

4.3.623 Date_and_person_assignment to Section_relationship

Each Date_and_person_assignment is_applied_to one or more Section_relationship objects. Each Section_relationship is related to zero, one, or more Date_and_person_assignment objects.

4.3.624 Date_and_person_assignment to Security_classification

Each Date_and_person_assignment is_applied_to one or more Security_classification objects. Each Security_classification is related to zero, one, or more Date_and_person_assignment objects.

4.3.625 Date_and_person_assignment to Security_level

Each Date_and_person_assignment is_applied_to one or more Security_level objects. Each Security_level is related to zero, one, or more Date_and_person_assignment objects.

4.3.626 Date_and_person_assignment to Signal

Each Date_and_person_assignment is_applied_to one or more Signal objects. Each Signal is related to zero, one, or more Date_and_person_assignment objects.

4.3.627 Date_and_person_assignment to Signal_relationship

Each Date_and_person_assignment is_applied_to one or more Signal_relationship objects. Each Signal_relationship is related to zero, one, or more Date_and_person_assignment objects.

4.3.628 Date_and_person_assignment to Signal_value

Each Date_and_person_assignment is_applied_to one or more Signal_value objects. Each Signal_value is related to zero, one, or more Date_and_person_assignment objects.

4.3.629 Date_and_person_assignment to Specification

Each Date_and_person_assignment is_applied_to one or more Specification objects. Each Specification is related to zero, one, or more Date_and_person_assignment objects.

4.3.630 Date_and_person_assignment to Specification_category

Each Date_and_person_assignment is_applied_to one or more Specification_category objects. Each Specification_category is related to zero, one, or more Date_and_person_assignment objects.

4.3.631 Date_and_person_assignment to Specification_expression

Each Date_and_person_assignment is_applied_to one or more Specification_expression objects. Each Specification_expression is related to zero, one, or more Date_and_person_assignment objects.

4.3.632 Date_and_person_assignment to Specification_inclusion

Each Date_and_person_assignment is_applied_to one or more Specification_inclusion objects. Each Specification_inclusion is related to zero, one, or more Date_and_person_assignment objects.

4.3.633 Date_and_person_assignment to Technical_system

Each Date_and_person_assignment is_applied_to one or more Technical_system objects. Each Technical_system is related to zero, one, or more Date_and_person_assignment objects.

4.3.634 Date_and_person_assignment to Technical_system_relationship

Each Date_and_person_assignment is_applied_to one or more Technical_system_relationship objects. Each Technical_system_relationship is related to zero, one, or more Date_and_person_assignment objects.

4.3.635 Date_and_person_assignment to Terminal

Each Date_and_person_assignment is_applied_to one or more Terminal objects. Each Terminal is related to zero, one, or more Date_and_person_assignment objects.

4.3.636 Date_and_person_assignment to Work_order

Each Date_and_person_assignment is_applied_to one or more Work_order objects. Each Work_order is related to zero, one, or more Date_and_person_assignment objects.

4.3.637 Date_and_person_assignment to Work_request

Each Date_and_person_assignment is_applied_to one or more Work_request objects. Each Work_request is related to zero, one, or more Date_and_person_assignment objects.

4.3.638 Date_and_person_or_organization to Date_time

Each Date_and_person_or_organization refers to exactly one Date_time in the role of associated_date. Each Date_time acts as associated_date for zero, one, or more Date_and_person_or_organization objects.

4.3.639 Date_and_person_or_organization to Organization

Each Date_and_person_or_organization refers to exactly one Organization in the role of person_or_organization. Each Organization acts as person_or_organization for zero, one, or more Date_and_person_or_organization objects.

4.3.640 Date_and_person_or_organization to Person_in_organization

Each Date_and_person_or_organization refers to exactly one Person_in_organization in the role of person_or_organization. Each Person_in_organization acts as person_or_organization for zero, one, or more Date_and_person_or_organization objects.

4.3.641 Date_time_assignment to Activity

Each Date_time_assignment is_applied_to one or more Activity objects. Each Activity is related to zero, one, or more Date_time_assignment objects.

4.3.642 Date_time_assignment to Activity_element

Each Date_time_assignment is_applied_to one or more Activity_element objects. Each Activity_element is related to zero, one, or more Date_time_assignment objects.

4.3.643 Date_time_assignment to Activity_method_assignment

Each Date_time_assignment is_applied_to one or more Activity_method_assignment objects. Each Activity_method_assignment is related to zero, one, or more Date_time_assignment objects.

4.3.644 Date_time_assignment to Activity_relationship

Each Date_time_assignment is_applied_to one or more Activity_relationship objects. Each Activity_relationship is related to zero, one, or more Date_time_assignment objects.

4.3.645 Date_time_assignment to Alternate_item_relationship

Each Date_time_assignment is_applied_to one or more Alternate_item_relationship objects. Each Alternate_item_relationship is related to zero, one, or more Date_time_assignment objects.

4.3.646 Date_time_assignment to Approval_status

Each Date_time_assignment is_applied_to one or more Approval_status objects. Each Approval_status is related to zero, one, or more Date_time_assignment objects.

4.3.647 Date_time_assignment to Assembly_component_relationship

Each Date_time_assignment is_applied_to one or more Assembly_component_relationship objects. Each Assembly_component_relationship is related to zero, one, or more Date_time_assignment objects.

4.3.648 Date_time_assignment to Assembly_substitute_relationship

Each Date_time_assignment is_applied_to one or more Assembly_substitute_relationship objects. Each Assembly_substitute_relationship is related to zero, one, or more Date_time_assignment objects.

4.3.649 Date_time_assignment to Cable_pull_information

Each Date_time_assignment is_applied_to one or more Cable_pull_information objects. Each Cable_pull_information is related to zero, one, or more Date_time_assignment objects.

4.3.650 Date_time_assignment to Certification

Each Date_time_assignment is_applied_to one or more Certification objects. Each Certification is related to zero, one, or more Date_time_assignment objects.

4.3.651 Date_time_assignment to Class_category_association

Each Date_time_assignment is_applied_to one or more Class_category_association objects. Each Class_category_association is related to zero, one, or more Date_time_assignment objects.

4.3.652 Date_time_assignment to Class_condition_association

Each Date_time_assignment is_applied_to one or more Class_condition_association objects. Each Class_condition_association is related to zero, one, or more Date_time_assignment objects.

4.3.653 Date_time_assignment to Class_inclusion_association

Each Date_time_assignment is_applied_to one or more Class_inclusion_association objects. Each Class_inclusion_association is related to zero, one, or more Date_time_assignment objects.

4.3.654 Date_time_assignment to Class_specification_association

Each Date_time_assignment is_applied_to one or more Class_specification_association objects. Each Class_specification_association is related to zero, one, or more Date_time_assignment objects.

4.3.655 Date_time_assignment to Class_structure_relationship

Each Date_time_assignment is_applied_to one or more Class_structure_relationship objects. Each Class_structure_relationship is related to zero, one, or more Date_time_assignment objects.

4.3.656 Date_time_assignment to Classification_association

Each Date_time_assignment is_applied_to one or more Classification_association objects. Each Classification_association is related to zero, one, or more Date_time_assignment objects.

4.3.657 Date_time_assignment to Classification_attribute

Each Date_time_assignment is_applied_to one or more Classification_attribute objects. Each Classification_attribute is related to zero, one, or more Date_time_assignment objects.

4.3.658 Date_time_assignment to Classification_system

Each Date_time_assignment is_applied_to one or more Classification_system objects. Each Classification_system is related to zero, one, or more Date_time_assignment objects.

4.3.659 Date_time_assignment to Complex_product

Each Date_time_assignment is_applied_to one or more Complex_product objects. Each Complex_product is related to zero, one, or more Date_time_assignment objects.

4.3.660 Date_time_assignment to Complex_product_relationship

Each Date_time_assignment is_applied_to one or more Complex_product_relationship objects. Each Complex_product_relationship is related to zero, one, or more Date_time_assignment objects.

4.3.661 Date_time_assignment to Composition_relationship

Each Date_time_assignment is_applied_to one or more Composition_relationship objects. Each Composition_relationship is related to zero, one, or more Date_time_assignment objects.

4.3.662 Date_time_assignment to Configuration

Each Date_time_assignment is_applied_to one or more Configuration objects. Each Configuration is related to zero, one, or more Date_time_assignment objects.

4.3.663 Date_time_assignment to Connectivity_allocation

Each Date_time_assignment is_applied_to one or more Connectivity_allocation objects. Each Connectivity_allocation is related to zero, one, or more Date_time_assignment objects.

4.3.664 Date_time_assignment to Connectivity_definition

Each Date_time_assignment is_applied_to one or more Connectivity_definition objects. Each Connectivity_definition is related to zero, one, or more Date_time_assignment objects.

4.3.665 Date_time_assignment to Connectivity_definition_relationship

Each Date_time_assignment is_applied_to one or more Connectivity_definition_relationship objects. Each Connectivity_definition_relationship is related to zero, one, or more Date_time_assignment objects.

4.3.666 Date_time_assignment to Contract

Each Date_time_assignment is_applied_to one or more Contract objects. Each Contract is related to zero, one, or more Date_time_assignment objects.

4.3.667 Date_time_assignment to Data_element

Each Date_time_assignment is_applied_to one or more Data_element objects. Each Data_element is related to zero, one, or more Date_time_assignment objects.

4.3.668 Date_time_assignment to Data_element_association

Each Date_time_assignment is_applied_to one or more Data_element_association objects. Each Data_element_association is related to zero, one, or more Date_time_assignment objects.

4.3.669 Date_time_assignment to Data_element_definition

Each Date_time_assignment is_applied_to one or more Data_element_definition objects. Each Data_element_definition is related to zero, one, or more Date_time_assignment objects.

4.3.670 Date_time_assignment to Data_element_relationship

Each Date_time_assignment is_applied_to one or more Data_element_relationship objects. Each Data_element_relationship is related to zero, one, or more Date_time_assignment objects.

4.3.671 Date_time_assignment to Data_element_specification

Each Date_time_assignment is_applied_to one or more Data_element_specification objects. Each Data_element_specification is related to zero, one, or more Date_time_assignment objects.

4.3.672 Date_time_assignment to Date_time

Each Date_time_assignment refers to exactly one Date_time in the role of assigned_date_time. Each Date_time acts as assigned_date_time for zero, one, or more Date_time_assignment objects.

4.3.673 Date_time_assignment to Design_discipline_item_definition

Each Date_time_assignment is_applied_to one or more Design_discipline_item_definition objects. Each Design_discipline_item_definition is related to zero, one, or more Date_time_assignment objects.

4.3.674 Date_time_assignment to Device

Each Date_time_assignment is_applied_to one or more Device objects. Each Device is related to zero, one, or more Date_time_assignment objects.

4.3.675 Date_time_assignment to Device_relationship

Each Date_time_assignment is_applied_to one or more Device_relationship objects. Each Device_relationship is related to zero, one, or more Date_time_assignment objects.

4.3.676 Date_time_assignment to Document

Each Date_time_assignment is_applied_to one or more Document objects. Each Document is related to zero, one, or more Date_time_assignment objects.

4.3.677 Date_time_assignment to Document_file

Each Date_time_assignment is_applied_to one or more Document_file objects. Each Document_file is related to zero, one, or more Date_time_assignment objects.

4.3.678 Date_time_assignment to Document_file_relationship

Each Date_time_assignment is_applied_to one or more Document_file_relationship objects. Each Document_file_relationship is related to zero, one, or more Date_time_assignment objects.

4.3.679 Date_time_assignment to Document_representation

Each Date_time_assignment is_applied_to one or more Document_representation objects. Each Document_representation is related to zero, one, or more Date_time_assignment objects.

4.3.680 Date_time_assignment to Document_version

Each Date_time_assignment is_applied_to one or more Document_version objects. Each Document_version is related to zero, one, or more Date_time_assignment objects.

4.3.681 Date_time_assignment to Document_version_relationship

Each Date_time_assignment is_applied_to one or more Document_version_relationship objects. Each Document_version_relationship is related to zero, one, or more Date_time_assignment objects.

4.3.682 Date_time_assignment to Drawing

Each Date_time_assignment is_applied_to one or more Drawing objects. Each Drawing is related to zero, one, or more Date_time_assignment objects.

4.3.683 Date_time_assignment to Drawing_sequence

Each Date_time_assignment is_applied_to one or more Drawing_sequence objects. Each Drawing_sequence is related to zero, one, or more Date_time_assignment objects.

4.3.684 Date_time_assignment to Drawing_sheet

Each Date_time_assignment is_applied_to one or more Drawing_sheet objects. Each Drawing_sheet is related to zero, one, or more Date_time_assignment objects.

4.3.685 Date_time_assignment to Drawing_sheet_relationship

Each Date_time_assignment is_applied_to one or more Drawing_sheet_relationship objects. Each Drawing_sheet_relationship is related to zero, one, or more Date_time_assignment objects.

4.3.686 Date_time_assignment to Free_segment

Each Date_time_assignment is_applied_to one or more Free_segment objects. Each Free_segment is related to zero, one, or more Date_time_assignment objects.

4.3.687 Date_time_assignment to Function_definition

Each Date_time_assignment is_applied_to one or more Function_definition objects. Each Function_definition is related to zero, one, or more Date_time_assignment objects.

4.3.688 Date_time_assignment to Function_definition_relationship

Each Date_time_assignment is_applied_to one or more Function_definition_relationship objects. Each Function_definition_relationship is related to zero, one, or more Date_time_assignment objects.

4.3.689 Date_time_assignment to Function_interface

Each Date_time_assignment is_applied_to one or more Function_interface objects. Each Function_interface is related to zero, one, or more Date_time_assignment objects.

4.3.690 Date_time_assignment to Function_unit

Each Date_time_assignment is_applied_to one or more Function_unit objects. Each Function_unit is related to zero, one, or more Date_time_assignment objects.

4.3.691 Date_time_assignment to Function_unit_relationship

Each Date_time_assignment is_applied_to one or more Function_unit_relationship objects. Each Function_unit_relationship is related to zero, one, or more Date_time_assignment objects.

4.3.692 Date_time_assignment to Function_version

Each Date_time_assignment is_applied_to one or more Function_version objects. Each Function_version is related to zero, one, or more Date_time_assignment objects.

4.3.693 Date_time_assignment to Function_version_relationship

Each Date_time_assignment is_applied_to one or more Function_version_relationship objects. Each Function_version_relationship is related to zero, one, or more Date_time_assignment objects.

4.3.694 Date_time_assignment to Functional_connectivity_definition

Each Date_time_assignment is applied to one or more Functional_connectivity_definition objects. Each Functional_connectivity_definition is related to zero, one, or more Date_time_assignment objects.

4.3.695 Date_time_assignment to Functional_connectivity_definition - relationship

Each Date_time_assignment is applied to one or more Functional_connectivity_definition - relationship objects. Each Functional_connectivity_definition_relationship is related to zero, one, or more Date_time_assignment objects.

4.3.696 Date_time_assignment to Functional_unit_allocation

Each Date_time_assignment is applied to one or more Functional_unit_allocation objects. Each Functional_unit_allocation is related to zero, one, or more Date_time_assignment objects.

4.3.697 Date_time_assignment to Functionality

Each Date_time_assignment is applied to one or more Functionality objects. Each Functionality is related to zero, one, or more Date_time_assignment objects.

4.3.698 Date_time_assignment to General_classification

Each Date_time_assignment is applied to one or more General_classification objects. Each General_classification is related to zero, one, or more Date_time_assignment objects.

4.3.699 Date_time_assignment to Generic_note

Each Date_time_assignment is applied to one or more Generic_note objects. Each Generic_note is related to zero, one, or more Date_time_assignment objects.

4.3.700 Date_time_assignment to Interface

Each Date_time_assignment is applied to one or more Interface objects. Each Interface is related to zero, one, or more Date_time_assignment objects.

4.3.701 Date_time_assignment to Interface_port

Each Date_time_assignment is applied to one or more Interface_port objects. Each Interface_port is related to zero, one, or more Date_time_assignment objects.

4.3.702 Date_time_assignment to Interface_terminal

Each Date_time_assignment is applied to one or more Interface_terminal objects. Each Interface_terminal is related to zero, one, or more Date_time_assignment objects.

4.3.703 Date_time_assignment to Item

Each Date_time_assignment is_applied_to one or more Item objects. Each Item is related to zero, one, or more Date_time_assignment objects.

4.3.704 Date_time_assignment to Item_definition_relationship

Each Date_time_assignment is_applied_to one or more Item_definition_relationship objects. Each Item_definition_relationship is related to zero, one, or more Date_time_assignment objects.

4.3.705 Date_time_assignment to Item_version

Each Date_time_assignment is_applied_to one or more Item_version objects. Each Item_version is related to zero, one, or more Date_time_assignment objects.

4.3.706 Date_time_assignment to Item_version_relationship

Each Date_time_assignment is_applied_to one or more Item_version_relationship objects. Each Item_version_relationship is related to zero, one, or more Date_time_assignment objects.

4.3.707 Date_time_assignment to Location

Each Date_time_assignment is_applied_to one or more Location objects. Each Location is related to zero, one, or more Date_time_assignment objects.

4.3.708 Date_time_assignment to Location_relationship

Each Date_time_assignment is_applied_to one or more Location_relationship objects. Each Location_relationship is related to zero, one, or more Date_time_assignment objects.

4.3.709 Date_time_assignment to Marking

Each Date_time_assignment is_applied_to one or more Marking objects. Each Marking is related to zero, one, or more Date_time_assignment objects.

4.3.710 Date_time_assignment to Material

Each Date_time_assignment is_applied_to one or more Material objects. Each Material is related to zero, one, or more Date_time_assignment objects.

4.3.711 Date_time_assignment to Node

Each Date_time_assignment is_applied_to one or more Node objects. Each Node is related to zero, one, or more Date_time_assignment objects.

4.3.712 Date_time_assignment to Node_relationship

Each Date_time_assignment is_applied_to one or more Node_relationship objects. Each Node_relationship is related to zero, one, or more Date_time_assignment objects.

4.3.713 Date_time_assignment to Notification

Each Date_time_assignment is_applied_to one or more Notification objects. Each Notification is related to zero, one, or more Date_time_assignment objects.

4.3.714 Date_time_assignment to Notification_relationship

Each Date_time_assignment is_applied_to one or more Notification_relationship objects. Each Notification_relationship is related to zero, one, or more Date_time_assignment objects.

4.3.715 Date_time_assignment to Offered_function_allocation

Each Date_time_assignment is_applied_to one or more Offered_function_allocation objects. Each Offered_function_allocation is related to zero, one, or more Date_time_assignment objects.

4.3.716 Date_time_assignment to Organization_relationship

Each Date_time_assignment is_applied_to one or more Organization_relationship objects. Each Organization_relationship is related to zero, one, or more Date_time_assignment objects.

4.3.717 Date_time_assignment to Path

Each Date_time_assignment is_applied_to one or more Path objects. Each Path is related to zero, one, or more Date_time_assignment objects.

4.3.718 Date_time_assignment to Path_node

Each Date_time_assignment is_applied_to one or more Path_node objects. Each Path_node is related to zero, one, or more Date_time_assignment objects.

4.3.719 Date_time_assignment to Path_node_relationship

Each Date_time_assignment is_applied_to one or more Path_node_relationship objects. Each Path_node_relationship is related to zero, one, or more Date_time_assignment objects.

4.3.720 Date_time_assignment to Path_relationship

Each Date_time_assignment is_applied_to one or more Path_relationship objects. Each Path_relationship is related to zero, one, or more Date_time_assignment objects.

4.3.721 Date_time_assignment to Person_in_organization

Each Date_time_assignment is_applied_to one or more Person_in_organization objects. Each Person_in_organization is related to zero, one, or more Date_time_assignment objects.

4.3.722 Date_time_assignment to Person_in_organization_relationship

Each Date_time_assignment is_applied_to one or more Person_in_organization_relationship objects. Each Person_in_organization_relationship is related to zero, one, or more Date_time_assignment objects.

4.3.723 Date_time_assignment to Physical_assembly_relationship

Each Date_time_assignment is_applied_to one or more Physical_assembly_relationship objects. Each Physical_assembly_relationship is related to zero, one, or more Date_time_assignment objects.

4.3.724 Date_time_assignment to Physical_instance

Each Date_time_assignment is_applied_to one or more Physical_instance objects. Each Physical_instance is related to zero, one, or more Date_time_assignment objects.

4.3.725 Date_time_assignment to Port

Each Date_time_assignment is_applied_to one or more Port objects. Each Port is related to zero, one, or more Date_time_assignment objects.

4.3.726 Date_time_assignment to Port_allocation

Each Date_time_assignment is_applied_to one or more Port_allocation objects. Each Port_allocation is related to zero, one, or more Date_time_assignment objects.

4.3.727 Date_time_assignment to Port_association

Each Date_time_assignment is_applied_to one or more Port_association objects. Each Port_association is related to zero, one, or more Date_time_assignment objects.

4.3.728 Date_time_assignment to Preferred_item_allocation

Each Date_time_assignment is_applied_to one or more Preferred_item_allocation objects. Each Preferred_item_allocation is related to zero, one, or more Date_time_assignment objects.

4.3.729 Date_time_assignment to Preferred_item_terminal_allocation

Each Date_time_assignment is_applied_to one or more Preferred_item_terminal_allocation objects. Each Preferred_item_terminal_allocation is related to zero, one, or more Date_time_assignment objects.

4.3.730 Date_time_assignment to Process_variable

Each Date_time_assignment is_applied_to one or more Process_variable objects. Each Process_variable is related to zero, one, or more Date_time_assignment objects.

4.3.731 Date_time_assignment to Process_variable_relationship

Each Date_time_assignment is_applied_to one or more Process_variable_relationship objects. Each Process_variable_relationship is related to zero, one, or more Date_time_assignment objects.

4.3.732 Date_time_assignment to Product_class

Each Date_time_assignment is_applied_to one or more Product_class objects. Each Product_class is related to zero, one, or more Date_time_assignment objects.

4.3.733 Date_time_assignment to Product_identification

Each Date_time_assignment is_applied_to one or more Product_identification objects. Each Product_identification is related to zero, one, or more Date_time_assignment objects.

4.3.734 Date_time_assignment to Product_structure_relationship

Each Date_time_assignment is_applied_to one or more Product_structure_relationship objects. Each Product_structure_relationship is related to zero, one, or more Date_time_assignment objects.

4.3.735 Date_time_assignment to Project

Each Date_time_assignment is_applied_to one or more Project objects. Each Project is related to zero, one, or more Date_time_assignment objects.

4.3.736 Date_time_assignment to Requirement

Each Date_time_assignment is_applied_to one or more Requirement objects. Each Requirement is related to zero, one, or more Date_time_assignment objects.

4.3.737 Date_time_assignment to Requirement_document_assignment

Each Date_time_assignment is_applied_to one or more Requirement_document_assignment objects. Each Requirement_document_assignment is related to zero, one, or more Date_time_assignment objects.

4.3.738 Date_time_assignment to Route

Each Date_time_assignment is_applied_to one or more Route objects. Each Route is related to zero, one, or more Date_time_assignment objects.

4.3.739 Date_time_assignment to Route_relationship

Each Date_time_assignment is_applied_to one or more Route_relationship objects. Each Route_relationship is related to zero, one, or more Date_time_assignment objects.

4.3.740 Date_time_assignment to Routed_segment

Each Date_time_assignment is_applied_to one or more Routed_segment objects. Each Routed_segment is related to zero, one, or more Date_time_assignment objects.

4.3.741 Date_time_assignment to Section

Each Date_time_assignment is_applied_to one or more Section objects. Each Section is related to zero, one, or more Date_time_assignment objects.

4.3.742 Date_time_assignment to Section_end

Each Date_time_assignment is_applied_to one or more Section_end objects. Each Section_end is related to zero, one, or more Date_time_assignment objects.

4.3.743 Date_time_assignment to Section_interface

Each Date_time_assignment is_applied_to one or more Section_interface objects. Each Section_interface is related to zero, one, or more Date_time_assignment objects.

4.3.744 Date_time_assignment to Section_interface_relationship

Each Date_time_assignment is_applied_to one or more Section_interface_relationship objects. Each Section_interface_relationship is related to zero, one, or more Date_time_assignment objects.

4.3.745 Date_time_assignment to Section_relationship

Each Date_time_assignment is_applied_to one or more Section_relationship objects. Each Section_relationship is related to zero, one, or more Date_time_assignment objects.

4.3.746 Date_time_assignment to Security_classification

Each Date_time_assignment is_applied_to one or more Security_classification objects. Each Security_classification is related to zero, one, or more Date_time_assignment objects.

4.3.747 Date_time_assignment to Security_level

Each Date_time_assignment is_applied_to one or more Security_level objects. Each Security_level is related to zero, one, or more Date_time_assignment objects.

4.3.748 Date_time_assignment to Signal

Each Date_time_assignment is_applied_to one or more Signal objects. Each Signal is related to zero, one, or more Date_time_assignment objects.

4.3.749 Date_time_assignment to Signal_relationship

Each Date_time_assignment is_applied_to one or more Signal_relationship objects. Each Signal_relationship is related to zero, one, or more Date_time_assignment objects.

4.3.750 Date_time_assignment to Signal_value

Each Date_time_assignment is_applied_to one or more Signal_value objects. Each Signal_value is related to zero, one, or more Date_time_assignment objects.

4.3.751 Date_time_assignment to Specification

Each Date_time_assignment is_applied_to one or more Specification objects. Each Specification is related to zero, one, or more Date_time_assignment objects.

4.3.752 Date_time_assignment to Specification_category

Each Date_time_assignment is_applied_to one or more Specification_category objects. Each Specification_category is related to zero, one, or more Date_time_assignment objects.

4.3.753 Date_time_assignment to Specification_expression

Each Date_time_assignment is_applied_to one or more Specification_expression objects. Each Specification_expression is related to zero, one, or more Date_time_assignment objects.

4.3.754 Date_time_assignment to Specification_inclusion

Each Date_time_assignment is_applied_to one or more Specification_inclusion objects. Each Specification_inclusion is related to zero, one, or more Date_time_assignment objects.

4.3.755 Date_time_assignment to Technical_system

Each Date_time_assignment is_applied_to one or more Technical_system objects. Each Technical_system is related to zero, one, or more Date_time_assignment objects.

4.3.756 Date_time_assignment to Technical_system_relationship

Each Date_time_assignment is_applied_to one or more Technical_system_relationship objects. Each Technical_system_relationship is related to zero, one, or more Date_time_assignment objects.

4.3.757 Date_time_assignment to Terminal

Each Date_time_assignment is_applied_to one or more Terminal objects. Each Terminal is related to zero, one, or more Date_time_assignment objects.

4.3.758 Date_time_assignment to Work_order

Each Date_time_assignment is_applied_to one or more Work_order objects. Each Work_order is related to zero, one, or more Date_time_assignment objects.

4.3.759 Date_time_assignment to Work_request

Each Date_time_assignment is_applied_to one or more Work_request objects. Each Work_request is related to zero, one, or more Date_time_assignment objects.

4.3.760 Date_time_interval_assignment to Activity

Each Date_time_interval_assignment is_applied_to one or more Activity objects. Each Activity is related to zero, one, or more Date_time_interval_assignment objects.

4.3.761 Date_time_interval_assignment to Activity_element

Each Date_time_interval_assignment is_applied_to one or more Activity_element objects. Each Activity_element is related to zero, one, or more Date_time_interval_assignment objects.

4.3.762 Date_time_interval_assignment to Activity_method_assignment

Each Date_time_interval_assignment is_applied_to one or more Activity_method_assignment objects. Each Activity_method_assignment is related to zero, one, or more Date_time_interval_assignment objects.

4.3.763 Date_time_interval_assignment to Activity_relationship

Each Date_time_interval_assignment is_applied_to one or more Activity_relationship objects. Each Activity_relationship is related to zero, one, or more Date_time_interval_assignment objects.

4.3.764 Date_time_interval_assignment to Alternate_item_relationship

Each Date_time_interval_assignment is_applied_to one or more Alternate_item_relationship objects. Each Alternate_item_relationship is related to zero, one, or more Date_time_interval_assignment objects.

4.3.765 Date_time_interval_assignment to Approval_status

Each Date_time_interval_assignment is_applied_to one or more Approval_status objects. Each Approval_status is related to zero, one, or more Date_time_interval_assignment objects.

4.3.766 Date_time_interval_assignment to Assembly_component_relationship

Each Date_time_interval_assignment is_applied_to one or more Assembly_component_relationship objects. Each Assembly_component_relationship is related to zero, one, or more Date_time_interval_assignment objects.

4.3.767 Date_time_interval_assignment to Assembly_substitute_relationship

Each Date_time_interval_assignment is_applied_to one or more Assembly_substitute_relationship objects. Each Assembly_substitute_relationship is related to zero, one, or more Date_time_interval_assignment objects.

4.3.768 Date_time_interval_assignment to Cable_pull_information

Each Date_time_interval_assignment is_applied_to one or more Cable_pull_information objects. Each Cable_pull_information is related to zero, one, or more Date_time_interval_assignment objects.

4.3.769 Date_time_interval_assignment to Certification

Each Date_time_interval_assignment is_applied_to one or more Certification objects. Each Certification is related to zero, one, or more Date_time_interval_assignment objects.

4.3.770 Date_time_interval_assignment to Class_category_association

Each Date_time_interval_assignment is_applied_to one or more Class_category_association objects. Each Class_category_association is related to zero, one, or more Date_time_interval_assignment objects.

4.3.771 Date_time_interval_assignment to Class_condition_association

Each Date_time_interval_assignment is applied to one or more Class_condition_association objects. Each Class_condition_association is related to zero, one, or more Date_time_interval_assignment objects.

4.3.772 Date_time_interval_assignment to Class_inclusion_association

Each Date_time_interval_assignment is applied to one or more Class_inclusion_association objects. Each Class_inclusion_association is related to zero, one, or more Date_time_interval_assignment objects.

4.3.773 Date_time_interval_assignment to Class_specification_association

Each Date_time_interval_assignment is applied to one or more Class_specification_association objects. Each Class_specification_association is related to zero, one, or more Date_time_interval_assignment objects.

4.3.774 Date_time_interval_assignment to Class_structure_relationship

Each Date_time_interval_assignment is applied to one or more Class_structure_relationship objects. Each Class_structure_relationship is related to zero, one, or more Date_time_interval_assignment objects.

4.3.775 Date_time_interval_assignment to Classification_association

Each Date_time_interval_assignment is applied to one or more Classification_association objects. Each Classification_association is related to zero, one, or more Date_time_interval_assignment objects.

4.3.776 Date_time_interval_assignment to Classification_attribute

Each Date_time_interval_assignment is applied to one or more Classification_attribute objects. Each Classification_attribute is related to zero, one, or more Date_time_interval_assignment objects.

4.3.777 Date_time_interval_assignment to Classification_system

Each Date_time_interval_assignment is applied to one or more Classification_system objects. Each Classification_system is related to zero, one, or more Date_time_interval_assignment objects.

4.3.778 Date_time_interval_assignment to Complex_product

Each Date_time_interval_assignment is applied to one or more Complex_product objects. Each Complex_product is related to zero, one, or more Date_time_interval_assignment objects.

4.3.779 Date_time_interval_assignment to Complex_product_relationship

Each Date_time_interval_assignment is applied to one or more Complex_product_relationship objects. Each Complex_product_relationship is related to zero, one, or more Date_time_interval_assignment objects.

4.3.780 Date_time_interval_assignment to Composition_relationship

Each Date_time_interval_assignment is_applied_to one or more Composition_relationship objects. Each Composition_relationship is related to zero, one, or more Date_time_interval_assignment objects.

4.3.781 Date_time_interval_assignment to Configuration

Each Date_time_interval_assignment is_applied_to one or more Configuration objects. Each Configuration is related to zero, one, or more Date_time_interval_assignment objects.

4.3.782 Date_time_interval_assignment to Connectivity_allocation

Each Date_time_interval_assignment is_applied_to one or more Connectivity_allocation objects. Each Connectivity_allocation is related to zero, one, or more Date_time_interval_assignment objects.

4.3.783 Date_time_interval_assignment to Connectivity_definition

Each Date_time_interval_assignment is_applied_to one or more Connectivity_definition objects. Each Connectivity_definition is related to zero, one, or more Date_time_interval_assignment objects.

4.3.784 Date_time_interval_assignment to Connectivity_definition_relationship

Each Date_time_interval_assignment is_applied_to one or more Connectivity_definition_relationship objects. Each Connectivity_definition_relationship is related to zero, one, or more Date_time_interval_assignment objects.

4.3.785 Date_time_interval_assignment to Contract

Each Date_time_interval_assignment is_applied_to one or more Contract objects. Each Contract is related to zero, one, or more Date_time_interval_assignment objects.

4.3.786 Date_time_interval_assignment to Data_element

Each Date_time_interval_assignment is_applied_to one or more Data_element objects. Each Data_element is related to zero, one, or more Date_time_interval_assignment objects.

4.3.787 Date_time_interval_assignment to Data_element_association

Each Date_time_interval_assignment is_applied_to one or more Data_element_association objects. Each Data_element_association is related to zero, one, or more Date_time_interval_assignment objects.

4.3.788 Date_time_interval_assignment to Data_element_definition

Each Date_time_interval_assignment is_applied_to one or more Data_element_definition objects. Each Data_element_definition is related to zero, one, or more Date_time_interval_assignment objects.

4.3.789 Date_time_interval_assignment to Data_element_relationship

Each Date_time_interval_assignment is_applied_to one or more Data_element_relationship objects. Each Data_element_relationship is related to zero, one, or more Date_time_interval_assignment objects.

4.3.790 Date_time_interval_assignment to Data_element_specification

Each Date_time_interval_assignment is_applied_to one or more Data_element_specification objects. Each Data_element_specification is related to zero, one, or more Date_time_interval_assignment objects.

4.3.791 Date_time_interval_assignment to Design_discipline_item_definition

Each Date_time_interval_assignment is_applied_to one or more Design_discipline_item_definition objects. Each Design_discipline_item_definition is related to zero, one, or more Date_time_interval_assignment objects.

4.3.792 Date_time_interval_assignment to Device

Each Date_time_interval_assignment is_applied_to one or more Device objects. Each Device is related to zero, one, or more Date_time_interval_assignment objects.

4.3.793 Date_time_interval_assignment to Device_relationship

Each Date_time_interval_assignment is_applied_to one or more Device_relationship objects. Each Device_relationship is related to zero, one, or more Date_time_interval_assignment objects.

4.3.794 Date_time_interval_assignment to Document

Each Date_time_interval_assignment is_applied_to one or more Document objects. Each Document is related to zero, one, or more Date_time_interval_assignment objects.

4.3.795 Date_time_interval_assignment to Document_file

Each Date_time_interval_assignment is_applied_to one or more Document_file objects. Each Document_file is related to zero, one, or more Date_time_interval_assignment objects.

4.3.796 Date_time_interval_assignment to Document_file_relationship

Each Date_time_interval_assignment is_applied_to one or more Document_file_relationship objects. Each Document_file_relationship is related to zero, one, or more Date_time_interval_assignment objects.

4.3.797 Date_time_interval_assignment to Document_representation

Each Date_time_interval_assignment is_applied_to one or more Document_representation objects. Each Document_representation is related to zero, one, or more Date_time_interval_assignment objects.

4.3.798 Date_time_interval_assignment to Document_version

Each Date_time_interval_assignment is_applied_to one or more Document_version objects. Each Document_version is related to zero, one, or more Date_time_interval_assignment objects.

4.3.799 Date_time_interval_assignment to Document_version - relationship

Each Date_time_interval_assignment is_applied_to one or more Document_version_relationship objects. Each Document_version_relationship is related to zero, one, or more Date_time_interval_assignment objects.

4.3.800 Date_time_interval_assignment to Drawing

Each Date_time_interval_assignment is_applied_to one or more Drawing objects. Each Drawing is related to zero, one, or more Date_time_interval_assignment objects.

4.3.801 Date_time_interval_assignment to Drawing_sequence

Each Date_time_interval_assignment is_applied_to one or more Drawing_sequence objects. Each Drawing_sequence is related to zero, one, or more Date_time_interval_assignment objects.

4.3.802 Date_time_interval_assignment to Drawing_sheet

Each Date_time_interval_assignment is_applied_to one or more Drawing_sheet objects. Each Drawing_sheet is related to zero, one, or more Date_time_interval_assignment objects.

4.3.803 Date_time_interval_assignment to Drawing_sheet_relationship

Each Date_time_interval_assignment is_applied_to one or more Drawing_sheet_relationship objects. Each Drawing_sheet_relationship is related to zero, one, or more Date_time_interval_assignment objects.

4.3.804 Date_time_interval_assignment to Free_segment

Each Date_time_interval_assignment is_applied_to one or more Free_segment objects. Each Free_segment is related to zero, one, or more Date_time_interval_assignment objects.

4.3.805 Date_time_interval_assignment to Function_definition

Each Date_time_interval_assignment is_applied_to one or more Function_definition objects. Each Function_definition is related to zero, one, or more Date_time_interval_assignment objects.

4.3.806 Date_time_interval_assignment to Function_definition - relationship

Each Date_time_interval_assignment is_applied_to one or more Function_definition_relationship objects. Each Function_definition_relationship is related to zero, one, or more Date_time_interval_assignment objects.

4.3.807 Date_time_interval_assignment to Function_interface

Each Date_time_interval_assignment is_applied_to one or more Function_interface objects. Each Function_interface is related to zero, one, or more Date_time_interval_assignment objects.

4.3.808 Date_time_interval_assignment to Function_unit

Each Date_time_interval_assignment is_applied_to one or more Function_unit objects. Each Function_unit is related to zero, one, or more Date_time_interval_assignment objects.

4.3.809 Date_time_interval_assignment to Function_unit_relationship

Each Date_time_interval_assignment is_applied_to one or more Function_unit_relationship objects. Each Function_unit_relationship is related to zero, one, or more Date_time_interval_assignment objects.

4.3.810 Date_time_interval_assignment to Function_version

Each Date_time_interval_assignment is_applied_to one or more Function_version objects. Each Function_version is related to zero, one, or more Date_time_interval_assignment objects.

4.3.811 Date_time_interval_assignment to Function_version_relationship

Each Date_time_interval_assignment is_applied_to one or more Function_version_relationship objects. Each Function_version_relationship is related to zero, one, or more Date_time_interval_assignment objects.

4.3.812 Date_time_interval_assignment to Functional_connectivity_definition

Each Date_time_interval_assignment is_applied_to one or more Functional_connectivity_definition objects. Each Functional_connectivity_definition is related to zero, one, or more Date_time_interval_assignment objects.

4.3.813 Date_time_interval_assignment to Functional_connectivity_definition_relationship

Each Date_time_interval_assignment is_applied_to one or more Functional_connectivity_definition_relationship objects. Each Functional_connectivity_definition_relationship is related to zero, one, or more Date_time_interval_assignment objects.

4.3.814 Date_time_interval_assignment to Functional_unit_allocation

Each Date_time_interval_assignment is_applied_to one or more Functional_unit_allocation objects. Each Functional_unit_allocation is related to zero, one, or more Date_time_interval_assignment objects.

4.3.815 Date_time_interval_assignment to Functionality

Each Date_time_interval_assignment is_applied_to one or more Functionality objects. Each Functionality is related to zero, one, or more Date_time_interval_assignment objects.

4.3.816 Date_time_interval_assignment to General_classification

Each Date_time_interval_assignment is_applied_to one or more General_classification objects. Each General_classification is related to zero, one, or more Date_time_interval_assignment objects.

4.3.817 Date_time_interval_assignment to Generic_note

Each Date_time_interval_assignment is_applied_to one or more Generic_note objects. Each Generic_note is related to zero, one, or more Date_time_interval_assignment objects.

4.3.818 Date_time_interval_assignment to Interface

Each Date_time_interval_assignment is_applied_to one or more Interface objects. Each Interface is related to zero, one, or more Date_time_interval_assignment objects.

4.3.819 Date_time_interval_assignment to Interface_port

Each Date_time_interval_assignment is_applied_to one or more Interface_port objects. Each Interface_port is related to zero, one, or more Date_time_interval_assignment objects.

4.3.820 Date_time_interval_assignment to Interface_terminal

Each Date_time_interval_assignment is_applied_to one or more Interface_terminal objects. Each Interface_terminal is related to zero, one, or more Date_time_interval_assignment objects.

4.3.821 Date_time_interval_assignment to Interval_of_time

Each Date_time_interval_assignment refers to exactly one Interval_of_time in the role of assigned_time_interval. Each Interval_of_time acts as assigned_time_interval for zero, one, or more Date_time_interval_assignment objects.

4.3.822 Date_time_interval_assignment to Item

Each Date_time_interval_assignment is_applied_to one or more Item objects. Each Item is related to zero, one, or more Date_time_interval_assignment objects.

4.3.823 Date_time_interval_assignment to Item_definition_relationship

Each Date_time_interval_assignment is_applied_to one or more Item_definition_relationship objects. Each Item_definition_relationship is related to zero, one, or more Date_time_interval_assignment objects.

4.3.824 Date_time_interval_assignment to Item_version

Each Date_time_interval_assignment is_applied_to one or more Item_version objects. Each Item_version is related to zero, one, or more Date_time_interval_assignment objects.

4.3.825 Date_time_interval_assignment to Item_version_relationship

Each Date_time_interval_assignment is_applied_to one or more Item_version_relationship objects. Each Item_version_relationship is related to zero, one, or more Date_time_interval_assignment objects.

4.3.826 Date_time_interval_assignment to Location

Each Date_time_interval_assignment is_applied_to one or more Location objects. Each Location is related to zero, one, or more Date_time_interval_assignment objects.

4.3.827 Date_time_interval_assignment to Location_relationship

Each Date_time_interval_assignment is_applied_to one or more Location_relationship objects. Each Location_relationship is related to zero, one, or more Date_time_interval_assignment objects.

4.3.828 Date_time_interval_assignment to Marking

Each Date_time_interval_assignment is_applied_to one or more Marking objects. Each Marking is related to zero, one, or more Date_time_interval_assignment objects.

4.3.829 Date_time_interval_assignment to Material

Each Date_time_interval_assignment is_applied_to one or more Material objects. Each Material is related to zero, one, or more Date_time_interval_assignment objects.

4.3.830 Date_time_interval_assignment to Node

Each Date_time_interval_assignment is_applied_to one or more Node objects. Each Node is related to zero, one, or more Date_time_interval_assignment objects.

4.3.831 Date_time_interval_assignment to Node_relationship

Each Date_time_interval_assignment is_applied_to one or more Node_relationship objects. Each Node_relationship is related to zero, one, or more Date_time_interval_assignment objects.

4.3.832 Date_time_interval_assignment to Notification

Each Date_time_interval_assignment is_applied_to one or more Notification objects. Each Notification is related to zero, one, or more Date_time_interval_assignment objects.

4.3.833 Date_time_interval_assignment to Notification_relationship

Each Date_time_interval_assignment is_applied_to one or more Notification_relationship objects. Each Notification_relationship is related to zero, one, or more Date_time_interval_assignment objects.

4.3.834 Date_time_interval_assignment to Offered_function_allocation

Each Date_time_interval_assignment is_applied_to one or more Offered_function_allocation objects. Each Offered_function_allocation is related to zero, one, or more Date_time_interval_assignment objects.

4.3.835 Date_time_interval_assignment to Organization_relationship

Each Date_time_interval_assignment is_applied_to one or more Organization_relationship objects. Each Organization_relationship is related to zero, one, or more Date_time_interval_assignment objects.

4.3.836 Date_time_interval_assignment to Path

Each Date_time_interval_assignment is_applied_to one or more Path objects. Each Path is related to zero, one, or more Date_time_interval_assignment objects.

4.3.837 Date_time_interval_assignment to Path_node

Each Date_time_interval_assignment is_applied_to one or more Path_node objects. Each Path_node is related to zero, one, or more Date_time_interval_assignment objects.

4.3.838 Date_time_interval_assignment to Path_node_relationship

Each Date_time_interval_assignment is_applied_to one or more Path_node_relationship objects. Each Path_node_relationship is related to zero, one, or more Date_time_interval_assignment objects.

4.3.839 Date_time_interval_assignment to Path_relationship

Each Date_time_interval_assignment is_applied_to one or more Path_relationship objects. Each Path_relationship is related to zero, one, or more Date_time_interval_assignment objects.

4.3.840 Date_time_interval_assignment to Person_in_organization

Each Date_time_interval_assignment is_applied_to one or more Person_in_organization objects. Each Person_in_organization is related to zero, one, or more Date_time_interval_assignment objects.

4.3.841 Date_time_interval_assignment to Person_in_organization_relationship

Each Date_time_interval_assignment is_applied_to one or more Person_in_organization_relationship objects. Each Person_in_organization_relationship is related to zero, one, or more Date_time_interval_assignment objects.

4.3.842 Date_time_interval_assignment to Physical_assembly_- relationship

Each Date_time_interval_assignment is_applied_to one or more Physical_assembly_relationship objects. Each Physical_assembly_relationship is related to zero, one, or more Date_time_interval_assignment objects.

4.3.843 Date_time_interval_assignment to Physical_instance

Each Date_time_interval_assignment is_applied_to one or more Physical_instance objects. Each Physical_instance is related to zero, one, or more Date_time_interval_assignment objects.

4.3.844 Date_time_interval_assignment to Port

Each Date_time_interval_assignment is_applied_to one or more Port objects. Each Port is related to zero, one, or more Date_time_interval_assignment objects.

4.3.845 Date_time_interval_assignment to Port_allocation

Each Date_time_interval_assignment is_applied_to one or more Port_allocation objects. Each Port_allocation is related to zero, one, or more Date_time_interval_assignment objects.

4.3.846 Date_time_interval_assignment to Port_association

Each Date_time_interval_assignment is_applied_to one or more Port_association objects. Each Port_association is related to zero, one, or more Date_time_interval_assignment objects.

4.3.847 Date_time_interval_assignment to Preferred_item_allocation

Each Date_time_interval_assignment is_applied_to one or more Preferred_item_allocation objects. Each Preferred_item_allocation is related to zero, one, or more Date_time_interval_assignment objects.

4.3.848 Date_time_interval_assignment to Preferred_item_terminal_- allocation

Each Date_time_interval_assignment is_applied_to one or more Preferred_item_terminal_allocation objects. Each Preferred_item_terminal_allocation is related to zero, one, or more Date_time_interval_assignment objects.

4.3.849 Date_time_interval_assignment to Process_variable

Each Date_time_interval_assignment is_applied_to one or more Process_variable objects. Each Process_variable is related to zero, one, or more Date_time_interval_assignment objects.

4.3.850 Date_time_interval_assignment to Process_variable_relationship

Each Date_time_interval_assignment is applied to one or more Process_variable_relationship objects. Each Process_variable_relationship is related to zero, one, or more Date_time_interval_assignment objects.

4.3.851 Date_time_interval_assignment to Product_class

Each Date_time_interval_assignment is applied to one or more Product_class objects. Each Product_class is related to zero, one, or more Date_time_interval_assignment objects.

4.3.852 Date_time_interval_assignment to Product_identification

Each Date_time_interval_assignment is applied to one or more Product_identification objects. Each Product_identification is related to zero, one, or more Date_time_interval_assignment objects.

4.3.853 Date_time_interval_assignment to Product_structure_relationship

Each Date_time_interval_assignment is applied to one or more Product_structure_relationship objects. Each Product_structure_relationship is related to zero, one, or more Date_time_interval_assignment objects.

4.3.854 Date_time_interval_assignment to Project

Each Date_time_interval_assignment is applied to one or more Project objects. Each Project is related to zero, one, or more Date_time_interval_assignment objects.

4.3.855 Date_time_interval_assignment to Requirement

Each Date_time_interval_assignment is applied to one or more Requirement objects. Each Requirement is related to zero, one, or more Date_time_interval_assignment objects.

4.3.856 Date_time_interval_assignment to Requirement_document_assignment

Each Date_time_interval_assignment is applied to one or more Requirement_document_assignment objects. Each Requirement_document_assignment is related to zero, one, or more Date_time_interval_assignment objects.

4.3.857 Date_time_interval_assignment to Route

Each Date_time_interval_assignment is applied to one or more Route objects. Each Route is related to zero, one, or more Date_time_interval_assignment objects.

4.3.858 Date_time_interval_assignment to Route_relationship

Each Date_time_interval_assignment is applied to one or more Route_relationship objects. Each Route_relationship is related to zero, one, or more Date_time_interval_assignment objects.

4.3.859 Date_time_interval_assignment to Routed_segment

Each Date_time_interval_assignment is_applied_to one or more Routed_segment objects. Each Routed_segment is related to zero, one, or more Date_time_interval_assignment objects.

4.3.860 Date_time_interval_assignment to Section

Each Date_time_interval_assignment is_applied_to one or more Section objects. Each Section is related to zero, one, or more Date_time_interval_assignment objects.

4.3.861 Date_time_interval_assignment to Section_end

Each Date_time_interval_assignment is_applied_to one or more Section_end objects. Each Section_end is related to zero, one, or more Date_time_interval_assignment objects.

4.3.862 Date_time_interval_assignment to Section_interface

Each Date_time_interval_assignment is_applied_to one or more Section_interface objects. Each Section_interface is related to zero, one, or more Date_time_interval_assignment objects.

4.3.863 Date_time_interval_assignment to Section_interface_relationship

Each Date_time_interval_assignment is_applied_to one or more Section_interface_relationship objects. Each Section_interface_relationship is related to zero, one, or more Date_time_interval_assignment objects.

4.3.864 Date_time_interval_assignment to Section_relationship

Each Date_time_interval_assignment is_applied_to one or more Section_relationship objects. Each Section_relationship is related to zero, one, or more Date_time_interval_assignment objects.

4.3.865 Date_time_interval_assignment to Security_classification

Each Date_time_interval_assignment is_applied_to one or more Security_classification objects. Each Security_classification is related to zero, one, or more Date_time_interval_assignment objects.

4.3.866 Date_time_interval_assignment to Security_level

Each Date_time_interval_assignment is_applied_to one or more Security_level objects. Each Security_level is related to zero, one, or more Date_time_interval_assignment objects.

4.3.867 Date_time_interval_assignment to Signal

Each Date_time_interval_assignment is_applied_to one or more Signal objects. Each Signal is related to zero, one, or more Date_time_interval_assignment objects.

4.3.868 Date_time_interval_assignment to Signal_relationship

Each Date_time_interval_assignment is_applied_to one or more Signal_relationship objects. Each Signal_relationship is related to zero, one, or more Date_time_interval_assignment objects.

4.3.869 Date_time_interval_assignment to Signal_value

Each Date_time_interval_assignment is applied to one or more Signal_value objects. Each Signal_value is related to zero, one, or more Date_time_interval_assignment objects.

4.3.870 Date_time_interval_assignment to Specification

Each Date_time_interval_assignment is applied to one or more Specification objects. Each Specification is related to zero, one, or more Date_time_interval_assignment objects.

4.3.871 Date_time_interval_assignment to Specification_category

Each Date_time_interval_assignment is applied to one or more Specification_category objects. Each Specification_category is related to zero, one, or more Date_time_interval_assignment objects.

4.3.872 Date_time_interval_assignment to Specification_expression

Each Date_time_interval_assignment is applied to one or more Specification_expression objects. Each Specification_expression is related to zero, one, or more Date_time_interval_assignment objects.

4.3.873 Date_time_interval_assignment to Specification_inclusion

Each Date_time_interval_assignment is applied to one or more Specification_inclusion objects. Each Specification_inclusion is related to zero, one, or more Date_time_interval_assignment objects.

4.3.874 Date_time_interval_assignment to Technical_system

Each Date_time_interval_assignment is applied to one or more Technical_system objects. Each Technical_system is related to zero, one, or more Date_time_interval_assignment objects.

4.3.875 Date_time_interval_assignment to Technical_system_relationship

Each Date_time_interval_assignment is applied to one or more Technical_system_relationship objects. Each Technical_system_relationship is related to zero, one, or more Date_time_interval_assignment objects.

4.3.876 Date_time_interval_assignment to Terminal

Each Date_time_interval_assignment is applied to one or more Terminal objects. Each Terminal is related to zero, one, or more Date_time_interval_assignment objects.

4.3.877 Date_time_interval_assignment to Work_order

Each Date_time_interval_assignment is applied to one or more Work_order objects. Each Work_order is related to zero, one, or more Date_time_interval_assignment objects.

4.3.878 Date_time_interval_assignment to Work_request

Each Date_time_interval_assignment is applied_to one or more Work_request objects. Each Work_request is related to zero, one, or more Date_time_interval_assignment objects.

4.3.879 Design_discipline_item_definition to Application_context

Each Design_discipline_item_definition refers to zero, one, or more Application_context objects in the role of additional_context. Each Application_context acts as additional_context for zero, one, or more Design_discipline_item_definition objects.

4.3.880 Design_discipline_item_definition to Application_context

Each Design_discipline_item_definition refers to exactly one Application_context in the role of initial_context. Each Application_context acts as initial_context for zero, one, or more Design_discipline_item_definition objects.

4.3.881 Design_discipline_item_definition to Item_version

Each Design_discipline_item_definition refers to exactly one Item_version in the role of associated_item_version. Each Item_version acts as associated_item_version for zero, one, or more Design_discipline_item_definition objects.

4.3.882 Detached_representation_reference to Annotation_element

Each Detached_representation_reference refers to exactly one Annotation_element in the role of part_of. Each Annotation_element acts as part_of for zero, one, or more Detached_representation_reference objects.

4.3.883 Detached_representation_reference to Annotation_element

Each Detached_representation_reference refers to exactly one Annotation_element in the role of refers_to. Each Annotation_element acts as refers_to for zero, one, or more Detached_representation_reference objects.

4.3.884 Device to Design_discipline_item_definition

Each Device refers to exactly one Design_discipline_item_definition in the role of definition. Each Design_discipline_item_definition acts as definition for zero, one, or more Device objects.

4.3.885 Device to Object_reference_designation

Each Device refers to zero or one Object_reference_designation in the role of extended_designation. Each Object_reference_designation acts as extended_designation for zero, one, or more Device objects.

4.3.886 Device to Product_identification

Each Device refers to exactly one Product_identification in the role of definition. Each Product_identification acts as definition for zero, one, or more Device objects.

4.3.887 Device_relationship to Device

Each Device_relationship refers to exactly one Device in the role of related. Each Device acts as related for zero, one, or more Device_relationship objects.

4.3.888 Device_relationship to Device

Each Device_relationship refers to exactly one Device in the role of relating. Each Device acts as relating for zero, one, or more Device_relationship objects.

4.3.889 Diameter_dimension to Dimension_line

Each Diameter_dimension refers to exactly one Dimension_line in the role of extent. Each Dimension_line acts as extent for zero, one, or more Diameter_dimension objects.

4.3.890 Diameter_dimension to Projection_line

Each Diameter_dimension refers to zero, one, or two Projection_line objects in the role of component. Each Projection_line acts as component for zero, one, or more Diameter_dimension objects.

4.3.891 Digital_document to Digital_file

Each Digital_document refers to zero, one, or more Digital_file objects in the role of file. Each Digital_file acts as file for zero, one, or more Digital_document objects.

4.3.892 Dimension_callout to Dimension

Each Dimension_callout refers to zero or one Dimension in the role of defined_primary_dimension. Each Dimension acts as defined_primary_dimension for zero, one, or more Dimension_callout objects.

4.3.893 Dimension_callout to Dimension

Each Dimension_callout refers to zero or one Dimension in the role of defined_secondary_dimension. Each Dimension acts as defined_secondary_dimension for zero, one, or more Dimension_callout objects.

4.3.894 Dimension_line_terminator to Annotation_symbol

Each Dimension_line_terminator refers to exactly one Annotation_symbol in the role of symbol. Each Annotation_symbol acts as symbol for zero, one, or more Dimension_line_terminator objects.

4.3.895 Dimension_line_terminator to Dimension_line

Each Dimension_line_terminator refers to exactly one Dimension_line in the role of line. Each Dimension_line acts as line for zero, one, or more Dimension_line_terminator objects.

4.3.896 Dimension_sequence_pair to Dimension

Each Dimension_sequence_pair refers to exactly one Dimension in the role of predecessor. Each Dimension acts as predecessor for zero, one, or more Dimension_sequence_pair objects.

4.3.897 Dimension_sequence_pair to Dimension

Each Dimension_sequence_pair refers to exactly one Dimension in the role of successor. Each Dimension acts as successor for zero, one, or more Dimension_sequence_pair objects.

4.3.898 Directed_curve to Draughting_callout

Each Directed_curve refers to zero or one Draughting_callout in the role of directed_callout. Each Draughting_callout acts as directed_callout for zero, one, or more Directed_curve objects.

4.3.899 Direction_range to Connect_area

Each Direction_range refers to exactly one Connect_area in the role of associated_connect_area. Each Connect_area acts as associated_connect_area for zero, one, or more Direction_range objects.

4.3.900 Document to Document_designation

Each Document refers to zero or one Document_designation in the role of extended_designation. Each Document_designation acts as extended_designation for zero, one, or more Document objects.

4.3.901 Document_assignment to Activity

Each Document_assignment is_assigned_to exactly one Activity. Each Activity is related to zero, one, or more Document_assignment objects.

4.3.902 Document_assignment to Activity_element

Each Document_assignment is_assigned_to exactly one Activity_element. Each Activity_element is related to zero, one, or more Document_assignment objects.

4.3.903 Document_assignment to Activity_method

Each Document_assignment is_assigned_to exactly one Activity_method. Each Activity_method is related to zero, one, or more Document_assignment objects.

4.3.904 Document_assignment to Address

Each Document_assignment is_assigned_to exactly one Address. Each Address is related to zero, one, or more Document_assignment objects.

4.3.905 Document_assignment to Approval

Each Document_assignment is_assigned_to exactly one Approval. Each Approval is related to zero, one, or more Document_assignment objects.

4.3.906 Document_assignment to Approval_status

Each Document_assignment is_assigned_to exactly one Approval_status. Each Approval_status is related to zero, one, or more Document_assignment objects.

4.3.907 Document_assignment to Assembly_component_relationship

Each Document_assignment is_assigned_to exactly one Assembly_component_relationship. Each Assembly_component_relationship is related to zero, one, or more Document_assignment objects.

4.3.908 Document_assignment to Cable_pull_information

Each Document_assignment is_assigned_to exactly one Cable_pull_information. Each Cable_pull_information is related to zero, one, or more Document_assignment objects.

4.3.909 Document_assignment to Certification

Each Document_assignment is_assigned_to exactly one Certification. Each Certification is related to zero, one, or more Document_assignment objects.

4.3.910 Document_assignment to Class_category_association

Each Document_assignment is_assigned_to exactly one Class_category_association. Each Class_category_association is related to zero, one, or more Document_assignment objects.

4.3.911 Document_assignment to Class_condition_association

Each Document_assignment is_assigned_to exactly one Class_condition_association. Each Class_condition_association is related to zero, one, or more Document_assignment objects.

4.3.912 Document_assignment to Class_inclusion_association

Each Document_assignment is_assigned_to exactly one Class_inclusion_association. Each Class_inclusion_association is related to zero, one, or more Document_assignment objects.

4.3.913 Document_assignment to Class_specification_association

Each Document_assignment is_assigned_to exactly one Class_specification_association. Each Class_specification_association is related to zero, one, or more Document_assignment objects.

4.3.914 Document_assignment to Classification_association

Each Document_assignment is_assigned_to exactly one Classification_association. Each Classification_association is related to zero, one, or more Document_assignment objects.

4.3.915 Document_assignment to Classification_attribute

Each Document_assignment is_assigned_to exactly one Classification_attribute. Each Classification_attribute is related to zero, one, or more Document_assignment objects.

4.3.916 Document_assignment to Classification_system

Each Document_assignment is_assigned_to exactly one Classification_system. Each Classification_system is related to zero, one, or more Document_assignment objects.

4.3.917 Document_assignment to Complex_product

Each Document_assignment is_assigned_to exactly one Complex_product. Each Complex_product is related to zero, one, or more Document_assignment objects.

4.3.918 Document_assignment to Connectivity_definition

Each Document_assignment is_assigned_to exactly one Connectivity_definition. Each Connectivity_definition is related to zero, one, or more Document_assignment objects.

4.3.919 Document_assignment to Contract

Each Document_assignment is_assigned_to exactly one Contract. Each Contract is related to zero, one, or more Document_assignment objects.

4.3.920 Document_assignment to Data_element

Each Document_assignment is_assigned_to exactly one Data_element. Each Data_element is related to zero, one, or more Document_assignment objects.

4.3.921 Document_assignment to Data_element_definition

Each Document_assignment is_assigned_to exactly one Data_element_definition. Each Data_element_definition is related to zero, one, or more Document_assignment objects.

4.3.922 Document_assignment to Data_element_specification

Each Document_assignment is_assigned_to exactly one Data_element_specification. Each Data_element_specification is related to zero, one, or more Document_assignment objects.

4.3.923 Document_assignment to Descriptive_specification

Each Document_assignment is_assigned_to exactly one Descriptive_specification. Each Descriptive_specification is related to zero, one, or more Document_assignment objects.

4.3.924 Document_assignment to Design_discipline_item_definition

Each Document_assignment is_assigned_to exactly one Design_discipline_item_definition. Each Design_discipline_item_definition is related to zero, one, or more Document_assignment objects.

4.3.925 Document_assignment to Device

Each Document_assignment is_assigned_to exactly one Device. Each Device is related to zero, one, or more Document_assignment objects.

4.3.926 Document_assignment to Document

Each Document_assignment refers to exactly one Document in the role of assigned_document. Each Document acts as assigned_document for zero, one, or more Document_assignment objects.

4.3.927 Document_assignment to Document_file

Each Document_assignment refers to exactly one Document_file in the role of assigned_document. Each Document_file acts as assigned_document for zero, one, or more Document_assignment objects.

4.3.928 Document_assignment to Document_representation

Each Document_assignment refers to exactly one Document_representation in the role of assigned_document. Each Document_representation acts as assigned_document for zero, one, or more Document_assignment objects.

4.3.929 Document_assignment to Document_version

Each Document_assignment refers to exactly one Document_version in the role of assigned_document. Each Document_version acts as assigned_document for zero, one, or more Document_assignment objects.

4.3.930 Document_assignment to Drawing

Each Document_assignment is_assigned_to exactly one Drawing. Each Drawing is related to zero, one, or more Document_assignment objects.

4.3.931 Document_assignment to Drawing_sheet

Each Document_assignment is_assigned_to exactly one Drawing_sheet. Each Drawing_sheet is related to zero, one, or more Document_assignment objects.

4.3.932 Document_assignment to Drawing_view

Each Document_assignment is_assigned_to exactly one Drawing_view. Each Drawing_view is related to zero, one, or more Document_assignment objects.

4.3.933 Document_assignment to Function_definition

Each Document_assignment is_assigned_to exactly one Function_definition. Each Function_definition is related to zero, one, or more Document_assignment objects.

4.3.934 Document_assignment to Function_interface

Each Document_assignment is_assigned_to exactly one Function_interface. Each Function_interface is related to zero, one, or more Document_assignment objects.

4.3.935 Document_assignment to Function_unit

Each Document_assignment is_assigned_to exactly one Function_unit. Each Function_unit is related to zero, one, or more Document_assignment objects.

4.3.936 Document_assignment to Function_version

Each Document_assignment is_assigned_to exactly one Function_version. Each Function_version is related to zero, one, or more Document_assignment objects.

4.3.937 Document_assignment to Functional_connectivity_definition

Each Document_assignment is_assigned_to exactly one Functional_connectivity_definition. Each Functional_connectivity_definition is related to zero, one, or more Document_assignment objects.

4.3.938 Document_assignment to Functionality

Each Document_assignment is_assigned_to exactly one Functionality. Each Functionality is related to zero, one, or more Document_assignment objects.

4.3.939 Document_assignment to General_classification

Each Document_assignment is_assigned_to exactly one General_classification. Each General_classification is related to zero, one, or more Document_assignment objects.

4.3.940 Document_assignment to General_classification

Each Document_assignment is_assigned_to exactly one General_classification. Each General_classification is related to zero, one, or more Document_assignment objects.

4.3.941 Document_assignment to Generic_note

Each Document_assignment is_assigned_to exactly one Generic_note. Each Generic_note is related to zero, one, or more Document_assignment objects.

4.3.942 Document_assignment to Interface

Each Document_assignment is_assigned_to exactly one Interface. Each Interface is related to zero, one, or more Document_assignment objects.

4.3.943 Document_assignment to Interface_port

Each Document_assignment is_assigned_to exactly one Interface_port. Each Interface_port is related to zero, one, or more Document_assignment objects.

4.3.944 Document_assignment to Interface_terminal

Each Document_assignment is_assigned_to exactly one Interface_terminal. Each Interface_terminal is related to zero, one, or more Document_assignment objects.

4.3.945 Document_assignment to Item

Each Document_assignment is_assigned_to exactly one Item. Each Item is related to zero, one, or more Document_assignment objects.

4.3.946 Document_assignment to Item_definition_relationship

Each Document_assignment is_assigned_to exactly one Item_definition_relationship. Each Item_definition_relationship is related to zero, one, or more Document_assignment objects.

4.3.947 Document_assignment to Item_identification

Each Document_assignment is_assigned_to exactly one Item_identification. Each Item_identification is related to zero, one, or more Document_assignment objects.

4.3.948 Document_assignment to Item_version

Each Document_assignment is_assigned_to exactly one Item_version. Each Item_version is related to zero, one, or more Document_assignment objects.

4.3.949 Document_assignment to Location

Each Document_assignment is_assigned_to exactly one Location. Each Location is related to zero, one, or more Document_assignment objects.

4.3.950 Document_assignment to Marking

Each Document_assignment is_assigned_to exactly one Marking. Each Marking is related to zero, one, or more Document_assignment objects.

4.3.951 Document_assignment to Node

Each Document_assignment is_assigned_to exactly one Node. Each Node is related to zero, one, or more Document_assignment objects.

4.3.952 Document_assignment to Notification

Each Document_assignment is_assigned_to exactly one Notification. Each Notification is related to zero, one, or more Document_assignment objects.

4.3.953 Document_assignment to Object_designation

Each Document_assignment is_assigned_to exactly one Object_designation. Each Object_designation is related to zero, one, or more Document_assignment objects.

4.3.954 Document_assignment to Organization

Each Document_assignment is_assigned_to exactly one Organization. Each Organization is related to zero, one, or more Document_assignment objects.

4.3.955 Document_assignment to Path

Each Document_assignment is_assigned_to exactly one Path. Each Path is related to zero, one, or more Document_assignment objects.

4.3.956 Document_assignment to Path_node

Each Document_assignment is_assigned_to exactly one Path_node. Each Path_node is related to zero, one, or more Document_assignment objects.

4.3.957 Document_assignment to Person

Each Document_assignment is_assigned_to exactly one Person. Each Person is related to zero, one, or more Document_assignment objects.

4.3.958 Document_assignment to Physical_assembly_relationship

Each Document_assignment is_assigned_to exactly one Physical_assembly_relationship. Each Physical_assembly_relationship is related to zero, one, or more Document_assignment objects.

4.3.959 Document_assignment to Physical_instance

Each Document_assignment is_assigned_to exactly one Physical_instance. Each Physical_instance is related to zero, one, or more Document_assignment objects.

4.3.960 Document_assignment to Port

Each Document_assignment is_assigned_to exactly one Port. Each Port is related to zero, one, or more Document_assignment objects.

4.3.961 Document_assignment to Process_variable

Each Document_assignment is_assigned_to exactly one Process_variable. Each Process_variable is related to zero, one, or more Document_assignment objects.

4.3.962 Document_assignment to Product_class

Each Document_assignment is_assigned_to exactly one Product_class. Each Product_class is related to zero, one, or more Document_assignment objects.

4.3.963 Document_assignment to Product_identification

Each Document_assignment is_assigned_to exactly one Product_identification. Each Product_identification is related to zero, one, or more Document_assignment objects.

4.3.964 Document_assignment to Product_structure_relationship

Each Document_assignment is_assigned_to exactly one Product_structure_relationship. Each Product_structure_relationship is related to zero, one, or more Document_assignment objects.

4.3.965 Document_assignment to Project

Each Document_assignment is_assigned_to exactly one Project. Each Project is related to zero, one, or more Document_assignment objects.

4.3.966 Document_assignment to Retention_period

Each Document_assignment is_assigned_to exactly one Retention_period. Each Retention_period is related to zero, one, or more Document_assignment objects.

4.3.967 Document_assignment to Route

Each Document_assignment is_assigned_to exactly one Route. Each Route is related to zero, one, or more Document_assignment objects.

4.3.968 Document_assignment to Section

Each Document_assignment is_assigned_to exactly one Section. Each Section is related to zero, one, or more Document_assignment objects.

4.3.969 Document_assignment to Section_end

Each Document_assignment is_assigned_to exactly one Section_end. Each Section_end is related to zero, one, or more Document_assignment objects.

4.3.970 Document_assignment to Section_interface

Each Document_assignment is_assigned_to exactly one Section_interface. Each Section_interface is related to zero, one, or more Document_assignment objects.

4.3.971 Document_assignment to Security_classification

Each Document_assignment is_assigned_to exactly one Security_classification. Each Security_classification is related to zero, one, or more Document_assignment objects.

4.3.972 Document_assignment to Security_level

Each Document_assignment is_assigned_to exactly one Security_level. Each Security_level is related to zero, one, or more Document_assignment objects.

4.3.973 Document_assignment to Signal

Each Document_assignment is_assigned_to exactly one Signal. Each Signal is related to zero, one, or more Document_assignment objects.

4.3.974 Document_assignment to Signal_value

Each Document_assignment is_assigned_to exactly one Signal_value. Each Signal_value is related to zero, one, or more Document_assignment objects.

4.3.975 Document_assignment to Specification

Each Document_assignment is_assigned_to exactly one Specification. Each Specification is related to zero, one, or more Document_assignment objects.

4.3.976 Document_assignment to Specification_category

Each Document_assignment is_assigned_to exactly one Specification_category. Each Specification_category is related to zero, one, or more Document_assignment objects.

4.3.977 Document_assignment to Specification_expression

Each Document_assignment is_assigned_to exactly one Specification_expression. Each Specification_expression is related to zero, one, or more Document_assignment objects.

4.3.978 Document_assignment to Specification_inclusion

Each Document_assignment is_assigned_to exactly one Specification_inclusion. Each Specification_inclusion is related to zero, one, or more Document_assignment objects.

4.3.979 Document_assignment to Technical_system

Each Document_assignment is_assigned_to exactly one Technical_system. Each Technical_system is related to zero, one, or more Document_assignment objects.

4.3.980 Document_assignment to Terminal

Each Document_assignment is_assigned_to exactly one Terminal. Each Terminal is related to zero, one, or more Document_assignment objects.

4.3.981 Document_assignment to Work_order

Each Document_assignment is_assigned_to exactly one Work_order. Each Work_order is related to zero, one, or more Document_assignment objects.

4.3.982 Document_assignment to Work_request

Each Document_assignment is_assigned_to exactly one Work_request. Each Work_request is related to zero, one, or more Document_assignment objects.

4.3.983 Document_content_property to Language

Each Document_content_property refers to zero, one, or more Language objects in the role of languages. Each Language acts as languages for zero, one, or more Document_content_property objects.

4.3.984 Document_content_property to Numerical_value

Each Document_content_property refers to zero or one Numerical_value in the role of real_world_scale. Each Numerical_value acts as real_world_scale for zero, one, or more Document_content_property objects.

4.3.985 Document_file to Document_content_property

Each Document_file refers to zero or one Document_content_property in the role of content. Each Document_content_property acts as content for zero, one, or more Document_file objects.

4.3.986 Document_file to Document_creation_property

Each Document_file refers to zero or one Document_creation_property in the role of creation. Each Document_creation_property acts as creation for zero, one, or more Document_file objects.

4.3.987 Document_file to Document_format_property

Each Document_file refers to zero or one Document_format_property in the role of file_format. Each Document_format_property acts as file_format for zero, one, or more Document_file objects.

4.3.988 Document_file to Document_size_property

Each Document_file refers to zero or one Document_size_property in the role of size. Each Document_size_property acts as size for zero, one, or more Document_file objects.

4.3.989 Document_file to Document_type_property

Each Document_file refers to zero or one Document_type_property in the role of document_file_type. Each Document_type_property acts as document_file_type for zero, one, or more Document_file objects.

4.3.990 Document_file to External_file_id_and_location

Each Document_file refers to zero, one, or more External_file_id_and_location objects in the role of external_id_and_location. Each External_file_id_and_location acts as external_id_and_location for zero, one, or more Document_file objects.

4.3.991 Document_file_relationship to Document_file

Each Document_file_relationship refers to exactly one Document_file in the role of related. Each Document_file acts as related for zero, one, or more Document_file_relationship objects.

4.3.992 Document_file_relationship to Document_file

Each Document_file_relationship refers to exactly one Document_file in the role of relating. Each Document_file acts as relating for zero, one, or more Document_file_relationship objects.

4.3.993 Document_format_property to Rectangular_size

Each Document_format_property refers to exactly one Rectangular_size in the role of size_format. Each Rectangular_size acts as size_format for zero, one, or more Document_format_property objects.

4.3.994 Document_representation to Document_content_property

Each Document_representation refers to zero or one Document_content_property in the role of content. Each Document_content_property acts as content for zero, one, or more Document_representation objects.

4.3.995 Document_representation to Document_creation_property

Each Document_representation refers to zero or one Document_creation_property in the role of creation. Each Document_creation_property acts as creation for zero, one, or more Document_representation objects.

4.3.996 Document_representation to Document_format_property

Each Document_representation refers to zero or one Document_format_property in the role of representation_format. Each Document_format_property acts as representation_format for zero, one, or more Document_representation objects.

4.3.997 Document_representation to Document_location_property

Each Document_representation refers to zero, one, or more Document_location_property objects in the role of common_location. Each Document_location_property acts as common_location for zero, one, or more Document_representation objects.

4.3.998 Document_representation to Document_size_property

Each Document_representation refers to zero or one Document_size_property in the role of size. Each Document_size_property acts as size for zero, one, or more Document_representation objects.

4.3.999 Document_representation to Document_version

Each Document_representation refers to exactly one Document_version in the role of associated_document_version. Each Document_version acts as associated_document_version for zero, one, or more Document_representation objects.

4.3.1000 Document_size_property to Numerical_value

Each Document_size_property refers to zero or one Numerical_value in the role of file_size. Each Numerical_value acts as file_size for zero, one, or more Document_size_property objects.

4.3.1001 Document_size_property to Numerical_value

Each Document_size_property refers to zero or one Numerical_value in the role of page_count. Each Numerical_value acts as page_count for zero, one, or more Document_size_property objects.

4.3.1002 Document_structure to Document_representation

Each Document_structure refers to exactly one Document_representation in the role of related. Each Document_representation acts as related for zero, one, or more Document_structure objects.

4.3.1003 Document_structure to Document_representation

Each Document_structure refers to exactly one Document_representation in the role of relating. Each Document_representation acts as relating for zero, one, or more Document_structure objects.

4.3.1004 Document_type_property to Classification_system

Each Document_type_property refers to zero or one Classification_system in the role of used_classification_system. Each Classification_system acts as used_classification_system for zero, one, or more Document_type_property objects.

4.3.1005 Document_version to Document

Each Document_version refers to exactly one Document in the role of associated_document. Each Document acts as associated_document for zero, one, or more Document_version objects.

4.3.1006 Document_version_relationship to Document_version

Each Document_version_relationship refers to exactly one Document_version in the role of related. Each Document_version acts as related for zero, one, or more Document_version_relationship objects.

4.3.1007 Document_version_relationship to Document_version

Each Document_version_relationship refers to exactly one Document_version in the role of relating. Each Document_version acts as relating for zero, one, or more Document_version_relationship objects.

4.3.1008 Draughting_callout to Annotation_curve

Each Draughting_callout refers to one or more Annotation_curve objects in the role of components. Each Annotation_curve acts as components for zero, one, or more Draughting_callout objects.

4.3.1009 Draughting_callout to Annotation_symbol

Each Draughting_callout refers to one or more Annotation_symbol objects in the role of components. Each Annotation_symbol acts as components for zero, one, or more Draughting_callout objects.

4.3.1010 Draughting_callout to Text

Each Draughting_callout refers to one or more Text objects in the role of components. Each Text acts as components for zero, one, or more Draughting_callout objects.

4.3.1011 Draughting_model to Cartesian_coordinate_space_2d

Each Draughting_model refers to exactly one Cartesian_coordinate_space_2d in the role of coordinate_space. Each Cartesian_coordinate_space_2d acts as coordinate_space for zero, one, or more Draughting_model objects.

4.3.1012 Draughting_model to Model_placed_annotation

Each Draughting_model refers to one or more Model_placed_annotation objects in the role of element. Each Model_placed_annotation acts as element for zero, one, or more Draughting_model objects.

4.3.1013 Drawing to Document_designation

Each Drawing refers to zero or one Document_designation in the role of extended_designation. Each Document_designation acts as extended_designation for zero, one, or more Drawing objects.

4.3.1014 Drawing_assignment to Activity

Each Drawing_assignment is_assigned_to exactly one Activity. Each Activity is related to zero, one, or more Drawing_assignment objects.

4.3.1015 Drawing_assignment to Address

Each Drawing_assignment is_assigned_to exactly one Address. Each Address is related to zero, one, or more Drawing_assignment objects.

4.3.1016 Drawing_assignment to Approval

Each Drawing_assignment is_assigned_to exactly one Approval. Each Approval is related to zero, one, or more Drawing_assignment objects.

4.3.1017 Drawing_assignment to Approval_status

Each Drawing_assignment is_assigned_to exactly one Approval_status. Each Approval_status is related to zero, one, or more Drawing_assignment objects.

4.3.1018 Drawing_assignment to Cable_pull_information

Each Drawing_assignment is_assigned_to exactly one Cable_pull_information. Each Cable_pull_information is related to zero, one, or more Drawing_assignment objects.

4.3.1019 Drawing_assignment to Class_category_association

Each Drawing_assignment is_assigned_to exactly one Class_category_association. Each Class_category_association is related to zero, one, or more Drawing_assignment objects.

4.3.1020 Drawing_assignment to Class_condition_association

Each Drawing_assignment is_assigned_to exactly one Class_condition_association. Each Class_condition_association is related to zero, one, or more Drawing_assignment objects.

4.3.1021 Drawing_assignment to Class_inclusion_association

Each Drawing_assignment is_assigned_to exactly one Class_inclusion_association. Each Class_inclusion_association is related to zero, one, or more Drawing_assignment objects.

4.3.1022 Drawing_assignment to Class_specification_association

Each Drawing_assignment is_assigned_to exactly one Class_specification_association. Each Class_specification_association is related to zero, one, or more Drawing_assignment objects.

4.3.1023 Drawing_assignment to Classification_attribute

Each Drawing_assignment is_assigned_to exactly one Classification_attribute. Each Classification_attribute is related to zero, one, or more Drawing_assignment objects.

4.3.1024 Drawing_assignment to Classification_system

Each Drawing_assignment is_assigned_to exactly one Classification_system. Each Classification_system is related to zero, one, or more Drawing_assignment objects.

4.3.1025 Drawing_assignment to Complex_product

Each Drawing_assignment is_assigned_to exactly one Complex_product. Each Complex_product is related to zero, one, or more Drawing_assignment objects.

4.3.1026 Drawing_assignment to Connectivity_definition

Each Drawing_assignment is_assigned_to exactly one Connectivity_definition. Each Connectivity_definition is related to zero, one, or more Drawing_assignment objects.

4.3.1027 Drawing_assignment to Contract

Each Drawing_assignment is_assigned_to exactly one Contract. Each Contract is related to zero, one, or more Drawing_assignment objects.

4.3.1028 Drawing_assignment to Data_element

Each Drawing_assignment is_assigned_to exactly one Data_element. Each Data_element is related to zero, one, or more Drawing_assignment objects.

4.3.1029 Drawing_assignment to Data_element_definition

Each Drawing_assignment is_assigned_to exactly one Data_element_definition. Each Data_element_definition is related to zero, one, or more Drawing_assignment objects.

4.3.1030 Drawing_assignment to Data_element_specification

Each Drawing_assignment is_assigned_to exactly one Data_element_specification. Each Data_element_specification is related to zero, one, or more Drawing_assignment objects.

4.3.1031 Drawing_assignment to Design_discipline_item_definition

Each Drawing_assignment is_assigned_to exactly one Design_discipline_item_definition. Each Design_discipline_item_definition is related to zero, one, or more Drawing_assignment objects.

4.3.1032 Drawing_assignment to Device

Each Drawing_assignment is_assigned_to exactly one Device. Each Device is related to zero, one, or more Drawing_assignment objects.

4.3.1033 Drawing_assignment to Drawing

Each Drawing_assignment refers to exactly one Drawing in the role of assigned_drawing. Each Drawing acts as assigned_drawing for zero, one, or more Drawing_assignment objects.

4.3.1034 Drawing_assignment to Function_definition

Each Drawing_assignment is_assigned_to exactly one Function_definition. Each Function_definition is related to zero, one, or more Drawing_assignment objects.

4.3.1035 Drawing_assignment to Function_interface

Each Drawing_assignment is_assigned_to exactly one Function_interface. Each Function_interface is related to zero, one, or more Drawing_assignment objects.

4.3.1036 Drawing_assignment to Function_unit

Each Drawing_assignment is_assigned_to exactly one Function_unit. Each Function_unit is related to zero, one, or more Drawing_assignment objects.

4.3.1037 Drawing_assignment to Function_version

Each Drawing_assignment is_assigned_to exactly one Function_version. Each Function_version is related to zero, one, or more Drawing_assignment objects.

4.3.1038 Drawing_assignment to Functional_connectivity_definition

Each Drawing_assignment is_assigned_to exactly one Functional_connectivity_definition. Each Functional_connectivity_definition is related to zero, one, or more Drawing_assignment objects.

4.3.1039 Drawing_assignment to Functionality

Each Drawing_assignment is_assigned_to exactly one Functionality. Each Functionality is related to zero, one, or more Drawing_assignment objects.

4.3.1040 Drawing_assignment to General_classification

Each Drawing_assignment is_assigned_to exactly one General_classification. Each General_classification is related to zero, one, or more Drawing_assignment objects.

4.3.1041 Drawing_assignment to Generic_note

Each Drawing_assignment is_assigned_to exactly one Generic_note. Each Generic_note is related to zero, one, or more Drawing_assignment objects.

4.3.1042 Drawing_assignment to Interface

Each Drawing_assignment is_assigned_to exactly one Interface. Each Interface is related to zero, one, or more Drawing_assignment objects.

4.3.1043 Drawing_assignment to Interface_port

Each Drawing_assignment is_assigned_to exactly one Interface_port. Each Interface_port is related to zero, one, or more Drawing_assignment objects.

4.3.1044 Drawing_assignment to Interface_terminal

Each Drawing_assignment is_assigned_to exactly one Interface_terminal. Each Interface_terminal is related to zero, one, or more Drawing_assignment objects.

4.3.1045 Drawing_assignment to Item

Each Drawing_assignment is_assigned_to exactly one Item. Each Item is related to zero, one, or more Drawing_assignment objects.

4.3.1046 Drawing_assignment to Item_identification

Each Drawing_assignment is_assigned_to exactly one Item_identification. Each Item_identification is related to zero, one, or more Drawing_assignment objects.

4.3.1047 Drawing_assignment to Item_version

Each Drawing_assignment is_assigned_to exactly one Item_version. Each Item_version is related to zero, one, or more Drawing_assignment objects.

4.3.1048 Drawing_assignment to Location

Each Drawing_assignment is_assigned_to exactly one Location. Each Location is related to zero, one, or more Drawing_assignment objects.

4.3.1049 Drawing_assignment to Marking

Each Drawing_assignment is_assigned_to exactly one Marking. Each Marking is related to zero, one, or more Drawing_assignment objects.

4.3.1050 Drawing_assignment to Node

Each Drawing_assignment is_assigned_to exactly one Node. Each Node is related to zero, one, or more Drawing_assignment objects.

4.3.1051 Drawing_assignment to Notification

Each Drawing_assignment is_assigned_to exactly one Notification. Each Notification is related to zero, one, or more Drawing_assignment objects.

4.3.1052 Drawing_assignment to Object_designation

Each Drawing_assignment is_assigned_to exactly one Object_designation. Each Object_designation is related to zero, one, or more Drawing_assignment objects.

4.3.1053 Drawing_assignment to Organization

Each Drawing_assignment is_assigned_to exactly one Organization. Each Organization is related to zero, one, or more Drawing_assignment objects.

4.3.1054 Drawing_assignment to Path

Each Drawing_assignment is_assigned_to exactly one Path. Each Path is related to zero, one, or more Drawing_assignment objects.

4.3.1055 Drawing_assignment to Path_node

Each Drawing_assignment is_assigned_to exactly one Path_node. Each Path_node is related to zero, one, or more Drawing_assignment objects.

4.3.1056 Drawing_assignment to Person

Each Drawing_assignment is_assigned_to exactly one Person. Each Person is related to zero, one, or more Drawing_assignment objects.

4.3.1057 Drawing_assignment to Physical_assembly_relationship

Each Drawing_assignment is_assigned_to exactly one Physical_assembly_relationship. Each Physical_assembly_relationship is related to zero, one, or more Drawing_assignment objects.

4.3.1058 Drawing_assignment to Physical_instance

Each Drawing_assignment is_assigned_to exactly one Physical_instance. Each Physical_instance is related to zero, one, or more Drawing_assignment objects.

4.3.1059 Drawing_assignment to Port

Each Drawing_assignment is_assigned_to exactly one Port. Each Port is related to zero, one, or more Drawing_assignment objects.

4.3.1060 Drawing_assignment to Process_variable

Each Drawing_assignment is_assigned_to exactly one Process_variable. Each Process_variable is related to zero, one, or more Drawing_assignment objects.

4.3.1061 Drawing_assignment to Product_class

Each Drawing_assignment is_assigned_to exactly one Product_class. Each Product_class is related to zero, one, or more Drawing_assignment objects.

4.3.1062 Drawing_assignment to Product_identification

Each Drawing_assignment is_assigned_to exactly one Product_identification. Each Product_identification is related to zero, one, or more Drawing_assignment objects.

4.3.1063 Drawing_assignment to Project

Each Drawing_assignment is_assigned_to exactly one Project. Each Project is related to zero, one, or more Drawing_assignment objects.

4.3.1064 Drawing_assignment to Retention_period

Each Drawing_assignment is_assigned_to exactly one Retention_period. Each Retention_period is related to zero, one, or more Drawing_assignment objects.

4.3.1065 Drawing_assignment to Route

Each Drawing_assignment is_assigned_to exactly one Route. Each Route is related to zero, one, or more Drawing_assignment objects.

4.3.1066 Drawing_assignment to Section

Each Drawing_assignment is_assigned_to exactly one Section. Each Section is related to zero, one, or more Drawing_assignment objects.

4.3.1067 Drawing_assignment to Section_end

Each Drawing_assignment is_assigned_to exactly one Section_end. Each Section_end is related to zero, one, or more Drawing_assignment objects.

4.3.1068 Drawing_assignment to Section_interface

Each Drawing_assignment is_assigned_to exactly one Section_interface. Each Section_interface is related to zero, one, or more Drawing_assignment objects.

4.3.1069 Drawing_assignment to Security_classification

Each Drawing_assignment is_assigned_to exactly one Security_classification. Each Security_classification is related to zero, one, or more Drawing_assignment objects.

4.3.1070 Drawing_assignment to Security_level

Each Drawing_assignment is_assigned_to exactly one Security_level. Each Security_level is related to zero, one, or more Drawing_assignment objects.

4.3.1071 Drawing_assignment to Signal

Each Drawing_assignment is_assigned_to exactly one Signal. Each Signal is related to zero, one, or more Drawing_assignment objects.

4.3.1072 Drawing_assignment to Signal_value

Each Drawing_assignment is_assigned_to exactly one Signal_value. Each Signal_value is related to zero, one, or more Drawing_assignment objects.

4.3.1073 Drawing_assignment to Specification

Each Drawing_assignment is_assigned_to exactly one Specification. Each Specification is related to zero, one, or more Drawing_assignment objects.

4.3.1074 Drawing_assignment to Specification_category

Each Drawing_assignment is_assigned_to exactly one Specification_category. Each Specification_category is related to zero, one, or more Drawing_assignment objects.

4.3.1075 Drawing_assignment to Specification_expression

Each Drawing_assignment is_assigned_to exactly one Specification_expression. Each Specification_expression is related to zero, one, or more Drawing_assignment objects.

4.3.1076 Drawing_assignment to Specification_inclusion

Each Drawing_assignment is_assigned_to exactly one Specification_inclusion. Each Specification_inclusion is related to zero, one, or more Drawing_assignment objects.

4.3.1077 Drawing_assignment to Technical_system

Each Drawing_assignment is_assigned_to exactly one Technical_system. Each Technical_system is related to zero, one, or more Drawing_assignment objects.

4.3.1078 Drawing_assignment to Terminal

Each Drawing_assignment is_assigned_to exactly one Terminal. Each Terminal is related to zero, one, or more Drawing_assignment objects.

4.3.1079 Drawing_assignment to Work_order

Each Drawing_assignment is_assigned_to exactly one Work_order. Each Work_order is related to zero, one, or more Drawing_assignment objects.

4.3.1080 Drawing_assignment to Work_request

Each Drawing_assignment is_assigned_to exactly one Work_request. Each Work_request is related to zero, one, or more Drawing_assignment objects.

4.3.1081 Drawing_sequence to Drawing

Each Drawing_sequence refers to exactly one Drawing in the role of following_version. Each Drawing acts as following_version for zero, one, or more Drawing_sequence objects.

4.3.1082 Drawing_sequence to Drawing

Each Drawing_sequence refers to exactly one Drawing in the role of preceding_version. Each Drawing acts as preceding_version for zero, one, or more Drawing_sequence objects.

4.3.1083 Drawing_sheet to Cartesian_coordinate_space_2d

Each Drawing_sheet refers to exactly one Cartesian_coordinate_space_2d in the role of coordinate_space. Each Cartesian_coordinate_space_2d acts as coordinate_space for zero, one, or more Drawing_sheet objects.

4.3.1084 Drawing_sheet to Document_designation

Each Drawing_sheet refers to zero or one Document_designation in the role of extended_designation. Each Document_designation acts as extended_designation for zero, one, or more Drawing_sheet objects.

4.3.1085 Drawing_sheet to Drawing

Each Drawing_sheet refers to exactly one Drawing in the role of associated_drawing. Each Drawing acts as associated_drawing for zero, one, or more Drawing_sheet objects.

4.3.1086 Drawing_sheet to Rectangular_area

Each Drawing_sheet refers to exactly one Rectangular_area in the role of size. Each Rectangular_area acts as size for zero, one, or more Drawing_sheet objects.

4.3.1087 Drawing_sheet_relationship to Drawing_sheet

Each Drawing_sheet_relationship refers to exactly one Drawing_sheet in the role of related. Each Drawing_sheet acts as related for zero, one, or more Drawing_sheet_relationship objects.

4.3.1088 Drawing_sheet_relationship to Drawing_sheet

Each Drawing_sheet_relationship refers to exactly one Drawing_sheet in the role of relating. Each Drawing_sheet acts as relating for zero, one, or more Drawing_sheet_relationship objects.

4.3.1089 Drawing_view to Cartesian_coordinate_space_2d

Each Drawing_view refers to exactly one Cartesian_coordinate_space_2d in the role of coordinate_space. Each Cartesian_coordinate_space_2d acts as coordinate_space for zero, one, or more Drawing_view objects.

4.3.1090 Drawing_view to Drawing_sheet

Each Drawing_view refers to exactly one Drawing_sheet in the role of containing_sheet. Each Drawing_sheet acts as containing_sheet for zero, one, or more Drawing_view objects.

4.3.1091 Drawing_view to Point_2d

Each Drawing_view refers to exactly one Point_2d in the role of position. Each Point_2d acts as position for zero, one, or more Drawing_view objects.

4.3.1092 Effectivity to Date_time

Each Effectivity refers to zero or one Date_time in the role of end_definition. Each Date_time acts as end_definition for zero, one, or more Effectivity objects.

4.3.1093 Effectivity to Date_time

Each Effectivity refers to zero or one Date_time in the role of start_definition. Each Date_time acts as start_definition for zero, one, or more Effectivity objects.

4.3.1094 Effectivity to Duration

Each Effectivity refers to zero or one Duration in the role of period. Each Duration acts as period for zero, one, or more Effectivity objects.

4.3.1095 Effectivity to Event_reference

Each Effectivity refers to zero or one Event_reference in the role of end_definition. Each Event_reference acts as end_definition for zero, one, or more Effectivity objects.

4.3.1096 Effectivity to Event_reference

Each Effectivity refers to zero or one Event_reference in the role of start_definition. Each Event_reference acts as start_definition for zero, one, or more Effectivity objects.

4.3.1097 Effectivity to Organization

Each Effectivity refers to zero, one, or more Organization objects in the role of concerned_organization. Each Organization acts as concerned_organization for zero, one, or more Effectivity objects.

4.3.1098 Effectivity_assignment to Activity_relationship

Each Effectivity_assignment is_applied_to exactly one Activity_relationship. Each Activity_relationship is related to zero, one, or more Effectivity_assignment objects.

4.3.1099 Effectivity_assignment to Alternate_item_relationship

Each Effectivity_assignment is_applied_to exactly one Alternate_item_relationship. Each Alternate_item_relationship is related to zero, one, or more Effectivity_assignment objects.

4.3.1100 Effectivity_assignment to Assembly_component_relationship

Each Effectivity_assignment is_applied_to exactly one Assembly_component_relationship. Each Assembly_component_relationship is related to zero, one, or more Effectivity_assignment objects.

4.3.1101 Effectivity_assignment to Assembly_substitute_relationship

Each Effectivity_assignment is_applied_to exactly one Assembly_substitute_relationship. Each Assembly_substitute_relationship is related to zero, one, or more Effectivity_assignment objects.

4.3.1102 Effectivity_assignment to Cable_pull_information

Each Effectivity_assignment is_applied_to exactly one Cable_pull_information. Each Cable_pull_information is related to zero, one, or more Effectivity_assignment objects.

4.3.1103 Effectivity_assignment to Class_category_association

Each Effectivity_assignment is_applied_to exactly one Class_category_association. Each Class_category_association is related to zero, one, or more Effectivity_assignment objects.

4.3.1104 Effectivity_assignment to Class_condition_association

Each Effectivity_assignment is_applied_to exactly one Class_condition_association. Each Class_condition_association is related to zero, one, or more Effectivity_assignment objects.

4.3.1105 Effectivity_assignment to Class_inclusion_association

Each Effectivity_assignment is_applied_to exactly one Class_inclusion_association. Each Class_inclusion_association is related to zero, one, or more Effectivity_assignment objects.

4.3.1106 Effectivity_assignment to Class_specification_association

Each Effectivity_assignment is_applied_to exactly one Class_specification_association. Each Class_specification_association is related to zero, one, or more Effectivity_assignment objects.

4.3.1107 Effectivity_assignment to Class_structure_relationship

Each Effectivity_assignment is_applied_to exactly one Class_structure_relationship. Each Class_structure_relationship is related to zero, one, or more Effectivity_assignment objects.

4.3.1108 Effectivity_assignment to Classification_system

Each Effectivity_assignment is_applied_to exactly one Classification_system. Each Classification_system is related to zero, one, or more Effectivity_assignment objects.

4.3.1109 Effectivity_assignment to Complex_product

Each Effectivity_assignment is_applied_to exactly one Complex_product. Each Complex_product is related to zero, one, or more Effectivity_assignment objects.

4.3.1110 Effectivity_assignment to Complex_product_relationship

Each Effectivity_assignment is_applied_to exactly one Complex_product_relationship. Each Complex_product_relationship is related to zero, one, or more Effectivity_assignment objects.

4.3.1111 Effectivity_assignment to Composition_relationship

Each Effectivity_assignment is_applied_to exactly one Composition_relationship. Each Composition_relationship is related to zero, one, or more Effectivity_assignment objects.

4.3.1112 Effectivity_assignment to Configuration

Each Effectivity_assignment is_applied_to exactly one Configuration. Each Configuration is related to zero, one, or more Effectivity_assignment objects.

4.3.1113 Effectivity_assignment to Connectivity_definition

Each Effectivity_assignment is_applied_to exactly one Connectivity_definition. Each Connectivity_definition is related to zero, one, or more Effectivity_assignment objects.

4.3.1114 Effectivity_assignment to Connectivity_definition_relationship

Each Effectivity_assignment is_applied_to exactly one Connectivity_definition_relationship. Each Connectivity_definition_relationship is related to zero, one, or more Effectivity_assignment objects.

4.3.1115 Effectivity_assignment to Data_element

Each Effectivity_assignment is_applied_to exactly one Data_element. Each Data_element is related to zero, one, or more Effectivity_assignment objects.

4.3.1116 Effectivity_assignment to Data_element_association

Each Effectivity_assignment is_applied_to exactly one Data_element_association. Each Data_element_association is related to zero, one, or more Effectivity_assignment objects.

4.3.1117 Effectivity_assignment to Data_element_definition

Each Effectivity_assignment is_applied_to exactly one Data_element_definition. Each Data_element_definition is related to zero, one, or more Effectivity_assignment objects.

4.3.1118 Effectivity_assignment to Data_element_relationship

Each Effectivity_assignment is_applied_to exactly one Data_element_relationship. Each Data_element_relationship is related to zero, one, or more Effectivity_assignment objects.

4.3.1119 Effectivity_assignment to Design_discipline_item_definition

Each Effectivity_assignment is_applied_to exactly one Design_discipline_item_definition. Each Design_discipline_item_definition is related to zero, one, or more Effectivity_assignment objects.

4.3.1120 Effectivity_assignment to Device

Each Effectivity_assignment is_applied_to exactly one Device. Each Device is related to zero, one, or more Effectivity_assignment objects.

4.3.1121 Effectivity_assignment to Device_relationship

Each Effectivity_assignment is_applied_to exactly one Device_relationship. Each Device_relationship is related to zero, one, or more Effectivity_assignment objects.

4.3.1122 Effectivity_assignment to Document

Each Effectivity_assignment is_applied_to exactly one Document. Each Document is related to zero, one, or more Effectivity_assignment objects.

4.3.1123 Effectivity_assignment to Document_file

Each Effectivity_assignment is_applied_to exactly one Document_file. Each Document_file is related to zero, one, or more Effectivity_assignment objects.

4.3.1124 Effectivity_assignment to Document_file_relationship

Each Effectivity_assignment is_applied_to exactly one Document_file_relationship. Each Document_file_relationship is related to zero, one, or more Effectivity_assignment objects.

4.3.1125 Effectivity_assignment to Document_representation

Each Effectivity_assignment is_applied_to exactly one Document_representation. Each Document_representation is related to zero, one, or more Effectivity_assignment objects.

4.3.1126 Effectivity_assignment to Document_version

Each Effectivity_assignment is_applied_to exactly one Document_version. Each Document_version is related to zero, one, or more Effectivity_assignment objects.

4.3.1127 Effectivity_assignment to Document_version_relationship

Each Effectivity_assignment is_applied_to exactly one Document_version_relationship. Each Document_version_relationship is related to zero, one, or more Effectivity_assignment objects.

4.3.1128 Effectivity_assignment to Drawing

Each Effectivity_assignment is_applied_to exactly one Drawing. Each Drawing is related to zero, one, or more Effectivity_assignment objects.

4.3.1129 Effectivity_assignment to Drawing_sequence

Each Effectivity_assignment is_applied_to exactly one Drawing_sequence. Each Drawing_sequence is related to zero, one, or more Effectivity_assignment objects.

4.3.1130 Effectivity_assignment to Drawing_sheet

Each Effectivity_assignment is_applied_to exactly one Drawing_sheet. Each Drawing_sheet is related to zero, one, or more Effectivity_assignment objects.

4.3.1131 Effectivity_assignment to Drawing_sheet_relationship

Each Effectivity_assignment is_applied_to exactly one Drawing_sheet_relationship. Each Drawing_sheet_relationship is related to zero, one, or more Effectivity_assignment objects.

4.3.1132 Effectivity_assignment to Effectivity

Each Effectivity_assignment refers to exactly one Effectivity in the role of assigned_effectivity. Each Effectivity acts as assigned_effectivity for zero, one, or more Effectivity_assignment objects.

4.3.1133 Effectivity_assignment to Function_definition

Each Effectivity_assignment is_applied_to exactly one Function_definition. Each Function_definition is related to zero, one, or more Effectivity_assignment objects.

4.3.1134 Effectivity_assignment to Function_definition_relationship

Each Effectivity_assignment is_applied_to exactly one Function_definition_relationship. Each Function_definition_relationship is related to zero, one, or more Effectivity_assignment objects.

4.3.1135 Effectivity_assignment to Function_interface

Each Effectivity_assignment is_applied_to exactly one Function_interface. Each Function_interface is related to zero, one, or more Effectivity_assignment objects.

4.3.1136 Effectivity_assignment to Function_unit

Each Effectivity_assignment is_applied_to exactly one Function_unit. Each Function_unit is related to zero, one, or more Effectivity_assignment objects.

4.3.1137 Effectivity_assignment to Function_unit_relationship

Each Effectivity_assignment is_applied_to exactly one Function_unit_relationship. Each Function_unit_relationship is related to zero, one, or more Effectivity_assignment objects.

4.3.1138 Effectivity_assignment to Function_version

Each Effectivity_assignment is_applied_to exactly one Function_version. Each Function_version is related to zero, one, or more Effectivity_assignment objects.

4.3.1139 Effectivity_assignment to Function_version_relationship

Each Effectivity_assignment is_applied_to exactly one Function_version_relationship. Each Function_version_relationship is related to zero, one, or more Effectivity_assignment objects.

4.3.1140 Effectivity_assignment to Functional_connectivity_definition

Each Effectivity_assignment is_applied_to exactly one Functional_connectivity_definition. Each Functional_connectivity_definition is related to zero, one, or more Effectivity_assignment objects.

4.3.1141 Effectivity_assignment to Functional_connectivity_definition_relationship

Each Effectivity_assignment is_applied_to exactly one Functional_connectivity_definition_relationship. Each Functional_connectivity_definition_relationship is related to zero, one, or more Effectivity_assignment objects.

4.3.1142 Effectivity_assignment to Generic_note

Each Effectivity_assignment is_applied_to exactly one Generic_note. Each Generic_note is related to zero, one, or more Effectivity_assignment objects.

4.3.1143 Effectivity_assignment to Interface

Each Effectivity_assignment is_applied_to exactly one Interface. Each Interface is related to zero, one, or more Effectivity_assignment objects.

4.3.1144 Effectivity_assignment to Interface_port

Each Effectivity_assignment is_applied_to exactly one Interface_port. Each Interface_port is related to zero, one, or more Effectivity_assignment objects.

4.3.1145 Effectivity_assignment to Interface_terminal

Each Effectivity_assignment is_applied_to exactly one Interface_terminal. Each Interface_terminal is related to zero, one, or more Effectivity_assignment objects.

4.3.1146 Effectivity_assignment to Item

Each Effectivity_assignment is_applied_to exactly one Item. Each Item is related to zero, one, or more Effectivity_assignment objects.

4.3.1147 Effectivity_assignment to Item_definition_relationship

Each Effectivity_assignment is_applied_to exactly one Item_definition_relationship. Each Item_definition_relationship is related to zero, one, or more Effectivity_assignment objects.

4.3.1148 Effectivity_assignment to Item_version

Each Effectivity_assignment is_applied_to exactly one Item_version. Each Item_version is related to zero, one, or more Effectivity_assignment objects.

4.3.1149 Effectivity_assignment to Item_version_relationship

Each Effectivity_assignment is_applied_to exactly one Item_version_relationship. Each Item_version_relationship is related to zero, one, or more Effectivity_assignment objects.

4.3.1150 Effectivity_assignment to Location

Each Effectivity_assignment is_applied_to exactly one Location. Each Location is related to zero, one, or more Effectivity_assignment objects.

4.3.1151 Effectivity_assignment to Location_relationship

Each Effectivity_assignment is_applied_to exactly one Location_relationship. Each Location_relationship is related to zero, one, or more Effectivity_assignment objects.

4.3.1152 Effectivity_assignment to Marking

Each Effectivity_assignment is_applied_to exactly one Marking. Each Marking is related to zero, one, or more Effectivity_assignment objects.

4.3.1153 Effectivity_assignment to Node

Each Effectivity_assignment is_applied_to exactly one Node. Each Node is related to zero, one, or more Effectivity_assignment objects.

4.3.1154 Effectivity_assignment to Node_relationship

Each Effectivity_assignment is_applied_to exactly one Node_relationship. Each Node_relationship is related to zero, one, or more Effectivity_assignment objects.

4.3.1155 Effectivity_assignment to Notification

Each Effectivity_assignment is_applied_to exactly one Notification. Each Notification is related to zero, one, or more Effectivity_assignment objects.

4.3.1156 Effectivity_assignment to Notification_relationship

Each Effectivity_assignment is_applied_to exactly one Notification_relationship. Each Notification_relationship is related to zero, one, or more Effectivity_assignment objects.

4.3.1157 Effectivity_assignment to Path

Each Effectivity_assignment is_applied_to exactly one Path. Each Path is related to zero, one, or more Effectivity_assignment objects.

4.3.1158 Effectivity_assignment to Path_node

Each Effectivity_assignment is_applied_to exactly one Path_node. Each Path_node is related to zero, one, or more Effectivity_assignment objects.

4.3.1159 Effectivity_assignment to Path_node_relationship

Each Effectivity_assignment is_applied_to exactly one Path_node_relationship. Each Path_node_relationship is related to zero, one, or more Effectivity_assignment objects.

4.3.1160 Effectivity_assignment to Path_relationship

Each Effectivity_assignment is_applied_to exactly one Path_relationship. Each Path_relationship is related to zero, one, or more Effectivity_assignment objects.

4.3.1161 Effectivity_assignment to Physical_assembly_relationship

Each Effectivity_assignment is_applied_to exactly one Physical_assembly_relationship. Each Physical_assembly_relationship is related to zero, one, or more Effectivity_assignment objects.

4.3.1162 Effectivity_assignment to Physical_instance

Each Effectivity_assignment is_applied_to exactly one Physical_instance. Each Physical_instance is related to zero, one, or more Effectivity_assignment objects.

4.3.1163 Effectivity_assignment to Port

Each Effectivity_assignment is_applied_to exactly one Port. Each Port is related to zero, one, or more Effectivity_assignment objects.

4.3.1164 Effectivity_assignment to Process_variable

Each Effectivity_assignment is_applied_to exactly one Process_variable. Each Process_variable is related to zero, one, or more Effectivity_assignment objects.

4.3.1165 Effectivity_assignment to Process_variable_relationship

Each Effectivity_assignment is_applied_to exactly one Process_variable_relationship. Each Process_variable_relationship is related to zero, one, or more Effectivity_assignment objects.

4.3.1166 Effectivity_assignment to Product_class

Each Effectivity_assignment is_applied_to exactly one Product_class. Each Product_class is related to zero, one, or more Effectivity_assignment objects.

4.3.1167 Effectivity_assignment to Product_identification

Each Effectivity_assignment is_applied_to exactly one Product_identification. Each Product_identification is related to zero, one, or more Effectivity_assignment objects.

4.3.1168 Effectivity_assignment to Product_structure_relationship

Each Effectivity_assignment is_applied_to exactly one Product_structure_relationship. Each Product_structure_relationship is related to zero, one, or more Effectivity_assignment objects.

4.3.1169 Effectivity_assignment to Requirement

Each Effectivity_assignment is_applied_to exactly one Requirement. Each Requirement is related to zero, one, or more Effectivity_assignment objects.

4.3.1170 Effectivity_assignment to Route

Each Effectivity_assignment is_applied_to exactly one Route. Each Route is related to zero, one, or more Effectivity_assignment objects.

4.3.1171 Effectivity_assignment to Route_relationship

Each Effectivity_assignment is_applied_to exactly one Route_relationship. Each Route_relationship is related to zero, one, or more Effectivity_assignment objects.

4.3.1172 Effectivity_assignment to Section

Each Effectivity_assignment is_applied_to exactly one Section. Each Section is related to zero, one, or more Effectivity_assignment objects.

4.3.1173 Effectivity_assignment to Section_end

Each Effectivity_assignment is_applied_to exactly one Section_end. Each Section_end is related to zero, one, or more Effectivity_assignment objects.

4.3.1174 Effectivity_assignment to Section_interface

Each Effectivity_assignment is_applied_to exactly one Section_interface. Each Section_interface is related to zero, one, or more Effectivity_assignment objects.

4.3.1175 Effectivity_assignment to Section_interface_relationship

Each Effectivity_assignment is_applied_to exactly one Section_interface_relationship. Each Section_interface_relationship is related to zero, one, or more Effectivity_assignment objects.

4.3.1176 Effectivity_assignment to Section_relationship

Each Effectivity_assignment is_applied_to exactly one Section_relationship. Each Section_relationship is related to zero, one, or more Effectivity_assignment objects.

4.3.1177 Effectivity_assignment to Security_classification

Each Effectivity_assignment is_applied_to exactly one Security_classification. Each Security_classification is related to zero, one, or more Effectivity_assignment objects.

4.3.1178 Effectivity_assignment to Signal

Each Effectivity_assignment is_applied_to exactly one Signal. Each Signal is related to zero, one, or more Effectivity_assignment objects.

4.3.1179 Effectivity_assignment to Signal_relationship

Each Effectivity_assignment is_applied_to exactly one Signal_relationship. Each Signal_relationship is related to zero, one, or more Effectivity_assignment objects.

4.3.1180 Effectivity_assignment to Signal_value

Each Effectivity_assignment is_applied_to exactly one Signal_value. Each Signal_value is related to zero, one, or more Effectivity_assignment objects.

4.3.1181 Effectivity_assignment to Specification

Each Effectivity_assignment is_applied_to exactly one Specification. Each Specification is related to zero, one, or more Effectivity_assignment objects.

4.3.1182 Effectivity_assignment to Specification_category

Each Effectivity_assignment is_applied_to exactly one Specification_category. Each Specification_category is related to zero, one, or more Effectivity_assignment objects.

4.3.1183 Effectivity_assignment to Specification_expression

Each Effectivity_assignment is_applied_to exactly one Specification_expression. Each Specification_expression is related to zero, one, or more Effectivity_assignment objects.

4.3.1184 Effectivity_assignment to Specification_inclusion

Each Effectivity_assignment is_applied_to exactly one Specification_inclusion. Each Specification_inclusion is related to zero, one, or more Effectivity_assignment objects.

4.3.1185 Effectivity_assignment to Technical_system

Each Effectivity_assignment is_applied_to exactly one Technical_system. Each Technical_system is related to zero, one, or more Effectivity_assignment objects.

4.3.1186 Effectivity_assignment to Technical_system_relationship

Each Effectivity_assignment is_applied_to exactly one Technical_system_relationship. Each Technical_system_relationship is related to zero, one, or more Effectivity_assignment objects.