

INTERNATIONAL
STANDARD

ISO
10439

First edition
2002-10-15

Corrected version
2003-06-15

**Petroleum, chemical and gas service
industries — Centrifugal compressors**

Industries du pétrole, de la chimie et du gaz — Compresseurs centrifuges

STANDARDSISO.COM : Click to view the full PDF of ISO 10439:2002



Reference number
ISO 10439:2002(E)

© ISO 2002

PDF disclaimer

This PDF file may contain embedded typefaces. In accordance with Adobe's licensing policy, this file may be printed or viewed but shall not be edited unless the typefaces which are embedded are licensed to and installed on the computer performing the editing. In downloading this file, parties accept therein the responsibility of not infringing Adobe's licensing policy. The ISO Central Secretariat accepts no liability in this area.

Adobe is a trademark of Adobe Systems Incorporated.

Details of the software products used to create this PDF file can be found in the General Info relative to the file; the PDF-creation parameters were optimized for printing. Every care has been taken to ensure that the file is suitable for use by ISO member bodies. In the unlikely event that a problem relating to it is found, please inform the Central Secretariat at the address given below.

STANDARDSISO.COM : Click to view the full PDF of ISO 10439:2002

© ISO 2002

All rights reserved. Unless otherwise specified, no part of this publication may be reproduced or utilized in any form or by any means, electronic or mechanical, including photocopying and microfilm, without permission in writing from either ISO at the address below or ISO's member body in the country of the requester.

ISO copyright office
Case postale 56 • CH-1211 Geneva 20
Tel. + 41 22 749 01 11
Fax + 41 22 749 09 47
E-mail copyright@iso.org
Web www.iso.org

Printed in Switzerland

Contents

	Page
Foreword	v
Introduction.....	vi
1 Scope	1
2 Normative references	1
3 Terms and definitions	2
4 Basic design	4
4.1 General	4
4.2 Casings	7
4.3 Interstage diaphragms and inlet guide vanes	8
4.4 Casing connections	9
4.5 External forces and moments	10
4.6 Rotating elements	10
4.7 Bearings and bearing housings	11
4.8 Shaft seals	14
4.9 Dynamics	22
4.10 “Lube” oil and seal oil systems	29
4.11 Materials	29
4.12 Nameplates and rotation arrows	32
5 Accessories	33
5.1 Drivers	33
5.2 Couplings and guards	34
5.3 Mounting plates	34
5.4 Controls and instrumentation	36
5.5 Piping and appurtenances	41
5.6 Special tools	42
6 Inspection, testing and preparation for shipment	42
6.1 General	42
6.2 Inspection	43
6.3 Testing	44
6.4 Preparation for shipment	49
7 Vendor data	50
7.1 General	50
7.2 Proposals	51
7.3 Contract data	54
Annex A (informative) Typical data sheets	56
Annex B (informative) Material specifications for major component parts	81
Annex C (normative) Centrifugal compressor vendor drawing and data requirements	86
Annex D (normative) Procedure for determination of residual unbalance	95
Annex E (informative) Rotor dynamic logic diagrams	102
Annex F (informative) Centrifugal compressor nomenclature	106
Annex G (normative) Forces and moments	107
Annex H (informative) Inspector's checklist	110
Annex I (informative) Typical gas seal testing considerations	112

Annex J (informative) Application considerations for active magnetic bearings	114
Bibliography.....	117

STANDARDSISO.COM : Click to view the full PDF of ISO 10439:2002

Foreword

ISO (the International Organization for Standardization) is a worldwide federation of national standards bodies (ISO member bodies). The work of preparing International Standards is normally carried out through ISO technical committees. Each member body interested in a subject for which a technical committee has been established has the right to be represented on that committee. International organizations, governmental and non-governmental, in liaison with ISO, also take part in the work. ISO collaborates closely with the International Electrotechnical Commission (IEC) on all matters of electrotechnical standardization.

International Standards are drafted in accordance with the rules given in the ISO/IEC Directives, Part 3.

The main task of technical committees is to prepare International Standards. Draft International Standards adopted by the technical committees are circulated to the member bodies for voting. Publication as an International Standard requires approval by at least 75 % of the member bodies casting a vote.

Attention is drawn to the possibility that some of the elements of this International Standard may be the subject of patent rights. ISO shall not be held responsible for identifying any or all such patent rights.

ISO 10439 was prepared by a Joint Working Group of Technical Committees ISO/TC 118, *Compressors, pneumatic tools and pneumatic machines*, and ISO/TC 67, *Materials, equipment and offshore structures for petroleum, petrochemical and natural gas industries*, Subcommittee SC 6, *Processing equipment and systems*.

Annexes C, D and G form a normative part of this International Standard. Annexes A, B, E, F, H, I and J are for information only.

In this corrected version of ISO 10439 an oversight which saw the words "Final Draft" and its abbreviation left in the header of page 1 has been corrected.

Introduction

This International Standard is based on the sixth edition of the American Petroleum Institute standard API 617.

Users of this International Standard should be aware that further or differing requirements may be needed for individual applications. This International Standard is not intended to inhibit a vendor from offering, or the purchaser from accepting, alternative equipment or engineering solutions for the individual application. This may be particularly applicable where there is innovative or developing technology. Where an alternative is offered, the vendor should identify any variations from this International Standard and provide details.

STANDARDSISO.COM : Click to view the full PDF of ISO 10439:2002

Petroleum, chemical and gas service industries — Centrifugal compressors

1 Scope

This International Standard specifies requirements and gives recommendations for the design, materials, fabrication, inspection, testing and preparation for shipment of centrifugal compressors for use in the petroleum, chemical and gas service industries. It is not applicable to machines that develop less than 35 kPa above atmospheric pressure, nor is it applicable to packaged, integrally geared centrifugal air compressors, which are covered in ISO 10442.

NOTE In this International Standard, where practical, US customary units have been included in brackets for information.

2 Normative references

The following normative documents contain provisions which, through reference in this text, constitute provisions of this International Standard. For dated references, subsequent amendments to, or revisions of, any of these publications do not apply. However, parties to agreements based on this International Standard are encouraged to investigate the possibility of applying the most recent editions of the normative documents indicated below. For undated references, the latest edition of the normative document referred to applies. Members of ISO and IEC maintain registers of currently valid International Standards.

ISO 1940-1:—¹⁾, *Mechanical vibration — Balance quality requirements of rigid rotors — Part 1: Determination of permissible residual unbalance*

ISO 3744, *Acoustics — Determination of sound power levels of noise sources using sound pressure — Engineering method in an essentially free field over a reflecting plane*

ISO 3977-5, *Gas turbines — Procurement — Part 5: Applications for petroleum and natural gas industries*

ISO 5389, *Turbocompressors — Performance test code*

ISO 7005-2, *Metallic flanges — Part 2: Cast iron flanges*

ISO 8821, *Mechanical vibration — Balancing — Shaft and fitment key convention*

ISO 9614 (both parts), *Acoustics — Determination of sound pressure levels of noise sources using sound intensity*

ISO 10437, *Petroleum and natural gas industries — Special-purpose steam turbines for refinery service*

ISO 10438 (all parts), *Petroleum and natural gas industries — Lubrication, shaft sealing and control-oil systems*

ISO 10441, *Petroleum and natural gas industries — Flexible couplings for mechanical power transmission — Special purpose applications*

ISO 13691, *Petroleum and natural gas industries — High-speed special-purpose gear units*

1) To be published. (Revision of ISO 1940-1:1986)

IEC 60079-10, *Electrical apparatus for explosive gas atmospheres — Part 10: Classification of hazardous areas*

API²⁾ RP 550, *Manual on installation of refinery instruments and control systems*

API Std 670, *Machinery protection systems, fourth edition*

ASME³⁾ PTC 10, *Test code on compressors and exhausters*

ASTM⁴⁾ A 388/A 388M, *Standard practice for ultrasonic examination of heavy steel forgings*

ASTM A 578/A 578M, *Standard specification for straight-beam ultrasonic examination of plain and clad steel plates for special applications*

ASTM A 609/A 609M, *Standard practice for casting, carbon, low-alloy, and martensitic stainless steel, ultrasonic examination thereof*

ASTM E 94, *Standard guide for radiographic examination*

ASTM E 165, *Standard test method for liquid penetrant examination*

ASTM E 709, *Standard guide for magnetic particle examination*

ISA⁵⁾ RP 12.4, *Pressurized enclosures*

NACE⁶⁾ MR 0175, *Sulfide stress cracking resistant metallic materials for oilfield equipment*

NFPA⁷⁾ 496, *Standard for purged and pressurized enclosures for electrical equipment*

3 Terms and definitions

For the purposes of this International Standard, the following terms and definitions apply.

3.1

alarm condition

preset value of a parameter at which an alarm is actuated to warn of a condition requiring corrective action

3.2

axially split

casing or other component in which the main joint is parallel to the axis of the shaft

3.3

compressor rated point

point on the 100 % speed curve at the highest capacity of any specified operating point

NOTE The use of the word "design" in any term (such as design power, design pressure, design temperature, or design speed) should be avoided in the purchaser's specification. This terminology should be used only by the equipment designer and manufacturer.

2) American Petroleum Institute.

3) American Society of Mechanical Engineers.

4) American Society for Testing and Materials.

5) Instrument Society of America.

6) US National Association of Corrosion Engineers.

7) US National Fire Protection Association.

3.4**head**

specific compression work

3.5**inlet volume flow**

volume flow rate determined at the conditions of pressure, temperature, compressibility and gas composition, including moisture, at the compressor inlet flange

3.6**maximum allowable temperature**

maximum continuous temperature for which the manufacturer has designed the equipment (or any part to which the term is referred) when handling the specified fluid at the specified pressure

3.7**maximum allowable working pressure**

maximum continuous pressure for which the manufacturer has designed the equipment (or any part to which the term is referred) when it is operating at the maximum allowable temperature

3.8**maximum continuous speed**

highest rotational speed at which the machine is capable of continuous operation

3.9**maximum sealing pressure**

highest pressure the seals are required to seal during any specified static or operating conditions and during start-up and shutdown

3.10**minimum allowable speed**

lowest speed at which the manufacturer's design will permit continuous operation

3.11**normal operating point**

point at which usual operation is expected and optimum efficiency is desired

NOTE This will usually be the point at which the vendor certifies that performance is within the tolerances stated in this International Standard.

3.12**normal speed**

speed corresponding to the requirements of the normal operating point

3.13**100 % speed**

highest speed required for any specified operating point

3.14**pressure design code**

recognized pressure vessel standard specified or agreed by the purchaser (e.g. ASME VIII)

3.15**radially split**

casing or other component in which the main joint is perpendicular to the axis of the shaft

3.16**stability**

difference in inlet volume flow (as percentage of rated inlet volume flow) between the rated inlet volume flow and the surge point at rated speed

3.17

settling out pressure

pressure of the compressor system when the compressor is shut down

3.18

shutdown condition

preset value of a parameter requiring automatic or manual shutdown of the system

3.19

trip speed

speed at which the independent emergency overspeed device operates to shut down a prime mover

NOTE For constant speed motor drivers, this is the speed corresponding to the synchronous speed of the motor at the maximum frequency of the electrical supply.

3.20

turndown

percentage of change in inlet volume flow (referred to rated inlet volume flow) between the rated inlet volume flow and the surge point inlet volume flow at the rated head, when the unit is operating at rated suction temperature and gas composition

3.21

unit responsibility

responsibility for coordinating the technical aspects of the equipment train and all auxiliary systems

4 Basic design

4.1 General

4.1.1 A bullet (•) at the beginning of a clause indicates that the purchaser is required to make a decision or provide information. This information should be indicated on the data sheets (see annex A).

4.1.2 The equipment (including auxiliaries) covered by this International Standard shall be designed and constructed for a minimum service life of 20 years and at least 3 years of uninterrupted operation.

4.1.3 Unless otherwise specified, the compressor vendor shall assume unit responsibility.

4.1.4 The compressor shall be designed to deliver required head and capacity at the normal operating point without negative tolerance. The input power at the above condition shall not exceed 104 % of the predicted value for this point.

NOTE See the optional performance test criteria in 6.3.6.2 and handling of excess head for constant speed drivers.

4.1.5 The head versus capacity characteristic curve (see Figure 1) shall rise continuously from the rated point to the predicted surge. The compressor, without the use of a bypass, shall be suitable for continuous operation at any capacity at least 10 % greater than the predicted approximate surge capacity shown in the proposal.

4.1.6 Cooling water systems, if required, shall be designed for the conditions specified in Table 1 unless otherwise specified. Provision shall be made for complete venting and draining of the system.

The vendor shall notify the purchaser if the criteria for minimum temperature rise and velocity over heat exchange surfaces result in a conflict. The criterion for velocity overheat exchange surfaces is intended to minimize the use of cooling water. The purchaser shall approve the final selection.

4.1.7 The arrangement of the equipment, including piping and auxiliaries, shall be developed jointly by the purchaser and the vendor. The arrangement shall provide adequate clearance areas and safe access for operation and maintenance.

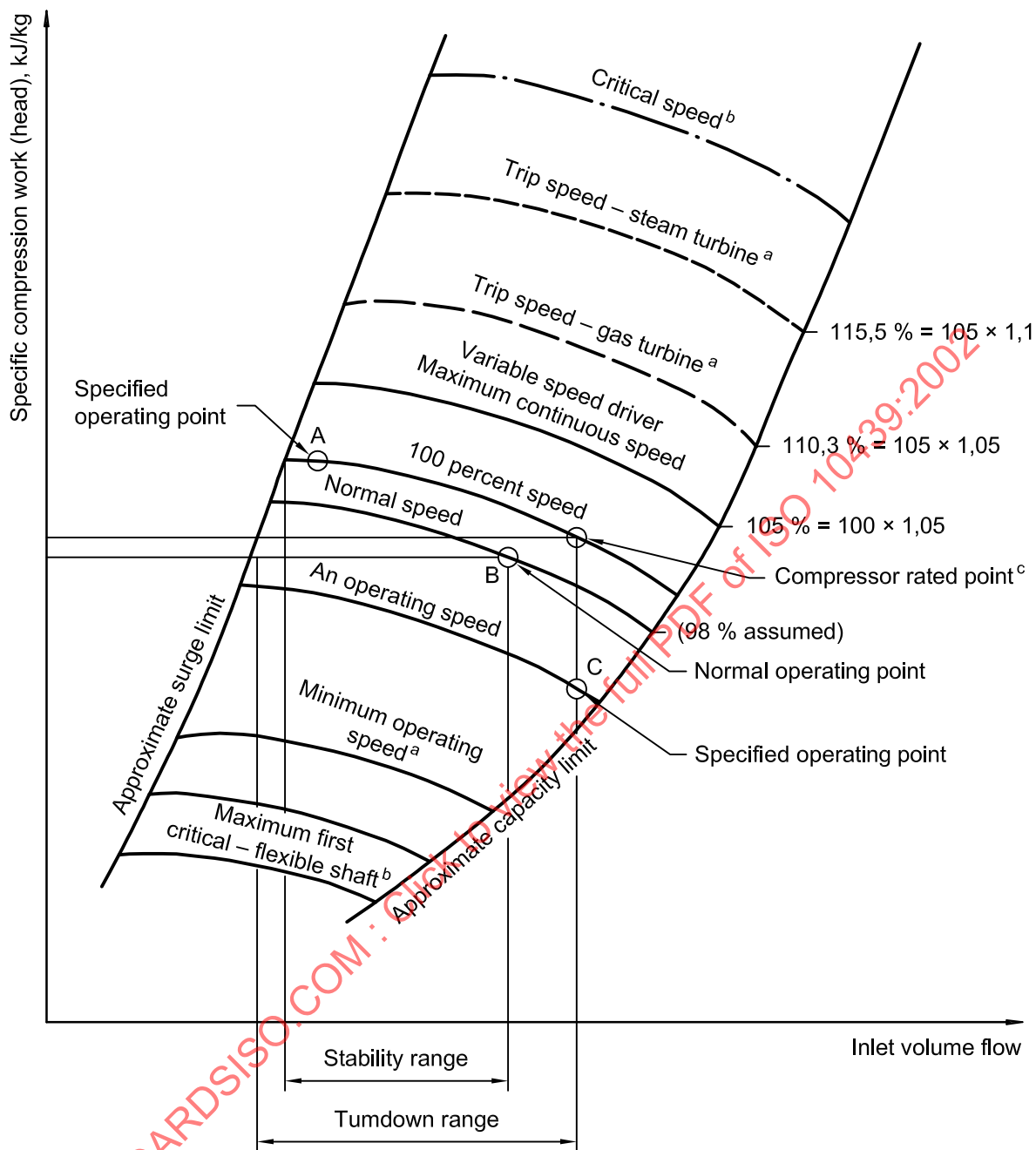

The head versus capacity curve at 100 % speed shall extend to at least 115 % capacity of the CRP. Head versus capacity curves at other speeds shall be extended to equivalent capacity at each speed. For example, the head versus capacity curve at 105 % speed shall be extended to 1,05 times 1,15 times capacity of the CRP; the head versus capacity curve at 90 % speed shall be extended to 0,9 times 1,15 times capacity at the CRP; and so on. These points define the "approximate capacity limit" curve.

Except where specific numerical relationships are stated, the relative values implied in this figure are assumed values for illustration only.

The 100 % speed is determined from the operating point requiring the highest head — point A in the illustration.

The compressor rated point (CRP) is the intersection on the 100 % speed line corresponding to the highest flow of any operating point — point C in the illustration.

^a Refer to the applicable standard for the compressor driver (e.g. ISO 10437 or ISO 3977-5) for trip speed and minimum operating speed limits.

^b See 4.9 for allowable margins of critical speeds to operating speeds.

^c The maximum continuous speed shall be 105 % for variable speed drivers. The maximum continuous speed shall be the speed corresponding to the synchronous speed of the motor.

Figure 1 — Illustration of terms

Table 1 — Cooling water systems — Design requirements

Velocity over heat exchange surfaces	1,5 m/s to 2,5 m/s (5 ft/s to 8 ft/s)
Maximum allowable gauge working pressure	≥ 500 kPa (75 psi)
Test gauge pressure	≥ 750 kPa (110 psi)
Maximum inlet temperature	30 °C (90 °F)
Maximum temperature rise	20 K (35 °F)
Fouling factor on water side	0,35 m ² K/kW (0,002 h.ft ² °F/Btu)
Maximum pressure drop	100 kPa (15 psi)
Maximum outlet temperature	50 °C (120 °F)
Minimum temperature rise	10 K (20 °F)
Shell corrosion allowance	3,0 mm (1/8 in)

4.1.8 All equipment shall be designed to permit rapid and economical maintenance. Major parts such as casing components and bearings housings shall be designed and manufactured to ensure accurate alignment on reassembly. This may be accomplished by the use of shouldering, cylindrical dowels or keys.

4.1.9 The inner casing of radially split barrel type compressors shall be designed for easy withdrawal from the outer shell and easy disassembly for inspection or replacement of parts.

- **4.1.10** The equipment, including all auxiliaries, shall be suitable for operation under the environmental conditions specified by the purchaser. These conditions shall include whether the installation is indoors (heated or unheated) or outdoors (with or without a roof), maximum and minimum temperatures, unusual humidity, and dusty or corrosive conditions. For the purchaser's guidance, the vendor shall list in the proposal any special protection that the purchaser is required to supply.

4.1.11 Control of the sound pressure level (SPL) of all equipment furnished shall be a joint effort of the purchaser and the vendor. The equipment furnished by the vendor shall conform to the maximum allowable sound pressure level specified by the purchaser.

- **4.1.12** The purchaser shall advise the vendor of any requirements for liquid injection.

4.1.13 Equipment shall be designed to run without damage to the trip speed and the maximum allowable working pressure.

4.1.14 The machine and its driver shall perform on the test stand and on their permanent foundation within the specified acceptance criteria. After installation, the performance of the combined units shall be the joint responsibility of the purchaser and the vendor having unit responsibility.

4.1.15 Many factors (such as piping loads, alignment at operating conditions, supporting structure, handling during shipment, and handling and assembly at site) may adversely affect site performance. To minimize the influence of these factors, the vendor shall review and comment on the purchaser's piping and foundation drawings. If specified, the vendor's representative shall

- a) observe a check of the piping performed by parting the flanges,
- b) check alignment at the operating temperature, and
- c) be present during the initial alignment check.

- **4.1.16** Motors and all other electrical components and installations shall be suitable for the area classification (zone) specified by the purchaser on the data sheets (see annex A), shall meet the requirements of IEC 60079-10 and shall comply with applicable local codes and regulations specified by the purchaser.

4.1.17 Spare parts for the compressor and all furnished auxiliaries shall meet all the criteria of this International Standard.

- **4.1.18** If specified, the compressor or compressors shall be suitable for field running on air. Performance parameters, including any required precautions, shall be mutually agreed upon by the purchaser and the vendor.

4.1.19 A guide to centrifugal compressor nomenclature is given in annex F.

- **4.1.20** The pressure design code shall be specified or agreed by the purchaser.

Pressure components shall comply with the pressure design code and the supplemental requirements given in this International Standard.

- **4.1.21** The purchaser and the vendor shall agree on the measures to be taken in order to comply with governmental regulations, ordinances or rules that are applicable to the equipment.

4.2 Casings

4.2.1 The thickness of the casing shall be suitable for the maximum allowable working and test pressures and shall include at least a 3 mm corrosion allowance. The thickness of the casing shall not be less than that calculated in accordance with the pressure design code.

4.2.2 The equipment feet shall be provided with vertical jackscrews and shall be drilled with pilot holes that are accessible for use in final doweling.

4.2.3 Supports and alignment bolts shall be rigid enough to permit the machine to be moved by the use of its lateral and axial jackscrews.

- **4.2.4** The maximum allowable working pressure of the casing shall be at least equal to the specified relief valve setting; if a relief valve setting is not specified or if a relief valve is not installed, the maximum allowable working pressure shall be at least 1,25 times the maximum specified discharge pressure.

NOTE System protection is normally provided by the purchaser.

4.2.5 Casings designed for more than one maximum allowable pressure level (split-pressure-level casings) are not permitted unless specifically approved by the purchaser, and if so, the vendor shall define the physical limits and the maximum allowable working pressure of each part of the casing.

4.2.6 Each axially split casing shall be sufficiently rigid to allow removal and replacement of its upper half without disturbing rotor-to-casing running clearances and bearing alignment.

4.2.7 Casings shall be made of steel for the following:

- air or non-flammable gas at a maximum allowable gauge working pressure above 2 500 kPa (360 psi);
- air or non-flammable gas at a calculated discharge temperature that is over 260 °C (500 °F) at maximum continuous speed at any point within the operating range;
- flammable or toxic gas.

4.2.8 Cast iron or other materials of construction may be offered for operating conditions other than those specified in 4.2.7.

4.2.9 Unless otherwise specified, casings shall be radially split if the partial pressure of hydrogen (at maximum allowable gauge working pressure) exceeds 1 400 kPa (200 psi).

NOTE The partial pressure of hydrogen is calculated by multiplying the highest specified mole (volume) percent of hydrogen by the maximum allowable working pressure.

4.2.10 Axially split casings shall use a metal-to-metal joint (with a suitable joint compound) that is tightly maintained by suitable bolting. Gaskets (including string type) shall not be used on the axial joint. O-rings with ring grooves machined into the flange facing of an axially split casing joint may be used with the purchaser's approval. If

gasketed joints are used between the end covers and the cylinder of radially split casings, they shall be securely maintained by confining the gaskets. Gasket materials shall be suitable for all specified service conditions.

4.2.11 Jackscrews, guide rods and cylindrical casing alignment dowels shall be provided to facilitate disassembly and reassembly. If jackscrews are used as a means of parting contacting faces, one of the faces shall be relieved (counter-bored or recessed) to prevent a leaking joint or an improper fit caused by marring of the face. Guide rods shall be of sufficient length to prevent damage to the internals or casing studs from the casing during disassembly and reassembly. Lifting lugs or eyebolts shall be provided for lifting only the top half of the casing. Methods of lifting the assembled machine shall be specified by the vendor.

4.2.12 The use of threaded holes in pressure parts shall be minimized. To prevent leakage in pressure sections of casings, metal equal in thickness to at least half the nominal bolt diameter, in addition to the allowance for corrosion, shall be left around and below the bottom of drilled and threaded holes. The depth of threaded holes shall be at least 1,5 times the stud diameter.

4.2.13 The sealing of stud clearance holes to prevent leakage is not permitted.

4.2.14 The machined finish of the compressor mounting surfaces shall be 3,2 μm to 6,4 μm (125 micro-inches to 250 micro-inches) arithmetical average roughness (R_a). Hold-down or foundation bolt holes shall be drilled perpendicular to the mounting surface or surfaces and spot faced to a diameter three times that of the hole.

4.2.15 Studded connections shall be furnished with studs installed. Blind stud holes should be drilled only deep enough to allow a preferred tap depth of 1,5 times the major diameter of the stud; the first 1,5 threads at both ends of each stud shall be removed.

4.2.16 External and internal bolting shall be furnished as follows.

- a) Bolting external to the casing shall be in accordance with the pressure design code. Internal bolting shall have the same thread form.
- b) Studs should be used instead of cap screws (external only).
- c) Adequate clearance shall be provided at bolting locations to permit the use of socket or box wrenches (external only).
- d) Socket, slotted-nut or spanner-type bolting shall not be used unless specifically approved by the purchaser (external only).

4.3 Interstage diaphragms and inlet guide vanes

- **4.3.1** Interstage diaphragms and inlet guide vanes shall be suitable for all specified operating conditions, start-up, shutdown, trip-out, settling out and momentary surge. If intermediate main process connections are used, the purchaser shall specify the maximum and minimum pressures at each connection. The vendor shall confirm that the diaphragms furnished are suitable for the maximum differential pressure.

4.3.2 Internal joints shall be designed to minimize leakage and permit easy disassembly.

4.3.3 Renewable labyrinths shall be provided at all internal close clearance points to minimize internal leakage. These shall be easily replaceable.

4.3.4 Diaphragms shall be axially split unless otherwise approved by the purchaser. The diaphragms shall be furnished with threaded holes for eyebolts or with another means to facilitate removal.

4.3.5 If diaphragm cooling is specified, the top and bottom halves of axially split diaphragms shall have independent cooling passages. Each coolant inlet and outlet connection shall be manifolded at both the top and bottom of each casing.

4.4 Casing connections

4.4.1 General

4.4.1.1 All process gas connections to the casing shall be suitable for the maximum allowable working pressure of the casing (see 4.2.4).

4.4.1.2 All of the purchaser's connections shall be accessible for maintenance without the machine being moved.

4.4.1.3 Connections, pipe, valves and fittings of nominal pipe size DN 32 (NPS 1¼), DN 65 (NPS 2½), DN 90 (NPS 3½) or DN 125 (NPS 5) shall not be used.

4.4.1.4 Connections welded to the casing shall meet the material requirements of the casing, including impact values, rather than the requirements of the connected piping.

4.4.1.5 All welding of connections shall be done before hydrostatic testing (see 6.3.2).

4.4.2 Main process connections

- **4.4.2.1** Inlet and outlet connections shall be flanged or machined and studded and oriented as specified in the data sheets (see annex A). Inlet and outlet connections for barrel type compressors shall be located in the outer casing, not in the end covers. On radially split overhung design compressors, the process inlet connection may be in the end cover.

- **4.4.2.2** Flanges shall be in accordance with the pressure design code. If specified, the vendor shall supply all mating flanges, including studs and nuts.

4.4.2.2.1 Flat-faced flanges with full raised-face thickness may be used on casings other than cast iron.

4.4.2.2.2 Unless otherwise specified, flanges that are thicker or have a larger outside diameter than that required by the pressure design code may be used.

4.4.2.3 Cast iron flanges shall be flat-faced and conform to the dimensional requirements of ISO 7005-2. Class 125 flanges shall have a minimum thickness equal to class 250 for sizes DN 200 and smaller.

4.4.2.4 The concentricity of the bolt circle and the bore of all casing flanges shall be such that the area of the machined gasket-seating surface is adequate to accommodate a complete standard gasket without protrusion of the gasket into the fluid flow.

4.4.2.5 The finish of all flanges and nozzles shall conform to the requirements of 4.4.2.2 as applicable to the material furnished, including flange finish roughness requirements.

4.4.3 Auxiliary connections

4.4.3.1 Auxiliary connections may include, but are not limited to, those for vents, liquid injection, drains (see 4.4.3.2) water cooling, "lube and seal" oil, flushing, buffer gas and the balance piston cavity.

- **4.4.3.2** For axially split casings, the vendor shall provide connections for complete drainage of all gas passages. For radially split casings, the drains shall be located at the lowest point of each inlet section, the lowest point of the section between the inner and outer casings and the lowest point of each discharge section. If specified, individual stage drains, including a drain for the balance piston cavity, shall be provided.

4.4.3.3 Flanges shall be in accordance with the pressure design code.

4.4.3.4 Auxiliary connections shall be at least nominal pipe size DN 20 (NPS ¾) (see 4.4.1.3) and shall be socket welded and flanged, or machined and studded. For socket welded construction, a 1,5 mm gap, as measured prior to welding, shall be left between the pipe end and the bottom of the socket in the casing.

4.4.3.5 If socket welded and flanged or machined and studded openings cannot be provided, threaded openings in sizes DN 20 (NPS ¾) to DN 40 (NPS 1½) may be used if approved by the purchaser. These threaded openings shall be installed as follows.

- a) Threaded openings and bosses for pipe threads shall comply with the pressure design code.
- b) Pipe threads shall be taper threads (e.g. ISO 7 or ASME B 1.20.1) and shall comply with the pressure design code.
- c) Threaded connections shall not be used for flammable or toxic fluids. Where threaded joints are permitted, they shall not be seal welded.

4.4.3.6 A pipe nipple, which should not be more than 150 mm (6 in) long, shall be installed in a threaded or socket weld opening. Pipe nipples shall be a minimum of schedule 160 seamless for threaded connections and schedule 80 for socket welded connections. Each pipe nipple shall be provided with a welding neck, socket weld or slip-on flange.

NOTE The schedules are as specified in ASME B 36.10M.

4.4.3.7 Tapped openings not connected to piping shall be plugged with solid steel plugs. As a minimum these plugs shall meet the material requirements of the casing. Plugs that may later require removal shall be of corrosion-resistant material. Threads shall be lubricated. Tape shall not be applied to threads of plugs inserted into oil passages. Plastic plugs shall not be used.

4.5 External forces and moments

4.5.1 The compressor shall be designed to withstand external forces and moments on each nozzle calculated in accordance with Annex G. The vendor shall furnish the allowable forces and moments for each nozzle in tabular form together with the co-ordinates.

4.5.2 Casing and supports shall be designed to have sufficient strength and rigidity to limit coupling misalignment caused by imposing allowable forces and moments to 50 µm (0,002 in).

4.6 Rotating elements

4.6.1 Shafts shall be made of one-piece heat-treated steel, suitably machined. Shafts that have a finished diameter larger than 200 mm (8 in) shall be forged steel. Shafts that have a finished diameter of 200 mm (8 in) or less shall be forged steel or, with the purchaser's approval, hot rolled bar stock, providing that the bar stock meets all quality and heat treatment criteria established for shaft forgings.

4.6.2 Shaft ends for coupling fits shall be in accordance with ISO 10441.

4.6.3 Unless other shaft protection is approved by the purchaser, renewable shaft sleeves shall be furnished at all close clearance points unless rotating seals are used. These sleeves shall be made of a material that is corrosion-resistant in the specified service. The sleeves under close clearance bushing end seals shall be suitably treated to resist wear, and sealed to prevent leakage between the shaft and sleeve (see 4.11.1.7 for limitations).

4.6.4 The design of shaft-sleeve-impeller assemblies shall not create temporary or permanent distortions of the rotor assembly. The method of attaching the impeller shall adequately maintain concentricity and balance under all specified operating conditions, including overspeed to trip speed.

4.6.5 The rotor shaft sensing areas to be observed by radial vibration probes shall be concentric with the bearing journals. All shaft sensing areas (both radial vibration and axial position) shall be free from stencil and scribe marks or any other surface discontinuity, such as an oil hole or a keyway. These areas shall not be metallised, sleeved, or plated. The final surface finish shall be 0,4 µm to 0,8 µm (16 to 32 micro-inches) *Ra*, preferably obtained by honing or burnishing. These areas shall be properly demagnetized or otherwise treated so that the combined total electrical and mechanical runout does not exceed 25 % of the maximum allowed peak-to-peak vibration amplitude or the following value, whichever is greater:

- a) for areas to be observed by radial vibration probes, 6 μm (250 micro-inches);
- b) for areas to be observed by axial position probes, 13 μm (250 micro-inches).

If all reasonable efforts fail to achieve these limits, the vendor and the purchaser shall mutually agree on alternate acceptance criteria.

4.6.6 Each rotor shall be clearly marked with a unique identification number. This number shall be on the end of the shaft opposite the coupling or in an accessible area that is not prone to maintenance damage.

4.6.7 Impellers may be closed, consisting of a disk, vanes, and a cover, or they may be semi-open, consisting of a disk and vanes. Impellers shall be of welded, brazed, milled or cast construction. Other manufacturing methods, such as electroerosion and riveting, may be used if approved by the purchaser. Each impeller shall be marked with a unique identification number.

4.6.8 Welded, brazed and riveted impellers may consist of forged and cast components. Welds in the gas passageway shall be smooth and free from weld spatter. Impellers shall be heat-treated and stress-relieved after welding or brazing. Vane entrance and exits shall not have knife edges.

4.6.9 Cast impellers shall be finished all over except for gas passageways. Upgrade or repair welding may be permitted only with the purchaser's approval.

4.6.10 Welding as a means of balancing an impeller is not permitted.

4.6.11 The design of stressed parts shall include proper evaluation of the stress concentration factor (SCF) for the geometry. The design of stressed rotating parts shall include fillets that limit the SCF.

NOTE Areas of concern include the impeller vane-to-disk intersections, keyways and shaft section changes.

4.6.12 Integral thrust collars are preferred. Replacement thrust collars shall be furnished if required for removal of liquid film type, mechanical contact type or gas type shaft seals. If integral collars are furnished, they shall be provided with at least 3 mm ($\frac{1}{8}$ in) of additional stock to enable refinishing if the collar is damaged. If replaceable collars are furnished (for assembly and maintenance purposes), they shall be positively locked to the shaft to prevent fretting.

4.6.13 Both faces of thrust collars shall have a surface finish of not more than 0,4 μm (16 micro-inches) *Ra* and the axial total indicated runout of either face shall not exceed 13 μm (500 micro-inches).

4.6.14 Compressor designs that do not require a balance drum are acceptable.

4.6.15 If required, a balance drum, line and porting shall be provided to limit axial loads on the thrust bearings. A separate pressure tap connection or connections shall be provided to indicate the pressure in the balancing chamber, not in the balance line.

4.6.16 The balance line shall be flanged and sized to handle balance drum gas leakage at twice the initial design labyrinth clearance without exceeding the load rating of the thrust bearings (see 4.7.3.3). If the balance line requires a purchaser connection to this piping, then the connection sizes shall be indicated on the data sheets (see Annex A).

4.6.17 To prevent the build-up of potential voltages in the shaft, residual magnetism of the rotating element shall not exceed 0,000 5 T (5 gauss).

4.7 Bearings and bearing housings

4.7.1 General

4.7.1.1 Hydrodynamic radial and thrust bearings shall be provided unless specific approval to the contrary is obtained from the purchaser.

NOTE Annex J gives application considerations for use of active magnetic bearings, where specified. These bearings are new technology at this time.

4.7.1.2 Unless otherwise specified, thrust bearings and radial bearings shall be fitted with bearing metal temperature sensors installed in accordance with API 670.

4.7.2 Radial bearings

4.7.2.1 Radial bearings of the sleeve or pad type shall be used and shall be split for ease of assembly. The use of non-split designs requires the purchaser's approval. The bearings shall be precision bored with steel-backed, babbitted replaceable liners, pads or shells. The bearings shall be equipped with anti-rotation pins and shall be positively secured in the axial direction.

4.7.2.2 The bearing design shall suppress hydrodynamic instabilities and provide sufficient damping over the entire range of allowable bearings clearances to limit rotor vibration to the maximum specified amplitudes (see 4.9.5.6) while the equipment is operating loaded or unloaded at any speed (see 4.9.1.3) within the specified speed range.

4.7.2.3 The liners, pads or shells shall be in axially split housings and shall be replaceable. The removal of the top half of the casing of an axially split machine or the head of a radially split unit shall not be required for replacement of these elements. The bearing design shall not require removal of the coupling hub to permit replacement of the bearing liners, pads or shells unless approved by the purchaser.

4.7.2.4 Compressors equipped with sleeve type journal bearings shall be designed for field installation of tilting pad type radial bearings without remachining of the bearing bracket.

4.7.3 Thrust bearings

4.7.3.1 Hydrodynamic thrust bearings shall be of the steel-backed, babbitted multiple segment type, designed for equal thrust capacity in both directions and arranged for continuous pressurized lubrication to each side. Both sides shall be of the tilting pad type incorporating a self-levelling feature assuring that each pad carries an equal share of the thrust load, even with minor variations, in pad thickness.

4.7.3.2 Each pad shall be designed and manufactured with dimensional precision (thickness variation) such that interchangeability or replacement of the individual pads is allowed.

4.7.3.3 Thrust bearings shall be sized for continuous operation under the most adverse specified operating conditions. Calculation of the thrust force shall include, but shall not be limited to, the following factors:

- a) seal maximum design internal clearances and twice the maximum design internal clearances;
- b) pressurized rotor diameter step changes;
- c) stage maximum differential pressures;
- d) specified extreme variations in inlet, interstage, and discharge pressures;
- e) external thrust forces transmitted through the couplings;
- f) the maximum thrust force from the drive motor if the motor is directly connected.

4.7.3.4 For gear type coupling, the external thrust force shall be calculated from the following formula:

$$F = \frac{(0,25) \times (9\ 550) P_r}{N_r \times D}$$

Or, in US customary units:

$$F = \frac{(0,25) \times (63\,300) P_r}{N_r \times D}$$

where

F is the external force, kilonewtons (pound force);

P_r is the rated power, in kilowatts (horsepower);

N_r is the rated speed, in revolutions per minute;

D is the shaft diameter of the coupling, in millimetres (inches).

4.7.3.5 Thrust forces for flexible element type couplings shall be calculated on the basis of the maximum allowable deflection permitted by the coupling manufacturer.

4.7.3.6 If two or more rotor thrust forces are to be carried by one thrust bearing (such as in a gear box) the resultant of the forces shall be used, provided the directions of the forces make them numerically additive; otherwise, the largest of the forces shall be used.

4.7.3.7 Hydrodynamic thrust bearings shall be selected such that, under any operating condition, the load does not exceed 50 % of the bearing manufacturer's ultimate load rating. The ultimate load rating shall be the load that will produce the minimum acceptable oil film thickness without inducing failure during continuous service, or the greatest load that does not exceed the creep initiation or yield strength of the babbitt at the location of maximum temperature on the pad, whichever load is the lesser of the two. In sizing thrust bearings, consideration shall be given to the following for each specific application:

- a) shaft speed;
- b) temperature of the bearing babbitt;
- c) deflection of the bearing pad;
- d) minimum oil film thickness;
- e) feed rate, viscosity, and supply temperature of the oil;
- f) design configuration of the bearing;
- g) babbitt alloy and pad material;
- h) turbulence of the oil film.

The basis for the sizing of thrust bearings shall be reviewed and approved by the purchaser.

4.7.3.8 Thrust bearings shall be arranged to allow axial positioning of each rotor relative to the casing and setting of the thrust bearings' clearance.

4.7.4 Bearing housings

4.7.4.1 Rotor support system parts (bearings, bearing housings, bearing shells, and bearing brackets) shall be axially split, non-pressurized (vented to atmosphere) and furnished with plugged connections for dry air or inert gas purge to any atmospheric labyrinth seals. Axial split bearing housings shall have a metal-to-metal split joint whose halves are located by means of dowels.

4.7.4.2 Compressors that use semi-enclosed coupling guards shall have bearing housings equipped with replaceable labyrinth type end seals and deflectors where the shaft passes through the housing; lip type seals shall not be used. The seals and deflectors shall be made of non-sparking materials. The design of the seals and deflectors shall effectively retain oil in the housing and prevent entry of foreign material into the housing.

4.7.4.3 Bearing housings for pressure-lubricated hydrodynamic bearings shall be arranged to minimize foaming. The drain system shall be adequate to maintain the oil and foam level below shaft end seals. Oil outlets from flooded thrust bearings shall be tangential and in the upper half of the control ring or, if control rings are not used, in the thrust bearing cartridge.

4.7.4.4 The rise in oil temperature through the bearing and housing shall not exceed 30 °C (50 °F) under the most adverse specified operating conditions. The bearing outlet oil temperature shall not exceed 85 °C (180 °F). If the inlet oil temperature exceeds 50 °C (120 °F), special consideration shall be given to bearing design, oil flow and allowable temperature rise.

4.7.4.5 Shaft support structures bolted to casings shall be of steel.

4.7.4.6 Oil connections on bearing housings shall be in accordance with 4.4.3.

4.7.4.7 Provision shall be made for mounting two radial vibration probes in each bearing housing, two axial position probes at the thrust end of each machine, and a one event per revolution probe in each machine shaft line. The probe installation shall be as specified in API 670.

4.8 Shaft seals

4.8.1 General

- **4.8.1.1** Shaft seals shall be provided to restrict or prevent process gas leakage to the atmosphere or seal fluid leakage into the process gas stream over the range of specified operating conditions, including start-up and shutdown. Seal operation shall be suitable for specified variations in suction conditions that may prevail during start-up, shutdown or settling out, or during any other special operation specified by the purchaser, such as slow roll or reverse rotation. The maximum sealing pressure shall be at least equal to the settling out pressure. The shaft seals and seal system shall be designed to permit safe compressor pressurization with the seal system in operation prior to process start-up.

The purchaser should establish a realistic value for the settling out pressure. The value should be shown on the data sheets.

- **4.8.1.2** Shaft seals and, if specified, shaft sleeves shall be accessible for inspection and replacement without removing the top half of the casing of an axially split compressor or the heads of a radially split unit.

NOTE It is recognized that this requirement may not be feasible for overhung designs or shrink fit sleeves.

- **4.8.1.3** Shaft seals may be one or a combination of the following (4.8.2.1 to 4.8.2.5) types as specified by the purchaser on the data sheets. The materials for component parts shall be suitable for the service.

4.8.2 Requirements for types

4.8.2.1 The labyrinth seal (a typical seal is shown in Figure 2) may include carbon rings in addition to the labyrinths, if approved by the purchaser. Labyrinths may be stationary or rotating. Eductors or injection systems, if used, shall be furnished complete with piping regulation and control valves, pressure gauges, strainers, and so forth. Each item shall be piped and valved to permit its removal during operation of the compressor. Where gas from the compressor discharge is used for the motivating power of the eductor, provisions shall be made for sealing during start-up and shutdown (see 4.8.3.4 and 5.5.1.6).

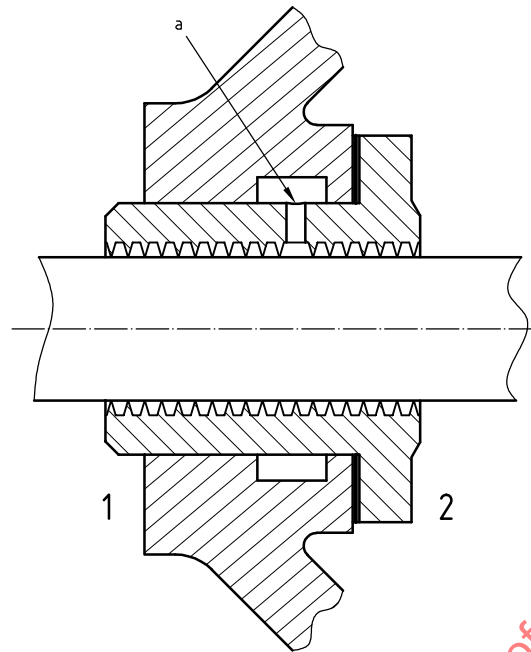

Key

- 1 Internal gas pressure
- 2 Atmosphere
- a Ports may be added for scavenging, inert-gas sealing or both.

Figure 2 — Labyrinth shaft seal

- **4.8.2.2** The mechanical (contact) seal (see Figure 3) shall be provided with labyrinths and slingers. Oil or another suitable liquid furnished under pressure to the rotating seal faces may be supplied from the lube oil system or from an independent seal system. Mechanical seals shall be designed to prevent gas leakage while the compressor is pressurized and being shut down, and after it is stopped in the event of seal oil failure. Various supplemental devices may be provided to ensure sealing when the compressor is pressurized but not running and the seal oil system is shut down. The purchaser shall specify whether such a device is to be provided. The final design shall be mutually agreed upon by the purchaser and the vendor.

4.8.2.3 The restrictive ring seal (see Figure 4) shall include rings of carbon or another suitable material mounted in retainers or in spacers. The seal may be operated dry, as in the labyrinth type, or with a sealing liquid, as in the mechanical type or with a buffer gas.

4.8.2.4 The liquid film seal (see Figures 5 and 6) shall be provided with sealing rings or bushings and labyrinths. A sealing liquid shall be supplied as in the mechanical type. Liquid film seals may be of the cylindrical bushing type shown in Figure 5 or the pumping type shown in Figure 6. An elevated tank to maintain static head in excess of the compressor sealing pressure shall be provided. The vendor shall state the height of the tank above the compressor centreline. Other means of maintaining this differential pressure and positive seal may be used with the purchaser's approval.

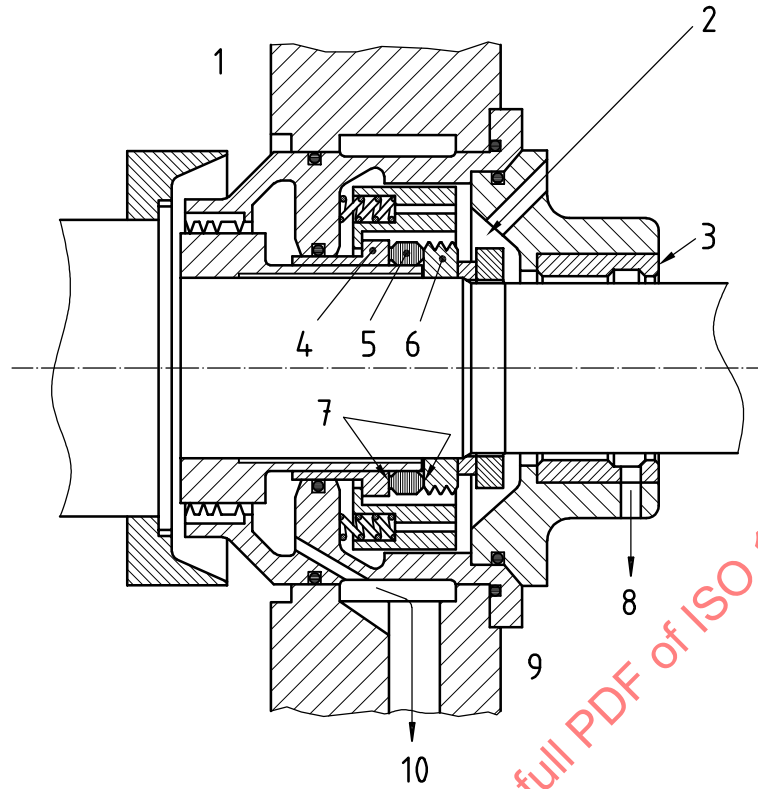

Key

- | | |
|-----------------------------|-------------------------|
| 1 Internal gas pressure | 6 Rotating seat |
| 2 Clean oil in | 7 Running faces |
| 3 Pressure breakdown sleeve | 8 Oil out |
| 4 Stationary seat | 9 Atmosphere |
| 5 Sealing ring | 10 Contaminated oil out |

Figure 3 — Mechanical (contact) shaft seal

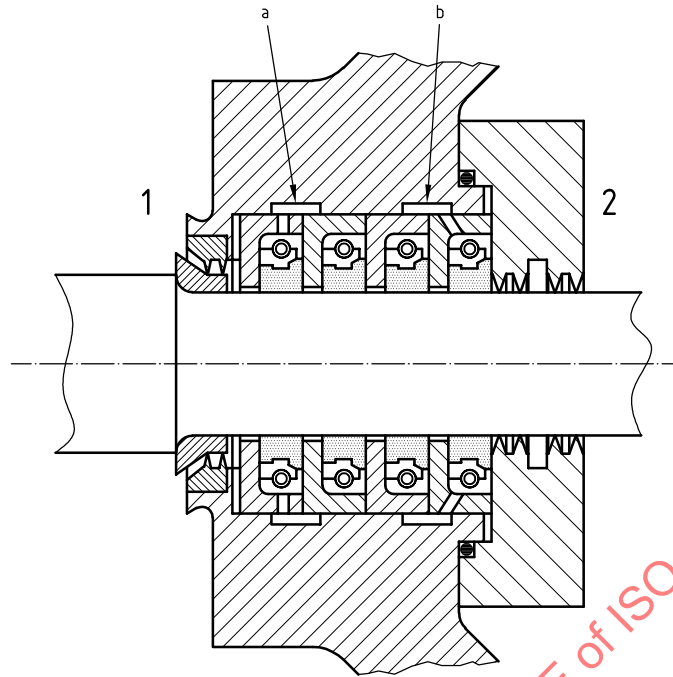
**Key**

- 1 Internal gas pressure
- 2 Atmosphere

- a Ports may be added for sealing.
- b Scavenging port may be added for vacuum application.

Figure 4 — Restrictive ring shaft seal

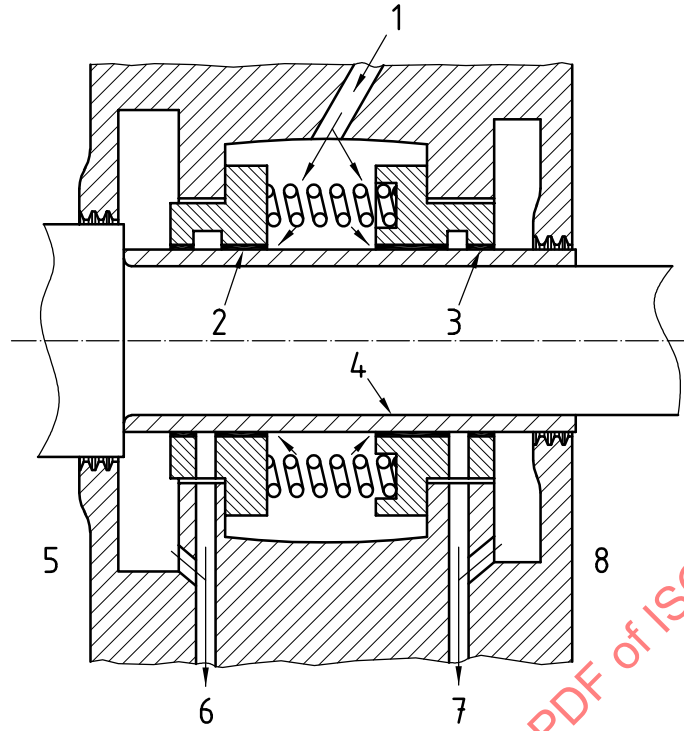

Key

- | | |
|-----------------|-------------------------|
| 1 Clean oil in | 5 Internal gas pressure |
| 2 Inner bushing | 6 Contaminated oil out |
| 3 Outer bushing | 7 Oil out |
| 4 Shaft sleeve | 8 Atmosphere |

Figure 5 — Liquid film shaft seal with cylindrical bushings

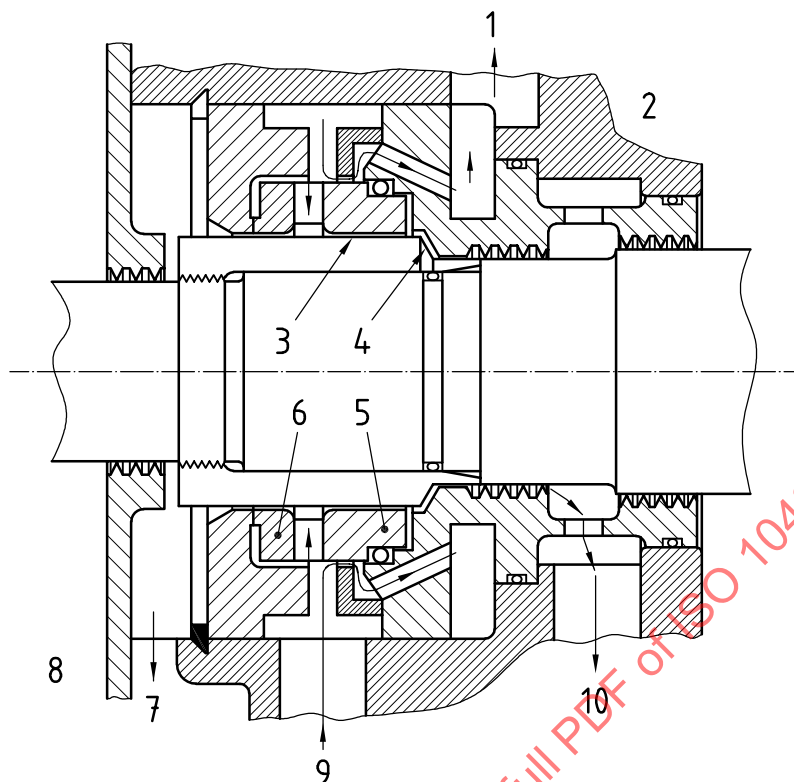
**Key**

- | | |
|---------------------------|-------------------------|
| 1 Clean oil recirculation | 6 Outer bushing |
| 2 Internal gas pressure | 7 Oil out |
| 3 Shaft sleeve | 8 Atmosphere |
| 4 Pumping area | 9 Clean oil in |
| 5 Inner bushing | 10 Contaminated oil out |

Figure 6 — Liquid film seal with pumping bushings

4.8.2.5 The self-acting gas seal may require a clean seal gas supply but does not require any liquid lubrication. The purchaser may specify the required seal configuration. Typical tandem seal configurations are shown in Figures 7 and 8. In these configurations, two identical seals are arranged in series as primary and back-up seals, one configuration without an internal labyrinth (Figure 7), and the other configuration with an internal labyrinth (Figure 8). Where there is danger of leakage of toxic or flammable gases to the atmosphere, then the arrangement in Figure 8 shall be used. A separation seal is generally required to prevent leakage to the atmosphere or to the bearing housing as well as oil leakage to the seal.

The seal gas shall be filtered and free from any contaminants that form residues. The seal gas may be taken from the compressor discharge or interstage point. An alternative seal gas source may be used and may be required during start-up and shutdown. Suitable measures shall be taken to protect the seal against reverse pressurization. The method of control shall be mutually agreed between purchaser and vendor. For testing considerations at the seal manufacturer's shop for this type of seal, see annex I and the data sheets (annex A).

Other configurations, for example, single, double (back-to-back) or triple, may be used, depending on the application.

NOTE 1 For certain applications external cooling of seals could be required.

NOTE 2 The seal will leak a small amount of seal gas.

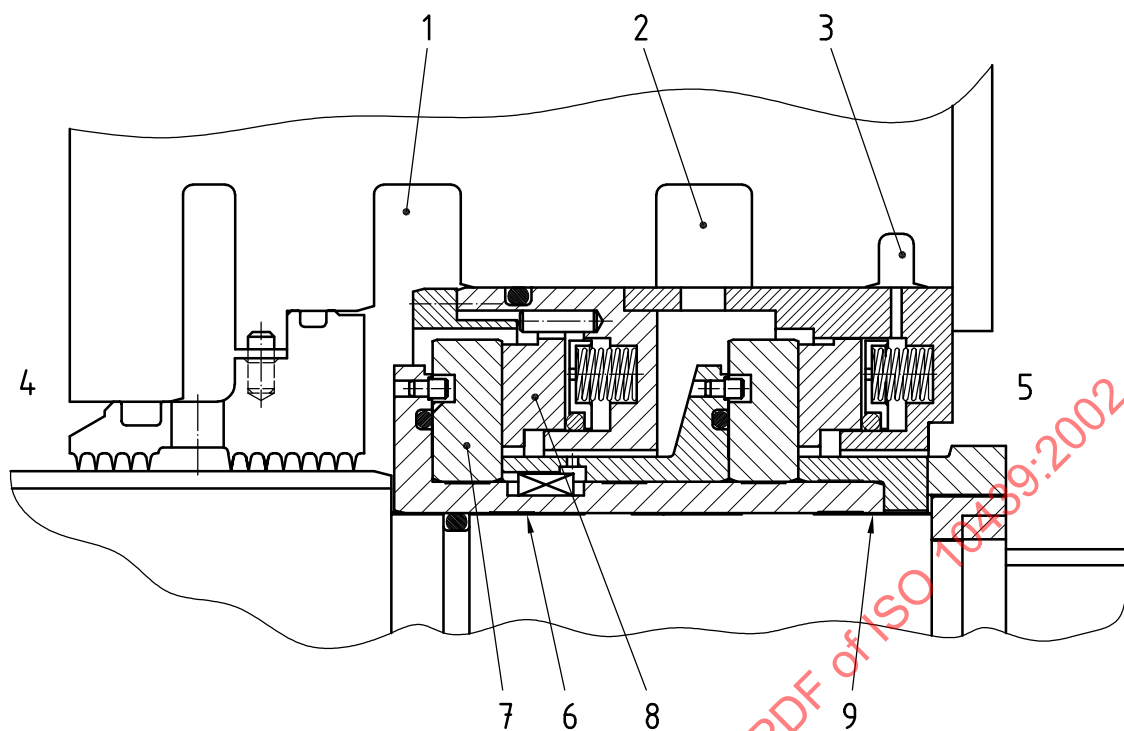

Key

- | | |
|----------------------------------|-------------------|
| 1 Seal gas in | 6 Primary seal |
| 2 Primary seal leakage | 7 Rotating seat |
| 3 Buffer gas supply | 8 Stationary seat |
| 4 Internal gas pressure | 9 Backup seal |
| 5 Atmospheric or bearing housing | |

Figure 7 — Self-acting tandem gas seal

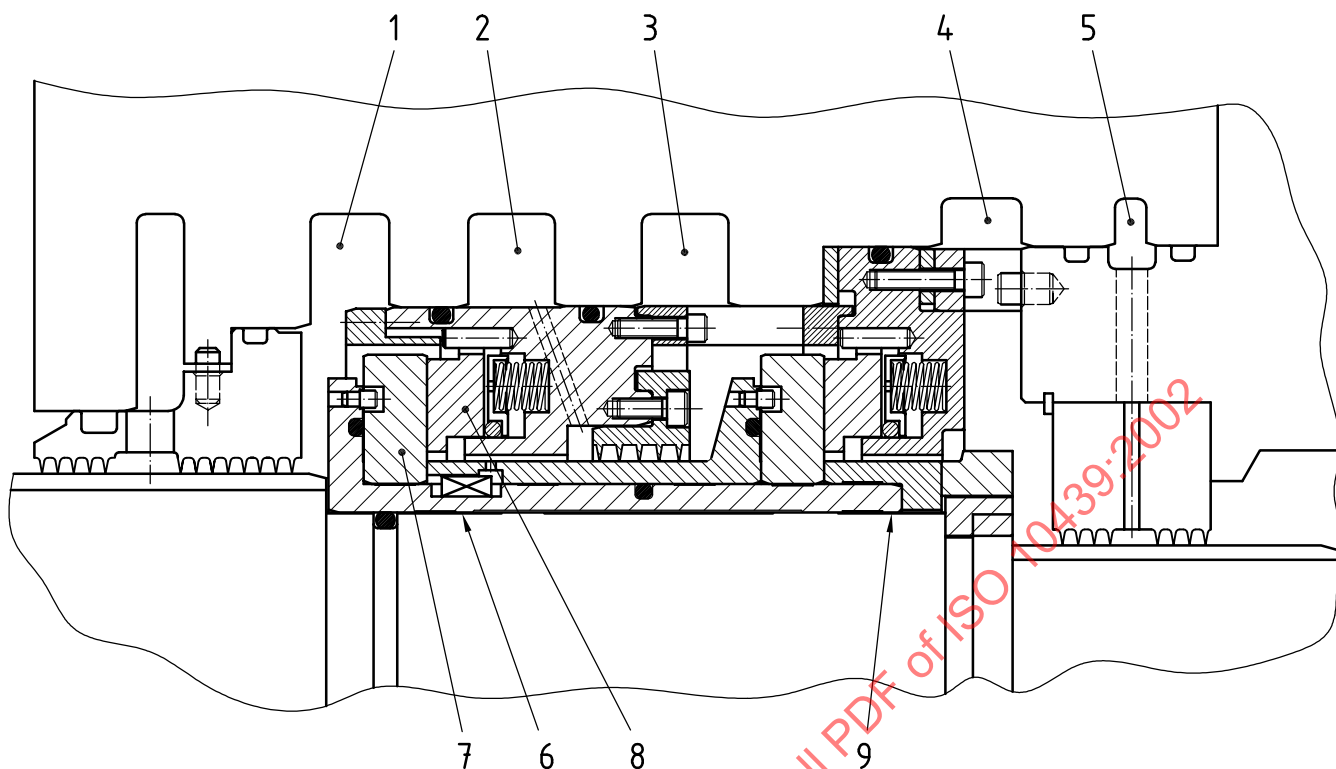

Key

1 Seal gas in	6 Primary seal
2 Primary seal leakage	7 Rotating seat
3 Buffer gas	8 Stationary seat
4 Atmospheric vent	9 Backup seal
5 Separation gas	

Figure 8 — Self-acting tandem gas seal with internal labyrinth

4.8.3 Other requirements

4.8.3.1 For any shaft end seals that use sealing liquid, the inward leakage from each seal shall be piped to an independent drain pot. The individual shaft end inward seal leakages shall be adequate to prevent outward migration of process gas. No individual shaft end seal shall have a leakage rate greater than 70 % of the total expected leakage from all shaft end seals in a single machine.

4.8.3.2 Oil contaminated by process gas that would damage components such as bearings, seal rings, O-rings and couplings shall be piped away separately to allow disposal or reconditioning.

4.8.3.3 Seal pressure equalizing lines and associated gas passages (including those for reference gas and axial thrust force balancing) shall be sized to maintain design shaft end seal performance at twice the maximum initial design clearances. The lines and passages shall also be sized to maintain substantially equal pressures at both shaft end seals during acceleration.

- **4.8.3.4** Unless otherwise specified, the seal design shall have provision for buffer gas injection to each seal. The purchaser shall specify whether buffer gas injection is to be used and, if so, the composition of that gas. In addition, the vendor shall state whether buffer gas injection is required for any specified operating conditions. If buffer gas injection is required (see Figure 8), the vendor shall state the gas requirements, and, if specified, furnish the complete control system schematic and bill of material. The method of control shall be mutually agreed between vendor and purchaser.
- **4.8.3.5** If specified for compressors with sub-atmospheric pressure at the shaft end seals, provision shall be made to pressurize these seals with gas at a pressure that is higher than atmospheric.

4.9 Dynamics

4.9.1 Critical speeds

4.9.1.1 If the frequency of a periodic forcing phenomenon (exciting frequency) applied to a rotor-bearing support system corresponds to a natural frequency of that system, the system may be in a state of resonance.

4.9.1.2 A rotor-bearing support system in resonance shall have its normal vibration displacement amplified. The magnitude of amplification and the rate of phase angle change are related to the amount of damping in the system and the mode shape taken by the rotor.

NOTE The mode shapes are commonly referred to as the first rigid (translatory or bouncing) mode, the second rigid (conical or rocking) mode and the (first, second, third ...*n*th) bending mode.

4.9.1.3 When the rotor amplification factor (see Figure 9) as measured on the test stand at the vibration probe is greater than or equal to 2,5, that frequency is called critical and the corresponding shaft rotational frequency is called a "critical speed". For the purposes of this International Standard, a critically damped system is one in which the amplification factor is less than 2,5.

4.9.1.4 Critical speeds shall be determined analytically by means of a damped, unbalanced rotor response analysis and shall be confirmed by test stand data.

4.9.1.5 An exciting frequency may be less than, equal to, or greater than the rotational speed of the rotor. Potential forced and self-exciting frequencies considered in system design shall include, but are not limited to, the following sources:

- a) unbalance in the rotor system;
- b) oil film instabilities (whirl);
- c) internal rubs;
- d) blade, vane, nozzle, and diffuser passing frequencies;
- e) gear tooth meshing and side bands;
- f) coupling misalignment;
- g) loose rotor system components;
- h) hysteretic and friction whirl;
- i) boundary layer flow separation;
- j) acoustic and aerodynamic cross coupling forces;
- k) asynchronous whirl.

4.9.1.6 Resonances of support systems within the vendor's scope of supply shall not occur within the specified operating speed range or the specified separation margins, unless the resonances are critically damped.

4.9.1.7 The vendor having unit responsibility shall ensure the compatibility of drive-train critical speeds (rotor lateral, system torsional, blading modes, and the like) with the critical speeds of the machinery being supplied and that the combination is suitable for the specified operating speed range, including any starting speed detent (hold point) requirements of the train. A list of all undesirable speeds from zero to trip shall be submitted to the purchaser for review and included in the instruction manual for the guidance of the purchaser (see annex C).

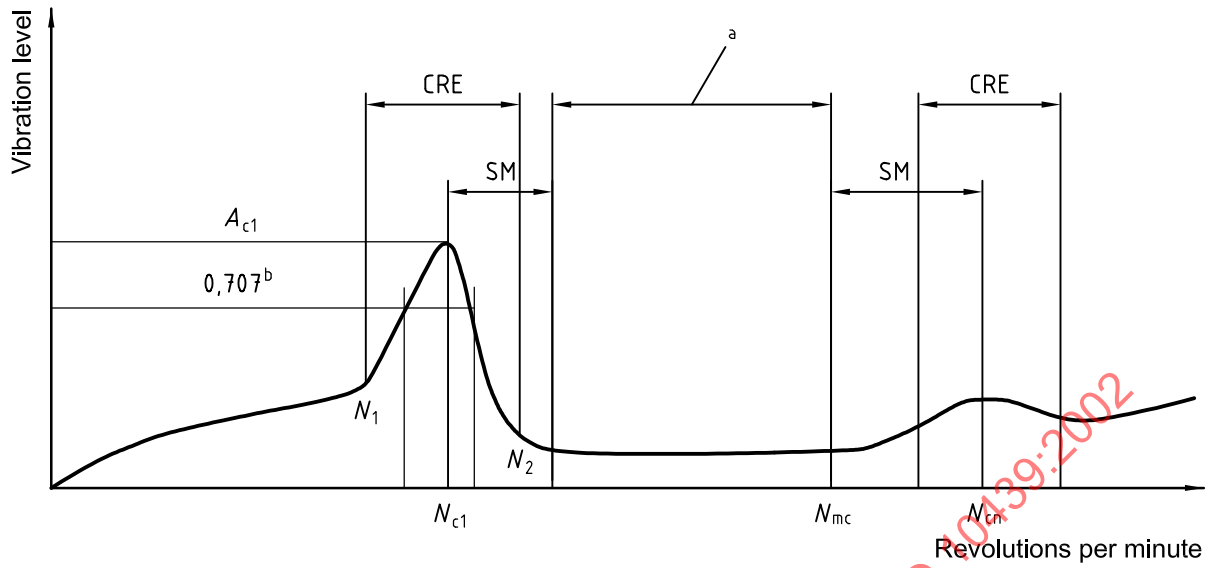

Key

- N_{c1} rotor first critical, centre frequency, cycles per minute
- N_{cn} critical speed, n th
- N_{mc} maximum continuous speed, 105 %
- N_1 initial (lesser) speed at 0,707 times peak amplitude (critical)
- N_2 final (greater) speed at 0,707 times peak amplitude (critical)
- $N_2 - N_1$ peak width at the half-power point

μ amplification factor $\mu = \frac{N_{c1}}{N_2 - N_1}$

- SM** separation margin
- CRE** critical response envelope
- A_{c1} amplitude at N_{c1}
- A_{cn} amplitude at N_{cn}

NOTE The curve shape is for illustration only and does not necessarily represent any actual rotor response plot.

- a Operating speeds.
- b Peak.

Figure 9 — Rotor response plot

4.9.2 Lateral analysis

4.9.2.1 The vendor shall provide a damped, unbalanced response analysis for each machine in order to ensure acceptable amplitudes of vibration at any speed from zero to trip. An example of the logic diagram of the lateral analysis and test procedures is provided in annex E.

4.9.2.2 The damped, unbalanced response analysis shall include, but shall not be limited to, the following considerations.

- a) Support (base, frame, and bearing housing) stiffness, mass and damping characteristics, including effects of rotational speed variation. The vendor shall state the assumed support system values.
 - b) Bearing lubricant film stiffness and damping changes due to speed, load, preload, oil temperatures, accumulated assembly tolerances and maximum-to-minimum clearances.
 - c) Rotational speed, including the various starting speed detents, operating speed and load ranges (including agreed upon test conditions if different from those specified), trip speed, and coast-down conditions.
 - d) Rotor masses, including the mass moment of coupling halves, stiffness and damping effects (for example, accumulated fit tolerances, and frame and casing effects).
 - e) The influence over the operative range of the calculated values for hydrodynamic stiffness and damping generated by the casing, seals and labyrinths.
- **4.9.2.3** If specified, the effects of other equipment in the train shall be included in the damped, unbalanced response analysis (i.e. a train lateral analysis shall be performed).

EXAMPLE A train lateral analysis should be specified for trains with a rigid coupling.

4.9.2.4 The damped unbalanced response analysis shall include items a) to e) as follows. (See annex C).

- a) A plot and identification of the mode shape at each resonant speed (critically damped or not) from zero to trip, as well as the next mode occurring above the trip speed.
- b) Frequency, phase and response amplitude data at the vibration probe locations through the range of each critical speed, using the following arrangement of unbalance for the particular mode. This unbalance shall be sufficient to raise the displacement of the rotor at the probe locations to the vibration limit defined by the following equation:

$$L_v = 25,4 \sqrt{12\,000 / N}$$

or in US customary units,

$$L_v = \sqrt{12\,000 / N}$$

where

L_v is the vibration limit (amplitude of unfiltered vibration), in micrometres (mil), peak-to-peak;

N is the operating speed nearest the critical of concern, in revolutions per minute.

The unbalance shall be no less than two times the unbalance limit specified in 4.9.5.3. The unbalance mass or masses shall be placed at the location or locations within the bearing span that have been analytically determined as affecting the particular mode most adversely (e.g. at mid-span for translatory modes or near both ends and 180° out of phase for conical modes). For bending modes with maximum deflections at the shaft's ends, the amount of unbalance shall be based on the overhung mass rather than the static bearing loading.

- c) Modal diagrams for each response in b), indicating the phase and major axis amplitude at each coupling engagement plane, the centrelines of the bearings, the locations of the vibration probes, at each seal area throughout the machine. The minimum design diametrical running clearance of the seals shall also be indicated.
- d) For the purposes of the verification test (see 4.9.3), an additional plot of a test unbalance, as specified in b) (based on static bearing loading for rigid modes or based on overhung mass for bending modes). This test mass shall be at least two times and no more than eight times the unbalance limit specified in 4.9.5.3, and shall be placed at a location determined by the vendor.
- e) If specified, the generation of a stiffness map of the undamped rotor response from which the damped unbalance response analysis specified in c) has been derived. This plot shall show frequency versus support system stiffness with the calculated support system stiffness curves superimposed.

4.9.2.5 The damped unbalance response analysis shall indicate that the machine in the unbalanced condition 4.9.2.4, b), shall meet the following acceptance criteria (see Figure 9).

- a) If the amplification factor is less than 2,5, the response is considered critically damped and no separation margin is required.
- b) If the amplification factor is 2,5 to 3,55, a separation margin of 15 % above the maximum continuous speed and 5 % below the minimum operating speed is required.
- c) If the amplification factor, μ , is greater than 3,55 and the critical response peak is below the minimum operating speed, the required separation margin (a percentage of minimum speed) is calculated as follows:

$$SM = 100 - \left(84 + \frac{6}{\mu - 3} \right)$$

- d) If μ is greater than 3,55 and the critical response peak is above the trip speed, the required SM (a percentage of maximum continuous speed) is equal to the following:

$$SM = \left(126 - \frac{6}{\mu - 3} \right) - 100$$

4.9.2.6 The calculated unbalanced peak-to-peak rotor amplitudes [see 4.9.2.4.b)] at any speed from zero to trip shall not exceed 75 % of the minimum design diametrical running clearances throughout the machine (with the exception of floating ring and abradable seal locations).

4.9.2.7 If, after the purchaser and the vendor have agreed that all practical design efforts have been exhausted, the analysis indicates that the separation margins still cannot be met or that a critical response peak falls within the operating speed range, acceptable amplitudes shall be mutually agreed upon by the purchaser and the vendor, subject to the requirement of 4.9.2.6.

- **4.9.2.8** If specified, or when average gas density in a compressor casing exceeds 60 kg/m³ (3,75 lb/ft³), the vendor shall carry out a rotor stability analysis. This shall be made at rated speed for constant speed machines and over the speed range from minimum to maximum continuous speed for variable speed compressors. The analysis shall be performed without, and then with, destabilizing aerodynamic effects, taking into account the highest gas density. The results are to be provided as plots showing the damped critical speeds and the log decrement as a function of speed. The vendor should demonstrate the acceptability of the calculated value of log decrement by reference to similar machines in satisfactory operation. This should be over the speed range from minimum to maximum continuous speed. This stability analysis should also take into account all items listed in 4.9.2.2.

4.9.3 Shop verification of unbalanced response analysis

- **4.9.3.1** If specified, the vendor shall demonstrate the accuracy of the vendor's unbalanced response calculation by performing an unbalanced response test in accordance with 4.9.

4.9.3.2 The actual critical speed responses, as revealed on the test stand with a rotor unbalance magnitude in accordance with 4.9.2.4, d), placed at a location (usually the coupling) determined by the vendor, shall be the criteria for confirming the validity of the damped unbalanced response analysis.

NOTE It is recognized that the dynamic response of the machine on the test stand will be a function of the agreed upon test conditions and that unless the test stand results are obtained at the conditions of pressure, temperature, speed, and load expected in the field, they may not be the same as the results expected in the field.

4.9.3.3 The parameters to be measured during the test shall be speed and shaft vibration amplitudes with corresponding phase. The vibration amplitudes and phase from each pair of $x-y$ vibration probes shall be vectorially summed at each response peak to determine the maximum amplitude of vibration. The major axis amplitude of each response peak shall not exceed the limits specified in 4.9.2.6. The gain of the recording instrumentation used shall be predetermined and preset before the test so that the highest response peak is within 60 % to 100 % of the recorder's full scale on the test unit coast-down (deceleration).

NOTE 1 It is recognized that vectorial subtraction of slow roll (300 r/min to 600 r/min) total electrical and mechanical runout is always required for this verification and that vectorial subtraction of bearing housing motion is normally required.

NOTE 2 The phase on each vibration signal, x or y , is the angular measure, in degrees, of the phase difference (lag) between a phase reference signal (from a phase transducer sensing a once per revolution mark on the rotor, as described in API 670) and the next positive peak, in time, of the synchronous ($1x$) vibration signal. (If proximity probes are used, this is the lag angle between the vibration probe and the high spot on the rotor).

NOTE 3 The major axis amplitude is properly determined from a lissajous (orbit) display on an oscilloscope, oscillograph or equivalent. If the phase angle between the x and y signals is not 90° , the major axis amplitude can be approximated by $(x^2+y^2)^{1/2}$. If the phase angle between the x and y signals is 90° , the major axis value is the greater of the two vibration signals.

4.9.3.4 Additional testing and correction of the original damped, unbalanced rotor response analysis shall be required if, from the test data described above, or from a phase or amplitude indication in the damped unbalanced response analysis [based on the unbalance conditions described in 4.9.2.4, b)], or both, it appears that either of the following conditions exists:

- a) any critical response fails to meet the separation margin requirements (see 4.9.2.5) or falls within the operating speed range;
- b) the requirement of 4.9.2.6 has not been met.

Unbalance masses shall be determined and placed as mutually agreed upon by the purchaser and the vendor (see 4.9.2.4, b) and d). Unbalance magnitudes shall be achieved by adjusting the residual unbalance that exists in the rotor from the initial run to raise the displacement of the rotor at the probe locations to the vibration limit defined by the equation in 4.9.2.4, b) at the maximum continuous speed. The measurements from this test, taken in accordance with 4.9.3.2, shall indicate the following acceptance criteria for the machine.

- a) at no speed shall the shaft deflections exceed 90 % of the minimum design running clearances.
- b) at no speed within the operating speed range shall the shaft deflections exceed 55 % of the minimum design running clearances or 150 % of the allowable vibration limit at the probes [see 4.9.2.4, b)].

The internal deflection limits specified in a) and b) immediately above shall be based on the calculated displacement ratios between the probe locations and the areas of concern identified in 4.9.2.4, c). Actual internal displacements for these tests shall be calculated by multiplying these ratios by the major axis amplitudes (see 4.9.3.2). Acceptance shall be based on these calculated displacements, not on inspection of seals after testing; however, damage to any portion of the machine as a result of this testing shall constitute failure of the test. Minor internal seal rubs that do not cause clearance changes outside the vendor's new part tolerance do not constitute damage.

4.9.4 Torsional analysis

4.9.4.1 Excitations of torsional natural frequency may come from many sources, which should be considered in the analysis. These sources may include, but are not limited to, the following:

- a) gear problems such as unbalance and pitch line runout;
- b) start-up conditions such as speed detents (under inertial impedances) and other torsional oscillations;
- c) torsional transients such as switch on and terminal short circuit of all kinds of electric motors, start-up, operation and worst-case transient of variable speed electric motors, and start-up of synchronous electric motors.

4.9.4.2 The torsional natural frequency of the complete train shall be at least 10 % above or 10 % below any possible excitation frequency within the specified operating speed range (from minimum to maximum continuous speed).

4.9.4.3 Torsional criticals at two times running speed as well as one and two times the supply frequency for motor driven systems shall preferably be avoided or, in systems in which corresponding excitation frequencies occur, shall be shown to have no adverse effect. In addition to multiples of running speeds, torsional excitations that are not a function of operating speeds or that are non-synchronous in nature shall be considered in the torsional analysis if applicable. Identification of these frequencies shall be the mutual responsibility of the purchaser and the vendor.

4.9.4.4 For the torsional analysis of variable-speed motor-driven compressors, the vendor, together with the variable speed motor supplier shall identify all excitation frequencies and their consequences on the train. These frequencies shall include but not be limited to

- non-speed dependant excitations such as ripple,
- integer harmonics,
- non-integer harmonics,
- carrier frequency harmonics, and
- switching harmonics between speed-control windows.

4.9.4.5 If torsional resonances are calculated to fall within the margin specified above, and the purchaser and vendor have agreed that all efforts to remove the critical from within the limiting frequency range have been exhausted, the vendor shall demonstrate that the resonances have no adverse effect on the complete train.

- **4.9.4.6** For motor-driven units and units including gears, or — if specified — for turbine driven units, the vendor shall perform a torsional vibration analysis of the complete train and shall be responsible for directing the modifications necessary to meet the requirements of 4.9.4.1 to 4.9.4.4.

4.9.4.7 In addition to the torsional analyses required in 4.9.4.2 to 4.9.4.5, the vendor shall perform a transient torsional vibration analysis for motor-driven units. The acceptance criteria for this analysis shall be mutually agreed upon by the purchaser and the vendor.

4.9.5 Vibration and balancing

4.9.5.1 Major parts of the rotating element, such as the shaft, balancing drum and impellers, shall be individually dynamically balanced before assembly to ISO 1940-1 grade G2,5 (with respect to the maximum continuous speed) or better. If a bare shaft with a single key way is dynamically balanced, the key way shall be filled with a fully crowned half-key in accordance with ISO 8821. A shaft with key ways 180° apart, but not in the same transverse plane, shall also be filled thus. The initial balance correction to the bare shaft shall be recorded.

4.9.5.2 The complete rotor shall be balanced either at low speed in accordance with 4.9.5.3 or at high speed in accordance with 4.9.5.5.

4.9.5.3 For low-speed balancing, the rotating element shall be multiplane dynamically balanced during assembly. This shall be accomplished after the addition of no more than two major components. Balancing correction shall be applied only to the elements added. Minor correction of other components may be required

during the final trim balancing of the rotor (see 4.9.5.1). In the sequential balancing process, any half-keys used in the balancing of the bare shaft shall continue to be used until they are replaced with the final key and mating element. The mass of all half-keys used during final balancing of the assembled element shall be recorded on the residual unbalance work sheet (see annex D). The maximum allowable residual unbalance per plane (journal) shall be calculated as follows:

$$U_{\max} = 6\,350\ W / N$$

or, in US customary units,

$$U_{\max} = 4\ W / N$$

where

U_{\max} is the residual unbalance, in gram millimetres (ounce inches);

W is the journal static mass load, in kilograms (pounds);

N is the maximum continuous speed, in revolutions per minute.

If spare rotors are supplied they shall be dynamically balanced to the same tolerances as the main rotor.

4.9.5.4 After the final low-speed balancing of each assembled rotating element has been completed, a residual unbalanced check shall be performed and recorded as described in annex D.

4.9.5.5 High-speed balancing may be done (balancing in a high-speed balancing machine at the operating speed). The acceptance criteria for this balancing shall be mutually agreed upon by the purchaser and the vendor.

4.9.5.6 During the shop test of the machine, assembled with the balanced rotor, operating at its maximum continuous speed or at any other speed within the specified operating speed range, the peak-to-peak amplitude of unfiltered vibration in any plane, measured on the shaft adjacent and relative to each radial bearing, shall not exceed the following value or 50 μm (2,0 mil), whichever is less:

$$A = 25,4\sqrt{12\,000 / N}$$

or, in US customary units,

$$A = \sqrt{12\,000 / N}$$

where

A is the amplitude of unfiltered vibration, in micrometres (mil), peak-to-peak;

N is the maximum continuous speed, in revolutions per minute

At any speed greater than the maximum continuous speed, up to and including the trip speed of the driver, the vibration shall not exceed 150 % of the maximum value recorded at the maximum continuous speed, unless the unbalance response analysis indicates a steeper rise of vibration levels, when the limit shall be that given by calculation or 150 % of those given by the equation above, whichever is the lower.

NOTE These limits are not to be confused with the limits specified in 4.9.3. for shop verification of unbalanced response.

4.9.5.7 Electrical and mechanical runout shall be determined and recorded.

4.9.5.8 If the vendor can demonstrate that electrical or mechanical runout is present, a maximum of 25 % of the test level calculated from the equation in 4.9.5.6 or 6,5 μm (0,25 mil), whichever is greater, may be vectorially subtracted from the vibration signal measured during the factory test.

4.10 “Lube” oil and seal oil systems

4.10.1 Unless otherwise specified, a pressurized oil system or systems shall be furnished to supply oil at a suitable pressure or pressures, as applicable, to the following:

- a) the bearings of the driver and of the driven equipment (including any gear);
- b) the continuously lubricated couplings;
- c) the governing and control oil system;
- d) the seal oil system;
- e) the purchaser's control system (if hydraulic).

4.10.2 Oil reservoirs and housings that enclose moving lubricated parts (such as bearings, shaft seals), highly polished parts, instruments and control elements shall be designed to minimize contamination by moisture, dust and other foreign matter during periods of operation or idleness.

- **4.10.3** The purchaser shall specify whether the seal oil and “lube” oil systems are to be separate or combined. If separate systems are specified, the means of preventing the interchange of oil between the two systems shall be described in the vendor's proposal.

4.10.4 Unless otherwise specified, bearings and bearing housings shall be arranged for hydrocarbon oil lubrication.

4.10.5 Unless otherwise specified, pressurized oil systems shall conform to the requirements of ISO 10438. If approved by the purchaser, a pressurized integral oil system may be provided for a closed loop, non-hydrocarbon refrigerant refrigeration system.

4.11 Materials

4.11.1 General

4.11.1.1 Construction materials shall be at the manufacturer's discretion for the specified operating conditions, except as required or prohibited by the data sheets or otherwise by this International Standard. Table B.1 in annex B lists material specifications that, if used with appropriate heat treatment or impact testing requirements or both, are generally considered acceptable for major component parts. Other international material specifications may, by agreement between purchaser and vendor, be used for major component parts. The metallurgy of all major components shall be clearly stated in the vendor's proposal. See 5.5 for requirements for auxiliary piping materials.

4.11.1.2 Materials and the material grade shall be identified in the proposal using established international, national or industry designations. If no such designation is available, the vendor's material specification, giving physical properties, chemical composition and test requirements, shall be included in the proposal.

- **4.11.1.3** Copper and copper alloys (excluding Monel or its equivalent, bearing babbitt, and precipitation hardening stainless steels) shall not be used for parts of compressors or auxiliaries in contact with corrosive gas or with gases capable of forming explosive copper compounds. The purchaser shall note such gas characteristics on the inquiry data sheets.

4.11.1.4 The vendor shall specify optional tests and inspection procedures necessary to ensure that materials are satisfactory for the service. Such tests and inspections shall be listed in the proposal. The purchaser should consider specifying additional tests and inspections, especially for materials in critical service.

4.11.1.5 Selection of casing material shall be restricted by the limits imposed by 4.2.7 and 4.2.8.

4.11.1.6 Material that is notch-sensitive and prone to brittle fracture at ambient temperatures (e.g. ASTM A 515) shall not be used.

- **4.11.1.7** Materials exposed to Hydrogen-sulfide (H₂S) gas service as defined by NACE MR 0175 shall be in accordance with the requirements of NACE MR 0175. Ferrous materials not covered by NACE MR 0175 shall be limited to a yield strength not exceeding 620 MPa (90 000 psi) and a Rockwell hardness not exceeding HRC 22. Components that are fabricated by welding shall be stress relieved, if required, so that both the welds and the heat-affected zones meet the yield strength and hardness requirements. The purchaser shall specify on the data sheets the presence of H₂S in the process gas.

NOTE Shafts in compressors of between-bearing design can exceed the stated limits of yield strength and hardness because of requirements for higher strength at reduced shaft sections near couplings and because of the low levels of working stress in the portion of the shaft between bearings.

- **4.11.1.8** The purchaser shall specify the presence of any corrosive agents in the process gas, the process stream and the environment, including constituents that may cause stress corrosion cracking.

4.11.1.9 If parts made from austenitic stainless steels are exposed to a process gas or environmental conditions that promote corrosion, and they could be fabricated, hard-surfaced, repaired or overlaid by welding, then stabilized or low-carbon grades shall be used.

4.11.1.10 Austenitic steels shall not be used in services where stress corrosion cracking is a possibility.

NOTE Overlays or hard surface that contain more than 0,10 % carbon can sensitize both low-carbon and stabilized grades of austenitic stainless steel unless a buffer layer that is not sensitive to inter-granular corrosion is applied.

4.11.1.11 In hydrogen gas service at partial gauge pressures greater than 700 kPa (100 psi) or at concentrations greater than a molal percentage of 90 % at any pressure, impeller materials that have a yield strength in excess of 830 MPa (120 000 psi) or a hardness in excess of Rockwell HRC 34 are prohibited.

4.11.1.12 Materials, casting factors and the quality of any welding shall be in accordance with the pressure design code.

4.11.1.13 External parts that are subject to rotary or sliding motions (such as control linkage joints and adjusting mechanisms) shall be of corrosion-resistant materials suitable for the site environment.

4.11.1.14 Minor parts that are not identified (e.g. nuts, springs, washers, gaskets and keys) shall have corrosion resistance at least equal to that of specified parts in the same environment.

4.11.1.15 Bolting material for pressure joints shall be in accordance with the pressure design code.

4.11.1.16 If mating parts such as studs and nuts of austenitic stainless steel or materials with similar galling tendencies are used, they shall be lubricated with a suitable anti-seizure compound compatible with the process conditions.

NOTE Torque loading values will differ considerably with and without anti-seizure compound.

4.11.1.17 O-rings shall be compatible with all specified services. For high-pressure services, special consideration shall be given to the selection of O-rings that will not be damaged by rapid depressurization of the compressor.

4.11.2 Pressure-containing parts

4.11.2.1 The vendor shall specify on the data sheets (see annex A) the material grade of castings.

4.11.2.2 Welding of piping and pressure-containing parts, as well as any dissimilar metal welds and weld repairs, shall be performed and inspected by operators and using procedures qualified in accordance with the pressure design code.

4.11.2.3 The vendor shall be responsible for establishing weld repair procedures that are in accordance with the pressure design code and for the implementation of repairs in accordance with these procedures as well as for defect description, including post-repair heat treatment, if required, and non-destructive examination of repairs. Such procedures are subject to review by the purchaser before any repair is made.

4.11.2.4 Castings shall be sound and free from porosity, hot tears, shrink holes, blow holes, cracks, scale, blisters and similar injurious defects. Surfaces of castings shall be cleaned by sandblasting, shot-blasting, chemical cleaning, pickling or any other standard method. Mould parting fins and remains of gates and risers shall be chipped, filed or ground flush.

4.11.2.5 The use of chaplets in pressure castings shall be held to a minimum. The chaplets shall be clean and corrosion free (plating permitted) and of a composition compatible with the casting.

4.11.2.6 Cast grey iron or nodular iron castings shall not be repaired by welding, peening, burning or impregnating.

4.11.2.7 Weldable grades of steel castings may be repaired by welding, using a qualified welding procedure in accordance with the pressure design code.

4.11.2.8 Cast grey iron or nodular iron may be repaired by plugging within the limits specified in the selected materials specification. The holes drilled for plugs shall be carefully examined, using liquid penetrant, to ensure that all defective material has been removed. All repairs that are not covered by the specification shall be subject to the purchaser's approval.

4.11.2.9 Fully enclosed cored voids, including voids closed by plugging, shall not be used.

4.11.2.10 Nodular iron castings shall be in accordance with the pressure design code, or a standard agreed by the purchaser (e.g. ASTM A 395).

4.11.2.11 Pressure-containing casings made of wrought materials or combinations of wrought and cast materials shall conform to the following conditions.

- a) Plate edges shall be inspected by magnetic particle or liquid penetrant examination in accordance with the pressure design code.
 - b) Accessible surfaces of welds shall be inspected by magnetic particle or liquid penetrant examination after back chipping or gouging and again after stress relieving.
 - c) Pressure-containing welds, including welds of the case to horizontal and vertical joint flanges, shall be full penetration (complete joint) welds unless otherwise approved by the purchaser prior to any fabrication. For exceptions see 4.4.3.
 - d) Fabricated casings, including main nozzles, shall be post weld heat treated, regardless of thickness. For exceptions see 4.4.3.
 - e) Welded casings shall be examined radiographically or ultrasonically (see 4.11.4.). All pressure-containing welds shall be examined in accordance with the pressure design code. Requirements for additional examination shall be mutually agreed upon by the vendor and the purchaser.
- **4.11.2.12** If specified, proposed connection designs shall be submitted to the purchaser for approval before fabrication. The drawings shall show weld designs, size, materials and both pre- and post-weld heat treatments.

4.11.3 Low temperature

- For operating temperatures below $-30\text{ }^{\circ}\text{C}$ ($-20\text{ }^{\circ}\text{F}$), or if specified for other low ambient temperatures, steels shall have, at the lowest specified temperature, an impact strength sufficient to qualify under the minimum Charpy V-notch impact energy requirements of the pressure design code. For materials and thickness not covered by the code, the purchaser shall specify the requirements on the data sheets.

4.11.4 Material inspection of pressure-containing parts

4.11.4.1 Regardless of these generalized limits, it shall be the vendor's responsibility to review the design limits of all castings in the event that more stringent requirements are specified.

4.11.4.2 If radiographic, ultrasonic, magnetic particle, or liquid penetrant inspection of welds or materials is required or specified, the following procedures and acceptance criteria shall apply, except as noted (see 6.2.2.1.2).

- a) Radiographic examination shall be in accordance with the pressure design code. Spot radiography shall consist of a minimum of one 150 mm (6 in) spot radiograph for each 7,5 m (25 ft) of weld on each casing. As a minimum one spot radiograph is required for each welding procedure and welder used for pressure containing welds.
- b) Ultrasonic examination shall be in accordance with the pressure design code.
- c) Magnetic particle examination shall be in accordance with the pressure design code. Linear indications shall be considered relevant only if the major dimension exceeds 1,5 mm ($1/16$ in). Individual indications that are separated by less than 1,5 mm ($1/16$ in) shall be considered continuous.
- d) Liquid penetrant examination shall be in accordance with the pressure design code.

4.11.4.3 Cast steel casing parts shall be examined by magnetic particle methods. If magnetic particle inspection as described in ASTM E 709 is required, acceptability of defects shall be based on a comparison with the photographs in ASTM E 125. For each type of defect, the degree of severity shall not exceed the limits specified in Table 2. Defects that exceed the limits imposed in Table 2 shall be cleaned out to meet the quality standards cited above, as determined by additional magnetic particle inspection before repair welding.

Table 2 — Maximum severity of defects in casings

Type	Defect	Degree
I	Linear discontinuities	0 (None acceptable)
II	Shrinkage	2
III	Inclusions	2
IV	Chills and chaplets	1
V	Porosity	1
VI	Welds	1

4.11.5 Impellers

4.11.5.1 All accessible areas of welds on welded impellers shall be inspected by magnetic particle or liquid penetrant examination.

4.11.5.2 Cast impellers shall be inspected by radiographic or ultrasonic means prior to finish machining. Details of inspection techniques and acceptance criteria shall be mutually agreed upon by the vendor and the purchaser.

4.11.5.3 Brazed impellers shall be inspected by ultrasonic means. Details of inspection techniques and acceptance criteria shall be mutually agreed by the vendor and the purchaser.

4.11.5.4 After the overspeed test described in 6.3.3, each impeller shall be examined all over by means of magnetic particle or liquid penetrant methods.

4.12 Nameplates and rotation arrows

4.12.1 A nameplate shall be securely attached at a readily visible point on the equipment and on any other major piece of auxiliary equipment.

4.12.2 Rotation arrows shall be cast in, or attached to, each major item of rotating equipment. Nameplates and rotation arrows (if attached) shall be of austenitic stainless steel or of nickel copper alloy (Monel or its equivalent). Attachment pins shall be of the same material.

4.12.3 The purchaser's item number, the vendor's name, the machine's serial number and the machine's size and type as well as its minimum and maximum allowable working pressures and temperatures, hydrostatic test pressures, and critical speeds, shall appear on the machine's nameplate.

4.12.4 Any lateral critical speeds determined on the running tests shall be stamped on the nameplate followed by the word test. Critical speeds that are predicted by calculation up to and including the critical speed above trip speed and are not identifiable by test shall be stamped on the nameplate and noted as calculated value.

5 Accessories

5.1 Drivers

- **5.1.1** The type of driver shall be specified by the purchaser. The driver shall be sized to meet the maximum specified operating conditions, including external gear or coupling losses or both, and shall be in accordance with applicable specifications, as stated in the inquiry and order. The driver shall be suitable for satisfactory operation under the utility and site conditions specified by the purchaser.
- **5.1.2** Anticipated process variations that may affect the sizing of the driver (such as changes in the pressure, temperature or properties of the fluid handled, as well as special plant start-up conditions) shall be specified by the purchaser.
- **5.1.3** The starting conditions for the driven equipment shall be specified by the purchaser and the starting method shall be mutually agreed upon by the purchaser and the vendor. The driver's starting torque capabilities shall exceed the speed torque requirements of the driven equipment.

5.1.4 Steam turbine drivers shall be in accordance with ISO 10437. Steam turbine drivers shall be sized to continuously deliver 110 % of the maximum power (including gear, fluid coupling or other losses, as applicable) required for the purchaser's specified conditions while operating at a corresponding speed with the specified steam conditions.

5.1.5 For motor-driven units, the motor nameplate rating (exclusive of the service factor) shall be at least 110 % of the greatest power (including gear, fluid coupling or other losses, as applicable) required for any of the specified operating conditions. Consideration should be given to starting the compressor at the normal suction pressure. Compressors driven by induction motors shall be rated at the actual motor speed for the rated load condition.

If variations in operating conditions (e.g. as molar mass) are expected the purchaser should consider specifying a higher margin.

- **5.1.6** The motor's starting torque requirements shall be met at a reduced voltage specified by the purchaser and the motor shall accelerate to full speed within a period of time agreed upon by the purchaser and the vendor.

NOTE For most applications the starting voltage is typically 80 % of the normal voltage and the time required to accelerate to full speed is generally less than 30 s.

5.1.7 Gas turbine drivers shall conform to ISO 3977-5 and shall be sized as mutually agreed upon by the purchaser and the vendor.

5.1.8 Speed increasers and reducers shall be in accordance with ISO 13691. Epicyclic gears may be used with the purchaser's approval.

5.1.9 The trip speed of variable speed drivers shall be as given in Table 3.

Table 3 — Trip speed values

Driver type	Trip speed (percentage of maximum continuous speed)
Steam Turbine	110
Gas Turbine	105
Variable speed motor	105
Reciprocating engine	110

5.2 Couplings and guards

5.2.1 Unless otherwise specified, the compressor vendor shall furnish all couplings and guards for the entire compressor train, including gears if they are part of the train. The vendor shall arrange for complete machining of all couplings halves, shall mount the compressor coupling half and shall arrange for mounting of the drive train half, couplings.

- **5.2.2** Couplings shall be in accordance with ISO 10441. The make, type, and mounting arrangement of the couplings shall be agreed upon by the purchaser and the vendors of the driver and driven equipment. Guards shall comply with the specified national code.

5.2.3 The coupling-to-shaft juncture shall be designed and manufactured to be capable of transmitting power at least equal to the power rating of the coupling.

- **5.2.4** If uncoupled operation is specified, idling adaptors (solo plates) or coupling mass simulators in accordance with ISO 10441, or both, shall be provided as necessary to enable the driver and any gearbox or drive-through casing to be run uncoupled.
- **5.2.5** Plug and ring gauges supplied shall be in accordance with ISO 10441.

5.3 Mounting plates

5.3.1 General

- **5.3.1.1** The equipment shall be furnished with sole plates or a baseplate as specified on the data sheets (see annex A).

5.3.1.2 In the following, the term "mounting plate" refers to both baseplates and sole plates.

- a) Axial, lateral and vertical jackscrews shall be provided for all equipment in the compressor train. Vertical jackscrews shall be arranged to prevent marring of shimming surfaces.
 - b) Compressor supports shall be provided with austenitic stainless steel shim packs, 3 mm to 15 mm ($\frac{1}{8}$ in to $\frac{1}{2}$ in) thick, with jack screws for easy removal or addition of shims. All shims shall straddle hold-down bolts and jackscrews.
 - c) The upper and lower surfaces of bearing pedestals and mounting plates shall be machined parallel.
 - d) If centreline supports are provided, they shall be designed and manufactured to permit the machine to be moved using the horizontal jackscrews.
 - e) Anchor bolts shall not be used to fasten machinery to the mounting plates.
 - f) Mounting plates shall not be drilled for equipment to be mounted by others. Mounting plates intended for installation on concrete shall be supplied with levelling screws. Mounting plates that are to be grouted shall have 50 mm (2 ") radiused outside corners (in the plan view). See Figures 10 and 11.
 - g) Anchor bolts shall be furnished by the purchaser.
 - h) Fasteners for attaching the components to the mounting plates and jackscrews for levelling the pedestal sole plates shall be supplied by the vendor.
 - i) The equipment feet shall be drilled with pilot holes that are accessible for use in final doweling.
- **j)** If epoxy grout is specified on the data sheets, the vendor shall precoat all the grouting surfaces of the mounting plates with a catalyzed epoxy primer applied to degreased near-white metal. The purchaser shall specify the primer and the method of application.
 - k) Mounting surfaces that are not to be grouted shall be coated with a rust-preventive immediately after machining.

Dimensions in millimetres

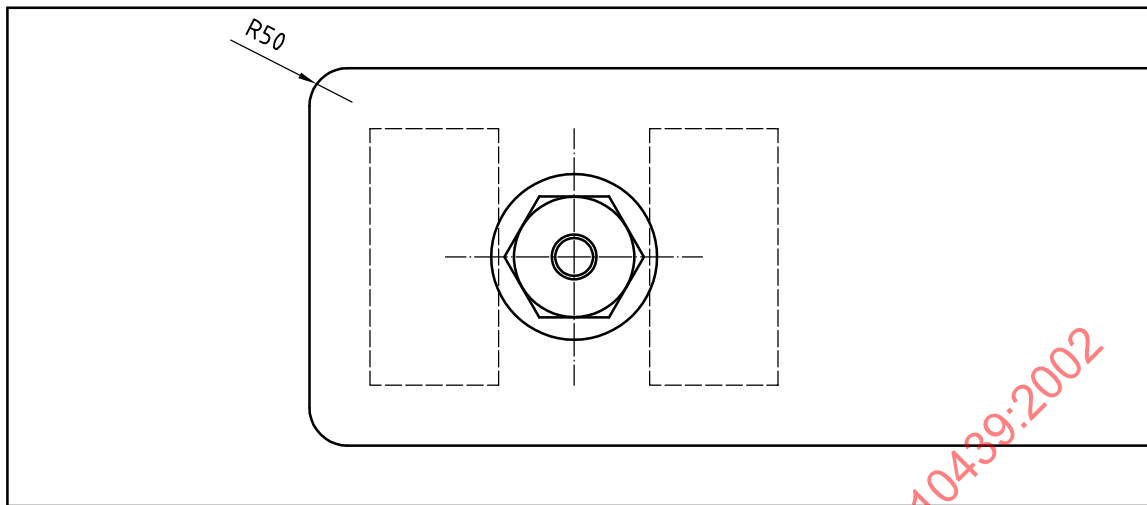
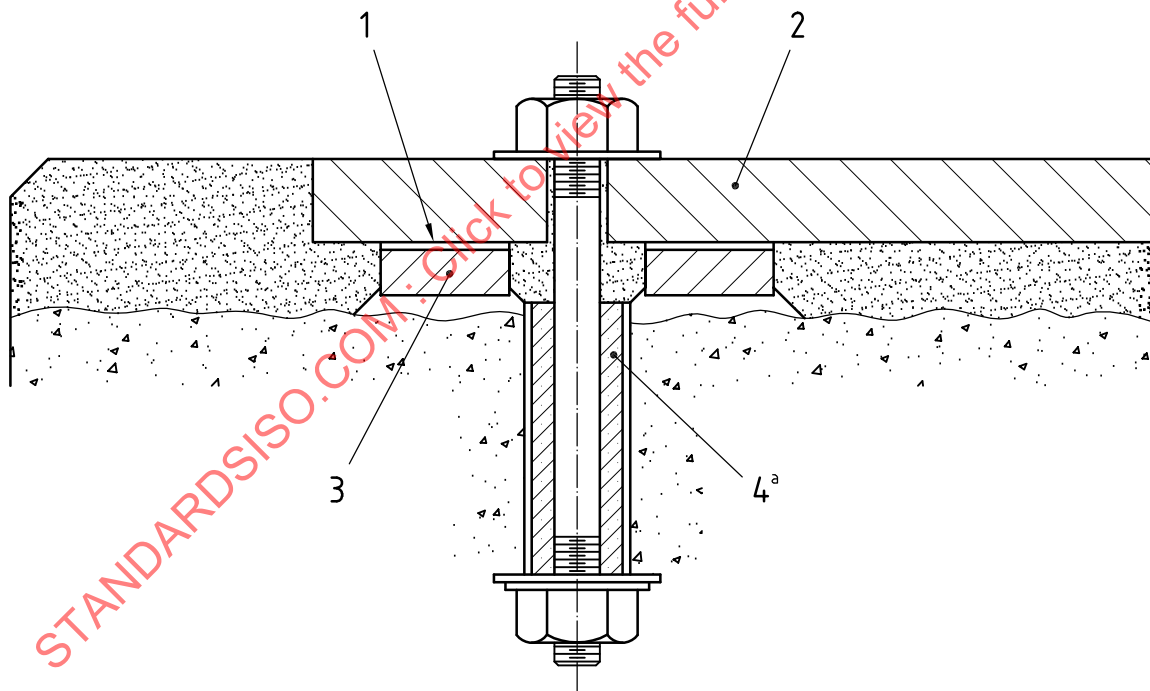

Figure 10 — Sole plate arrangement (top view)



Key

- 1 Shim pack
- 2 Sole plate
- 3 Sub-sole plate
- 4 Typical anchor bolt sleeve

^a These areas shall be filled with grout, which is then left to set, after which the normal sole plate areas shall be grouted.

Figure 11 — Sole plate arrangement (cross-section)

5.3.2 Baseplate

5.3.2.1 A baseplate shall be a single fabricated steel unit unless the purchaser and the vendor mutually agree that it may be fabricated in multiple sections. Multiple section baseplates shall have machined and doweled mating surfaces to ensure accurate field reassembly.

NOTE A baseplate with a nominal length of more than 12 m (40 ft) or a nominal width of more than 3,5 m (12 ft) might have to be fabricated in multiple sections because of shipping restrictions.

- **5.3.2.2** If specified, the baseplate shall be provided with levelling pads or targets protected with removable covers. The pads or targets shall be accessible for field levelling after installation, with the equipment mounted and the baseplate on the foundation.
- **5.3.2.3** If specified, the baseplate shall be suitable for column mounting (i.e. of sufficient rigidity to be supported at specific points) without continuous grouting under structural members. The baseplate design shall be mutually agreed upon by the purchaser and the vendor.

5.3.2.4 The baseplate shall be provided with lifting lugs for at least a four-point lift. Lifting the baseplate complete with all equipment mounted shall not permanently distort or otherwise damage the baseplate or the machinery mounted on it.

5.3.2.5 The bottom of the baseplate between structural members shall be open. If the baseplate is installed on a concrete foundation, accessibility shall be provided for grouting under all load-carrying structural members. The mounting pads on the bottom of the baseplate shall be in one plane in order to permit use of a single-level foundation.

5.3.2.6 Unless otherwise specified, non-skid decking covering all walk and work areas shall be provided on the top of the baseplate.

5.3.2.7 Oil reservoirs shall be separate from the baseplate (see ISO 10438) unless otherwise approved by the purchaser.

- **5.3.2.8** If specified, the baseplate shall be extended as necessary to support the driver, other compressors, and gear units or the control panel or both.

5.3.3 Sole plates and sub sole plates

5.3.3.1 If sole plates are specified, they shall meet the following requirements, in addition to those of 5.3.2.

- a) Sole plates shall be larger than the individual mounting pad area for each mating pad.
- b) Working clearance for hold-down bolts and levelling screws shall be provided.
- c) Sole plates shall be steel plates thick enough to transmit the expected loads from the equipment feet to the foundation but in no case shall they be less than 40 mm (1,5 in) thick. See Figures 10 and 11.
- d) Corners shall be rounded to a minimum 50 mm (2 in) radius in the plan view (see Figure 10).

- **5.3.3.2** If specified, sub-sole plates shall be furnished. They shall be steel plates a minimum of 25 mm (1 in) thick having a mating surface finish that matches the sole plates.

5.4 Controls and instrumentation

5.4.1 General

- **5.4.1.1** The purchaser shall outline in the inquiry the control philosophy to be followed. The vendor shall provide sufficient compressor performance data (in accordance with clause 7) to enable the purchaser to properly design a control system for start-up operation, for all specified operating conditions and shutdowns, and for surge prevention. If requested by the purchaser, the vendor shall review the purchaser's overall compressor control system for compatibility with vendor furnished control equipment.

- **5.4.1.2** Instrumentation and installation shall conform to all detailed specifications in the purchaser's inquiry. If no detailed specifications are furnished, instrumentation and installation shall be in accordance with ISO 10438.
- 5.4.1.3** If applicable, controls and instrumentation shall be in accordance with API RP 550.
- 5.4.1.4** Unless otherwise specified, controls and instrumentation shall be suitable for outdoor installation.
- 5.4.1.5** Instrument and electrical wiring shall be installed, protected and shall comply with the relevant standards, and shall be designed so that it can be easily removed without damage or located so as not to hamper removal of bearings, seals or the compressor internals.
- 5.4.1.6** If operation from a Distributed Control System (DCS) is specified, the vendor shall indicate all signals for operating the machinery from the DCS.
- **5.4.1.7** If specified, a dynamic simulation study shall be carried out to verify the satisfactory behaviour of the anti-surge protection system and process control system under all operating conditions.

5.4.2 Control systems

- **5.4.2.1** The compressor may be controlled on the basis of inlet pressure, discharge pressure, flow or some combination of these parameters. This may be accomplished by suction or discharge throttling, variable inlet guide vanes, speed variation, discharge blowoff (if a constant-speed driver is used) or a cooled bypass from discharge to suction. The control system may be mechanical, pneumatic, hydraulic electric or any combination of these. The system may be manual, or it may be automatic with a manual override. The purchaser shall specify the source of the control signal, its sensitivity and range, and the equipment to be furnished by the vendor.

NOTE A combination of control modes could be required on drives with a limited speed range and on multiservice or multi-stream applications.

- **5.4.2.2** If specified, an anti-surge system shall be provided.

NOTE Anti-surge systems are generally required to prevent operation in unstable regions that might cause damage to the compressor.

- **5.4.2.3** If the driver is an electric motor, and automatic capacity control with automatic override control is specified, the override control shall prevent overloading the motor. The override control shall limit motor current to avoid overcurrent tripping of the motor. Such controls shall include

- a) a motor current indicator at the compressor control panel, and
- b) a current transformer/transducer in the motor switch gear to generate a milliampere signal for the control current indicator.

- **5.4.2.4** For a constant-speed drive, the control signal shall actuate either a purchaser-furnished control valve or the adjustable inlet guide vanes furnished by the vendor as an integral part of the compressor, as specified. In the later case, the vendor shall also furnish a guide vane positioner compatible with the type of control signal specified by the purchaser and shall include a hand wheel or other means of local manual override during operation. A direct-driven vane position indicator shall be provided that is visible during operation of the machine.

5.4.2.5 For a variable-speed drive, the control signal shall act to adjust the set point of the driver's speed control system. Unless otherwise specified, the control range shall be from the maximum continuous speed to 95 % of the minimum speed required for any specified operating case, or 70 % of the maximum continuous speed, whichever is the lower.

5.4.2.6 The full range of the purchaser's specified control signal shall correspond to the required operating range of the driven equipment. Unless otherwise specified, the maximum control signal shall correspond to the maximum continuous speed or the maximum flow.

5.4.3 Instrument and control panels

- **5.4.3.1** If specified, a panel shall be provided that includes all panel-mounted instruments for the driven equipment and the driver. Such panels shall be designed and fabricated in accordance with the purchaser's description. The purchaser shall specify whether the panel is to be free-standing, located on the base of the unit, or in another location. The instruments on the panel shall be clearly visible to the operator from the driver control point. A lamp test push button shall be provided. The instruments to be mounted on the panel shall be specified by the purchaser on the data sheets (see annex A).
- **5.4.3.2** Panels shall be completely piped and wired, requiring only connection to the purchaser's external piping and wiring circuits. If more than one wiring point is required on a unit for control or instrumentation, the wiring to each switch or instrument shall be provided from a terminal box with terminal posts mounted on the unit (or its base, if any). The purchaser shall specify whether the wiring protection shall be by conduit or by armoured cabling. All leads and posts on terminal strips, switches, and instruments shall be tagged for identification.

5.4.4 Instrumentation

5.4.4.1 General

5.4.4.1.1 Unless otherwise specified, all leads on terminal strips, switches and instruments shall be permanently tagged for identification. All terminal boards in junction boxes and control panels shall have at least 20 % spare terminal points.

- **5.4.4.1.2** If specified, air purging shall be used to avoid moisture problems, even if weatherproof and watertight housings are used. Purge air shall be clean and dry, conforming to ISA RP 12.4 type X and Y and NFPA 496.

5.4.4.2 Thermometers and temperature gauges

5.4.4.2.1 Dial-type temperature gauges shall be heavy-duty and corrosion-resistant. They shall be at least 125 mm (5 in) in diameter and bimetallic or liquid-filled.

NOTE Black printing on a white background is standard for gauges.

5.4.4.2.2 The sensing elements of thermometers and temperature gauges shall be in the flowing fluid.

5.4.4.3 Thermowells

Thermometers and temperature gauges that are in contact with flammable or toxic fluids, or that are located in pressurized or flooded lines, shall be furnished with austenitic stainless steel separable-flange type, solid-bar thermowells, at least 19 mm ($\frac{3}{4}$ in) in diameter.

5.4.4.4 Thermocouples and resistance temperature detectors

If practicable, the design and location of thermocouples and resistance temperature detectors, except bearing temperature sensors (see 4.7.1.2), shall permit replacement while the unit is operating. The lead wires of thermocouples and resistance temperature detectors shall be installed as continuous leads between the thermowell or detector and the terminal box. Conduit or armoured cable runs from thermocouple heads to a pull box or boxes located on the base plate shall be provided.

5.4.4.5 Pressure gauges

- Pressure gauges (not including built-in instrument air gauges), unless otherwise specified, shall be furnished with Type 316 stainless steel bourdon tubes and stainless steel movements, 100 mm (4½ in) dials [160 mm dials for the range over 5 500 kPa (800 psi)] and DN 12 (NPS ½) pipe-thread, male, alloy steel connections. If specified, oil filled gauges shall be furnished in locations subject to vibration. Gauge ranges shall preferably be selected so that the normal operating pressure is at the middle of the gauge's range. In no case, however, shall the maximum reading on the dial be less than the applicable relief valve setting plus 10 %. Each pressure gauge shall be provided with a device, such as a disk insert or blowout back, designed to relieve excess case pressure.

NOTE Black printing on a white background is standard for gauges.

5.4.4.6 Solenoid valves

5.4.4.6.1 Direct solenoid-operated valves shall be used only in clean, dry instrument air service, shall have Class F insulation or better, and shall have a continuous service rating. If required for other services, the solenoid shall act as a pilot valve to pneumatic valves, hydraulic valves and the like.

5.4.4.6.2 Solenoid valves shall not be used in continuous services that may affect normal operations, such as fuel controls. They may be used in intermittent instrument services such as starting cycle controls.

5.4.5 Alarms and shutdowns

5.4.5.1 General

- **5.4.5.1.1** Each alarm switch and each shutdown switch shall be furnished in a separate housing located to facilitate inspection and maintenance. Hermetically sealed, single-pole, double-throw switches with a minimum capacity of 5 A at 120 V AC shall be used. Unless otherwise specified, mercury switches shall not be used. If specified, the vendor shall furnish sensors and transmitters for necessary alarms and shutdown functions. Field instruments shall be of the electronic transmitter type, with analog signals for interface to the control system. For the compressor shutdown functions, separate sensors and transmitters shall be used. For control and alarm functions, combined sensors and transmitters may be used.

5.4.5.1.2 Unless otherwise specified, electric switches that open (de-energize) to alarm and trip shall be furnished by the vendor.

5.4.5.1.3 The sequence of alarm and shutdown operation shall be the following.

- a) Any alarm or shutdown condition shall be initiated by the action of locally mounted contacts, unless transmitters are used.
- b) Alarm and shutdown indications shall consist of a corresponding panel light illumination and the sounding of a horn.
- c) Acknowledgement of the alarm or shutdown condition, or both, shall be accomplished by operating a common horn-silencing push button suitably located on the panel. This shall silence the horn.
- d) After the alarmed field condition has been corrected, the corresponding panel alarm light shall remain lit until a common panel mounted reset push button is operated (manual reset). In the interim, any additional field alarm condition or conditions shall again sound the horn and illuminate the corresponding additional panel light or lights.
- e) Shutdown panel lights shall contain a first-out feature (i.e. only the first shutdown light shall be illuminated). After a shutdown occurs, operation of the reset push button shall be required before the unit can be restarted.

5.4.5.1.4 Connections shall be provided to actuate a remote alarm whenever any of the locally displayed compressor alarms or shutdowns operate.

5.4.5.2 Alarm and trip devices

5.4.5.2.1 Alarm and trip device settings shall not be adjustable from outside the housing. Alarm and trip devices shall be arranged to permit testing of the control circuit, including, if possible, the actuating element, without interfering with normal operation of the equipment. The vendor shall provide a clearly visible light on the panel to indicate when trip circuits are in a test bypass mode. Unless otherwise specified, shutdown systems shall be provided with switches or another suitable means to permit testing without shutting down the unit.

5.4.5.2.2 Pressure sensing elements shall be of austenitic stainless steel. Low-pressure alarms shall be equipped with a valved bleed or vent connection to allow controlled depressurizing so that the operator can note

the alarm set pressure on the associated pressure gauge. High-pressure alarms shall be equipped with valved test connections so that a portable test pump can be used to raise the pressure.

5.4.5.3 Removal of instruments and controls

All instruments and controls other than shutdown sensing devices shall be installed with sufficient valving to permit their removal while the system is in operation.

5.4.5.4 Housings for arcing switches

Attention is called to the requirements of 4.1.15 concerning the characteristics of housings for arcing type switches outlined in the applicable codes.

5.4.6 Electrical systems

- **5.4.6.1** The characteristics of electrical power supplies for motors, heaters and instrumentation shall be specified by the purchaser. A pilot light shall be provided on the incoming side of each supply circuit to indicate that the circuit is energized. The pilot lights shall be installed on the control panels.
- **5.4.6.2** Electrical equipment located on the unit or on any separate panel shall be suitable for the area classification specified (see 4.1.15). Electrical starting and supervisory controls may be either alternating or direct current.
- 5.4.6.3** Power and control wiring within the confines of the base plate shall be resistant to heat, moisture and abrasion. Stranded conductors shall be used within the confines of the base plate and in other areas subject to vibration. Measurement and remote control panel wiring may be solid-conductor. Where rubber insulation is used, a neoprene or equivalent high-temperature thermoplastic sheath shall be provided for insulation protection. Wiring shall be suitable for environmental temperatures.
- 5.4.6.4** Unless otherwise specified, all leads on terminal strips, switches and instruments shall be permanently tagged for identification. All terminal boards in junction boxes and control panels shall have at least 20 % spare terminal points.
- 5.4.6.5** To facilitate maintenance, liberal clearances shall be provided for all energized parts (such as terminal blocks and relays) on equipment. The clearances required for 600 V service shall also be provided for lower voltages. To guard against accidental contact, enclosures shall be provided for all energized parts.
- **5.4.6.6** Electrical materials, including insulation, shall be corrosion-resistant and nonhygroscopic as far as possible. If specified for a tropical location, materials shall be given the following treatments:
 - parts (such as coils and windings) shall be protected from fungus attack;
 - unpainted surfaces shall be protected from corrosion by plating or another suitable coating.
- **5.4.6.7** The purchaser shall specify whether control, instrumentation and power wiring (including thermocouple leads) within the limits of the base plate shall be installed in rigid conduit or armoured cabling installed in cable trays and boxes, properly bracketed to minimize vibration, and isolated or shielded to prevent interference between voltage levels. Conduits and armoured cables may terminate (and in the case of temperature, element heads shall terminate) with a flexible metallic conduit long enough to permit access to the unit for maintenance without removal of the conduit. If thermocouple heads are to be exposed to temperatures above 60 °C (140 °F), they shall be installed with suitable heat protection.
- 5.4.6.8** Power and control wiring terminations shall be liquid-tight and in accordance with applicable national regulations, taking into account the area classification.

5.4.7 Vibration, position and bearing temperature detectors

5.4.7.1 Unless otherwise specified, vibration and axial position transducers shall be supplied, installed and calibrated in accordance with API 670.

- **5.4.7.2** If specified, vibration and axial position monitors shall be supplied and calibrated in accordance with API 670.
- **5.4.7.3** If specified, a bearing temperature monitor shall be supplied and calibrated according to API 670. See 4.7.1.2.
- **5.4.7.4** If specified, acceleration-based vibration transducers shall be supplied, installed and calibrated in accordance with API 670.
- **5.4.7.5** If specified, monitors shall be supplied, installed and calibrated in accordance with API 670.

5.5 Piping and appurtenances

5.5.1 General

5.5.1.1 All auxiliary piping provided by the vendor shall be in accordance with ISO 10438.

5.5.1.2 Auxiliary systems are those piping systems in the following services:

- instrument and control air;
- lubricating oil;
- control oil;
- seal oil;
- cooling water;
- balance gas;
- reference gas;
- buffer gas;
- seal gas;
- separation gas;
- drains.

NOTE See 4.4 for casing connections.

- **5.5.1.3** If a base plate has been specified, the vendor shall furnish all piping systems, including mounted appurtenances, located within its confines. The piping shall terminate with flanged connections at the edge of the base plate. The purchaser shall furnish only the interconnecting piping between equipment groupings and off-base facilities. If sole plates are specified, the extent of the piping system supplied by the vendor shall be agreed between the vendor and the purchaser.

5.5.1.4 Instrument lines for gas or oil shall be provided with shutoff valves at the points of measurement.

- **5.5.1.5** If specified, a liquid injection manifold shall be supplied. It shall include a throttle valve, an armoured flow meter, a check valve, a pressure indicator and a block valve for each injection point.

- **5.5.1.6** If gas manifolds for buffer gas, seal gas or separation gas are specified, the required components such as valves, flow meters, check valves, pressure indicators, controllers and control valves shall be furnished by the vendor.

5.5.1.7 Provision for bypassing the bearings (and seals, if applicable) of compressor and drivers during oil system flushing operations shall be provided.

5.5.2 Instrument piping

5.5.2.1 Unless otherwise specified, the vendor's standard instrument tubing and fittings shall be supplied.

5.5.2.2 Connections on equipment and piping for pressure instruments and test points shall be in accordance with ISO 10438. Beyond the initial 19 mm ($\frac{3}{4}$ in) isolating valve, DN 12 (NPS $\frac{1}{2}$) piping, valves and fittings may be used. If convenient, a common connection may be used for remotely mounted instruments that measure the same pressure. Separate secondary 12 mm ($\frac{1}{2}$ in) isolating valves are required for each instrument on a common connection. If a pressure gauge is to be used for testing pressure alarm or shutdowns switches, common connections are required for the pressure gauge and switches.

5.5.3 Process piping

- **5.5.3.1** The extent of process piping to be supplied by the vendor shall be specified by the purchaser.
- **5.5.3.2** If specified, the vendor shall review all piping, appurtenances (intercoolers, after-coolers, separators, knockout drums, air intake filters and expansion joints), and vessels immediately upstream and downstream of the equipment and supports. The purchaser and the vendor shall mutually agree on the scope of review.

5.6 Special tools

5.6.1 If special tools and fixtures are required to disassemble, assemble or maintain the unit, they shall be included in the quotation and furnished as part of the initial supply of the machine. For multi-unit installations, the requirements for quantities of special tools and fixtures shall be mutually agreed upon by the purchaser and the vendor. These or similar special tools shall be used during shop assembly and post-test disassembly of the equipment.

5.6.2 If special tools are provided, they shall be packaged in separate, rugged boxes and marked "Special tools for (tag/item)". Each tool shall be stamped or tagged to indicate its intended use.

6 Inspection, testing and preparation for shipment

6.1 General

6.1.1 After advance notification of the vendor by the purchaser, the purchaser's representative shall have entry to all vendor and subvendor plants where manufacturing, testing or inspection of the equipment is in progress.

6.1.2 The vendor shall notify subvendors of the purchaser's inspection and testing requirements.

6.1.3 The vendor shall provide sufficient advance notice to the purchaser before conducting any inspection or test that the purchaser has specified be witnessed or observed (see 6.1.4.2 and 6.1.4.3).

- **6.1.4** The purchaser shall specify the extent of purchaser participation in the inspection and testing.
 - a) The purchaser and the vendor shall meet to coordinate manufacturing hold points and inspector's visits.
 - b) "Witnessed" means that a hold shall be applied to the production schedule and that the inspection or test shall be carried out with the purchaser or purchaser's representative in attendance. For mechanical running or performance tests, this requires written notification of a successful preliminary test.

- c) "Observed" means that the purchaser shall be notified of the timing of the inspection or test. However the inspection or test shall be performed as scheduled and if the purchaser or purchaser's representative is not present, the vendor shall proceed to the next step. (The purchaser should expect to be in the factory longer than for a witnessed test).

6.1.5 Equipment for the specified inspection and tests shall be provided by the vendor.

- **6.1.6** If specified, the purchaser's representative, the vendor's representative or both shall indicate compliance in accordance with the inspector's checklist (see annex H) by initialing, dating and submitting the completed form before shipment.

6.2 Inspection

6.2.1 General

6.2.1.1 The vendor shall keep the following data available for at least five years for examination by the purchaser or his representative upon request:

- a) necessary certification of materials, such as mill test reports;
- b) purchaser specifications for all items on bills of materials;
- c) test data for verifying that the requirements of the specifications have been met;
- d) fully identified records of all heat treatment, whether performed in the normal course of manufacture or as part of a repair procedure;
- e) results of quality control tests and inspections;
- f) running test data (see 6.3.4);
- g) final assembly maintenance and running clearances.

6.2.1.2 Pressure containing parts shall not be painted until the specified hydrotest is completed.

- **6.2.1.3** The purchaser shall specify

- a) parts that are to be subjected to surface and subsurface examination, and
- b) the type of examination required, such as magnetic particle, liquid penetrant, radiographic and ultrasonic examination.

6.2.1.4 During assembly of the compressor and before testing, each component (including cast-in passages of these components) and all piping and appurtenances shall be cleaned by pickling or by another appropriate method to remove foreign materials, corrosion products and mill scale.

- **6.2.1.5** If specified, the purchaser may inspect for cleanliness of the equipment and all piping and appurtenances furnished by or through the vendor before heads are welded to vessels, openings in vessels or exchangers are closed or piping is finally assembled.
- **6.2.1.6** If specified, the hardness of parts, welds and heat-affected zones shall be verified as being within the allowable values by testing of the parts, welds or heat-affected zones. The method, extent, documentation and witnessing of the testing shall be mutually agreed upon by the purchaser and the vendor.

6.2.2 Material inspection

6.2.2.1 General

- **6.2.2.1.1** If radiographic, ultrasonic, magnetic particle or liquid penetrant inspection of welds or materials is specified, the recommended practices in 6.2.2.2 to 6.2.2.5 shall apply unless other procedures are specified or agreed by the purchaser. Cast iron may be inspected in accordance with 6.2.2.4 and 6.2.2.5. Welds, cast steel and wrought material may be inspected in accordance with 6.2.2.2. to 6.2.2.5. The material inspection of pressure-containing parts is covered in 4.11.2 and 4.11.4, and impellers are dealt with in 4.11.5.

The examination techniques concerned are applicable to great varieties of sizes and shapes of materials and widely varying examination requirements. Since the specification for the actual component being inspected depends on metallurgy, component configuration and method of manufacture, specific procedures and acceptance standards for the application should be covered by written standards, developed by the manufacturer for the specific application.

- **6.2.2.1.2** Acceptance criteria for 6.2.2.2 to 6.2.2.5 shall be mutually agreed upon between the purchaser and the vendor.

6.2.2.2 Radiographic inspection

Radiography shall be based upon the procedures of ASTM E 94.

6.2.2.3 Ultrasonic inspection

Ultrasonic inspection shall be based upon the procedures of ASTM A 609 (castings), ASTM A 388 (forgings) or ASTM A 578 (plate).

6.2.2.4 Magnetic particle inspection

Both wet and dry methods of magnetic particle inspection shall be based upon the procedures of ASTM E 709.

6.2.2.5 Liquid penetrant inspection

Liquid penetrant inspection shall be based upon the procedures of ASTM E 165.

6.3 Testing

6.3.1 General

6.3.1.1 Equipment shall be tested in accordance with 6.3.2, 6.3.3, 6.3.4, and 6.3.5. Other tests that may be specified by the purchaser are described in 6.3.6.

NOTE See annex I for typical gas seal testing considerations.

6.3.1.2 At least six weeks before the first scheduled tests, the vendor shall submit to the purchaser, for review and comment, detailed procedures for all the running tests, including acceptance criteria for all monitored parameters.

6.3.1.3 The vendor shall notify the purchaser not less than five working days before the date the equipment will be ready for testing. If the testing is rescheduled, the vendor shall notify the purchaser not less than five working days before the new test date.

6.3.2 Hydrostatic test

6.3.2.1 Pressure-containing parts (including auxiliaries) shall be tested hydrostatically with liquid at a minimum of 1,5 times the maximum allowable working gauge pressure but not less than 140 kPa (20 psi) pressure.

6.3.2.2 Tests shall be maintained for a period of time sufficient to permit complete examination of parts under pressure. The hydrostatic test shall be considered satisfactory if neither leaks nor seepage through the casing or casing joint is observed for a minimum period of 30 min. Large, heavy castings may require that a longer testing period be agreed upon by the purchaser and the vendor. Seepage past internal closures required for testing of segmented cases and operation of a test pump to maintain pressure are acceptable.

6.3.2.3 The chloride content of liquids used to test austenitic stainless steel materials shall not exceed 50 µg/g. To prevent deposition of chlorides as a result of evaporative drying, all residual liquid shall be removed from tested parts at the conclusion of the test.

6.3.2.4 If the part tested is to operate at a temperature at which the strength of a material is below the strength of that material at room temperature, the hydrostatic test pressure shall be multiplied by a factor obtained by dividing the allowable working stress for the material at room temperature by that at operating temperature. The stress values used shall comply with the pressure design code. The pressure thus obtained shall then be the minimum pressure at which the hydrostatic test shall be performed. The data sheets shall list actual hydrostatic test pressures.

6.3.3 Impeller overspeed test

Each impeller shall be subjected to an overspeed test at not less than 115 % of maximum continuous speed for a minimum duration of 1 min. Impeller dimensions identified by the manufacturer as critical (e.g. bore, eye seal and outside diameter) shall be measured before and after each overspeed test. All such measurements and the test speeds shall be recorded and submitted for the purchaser's review following the test. Any permanent deformation of the bore or other critical dimension outside drawing tolerances might be cause for rejection.

6.3.4 Mechanical running test

6.3.4.1 Prior to testing

6.3.4.1.1 The contract shaft seals and bearings shall be used in the machine for the mechanical running test. The contract inner seal shall be subjected to design differential pressure during the test (not valid for tests under vacuum conditions, see 6.3.4.2.4). If permitted by the purchaser, the atmospheric breakdown bushing or bushings on an oil-buffered seal may be replaced with a test bushing. (Low-pressure mechanical testing may require greater than design clearance or fewer elements, or both, for proper heat removal).

6.3.4.1.2 All oil pressures, viscosities and temperatures shall be within the range of operating values recommended in the vendor's operating instructions for the specific unit being tested. Oil viscosity of test stand oil may be adjusted by temperature if different oil viscosity indexes are used. If it is proposed that the test oil temperatures be different from service temperatures, acceptance levels shall be agreed. Oil flow rates for each oil supply line shall be determined.

6.3.4.1.3 Test stand oil filtration shall be 10 µm (0,4 mil) nominal or better. Oil system components downstream of the filters shall meet the cleanliness requirements of ISO 10438 before any test is started.

6.3.4.1.4 All joints and connections shall be checked for tightness, and any leaks shall be corrected.

6.3.4.1.5 All warning, protective and control devices used during the test shall be checked, and adjustments shall be made as required.

6.3.4.1.6 Facilities shall be installed to prevent the entrance of oil into the compressor during the mechanical running test. These facilities shall be in operation throughout the test.

6.3.4.1.7 Testing with the contract coupling is preferred. If this is not practical, the mechanical running test shall be performed with coupling hub idling adapters in place, resulting in moments equal ($\pm 10\%$) to the moment of the contract coupling hub plus one half that of the coupling spacer. If all testing is completed, the idling adapters shall be furnished to the purchaser as part of the special tools (see 5.6).

6.3.4.1.8 All purchased vibration probes, transducers, oscillator demodulators and accelerometers shall be in use during the test. If vibration probes are not furnished by the compressor vendor, or if the purchased probes are

not compatible with shop readout facilities, then shop probes and readouts that meet the accuracy requirements of API 670 shall be used.

6.3.4.1.9 Shop test facilities shall include instrumentation with the capability of continuously monitoring and plotting revolutions per minute, peak-to-peak displacement and phase angle ($x-y-y$). Presentation of vibration displacement and phase marker shall also be by oscilloscope.

6.3.4.1.10 The vibration characteristics determined by the use of the instrumentation specified in 6.3.4.1.8 and 6.3.4.1.9 shall serve as the basis for the acceptance or rejection of the machine (see 4.9.5.6).

6.3.4.2 Test procedure

CAUTION — Care should be exercised when operating equipment at or near critical speeds.

6.3.4.2.1 Operate the equipment at speed increments of approximately 10 %, from zero to the maximum continuous speed, and run at the maximum continuous speed until bearings, "lube" oil temperatures and shaft vibrations have stabilized.

6.3.4.2.2 Increase to trip speed, and run the equipment for a minimum period of 15 min. For complete unit test with turbine drivers, increase the speed to within 2 % of trip speed if this requirement has been met.

6.3.4.2.3 Reduce the speed to the maximum continuous speed and run the equipment for 4 h.

6.3.4.2.4 Measure the inner seal oil leakage rate at each seal. Where, because of design considerations or test stand conditions, contract seal performance cannot be duplicated during the four-hour test, an additional reduced speed test or some other acceptable means of demonstrating contract seal performance shall be substituted (see 6.3.4.1.1). Any such alternate procedures shall be described in the vendor's proposed test plan and must be approved in advance by the purchaser.

- **6.3.4.2.5** If specified, "lube" oil and seal oil inlet pressures and temperatures shall be varied through the range permitted in the compressor operating manual. This shall be done during the four-hour test. This option, if specified, does not constitute a waiver of the other specified test requirements.

6.3.4.3 Requirements — During mechanical running testing

6.3.4.3.1 During the test, the mechanical operation of all equipment being tested and the operation of the test instrumentation shall be satisfactory. The measured unfiltered vibration shall not exceed the limits of 4.9.5.6 and shall be recorded throughout the operating speed range.

6.3.4.3.2 While the equipment is operating at maximum continuous speed and at other speeds that may have been specified in the test agenda, sweeps shall be made for vibration amplitudes at frequencies other than synchronous. As a minimum, these sweeps shall cover a frequency range from 5 % to 8 times the maximum continuous speed but not more than 90 000 r/min (1 500 Hz). If the amplitude of any discrete, nonsynchronous vibration exceeds 20 % of the allowable vibration as defined in 4.9.5.6, the purchaser and the vendor shall mutually agree on requirements for any additional testing and on the equipment's suitability for shipment.

- **6.3.4.3.3** Plots showing synchronous vibration amplitude and phase angle versus speed for acceleration and deceleration shall be made before and after the four-hour run. Plots shall be made of both the filtered (one per revolution) and unfiltered vibration levels. If specified, these data shall also be furnished in polar form. The speed range covered by these plots shall be zero to the specified driver trip speed.

6.3.4.3.4 The mechanical running test shall verify that lateral critical speeds conform to the requirements of 4.9.2 and 4.9.3.

6.3.4.3.5 Shop verification of the unbalanced response analysis shall be performed in accordance with 4.9.3.

- **6.3.4.3.6** If specified, tape recordings shall be made of all real-time vibration data as mutually agreed upon by the purchaser and the vendor.
- **6.3.4.3.7** If specified, the tape recordings of real-time vibration data shall be given to the purchaser.

6.3.4.4 Requirements — After mechanical running testing

- **6.3.4.4.1** Unless otherwise specified, all bearings shall be removed, inspected and reassembled after the test is completed. If specified, shaft end seals shall be removed for inspection following a successful running test.

6.3.4.4.2 Unless otherwise specified, if replacement or modification of bearings or seals, or dismantling of the case to replace or modify other parts is required to correct mechanical or performance deficiencies, the initial test shall not be accepted and the final shop tests shall be run after these replacements or corrections are made. A mechanical retest is not required if the compressor case must be dismantled simply to comply with the requirements of 6.3.5.

6.3.4.4.3 Unless otherwise specified, if minor scuffs and scratches occur on bearings or shaft end seal surfaces, minor cosmetic repairs of these parts is not a cause for rerunning the test. Shaft end seal contacts that result in a measurable change in dimension or metal transfer may be cause for rejection.

6.3.4.4.4 Unless otherwise specified, if spare rotors are ordered to permit concurrent manufacture, each spare rotor shall also be given a mechanical running test in accordance with the requirements of this International Standard.

6.3.4.4.5 Immediately upon completion of each witnessed mechanical or performance test, copies of the log data recorded during the test shall be given to the witnesses.

6.3.5 Assembled compressor gas leakage test

6.3.5.1 After the mechanical running test is completed, each completely assembled compressor casing intended for toxic, hazardous, flammable or hydrogen-rich service shall be tested as specified in 6.3.5.2 to 6.3.5.4 and subject to a soap-bubble test or other approved for gas leaks.

NOTE This test is intended to verify the integrity of the casing joint. It is recognized that certain shaft seals designs are not gas-tight during this test, and therefore a small leakage from seals could be acceptable.

6.3.5.2 Pressurize the casing (including end seals) to the maximum sealing pressure or the maximum seal design pressure, with an inert gas as agreed upon by the purchaser and the vendor. Hold at that pressure for a minimum period of 30 min.

NOTE Nitrogen is normally specified as the inert gas used, however in the case of low mole weight applications, a lighter gas such as helium could be specified.

- **6.3.5.3** If specified, pressurize the casing (with or without end seals installed) to the rated discharge pressure and hold at this pressure for a minimum period of 30 min. The test shall be considered satisfactory if no casing or casing joint leaks are observed.

6.3.5.4 The procedures of 6.3.5.2 and 6.3.5.3. may necessitate two separate tests.

6.3.5.5 Immediately upon completion of each witnessed mechanical or performance test, copies of the log data recorded during the test shall be given to the witnesses.

6.3.6 Optional tests

6.3.6.1 Shop tests — General

- The purchaser shall specify in the inquiry or in the order whether any of the following shop tests shall be performed. Test details shall be mutually agreed upon by the purchaser and the vendor.

6.3.6.2 Performance test

6.3.6.2.1 The compressor shall be performance-tested in accordance with ISO 5389 or ASME PTC 10 as mutually agreed between purchaser and vendor before ordering. A minimum of five points, including surge and overload, shall be taken at normal speed. For variable-speed machines, additional points may be specified.

Agreement should also be reached on the method of testing for multiple section compressors.

6.3.6.2.2 Head (specific compression work) and capacity shall have zero negative tolerance at the normal operating point (or other points as specified) and the power at this point shall not exceed 104 % of the specified value. Surge shall comply with the provisions of 4.1.4. This 104 % includes all tolerances.

6.3.6.2.3 For variable speed compressors, a speed other than the normal speed may be used if necessary to achieve the specified performance and performance tolerances, provided that this adjusted speed meets the criteria specified in 4.9.

6.3.6.2.4 For constant speed compressors, the capacity shall be as in 6.3.6.2.2. The head shall be within the range of 100 % to 105 % of the head at normal operating point. The power, based on measured head at normal inlet flow volume, shall not exceed 107 % of the value at the specified normal operating point, including the 4 % tolerance on power. If the power required at this point exceeds 107 %, excess head may be removed by trimming impellers or other means at the purchaser's option.

6.3.6.2.5 The performance test shall be conducted using only one rotor, unless otherwise specified.

6.3.6.2.6 Multicase compressor trains and compressors with intermediate process pressures shall have individual sectional head (pressure) tolerances as mutually agreed upon.

6.3.6.3 Complete unit test

Components such as compressors, gears, drivers and auxiliaries, which make up a complete unit, shall be tested together during the mechanical running test (see 6.3.4). A separate, auxiliary test may be performed with the purchaser's approval. If specified, torsional vibration measurements shall be made to verify the vendor's analysis. The complete unit test shall be performed in place of, or in addition to, separate tests of individual components specified by the purchaser.

6.3.6.4 Tandem test

Casings arranged for tandem drive shall be tested as a unit during the mechanical running test (see 6.3.4), using the shop driver and oil systems.

6.3.6.5 Gear test

The gear shall be tested with the machine unit during the mechanical running test (see 6.3.4).

6.3.6.6 Helium test

The compressor casing shall be tested for gas leakage with helium at the maximum allowable working pressure. The test shall be conducted with the casing submerged in water. The maximum allowable working pressure shall be maintained for a minimum of 30 min, with no bubbles permitted. As an alternative, a non-submerged soap bubble test may be performed if approved by the purchaser.

6.3.6.7 Sound level test

The sound level test shall be performed in accordance with ISO 3744 or ISO 9614.

6.3.6.8 Auxiliary equipment test

Auxiliary equipment such as oil systems, gears and control systems shall be tested in the vendor's shop. Details of the auxiliary equipment tests shall be developed jointly by the purchaser and the vendor.

6.3.6.9 Post-test inspection of casing internal

The compressor shall be dismantled, inspected, and reassembled after satisfactory completion of the mechanical running test. The purchaser shall specify whether the gas test required by 6.3.5 shall be performed before or after the post-test inspection.

NOTE The merits of post-test inspection of the casing internal need to be evaluated against the benefits of shipping a unit with proven mechanical assembly and casing joint integrity.

6.3.6.10 Full-pressure/full-load/full-speed test

The details of the full-pressure/full-load/full-speed test shall be developed jointly by the purchaser and vendor. This test may be substituted for the mechanical running test (see 6.3.4).

6.3.6.11 Post test inspection of the hydraulic coupling fit

After the running tests, the shrink fit of hydraulically mounted couplings shall be inspected by comparing hub/shaft match marks and ascertaining that the coupling hub has not moved on the shaft during the test.

6.3.6.12 Spare parts test

Spare parts, such as rotors, gears, diaphragms, bearings and seals, shall be tested as specified by the purchaser.

6.4 Preparation for shipment

- **6.4.1** Equipment shall be suitably prepared for the type of shipment specified, including blocking of the rotor if necessary. The preparation shall be mutually agreed upon and, unless otherwise specified, shall make the equipment suitable for six months of outdoor storage from the time of shipment, with no disassembly required before operation, except for inspection of bearings and seals. If storage for a longer period is contemplated, the purchaser shall consult with the vendor regarding the recommended procedures to be followed.
- 6.4.2** The vendor shall provide the purchaser with the instructions necessary to preserve the integrity of the storage preparation after the equipment arrives at the job site and before start-up.
- 6.4.3** The equipment shall be prepared for shipment after all testing and inspection has been completed and the equipment approved by the purchaser. The preparation shall include that specified as follows.
 - a) Exterior surfaces, except for machined surfaces, shall be given at least one coat of the manufacturer's standard finish paint. The paint shall not contain lead or chromates.
 - b) Exterior machined surfaces shall be coated with a suitable rust preventive.
 - c) The interior of the equipment shall be clean and free from scale, welding spatter and foreign objects. Any selection and application of preservatives or rust preventives shall be mutually agreed upon by the purchaser and the vendor.
 - d) Internal steel areas of bearing housings and carbon steel oil system auxiliary equipment such as reservoirs, vessels and piping shall be coated with a suitable oil-soluble rust preventive.
 - e) Flanged openings shall be provided with metal closures consisting of one or two plates with a combined thickness of at least 5 mm ($\frac{3}{16}$ "), with rubber gaskets and at least four full diameter bolts. For studed openings, studs should be shipped loose to avoid being damaged. If studs are installed for shipment, all nuts

needed for the intended service shall be used to secure closures. The arrangement of the closure is such that it is evident that the enclosure has been disturbed.

- f) Threaded openings shall be provided with steel caps or solid shank steel plugs. In no case shall non-metallic (e.g. plastic) plugs or caps be used.
- g) Openings that have been bevelled for welding shall be provided with closures designed to prevent entrance of foreign materials and damage to the bevel.
- h) Lifting points and lifting lugs shall be clearly identified on the equipment or equipment package. The recommended lifting arrangement shall be identified on boxed equipment.
- i) The equipment shall be identified with item and serial numbers. Material shipped separately shall be identified with securely affixed, corrosion-resistant metal tags indicating the item and serial number of the equipment for which it is intended. In addition, crated equipment shall be shipped with duplicate packing lists — one inside and one on the outside of the shipping container.
- j) If a spare rotor is purchased, the rotor shall be prepared for unheated indoor storage for a period of at least three years. The rotor shall be treated with a rust preventative and shall be housed in a vapour-barrier envelope with a slow-release, vapour-phase inhibitor. The rotor shall be suitably crated for shipment. Lead sheeting, at least 3 mm ($\frac{1}{8}$ " thick, or a purchaser-approved equivalent, shall be used between the rotor and the cradle at the support areas. The rotor shall not be supported at journals.
- k) If specified, the fit-up and assembly of machine mounted piping, intercoolers and so forth shall be completed in the vendor's shop prior to shipment.
- l) Exposed shafts and shaft couplings shall be protected against rust and damage.

6.4.4 Auxiliary piping connections furnished on the purchased equipment shall be impression-stamped or permanently tagged to agree with the vendor's connection table or general arrangement drawing.

6.4.5 Connections on auxiliary piping removed for shipment shall be match-marked clearly for reassembly.

7 Vendor data

7.1 General

7.1.1 The information to be furnished by the vendor is specified in 7.2 and 7.3 and further detailed in annex C.

7.1.2 The data shall be identified on transmittal (cover) letters and in title blocks or title pages with the following information (see 7.2.1, 7.3.1.1, 7.3.5 and 7.3.6.1):

- a) the purchaser/user's corporate name;
- b) the job/project number;
- c) the equipment item number and service name;
- d) the inquiry or purchase order number;
- e) any other identification specified in the inquiry or purchase order;
- f) the vendor's identifying proposal number, serial number, or other reference required to identify return correspondence completely.

7.1.3 A coordination meeting shall be held, preferably at the vendor's plant, within four to six weeks after the purchase commitment. Unless otherwise specified, the vendor shall prepare and distribute an agenda prior to this meeting, which, as a minimum, shall include review of the following items:

- a) the purchase order, scope of supply unit responsibility, and sub-vendor items;
- b) the data sheets;
- c) applicable specifications and previously agreed-upon exceptions;
- d) schedules for transmittal of data, production and testing;
- e) the quality assurance program and procedures;
- f) inspection, expediting and testing;
- g) schematics and bills of material for auxiliary systems;
- h) the physical orientation of the equipment piping and auxiliary systems;
- i) coupling selections;
- j) thrust-bearing sizing and estimated loadings;
- k) the rotor dynamics analysis;
- l) other technical items.

7.2 Proposals

7.2.1 General

The vendor shall forward the original proposal and the specified number of copies to the addresses given in the inquiry documents. The proposal shall include the data specified in 7.2.2 to 7.2.4, as well as a statement that the system and all its components are in strict accordance with this International Standard. If the system and components are not in accordance, the vendor shall include a list that details and explains each deviation. The vendor shall provide details to enable the purchaser to evaluate any proposed alternative designs. All correspondence shall be clearly identified in accordance with 7.1.2.

7.2.2 Drawings

7.2.2.1 As a minimum, the following drawings shall be furnished in the proposal.

- a) A general arrangement or outline drawing for each major skid or system, showing overall dimensions, maintenance clearance dimensions, overall weights, erection weights and maximum maintenance weights (indicated for each piece). The direction of rotation and the size and location of major purchaser connections shall also be indicated.
- b) Cross-sectional drawings showing the details of the proposed equipment.
- c) Schematics of all auxiliary systems, including the fuel, "lube" oil, seal oil or self-acting gas, and the control and electrical systems. Bills of material shall be included.
- d) Sketches that show methods for lifting the assembled machine or machines and major components. (This information may be included on the drawings specified in a).

7.2.2.2 If typical drawings, schematics and bills of material are used, they shall be marked up to show the correct weight and dimension data and to reflect the actual equipment and scope proposed.

7.2.3 Technical Data

The following data shall be included in the proposal.

- a) The purchaser's data sheets, with complete vendor's information entered thereon and literature to fully describe details of the offering.
- b) The purchaser's noise data sheet.
- c) The schedule according to which the vendor agrees to transmit all the data specified as part of the contract.
- d) A schedule for shipment of the equipment, in weeks after receipt of the order.
- e) A list of major wearing components, showing interchangeability with other units in the proposal.
- f) A list of recommended start-up spares, including any items that the vendor's experience indicates are likely to be required.
- g) A list of the special tools furnished for maintenance. The vendor shall identify any metric items included in the offering.
- h) A statement of any special protection required for start-up, operation and periods of idleness under the site conditions specified on the data sheets (see annex A). The list shall show the protection to be furnished by the purchaser, as well as that included in the vendor's scope of supply.
- i) A complete tabulation of utility requirements, such as those for steam, water, electricity, air gas, and "lube" oil, including the quantity of "lube" oil required and the supply pressure, the heat load to be removed by the oil, and the nameplate power rating and operating power requirements of auxiliary drivers. (Approximate data shall be defined and clearly identified as such).
- j) A description of the tests and inspection procedures for materials, as required by 4.11.1.4.
- k) A description of any special requirements specified in the purchaser's inquiry and as outlined in 4.10.3 and 4.11.1.2.
- l) A list of similar machines installed and operating under conditions analogous to those specified in the proposal.
- m) Any start-up, shutdown, or operating restrictions required to protect the integrity of the equipment.
- n) A summary of the materials of construction for the compressor, including hardness for materials exposed to H₂S (see 4.11.1.7) and a detailed description of the impeller (type of construction, materials and methods of attachment to the shaft).
- o) Indicated maximum seal-gas rates (injection or eduction) and rated or expected inner seal-oil leakage rates, or both, if applicable. The inner seal-oil leakage shall be given on the basis of volume per day per machine at design gas or oil differential pressures and normal compressor speed. If self-acting gas seals are supplied, expected seal gas consumption, minimum seal gas supply flow, and primary vent flow should be given at the maximum sealing pressure, and at the conditions over the operating envelope of the compressor.
- p) If interstage coolers are furnished by the vendor, data for the purchaser's heat and material balances and details of provisions for separating and withdrawing the condensate, including drawings that show cooling system details, and the vendor's recommendations regarding provision for support and piping expansion.
- q) Drawings, details and descriptions of the operation of instrumentation and controls, as well as the makes, materials and types of auxiliary equipment. The vendor shall also include a complete description of the alarm and shutdown facilities to be provided.
- r) A specific statement that the system and all its components are in strict accordance with this International Standard. If the system and components are not in strict accordance, the vendor shall include a specific list that details and explains each deviation.
- s) The minimum length of straight pipe required for proper flow characteristics at the inlet and at any side connection.

- t) Typical sound pressure levels for each item of equipment in the train covered by the proposal.
- u) A description of the buffer gas system for oil seals or barrier gas system for dry seals, if required.
- v) Maximum and minimum allowable seal pressures for each compressor.
- w) A statement of the manufacturer's capability regarding testing, including performance testing of the compressor and any other specified items on the train. Details of each optional test specified shall be included.

7.2.4 Curves

7.2.4.1 The vendor shall provide complete performance curves that fully define the envelope of operations and the point at which the manufacturer has illustrated the equipment. Performance curves shall be submitted for each section (between process nozzles) of each casing, in addition to an overall curve for the train. All curves shall be marked "predicted".

7.2.4.2 Curves for variable-speed compressors shall include the following.

- a) Discharge pressure, power, polytropic head and polytropic efficiency versus inlet capacity (from predicted surge point to 115 % rated capacity) at minimum operating speed and 80 %, 90 %, 100 % and 105 % speed, with an indication of the effect of specified inlet pressure, temperatures, and molar mass. Any specified operating points shall be noted within the envelope of the performance curve predicted.
- b) Steam flow of steam-turbine-driven units, first under the conditions specified in a), at normal steam conditions, and then at maximum horsepower under the most adverse steam conditions.
- c) Fuel flow for gas-turbine driven units, first under conditions specified in a), based upon normal fuel and site-ambient conditions, and then at maximum horsepower under the most adverse fuel and site-ambient conditions.

7.2.4.3 Curves and data for fixed speed compressors shall include the following.

- a) Discharge pressure, power, polytropic head and polytropic efficiency versus capacity (from surge point to 115 % rated capacity) at normal speed, indicating the effect of specified molar mass, suction pressures and temperatures. Alternative operating conditions requiring throttling shall be shown.
- b) Speed versus torque to overcome friction and windage for the compressor and gear unit, if any, for normal starting conditions (throttled suction) and also with specified suction conditions for emergency starting (open suction).
- c) Motor torque versus speed at rated voltage and at 80 % of rated voltage.
- d) Motor current versus speed at rated voltage and at 80 % of rated voltage.
- e) Moment of inertia of the compressor, gear, motor and coupling or couplings referred to motor speed.
- f) Estimated times for acceleration to rated speed for throttled suction and for open suction at 80 % of the nameplate motor voltage, unless otherwise specified.

7.2.5 Options

If specified, the vendor shall furnish a list of the procedures for any special or optional tests required by the purchaser or proposed by the vendor.

7.3 Contract data

7.3.1 General

7.3.1.1 The contract data to be furnished by the vendor is specified in annex C. Each drawing, bill of material and data sheet (see annex A) shall have a title block in its lower right-hand corner showing the date of certification, a reference to all identification data specified in 7.1.2, the revision number and date, and the title (see 7.3.2 and 7.3.3).

7.3.1.2 The purchaser shall promptly review the vendor's data after receiving them; however, this review shall not constitute permission to deviate from any requirements in the order unless specifically agreed upon in writing. After the data has been reviewed, the vendor shall furnish certified copies in the quantity specified.

7.3.1.3 A complete list of vendor data shall be included with the first issue of the major drawings. The list shall contain titles, drawing numbers and a schedule for transmission of all the data to be furnished by the vendor (see annex C).

7.3.2 Drawings

The drawings furnished shall contain sufficient information so that with the drawings and the manuals specified in 7.3.6, the purchaser can properly install, operate and maintain the ordered equipment. Drawings shall be clearly legible, and shall be identified in accordance with 7.3.1.1. As a minimum, the drawings shall include the details listed in annex C.

7.3.3 Technical data

7.3.3.1 General

The data shall be submitted in accordance with annex C and identified in accordance with 7.3.1.1. Any comments on the drawings or revisions of specifications that necessitate a change in the data shall be noted by the vendor. These notations shall result in the purchaser's issue of completed, corrected data sheets (see annex A) as part of the order specifications.

7.3.3.2 Curves

7.3.3.2.1 In accordance with the schedule set at the coordination meeting, the vendor shall provide complete performance curves encompassing the map of operations, with any limitations indicated. The curves shall comply with the requirements of 7.3.3.2.2 to 7.3.3.2.6.

7.3.3.2.2 The compressor serial number shall be shown on all curves.

7.3.3.2.3 All curves submitted prior to final performance testing (if required) shall be marked "predicted". Any set of curves resulting from a test shall be marked "tested".

7.3.3.2.4 If a performance test is specified, the vendor shall provide test data and curves when the test has been completed. The surge points shall be shown on the performance curves.

- **7.3.3.2.5** If specified, the vendor shall supply a nomograph (quadrant-type performance curve) for each compressor section. These curves typically shall show the influence of variation in speed, inlet volume, inlet pressure, inlet temperature and molecular mass or composition (or both) of the gas on discharge pressure, discharge temperature, gas power and efficiency. If a performance test is requested in the vendor's plant, the quadrant curves shall be based on the test results. The normal or rated point shall be plotted through each curve.

7.3.3.2.6 For compressors that have back-to-back impeller arrangements, the vendor shall furnish a curve showing the expected loading on the active or inactive side if the thrust bearing goes, versus any combination of the differential pressures across the low-pressure and high-pressure sections of the casing.

7.3.3.3 Data sheets (see annex A)

Completion of the data sheets is the joint responsibility of the purchaser and vendor. The purchaser is responsible for the process data on the datasheets. The vendor shall provide full information to enable completion of the data sheets for the train and auxiliary equipment, first for “as purchased”, and then for “as built”.

7.3.4 Progress reports

The vendor shall submit progress reports to the purchaser at the intervals specified. The reports shall include engineering, purchasing and manufacturing schedules for all major components. Planned and actual dates and the percentage completed shall be indicated for each “milestone” in the schedule.

7.3.5 Recommended parts

The vendor shall submit a complete list of spare parts, including those shown in the original proposal. The list shall include spare parts for all equipment and accessories supplied, with cross-sectional or assembly-type drawings for identification, part numbers and delivery times. Parts numbers shall identify each part for purposes of interchangeability. Standard purchased items shall be identified by the original manufacturer's numbers. The vendor shall forward the list to the purchaser promptly after receipt of the reviewed drawings and in time to permit order and delivery of the parts before field start-up. The transmittal letter shall be identified with the data specified in 7.1.2.

7.3.6 Installation, operation, maintenance and technical data manuals

7.3.6.1 General

The vendor shall provide sufficient written instructions, including a list of all drawings, to enable the purchaser to correctly install and maintain the complete equipment ordered. This information shall be compiled in a manual (or manuals), with a cover sheet containing all identifying data required in 7.1.2, and an index sheet containing section titles as well as a complete list of referenced and enclosed drawings by title and drawing number. The manual shall be prepared for the specified installation; the typical manual is not acceptable.

7.3.6.2 Installation manual

All special information required for proper installation design that is not on the drawings shall be compiled in a manual separate from the operating and maintenance instructions. This manual shall be forwarded at a time mutually agreed upon in the order, but no later than the final issue of prints. The manual shall contain information such as special alignment or grouting procedures, utility specifications (including quantities) and all installation design data, including the drawings and data specified in C.37.

7.3.6.3 Operating and maintenance manual

The manual containing operating and maintenance data shall be forwarded no more than thirty days after all specified tests have been successfully completed. This manual shall include a clause providing special instructions for operation at specified extreme environmental conditions (such as temperature). As a minimum, the manual shall also include all of the data listed in C.38.

7.3.6.4 Technical data manual

- If specified, the vendor shall provide the purchaser with a technical data manual within thirty days of completion of shop testing. (see C.44).

Annex A
(informative)

Typical data sheets

This annex comprises 12 centrifugal compressor data sheets for use with SI units, followed by the same data sheets for use with US customary units.

NOTE References between parentheses are to subclauses in this International Standard.

STANDARDSISO.COM : Click to view the full PDF of ISO 10439:2002

CENTRIFUGAL COMPRESSOR DATA SHEETS (SI units)

ENQUIRY/ORDER NO.		ITEM NO.					
JOB NO.							
REVISION	BY	DATE	CHKD	DATE	APP'D	DATE	

1 APPLICABLE TO: PROPOSAL PURCHASE DESIGN AS BUILT

2 FOR _____ UNIT _____

3 SITE _____ SERIAL No. _____

4 SERVICE _____ NO. REQUIRED _____

5 CONTINUOUS INTERMITTENT STANDBY DRIVER TYPE (5.1.1) _____

6 VENDOR _____ O MODEL _____ DRIVER ITEM NO. _____

7 NOTE: INFORMATION TO BE COMPLETED: BY PURCHASER BY VENDOR

8 **OPERATING CONDITIONS**

(ALL DATA PER PROCESS STAGE)	NORMAL	RATED	OTHER CONDITIONS (5.1.2)			
			A	B	C	D
GAS FLOW						
<input type="radio"/> GAS HANDLED (ALSO SEE PAGE 2)						
<input type="radio"/> VOLUME FLOW, AT 101,3 kPa & 0 °C, Z=1, DRY (m ³ /h)						
<input type="radio"/> MASS FLOW, [WET/DRY] (kg/h)						
INLET CONDITIONS (4.3.1)						
<input type="radio"/> PRESSURE (kPa)						
<input type="radio"/> TEMPERATURE (°C)						
<input type="radio"/> RELATIVE HUMIDTY (%)						
<input type="radio"/> MOLECULAR MASS (mw)						
<input type="radio"/> ISENTROPIC EXPONENT CP/ CV (K ₁)						
<input type="checkbox"/> COMPRESSIBILITY (Z ₁)						
<input type="checkbox"/> INLET VOLUME FLOW, [WET/DRY] (m ³ /h)						
DISCHARGE CONDITIONS (4.3.1)						
<input type="checkbox"/> PRESSURE (kPa)						
<input type="checkbox"/> TEMPERATURE (°C)						
<input type="checkbox"/> ISENTROPIC EXPONENT (K ₂)						
<input type="checkbox"/> COMPRESSIBILITY (Z ₂)						
PERFORMANCE(4.1.4)(4.1.5)						
<input type="checkbox"/> POLYTROPIC HEAD, SPECIFIC COMPRESSION WORK FLANGE TO FLANGE (kJ/kg)						
<input type="checkbox"/> POLYTROPIC EFFICIENCY FLANGE TO FLANGE (%)						
<input type="checkbox"/> COMPRESSOR MECHANICAL LOSSES (kW)						
<input type="checkbox"/> COMPRESSOR ABSORBED POWER (kW)						
<input type="checkbox"/> COMPRESSOR POWER REQUIRED, AT DRIVER COUPLING (kW)						
<input type="checkbox"/> SPEED (r/min)						
<input type="radio"/> ESTIMATED SURGE AT ABOVE SPEED (m ³ /h)						
<input type="checkbox"/> GUARANTEE POINT FLANGE TO FLANGE						
<input type="checkbox"/> PERFORMANCE CURVE NUMBER						
PROCESS CONTROL						
METHOD <input type="radio"/> SUCTION THROTTLING <input type="radio"/> VARIABLE <input type="radio"/> SPEED VARIATION <input type="radio"/> DISCHARGE <input type="radio"/> COOLED BYPASS						
FROM _____ (kPa) GUIDE VANES FROM _____% BLOWOFF FROM _____						
TO _____ (kPa) (5.4.2.4) TO _____% TO _____ TO _____						
SIGNAL <input type="radio"/> SOURCE (5.4.2.1) _____						
TYPE <input type="radio"/> ELECTRONIC <input type="radio"/> PNEUMATIC <input type="radio"/> OTHER _____ <input type="radio"/> RANGE _____ (mA) _____ (kPa)						
ANTI-SURGE SYSTEM (5.4.2.2)						
ANTI-SURGE BYPASS <input type="radio"/> MANUAL <input type="radio"/> AUTOMATIC <input type="radio"/> NONE						
A.-S. VALVE SIZING BY: _____ Vendor _____ OTHERS, A.-S. VALVE SUPPLIED BY: _____ Vendor _____ Purchaser						
A.-S. CONTROLLER SUPPLIED BY: _____ Vendor _____ Purchaser						
FLOW/PRESSURE SENSING ELEMENTS SUPPLIED BY: _____ Vendor _____ Purchaser						
FLOW/PRESSURE SENSING ELEMENT POSITIONS: <input type="radio"/> INLET <input type="radio"/> DISCHARGE						
LOAD SHARE CONTROLLER SUPPLIED BY: _____ Vendor _____ Purchaser						

CENTRIFUGAL COMPRESSOR DATA SHEETS (SI units)

ENQUIRY/ORDER NO.				ITEM NO.			
JOB NO.							
REVISION	BY	DATE	CH'KD	DATE	APP'D	DATE	

1	OPERATING CONDITIONS (Continued) (5.1.2) (4.11.1.8)							
2	GAS ANALYSIS:	NORMAL	RATED	OTHER CONDITIONS				REMARKS: (4.11.1.3) (4.11.1.8)
3	O MOL% O			A	B	C	D	
4								
5		M kg/kmol						
6	AIR	28,966						
7	OXYGEN	32,000						
8	NITROGEN	28,016						
9	WATER VAPOUR	18,016						
10	CARBON MONOXIDE	28,010						
11	CARBON DIOXIDE	44,010						
12	HYDROGEN SULPHIDE	34,076					(4.11.1.7)	
13	HYDROGEN	2,016						
14	METHANE	16,042						
15	ETHYLENE	28,052						
16	ETHANE	30,068						
17	PROPYLENE	42,078						
18	PROPANE	44,094						
19	I-BUTANE	58,120						
20	N-BUTANE	58,120						
21	I-PENTANE	72,146						
22	N-PENTANE	72,146						
23	HEXANE PLUS							
24								
25	TOTAL							
26	AVG. MOL. MASS							
27	REMARKS:							
28								
29								
30								
31								
32								
33								
34								
35								
36								
37								
38								
39								
40								
41								
42								
43								
44								
45								
46								
47								
48								
49								
50								

STANDARDSISO.COM : Click to view the full PDF of ISO 10439:2002

CENTRIFUGAL COMPRESSOR DATA SHEETS (SI units)

ENQUIRY/ORDER NO.		ITEM NO.				
JOB NO.						
REVISION	BY	DATE	CHKD	DATE	APPD	DATE

CONSTRUCTION FEATURES

SPEEDS:
 MAX. CONT. _____ r/min TRIP _____ r/min
 MAX. TIP SPEEDS: _____ m/s @ RATED SPEED
 _____ m/s @ MAX. CONT. SPEED

LATERAL CRITICAL SPEEDS (DAMPED)
 FIRST CRITICAL _____ r/min _____ MODE
 SECOND CRITICAL _____ r/min _____ MODE
 THIRD CRITICAL _____ r/min _____ MODE
 FOURTH CRITICAL _____ r/min _____ MODE

TRAIN LATERAL ANALYSIS REQUIRED (4.9.2.3)
 UNDAMPED STIFFNESS MAP REQUIRED (4.9.2.4)
 TRAIN TORSIONAL ANALYSIS REQUIRED (TUBINE DRIVEN TRAIN (4.9.4.6)

TORSIONAL CRITICAL SPEEDS:
 FIRST CRITICAL _____ r/min
 SECOND CRITICAL _____ r/min
 THIRD CRITICAL _____ r/min
 FOURTH CRITICAL _____ r/min

VIBRATION:
 ALLOWABLE TEST LEVEL _____ µm
 (PEAK TO PEAK)

ROTATION, VIEWED FROM DRIVEN END [CW/CCW]
 MATERIALS INSPECTION REQUIREMENTS (6.2.2)
 SPECIAL CHARPY TESTING (4.11.3)
 RADIOGRAPHY REQUIRED FOR _____
 MAGNETIC PARTICLE REQUIRED FOR _____
 LIQUID PENETRANT REQUIRED FOR _____

CASING:
 MODEL _____
 CASING SPLIT _____
 Pressure design code (4.1.20) _____
 MATERIAL _____
 THICKNESS (mm) _____ CORR. ALLOW. (mm) _____
 MAX WORKING PRESS _____ kPa
 MAX DESIGN PRESS _____ kPa
 TEST PRESS (kPa): _____ HELIUM _____ HYDRO _____
 MAX. OPER. TEMP. _____ °C MIN. OPER. TEMP. _____ °C
 MAX. NO. OF IMPELLERS FOR CASING _____
 MAX. CASING CAPACITY VOLUME FLOW (m³/h) _____
 RADIOGRAPH QUALITY YES NO
 CASING SPLIT SEALING _____
 SYSTEM RELIEF VALVE SET PT. (4.2.4) _____ kPa

DIAPHRAGMS:
 MATERIAL _____

IMPELLERS:
 NO. _____ DIAMETERS (mm) _____
 NO. VANES EACH IMPELLER _____

TYPE (OPEN, ENCLOSED, ETC.) _____
 TYPE FABRICATION _____
 MATERIAL _____
 MAX. YIELD STRENGTH (MPa) _____
 HARDNESS [HB/HRC] MAX _____ MIN _____
 SMALLEST TIP INTERNAL WIDTH (mm) _____
 MAX. MACH. NO. @ IMPELLER EYE _____
 MAX. IMPELLER HEAD @ RATED SPEED (kJ/kg) _____

SHAFT:
 MATERIAL _____
 DIA @ IMPELLERS (mm) _____ DIA @ COUPLING (mm) _____
 SHAFT END: _____ TAPERED _____ CYLINDRICAL
 MAX. YIELD STRENGTH (MPa) _____
 HARDNESS [HB/HRC] _____
 STRESS AT COUPLING (MPa) _____

BALANCE PISTON:
 MATERIAL _____ AREA _____ mm²
 FIXATION METHOD _____

SHAFT SLEEVES (4.8.1.2):
 AT INTERSTG. CLOSE CLEARANCE POINTS MATL _____
 AT SHAFT SEALS _____ MATL _____

LABYRINTHS:
 INTERSTAGE
 TYPE _____ MATERIAL _____
 BALANCE PISTON
 TYPE _____ MATERIAL _____

SHAFT SEALS: GAS SEALS use pages 10 to 12
 SEAL TYPE (4.8.1.3) _____
 SETTLING OUT PRESSURE (kPa) _____
 SPECIAL OPERATION (4.8.1.1) _____
 SUPPLEMENTAL DEVICE REQUIRED FOR CONTACT SEALS (4.8.2.2) TYPE _____
 BUFFER GAS SYSTEM REQUIRED (4.8.2.4) (SEE ALSO PAGE 10)
 TYPE BUFFER GAS _____
 BUFFER GAS CONTROL SYSTEM SCHEMATIC BY VENDOR
 PRESSURIZING GAS FOR SUBATMOSPHERIC SEALS (4.8.2.5)
 TYPE SEAL _____
 INNER LEAKAGE GUAR. (litre/DAY/SEAL) _____

BUFFER GAS REQUIRED FOR:
 AIR RUN-IN OTHER _____

BUFFER GAS FLOW (PER SEAL):
 NORM: _____ kg/h @ _____ kPa (g) ΔP _____
 MAX: _____ kg/h @ _____ kPa (g) ΔP _____

LUBE/SEAL OIL SYSTEM SEPARATE _____ COMBINED _____ (4.10.3)

BEARING HOUSING CONSTRUCTION:
 TYPE (SEPARATE, INTEGRAL) _____ SPLIT _____
 MATERIAL _____

CENTRIFUGAL COMPRESSOR DATA SHEETS (SI units)

ENQUIRY/ORDER NO. _____						
JOB NO. _____				ITEM NO. _____		
REVISION	BY	DATE	CH'KD	DATE	APP'D	DATE

1 CONSTRUCTION FEATURES (CONTINUED)

2 BEARINGS AND BEARING HOUSINGS

3	RADIAL	DRIVE END	NON-DRIVE END	THRUST	ACTIVE	INACTIVE
4	<input type="checkbox"/> TYPE			<input type="checkbox"/> TYPE		
5	<input type="checkbox"/> MANUFACTURER			<input type="checkbox"/> MANUFACTURER		
6	<input type="checkbox"/> LENGTH (mm)			<input type="checkbox"/> UNIT LOADING (MAX) (kPa)		
7	<input type="checkbox"/> SHAFT DIA (mm)			<input type="checkbox"/> UNIT LOADING (ULT) (kPa)		
8	<input type="checkbox"/> Unit load (Act/allow) (kPa)			<input type="checkbox"/> AREA (mm ²)		
9	<input type="checkbox"/> BASE MATERIAL			<input type="checkbox"/> NO. PADS		
10	<input type="checkbox"/> BABBIT THICKNESS (mm)			<input type="checkbox"/> PIVOT: CTR/OFFSET (%)		
11	<input type="checkbox"/> NO. PADS			<input type="checkbox"/> PAD BASE MATERIAL		
12	<input type="checkbox"/> LOAD: BETWEEN/ON PAD			<input type="checkbox"/>		
13	<input type="checkbox"/> PIVOT: CTR/OFFSET (%)			LUBRICATION: <input type="radio"/> FLOODED <input type="radio"/> DIRECTED		
14	<input type="checkbox"/> BEARING SPAN (mm)			THRUST COLLAR: <input type="radio"/> INTEGRAL <input type="radio"/> REPLACEABLE		
15	<input type="checkbox"/> SQUEEZE FILM DAMPING			MATERIAL _____		
16	<input type="checkbox"/>					

- 17 BEARING TEMPERATURE DEVICES
- SEE ATTACHED API 670 DATA SHEET
 - 18 THERMISTORS
 - 19 TYPE _____ POS. TEMP COEFF _____ NEG. TEMP COEFF _____
 - 20 TEMP SWITCH & INDICATOR BY: _____ PURCH _____ MFR _____
 - 21 THERMOCOUPLES
 - 22 SELECTOR SWITCH & INDICATOR BY: _____ PURCH _____ MFR _____
 - 23 RESISTANCE TEMP DETECTORS
 - 24 RESISTANCE MATL. _____ OHM _____
 - 25 SELECT SWITCH & INDICATOR BY: _____ PURCH _____ MFR _____
 - 26 LOCATION-JOURNAL BRG
 - 27 NO. _____ EA. PAD _____ EVERY OTHER PAD _____ PER BRG _____
 - OTHER _____
 - 28 LOCATION-THRUST BRG
 - 29 NO. _____ EA. PAD _____ EVERY OTHER PAD _____ PER BRG _____
 - OTHER _____
 - 30 NO. (INACT) _____ EA. PAD _____ EVERY OTHER PAD _____ PER BRG _____
 - OTHER _____
 - 31 MONITOR SUPPLIED BY (5.4.7.3) _____
 - 32 LOCATION _____ ENCLOSURE _____
 - 33 MFR _____ MODEL _____
 - 34 SCALE _____ ALARM SET @ _____ °C
 - 35 SHTDWN SET @ _____ °C TIME DELAY _____ s

- VIBRATION DETECTORS:
- SEE ATTACHED API 670 DATA SHEET
 - TYPE _____ MODEL _____
 - MFR _____
 - NO. AT EA SHAFT BEARING _____ TOTAL NO. _____
 - OSCILLATOR-DETECTORS SUPPLIED BY _____
 - MFR _____ MODEL _____
 - MONITOR SUPPLIED BY (5.4.7.2) _____
 - LOCATION _____ ENCLOSURE _____
 - MFR _____ MODEL _____
 - SCALE _____ ALARM SET @ _____ μm
 - SHTDWN: SET @ _____ μm TIME DELAY _____ s

- AXIAL POSITION DETECTOR:
- SEE ATTACHED API 670 DATA SHEET
 - TYPE _____ MODEL _____
 - MFR _____ NO. REQUIRED _____
 - OSCILLATOR-DEMODULATOR SUPPLIED BY: _____
 - MFR _____ MODEL _____
 - MONITOR SUPPLIED BY (5.4.7.2) _____
 - LOCATION _____ ENCLOSURE _____
 - MFR _____ MODEL _____
 - SCALE _____ ALARM SET @ _____ mm
 - SHTDWN SET @ _____ mm TIME DELAY _____ s

36 CONNECTIONS

37	COMPRESSOR CASING	<input type="radio"/> DESIGN APPROVAL REQUIRED (4.11.2.12)	<input type="checkbox"/> SIZE	<input type="checkbox"/> RATING/FACING	<input type="radio"/> POSITION (4.4.2.1)	<input type="radio"/> FLANGED STUDDED (4.4.2.1)	OR	<input type="radio"/> MATING FLG & GASKET BY VENDOR (4.4.2.2)	GAS VELOCITY m/s
38	INLET								
39	DISCHARGE								
40									
41									
42									
43									
44									
45									
46									
47									
48									
49									
50									

CENTRIFUGAL COMPRESSOR DATA SHEETS (SI units)

ENQUIRY/ORDER NO.		ITEM NO.					
JOB NO.							
REVISION	BY	DATE	CH'KD	DATE	APP'D	DATE	

1	<input type="checkbox"/> OTHER CONNECTIONS [DIRECT/SKID EDGE]			<input type="checkbox"/> ALLOWABLE PIPING FORCES AND MOMENTS:							
3	SERVICE:			CONNECTION		INLET		DISCHARGE			
4		NO	SIZE	TYPE		FORCE N	MOMT Nm	FORCE N	MOMT Nm	FORCEN	MOMT Nm
5	LUBE -OIL INLET				AXIAL						
6	LUBE-OIL OUTLET				VERTICAL						
7	SEAL-OIL INLET				HORIZ. 90°						
8	SEAL-OIL OUTLET				CONNECTION						
9	CASING DRAINS				AXIAL						
10	STAGE DRAINS				VERTICAL						
11	VENTS				HORIZ. 90°						
12	COOLING WATER										
13	PRESSURE										
14	TEMPERATURE										
15	PURGE FOR:				<input type="radio"/> VIBRATION TRANSDUCER [CASING/BEARING HOUSING] (5.4.7.4) <input type="radio"/> SEE ATTACHED API 670 DATA SHEET <input type="radio"/> TYPE _____ <input type="checkbox"/> MODEL _____ <input type="radio"/> MFR _____ NO. REQUIRED _____ <input type="radio"/> LOCATION _____ <input type="radio"/> OSCILATOR-DEMOMULATORS SUPPLIED BY _____ <input type="radio"/> MFR _____ <input type="checkbox"/> MODEL _____ <input type="radio"/> MONITOR SUPPLIED BY (5.4.7.5) _____ <input type="radio"/> LOCATION _____ ENCLOSURE _____ <input type="radio"/> MFR _____ <input type="checkbox"/> MODEL _____ <input type="checkbox"/> SCALE RANGE _____ <input type="radio"/> ALARM: <input type="checkbox"/> SET @ _____ mm/s ² <input type="radio"/> SHTDWN <input type="checkbox"/> SET @ _____ mm/s ² <input type="radio"/> TIME DELAY _____ s						
16	BRG. HOUSING				<input type="radio"/> INDIVIDUAL STAGE DRAINS REQUIRED (4.4.3.2) <input type="radio"/> VALVED & BLINDED <input type="radio"/> VALVED & BLINDED & MANIFOLD <input type="radio"/> VALVE ACTUATION <input type="radio"/> MANUAL <input type="radio"/> AUTO <input type="radio"/> _____						
17	BTWN BRG & SEAL										
18	BTWN SEAL & GAS										
19	SOLVENT INJECTION										
20											
21	ACCESSORIES										
22	COUPLINGS AND GUARDS (5.2.2)										
23	<input type="radio"/> SEE ATTACHED ISO 14691 DATA SHEET FOR FULL DETAILS ON ROTATING ELEMENTS AND SHAFT ENDS										
24	COUPLING FURNISHED BY _____										
25	MANUFACTURER _____ TYPE _____ MODEL _____										
26	COUPLING GUARD FURNISHED BY: _____										
27	TYPE: <input type="radio"/> FULLY ENCLOSED <input type="radio"/> SEMI-OPEN <input type="radio"/> OTHER										
28	MATERIAL: _____										
29	COUPLING DETAILS										
30	<input type="checkbox"/> SHAFT MOUNTING _____										
31	<input type="checkbox"/> HUB MASS _____ kg										
32	<input type="checkbox"/> SPACER LENGTH _____ mm										
33	<input type="checkbox"/> SPACER MASS _____ kg										
34	<input type="radio"/> VENDOR MOUNT HALF COUPLING <input type="radio"/> IDLING ADAPTER/SOLO PLATE REQUIRED (5.2.4) LUBRICATING REQUIREMENTS: <input type="radio"/> NON-LUBE <input type="radio"/> GREASE <input type="radio"/> CONT. OIL LUBE <input type="radio"/> OTHER QUANTITY PER HUB _____ m ³ /h <input type="radio"/> PLUG AND RING GAUGES REQUIRED (5.2.5)										
35	MOUNTING PLATES										
36	<input type="radio"/> BASEPLATES: FURNISHED BY (5.3.1.1) _____										
37	<input type="radio"/> COMPRESSOR ONLY (5.3.2.8) <input type="radio"/> DRIVER <input type="radio"/> GEAR										
38	<input type="radio"/> OTHER _____										
39	<input type="radio"/> DRIP TRIM <input type="radio"/> LEVELLING PADS (5.3.2.2.)										
40	<input type="radio"/> COLUMN MOUNTING (5.3.2.3)										
41	<input type="radio"/> SUB-SOLE PLATES REQUIRED (5.3.2.5)										
42	<input type="radio"/> STAINLESS STEEL SHIM THICKNESS _____ mm										
43	<input type="radio"/> PRIMER FOR EPOXY GROUT REQUIRED (5.3.1.2)										
44	TYPE _____										
45	<input type="radio"/> LIMIT OF PIPING (5.5.1.3)										
46	<input type="radio"/> SOLEPLATES: FURNISHED BY: _____										
47	<input type="checkbox"/> THICKNESS _____ mm										
48	<input type="radio"/> SUBSOLE PLATES REQUIRED (5.3.3.2)										
49	<input type="radio"/> LEVELLING BLOCKS REQUIRED										
50	<input type="radio"/> STAINLESS STEEL SHIM										
	<input type="checkbox"/> THICKNESS _____ mm										
	<input type="radio"/> DRIVER <input type="radio"/> GEAR <input type="radio"/> COMPRESSOR										
	<input type="radio"/> PRIMER FOR EPOXY GROUT REQUIRED (5.3.1.2)										
	TYPE _____										

CENTRIFUGAL COMPRESSOR DATA SHEETS (SI units)

ENQUIRY/ORDER NO.				ITEM NO.			
JOB NO.							
REVISION	BY	DATE	CH'KD	DATE	APP'D	DATE	

1 LOCATION, SITE DATA, UTILITIES AND MASS & SPACE REQUIREMENTS

2 LOCATION: COMPRESSOR SKID

3 INDOOR HEATED UNDER ROOF

4 OUTDOOR UNHEATED PARTIAL SIDES

5 GRADE MEZZANINE _____

6 WINTERIZATION REQD. (4.1.10) TROPICALISATION REQD. (5.4.6.6)

7 SITE DATA:

8 ELEVATION _____ m BAROMETER _____ kPa

9 RANGE OF AMBIENT TEMPS:

	°C	RELATIVE HUMIDITY
11 SITE RATED	_____	_____
12 NORMAL	_____	_____
13 MAXIMUM	_____	_____
14 MINIMUM	_____	_____

TOTAL UTILITY CONSUMPTION:

COOLING WATER _____ m³/h

STEAM, NORMAL _____ kg/h

STEAM, MAX _____ kg/h

INSTRUMENT AIR _____ kg/h

POWER (DRIVER) _____ kW

POWER (AUXILIARIES) _____ kW

POWER (HEATERS) _____ kW

PURGE (AIR/N₂) _____ kg/h

15 LOCATION: AUXILIARY EQUIPMENT

16 CONTROL PANEL _____

17 LUBE/SEAL OIL CONSOLE _____

18 NITROGEN GENERATOR _____

19 _____

20 UNUSUAL CONDITIONS: DUST FUMES

21 OTHER (4.11.1.8) _____

MASSES (kg):

COMPR. _____ GEAR _____ DRIVER _____ BASE _____

ROTORS: COMPR. _____ DRIVER _____ GEAR _____

COMPR UPPER CASE/CARTRIDGE _____

SOUR SEAL OIL TRAPS _____

LUBE OIL CONSOLE (WET/DRY) _____

SEAL OIL CONSOLE (WET/DRY) _____

OVERHEAD BRG RUNDOWN TANK (WET/ DRY) _____

NITROGEN GENERATOR PACKAGE _____

CONTROL PANEL _____

MAX. FOR MAINTENANCE (IDENTIFY) _____

TOTALS FOR SHIPPING _____

23 AREA CLASSIFICATION (4.1.16)

	ZONE	GAS GROUP	TEMP CLASS
24 COMPRESSOR SKID	_____	_____	_____
25 LUBE/SEAL OIL CONSOLE	_____	_____	_____
26 CONTROL PANEL	_____	_____	_____
27 NITROGEN GENERATOR	_____	_____	_____
28 _____	_____	_____	_____
29 _____	_____	_____	_____

30 UTILITY CONDITIONS:

STEAM:		DRIVERS		HEATING	
32 INLET MIN	_____ kPa	_____ °C	_____ kPa	_____ °C	_____ °C
33 NORM	_____ kPa	_____ °C	_____ kPa	_____ °C	_____ °C
34 MAX	_____ kPa	_____ °C	_____ kPa	_____ °C	_____ °C
35 EXHAUST. MIN	_____ kPa	_____ °C	_____ kPa	_____ °C	_____ °C
36 NORM	_____ kPa	_____ °C	_____ kPa	_____ °C	_____ °C
37 MAX	_____ kPa	_____ °C	_____ kPa	_____ °C	_____ °C

SPACE REQUIREMENTS (m):

COMPLETE UNIT: L _____ W _____ H _____

LUBE OIL CONSOLE: L _____ W _____ H _____

SEAL OIL CONSOLE: L _____ W _____ H _____

O'HD S.O. TANK L _____ W _____ H _____

O'HD BRG. R.D. TANK L _____ W _____ H _____

N₂ GEN PACKAGE L _____ W _____ H _____

CONTROL PANEL L _____ W _____ H _____

38 ELECTRICAL SUPPLY (5.4.6.1)

	DRIVERS	HEATING	CONTROL	SHUTDOWN
39 VOLTAGE	_____	_____	_____	_____
40 HERTZ	_____	_____	_____	_____
41 PHASE	_____	_____	_____	_____

43 COOLING WATER:

44 TEMP. INLET _____ °C MAX RETURN _____ °C

45 PRESS NORM _____ kPa DESIGN _____ kPa

46 MIN RETURN _____ kPa MAX ALLOW ΔP _____ kPa

47 WATER SOURCE _____

48 INSTRUMENT AIR:

49 MAX PRESS _____ kPa MIN PRESS _____ kPa

50 NITROGEN:

MAX PRESS _____ kPa MIN PRESS _____ kPa

REMARKS:

CENTRIFUGAL COMPRESSOR DATA SHEETS (SI units)

ENQUIRY/ORDER NO.		ITEM NO.				
JOB NO.						
REVISION	BY	DATE	CH'KD	DATE	APP'D	DATE

INSPECTION AND TEST				SPECIFICATIONS AND MISCELLANEOUS		
1	<input type="checkbox"/> SHOP INSPECTION AND TESTS: (6.1.4) (6.2.1.3)			NOISE SPECIFICATIONS: (4.1.11)		
2		<u>REQ'D</u>	<u>WITNS'D</u>	<u>OBSV'D</u>	<input type="checkbox"/> APPLICABLE TO MACHINE:	
3					SEE SPECIFICATION _____	
4	SHOP INSPECTION	<input type="radio"/>			<input type="checkbox"/> APPLICABLE TO NEIGHBOURHOOD:	
5	CLEANLINESS (6.2.1.5)	<input type="radio"/>			SEE SPECIFICATION _____	
6	HYDROSTATIC	<input checked="" type="radio"/>	<input type="radio"/>	<input type="radio"/>	ACOUSTIC HOUSING: <input type="radio"/> YES <input type="radio"/> NO	
7	IMPELLER OVERSPEED	<input checked="" type="radio"/>	<input type="radio"/>	<input type="radio"/>	APPLICABLE REGULATIONS: (4.1.21)	
8	MECHANICAL RUN	<input checked="" type="radio"/>	<input type="radio"/>	<input type="radio"/>	_____	
9	<input type="checkbox"/> CONTRACT COUPLING				PAINTING:	
10	<input type="checkbox"/> CONTRACT PROBES				<input type="checkbox"/> MANUFACTURER'S STD.	
11	<input type="checkbox"/> IDLING ADAPTOR(S)				<input type="checkbox"/> OTHER _____	
12	<input type="checkbox"/> SHOP PROBES				SHIPMENT: (6.4.1)	
13	VARY LUBE & SEAL OIL PRESSURES AND TEMPERATURES (6.3.4.2.5)	<input type="radio"/>			<input type="checkbox"/> DOMESTIC <input type="checkbox"/> EXPORT <input type="checkbox"/> EXPORT BOXING REQD.	
14	POLAR FORM VIB DATA (6.3.4.3.3)	<input type="radio"/>			<input type="checkbox"/> OUTDOOR STORAGE MORE THAN 6 MONTHS (6.4.1)	
15	TAPE RECORD VIB (6.3.4.3.6)	<input type="radio"/>			SPARE ROTOR ASSEMBLY PACKAGED FOR (6.4.3)	
16	TAPE DATA TO PURCHASER (6.3.4.3.7)	<input type="radio"/>			<input type="checkbox"/> HORIZONTAL STORAGE <input type="checkbox"/> VERTICAL STORAGE	
17	RESIDUAL UNBALANCE CHECK (4.9.3.1)	<input type="radio"/>	<input type="radio"/>	<input type="radio"/>	MISCELLANEOUS:	
18	SHAFT END SEAL INSP. (6.3.4.4.1)	<input type="radio"/>			<input type="checkbox"/> RECOMMENDED STRAIGHT RUN OF PIPE DIAMETERS	
19	GAS LEAK TEST DISCH. PRESS (6.3.5.2) (6.3.5.3)	<input type="radio"/>	<input type="radio"/>	<input type="radio"/>	BEFORE SUCTION _____	
20	<input type="radio"/> BEFORE <input type="radio"/> AFTER MECH RUN				<input type="checkbox"/> VENDOR'S REVIEW & COMMENTS ON PURCHASER'S PIPING & FOUNDATION (4.1.15) (5.3.2)	
21	PERFORMANCE TEST [GAS/AIR] (6.3.6.2)	<input type="radio"/>	<input type="radio"/>	<input type="radio"/>	<input type="checkbox"/> COMPRESSOR TO BE SUITABLE FOR FIELD RUN IN ON AIR (4.1.18)	
22	<input type="radio"/> ISO 5389 <input type="radio"/> PTC 10				<input type="checkbox"/> PROVISION FOR LIQUID INJECTION (4.1.12) _____	
23	SINGLE POINT TEST	<input type="radio"/>	<input type="radio"/>	<input type="radio"/>	<input type="checkbox"/> VENDOR'S REVIEW & COMMENTS ON PURCHASER'S CONTROL SYSTEMS (5.4.1.1)	
24	_____ POINTS TEST	<input type="radio"/>	<input type="radio"/>	<input type="radio"/>	<input type="checkbox"/> EXTENT OF PROCESS PIPING BY VENDOR (5.5.3.1) _____	
25	_____ SPEED LINES	<input type="radio"/>	<input type="radio"/>	<input type="radio"/>	<input type="checkbox"/> SHOP FITUP OF VENDOR PROCESS PIPING (6.4.3)	
26	_____	<input type="radio"/>	<input type="radio"/>	<input type="radio"/>	<input type="checkbox"/> WELDING HARDNESS TESTING (6.2.1.6)	
27	COMP. WITH SHOP DRIVER	<input type="radio"/>	<input type="radio"/>	<input type="radio"/>	<input type="checkbox"/> INSPECTION CHECKLIST REQUIRED (6.1.6)	
28	COMP. WITH JOB DRIVER	<input type="radio"/>	<input type="radio"/>	<input type="radio"/>	<input type="checkbox"/> TECHNICAL DATA MANUAL REQUIRED (7.3.6.4)	
29	USE SHOP LUBE/SEAL OIL SYSTEM	<input type="radio"/>	<input type="radio"/>	<input type="radio"/>	_____	
30	USE JOB LUBE/SEAL OIL SYSTEM	<input type="radio"/>	<input type="radio"/>	<input type="radio"/>	_____	
31	CHECK BRG'S AND SEALS AFTER TEST	<input type="radio"/>	<input type="radio"/>	<input type="radio"/>	_____	
32	NITROGEN GENERATOR PACKAGE TEST	<input type="radio"/>	<input type="radio"/>	<input type="radio"/>	_____	
33	DRY GAS SEAL SYSTEM TEST	<input type="radio"/>	<input type="radio"/>	<input type="radio"/>	_____	
34	DRY GAS SEAL TESTING AT SEAL VDR	<input type="radio"/>	<input type="radio"/>	<input type="radio"/>	_____	
35	CONTROL PANEL FUNCTIONAL TEST	<input type="radio"/>	<input type="radio"/>	<input type="radio"/>	_____	
36	MECHANICAL RUN USING SPARE ELEMENTS	<input type="radio"/>	<input type="radio"/>	<input type="radio"/>	_____	
37	COMPLETE UNIT TEST (6.3.6.3)	<input type="radio"/>	<input type="radio"/>	<input type="radio"/>	_____	
38	TORSIONAL VIB MEAS	<input type="radio"/>	<input type="radio"/>	<input type="radio"/>	_____	
39	TANDEM TEST (6.3.6.4)	<input type="radio"/>	<input type="radio"/>	<input type="radio"/>	_____	
40	GEAR TEST (6.3.6.5)	<input type="radio"/>	<input type="radio"/>	<input type="radio"/>	_____	
41	HELIUM LEAK TEST (6.3.6.6)	<input type="radio"/>	<input type="radio"/>	<input type="radio"/>	_____	
42	SOUND LEVEL TEST (6.3.6.7)	<input type="radio"/>	<input type="radio"/>	<input type="radio"/>	_____	
43	FULL LOAD/SPEED/PRESS TEST (6.3.6.10)	<input type="radio"/>	<input type="radio"/>	<input type="radio"/>	_____	
44	HYDRAULIC COUPLING INSP (6.3.6.11)	<input type="radio"/>	<input type="radio"/>	<input type="radio"/>	_____	
45	CERTIFIED COPIES OF TEST DATA	<input type="radio"/>	<input type="radio"/>	<input type="radio"/>	_____	
46	_____	<input type="radio"/>	<input type="radio"/>	<input type="radio"/>	_____	
47	_____	<input type="radio"/>	<input type="radio"/>	<input type="radio"/>	_____	
48	_____	<input type="radio"/>	<input type="radio"/>	<input type="radio"/>	_____	
49	_____	<input type="radio"/>	<input type="radio"/>	<input type="radio"/>	_____	
50	_____	<input type="radio"/>	<input type="radio"/>	<input type="radio"/>	_____	

CENTRIFUGAL COMPRESSOR DATA SHEETS (SI units)

ENQUIRY/ORDER NO. JOB NO.			ITEM NO.			
REVISION	BY	DATE	CHKD	DATE	APP'D	DATE

1 CONTROLS AND INSTRUMENTATION

2 **CONTROL PANEL: (5.4.3.1)**

3 CONTROLS AND INSTRUMENTATION PER SPECIFICATION

4 METHOD OF OPERATION

5 VIBRATION ISOLATORS STRIP HEATERS PURGE CONNECTIONS (5.4.4.1.2)

6 METAL CASE, GLASS FRONT, STEM-TYPE LIQUID FILLED/BIMETALLIC THERMOMETERS FURNISHED

7 LIQUID-FILLED PRESSURE GAUGES FURNISHED

8 HIGH VIBRATION DRIVER ALARM AND SHUTDOWN

9

10

11 **LOCAL GAUGE BOARD/PANEL:**

12 ON SKID LOCAL TO SKID _____

13

14

15 INSTRUMENT SUPPLIERS:

16 <input type="radio"/> PRESSURE GAUGES: (5.4.4.5)	MANUFACTURER _____	SIZE & TYPE _____
17 TEMPERATURE GAUGES:	MANUFACTURER _____	SIZE & TYPE _____
18 LEVEL GAUGES:	MANUFACTURER _____	SIZE & TYPE _____
19 DIFF. PRESSURE GAUGES:	MANUFACTURER _____	SIZE & TYPE _____
20 PRESSURE SWITCHES:	MANUFACTURER _____	SIZE & TYPE _____
21 DIFF. PRESSURE SWITCHES:	MANUFACTURER _____	SIZE & TYPE _____
22 TEMPERATURE SWITCHES:	MANUFACTURER _____	SIZE & TYPE _____
23 LEVEL SWITCHES;	MANUFACTURER _____	SIZE & TYPE _____
24 CONTROL VALVES:	MANUFACTURER _____	SIZE & TYPE _____
25 PRESSURE RELIEF VALVES:	MANUFACTURER _____	SIZE & TYPE _____
26 SIGHT FLOW INDICATORS:	MANUFACTURER _____	SIZE & TYPE _____
27 GAS FLOW INDICATOR:	MANUFACTURER _____	SIZE & TYPE _____
28 VIBRATION MEASUREMENT:	MANUFACTURER _____	SIZE & TYPE _____
29 TEMPERATURE MEASUREMENT:	MANUFACTURER _____	SIZE & TYPE _____
30 PRESSURE MEASUREMENT:	MANUFACTURER _____	SIZE & TYPE _____
31 FLOW MEASUREMENT:	MANUFACTURER _____	SIZE & TYPE _____
32 TACHOMETER:	MANUFACTURER _____	RANGE & TYPE _____
33 SOLENOID VALVES:	MANUFACTURER _____	SIZE & TYPE _____
34 ANNUNCIATOR:	MANUFACTURER _____	MODEL & NO. POINTS _____
35 ANTI-SURGE CONTROLLER:	MANUFACTURER _____	MODEL _____
36 LOAD SHARE CONTROLLER:	MANUFACTURER _____	MODEL _____
37 _____	_____	_____
38 _____	_____	_____

39 CONTROL PANEL DESIGN AND CONSTRUCTION

40

41

42

43

44 INSTRUMENTATION REQUIREMENTS: (5.4.1.2)

45 TUBING: MATERIAL _____ SIZE _____ FITTINGS _____

46 WIRING PROTECTION (5.4.3.2) (5.4.6.7) IN CONDUIT _____ ARMoured CABLE _____

47 TRANSMITTERS REQUIRED (5.4.5.1.1) ALL _____ SHUTDOWN _____

48 ALARM _____

49

50

CENTRIFUGAL COMPRESSOR DATA SHEETS (SI units)

ENQUIRY/ORDER NO.		ITEM NO.					
JOB NO.							
REVISION	BY	DATE	CHKD	DATE	APP'D	DATE	

COMPRESSOR INSTRUMENTATION SCHEDULE									
FUNCTION	PANEL IDENTIFICATION				ALARM & SHUTDOWN SWITCHES	PANEL IDENTIFICATION			
	L	B	C	D		L	B	C	D
<u>PRESSURE</u>					<u>A</u>	<u>I</u>			
LUBE OIL HEADER (NOTE 1)					<u>L</u>	<u>R</u>			
COMPRESSOR SUCTION EACH STAGE					<u>A</u>	<u>I</u>			
COMPRESSOR DISCHARGE EACH STAGE					<u>R</u>	<u>P</u>			
BALANCE CHAMBER(S)					<u>M</u>				
BALANCE DRUM									
PURGE GAS SUPPLY					O	O	HIGH RADIAL SHAFT VIBRATION		
O _____					O	O	HIGH AXIAL DISPLACEMENT		
O _____					O	O	OVER SPEED		
<u>DIFFERENTIAL PRESSURE</u>					O	O	REVERSE ROTATION		
BALANCE DRUM					O	O	HIGH JOURNAL BRG. METAL TEMP.		
BUFFER GAS					O	O	HIGH THRUST BRG. METAL TEMP.		
O _____					O	O	HIGH COMPR. SUCTION GAS TEMP.		
O _____					O	O	HIGH COMPR. DISCHARGE GAS TEMP.		
<u>TEMPERATURE</u>					O	O	LOW COMPR. SUCTION GAS TEMP.		
COMPRESSOR SUCTION EA. STG.					O	O	LOW COMPR. BALANCE DRUM ΔP		
COMPRESSOR DISCHARGE EA. STG.					O	O	LOW COMPR. SUCTION PRESS		
COMPRESSOR JOURNAL BEARING					O	O	HIGH COMPR. DISCHARGE PRESS		
COMPRESSOR THRUST BEARING					O	O	UNIT SHUTDOWN		
BEARING DRAIN					O	O	LOW BUFFER GAS DIFFER. PRESS		
O _____					O	O	LOW BUFFER GAS FLOW		
O _____					O	O	HIGH LEVEL IN SEPARATORS		
<u>LEVEL INDICATORS/CONTROLLERS</u>					O	O	_____		
SUCTION SEPARATOR EACH STAGE					O	O	_____		
INTERSTAGE SEPARATOR(S)					O	O	_____		
DISCHARGE SEPARATOR					O	O	_____		
O _____									
<u>PUSH BUTTON STATIONS:</u>					<u>MONITORS:</u>				
MAIN EQUIPMENT START					VIBRATION:				
MAIN EQUIPMENT STOP					AXIAL POSITION				
COMPRESSOR BLOCK IN					THRUST BEARING METAL TEMP.				
COMPRESSOR UNBLOCK					JOURNAL BEARING METAL TEMP.				
EMERGENCY STOP BUTTON(S)					_____				
O _____					_____				
<u>MISCELLANEOUS:</u>					<u>NOTES:</u>				
EQUIPMENT TACHOMETER					1) SEE ISO 10438 FOR OIL SYSTEM REQUIREMENTS				
EQUIPMENT SPEED CONTROL					2) ALL ALARMS AND TRIPS SHALL BE ANNUNCIATED				
COMPR. INLET CONTROLLER					3) PURCH. TO INDICATE PRESSURE GAUGES WHICH SHALL BE OIL-FILLED				
ANNUNCIATOR SYSTEM					4) PURCHASER TO INDICATE WHERE TRANSMITTERS ARE REQUIRED				
EQUIPMENT FLOW METER					5) THE FOLLOWING CODE IS USED FOR PANEL INDICATION				
GUIDE VANE POSITIONER					L = LOCALLY MOUNTED ON PIPING B = LOCAL GAUGE BOARD/PANEL				
SUCTION THROTTLE VALVE					C = CONTROL PANEL D = DISTRIBUTED CONTROL SYSTEM				
ANTI SURGE EQUIPMENT:					6) USE THE FOLLOWING CODE LETTERS TO SHOW DETAILS ETC.				
CAPACITY CONTROL EQUIPMENT:					F-FLUSH MOUNT ON FRONT H-PURCH. REMOTE MOUNT				
O _____					S-SURFACE MOUNT ON FRONT P-PURCH. SPPLY AND MOUNT				
O _____					M-MNT BY VENDOR OF PURCHR'S ITEM V-VENDOR SPPLY. AND MOUNT				
O _____					R-REAR OF PANEL MOUNT C- CUT-OUT FOR PURCH.'S ITEM				
O _____					D. INTERFACE WITH DCS				

CENTRIFUGAL COMPRESSOR DATA SHEETS (SI units)

ENQUIRY/ORDER NO.		ITEM NO.					
JOB NO.							
REVISION	BY	DATE	CH'KD	DATE	APP'D	DATE	

1 **SELF ACTING GAS SEAL (4.8.2.5)**

2 SEAL MFR. _____ MODEL _____

3 SERIAL NO. _____

4 Gas ANALYSIS SEAL GAS _____

5 BUFFER GAS _____

6 SEPARATION GAS _____

7 **SEAL CONFIGURATION**

8 SINGLE DOUBLE TANDEM TRIPLE OTHER _____

9 SEPARATION FROM OIL SYSTEM BY: CARBON RING LABYRINTHS

10 SEPARATION GAS _____ OTHER _____

11 **SEAL OPERATING CONDITIONS**

12 OPERATING CASE

NORMAL	MAX RATED	START-UP	SETTLE OUT

13 PRIMARY SEAL PRESSURE (kPa)

14 INTERMEDIATE SEAL PRESSURE (kPa)

15 SEAL GAS INLET TEMPERATURE (°C)

16 PRIMARY SEAL BACK PRESSURE (kPa)

17 INTERMEDIATE SEAL BACK PRESSURE (kPa)

18 BACK-UP SEAL BACK PRESSURE (kPa)

19 DEPRESSURISATION TIME (min) _____ * PROCESS UPSET CONDITION

20

21 SLOW ROLL REQUIRED: YES/NO SPEED (r/min) _____ DURATION (min) _____

22 BARRING DEVICE : YES/NO METHOD _____

23 REVERSE ROTATION CAPABILITY REQUIRED: YES/NO SPEED (r/min) _____ DURATION (min) _____

24 AT SEALING PRESSURES (kPa) _____ PRIMARY _____ INTERMEDIATE _____ BACK-UP _____

25 MAX. PERIPHERAL SPEED AT MAX. CONT. SPEED (m/s) _____ OUTER SEAL FACE DIAMETER (mm) _____

26 **MATERIALS OF CONSTRUCTION**

27 FACE _____ SLEEVES _____

28 SEAT _____

29 ELASTOMERS _____ SCREWS _____

30 HOUSING _____ SPRINGS _____

31 LABYRINTHS _____ NACE REQUIREMENTS _____

32

33 **GAS REQUIREMENTS**

34 (ALL DATA PER SEAL)

	NORMAL OPERATION			ON SEAL FAILURE (ALL GAS SEAL ELEMENTS)
	RUNNING	START-UP	SETTLE OUT	
35 SEAL GAS				
36 TYPE				
37 PRESSURE, MIN/MAX. (kPa)				
38 TEMPERATURE, MIN/MAX. (°C)				
39 FLOW, NORMAL/MAX. *(kg/h)	*		*	
40 BUFFER GAS				
41 TYPE				
42 PRESSURE, MIN/MAX. (kPa)				
43 TEMPERATURE, MIN/MAX. (°C)				
44 FLOW, NORMAL/MAX. *(kg/h)	*		*	
45 SEPARATION GAS				
46 TYPE				
47 PRESSURE, MIN/MAX. (kPa)				
48 TEMPERATURE, MIN/MAX. (°C)				
49 FLOW, NORMAL/MAX. *(kg/h)	*		*	
50 * MAX. TO BE GUARANTEED				

CENTRIFUGAL COMPRESSOR DATA SHEETS (US customary units)

ENQUIRY/ORDER NO.							
JOB NO.			ITEM NO.				
REVISION	BY	DATE	CHKD	DATE	APP'D	DATE	

1 APPLICABLE TO: PROPOSAL PURCHASE DESIGN AS BUILT

2 FOR _____ UNIT _____

3 SITE _____ SERIAL No. _____

4 SERVICE _____ NO. REQUIRED _____

5 CONTINUOUS INTERMITTENT STANDBY DRIVER TYPE (5.1.1) _____

6 VENDOR _____ O MODEL _____ DRIVER ITEM NO. _____

7 NOTE: INFORMATION TO BE COMPLETED: BY PURCHASER BY VENDOR

8 **OPERATING CONDITIONS**

(ALL DATA ON PER PROCESS STAGE)	NORMAL	RATED	OTHER CONDITIONS (5.1.2)			
			A	B	C	D
9 GAS FLOW						
10 <input type="radio"/> GAS HANDLED (ALSO SEE PAGE 2)						
11 <input type="radio"/> VOLUME FLOW, AT 14,7 PSI & 32 °F, Z=1, DRY (CFM)						
12 <input type="radio"/> MASS FLOW, [WET/DRY] (lb/h)						
13 INLET CONDITIONS (4.3.1)						
14 <input type="radio"/> PRESSURE (PSI)						
15 <input type="radio"/> TEMPERATURE (°F)						
16 <input type="radio"/> RELATIVE HUMIDTY (%)						
17 <input type="radio"/> MOLECULAR MASS (%)						
18 <input type="radio"/> ISENTROPIC EXPONENT C_p/C_v (K_1)						
19 <input type="checkbox"/> COMPRESSIBILITY (Z_1)						
20 <input type="checkbox"/> INLET VOLUME FLOW, [WET/DRY] (CFM)						
21 DISCHARGE CONDITIONS (4.3.1)						
22 <input type="checkbox"/> PRESSURE (PSI)						
23 <input type="checkbox"/> TEMPERATURE (°F)						
24 <input type="checkbox"/> ISENTROPIC EXPONENT (K_2)						
25 <input type="checkbox"/> COMPRESSIBILITY (Z_2)						
26 PERFORMANCE(4.1.4)(4.1.5)						
27 <input type="checkbox"/> POLYTROPIC HEAD, SPECIFIC COMPRESSION WORK FLANGE TO FLANGE (FT-LBF/LB)						
28 <input type="checkbox"/> POLYTROPIC EFFICIENCY FLANGE TO FLANGE (%)						
29 <input type="checkbox"/> COMPRESSOR MECHANICAL LOSSES (BHP)						
30 <input type="checkbox"/> COMPRESSOR ABSORBED POWER (BHP)						
31 <input type="checkbox"/> COMPRESSOR POWER REQUIRED, AT DRIVER COUPLING (BHP)						
32 <input type="checkbox"/> SPEED (r/min)						
33 <input type="radio"/> ESTIMATED SURGE AT ABOVE SPEED (CFM)						
34 <input type="checkbox"/> GUARANTEE POINT FLANGE TO FLANGE						
35 <input type="checkbox"/> PERFORMANCE CURVE NUMBER						
36 PROCESS CONTROL						
37 METHOD <input type="radio"/> SUCTION THROTTLING <input type="radio"/> VARIABLE <input type="radio"/> SPEED VARIATION <input type="radio"/> DISCHARGE <input type="radio"/> COOLED BYPASS						
38 FROM _____ (PSI) GUIDE VANES FROM _____ % BLOWOFF FROM _____						
39 TO _____ (PSI) (5.4.2.4) TO _____ % TO _____ TO _____						
40 SIGNAL <input type="radio"/> SOURCE (5.4.2.1)						
41 TYPE <input type="radio"/> ELECTRONIC <input type="radio"/> PNEUMATIC <input type="radio"/> OTHER _____ <input type="radio"/> RANGE _____ (mA) _____ (PSI)						
42 ANTI-SURGE SYSTEM (5.4.2.2)						
43 ANTI-SURGE BYPASS <input type="radio"/> MANUAL <input type="radio"/> AUTOMATIC <input type="radio"/> NONE						
44 A.-S. VALVE SIZING BY: _____ Vendor _____ OTHERS, A.-S. VALVE SUPPLIED BY: _____ Vendor _____ Purchaser						
45 A.-S. CONTROLLER SUPPLIED BY: _____ Vendor _____ Purchaser						
46 FLOW/PRESSURE SENSING ELEMENTS SUPPLIED BY: _____ Vendor _____ Purchaser						
47 FLOW/PRESSURE SENSING ELEMENT POSITIONS: <input type="radio"/> INLET <input type="radio"/> DISCHARGE						
48 LOAD SHARE CONTROLLER SUPPLIED BY: _____ Vendor _____ Purchaser						

CENTRIFUGAL COMPRESSOR DATA SHEETS (US customary units)

ENQUIRY/ORDER NO.				ITEM NO.			
JOB NO.							
REVISION	BY	DATE	CH'KD	DATE	APP'D	DATE	

1	OPERATING CONDITIONS (Continued) (5.1.2) (4.11.1.8)							
2	GAS ANALYSIS:	NORMAL	RATED	OTHER CONDITIONS				REMARKS: (4.11.1.3) (4.11.1.8)
3	O MOL% O			A	B	C	D	
4		MW						
5	AIR	28,966						
6	OXYGEN	32,000						
7	NITROGEN	28,016						
8	WATER VAPOUR	18,016						
9	CARBON MONOXIDE	28,010						
10	CARBON DIOXIDE	44,010						
11	HYDROGEN SULPHIDE	34,076						(4.11.1.7)
12	HYDROGEN	2,016						
13	METHANE	16,042						
14	ETHYLENE	28,052						
15	ETHANE	30,068						
16	PROPYLENE	42,078						
17	PROPANE	44,094						
18	I-BUTANE	58,120						
19	N-BUTANE	58,120						
20	I-PENTANE	72,146						
21	N-PENTANE	72,146						
22	HEXANE PLUS							
23								
24								
25	TOTAL							
26	AVG. MOL. MASS							
27	REMARKS:							
28								
29								
30								
31								
32								
33								
34								
35								
36								
37								
38								
39								
40								
41								
42								
43								
44								
45								
46								
47								
48								
49								
50								

STANDARDSISO.COM : Click to view the full PDF of ISO 10439:2002

CENTRIFUGAL COMPRESSOR DATA SHEETS (US customary units)

ENQUIRY/ORDER NO.		JOB NO.					
		ITEM NO.					
REVISION	BY	DATE	CH'KD	DATE	APP'D	DATE	

CONSTRUCTION FEATURES

SPEEDS:
 MAX. CONT. _____ RPM TRIP _____ RPM
 MAX. TIP SPEEDS: _____ FPS @ RATED SPEED
 _____ FPS @ MAX. CONT. SPEED

LATERAL CRITICAL SPEEDS (DAMPED)
 FIRST CRITICAL _____ RPM _____ MODE
 SECOND CRITICAL _____ RPM _____ MODE
 THIRD CRITICAL _____ RPM _____ MODE
 FOURTH CRITICAL _____ RPM _____ MODE

TRAIN LATERAL ANALYSIS REQUIRED (4.9.2.3)
 UNDAMPED STIFFNESS MAP REQUIRED (4.9.2.4)
 TRAIN TORSIONAL ANALYSIS REQUIRED (TUBINE DRIVEN TRAIN (4.9.4.6)

TORSIONAL CRITICAL SPEEDS:
 FIRST CRITICAL _____ RPM
 SECOND CRITICAL _____ RPM
 THIRD CRITICAL _____ RPM
 FOURTH CRITICAL _____ RPM

VIBRATION:
 ALLOWABLE TEST LEVEL _____ MIL (PEAK TO PEAK)

ROTATION, VIEWED FROM DRIVEN END [CW/CCW]
 MATERIALS INSPECTION REQUIREMENTS (6.2.2)
 SPECIAL CHARPY TESTING (4.11.3)
 RADIOGRAPHY REQUIRED FOR _____
 MAGNETIC PARTICLE REQUIRED FOR _____
 LIQUID PENETRANT REQUIRED FOR _____

CASING:
 MODEL _____
 CASING SPLIT _____
 Pressure design code (4.1.20) _____
 MATERIAL _____
 THICKNESS (IN) _____ CORR. ALLOW. (IN) _____
 MAX WORKING PRESS. _____ PSI
 MAX DESIGN PRESS. _____ PSI
 TEST PRESS (PSI) - HELIUM _____ HYDRO _____
 MAX. OPER. TEMP. _____ °F MIN. OPER. TEMP. _____ °F
 MAX. NO. OF IMPELLERS FOR CASING _____
 MAX. CASING CAPACITY VOLUME FLOW (CFM) _____
 RADIOGRAPH QUALITY YES NO
 CASING SPLIT SEALING _____
 SYSTEM RELIEF VALVE SET PT. (4.2.4) _____ PSI

DIAPHRAGMS:
 MATERIAL _____

IMPELLERS:
 NO. _____ DIAMETERS (IN) _____
 NO. VANES EACH IMPELLER _____

TYPE (OPEN, ENCLOSED, ETC.) _____
 SHAPE FABRICATION _____
 MATERIAL _____
 MAX. YIELD STRENGTH (PSI) _____
 HARDNESS [HB/HRC] MAX _____ MIN _____
 SMALLEST TIP INTERNAL WIDTH (IN) _____
 MAX. MACH. NO. @ IMPELLER EYE _____
 MAX. IMPELLER HEAD @ RATED SPEED (FT-LBF/LB) _____

SHAFT:
 MATERIAL _____
 DIA @ IMPELLERS (IN) _____ DIA @ COUPLING (IN) _____
 SHAFT END: _____ TAPERED _____ CYLINDRICAL
 MAX. YIELD STRENGTH (PSI) _____
 HARDNESS [HB/HRC] _____
 STRESS AT COUPLING (PSI) _____

BALANCE PISTON:
 MATERIAL _____ AREA _____ IN²
 FIXATION METHOD _____

SHAFT SLEEVES (4.8.1.2):
 AT INTERSTG. CLOSE CLEARANCE POINTS MATL _____
 AT SHAFT SEALS _____ MATL _____

LABYRINTHS:
 INTERSTAGE
 TYPE _____ MATERIAL _____
 BALANCE PISTON
 TYPE _____ MATERIAL _____

SHAFT SEALS: GAS SEALS use pages 10 to 12
 SEAL TYPE (4.8.1.3) _____
 SETTLING OUT PRESSURE (PSI) _____
 SPECIAL OPERATION (4.8.1.1) _____
 SUPPLEMENTAL DEVICE REQUIRED FOR CONTACT SEALS (4.8.2.2) TYPE _____
 BUFFER GAS SYSTEM REQUIRED (4.8.2.4) (SEE ALSO PAGE 10)
 TYPE BUFFER GAS _____
 BUFFER GAS CONTROL SYSTEM SCHEMATIC BY VENDOR
 PRESSURIZING GAS FOR SUBATMOSPHERIC SEALS (4.8.2.5)
 TYPE SEAL _____
 INNER LEAKAGE GUAR. (GAL/DAY/SEAL) _____
 BUFFER GAS REQUIRED FOR:
 AIR RUN-IN OTHER _____

BUFFER GAS FLOW (PER SEAL):
 NORM: _____ LB/min @ _____ PSI ΔP _____
 MAX: _____ LB/min @ _____ PSI ΔP _____

LUBE/SEAL OIL SYSTEM SEPARATE _____ COMBINED _____ (4.10.3)

BEARING HOUSING CONSTRUCTION:
 TYPE (SEPARATE, INTEGRAL) _____ SPLIT _____
 MATERIAL _____

CENTRIFUGAL COMPRESSOR DATA SHEETS (US customary units)

ENQUIRY/ORDER NO.		JOB NO.						ITEM NO.					
REVISION	BY	DATE	CH'KD	DATE	APP'D	DATE							

1 CONSTRUCTION FEATURES (CONTINUED)

2 BEARINGS AND BEARING HOUSINGS

3	RADIAL	DRIVE END	NON-DRIVE END	THRUST	ACTIVE	INACTIVE
4	<input type="checkbox"/> TYPE			<input type="checkbox"/> TYPE		
5	<input type="checkbox"/> MANUFACTURER			<input type="checkbox"/> MANUFACTURER		
6	<input type="checkbox"/> LENGTH (IN)			<input type="checkbox"/> UNIT LOADING (MAX) (PSI)		
7	<input type="checkbox"/> SHAFT DIA (IN)			<input type="checkbox"/> UNIT LOAD (ULT) (PSI)		
8	<input type="checkbox"/> Unit load (Act/allow) (PSI)			<input type="checkbox"/> AREA (IN ²)		
9	<input type="checkbox"/> BASE MATERIAL			<input type="checkbox"/> NO. PADS		
10	<input type="checkbox"/> BABBIT THICKNESS (IN)			<input type="checkbox"/> PIVOT: CTR/OFFSET (%)		
11	<input type="checkbox"/> NO. PADS			<input type="checkbox"/> PAD BASE MATERIAL		
12	<input type="checkbox"/> LOAD: BETWEEN/ON PAD			<input type="checkbox"/>		
13	<input type="checkbox"/> PIVOT: CTR/OFFSET (%)			LUBRICATION: <input type="radio"/> FLOODED <input type="radio"/> DIRECTED		
14	<input type="checkbox"/> BEARING SPAN (IN)			THRUST COLLAR: <input type="radio"/> INTEGRAL <input type="radio"/> REPLACEABLE		
15	<input type="checkbox"/> SQUEEZE FILM DAMPING			MATERIAL _____		
16	<input type="checkbox"/>					

17 BEARING TEMPERATURE DEVICES

18 SEE ATTACHED API 670 DATA SHEET

19 THERMISTORS

20 TYPE _____ POS. TEMP COEFF _____ NEG. TEMP COEFF _____

21 TEMP SWITCH & INDICATOR BY: _____ PURCH _____ MFR

22 THERMOCOUPLES

23 SELECTOR SWITCH & INDICATOR BY: _____ PURCH _____ MFR

24 RESISTANCE TEMP DETECTORS

25 RESISTANCE MATL. _____ OHM

26 SELECT SWITCH & INDICATOR BY: _____ PURCH _____ MFR

27 LOCATION-JOURNAL BRG

28 NO. _____ EA. PAD EVERY OTHER PAD PER BRG

29 OTHER _____

30 LOCATION-THRUST BRG

31 NO. _____ EA. PAD EVERY OTHER PAD PER BRG

32 OTHER _____

33 MONITOR SUPPLIED BY (5.4.7.3) _____

34 LOCATION _____ ENCLOSURE _____

35 MFR _____ MODEL _____

36 SCALE _____ ALARM SET @ _____ °F

37 SHTDWN SET @ _____ °F TIME DELAY _____ SEC

VIBRATION DETECTORS:

18 SEE ATTACHED API 670 DATA SHEET

19 TYPE _____ MODEL _____

20 MFR _____

21 NO. AT EA SHAFT BEARING _____ TOTAL NO. _____

22 OSCILLATOR-DETECTORS SUPPLIED BY _____

23 MFR _____ MODEL _____

24 MONITOR SUPPLIED BY (5.4.7.2) _____

25 LOCATION _____ ENCLOSURE _____

26 MFR _____ MODEL _____

27 SCALE _____ ALARM SET @ _____ MIL

28 SHTDWN: SET @ _____ MIL TIME DELAY _____ SEC

AXIAL POSITION DETECTOR:

18 SEE ATTACHED API 670 DATA SHEET

19 TYPE _____ MODEL _____

20 MFR _____ NO. REQUIRED _____

21 OSCILLATOR-DEMODULATOR SUPPLIED BY: _____

22 MFR _____ MODEL _____

23 MONITOR SUPPLIED BY (5.4.7.2) _____

24 LOCATION _____ ENCLOSURE _____

25 MFR _____ MODEL _____

26 SCALE _____ ALARM SET @ _____ MIL

27 SHTDWN SET @ _____ IN TIME DELAY _____ SEC

38 CONNECTIONS

39	COMPRESSOR CASING	<input type="radio"/> DESIGN APPROVAL REQUIRED (4.11.2.12)	<input type="checkbox"/> SIZE	<input type="checkbox"/> RATING/FACING	<input type="radio"/> POSITION (4.4.2.1)	<input type="radio"/> FLANGED OR STUDDER (4.4.2.1)	<input type="radio"/> MATING FLG & GASKET BY VENDOR (4.4.2.2)	GAS VELOCITY FPS
40	INLET							
41	DISCHARGE							
42								
43								
44								
45								
46								
47								
48								
49								
50								

CENTRIFUGAL COMPRESSOR DATA SHEETS (US customary units)

ENQUIRY/ORDER NO.		JOB NO.					
JOB NO.		ITEM NO.					
REVISION	BY	DATE	CH'KD	DATE	APP'D	DATE	

1	<input type="checkbox"/> OTHER CONNECTIONS [DIRECT/SKID EDGE]			<input type="checkbox"/> ALLOWABLE PIPING FORCES AND MOMENTS:					
3	SERVICE:			CONNECTION		INLET		DISCHARGE	
4	LUBE -OIL INLET	NO	SIZE	TYPE	AXIAL	LBF	MOMT FT-LBF	FORCE LBF	MOMT FT-LBF
5	LUBE-OIL OUTLET				VERTICAL				
6	SEAL-OIL INLET				HORIZ. 90°				
7	SEAL-OIL OUTLET				CONNECTION				
8	CASING DRAINS				AXIAL				
9	STAGE DRAINS				VERTICAL				
10	VENTS				HORIZ. 90°				
11	COOLING WATER								
12	PRESSURE								
13	TEMPERATURE								
14	PURGE FOR:				<input type="checkbox"/> VIBRATION TRANSDUCER [CASING/BEARING HOUSING] (5.4.7.4)				
15	BRG. HOUSING				<input type="checkbox"/> SEE ATTACHED API 670 DATA SHEET				
16	BTWN BRG & SEAL				<input type="checkbox"/> TYPE _____ <input type="checkbox"/> MODEL				
17	BTWN SEAL & GAS				<input type="checkbox"/> MFR _____ NO. REQUIRED _____				
18	SOLVENT INJECTION				<input type="checkbox"/> LOCATION _____				
19					<input type="checkbox"/> OSCILATOR-DEMODULATORS SUPPLIED BY _____				
20					<input type="checkbox"/> MFR _____ <input type="checkbox"/> MODEL _____				
21	<input type="checkbox"/> INDIVIDUAL STAGE DRAINS REQUIRED (4.4.3.2)				<input type="checkbox"/> MONITOR SUPPLIED BY (5.4.7.5) _____				
22	<input type="checkbox"/> VALVED & BLINDED				<input type="checkbox"/> LOCATION _____ ENCLOSURE _____				
23	<input type="checkbox"/> VALVED & BLINDED & MANIFOLD				<input type="checkbox"/> MFR _____ <input type="checkbox"/> MODEL _____				
24	<input type="checkbox"/> VALVE ACTUATION <input type="checkbox"/> MANUAL <input type="checkbox"/> AUTO				<input type="checkbox"/> SCALE RANGE _____ <input type="checkbox"/> ALARM: <input type="checkbox"/> SET @ _____ IN/SEC ²				
25	<input type="checkbox"/> _____				<input type="checkbox"/> SHTDWN <input type="checkbox"/> SET @ _____ IN/SEC ² <input type="checkbox"/> TIME DELAY _____ SEC				
26	ACCESSORIES								
27	<input type="checkbox"/> SEE ATTACHED ISO 14691 DATA SHEET FOR FULL DETAILS ON ROTATING ELEMENTS AND SHAFT ENDS								
28	COUPLING FURNISHED BY _____								
29	MANUFACTURER _____ TYPE _____ MODEL _____								
30	COUPLING GUARD FURNISHED BY: _____								
31	TYPE: <input type="checkbox"/> FULLY ENCLOSED <input type="checkbox"/> SEMI-OPEN <input type="checkbox"/> OTHER MATERIAL: _____								
32	COUPLING DETAILS								
33	<input type="checkbox"/> SHAFT MOUNTING _____				<input type="checkbox"/> VENDOR MOUNT HALF COUPLING				
34	<input type="checkbox"/> MAX O.D IN _____				<input type="checkbox"/> IDLING ADAPTER/SOLO PLATE REQUIRED (5.2.4)				
35	<input type="checkbox"/> HUB MASS _____ LB				LUBRICATING REQUIREMENTS:				
36	<input type="checkbox"/> SPACER LENGTH _____ IN				<input type="checkbox"/> NON-LUBE <input type="checkbox"/> GREASE <input type="checkbox"/> CONT. OIL LUBE <input type="checkbox"/> OTHER				
37	<input type="checkbox"/> SPACER MASS _____ LB				QUANTITY PER HUB _____ GPM				
38	<input type="checkbox"/> PLUG & RING GAUGES REQUIRED (5.2.5)								
39	MOUNTING PLATES								
40	<input type="checkbox"/> BASEPLATES: FURNISHED BY (5.3.1.1) _____				<input type="checkbox"/> SOLEPLATES: FURNISHED BY: _____				
41	<input type="checkbox"/> COMPRESSOR ONLY (5.3.2.8) <input type="checkbox"/> DRIVER <input type="checkbox"/> GEAR				<input type="checkbox"/> THICKNESS _____ IN				
42	<input type="checkbox"/> OTHER _____				<input type="checkbox"/> SUBSOLE PLATES REQUIRED (5.3.3.2)				
43	<input type="checkbox"/> DRIP TRIM <input type="checkbox"/> LEVELLING PADS (5.3.2.2.)				<input type="checkbox"/> LEVELLING BLOCKS REQUIRED				
44	<input type="checkbox"/> COLUMN MOUNTING (5.3.2.3)				<input type="checkbox"/> STAINLESS STEEL SHIM				
45	<input type="checkbox"/> SUB-SOLE PLATES REQUIRED (5.3.2.5)				<input type="checkbox"/> THICKNESS _____ IN				
46	<input type="checkbox"/> STAINLESS STEEL SHIM THICKNESS _____ IN				<input type="checkbox"/> DRIVER <input type="checkbox"/> GEAR <input type="checkbox"/> COMPRESSOR				
47	<input type="checkbox"/> PRIMER FOR EPOXY GROUT REQUIRED (5.3.1.2)				<input type="checkbox"/> PRIMER FOR EPOXY GROUT REQUIRED (5.3.1.2)				
48	TYPE _____				TYPE _____				
49	<input type="checkbox"/> LIMIT OF PIPING (5.5.1.3) _____								
50									

CENTRIFUGAL COMPRESSOR DATA SHEETS (US customary units)

ENQUIRY/ORDER NO.		ITEM NO.					
JOB NO.							
REVISION	BY	DATE	CH'KD	DATE	APP'D	DATE	

1 **LOCATION, SITE DATA, UTILITIES AND MASS & SPACE REQUIREMENTS**

2 **LOCATION: COMPRESSOR SKID**

3 INDOOR HEATED UNDER ROOF

4 OUTDOOR UNHEATED PARTIAL SIDES

5 GRADE MEZZANINE _____

6 WINTERIZATION (4.1.10) REQD. TROPICALISATION REQD. (5.4.6.6)

7 **SITE DATA:**

8 ELEVATION ____ FT BAROMETER _____ PSI

9 RANGE OF AMBIENT TEMPS:

10 _____ °F RELATIVE HUMIDITY _____

11 SITE RATED _____

12 NORMAL _____

13 MAXIMUM _____

14 MINIMUM _____

15 **LOCATION: AUXILIARY EQUIPMENT**

16 CONTROL PANEL _____

17 LUBE/SEAL OIL CONSOLE _____

18 NITROGEN GENERATOR _____

19 _____

20 **UNUSUAL CONDITIONS:** DUST FUMES

21 OTHER (4.11.1.8) _____

22

23 **AREA CLASSIFICATION (4.1.16)**

	ZONE	GAS GROUP	TEMP CLASS
24 COMPRESSOR SKID	_____	_____	_____
25 LUBE/SEAL OIL CONSOLE	_____	_____	_____
26 CONTROL PANEL	_____	_____	_____
27 NITROGEN GENERATOR	_____	_____	_____
28 _____	_____	_____	_____
29 _____	_____	_____	_____

30 **UTILITY CONDITIONS:**

	DRIVERS	HEATING
31 STEAM:		
32 INLET MIN _____ PSI _____ °F _____ PSI _____ °F		
33 NORM _____ PSI _____ °F _____ PSI _____ °F		
34 MAX _____ PSI _____ °F _____ PSI _____ °F		
35 EXHAUST. MIN _____ PSI _____ °F _____ PSI _____ °F		
36 NORM _____ PSI _____ °F _____ PSI _____ °F		
37 MAX _____ PSI _____ °F _____ PSI _____ °F		

38 **ELECTRICAL SUPPLY (5.4.6.1)**

	DRIVERS	HEATING	CONTROL	SHUTDOWN
39 VOLTAGE _____	_____	_____	_____	_____
40 HERTZ _____	_____	_____	_____	_____
41 PHASE _____	_____	_____	_____	_____

42

43 **COOLING WATER:**

44 TEMP. INLET _____ °F MAX RETURN _____ °F

45 PRESS NORM _____ PSI DESIGN _____ PSI

46 MIN RETURN _____ PSI MAX ALLOW ΔP _____ PSI

47 WATER SOURCE _____

48 **INSTRUMENT AIR:**

49 MAX PRESS _____ PSI MIN PRESS _____ PSI

50 **NITROGEN:**

MAX PRESS _____ PSI MIN PRESS _____ PSI

TOTAL UTILITY CONSUMPTION:

COOLING WATER _____ GPM

STEAM, NORMAL _____ LB/HR

STEAM, MAX _____ LB/HR

INSTRUMENT AIR _____ CFM

POWER (DRIVER) _____ BHP

POWER (AUXILIARIES) _____ BHP

POWER (HEATERS) _____ BHP

PURGE [AIR/N₂] _____ LB/HR

MASSES (LB):

COMPR. _____ GEAR _____ DRIVER _____ BASE _____

ROTORS: COMPR. _____ DRIVER _____ GEAR _____

COMPR UPPER CASE/CARTRIDGE _____

SOUR SEAL OIL TRAPS _____

LUBE OIL CONSOLE (WET/DRY) _____

SEAL OIL CONSOLE (WET/DRY) _____

OVERHEAD BRG RUNDOWN TANK (WET/ DRY) _____

NITROGEN GENERATOR PACKAGE _____

CONTROL PANEL _____

MAX. FOR MAINTENANCE (IDENTIFY) _____

TOTALS FOR SHIPPING _____

SPACE REQUIREMENTS (FT):

COMPLETE UNIT: L _____ W _____ H _____

LUBE OIL CONSOLE: L _____ W _____ H _____

SEAL OIL CONSOLE: L _____ W _____ H _____

O'HD S.O. TANK L _____ W _____ H _____

O'HD BRG. R.D. TANK L _____ W _____ H _____

N₂ GEN PACKAGE L _____ W _____ H _____

CONTROL PANEL L _____ W _____ H _____

REMARKS:

CENTRIFUGAL COMPRESSOR DATA SHEETS (US customary units)

ENQUIRY/ORDER NO.		ITEM NO.				
JOB NO.						
REVISION	BY	DATE	CH'KD	DATE	APP'D	DATE

INSPECTION AND TEST				SPECIFICATIONS AND MISCELLANEOUS		
1	<input type="checkbox"/> SHOP INSPECTION AND TESTS: (6.1.4) (6.2.1.3)			NOISE SPECIFICATIONS: (4.1.11)		
2		<u>REQ'D</u>	<u>WITNS'D</u>	<u>OBSV'D</u>	<input type="radio"/> APPLICABLE TO MACHINE:	
3					SEE SPECIFICATION _____	
4	SHOP INSPECTION	<input type="radio"/>			<input type="radio"/> APPLICABLE TO NEIGHBOURHOOD:	
5	CLEANLINESS (6.2.1.5)	<input type="radio"/>			SEE SPECIFICATION _____	
6	HYDROSTATIC	<input checked="" type="radio"/>	<input type="radio"/>	<input type="radio"/>	ACOUSTIC HOUSING: <input type="radio"/> YES <input type="radio"/> NO	
7	IMPELLER OVERSPEED	<input checked="" type="radio"/>	<input type="radio"/>	<input type="radio"/>	APPLICABLE REGULATIONS: (4.1.21)	
8	MECHANICAL RUN	<input checked="" type="radio"/>	<input type="radio"/>	<input type="radio"/>	_____	
9	<input type="checkbox"/> CONTRACT COUPLING				_____	
	<input type="checkbox"/> IDLING ADAPTOR(S)				_____	
10	<input type="checkbox"/> CONTRACT PROBES				_____	
	<input type="checkbox"/> SHOP PROBES				_____	
11	VARY LUBE & SEAL OIL PRESSURES AND TEMPERATURES (6.3.4.2.5)				PAINTING:	
12	POLAR FORM VIB DATA (6.3.4.3.3)	<input type="radio"/>			<input type="radio"/> MANUFACTURER'S STD.	
13	TAPE RECORD VIB (6.3.4.3.6)	<input type="radio"/>			<input type="radio"/> OTHER _____	
14	TAPE DATA TO PURCHASER (6.3.4.3.7)	<input type="radio"/>			SHIPMENT: (6.4.1)	
15	RESIDUAL UNBALANCE CHECK (4.9.3.1)	<input type="radio"/>	<input type="radio"/>	<input type="radio"/>	<input type="radio"/> DOMESTIC <input type="radio"/> EXPORT <input type="radio"/> EXPORT BOXING REQD.	
16	SHAFT END SEAL INSP. (6.3.4.4.1)	<input type="radio"/>			<input type="radio"/> OUTDOOR STORAGE MORE THAN 6 MONTHS (6.4.1)	
17	GAS LEAK TEST DISCH. PRESS (6.3.5.2) (6.3.5.3)	<input type="radio"/>	<input type="radio"/>	<input type="radio"/>	SPARE ROTOR ASSEMBLY PACKAGED FOR (6.4.3)	
18	<input type="radio"/> BEFORE <input type="radio"/> AFTER MECH RUN				<input type="radio"/> HORIZONTAL STORAGE <input type="radio"/> VERTICAL STORAGE	
19	PERFORMANCE TEST [GAS/AIR] (6.3.6.2)	<input type="radio"/>	<input type="radio"/>	<input type="radio"/>	MISCELLANEOUS:	
20	<input type="radio"/> ISO 5389 <input type="radio"/> PTC 10				<input type="checkbox"/> RECOMMENDED STRAIGHT RUN OF PIPE DIAMETERS	
21	SINGLE POINT TEST	<input type="radio"/>	<input type="radio"/>	<input type="radio"/>	BEFORE SUCTION _____	
22	_____ POINTS TEST	<input type="radio"/>	<input type="radio"/>	<input type="radio"/>	<input type="radio"/> VENDOR'S REVIEW & COMMENTS ON PURCHASER'S PIPING & FOUNDATION (4.1.15) (5.3.2)	
23	_____ SPEED LINES	<input type="radio"/>	<input type="radio"/>	<input type="radio"/>	<input type="radio"/> COMPRESSOR TO BE SUITABLE FOR FIELD RUN IN ON AIR (4.1.18)	
24	_____	<input type="radio"/>	<input type="radio"/>	<input type="radio"/>	<input type="radio"/> PROVISION FOR LIQUID INJECTION (4.1.12) _____	
25	_____	<input type="radio"/>	<input type="radio"/>	<input type="radio"/>	<input type="radio"/> VENDOR'S REVIEW & COMMENTS ON PURCHASER'S CONTROL SYSTEMS (5.4.1.1)	
26	COMP. WITH SHOP DRIVER	<input type="radio"/>	<input type="radio"/>	<input type="radio"/>	<input type="radio"/> EXTENT OF PROCESS PIPING BY VENDOR (5.5.3.1) _____	
27	COMP. WITH JOB DRIVER	<input type="radio"/>	<input type="radio"/>	<input type="radio"/>	<input type="radio"/> SHOP FITUP OF VENDOR PROCESS PIPING (6.4.3)	
28	USE SHOP LUBE/SEAL OIL SYSTEM	<input type="radio"/>	<input type="radio"/>	<input type="radio"/>	<input type="radio"/> WELDING HARDNESS TESTING (6.2.1.6)	
29	USE JOB LUBE/SEAL OIL SYSTEM	<input type="radio"/>	<input type="radio"/>	<input type="radio"/>	<input type="radio"/> INSPECTION CHECKLIST REQUIRED (6.1.6)	
30	CHECK BRG'S AND SEALS AFTER TEST	<input type="radio"/>	<input type="radio"/>	<input type="radio"/>	<input type="radio"/> TECHNICAL DATA MANUAL REQUIRED (7.3.6.4)	
31	NITROGEN GENERATOR PACKAGE TEST	<input type="radio"/>	<input type="radio"/>	<input type="radio"/>	_____	
32	DRY GAS SEAL SYSTEM TEST	<input type="radio"/>	<input type="radio"/>	<input type="radio"/>	_____	
33	DRY GAS SEAL TESTING AT SEAL VDR	<input type="radio"/>	<input type="radio"/>	<input type="radio"/>	_____	
34	CONTROL PANEL FUNCTIONAL TEST	<input type="radio"/>	<input type="radio"/>	<input type="radio"/>	_____	
35	MECHANICAL RUN USING SPARE ELEMENTS	<input type="radio"/>	<input type="radio"/>	<input type="radio"/>	_____	
36	COMPLETE UNIT TEST (6.3.6.3)	<input type="radio"/>	<input type="radio"/>	<input type="radio"/>	_____	
37	TORSIONAL VIB MEAS	<input type="radio"/>	<input type="radio"/>	<input type="radio"/>	_____	
38	TANDEM TEST (6.3.6.4)	<input type="radio"/>	<input type="radio"/>	<input type="radio"/>	_____	
39	GEAR TEST (6.3.6.5)	<input type="radio"/>	<input type="radio"/>	<input type="radio"/>	_____	
40	HELIUM LEAK TEST (6.3.6.6)	<input type="radio"/>	<input type="radio"/>	<input type="radio"/>	_____	
41	SOUND LEVEL TEST (6.3.6.7)	<input type="radio"/>	<input type="radio"/>	<input type="radio"/>	_____	
42	FULL LOAD/SPEED/PRESS TEST (6.3.6.10)	<input type="radio"/>	<input type="radio"/>	<input type="radio"/>	_____	
43	HYDRAULIC COUPLING INSP (6.3.6.11)	<input type="radio"/>	<input type="radio"/>	<input type="radio"/>	_____	
44	CERTIFIED COPIES OF TEST DATA	<input type="radio"/>	<input type="radio"/>	<input type="radio"/>	_____	
45	_____	<input type="radio"/>	<input type="radio"/>	<input type="radio"/>	_____	
46	_____	<input type="radio"/>	<input type="radio"/>	<input type="radio"/>	_____	
47	_____	<input type="radio"/>	<input type="radio"/>	<input type="radio"/>	_____	
48	_____	<input type="radio"/>	<input type="radio"/>	<input type="radio"/>	_____	
49	_____	<input type="radio"/>	<input type="radio"/>	<input type="radio"/>	_____	
50						

CENTRIFUGAL COMPRESSOR DATA SHEETS (US customary units)

ENQUIRY/ORDER NO.			ITEM NO.			
JOB NO.						
REVISION	BY	DATE	CHKD	DATE	APP'D	DATE

1 **CONTROLS AND INSTRUMENTATION**

2 **CONTROL PANEL: (5.4.3.1)**

3 CONTROLS AND INSTRUMENTATION PER SPECIFICATION

4 METHOD OF OPERATION

5 VIBRATION ISOLATORS STRIP HEATERS PURGE CONNECTIONS (5.4.4.1.2)

6 METAL CASE, GLASS FRONT, STEM-TYPE LIQUID FILLED/BI METALLIC THERMOMETERS FURNISHED

7 LIQUID-FILLED PRESSURE GAUGES FURNISHED

8 HIGH VIBRATION DRIVER ALARM AND SHUTDOWN

9

10

11 **LOCAL GAUGE BOARD/PANEL:**

12 ON SKID LOCAL TO SKID _____

13

14

15 **INSTRUMENT SUPPLIERS:**

16 PRESSURE GAUGES: (5.4.4.5) MANUFACTURER _____ SIZE & TYPE _____

17 TEMPERATURE GAUGES: MANUFACTURER _____ SIZE & TYPE _____

18 LEVEL GAUGES: MANUFACTURER _____ SIZE & TYPE _____

19 DIFF. PRESSURE GAUGES: MANUFACTURER _____ SIZE & TYPE _____

20 PRESSURE SWITCHES: MANUFACTURER _____ SIZE & TYPE _____

21 DIFF. PRESSURE SWITCHES: MANUFACTURER _____ SIZE & TYPE _____

22 TEMPERATURE SWITCHES: MANUFACTURER _____ SIZE & TYPE _____

23 LEVEL SWITCHES; MANUFACTURER _____ SIZE & TYPE _____

24 CONTROL VALVES: MANUFACTURER _____ SIZE & TYPE _____

25 PRESSURE RELIEF VALVES: MANUFACTURER _____ SIZE & TYPE _____

26 SIGHT FLOW INDICATORS: MANUFACTURER _____ SIZE & TYPE _____

27 GAS FLOW INDICATOR: MANUFACTURER _____ SIZE & TYPE _____

28 VIBRATION MEASUREMENT: MANUFACTURER _____ SIZE & TYPE _____

29 TEMPERATURE MEASUREMENT: MANUFACTURER _____ SIZE & TYPE _____

30 PRESSURE MEASUREMENT: MANUFACTURER _____ SIZE & TYPE _____

31 FLOW MEASUREMENT: MANUFACTURER _____ SIZE & TYPE _____

32 TACHOMETER: MANUFACTURER _____ RANGE & TYPE _____

33 SOLENOID VALVES: MANUFACTURER _____ SIZE & TYPE _____

34 ANNUNCIATOR: MANUFACTURER _____ MODEL & NO. POINTS _____

35 ANTI-SURGE CONTROLLER MANUFACTURER _____ MODEL _____

36 LOAD SHARE CONTROLLER MANUFACTURER _____ MODEL _____

37 _____

38 _____

39 **CONTROL PANEL DESIGN AND CONSTRUCTION**

40

41

42

43

44 **INSTRUMENTATION REQUIREMENTS (5.4.1.2):**

45 **TUBING:** MATERIAL _____ SIZE _____ FITTINGS _____

46 WIRING PROTECTION (5.4.3.2) (5.4.6.7) IN CONDUIT _____ ARMoured CABLE _____

47 TRANSMITTERS REQUIRED (5.4.5.1.1) ALL _____ SHUTDOWN _____

48 ALARM _____

49

50

CENTRIFUGAL COMPRESSOR DATA SHEETS (US customary units)

ENQUIRY/ORDER NO.		ITEM NO.					
JOB NO.							
REVISION	BY	DATE	CHKD	DATE	APP'D	DATE	

COMPRESSOR INSTRUMENTATION SCHEDULE									
FUNCTION	PANEL IDENTIFICATION				PANEL IDENTIFICATION				ALARM & SHUTDOWN SWITCHES
	L	B	C	D	L	B	C	D	
<u>PRESSURE</u>					<u>A</u>	<u>T</u>			
LUBE OIL HEADER (NOTE 1)					<u>L</u>	<u>R</u>			
COMPRESSOR SUCTION EACH STAGE					<u>A</u>	<u>I</u>			
COMPRESSOR DISCHARGE EACH STAGE					<u>R</u>	<u>P</u>			
BALANCE CHAMBER(S)					<u>M</u>				
BALANCE DRUM									
PURGE GAS SUPPLY									
O _____									
O _____									
<u>DIFFERENTIAL PRESSURE</u>									
BALANCE DRUM									
BUFFER GAS									
O _____									
O _____									
<u>TEMPERATURE</u>									
COMPRESSOR SUCTION EA. STG.									
COMPRESSOR DISCHARGE EA. STG.									
COMPRESSOR JOURNAL BEARING									
COMPRESSOR THRUST BEARING									
BEARING DRAIN									
O _____									
O _____									
<u>LEVEL INDICATORS/CONTROLLERS</u>									
SUCTION SEPARATOR EACH STAGE									
INTERSTAGE SEPARATOR(S)									
DISCHARGE SEPARATOR									
O _____									
<u>PUSH BUTTON STATIONS:</u>									
MAIN EQUIPMENT START									
MAIN EQUIPMENT STOP									
COMPRESSOR BLOCK IN									
COMPRESSOR UNBLOCK									
EMERGENCY STOP BUTTON(S)									
O _____									
<u>MISCELLANEOUS:</u>									
EQUIPMENT TACHOMETER									
EQUIPMENT SPEED CONTROL									
COMPR. INLET CONTROLLER									
ANNUNCIATOR SYSTEM									
EQUIPMENT FLOW METER									
GUIDE VANE POSITIONER									
SUCTION THROTTLE VALVE									
ANTI SURGE EQUIPMENT:									
CAPACITY CONTROL EQUIPMENT:									
O _____									
O _____									
O _____									

A	T	FUNCTION
L	R	
A	I	
R	P	
M		

O	O	HIGH RADIAL SHAFT VIBRATION				
O	O	HIGH AXIAL DISPLACEMENT				
O	O	OVER SPEED				
O	O	REVERSE ROTATION				
O	O	HIGH JOURNAL BRG. METAL TEMP.				
O	O	HIGH THRUST BRG. METAL TEMP.				
O	O	HIGH COMPR. SUCTION GAS TEMP.				
O	O	HIGH COMPR. DISCHARGE GAS TEMP.				
O	O	LOW COMPR. SUCTION GAS TEMP.				
O	O	LOW COMPR. BALANCE DRUM ΔP				
O	O	LOW COMPR. SUCTION PRESS				
O	O	HIGH COMPR. DISCHARGE PRESS				
O	O	UNIT SHUTDOWN				
O	O	LOW BUFFER GAS DIFFER. PRESS				
O	O	LOW BUFFER GAS FLOW				
O	O	HIGH LEVEL IN SEPARATORS				
O	O	_____				
O	O	_____				
O	O	_____				

MONITORS:

VIBRATION:			
AXIAL POSITION			
THRUST BEARING METAL TEMP.			
JOURNAL BEARING METAL TEMP.			

- NOTES:**
- SEE ISO 10438 FOR OIL SYSTEM REQUIREMENTS
 - ALL ALARMS AND TRIPS SHALL BE ANNUNCIATED
 - PURCH. TO INDICATE PRESSURE GAUGES WHICH SHALL BE OIL-FILLED
 - PURCHASER TO INDICATE WHERE TRANSMITTERS ARE REQUIRED
 - THE FOLLOWING CODE IS USED FOR PANEL INDICATION
 L = LOCALLY MOUNTED ON PIPING B = LOCAL GAUGE BOARD/PANEL
 C = CONTROL PANEL D = DISTRIBUTED CONTROL SYSTEM
 - USE THE FOLLOWING CODE LETTERS TO SHOW DETAILS ETC.
 F-FLUSH MOUNT ON FRONT H-PURCHR. REMOTE MOUNT
 S-SURFACE MOUNT ON FRONT P-PURCHR. SPPLY AND MOUNT
 M-MNT BY VENDOR OF PURCHR'S ITEM V-VENDOR SPPLY. AND MOUNT
 R-REAR OF PANEL MOUNT C- CUT-OUT FOR PURCH'S ITEM
 D. INTERFACE WITH DCS

CENTRIFUGAL COMPRESSOR DATA SHEETS (US customary units)

ENQUIRY/ORDER NO.		ITEM NO.					
JOB NO.							
REVISION	BY	DATE	CH'KD	DATE	APP'D	DATE	

SELF ACTING GAS SEAL INSTRUMENTATION SCHEDULE (NOTE 1) (4.8.2.5)											
FUNCTION		PANEL IDENTIFICATION				ALARM & SHUTDOWN					
(EACH SEAL/SEAL SUPPLY)		L	B	C	D	A	I	L	B	C	D
PRESSURE						L	R	FUNCTION			
5	<input type="radio"/> SEAL GAS SUPPLY	—	—	—	—	A	I				
6	<input type="radio"/> BUFFER GAS SUPPLY (NOTE 3)	—	—	—	—	R	P				
7	<input type="radio"/> SEPARATION GAS SUPPLY (NOTE 2)	—	—	—	—	M					
8	<input type="radio"/> PRIMARY SEAL VENT	—	—	—	—			<input type="radio"/> LOW SEAL GAS SUPPLY PRESSURE	—	—	—
9	<input type="radio"/> INTERMEDIATE SEAL VENT	—	—	—	—			<input type="radio"/> HIGH PRIMARY SEAL VENT PRESSURE	—	—	—
10	<input type="radio"/> BACK-UP SEAL VENT	—	—	—	—			<input type="radio"/> LOW BUFFER GAS SUPPLY PRESSURE	—	—	—
11	<input type="radio"/> _____	—	—	—	—			<input type="radio"/> LOW SEPARATION GAS SUPPLY PRESS.	—	—	—
12	<input type="radio"/> _____	—	—	—	—			<input type="radio"/> HIGH ΔP SEAL GAS SUPPLY FILTER	—	—	—
13	DIFFERENTIAL PRESSURE							<input type="radio"/> HIGH ΔP SEAL GAS TO COMPRESSOR	—	—	—
14	<input type="radio"/> SEAL GAS SUPPLY FILTER	—	—	—	—			<input type="radio"/> HIGH SEAL GAS SUPPLY TEMP.	—	—	—
15	<input type="radio"/> SEAL GAS TO COMPRESSOR	—	—	—	—			<input type="radio"/> HIGH BUFFER GAS SUPPLY TEMP.	—	—	—
16	<input type="radio"/> SEAL GAS SUPPLY DIFF. CONTROL	—	—	—	—			<input type="radio"/> HIGH FLOW SEAL GAS SUPPLY	—	—	—
17	<input type="radio"/> _____	—	—	—	—			<input type="radio"/> HIGH FLOW PRIMARY SEAL VENT	—	—	—
18	<input type="radio"/> _____	—	—	—	—			<input type="radio"/> HIGH FLOW INTERMEDIATE SEAL VENT	—	—	—
19	PRESSURE RELIEF							<input type="radio"/> GAS DETECTION BACK-UP SEAL VENT	—	—	—
20	<input type="radio"/> SEAL GAS SUPPLY TO FILTER	—	—	—	—			<input type="radio"/> UNIT SHUTDOWN	—	—	—
21	<input type="radio"/> PRIMARY SEAL VENT	—	—	—	—			<input type="radio"/> LOW NITROGEN SUPPLY PURITY	—	—	—
22	<input type="radio"/> INTERMEDIATE SEAL VENT	—	—	—	—			<input type="radio"/> _____	—	—	—
23	<input type="radio"/> _____	—	—	—	—			<input type="radio"/> _____	—	—	—
24	<input type="radio"/> _____	—	—	—	—			<input type="radio"/> _____	—	—	—
25	TEMPERATURE							<input type="radio"/> _____	—	—	—
26	<input type="radio"/> SEAL GAS SUPPLY	—	—	—	—			<input type="radio"/> _____	—	—	—
27	<input type="radio"/> BUFFER GAS SUPPLY	—	—	—	—			<input type="radio"/> _____	—	—	—
28	<input type="radio"/> _____	—	—	—	—						
29	<input type="radio"/> _____	—	—	—	—						
30	MISCELLANEOUS										
31	<input type="radio"/> FLOW INDICATOR SEAL GAS SUPPLY	—	—	—	—						
32	<input type="radio"/> FLOW INDICATOR BUFFER GAS SUPPLY	—	—	—	—						
33	<input type="radio"/> FLOW INDICATOR SEPARATION GAS	—	—	—	—						
34	<input type="radio"/> FLOW INDICATOR PRIMARY SEAL VENT	—	—	—	—						
35	<input type="radio"/> FLOW INDICATOR INTER. SEAL VENT	—	—	—	—						
36	<input type="radio"/> GAS DETECTION BACK-UP SEAL VENT	—	—	—	—						
37	<input type="radio"/> NITROGEN SUPPLY PURITY ANALYSER	—	—	—	—						
38	<input type="radio"/> _____	—	—	—	—						
39	<input type="radio"/> _____	—	—	—	—						
40	<input type="radio"/> _____	—	—	—	—						
41	<input type="radio"/> _____	—	—	—	—						
42	<input type="radio"/> _____	—	—	—	—						
43	<input type="radio"/> _____	—	—	—	—						
44	REMARKS										
45	_____										
46	_____										
47	_____										
48	_____										
49	_____										
50	_____										

CENTRIFUGAL COMPRESSOR DATA SHEETS (US customary units)

ENQUIRY/ORDER NO.				ITEM NO.			
JOB NO.							
REVISION	BY	DATE	CH'KD	DATE	APP'D	DATE	

1 **SELF ACTING GAS SEAL (4.8.2.5)**

2 SEAL MFR. _____ MODEL _____

3 SERIAL NO. _____

4 Gas ANALYSIS SEAL GAS _____

5 BUFFER GAS _____

6 SEPARATION GAS _____

7 **SEAL CONFIGURATION**

8 SINGLE DOUBLE TANDEM TRIPLE OTHER _____

9 SEPARATION FROM OIL SYSTEM BY: CARBON RING LABYRINTHS

10 SEPARATION GAS _____ OTHER _____

11 **SEAL OPERATING CONDITIONS**

12 OPERATING CASE

	NORMAL	MAX RATED	START-UP	SETTLE OUT
13 <input type="checkbox"/> PRIMARY SEAL PRESSURE (PSI)				
14 <input type="checkbox"/> INTERMEDIATE SEAL PRESSURE (PSI)				
15 <input type="checkbox"/> SEAL GAS INLET TEMPERATURE (°F)				
16 <input type="radio"/> PRIMARY SEAL BACK PRESSURE (PSI)				
17 <input type="radio"/> INTERMEDIATE SEAL BACK PRESSURE (PSI)				
18 <input type="radio"/> BACK-UP SEAL BACK PRESSURE (PSI)				
19 <input type="radio"/> DEPRESSURISATION TIME (min) _____				

* PROCESS UPSET CONDITION

20

21 SLOW ROLL REQUIRED: YES/NO SPEED (RPM) _____ DURATION (min) _____

22 BARRING DEVICE: YES/NO METHOD _____

23 REVERSE ROTATION CAPABILITY REQUIRED: YES/NO SPEED (RPM) _____ DURATION (min) _____

24 AT SEALING PRESSURES (PSI) PRIMARY _____ INTERMEDIATE _____ BACK-UP _____

25 MAX. PERIPHERAL SPEED AT MAX. CONT. SPEED (FPS) _____ OUTER SEAL FACE DIAMETER (IN) _____

26 **MATERIALS OF CONSTRUCTION**

27 FACE _____ SLEEVES _____

28 SEAT _____

29 ELASTOMERS _____ SCREWS _____

30 HOUSING _____ SPRINGS _____

31 LABYRINTHS _____ NACE REQUIREMENTS _____

32

33 **GAS REQUIREMENTS**

34 (ALL DATA PER SEAL)

	NORMAL OPERATION			ON SEAL FAILURE (ALL GAS SEAL ELEMENTS)
	RUNNING	START-UP	SETTLE OUT	
35 SEAL GAS				
36 TYPE				
37 PRESSURE, MIN/MAX. (PSI)				
38 TEMPERATURE, MIN/MAX. (°F)				
39 FLOW, NORMAL/MAX. *(LB/MIN)	*		*	
40 BUFFER GAS				
41 TYPE				
42 PRESSURE, MIN/MAX. (PSI)				
43 TEMPERATURE, MIN/MAX. (°F)				
44 FLOW, NORMAL/MAX. *(LB/MIN)	*		*	
45 SEPARATION GAS				
46 TYPE				
47 PRESSURE, MIN/MAX. (PSI)				
48 TEMPERATURE, MIN/MAX. (°F)				
49 FLOW, NORMAL/MAX. *(LB/MIN)	*		*	
50 * MAX. TO BE GUARANTEED				

CENTRIFUGAL COMPRESSOR DATA SHEETS (US customary units)

ENQUIRY/ORDER NO.				ITEM NO.			
JOB NO.							
REVISION	BY	DATE	CH'KD	DATE	APP'D	DATE	

1 **SELF ACTING GAS SEAL (CONT.) (4.8.2.5)**

2 **TESTING**

3 ROTATING FACE OVERSPEED TO _____ % FOR _____ MIN

4 BALANCE OF ROTATING COMPONENTS TO _____ TEST GAS _____

TEST	STATIC		DYNAMIC		STATIC		REVERSE
	DE	NDE	DE	NDE	DE	NDE	
5 GAS PRESSURES (PSI) PRIMARY							
6 INTERMEDIATE							
7 BACK-UP							
8 GAS TEMPERATURES (°F)							
9 SEAL SPEED (rpm)							
10 SEAL BACK PRESSURES (PSI) PRIMARY							
11 INTERMEDIATE							
12 BACK-UP							
13 DURATION (min)							
14 LEAKAGE LIMITS (LB/MIN)							
15 PRIMARY (LB/MIN)							
16 INTERMEDIATE (LB/MIN)							
17 BACK-UP (LB/MIN)							

18 SEAL STRIP AFTER TEST (AND RETEST) YES/NO, REQUIREMENTS _____ * IF SPECIFIED

19 **AT COMPRESSOR MANUFACTURERS CONTRACT SEALS FITTED DURING:-**

	SPEED (r/min)	GAS TYPE	PRESSURE (bar)	TEMPERATURE (°C)
20 <input type="radio"/> PERFORMANCE TEST @				
21 <input type="radio"/> MECHANICAL RUNNING TEST @				
22 <input type="radio"/> MECHANICAL STRING TEST @				
23 <input type="radio"/> GAS LEAKAGE TEST @				
24 <input type="radio"/> SETTLE-OUT PRESSURE TEST @	ZERO			

25 **OPTIONAL TESTS**

26 _____

27 _____

28 _____

29 _____

30 _____

31 _____

32 _____

33 _____

34 _____

35 _____

36 _____

37 _____

38 _____

39 _____

40 _____

41 _____

42 _____

43 _____

44 _____

45 _____

46 _____

47 _____

48 _____

49 _____

50 _____

Annex B (informative)

Material specifications for major component parts

Table B.1 — Typical specifications for major component parts

Part	Material ^a	Specification	Form	Temperature Limits ^c			
				Minimum		Maximum	
				°C	(°F)	°C	(°F)
Cast casings	Cast iron	ASTM A 278, Class 30	Cast	-45	(-50)	230	(450)
		ASTM A 278, Class 40	Cast	-30	(-20)	260	(500)
	Austenitic cast iron	ASTM A 436, Type 2	Cast	-45	(-50)	260	(500)
		ASTM A 571, Type D-2M Classes 1 & 2	Cast	-195	(-320)	260	(500)
	Ductile iron	ASTM A 395	Cast	-30	(-20)	260	(500)
	Cast steel	ASTM A 216, Grade WCB	Cast	-30	(-20)	400	(750)
		ASTM A 352, Grade LCB	Cast	-45	(-50)	345	(650)
		ASTM A 352, Grade LC2	Cast	-75	(-100)	345	(650)
		ASTM A 352, Grade LC3	Cast	-100	(-150)	345	(650)
		ASTM A 352, Grade LC4	Cast	-115	(-175)	345	(650)
		ASTM A 217	Cast	-30	(-20)	400	(750)
	Cast stainless steel	ASTM A 743, ASTM A 744 or ASTM A 351, Grades CF3	Cast	-195	(-320)	345	(650)
		CF3M, CF8 or CF 8M					
	Cast titanium	ASTM B 367, Grades C3 or C4	Cast	-45	(-50)	150	(300)
Fabricated casings	Steel	ASTM A 285, Grade C	Plate	-45	(-50)	345	(650)
		ASTM A 516, Grade 55, 60, 65, 70	Plate	-45	(-50)	345	(650)
		ASTM A 203, Grade A or B	Plate	-60	(-75)	345	(650)
		ASTM A 203, Grade D or E	Plate	-105	(-160)	345	(650)
		ASTM A 537, Class 1 or 2	Plate	-60	(-75)	345	(650)
		ASTM A 353	Plate	-195	(-320)	345	(650)
		ASTM A 553, Type I	Plate	-195	(-320)	345	(650)
		ASTM A 553, Type II	Plate	-170	(-275)	345	(650)
		ASTM A 266, Class 1 or 4	Forged	-30	(-20)	345	(650)
		ASTM A 336, Class F1	Forged	-30	(-20)	345	(650)
		ASTM A 414	Sheet	-30	(-20)	345	(650)
		ASTM A 508, Class 5a	Forged	-30	(-20)	345	(650)
	Stainless steel	ASTM A 240, Type 304, 304L, 316, 316L or 321	Plate	-195	(-320)	345	(650)

Table B.1 (continued)

Part	Material ^a	Specification	Form	Temperature Limits ^c			
				Minimum		Maximum	
			°C	(°F)	°C	(°F)	
Diaphragms and guide vanes	Cast iron	ASTM A 48 or ASTM A 278, Class 30	Cast	-195	(-320)	345	(650)
	Ductile iron	ASTM A 536	Cast	-195	(-320)	345	(650)
	Cast steel	ASTM A 216, Grade WCB	Cast	-195	(-320)	345	(650)
	Steel	ASTM A 283, ASTM A 285, ASTM A 516 or ASTM A 543	Plate	-195	(-320)	345	(650)
	Stainless steel	ASTM A 743, ASTM A 744 or ASTM A 351, Grades	Cast	-195	(-320)	345	(650)
		CA15, CF3, CF3M, CF8 or CF8M					
	Aluminium	ASTM B 26, Alloy 355 or C355	Cast	-195	(-320)	150	300
Shaft	Steel	ASTM A 470, Class 1	Forged	-30	(-20)	345	(650)
		ASTM A 470, Class 7	Forged	-115	(-175)	400	(750)
		AISI Types 1040 to 1050 ^b	Bar or forged	-30	(-20)	345	(650)
		AISI Types 4140 to 4150 ^b	Bar or forged	-30	(-20)	400	(750)
		AISI Types 4340 to 4345 ^b	Bar or forged	115	(-175)	425	(800)
		AISI Types 2320 ^b	Bar or forged	-110	(-170)	345	(650)
		ASTM A 522, Type 1	Forged	-195	(-320)	345	(650)
	Stainless steel	ASTM A 336, Grade F6	Forged	-60	(-75)	345	(650)
		ASTM A 473, Type 410	Forged	-60	(-75)	345	(650)
	Precipitation hardening stainless steel	ASTM A 705, Types 630 or XM-12	Forged	-75	(-100)	345	(650)
Cast impellers	Aluminum	ASTM B 26, Alloy C355	Cast	-195	(-320)	150	(300)
	Precipitation hardening stainless steel	ASTM A 747, Types CB7CU-1 or CBCU-2	Cast	-75	(-100)	345	(650)
	Steel	ASTM A 148	Cast	-30	(-20)	345	(650)
		ASTM A 487 Gs 4Q	Cast	-45	(-50)	345	(650)
	Stainless steel	ASTM A 743, ASTM A 744 or ASTM A 351, Grade	Cast	-45	(-50)	345	(650)
		CA15 or CA6NM					
		ASTM A 743, ASTM A 744 or ASTM A 351, Grade	Cast	-195	(-320)	345	(650)

Table B.1 (continued)

Part	Material ^a	Specification	Form	Temperature Limits ^c				
				Minimum		Maximum		
				°C	(°F)	°C	(°F)	
		CF3, CFM, CF8, CF8M						
	Titanium	ASTM B 367, Grade C3 or C4	Cast	-45	(-50)	345	(650)	
Fabricated impellers (covers, hubs blades)	Steel	AISI Types 4130-4140 ^b	Plate or forged	-30	(-20)	400	(750)	
		AISI Types 4320-4345 ^b	Plate or forged	-115	(-175)	400	(750)	
		AISI Type 3140 ^b	Forged	-45	(-50)	400	(750)	
			ASTM A 543	Plate	-115	(-175)	400	(750)
			ASTM A 522, Type I	Forged	-145	(-230)	345	(650)
			ASTM A 522, Type II	Forged	-170	(-275)	345	(650)
			ASTM A 353 or ASTM A 583, Type I	Plate	-195	(-320)	345	(650)
			AISI Type 403 ^b	Forged	-60	(-75)	345	(650)
			ASTM A 473, Type 410	Forged	-60	(-75)	345	(650)
			ASTM A 240, Type 304, 304L, 316, 316L	Plate	-195	(-320)	345	(650)
		ASTM A 473, Type 304, 304L, 316, 316L	Forged	-195	(-320)	345	(650)	
	Precipitation hardening stainless steel	ASTM A 705, Types 630 or XM-12	Forged	-75	(-100)	345	(650)	
		ASTM A 693, Types 630 or XM-12	Plate	-75	(-100)	345	(650)	
	Ni-Cu alloy	SAE AMS 4646	Forged	-115	(-175)	345	(650)	
		ASTM B 127	Plate	-115	(-175)	345	(650)	
		QQ-N-286	Plate	-115	(-175)	345	(650)	
Labyrinths								
Impeller interstage shaft seal and balance piston	Aluminum	ASTM B 26, Alloys 443, 335, 850, A850, B850	Cast	-195	(-320)	315	(600)	
		6061-T6 or 1100	Plate	-195	(-320)	315	(600)	
	Babbitt	ASTM B 23	Cast	-195	(-320)	175	(350)	
	Stainless steel	AISI Type 403, 410, 416, 303, 304 or 316 ^b	Wrought	-195	(-320)	345	(650)	
	Cr-Ni-Fe-Mo-Cu-Cb Alloy	ASTM B 462	Wrought	-195	(-320)	345	(650)	
	Stainless steel honeycomb	ASTM A 240, Types 304, 304L, 316 or 316L	Fabricated	-195	(-320)	345	(650)	
	Ni-Cu alloy	ASTM B 164	Wrought	-115	(-175)	345	(650)	
	Nonmetallic TFE ^d		Molded	-195	(-320)	260	(500)	

Table B.1 (continued)

Part	Material ^a	Specification	Form	Temperature Limits ^c			
				Minimum		Maximum	
			°C	(°F)	°C	(°F)	
	Nonmetallic TFE ^d carbon-filled		Molded	-30	(-20)	260	(500)
	Nonmetallic TFE ^d mica-filled		Molded	-55	(-65)	260	(500)
	Lead	ASTM B 29	Cast	-100	(-150)	205	(400)
Balance	Steel	ASTM A 470, Class 1	Forged	-30	(-20)	345	(650)
piston		ASTM A 470, Class 7	Forged	-115	(-175)	400	(750)
		AISI Types 1040 to 1050 ^b	Forged	-30	(-20)	345	(650)
		AISI Types 4130 to 4145 ^b	Forged	-30	(-20)	400	(750)
		AISI Types 4330, 4345 ^b	Forged	-115	(-175)	455	(850)
		AISI Type 2320 ^b	Forged	-110	(-170)	345	(650)
		ASTM A 522, Type 1	Forged	-195	(-320)	345	(650)
	Stainless steel	ASTM A 336, Grade F6	Forged	-60	(-75)	345	(650)
		ASTM A 473, Type 410	Forged	-60	(-75)	345	(650)
		AISI Type 403 or 410 ^b	Forged	-30	(-20)	345	(650)
	Precipitation hardening stainless steel	ASTM A 705, Types 630 or XM-12	Forged	-75	(-100)	345	(650)
	Ni-Cu-alloy	SAE AMS 4676	Forged	-115	(-175)	345	(650)
Shaft sleeves	Steel	AISI Types 4130 to 4150 ^b	Forged	-45	(-50)	345	(650)
		AISI Types 4320 to 4345 ^b	Forged	-115	(-175)	400	(750)
		ASTM A 470, Class 7	Forged	-115	(-175)	400	(750)
		ASTM A 522, Type I	Forged	-195	(-320)	345	(650)
	Stainless steel	AISI Types 403 or 410 ^b	Forged	-75	(-100)	400	(750)
	Ni-Cu alloy	ASTM B 164 or SAE AMS 4676	Forged	-115	(-175)	345	(650)
	Ni-Mo-Cr alloy	ASTM B 574, Alloy N10276	Wrought	-115	(-175)	345	(650)
		ASTM A 494, Grade CW-12M-1	Cast	-115	(-175)	345	(650)

Table B.1 (continued)

Part	Material ^a	Specification	Form	Temperature Limits ^c			
				Minimum		Maximum	
				°C	(°F)	°C	(°F)
	Precipitation hardening stainless steel	ASTM A 705 Type 630 or XM-12	Forged	-75	(-100)	345	(650)
<p>^a The materials shown on this table are those commonly used by compressor manufacturers, but the list is not all inclusive. Other suitable materials may exist and may be used by compressor manufacturers as indicated by specific design considerations (4.11.1.1).</p> <p>^b Descriptions of AISI types can be found in publication ASTM DS 56E. AISI designations are only a description of chemical analyses of types of steel, they are not procurement specifications. All materials should be purchased to a specification which adequately defines the required properties and controls.</p> <p>^c The temperature limits shown in this table are those commonly observed by compressor manufacturers and are not necessarily the same as any temperature limits specified in the applicable material specifications.</p> <p>^d TFE = tetrafluorethylene.</p>							

STANDARDSISO.COM : Click to view the full PDF of ISO 10439:2002

Annex C (normative)

Centrifugal compressor vendor drawing and data requirements

C.1 A certified dimensional outline drawing and a list of connections is required, which shall include the following:

- a) size, rating and location of all customer connections;
- b) approximate overall handling weights;
- c) overall dimensions;
- d) shaft centreline height;
- e) dimensions of base plates (if furnished), complete with diameter, number and locations of bolt holes and thickness of the metal through which the bolts must pass, centres of gravity and details for foundation design;
- f) the weight and center of gravity of the machine, of the heaviest piece of equipment that must be handled for erection, and of significant items to be handled for maintenance;
- g) principal dimensions, including those required for the piping design, maintenance clearances, and dismantling clearances, and the maximum loading limit on the main process flanges (both forces and moments);
- h) the direction of rotation of each drive train component;
- i) the size, type, location and identification of all the purchaser's connections, including vents, drains, lubricating oil, conduits and instruments (the vendor's plugged connections shall be identified);
- j) if couplings are furnished, their make, size, and type and the style of the coupling guards;
- k) a list of reference drawings;
- l) a list of special weather protection and climatization features;
- m) cold alignment setting data for equipment furnished by the vendor which shall include a composite diagram or data on expected thermal growth, including transient effects, shall be included;
- n) completed information to permit adequate foundation design by the purchaser, which shall include but not be limited to
 - 1) grouting details,
 - 2) size and location of foundation on bolts, and
 - 3) weight distribution for each bolt/sub-sole plate location;
- o) the location of the center of gravity and rigging provisions to permit removal of the top half of the casing, the rotor, and any subassemblies with a mass of more than 100 kg (250 lb);
- p) equipment furnished by the vendor for mounting by the purchaser.

C.2 A cross-sectional drawing and bill of materials is required, which shall include the following:

- a) journal-bearing clearances and tolerances;

- b) axial rotor float for all rotors (compressor, gas generator, power turbine);
- c) shaft end and internal labyrinth seal clearances and tolerances;
- d) axial position of rotor disks, blades relative to inlet nozzles or vanes, tolerances allowed;
- e) outside diameter of all disks (impellers) at the blade tip.

C.3 Rotor assembly drawings and bills of materials are required, which shall include the following:

- a) axial position from the active thrust-collar face to
 - 1) each impeller or rotating disc, inlet side,
 - 2) each radial probe,
 - 3) each journal-bearing centreline,
 - 4) phase-angle notch, and
 - 5) coupling face or end of shaft;
- b) thrust-collar assembly details, including
 - 1) collar-shaft with tolerance,
 - 2) concentricity (or axial runout) tolerance,
 - 3) required torque,
 - 4) surface finish requirements for collar faces, and
 - 5) preheat method and temperature requirements for shrunk-on collar installation;
- c) dimensioned shaft ends for coupling mountings.

C.4 A thrust-bearing assembly drawing and a bill of material shall be provided.

C.5 Journal-bearing assembly drawings and bills of materials for all field-maintainable rotors shall be provided.

C.6 Shaft coupling assembly drawings and bills of materials are required, which shall include the following:

- a) hydraulic mounting procedure;
- b) shaft end gap and tolerance;
- c) coupling guards;
- d) thermal growth from a baseline of 15 °C (60 °F).

C.7 A seal and seal system schematic are required, which include the following:

- a) steady-state and transient fluid flows and pressures;
- b) control, alarm, and trip settings;
- c) heat loads;
- d) utility requirements, including electrical, water, air and nitrogen;

ISO 10439:2002(E)

- e) pipe and valve sizes;
- f) bill of materials.

C.8 Seal and seal system assembly and arrangement drawings, including size, rating and location of all customer connections, shall be provided.

C.9 Seal and seal system component drawings and data are required, which shall include the following, as applicable:

- a) pumps and drivers or seal gas equipment, including
 - 1) certified dimensional outline drawings,
 - 2) cross-section and bill of material,
 - 3) mechanical seal drawing and bill of materials (pumps and drivers),
 - 4) list of recommended spare parts,
 - 5) instruction and operating manuals, and
 - 6) completed data sheets;
- b) overhead tank, reservoir, and drain tanks, including
 - 1) fabrication drawings,
 - 2) maximum, minimum and normal liquid levels, and
 - 3) completed data sheets;
- c) coolers, filters, accumulators and other seal system components, including
 - 1) fabrication drawings,
 - 2) spare parts, and
 - 3) data sheets;
- d) instrumentation, including
 - 1) switches,
 - 2) control valves, and
 - 3) gauges.

C.10 A "lube" oil/control oil schematic and bills of materials are required, which shall include the following:

- a) steady-state and transient oil flows and pressures to each use point;
- b) control, alarm and trip settings (pressures and recommended temperatures);
- c) heat loads at each use point at maximum load;
- d) utility requirements, including electricity, water and air;
- e) pipe and valves sizes;

f) instrumentation, safety devices and control schemes.

C.11 "Lube" oil assembly and arrangement drawings, including size, rating and location of all customer connections, shall be provided.

C.12 "Lube" oil component drawings and data shall be provided.

C.13 Electrical and instrumentation schematics and bills of materials for all systems shall be provided. The schematics shall show all alarms and shutdown limits (set points).

C.14 An electrical and instrumentation arrangement drawing and list of connections shall be carried out.

C.15 Tabulation of utility requirements shall be carried out.

C.16 Curves shall be furnished showing polytropic head and polytropic efficiency versus inlet volume flow curves for each section or casing on multiple-section or multiple-casing units, in addition to composite curves at 80 %, 90 %, 100 % and 105 % of rated speed.

C.17 Curves shall be furnished showing discharge pressure and shaft power versus inlet volume flow at rated conditions for each section or casing on multiple-section or multiple-casing units, in addition to composite curves of 80 %, 90 %, 100 % and 105 % of rated speed. For service with gases of varying molecular mass (M), curves shall also be furnished at maximum and minimum M. For air compressors, curves shall also be furnished at three additional specified inlet temperatures.

C.18 A curve shall be furnished showing the pressure above inlet pressure behind the balance drum versus unit loading of the thrust shoes, both in kilopascals (psi), using rated conditions as the curve basis. The curve shall extend from a pressure equal to inlet pressure behind the drum to a pressure corresponding to at least 3 500 kPa (500 psi) unit loading on the thrust shoes. Balance drum outer diameter, effective balance drum area, and expected and recommended maximum allowable pressure behind the balance drum shall be shown on the curve sheet.

C.19 A speed-versus-starting-torque curve shall be given. A speed-versus-torque curve for the compressor, superimposed over the motor-speed-versus-torque starting curve and with the motor values based on the specified starting voltage shall also be provided.

C.20 Vibration analysis data, is required, which shall include, the following:

- a) number of vanes — each impeller;
- b) number of vanes — each guide vane.

C.21 A lateral critical analysis report is required, which shall include, but is not limited to, the following:

- a) complete description of the method used;
- b) graphic display of critical speeds versus operating speeds;
- c) graphic display of bearing and support stiffness and its effect on critical speeds;
- d) damped unbalanced response analysis (see 4.9.2.4);
- e) journal static loads;
- f) stiffness and damping coefficients;
- g) tilting-pad bearing geometry and configuration, including:
 - 1) pad angle (arc) and number of pads,
 - 2) pivot offset,

- 3) pad clearance (with journal radius, pad bore radius, and bearing-set bore radius), and
- 4) preload.

C.22 Torsional critical analysis report shall be provided, which shall include, but is not limited, to the following:

- a) complete description of the method used;
- b) graphic display of the mass elastic system;
- c) tabulation identifying the mass moment and torsional stiffness of each component identified in the mass elastic system;
- d) graphic display of exciting forces versus speed and frequency;
- e) graphic display of torsional critical speeds and deflections (mode-shape diagram);
- f) effects of alternative coupling on analysis (if required).

C.23 A transient torsional analysis for all synchronous motor driven units shall be provided.

C.24 The allowable flange loading for all customer's casing connections, including anticipated thermal movements referenced to a defined point, shall be given.

C.25 An alignment diagram, including recommended coupling limits during operation shall be provided. All shaft-end position changes and support growth from a reference ambient temperature of 15 °C (60 °F), or another temperature specified by the purchaser, shall be shown. Include the recommended alignment method and cold setting targets.

C.26 Welding procedures for fabrication and repair shall be given.

C.27 Certified hydrostatic test logs shall be given.

C.28 Mechanical running test logs shall be provided, including, but not limited to, the following:

- a) oil flows, pressures, and temperatures;
- b) vibration, including an x - y plot of amplitude and phase angle versus revolutions per minute during start-up and coast-down;
- c) bearing metal temperatures;
- d) observed critical speeds (for flexible rotors);
- e) if specified, tape recording of real-time vibration data.

C.29 Performance test logs and report in accordance with ISO 5389 or ASME PTC 10 shall be provided.

C.30 Non-destructive test procedures, as itemized on the purchase order data sheets or the vendor drawing and data requirements form, shall be given.

C.31 Procedures for any special or optional tests (see 6.3.6) shall be given.

C.32 Certified mill test reports of items, as agreed upon shall be given.

C.33 Rotor balancing logs, including a residual unbalance report in accordance with annex D, shall be provided.

C.34 Rotor combined mechanical and electrical runout in accordance with 4.9.5.7 shall be given.

C.35 As-built data sheets shall be provided.

C.36 As-built dimensions (including nominal dimensions with design tolerances) and data shall be provided for the following listed parts:

- a) shaft or sleeve diameters at
 - 1) thrust collar (for separate collars),
 - 2) each seal component,
 - 3) each wheel (for stacked rotors) or bladed disk,
 - 4) each interstage labyrinth, and
 - 5) each journal bearing;
- b) each wheel or disk bore (for stacked rotors) and outside diameter;
- c) each labyrinth or seal-ring bore;
- d) thrust-collar bore (for separate collars);
- e) each journal-bearing inside diameter;
- f) thrust-bearing concentricity (axial runout);
- g) metallurgy and heat treatment for
 - 1) shaft,
 - 2) impellers or bladed disks,
 - 3) thrust collar, and
 - 4) blades, vanes and nozzles.

C.37 An installation manual shall be provided describing the following (see 7.3.6.2):

- a) storage procedures,
- b) foundation plan,
- c) grouting details,
- d) setting equipment, rigging procedures, component masses and lifting diagrams,
- e) coupling alignment diagram (per C.25),
- f) piping recommendations, including allowable flange loads,
- g) composite outline drawings for the driver/driven-equipment train, including anchor-bolt locations, and
- h) dismantling clearances.

C.38 Operating and maintenance manuals shall be provided describing:

- a) start-up;

- b) normal shutdown;
- c) emergency shutdown;
- d) list of undesirable speeds (see 4.9.1.7);
- e) lube-oil recommendations;
- f) routine operational procedures, including recommended inspection schedules and procedures;
- g) instructions for
 - 1) disassembly and reassembly of rotor in casing,
 - 2) rotor unstacking and restacking procedures,
 - 3) disassembly and reassembly of journal bearings (for tilting-pad bearings, the instruction shall include "go/no go" dimensions with tolerances for three-step plug gauges),
 - 4) disassembly and reassembly of thrust bearing,
 - 5) disassembly and reassembly of seals (including maximum and minimum clearances), and
 - 6) disassembly and reassembly of thrust collar;
- h) performance data, including
 - 1) polytropic head and polytropic efficiency versus inlet volume flow,
 - 2) discharge pressure and shaft power versus inlet volume flow,
 - 3) balance drum differential pressure versus thrust loading, and
 - 4) speed versus starting torque;
- i) vibration analysis data, per C.20 to C.23;
- j) as-built data, including
 - 1) as-built data sheets,
 - 2) as-built dimensions or data, including assembly clearances,
 - 3) hydrostatic test logs, per C.27,
 - 4) mechanical running test logs, per C.28,
 - 5) rotor balancing logs, per C.33, and
 - 6) rotor mechanical and electrical runout at each journal, per C.34;
- k) drawings and data, including
 - 1) certified dimensional outline drawing and list of connections,
 - 2) cross-sectional drawings and bills of materials,
 - 3) rotor assembly drawings and bills of materials,

- 4) thrust-bearing assembly drawings and bills of materials,
 - 5) journal-bearing assembly drawings and bills of materials,
 - 6) seal component drawings and bills of materials,
 - 7) "lube" oil schematic and bills of materials,
 - 8) "lube" oil assembly drawing and list of connections,
 - 9) "lube" oil component drawings and data,
 - 10) electrical and instrumentation schematics and bills of materials, and
 - 11) electrical and instrumentation assembly drawings and list of connections;
- l) maintenance information, comprising
- 1) maximum and minimum bearing, labyrinth, and seal clearances,
 - 2) instructions for measuring and adjusting cold clearances,
 - 3) rotor float allowance,
 - 4) interference fits on parts that are required to be removed or replaced for maintenance or normally consumable spares,
 - 5) runout and concentricity tolerances on parts of assembled rotors, and
 - 6) balancing tolerances;
- m) reassembly information, comprising
- 1) bolting sequence and torque values for such items as casing, bolting and internal bolting,
 - 2) reassembly sequences together with required inspection checks,
 - 3) adjustment procedures to achieve required positions, clearances and float,
 - 4) detailed procedures for proportional checks, including settings and adjustments, and
 - 5) coupling installation procedures.

C.39 The following spare-parts recommendations shall be included:

- a) pattern, stock or production numbers and materials or construction;
- b) identification of original equipment manufacturer of each part to determine interchangeability.

C.40 Progress reports and delivery schedule, including vendor buy-outs and milestones, shall be provided.

C.41 A list of drawings, including latest revision numbers and dates, shall be provided.

C.42 Shipping lists, including all major components that shall be shipped separately and the preservation, package and shipping procedure, shall be provided.

C.43 A list of special tools furnished for maintenance (see 5.6), shall be provided.

C.44 A technical data manual shall be provided, which shall include the following:

- a) as-built purchaser's data sheets, per C.35;
- b) certified performance curves, per C.17 and C.18;
- c) drawings in accordance with 7.3.2;
- d) as-built assembly clearances;
- e) spare parts lists, in accordance with 7.3.5;
- f) utility data, per C.15;
- g) vibration data, C.20;
- h) reports and data, per C.21, C.22, C.23, C.25, C.28, C.29, C.33 and C.34.

C.45 Material safety data sheets (in accordance with local regulations) shall be included.

C.46 Pressure vessel fabrication data including the manufacturer's data report, rubbings of the code stamp, stress relief charts and mill test reports shall be provided.

STANDARDSISO.COM : Click to view the full PDF of ISO 10439:2002