

---

---

**Measurement of fluid flow in closed  
conduits — Velocity-area methods of flow  
measurement in swirling or asymmetric  
flow conditions in circular ducts by  
means of current-meters or Pitot static  
tubes**

*Mesurage de débit des fluides dans les conduites fermées — Mesurage  
de débit dans les conduites circulaires dans le cas d'un écoulement  
giratoire ou dissymétrique par exploration du champ des vitesses au  
moyen de moulinets ou de tubes de Pitot doubles*



**PDF disclaimer**

This PDF file may contain embedded typefaces. In accordance with Adobe's licensing policy, this file may be printed or viewed but shall not be edited unless the typefaces which are embedded are licensed to and installed on the computer performing the editing. In downloading this file, parties accept therein the responsibility of not infringing Adobe's licensing policy. The ISO Central Secretariat accepts no liability in this area.

Adobe is a trademark of Adobe Systems Incorporated.

Details of the software products used to create this PDF file can be found in the General Info relative to the file; the PDF-creation parameters were optimized for printing. Every care has been taken to ensure that the file is suitable for use by ISO member bodies. In the unlikely event that a problem relating to it is found, please inform the Central Secretariat at the address given below.

STANDARDSISO.COM : Click to view the full PDF of ISO 7194:2008



**COPYRIGHT PROTECTED DOCUMENT**

© ISO 2008

All rights reserved. Unless otherwise specified, no part of this publication may be reproduced or utilized in any form or by any means, electronic or mechanical, including photocopying and microfilm, without permission in writing from either ISO at the address below or ISO's member body in the country of the requester.

ISO copyright office  
Case postale 56 • CH-1211 Geneva 20  
Tel. + 41 22 749 01 11  
Fax + 41 22 749 09 47  
E-mail [copyright@iso.org](mailto:copyright@iso.org)  
Web [www.iso.org](http://www.iso.org)

Published in Switzerland

# Contents

Page

Foreword.....	iv
Introduction .....	v
<b>1 Scope .....</b>	<b>1</b>
<b>2 Normative references .....</b>	<b>1</b>
<b>3 Symbols .....</b>	<b>2</b>
<b>4 Principle.....</b>	<b>2</b>
<b>5 Choice of measuring plane.....</b>	<b>3</b>
<b>6 Devices for improving flow conditions.....</b>	<b>3</b>
<b>7 Measurement of local velocities.....</b>	<b>7</b>
<b>8 Determination of mean flow velocity .....</b>	<b>14</b>
<b>9 Accuracy of flow-rate estimation .....</b>	<b>14</b>
<b>Annex A (normative) Detection and removal of regular pressure fluctuations.....</b>	<b>17</b>
<b>Annex B (normative) Damping of manometers.....</b>	<b>18</b>
<b>Annex C (normative) Calculation of Pitot static tube locations for method B.....</b>	<b>20</b>
<b>Annex D (normative) Corrections to be applied when a Pitot static tube is used.....</b>	<b>22</b>
<b>Annex E (normative) Corrections to be applied when a current-meter is used .....</b>	<b>23</b>
<b>Annex F (normative) Errors due to non-axisymmetrical velocity distribution .....</b>	<b>26</b>
<b>Bibliography .....</b>	<b>27</b>

## Foreword

ISO (the International Organization for Standardization) is a worldwide federation of national standards bodies (ISO member bodies). The work of preparing International Standards is normally carried out through ISO technical committees. Each member body interested in a subject for which a technical committee has been established has the right to be represented on that committee. International organizations, governmental and non-governmental, in liaison with ISO, also take part in the work. ISO collaborates closely with the International Electrotechnical Commission (IEC) on all matters of electrotechnical standardization.

International Standards are drafted in accordance with the rules given in the ISO/IEC Directives, Part 2.

The main task of technical committees is to prepare International Standards. Draft International Standards adopted by the technical committees are circulated to the member bodies for voting. Publication as an International Standard requires approval by at least 75 % of the member bodies casting a vote.

Attention is drawn to the possibility that some of the elements of this document may be the subject of patent rights. ISO shall not be held responsible for identifying any or all such patent rights.

ISO 7194 was prepared by Technical Committee ISO/TC 30, *Measurement of fluid flow in closed conduits*, Subcommittee SC 5, *Velocity and mass methods*.

This second edition results from the reinstatement of ISO 7194:1983 which was withdrawn in 2003 and with which it is technically identical.

STANDARDSISO.COM : Click to view the full PDF of ISO 7194:2008

## Introduction

In order to carry out measurements of the flow-rate of single phase fluids in closed pipes by velocity-area methods, using either current-meters or Pitot static tubes, with satisfactory accuracy (e.g. of the order of  $\pm 2\%$ ), it is usually necessary to choose a measuring plane where the velocity distribution approaches that of fully developed flow (see ISO 3354 and ISO 3966).

There are, however, some cases where it is practically impossible to obtain such a flow distribution, but where as good as possible a measurement of the flow-rate is desirable.

STANDARDSISO.COM : Click to view the full PDF of ISO 7194:2008

[STANDARDSISO.COM](http://STANDARDSISO.COM) : Click to view the full PDF of ISO 7194:2008

# Measurement of fluid flow in closed conduits — Velocity-area methods of flow measurement in swirling or asymmetric flow conditions in circular ducts by means of current-meters or Pitot static tubes

## 1 Scope

This International Standard specifies velocity-area methods for measuring flow in swirling or asymmetric flow conditions in circular ducts by means of current-meters or Pitot static tubes.

It specifies the measurements required, the precautions to be taken, the corrections to apply, and describes the additional uncertainties which are introduced when a measurement in asymmetric or swirling flow has to be made.

Only flows with a negligible radial component are considered, however. Furthermore, it is not possible to make a measurement in accordance with this International Standard if, at any point in the measuring cross-section, the local velocity makes an angle of greater than  $40^\circ$  with the axis of the duct, or where the index of asymmetry  $Y$  (defined in Annex F) is greater than 0,15.

This International Standard deals only with instruments for measuring local velocity as defined in ISO 3354 and ISO 3966. If Pitot static tubes are used, this International Standard applies only to flows where the Mach number corresponding to local velocities does not exceed 0,25.

## 2 Normative references

The following referenced documents are indispensable for the application of this document. For dated references, only the edition cited applies. For undated references, the latest edition of the referenced document (including any amendments) applies.

ISO/TR 3313, *Measurement of fluid flow in closed conduits — Guidelines on the effects of flow pulsations on flow-measurement instruments*

ISO 3354:2008, *Measurement of clean water flow in closed conduits — Velocity-area method using current-meters in full conduits and under regular flow conditions*

ISO 3455:2007, *Hydrometry — Calibration of current-meters in straight open tanks*

ISO 3966:2008, *Measurement of fluid flow in closed conduits — Velocity area method using Pitot static tubes*

ISO 4006, *Measurement of fluid flow in closed conduits — Vocabulary and symbols*

ISO 5168, *Measurement of fluid flow — Procedures for the evaluation of uncertainties*

### 3 Symbols

For the purposes of this document, the symbols given in ISO 4006, and the following, apply.

Symbol	Description	Dimension	SI unit
$D$	Pipe diameter	L	m
$d$ {	Diameter of the head of a Pitot static tube Diameter of holes or tubes of a straightener	} L	m
$E$	Uncertainty, as a relative value	—	—
$e$	Uncertainty, as an absolute value	— <sup>a</sup>	— <sup>a</sup>
$k_{\phi}$	Directional calibration coefficient	—	—
$l$	Length of the head of a Pitot static tube	L	m
$R$	Pipe radius	L	m
$r$	Measuring circle radius	L	m
$U$	Mean axial fluid velocity	LT <sup>-1</sup>	m/s
$U_i$	Mean velocity along the $i$ th radius	LT <sup>-1</sup>	m/s
$v$	Local velocity of the fluid	LT <sup>-1</sup>	m/s
$v_x$	Component of the local velocity parallel to the pipe axis	LT <sup>-1</sup>	m/s
$Y$	Index of asymmetry of the flow	—	—
$y$	Distance between the heel of a Pitot static tube and the wall	L	m
$y_1$	Distance between the nose of a Pitot static tube and the wall	L	m
$\alpha$	Calibration factor of a Pitot static tube	—	—
$\Delta p$	Differential pressure registered by a Pitot static tube	ML <sup>-1</sup> T <sup>-2</sup>	Pa
$\varepsilon$	Expansibility factor	—	—
$\theta$	Angle of the local velocity with the pipe axis	—	rad <sup>b</sup>
$\rho$	Mass density of the fluid	ML <sup>-3</sup>	kg/m <sup>3</sup>
$\phi$	Angle of the local velocity with the metering device axis	—	rad <sup>b</sup>

<sup>a</sup> The dimensions and units are those of the quantity to which the symbol refers.

<sup>b</sup> Although the radian is the SI unit, for the purposes of this International Standard, angles are expressed in degrees.

### 4 Principle

This International Standard describes

- methods which minimize the errors in carrying out a traverse in swirling or asymmetric flow;
- corrections which should be applied for certain sources of error;
- methods of determining the increase in uncertainty in the flow-rate measurement when it is not possible to compensate for a particular source of error.

The origins of the errors giving rise to the uncertainties considered in this International Standard are

- a) errors in the determination of local velocities, due to the behaviour of the instruments in a disturbed flow;
- b) errors in the calculated mean pipe velocity, due to the number and position of the measuring points and the methods of integration used.

Corrections are possible for some of these errors, but, in general, the limiting uncertainty in the flow-rate measurement has to be increased according to the characteristics of the flow.

Although velocity-area integration techniques to measure flow-rate under conditions where there is swirl and/or asymmetry in the flow are described, a measuring section in the pipe where the swirl or asymmetry is as small as possible is preferred.

## 5 Choice of measuring plane

When the configuration of the pipe and any fittings installed in it is such that any changes of directions of the flow are all in the same plane (e.g. a single bend, a single valve, or two bends in an S-shape), no significant bulk swirl is introduced and the disturbance to the flow results in an essentially asymmetric velocity distribution.

If, however, the pipe configuration is such that the flow changes direction in two or more different planes in rapid succession (e.g. two bends at 90° to each other), a bulk swirl is introduced in addition to the asymmetry which the individual fittings introduce.

Unlike asymmetry, swirl has a big effect on the response of Pitot static tubes and current-meters, and also persists for very much longer distances; whenever possible, therefore, the traverse plane should not be downstream of a swirl-inducing configuration. Care should also be taken to avoid locating the traverse plane downstream of any adjustable fitting for which the geometry may change (e.g. a flow control valve), especially if several different flow-rates have to be measured.

## 6 Devices for improving flow conditions

**6.1** Where asymmetric or swirling flow is to be measured, a device (straightener) for improving flow conditions should be used, if possible. It should be installed as shown in Figure 1.

The lengths  $L_1$ ,  $L_2$ ,  $L_3$  shall fulfil the conditions:  $L_1 \geq 3D$ ;  $L_2 \geq 5D$ ;  $L_3 \geq 2D$ .

These distances should be increased whenever possible, and, where a total straight length of more than  $10D$  exists upstream of the traverse plane, it is better to increase the distance between the pipe fitting and the straightener than to increase the distance between the straightener and the traverse plane.

**6.2** The choice of straightener is dependent on the nature of the velocity distribution which has to be corrected and on the head loss which can be tolerated. Five types of straightener are described below.

### 6.2.1 Type A — Zanker straightener (see Figure 2)

The purpose of this device is to eliminate both swirl and asymmetry. It has a head loss of approximately five velocity heads. The various plates should be chosen to provide adequate strength, but should not be unnecessarily thick.

**6.2.2 Type B — Sprenkle straightener** (see Figure 3)

The Sprenkle straightener consists of three perforated plates in series, and is particularly effective in eliminating asymmetry. It does, however, have a high head loss (about 15 velocity heads) but two plates or even one plate (with head losses of about 10 and five velocity heads, respectively) can be used if such a high head loss is not acceptable. Although they cannot completely eliminate such severe asymmetry as can the three plates, they are often sufficient for disturbances such as a single bend. Perforated plate straighteners have some effect in reducing swirl, but are not designed for this; if, therefore, swirl is the dominant type of irregularity in the velocity distribution, one of the other straighteners should be used.

**6.2.3 Type C — Tube bundle straightener** (see Figure 4)

The basic purpose of the tube bundle straightener is to eliminate swirl, but it also has some effect in reducing asymmetry. There shall be a minimum of 19 tubes, with a length of at least 20 times the diameter of the tubes, and each tube shall have a maximum diameter of  $D/5$ . The head loss of this straightener depends on the size and length of the individual tubes, but is typically about five velocity heads.

**6.2.4 Type D — AMCA straightener** (see Figure 5)

The AMCA straightener is useful only in eliminating swirl; it does not improve asymmetric velocity distributions. Its dimensions are given in Figure 5, and it has a very low head loss, normally about 0,25 times the velocity head.

**6.2.5 Type E — Étoile straightener** (see Figure 6)

The étoile straightener is again designed only to eliminate swirl, and is of no assistance with asymmetric velocity distributions. The eight radial vanes should be chosen to provide adequate strength, but should not be unnecessarily thick. This straightener should have a length equal to  $2D$ . It has a very low head loss, similar to that of the AMCA straightener, but has the advantage that it is much easier to manufacture. In addition, it allows the static pressure to equalize radially as the flow passes through it, unlike the AMCA, tube bundle or Zanker straighteners which can induce significant variation in static pressure across the pipe downstream of them.

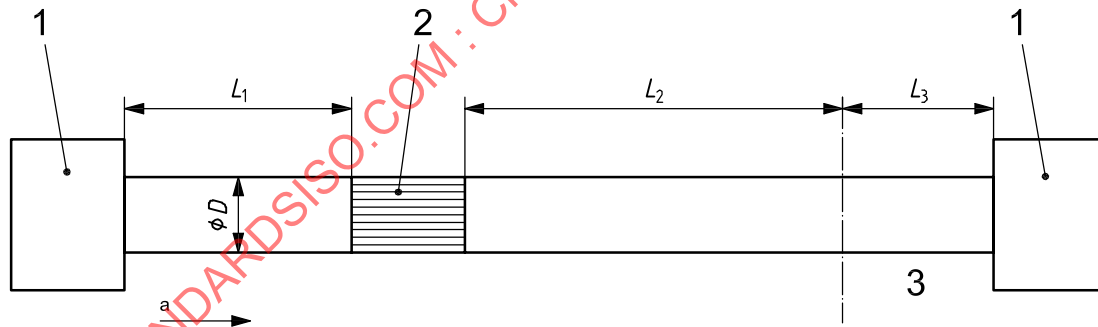

- Key**
- 1 any pipe fitting
  - 2 straightener
  - 3 measuring section
  - a Flow.

**Figure 1 — Installation of straightener**

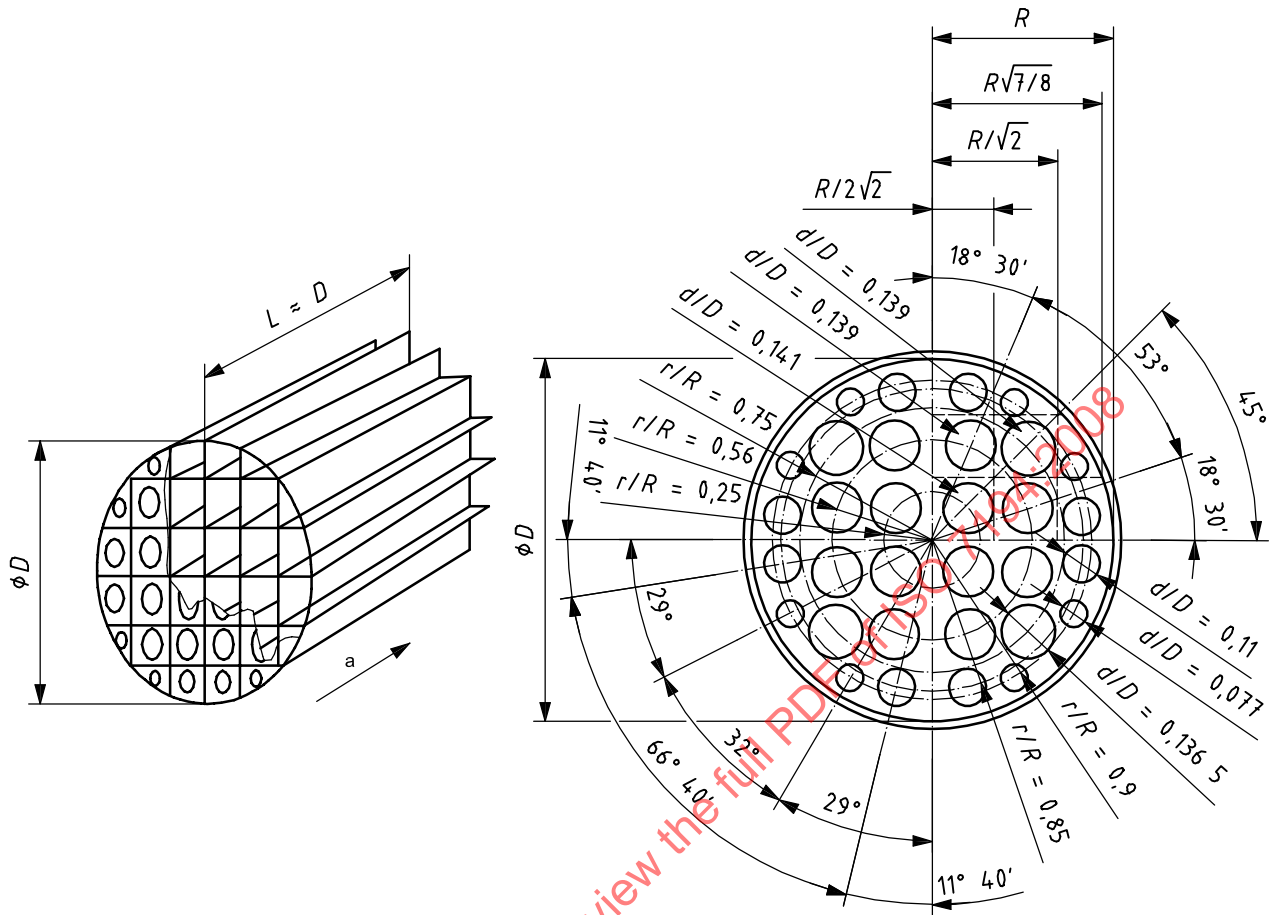

a Flow.

Figure 2 — Type A — Zanker straightener

STANDARDSISO.COM. Click to view the full PDF file (ISO 7194:2008)

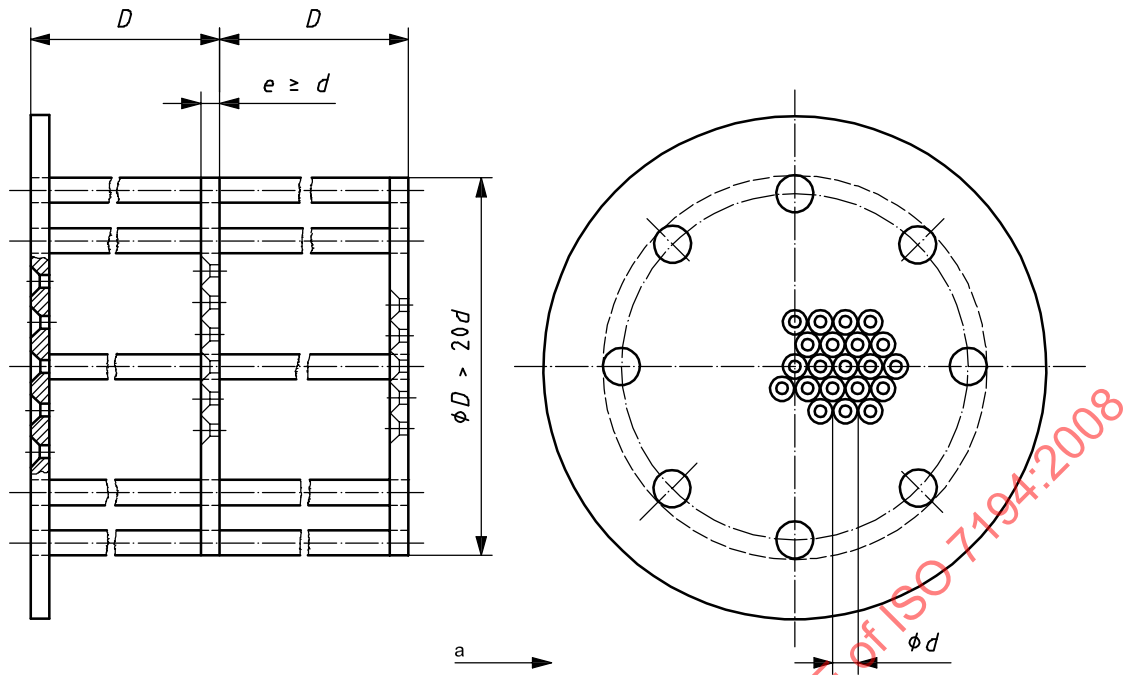

a Flow direction.

Figure 3 — Type B — Sprengle straightener (perforated plates)

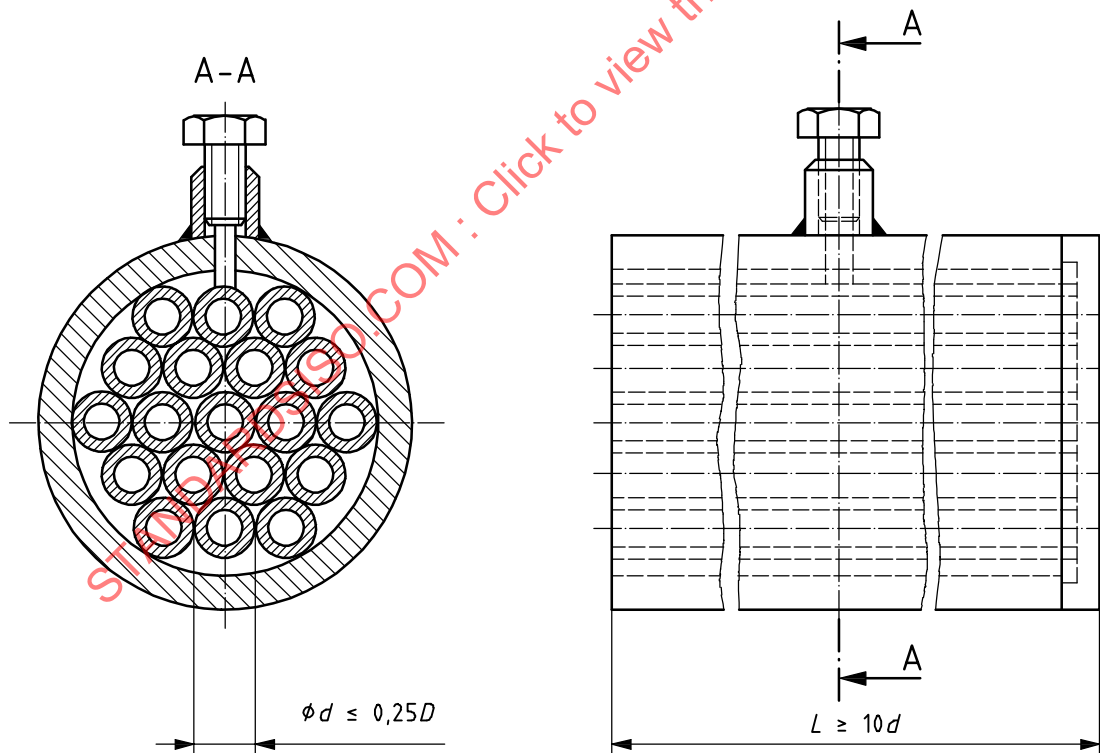

NOTE In order to decrease the pressure loss, the entrance to the tubes may be bevelled at 45°.

Figure 4 — Type C — Tube bundle straightener

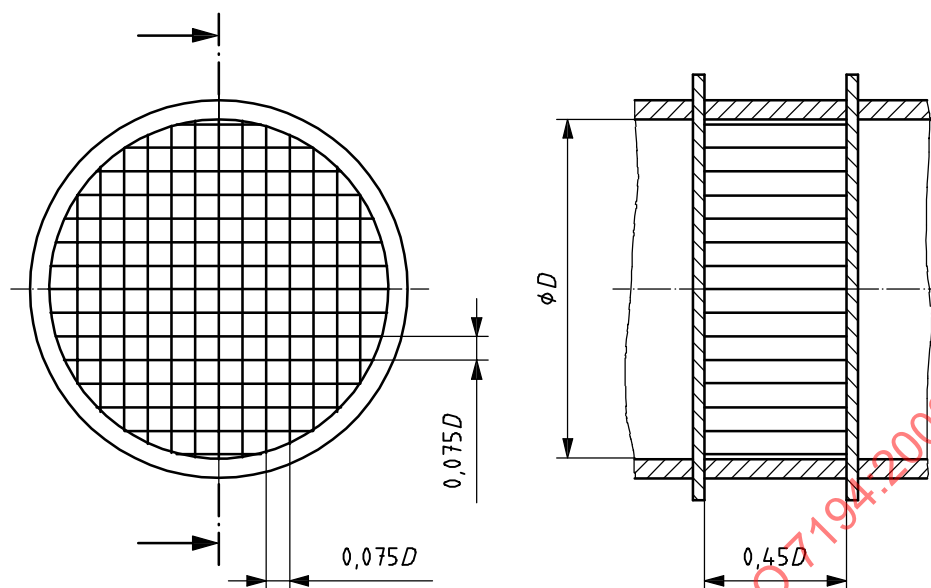

Figure 5 — Type D — AMCA straightener

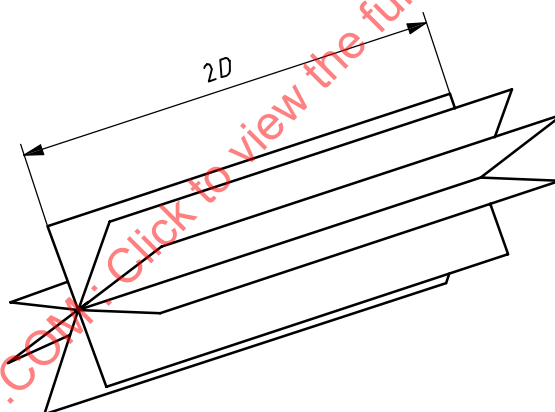

Figure 6 — Type E — Étoile straightener

## 7 Measurement of local velocities

Unless specific indications are given to the contrary elsewhere in this International Standard, the procedures to be followed and the conditions to be fulfilled by the local velocity measuring instruments shall conform to the specifications of ISO 3354 or ISO 3966.

When swirl occurs to any significant extent, the fact that the flow direction is different from the axial direction has an effect on the measuring instrument which has to be taken into account at each measuring position across the pipe in order to determine the local axial velocities. The procedure for doing this depends on whether a Pitot static tube or a current-meter is used.

## 7.1 Number and position of measuring points

The number and position of measuring points in the measuring section shall conform to the specifications of ISO 3354 or ISO 3966, taking into account the integration technique chosen. However, the minimum number of measurements per radius shall be five (excluding any measurement on the centre line) and, when there is reason to believe that the flow is asymmetric, the minimum number of radii shall be six. Also, at least one measurement of local velocity shall be made in each of the following zones within the pipe on each radius in addition to any measurement which might be made on the centre line:

$$0 < \left(\frac{r}{R}\right)^2 \leq 0,2$$

$$0,2 < \left(\frac{r}{R}\right)^2 \leq 0,4$$

$$0,4 < \left(\frac{r}{R}\right)^2 \leq 0,6$$

$$0,6 < \left(\frac{r}{R}\right)^2 \leq 0,8$$

$$0,8 < \left(\frac{r}{R}\right)^2 \leq 1,0$$

This condition is fulfilled automatically when the log-linear or log-Chebyshev methods of integration are used, but care has to be taken to choose the measuring positions in accordance with this requirement when either the numerical or graphical integration method is used.

Often, especially when there is reason to believe that the flow may be asymmetric, the uncertainty of flow measurement is reduced more by increasing the number of radii along which measurements are made than by increasing the number of points per radius. For example, if 48 current-meters are available for installation in a conduit, it is often slightly better to use six on each of eight radii rather than eight on each of six radii.

## 7.2 Effect of pressure fluctuations

In any conduit subject to flow covered by ISO 3966 or this International Standard, there are pressure fluctuations directly linked to the turbulent components of the local velocities superimposed on the mean flow. The traversing Pitot static tube transmits these to the manometer or pressure transducer as components of the instantaneous differential pressure. Sufficient damping in the manometer circuit helps the operator to estimate the average differential pressure, but such damping shall be symmetrical and linear, in order to avoid an additional error which cannot be assessed. The error in the mean velocity estimated from the mean differential pressure reading over time in the presence of turbulence is considered separately in Clause 8.

There shall be sufficient symmetrical and linear damping in the manometer circuit to ensure that fluctuations of the manometer reading at each point of measurement do not exceed  $\pm 3\%$  of the average reading at that point.

Recommendations on ensuring that damping is symmetrical and linear are given in Annex B.

Pressure fluctuations of acoustic origin, quite unrelated to the local flow velocities, may be present in some conduits, particularly those subject to gas flows. Such pressure fluctuations are usually much greater than those arising from turbulence and the smallest departure from linearity in damping of the manometer circuit inevitably leads to a considerable error in the local velocities estimated from the average manometer reading. Therefore, before measurements can be carried out in accordance with this International Standard, the user shall check that no significant regular pressure fluctuations are present in the conduit and, if there are, shall eliminate them. Advice on detection and removal is given in Annex A.

### 7.3 Axial velocity measurement using a Pitot static tube

Guidance on the use of Pitot static tubes is given in Annex D. The Pitot static tube used shall be one of those specified in ISO 3966, and measurement may be made by one of the two following methods.

In method A (see 7.3.1), the probe shall be aligned with the axis of the pipe at each measuring position, and use made of a knowledge of the response of the particular Pitot static tube at various angles of inclination to the local flow direction. This method may be used only for swirl angles up to  $20^\circ$ .

In method B (see 7.3.2), the Pitot static tube shall be aligned with the local flow direction at each measuring position; from a knowledge of the measured velocity and the angle the local velocity makes with the pipe axis, the axial velocity can be calculated. This method applies over the whole range covered by this International Standard (i.e. up to swirl angles of  $40^\circ$ ).

NOTE Fewer data are available at present to assess the uncertainty for method B than for method A.

In both cases, a preliminary traverse using a yaw probe is necessary to determine the angle of swirl at each of the measuring positions.

Two types of yaw probe are illustrated in Figures 7 and 8; in both cases, the method of use is to rotate them about the axis of their stem until the pressures from the two pressure taps are equal: the probe is at that stage aligned with the local direction of flow. Before use, a test should be made with appropriate facilities (e.g. in a wind tunnel) to determine the connection between this direction and a reference plane of the yaw probe itself.

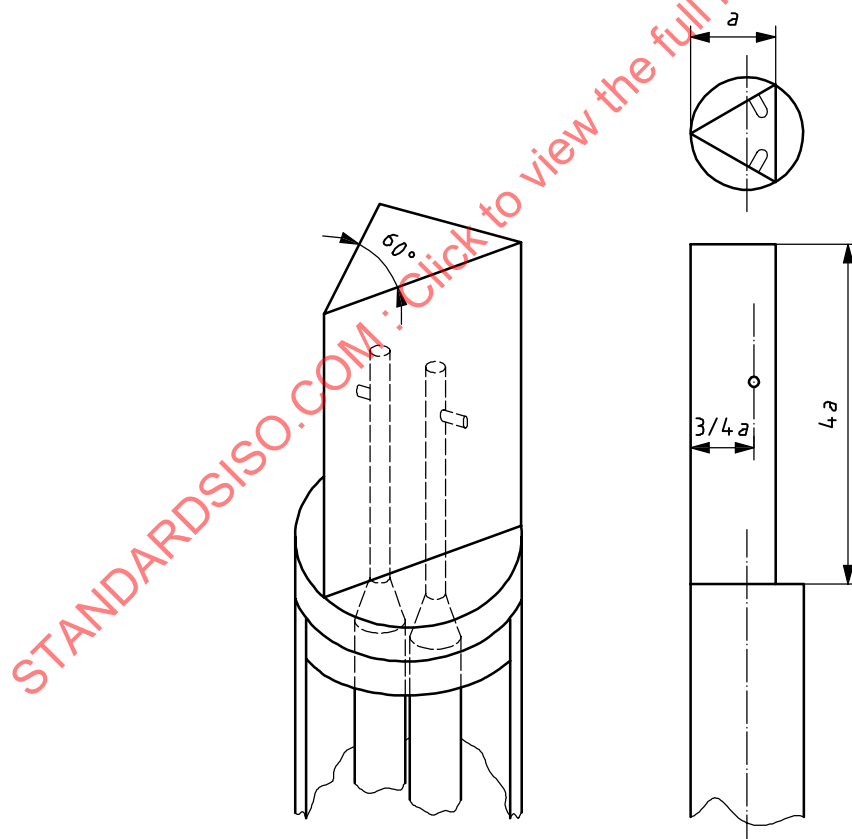

#### Key

$a$  perpendicular height of equilateral triangle

Figure 7 — Wedge-shaped yaw probe

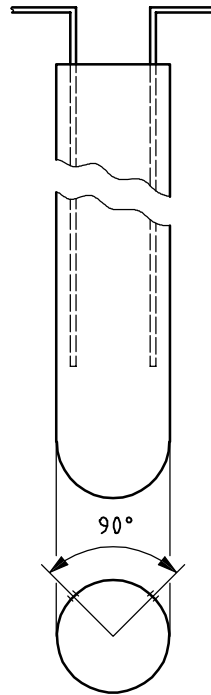

Figure 8 — Cylindrical yaw probe

7.3.1 Method A

This method may be used only when the angle which the local velocity makes with the axis of the pipe is less than 20° at all the measuring positions across the traverse plane. (The AMCA probe may only be used for swirl of up to 15° with method A, since information is not available on its response to greater yaw angles.)

The effect of swirl on the Pitot static tubes specified for use in this International Standard is given in Figure 9 for typical probes, but the directional response of the particular probe used for the measurement shall be determined from previous calibration in an appropriate facility (e.g. in a wind tunnel) since individual probes have different characteristics. The result of the calibration shall be expressed in terms of

$$k_\varphi = \cos \varphi \sqrt{\frac{\Delta p_0}{\Delta p_\varphi}}$$

versus the swirl angle  $\varphi$ , where  $\Delta p_0$  and  $\Delta p_\varphi$  are, for a given velocity, the values of differential pressure when the angle between the probe and the flow is zero and  $\varphi$ , respectively.

After determining the angle of swirl with a yaw probe at each of the measuring positions, the head of the Pitot static tube shall be aligned parallel to the axis of the duct at each position at which a measurement of local velocity is required, and the differential pressure noted. From measurements of individual differential pressures,  $\Delta p_\varphi$  and of individual angles of swirl, the individual point axial velocities,  $v_x$ , shall be calculated from the equation

$$v_x = k_\varphi \alpha (1 - \varepsilon) \sqrt{\frac{2\Delta p_\varphi}{\rho}}$$

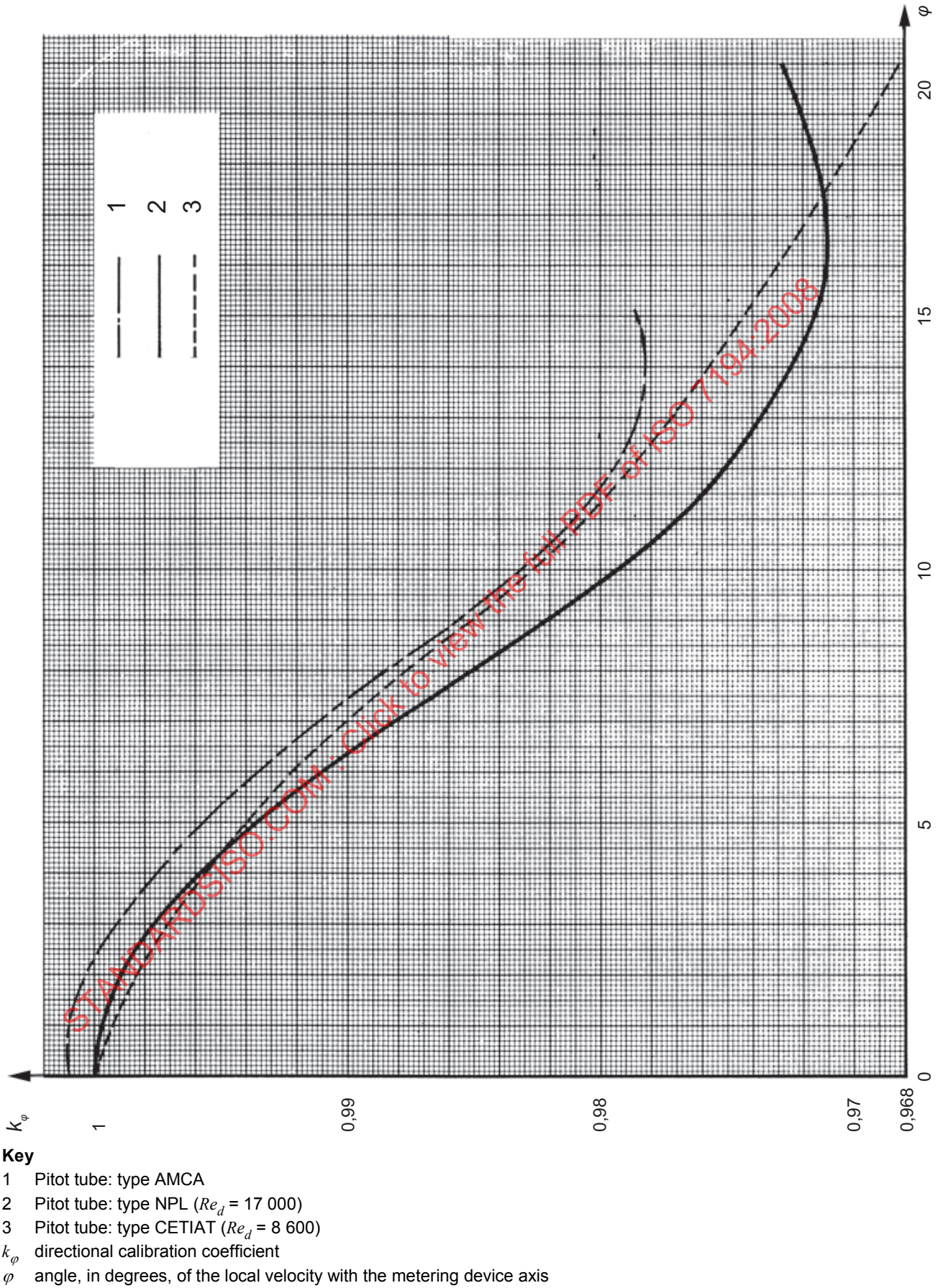

Figure 9 —  $k_\phi$  Versus  $\phi$  for typical Pitot static tubes

**7.3.2 Method B**

This method may be used only when the angle which the local velocity makes with the axis of the pipe is less than 40° at all of the measuring positions across the traverse plane.

After determining the angle of swirl with a yaw probe at each of the measuring positions, one of the Pitot static tubes specified in ISO 3966 shall be installed at each measuring position in turn. It shall be installed in such a way that the axis of the head is parallel to the local flow direction in each case. The differential pressures are then noted.

With this method, the radial positions of the nose of the Pitot static tube are different from those of the yaw probe whenever swirl is present. They are not located along a diameter of the duct, but follow a curved path. This is illustrated in Figure C.1 which shows typical positions of the Pitot static tube when axisymmetrical swirl occurs.

When prescribed locations of the Pitot static tube have to be used (as with the log-linear or log-Chebyshev integration techniques), it is necessary to calculate the positions at which the Pitot static tube heel has to be located in order that the nose is at these radial positions. Conversely, if the numerical or graphical integration technique is used, it is necessary to calculate the radial positions at which the Pitot static tube nose will be located in terms of the radial positions chosen for the heel. [See Equation (C.1).]

When method B is used, the maximum value of the local swirl angle limits the maximum usable diameter of the Pitot static tube head. Figure 10 shows the relationship between the maximum permissible value of the ratio,  $d/D$ , and the maximum local swirl angle, where  $d$  is the diameter of the Pitot static tube head and  $D$  the diameter of the duct.

The axial velocities shall be computed for each position from:

$$v_x = v \cos \theta$$

where

- $v_x$  is the axial velocity;
- $v$  is the magnitude of the vector velocity measured by probe, calculated as described in ISO 3966;
- $\theta$  is the angle that the flow makes with the axis of the duct.

STANDARDSISO.COM : Click to view the full PDF of ISO 7194:2008

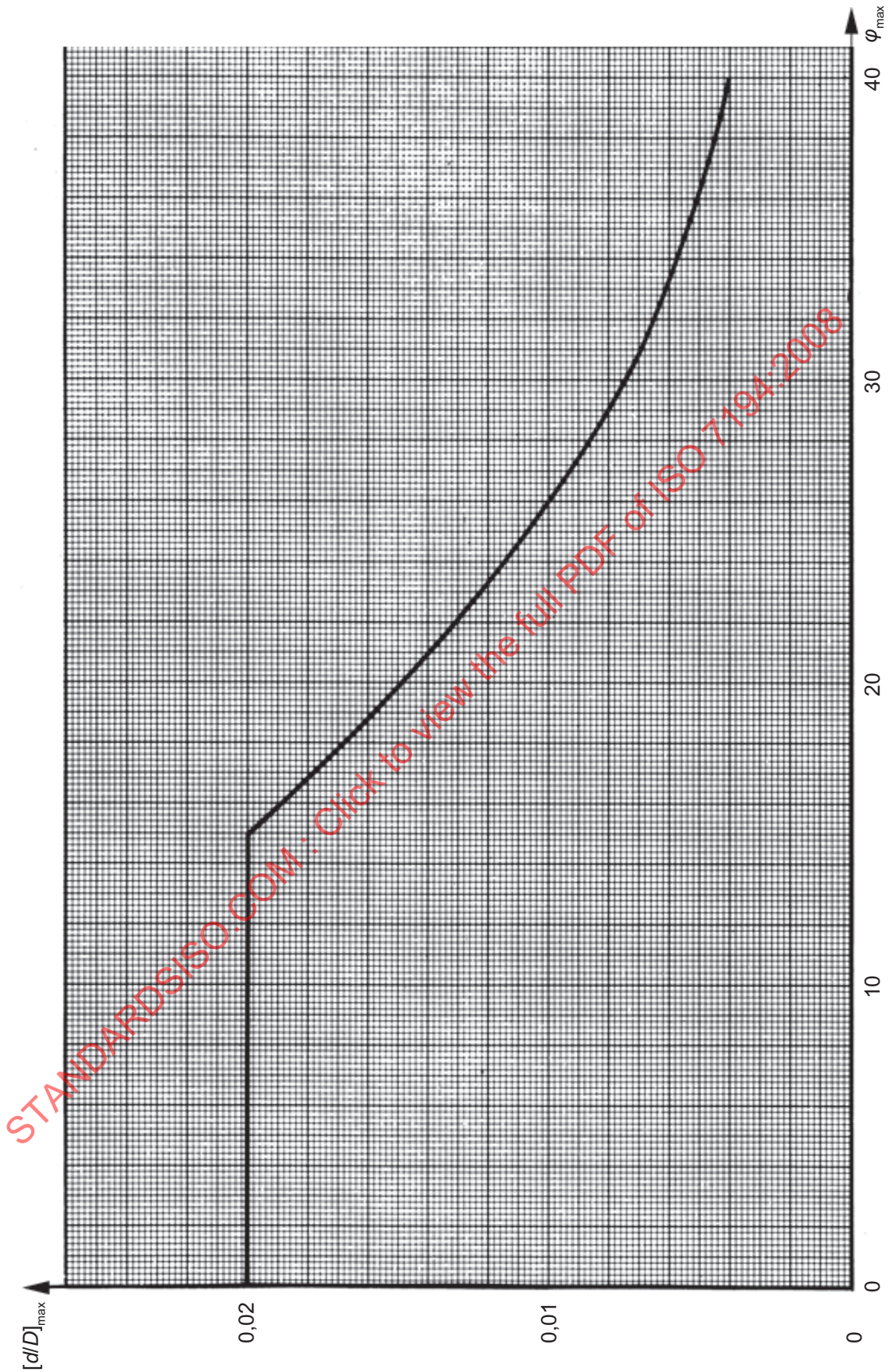

**Key**

- $\varphi_{\max}$  maximum local value of swirl angle, in degrees
- $[d/D]_{\max}$  maximum permissible value of  $d/D$

**Figure 10 — Maximum permissible size of Pitot static tube in method B**

#### 7.4 Axial velocity measurement using a current-meter

The effect of swirl on the response of a current-meter is not well known and basically depends (among other things) on the type of propeller. It is, however, possible to relate the response of a given propeller to the angle it makes with the direction of local velocity; such a calibration may be obtained by towing the current-meter in a calibration tank as specified (see ISO 3455:2007, 5.1), but aligning it successively at different angles with respect to the axis of the channel. Figure 11 shows, as an example, the response obtained in this way for certain specific propellers.

When it is believed that swirl is present at the measuring section, it is generally advisable to use a special "self-compensating" design of propeller, which has been designed to measure directly the axial component,  $v \cos \theta$ , of the local velocity for velocities which make an angle of up to  $30^\circ$  with the propeller axis. In cases where the swirl angle never exceeds  $30^\circ$ , no correction is therefore required for this type of propeller. It should, however, be noted that such propellers have the disadvantage of being particularly sensitive to the influence of the current-meter support and to turbulence in the flow.

If, for these reasons, the use of a conventional type of propeller is preferred, it is necessary to determine in advance the angle of swirl, e.g. by traversing the measuring section with a yaw probe as described in 7.3. If  $\theta$  is less than  $5^\circ$ , it can be assumed that a conventional propeller, aligned with the axis of the duct, will give a satisfactorily accurate measurement of the local axial velocity (the error will be less than  $\pm 1\%$ ). If  $\theta$  is between  $5^\circ$  and  $40^\circ$ , then the reading of a given propeller shall be corrected according to a previous calibration of that propeller which has established the response of the instrument to inclinations at different angles to the flow. Above  $40^\circ$ , it is not possible to make accurate measurements. Further guidance on the use of current-meters is given in Annex E.

### 8 Determination of mean flow velocity

The mean flow velocity shall be calculated by any of the integration techniques described in ISO 3354 or ISO 3966.

When a Pitot static tube is used, the turbulence of the flow produces an overestimate of the flow-rate (see ISO 3966:2008, Annex C) which, taking into account the particular conditions of the flows dealt with in this International Standard, lies generally between 1 % and 2 %. This overestimate depends not only on the turbulence level, but also on the shape of the Pitot tube nose and it decreases when the Reynolds number increases. The value of the mean flow velocity previously obtained shall therefore be reduced by an amount between 1 % and 2 %, according to the best estimate that the user of this International Standard shall derive, taking into account the particular conditions of the measurement (see Annex D).

When current-meters are used, no correction shall be applied to the measured value since, with these instruments, turbulence can introduce either positive or negative errors (see Annex E).

### 9 Accuracy of flow-rate estimation

The uncertainty in the measurement of flow-rate shall be calculated in accordance with ISO 5168. Thus if the independent variables which have to be measured in order to compute the flow-rate are  $X_1, X_2, \dots, X_k$ , the square of the absolute uncertainty,  $e_q^2$ , in the flow-rate is given by:

$$e_q^2 = \left[ \frac{\partial q}{\partial X_1} e_1 \right]^2 + \left[ \frac{\partial q}{\partial X_2} e_2 \right]^2 + \dots + \left[ \frac{\partial q}{\partial X_k} e_k \right]^2$$

where  $e_1, e_2, \dots, e_k$ , are the absolute uncertainties of  $X_1, X_2, \dots, X_k$ , respectively.

Since flow conditions can vary greatly, it is not possible to state that the flow-rate estimation will always have an uncertainty below some limiting value. It is however possible to give an indication of the order of magnitude of the errors which may arise in most cases.

### 9.1 Uncertainty arising from asymmetry

The percentage uncertainty,  $E_y$ , which might arise from this source is given by equations in Annex F depending on the number of radii along which traverses are made.

### 9.2 Uncertainty arising from swirl

The uncertainty which the existence of swirl might contribute to the flow-rate estimation will depend on the method and instrument used. There is little information on the effect of swirling flow in Pitot static tubes and current-meters.

For Pitot static tubes used with method A (7.3.1), there will be one error due to the determination of directional response of the probe and another error due to the fact that using a Pitot static tube in swirling flow is not exactly equivalent to inclining a Pitot tube in parallel flow: this was the case in the facility used to determine this response.

For Pitot static tubes used with method B (7.3.2), the main source of error due to the swirl is the not insignificant size of the probe and thus the effect of transverse velocity gradient.

For current-meters, the same sources of error as for Pitot tubes arise, increased by the fact that the conditions under which current-meters are calibrated depart still further from the operating conditions, the directional calibration being made generally by towing in still water.

In all cases, the percentage uncertainty,  $E_s$ , arising from swirl shall be assumed to increase with swirl angles. For the purpose of this International Standard, and for lack of more precise data, the value of  $E_s$  shall be taken as  $\pm 5\%$  of the maximum value (expressed in degrees) of swirl angle observed in the measuring section. For swirl angles above  $20^\circ$ , the assessment of the uncertainty is less reliable.

### 9.3 Uncertainty arising from turbulence

In swirling or asymmetric flow conditions, the level of turbulence is often higher than it usually is for more regular flows, as considered in ISO 3354 or ISO 3966; the uncertainty from this source of error is thereby increased.

For Pitot static tubes, after reducing the observed flow-rate as indicated in Clause 8, the value of the percentage uncertainty  $E_T$  arising from turbulence shall be taken as equal to the applied correction (i.e. within  $\pm 1\%$  to  $\pm 2\%$  according to the measuring conditions).

For current-meters, the axial and tangential components of the turbulence have opposite effects on the propellers normally used; these effects may partly compensate one another (see Annex E). It is possible, therefore, that turbulence introduces a smaller error to current-meter results than to Pitot tube results. Nevertheless, as a precaution, the percentage uncertainty,  $E_T$ , shall again be taken as being within  $\pm 1\%$  to  $\pm 2\%$  according to the measuring conditions.

### 9.4 Overall uncertainties

The methods for calculating the overall uncertainty of a flow-rate measurement by the velocity-area method, using current-meters or Pitot static tubes, are described in ISO 3354:2008, 11.6; and ISO 3966:2008, 13.6, respectively.

Furthermore, in asymmetric or swirling flow conditions, the uncertainties listed in 9.1 to 9.3 shall be taken into account as follows.

- The uncertainty arising from turbulence has already been allowed for in the equation for calculating the uncertainty in the local velocities (see ISO 3354:2008, 11.6.1; or ISO 3966:2008, 13.6.1), but the value to be included in this equation shall be chosen in accordance with 9.3.
- The uncertainties arising from asymmetry and/or from swirl shall be combined by the root-sum-square method with the other component uncertainties already listed in the equation for calculating the overall uncertainty in the flow-rate measurement (see ISO 3354:2008, 11.6.2; or ISO 3966:2008, 13.6.2). According to the flow conditions, one or both of these sources of error shall be taken into account.

As noted earlier, it is not possible to specify precise values for the various uncertainties involved. Nevertheless, as a guide, the overall uncertainty in flow-rate measurement in asymmetric or swirling flow conditions carried out in accordance with this International Standard is normally between  $\pm 2\%$  and  $\pm 4\%$ .

Higher uncertainties may result if the condition that there be no significant radial flow (see Clause 1) is not fulfilled.

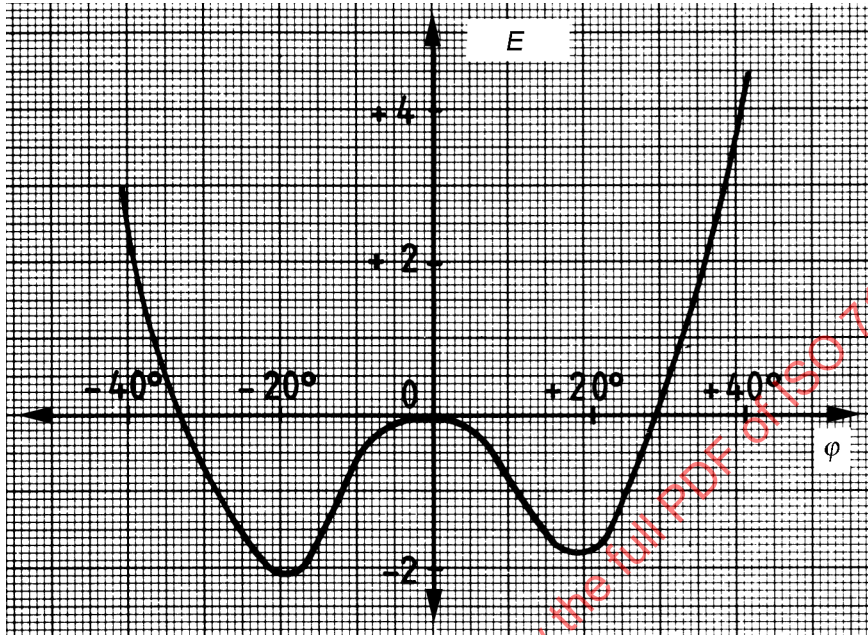

a) Percentage difference between the directional response of a twisted blade propeller and a law in  $\cos^2 \varphi$

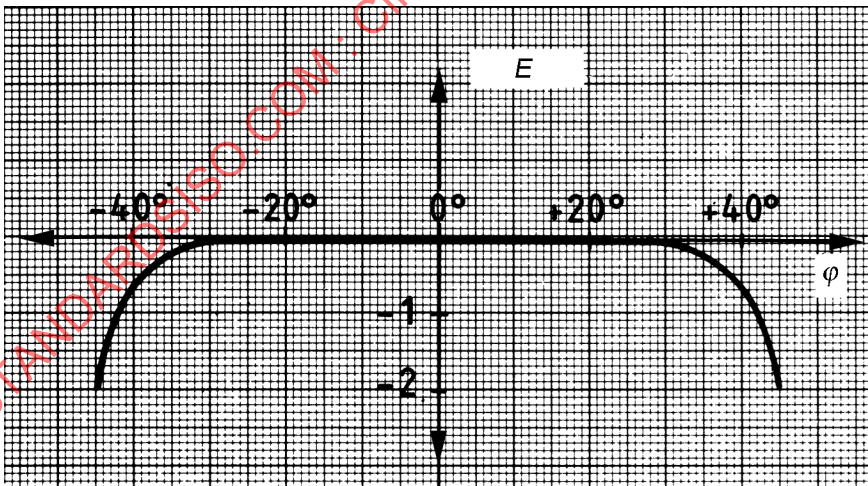

b) Percentage difference between the directional response of a self-compensating propeller and a law in  $\cos \varphi$

**Key**

$E$  error, as a percentage

$\varphi$  swirl angle, in degrees

Figure 11 — Examples of directional response of different types of current-meters

## Annex A (normative)

### Detection and removal of regular pressure fluctuations

Regular pressure fluctuations in the form of acoustic waves in a conduit can arise as a result of flow separation from fan or pump blades, amplified by organ pipe type resonance in a particular length of duct, or occasionally by the action of ring vortices in a duct with a constriction at each end. In the resulting regular pressure fluctuations, the pressure amplitudes are large, the velocity fluctuations are negligible (of the order of  $1/Ma$ , where  $Ma$  is the Mach number, times smaller than turbulence velocities for the same fluctuation pressure amplitude) and the frequencies can be far below the human audible range and, therefore, difficult to detect in the normal noisy environment of flow measurement. They are best detected by connecting a differential pressure transducer directly to the static pressure connection of the Pitot static tube, and to the total pressure connection through a long capillary tube, using a cathode ray oscilloscope to display the output. Because the velocity fluctuations of interest are so small, hot wire anemometers cannot be relied on to detect the pressure waves.

An alternative device (Reference [1]) is a simple, fast response, one-way valve, shown in Figure A.1, using a thin celluloid disc free to move about 0,1 mm between open and closed positions. A pair of such valves, inserted in the leads of the manometer connected to the traversing Pitot static tube, to permit free movement of the liquid in one direction only, might be expected to change the original manometer reading by about 60 % of the peak fluctuation of pressure in one direction. Reversal of the valves to check displacements in the other direction should show if any unsuspected large pressure fluctuations occur in the conduit.

Advice on the measurement of pulsating flow is given in ISO/TR 3313. In particular, the use of a bypass in preference to a control valve in the main circuit to regulate the flow is advised since the latter method can generate pulsations in the flow.

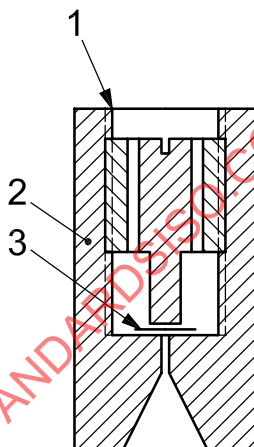

#### Key

- 1 screw thread
- 2 brass
- 3 celluloid valve disc

Figure A.1 — Non-return valve

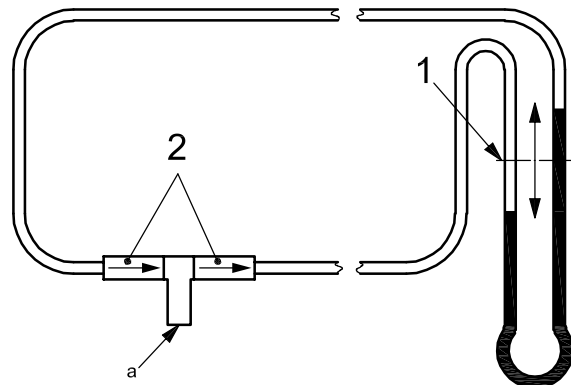

#### Key

- 1 steady reading on manometer
- 2 non-return valves
- a Fluctuating pressure applied here.

Figure A.2 — Arrangement of non-return valves

## Annex B (normative)

### Damping of manometers

#### B.1 Introduction

It is often necessary, to facilitate reading the manometer of differential pressure measuring devices, for the random pressure fluctuations to be damped without, however, concealing longer term fluctuations or falsifying the time average of the fluctuating pressure. The damping of the apparatus shall therefore be symmetrical and linear. When a sudden change in pressure is applied, the pressure indicator shall register 99 % of that change in not more than 60 s. Damping shall not be used to conceal regular pulsations of the pressure; measurement in such conditions is beyond the scope of this International Standard.

#### B.2 Damping procedure

Damping of the apparatus shall be effected using a resistance which is linear (i.e. proportional to the velocity) and symmetrical. Thus, every precaution shall be taken to avoid bending or pinching the rubber connecting pipes, and asymmetric nozzles, needle valves, or gate valves, etc. shall not be inserted between the Pitot static tube and the manometer.

A capillary tube of adequate length (i.e. 1 mm in diameter and 100 mm in length, if water is used as a manometric fluid) shall be incorporated, preferably in one of the manometer limbs (to ensure complete tightness of the connection) or in one of the leads close to the manometer; care shall be taken to avoid any sudden reduction or expansion of the connecting pipe which would bring about an appreciable head loss in comparison with the loss due to the capillary tube.

#### B.3 Balancing of damping

It is necessary to balance the damping of the two circuits (from the static pressure tapping to the manometer on the one hand and from the total pressure tapping to the manometer on the other). (The device described in Reference [2] is useful for this purpose.)

Such damping is essential, particularly when the time constant of the manometer is of the same order of magnitude as those of the two circuits connecting it to the Pitot static tube.

Figure B.1 shows a device that ensures that the damping in the two leads from the Pitot static tube to the manometer is the same. This is particularly suitable for air flows at pressures close to ambient conditions. If the rubber tube is suddenly squeezed, an equal positive pressure pulse will be applied to both total-pressure and static-pressure holes. An initial positive manometer reading will show the need for more damping in the total-pressure lead; an initial negative reading will indicate the need for more damping in the static-pressure lead. If the rubber tube is suddenly released to show the effect of a negative pressure pulse, the above manometer readings will be reversed.

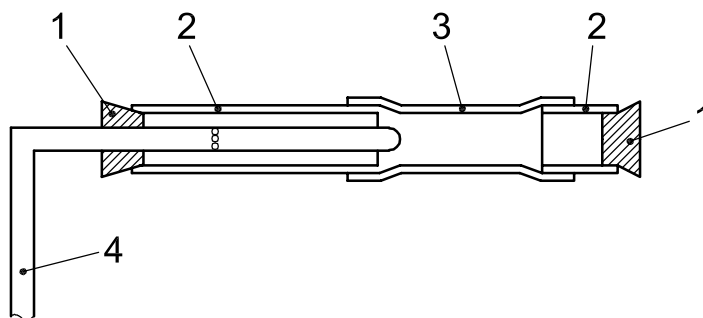
**Key**

- 1 rubber bung
- 2 metal tube
- 3 rubber tube
- 4 Pitot static tube

**Figure B.1 — Device for checking damping of pressure fluctuations in the leads to the manometer**

#### B.4 Checking of the damping

To ensure that the pressure gauge resistance is linear, i.e. that its operation corresponds to a laminar flow in the connections, check that the observed fluctuations correspond (for sinusoidal pulses) to a maximum fictitious Reynolds number well under 2 000. This fictitious Reynolds number is equal to

$$\frac{\pi S \Delta h d}{s t \nu}$$

where

- $S$  is the surface area of the meniscus;
- $s$  is the minimum section of the capillary tube used to damp the pressure gauge;
- $d$  is the diameter of the capillary tube;
- $\Delta h$  is the peak-to-peak magnitude of a fluctuation of the meniscus level;
- $t$  is the period of this fluctuation;
- $\nu$  is the kinematic viscosity of the fluid.

In order to verify the damping more precisely, a controllable source of fluctuating pressure (which can cause a sinusoidal pressure difference of sufficient amplitude and of zero mean value) shall be used. The mean position of oscillation of the meniscus then corresponds to the rest position (in the absence of driving pressure) if the resistance is actually symmetrical and linear.

## Annex C (normative)

### Calculation of Pitot static tube locations for method B

Method B specifies that the Pitot static tube shall be installed in such a way that the axis of the head of the tube is aligned with the local flow direction at each radial measuring position. Figure C.1 shows the nature of the locus of points at which the nose of the probe would be located if a swirling flow were present in the pipe.

These points are denoted by the crosses, and the circles give the corresponding positions of the heel of the Pitot static tube as it is located at successive positions across a diameter of the pipe.

The radial distance,  $y_1$ , between the nose of the Pitot static tube and the wall may be calculated from:

$$y_1 = R - \left[ (R - y)^2 + l^2 \sin^2 \theta \right]^{1/2} \quad (\text{C.1})$$

where

$R$  is the radius of the pipe;

$y$  is the distance between the Pitot static tube heel and the wall;

$l$  is the length of the head of the Pitot static tube;

$\theta$  is the angle between the axis of the Pitot static tube head and a line parallel to the pipe axis.

Equation (C.1) may also be used to calculate the position at which the heel of the Pitot static tube is to be located relative to the wall in order to position the nose of the Pitot static tube at a specified radial position. Equation (C.1) can then be written:

$$y = R - \left[ (R - y_1)^2 - l^2 \sin^2 \theta \right]^{1/2}$$

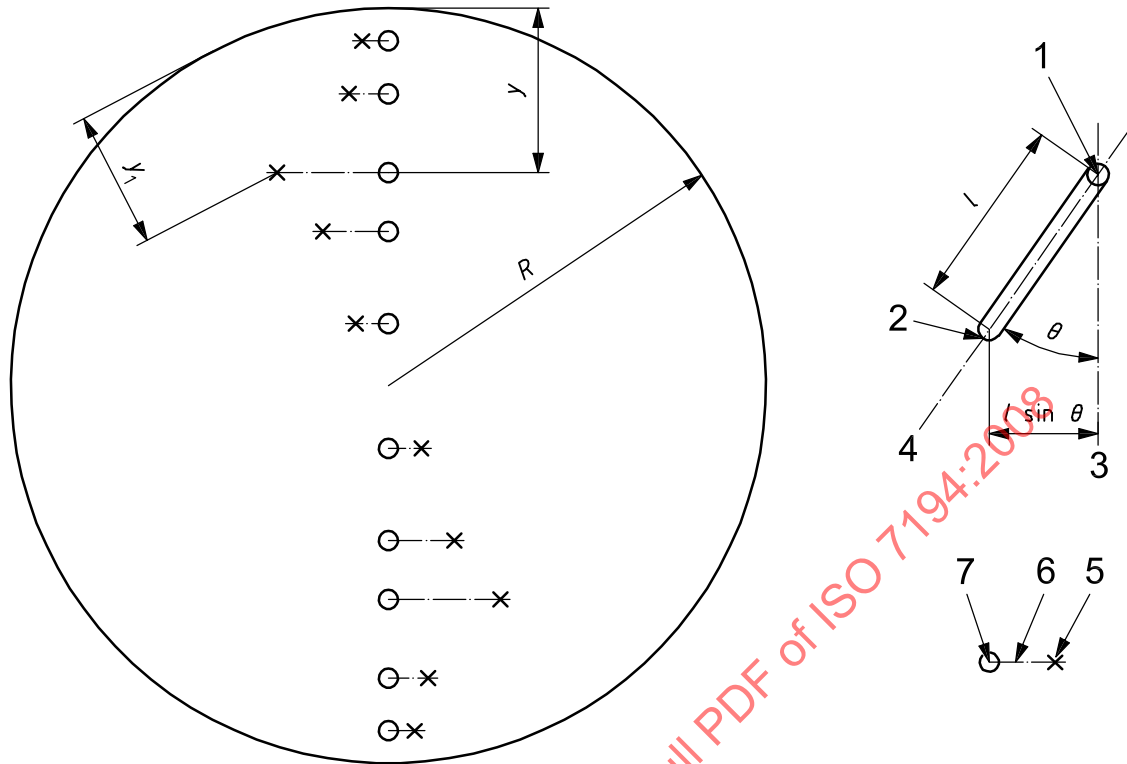

**Key**

- 1 Pitot static tube heel
- 2 Pitot static tube nose
- 3 axis of pipeline
- 4 axis of Pitot static tube head
- 5 nose
- 6 head axis
- 7 heel

Figure C.1 — Radial positions of Pitot static tube in swirling flow when method B is used

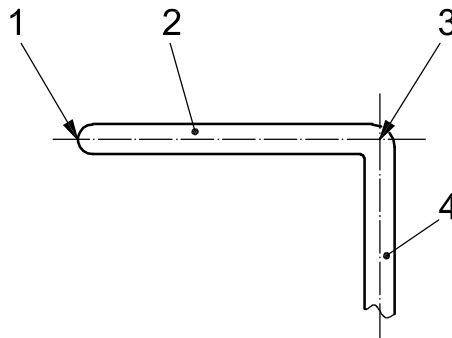

**Key**

- 1 nose
- 2 head
- 3 heel
- 4 stem

Figure C.2 — Pitot static tube