

---

---

**Information technology — Generic  
coding of moving pictures and  
associated audio information —**

**Part 1:  
Systems**

*Technologies de l'information — Codage générique des images  
animées et du son associé —*

*Partie 1: Systèmes*

STANDARDSISO.COM : Click to view the full PDF of ISO/IEC 13818-1:2023



STANDARDSISO.COM : Click to view the full PDF of ISO/IEC 13818-1:2023



**COPYRIGHT PROTECTED DOCUMENT**

© ISO/IEC 2023

All rights reserved. Unless otherwise specified, or required in the context of its implementation, no part of this publication may be reproduced or utilized otherwise in any form or by any means, electronic or mechanical, including photocopying, or posting on the internet or an intranet, without prior written permission. Permission can be requested from either ISO at the address below or ISO's member body in the country of the requester.

ISO copyright office  
CP 401 • Ch. de Blandonnet 8  
CH-1214 Vernier, Geneva  
Phone: +41 22 749 01 11  
Email: [copyright@iso.org](mailto:copyright@iso.org)  
Website: [www.iso.org](http://www.iso.org)

Published in Switzerland

## Foreword

ISO (the International Organization for Standardization) and IEC (the International Electrotechnical Commission) form the specialized system for worldwide standardization. National bodies that are members of ISO or IEC participate in the development of International Standards through technical committees established by the respective organization to deal with particular fields of technical activity. ISO and IEC technical committees collaborate in fields of mutual interest. Other international organizations, governmental and non-governmental, in liaison with ISO and IEC, also take part in the work.

The procedures used to develop this document and those intended for its further maintenance are described in the ISO/IEC Directives, Part 1. In particular, the different approval criteria needed for the different types of document should be noted.

ISO and IEC draw attention to the possibility that the implementation of this document may involve the use of (a) patent(s). ISO and IEC take no position concerning the evidence, validity or applicability of any claimed patent rights in respect thereof. As of the date of publication of this document, ISO and IEC had received notice of (a) patent(s) which may be required to implement this document. However, implementers are cautioned that this may not represent the latest information, which may be obtained from the patent database available at [www.iso.org/patents](http://www.iso.org/patents) and <https://patents.iec.ch>. ISO and IEC shall not be held responsible for identifying any or all such patent rights.

Any trade name used in this document is information given for the convenience of users and does not constitute an endorsement.

For an explanation of the voluntary nature of standards, the meaning of ISO specific terms and expressions related to conformity assessment, as well as information about ISO's adherence to the World Trade Organization (WTO) principles in the Technical Barriers to Trade (TBT) see [www.iso.org/iso/foreword.html](http://www.iso.org/iso/foreword.html). In the IEC, see [www.iec.ch/understanding-standards](http://www.iec.ch/understanding-standards).

This document was prepared by ITU-T (as ITU-T H.222.0) and drafted in accordance with its editorial rules, in collaboration with Joint Technical Committee ISO/IEC JTC 1, *Information technology*, Subcommittee SC 29, *Coding of audio, picture, multimedia and hypermedia information*.

This ninth edition cancels and replaces the eighth edition (ISO/IEC 13818-1:2022), which has been technically revised. It also incorporates the Amendment ISO/IEC 13818-1:2022/Amd 1:2023 and the Technical Corrigendum ISO/IEC 13818-1:2022/Cor 1:2023.

The main changes are as follows:

- updates references to ISO/IEC 14496-1 where clause numbering and field naming has changed;
- clarifies a reference to ISO/IEC 23008-3, where the field 3dAudioSceneInfoID is named differently;
- removes semantic definitions for fields that do not exist in the respective syntax table (Table 2-123);
- improves the semantic definition for HDR\_WCG\_idc equal to '0';
- corrects a mismatch in field size between syntax table and semantic definition of SubstreamOffset[k][j][i];
- corrects a misleading semantic definition of the media\_description\_flag for the Media\_service\_kind descriptor.

## ISO/IEC 13818-1:2023(E)

A list of all parts in the ISO/IEC 13818 series can be found on the ISO and IEC websites.

Any feedback or questions on this document should be directed to the user's national standards body. A complete listing of these bodies can be found at [www.iso.org/members.html](http://www.iso.org/members.html) and [www.iec.ch/national-committees](http://www.iec.ch/national-committees).

STANDARDSISO.COM : Click to view the full PDF of ISO/IEC 13818-1:2023

## CONTENTS

	<i>Page</i>
SECTION 1 – GENERAL.....	1
1.1 Scope.....	1
1.2 Normative references.....	1
SECTION 2 – TECHNICAL ELEMENTS .....	4
2.1 Definitions.....	4
2.2 Symbols and abbreviations .....	12
2.3 Method of describing bit stream syntax .....	14
2.4 Transport stream bitstream requirements.....	15
2.5 Program stream bitstream requirements.....	63
2.6 Program and program element descriptors.....	77
2.7 Restrictions on the multiplexed stream semantics .....	166
2.8 Compatibility with ISO/IEC 11172 .....	170
2.9 Registration of copyright identifiers .....	170
2.10 Registration of private data format.....	171
2.11 Carriage of ISO/IEC 14496 data .....	171
2.12 Carriage of metadata .....	183
2.13 Carriage of ISO 15938 data.....	192
2.14 Carriage of Rec. ITU-T H.264   ISO/IEC 14496-10 video .....	192
2.15 Carriage of ISO/IEC 14496-17 text streams .....	208
2.16 Carriage of auxiliary video streams .....	210
2.17 Carriage of HEVC.....	210
2.18 Carriage of green access units.....	224
2.19 Carriage of ISO/IEC 23008-3 MPEG-H 3D audio data.....	226
2.20 Carriage of Quality Access Units in MPEG-2 sections.....	228
2.21 Carriage of sample variants.....	229
2.22 Carriage of Media Orchestration Access Units.....	230
2.23 Carriage of VVC.....	230
2.24 Carriage of EVC .....	235
2.25 Carriage of LCEVC .....	238
Annex A CRC decoder model .....	240
A.1 CRC decoder model.....	240
Annex B Digital storage medium command and control (DSM-CC).....	241
B.1 Introduction.....	241
B.2 General elements.....	242
B.3 Technical elements.....	244
Annex C Program-specific information.....	250
C.1 Explanation of program-specific information in transport streams.....	250
C.2 Introduction.....	250
C.3 Functional mechanism .....	250
C.4 The mapping of sections into transport stream packets.....	251
C.5 Repetition rates and random access .....	251
C.6 What is a program? .....	252
C.7 Allocation of program_number.....	252
C.8 Usage of PSI in a typical system.....	252
C.9 The relationships of PSI structures .....	253
C.10 Bandwidth utilization and signal acquisition time .....	255
Annex D Systems timing model and application implications of this Recommendation   International Standard.....	258
D.1 Introduction.....	258
Annex E Data transmission applications .....	267
E.1 General considerations.....	267
E.2 Suggestion.....	267
Annex F Graphics of syntax for this Recommendation   International Standard.....	268

	<i>Page</i>
F.1 Introduction.....	268
Annex G General information .....	272
G.1 General information .....	272
Annex H Private data.....	273
H.1 Private data.....	273
Annex I Systems conformance and real-time interface .....	274
I.1 Systems conformance and real-time interface.....	274
Annex J Interfacing jitter-inducing networks to MPEG-2 decoders.....	275
J.1 Introduction.....	275
J.2 Network compliance models.....	275
J.3 Network specification for jitter smoothing .....	276
J.4 Example decoder implementations .....	277
Annex K Splicing transport streams .....	278
K.1 Introduction.....	278
K.2 The different types of splicing point .....	278
K.3 Decoder behaviour on splices .....	279
Annex L Registration procedure (see 2.9).....	281
L.1 Procedure for the request of a Registered Identifier (RID).....	281
L.2 Responsibilities of the Registration Authority .....	281
L.3 Responsibilities of parties requesting an RID .....	281
L.4 Appeal procedure for denied applications.....	281
Annex M Registration application form (see 2.9) .....	283
M.1 Contact information of organization requesting a Registered Identifier (RID).....	283
M.2 Statement of an intention to apply the assigned RID .....	283
M.3 Date of intended implementation of the RID .....	283
M.4 Authorized representative .....	283
M.5 For official use only of the Registration Authority .....	283
Annex N Registration Authority Diagram of administration structure (see 2.9).....	284
Annex O Registration procedure (see 2.10).....	285
O.1 Procedure for the request of an RID.....	285
O.2 Responsibilities of the Registration Authority .....	285
O.3 Contact information for the Registration Authority .....	285
O.4 Responsibilities of parties requesting an RID .....	285
O.5 Appeal procedure for denied applications.....	285
Annex P Registration application form .....	287
P.1 Contact information of organization requesting an RID .....	287
P.2 Request for a specific RID .....	287
P.3 Short description of RID that is in use and date system that was implemented.....	287
P.4 Statement of an intention to apply the assigned RID .....	287
P.5 Date of intended implementation of the RID .....	287
P.6 Authorized representative .....	287
P.7 For official use of the Registration Authority .....	287
Annex Q T-STD and P-STD buffer models for ISO/IEC 13818-7 ADTS .....	288
Q.1 Introduction.....	288
Q.2 Leak rate from transport buffer .....	288
Q.3 Buffer size.....	288
Q.4 Conclusion .....	289
Annex R Carriage of ISO/IEC 14496 scenes in Rec. ITU-T H.222.0   ISO/IEC 13818-1 .....	291
R.1 Content access procedure for ISO/IEC 14496 program components within a program stream.....	291
R.2 Content access procedure for ISO/IEC 14496 program components within a transport stream .....	292
Annex S Carriage of JPEG 2000 part 1 video over MPEG-2 transport streams.....	296
S.1 Introduction.....	296

	<i>Page</i>
S.2 J2K video access unit, J2K video elementary stream, J2K video sequence and J2K still picture .....	296
S.3 Optional J2K block mode for high resolution support .....	296
S.4 Optional J2K stripe mode for Ultra-Low Latency .....	297
S.5 Elementary stream header (elsm) and mapping to PES packets .....	297
S.6 J2K transport constraints .....	300
S.7 Interpretation of flags in adaptation and PES headers for J2K video elementary streams .....	301
S.8 T-STD extension for J2K video elementary streams .....	301
Annex T MIME type for MPEG-2 transport streams .....	304
T.1 Introduction .....	304
T.2 MIME type and subtype .....	304
T.3 Security considerations .....	305
T.4 Parameters .....	305
Annex U Carriage of timeline and external media information over MPEG-2 transport streams .....	307
U.1 Introduction .....	307
U.2 TEMI access unit and TEMI elementary stream .....	308
U.3 AF descriptors .....	309
Annex V Transport of HEVC tiles .....	318
V.1 Introduction .....	318
V.2 HEVC tile substream identification example .....	319
V.3 Subregion layout example .....	319
Annex W Carriage of JPEG XS part 1 video over MPEG-2 Transport Streams .....	321
W.1 Introduction .....	321
W.2 JPEG XS video access unit, JPEG XS video elementary stream, JPEG XS video sequence and JPEG XS still picture .....	321
W.3 Elementary stream header (jxes) and mapping to PES packets .....	321
W.4 JPEG XS transport constraints .....	322
W.5 Interpretation of flags in adaptation field and PES packet for JPEG XS video elementary streams .....	323
W.6 T-STD extension for JPEG XS video elementary streams .....	323
Bibliography .....	326

## List of Tables

	<i>Page</i>
Table 2-1 – Transport stream.....	26
Table 2-2 – Transport packet of this Recommendation   International Standard.....	26
Table 2-3 – PID table .....	27
Table 2-4 – Scrambling control values .....	27
Table 2-5 – Adaptation field control values .....	28
Table 2-6 – Transport stream adaptation field.....	28
Table 2-7 – Splice parameters Table 1 Simple Profile Main Level, Main Profile Main Level, SNR Profile Main Level (both layers), Spatial Profile High-1440 Level (base layer), High Profile Main Level (middle + base layers), Multi-view Profile Main Level (base layer) Video .....	35
Table 2-8 – Splice parameters Table 2 Main Profile Low Level, SNR Profile Low Level (both layers), High Profile Main Level (base layer), Multi-view Profile Low Level (base layer) Video.....	35
Table 2-9 – Splice parameters Table 3 Main Profile High-1440 Level, Spatial Profile High-1440 Level (all layers), High Profile High-1440 Level (middle + base layers), Multi-view Profile High-1440 Level (base layer) Video.....	36
Table 2-10 – Splice parameters Table 4 Main Profile High Level, High Profile High-1440 Level (all layers), High Profile High Level (middle + base layers), Multi-view Profile High Level (base layer) Video.....	36
Table 2-11 – Splice parameters Table 5 SNR Profile Low Level (base layer) Video .....	36
Table 2-12 – Splice parameters Table 6 SNR Profile Main Level (base layer) Video .....	36
Table 2-13 – Splice parameters Table 7 Spatial Profile High-1440 Level (middle + base layers) Video .....	37
Table 2-14 – Splice parameters Table 8 High Profile Main Level (all layers), High Profile High-1440 Level (base layer) Video .....	37
Table 2-15 – Splice parameters Table 9 High Profile High Level (base layer), Multi-view Profile Main Level (both layers) Video .....	37
Table 2-16 – Splice parameters Table 10 High Profile High Level (all layers), Multi-view Profile High-1440 Level (both layers) Video .....	38
Table 2-17 – Splice parameters Table 11 4:2:2 Profile Main Level Video .....	38
Table 2-18 – Splice parameters Table 12 Multi-view Profile Low Level (both layers) Video.....	38
Table 2-19 – Splice parameters Table 13 Multi-view Profile High Level (both layers) Video.....	38
Table 2-20 – Splice parameters Table 14 4:2:2 Profile High Level Video.....	39
Table 2-21 – PES packet .....	39
Table 2-22 – Stream_id assignments.....	42
Table 2-23 – PES scrambling control values.....	43
Table 2-24 – Trick mode control values.....	48
Table 2-25 – Field_id field control values.....	49
Table 2-26 – Coefficient selection values.....	49
Table 2-27 – Stream_id_extension assignments.....	51
Table 2-28 – Program-specific information.....	52
Table 2-29 – Program-specific information pointer .....	54
Table 2-30 – Program association section .....	54
Table 2-31 – table_id assignment values.....	55
Table 2-32 – Conditional access section.....	56
Table 2-33 – Transport stream program map section .....	57
Table 2-34 – Stream type assignments .....	58
Table 2-35 – Private section .....	61
Table 2-36 – The transport stream description table .....	62
Table 2-37 – Program stream .....	68
Table 2-38 – Program stream pack.....	68
Table 2-39 – Program stream pack header .....	69
Table 2-40 – Program stream system header.....	70
Table 2-41 – Program stream map.....	73
Table 2-42 – Program stream directory packet.....	75
Table 2-43 – Intra_coded indicator.....	76
Table 2-44 – Coding_parameters indicator .....	77
Table 2-45 – Program and program element descriptors.....	77
Table 2-46 – Video stream descriptor .....	79

	<i>Page</i>
Table 2-47 – Frame rate code .....	79
Table 2-48 – Audio stream descriptor .....	80
Table 2-49 – Hierarchy descriptor .....	80
Table 2-50 – Hierarchy_type field values .....	82
Table 2-51 – Registration descriptor .....	82
Table 2-52 – Data stream alignment descriptor .....	83
Table 2-53 – Video stream alignment values .....	83
Table 2-54 – AVC video stream alignment values .....	84
Table 2-55 – HEVC video stream alignment values .....	84
Table 2-56 – Audio stream alignment values .....	84
Table 2-57 – VVC video stream alignment values .....	85
Table 2-58 – EVC video stream alignment values .....	85
Table 2-59 – Target background grid descriptor .....	86
Table 2-60 – Video window descriptor .....	86
Table 2-61 – Conditional access descriptor .....	87
Table 2-62 – ISO 639 language descriptor .....	87
Table 2-63 – Audio type values .....	88
Table 2-64 – System clock descriptor .....	89
Table 2-65 – Multiplex buffer utilization descriptor .....	89
Table 2-66 – Copyright descriptor .....	90
Table 2-67 – Maximum bitrate descriptor .....	90
Table 2-68 – Private data indicator descriptor .....	91
Table 2-69 – Smoothing buffer descriptor .....	91
Table 2-70 – STD descriptor .....	92
Table 2-71 – IBP descriptor .....	92
Table 2-72 – MPEG-4 video descriptor .....	93
Table 2-73 – MPEG-4 audio descriptor .....	93
Table 2-75 – IOD descriptor .....	96
Table 2-76 – SL descriptor .....	96
Table 2-77 – FMC descriptor .....	97
Table 2-78 – External_ES_ID descriptor .....	97
Table 2-79 – Muxcode descriptor .....	98
Table 2-80 – M4MuxBufferSize descriptor .....	98
Table 2-81 – MultiplexBuffer descriptor .....	99
Table 2-82 – M4MuxTiming descriptor .....	99
Table 2-83 – Content labelling descriptor .....	100
Table 2-84 – Metadata_application_format .....	100
Table 2-85 – Content_time_base_indicator values .....	101
Table 2-86 – Metadata pointer descriptor .....	102
Table 2-87 – Metadata format values .....	102
Table 2-88 – MPEG_carriage_flags .....	103
Table 2-89 – Metadata descriptor .....	104
Table 2-90 – decoder_config_flags .....	105
Table 2-91 – Metadata STD descriptor .....	106
Table 2-92 – AVC video descriptor .....	106
Table 2-93 – AVC timing and HRD descriptor .....	108
Table 2-94 – MPEG-2 AAC_audio_descriptor .....	109
Table 2-95 – MPEG-2_AAC_additional_information field values .....	110
Table 2-96 – MPEG-4 text descriptor .....	110
Table 2-97 – MPEG-4 audio extension descriptor .....	110
Table 2-98 – Auxiliary video stream descriptor .....	111
Table 2-99 – SVC extension descriptor .....	112
Table 2-100 – MVC extension descriptor .....	113
Table 2-101 – J2K video descriptor .....	114

	<i>Page</i>
Table 2-102 – Example frame rates based on DEN_frame_rate and NUM_frame_rate values .....	116
Table 2-103 – MVC operation point descriptor.....	118
Table 2-104 – MPEG2_stereoscopic_video_format_descriptor syntax .....	119
Table 2-105 – Stereoscopic_program_info_descriptor syntax .....	119
Table 2-106 – Stereoscopic_service_type values .....	120
Table 2-107 – Stereoscopic_video_info_descriptor syntax .....	120
Table 2-108 – Upsampling factor values.....	121
Table 2-109 – Extension descriptor.....	121
Table 2-110 – Extension descriptor tag values .....	124
Table 2-111 – Transport_profile_descriptor syntax .....	125
Table 2-112 – Transport_profile values .....	125
Table 2-113 – HEVC video descriptor .....	126
Table 2-114 – Semantics of HDR_WGC_idc.....	128
Table 2-115 – HEVC timing and HRD descriptor.....	128
Table 2-116 – Adaptation field extension descriptor.....	129
Table 2-117 – HEVC operation point descriptor.....	130
Table 2-118 – HEVC hierarchy extension descriptor.....	132
Table 2-119 – Semantics of extension dimension bits.....	132
Table 2-120 – Green extension descriptor.....	133
Table 2-121 – MPEG-H 3D audio descriptor.....	134
Table 2-122 – MPEG-H 3D audio config descriptor.....	134
Table 2-123 – MPEG-H 3D audio scene descriptor .....	135
Table 2-124 – MPEG-H 3D audio text label descriptor .....	138
Table 2-125 – MPEG-H 3D audio multi-stream descriptor.....	140
Table 2-126 – MPEG-H 3D audio DRC and Loudness descriptor.....	141
Table 2-127 – MPEG-H 3D audio command descriptor .....	143
Table 2-128 – Quality extension descriptor.....	144
Table 2-129 – Virtual segmentation descriptor .....	145
Table 2-130 – HEVC tile substream descriptor.....	146
Table 2-131 – HEVC subregion descriptor .....	147
Table 2-132 – JPEG XS video descriptor.....	149
Table 2-133 – VVC video descriptor.....	151
Table 2-134 – Semantics of HDR_WGC_idc.....	152
Table 2-135 – SDR widely used video property combinations .....	153
Table 2-136 – WCG widely used video property combinations.....	153
Table 2-137 – HDR/WCG widely used video property combinations .....	153
Table 2-138 – No Indication.....	154
Table 2-139 – VVC timing and HRD descriptor.....	154
Table 2-140 – EVC video descriptor.....	156
Table 2-141 – EVC timing and HRD descriptor .....	157
Table 2-142 – LCEVC video descriptor.....	158
Table 2-143 – LCEVC linkage descriptor .....	159
Table 2-144 – Media service kind descriptor .....	160
Table 2-145 – media_description_flag .....	160
Table 2-146 – Media type indicator.....	160
Table 2-147 – ID_length_code .....	161
Table 2-148 – ID_type.....	161
Table 2-149 – configuration type values .....	161
Table 2-150 – lang_len_indicator.....	162
Table 2-151 – Media service type values .....	162
Table 2-152 – Carriage of individual ISO/IEC 14496 streams in Rec. ITU-T H.222.0   ISO/IEC 13818-1 .....	172
Table 2-153 – Section syntax for transport of ISO/IEC 14496 stream.....	177
Table 2-154 – ISO/IEC defined options for carriage of an ISO/IEC 14496 scene and associated streams in Rec. ITU-T H.222.0   ISO/IEC 13818-1 .....	180
Table 2-155 – Metadata Access Unit Wrapper.....	187

	<i>Page</i>
Table 2-156 – Metadata AU cell .....	187
Table 2-157 – Cell fragment indication.....	187
Table 2-158 – Section syntax for transport of metadata .....	188
Table 2-159 – Section fragment indication.....	189
Table 2-160 – View and dependency representation delimiter NAL unit .....	198
Table 2-161 – Implied hierarchy_layer_index if no hierarchy descriptors are used.....	218
Table 2-162 – Green access unit section syntax .....	225
Table 2-163 – Green access unit.....	225
Table 2-164 – Quality Access Unit .....	228
Table B.1 – DSM-CC syntax.....	245
Table B.2 – Command_id assigned values.....	245
Table B.3 – DSM-CC control.....	246
Table B.4 – Select mode assigned values.....	247
Table B.5 – DSM-CC Acknowledgement .....	248
Table B.6 – Time code .....	249
Table C.1 – Composite_descriptor .....	255
Table C.2 – Sub-descriptor.....	255
Table C.3 – Program association table bandwidth usage (bit/s) Number of programs per transport stream .....	256
Table C.4 – Program map table bandwidth usage (bit/s) Number of programs per transport stream.....	256
Table D.1 – Re-multiplexing strategy .....	263
Table E.1 – PES packet header example .....	267
Table S.1 – J2K Access unit elementary stream header .....	298
Table S.2 – Operating levels and maximum buffer size for JPEG 2000 broadcast profiles (from Table A.49 in Rec. ITU-T T.800 (2015)   ISO/IEC 15444-1:2016) .....	303
Table T.1 – 'codecs' parameter values for some specific stream_type values .....	305
Table U.1 – Variable field length notation.....	307
Table U.1bis – Table U.1 in equivalent full notation .....	308
Table U.2 – TEMI access unit.....	308
Table U.3 – AF descriptor tags.....	309
Table U.4 – TEMI location descriptor.....	310
Table U.5 – TEMI URL scheme types .....	310
Table U.6 – TEMI service types.....	311
Table U.7 – TEMI base URL descriptor.....	311
Table U.8 – TEMI timeline descriptor .....	312
Table U.9 – TEMI MPEG-H_3dAudio_extStreamID descriptor .....	314
Table U.10 – Boundary descriptor.....	315
Table U.11 – sequence_number_length_code interpretation.....	315
Table U.12 – Labelling Descriptor .....	316
Table U.13 – label_length_code interpretation.....	316
Table U.14 – label_type values .....	317
Table U.15 – HEVC tile substream af_descriptor .....	317
Table W.1 – JPEG XS Access unit elementary stream header (jxes header) .....	321

## List of Figures

	<i>Page</i>
Figure Intro. 1 – Simplified overview of the scope of this Recommendation   International Standard .....	xiv
Figure Intro. 2 – Prototypical transport demultiplexing and decoding example.....	xvi
Figure Intro. 3 – Prototypical transport multiplexing example.....	xvi
Figure Intro. 4 – Prototypical transport stream to program stream conversion .....	xvi
Figure Intro. 5 – Prototypical decoder for program streams.....	xvii
Figure 2-1 – Transport stream system target decoder notation.....	16
Figure 2-2 – Program stream system target decoder notation .....	63
Figure 2-3 – Target background grid descriptor display area.....	85
Figure 2-4 – Media Service Kind Descriptor semantics at program level.....	165
Figure 2-5 – Media Program Kind Descriptor semantics at elementary stream level .....	165
Figure 2-6 – T-STD model extensions for individual ISO/IEC 14496 elementary streams .....	172
Figure 2-7 – T-STD model for ISO/IEC 14496 content .....	178
Figure 2-8 – P-STD model for ISO/IEC 14496 Systems stream .....	181
Figure 2-9 – Timing model for delivery of content and metadata .....	184
Figure 2-10 – Delivery of metadata in PES packets .....	185
Figure 2-11 – Metadata signalling and referencing .....	191
Figure 2-12 – Metadata decoding in the STD.....	191
Figure 2-13 – T-STD model extensions for Rec. ITU-T H.264   ISO/IEC 14496-10 video.....	195
Figure 2-14 – P-STD model extensions for Rec. ITU-T H.264   ISO/IEC 14496-10 video .....	197
Figure 2-15 – T-STD model extensions for Rec. ITU-T H.264   ISO/IEC 14496-10 Video with scalable video sub-bitstreams.....	198
Figure 2-16 – P-STD model extensions for Rec. ITU-T H.264   ISO/IEC 14496-10 Video with scalable video sub-bitstreams.....	201
Figure 2-17 – T-STD model extensions for Rec. ITU-T H.264   ISO/IEC 14496-10 Video with MVC video sub-bitstreams.....	203
Figure 2-18 – P-STD model extensions for Rec. ITU-T H.264   ISO/IEC 14496-10 Video with MVC video sub-bitstreams.....	207
Figure 2-19 – T-STD model extensions for ISO/IEC 14496-17 text streams.....	209
Figure 2-20 – T-STD model extensions for single layer HEVC.....	212
Figure 2-21 – T-STD model extensions for layered transport of HEVC temporal video subsets.....	214
Figure 2-22 – T-STD model extensions for bitstream-partition-specific CPB operation .....	216
Figure 2-23 – T-STD model extensions for transport of HEVC tiles through individual ESs .....	220
Figure 2-24 – T-STD model extensions for transport of HEVC tiles in a common ES using AF descriptors.....	222
Figure 2-25 – T-STD model extension for transport of HEVC tiles in a common ES ignoring AF descriptors .....	224
Figure 2-26 – T-STD model extension for green access units.....	226
Figure 2-27 – Transport stream system target decoder for multiple audio elementary streams .....	228
Figure 2-28 – Quality Access Unit decoder processing model.....	229
Figure 2-29 – T-STD model extensions for single layer VVC.....	231
Figure 2-30 – T-STD model extensions for layered transport of VVC temporal video subsets .....	233
Figure 2-31 – T-STD model extensions for single layer EVC .....	236
Figure A.1 – 32-bit CRC decoder model.....	240
Figure B.1 – Configuration of DSM-CC application.....	243
Figure B.2 – BSM-CC bitstream decoded as a stand-alone bitstream .....	243
Figure B.3 – DSM-CC bitstream decoded as part of the system bitstream .....	244
Figure C.1 – Program and network mapping relationships .....	253
Figure D.1 – Constant delay model .....	258
Figure D.2 – STC recovery using PLL.....	262
Figure F.1 – Transport stream syntax diagram .....	268
Figure F.2 – PES packet syntax diagram.....	269
Figure F.3 – Program association section diagram.....	269
Figure F.4 – Conditional access section diagram .....	269
Figure F.5 – TS program map section diagram .....	270
Figure F.6 – Private section diagram .....	270
Figure F.7 – Program stream diagram .....	271

	<i>Page</i>
Figure F.8 – Program stream map diagram .....	271
Figure J.1 – Sending system streams over a jitter-inducing network .....	276
Figure J.2 – Jitter-smoothing using network-layer timestamps .....	276
Figure J.3 – Integrated dejittering and MPEG-2 decoding .....	277
Figure R.1 – Example of ISO/IEC 14496 content in a program stream .....	292
Figure R.2 – Example of ISO/IEC 14496 content in a transport stream.....	293
Figure R.3 – Usage of MPEG-4 in a transport stream with BIFS scene referring to native PES .....	294
Figure R.4 – Usage of MPEG-4 in a transport stream with an ODUpdate_descriptor carrying an image ObjectDescriptor in the PMT.....	295
Figure S.1 – Structure and order of JPEG 2000 access units.....	300
Figure S.2 – T-STD model extensions for J2K Video.....	301
Figure U.1 – Stream partitioning into 2 and 5 second segments .....	315
Figure V.1 – Illustration of HEVC tiled encoding of panoramic content beyond UHD.....	318
Figure V.2 – Example of HEVC tile substream identification .....	319
Figure V.3 – Example of subregion layout for a 3 x 3 RoI .....	319
Figure W.1 – Structure and order of JPEG XS access units.....	322
Figure W.2 – T-STD model extensions for JPEG XS Video.....	324

STANDARDSISO.COM : Click to view the full PDF of ISO/IEC 13818-1:2023

**Introduction**

The systems part of this Recommendation | International Standard addresses the combining of one or more elementary streams of video and audio, as well as other data, into single or multiple streams which are suitable for storage or transmission. Systems coding follows the syntactical and semantic rules imposed by this Specification and provides information to enable synchronized decoding of decoder buffers over a wide range of retrieval or receipt conditions.

System coding shall be specified in two forms: the transport stream and the program stream. Each is optimized for a different set of applications. Both the transport stream and program stream defined in this Recommendation | International Standard provide coding syntax which is necessary and sufficient to synchronize the decoding and presentation of the video and audio information, while ensuring that data buffers in the decoders do not overflow or underflow. Information is coded in the syntax using time stamps concerning the decoding and presentation of coded audio and visual data and time stamps concerning the delivery of the data stream itself. Both stream definitions are packet-oriented multiplexes.

The basic multiplexing approach for single video and audio elementary streams is illustrated in Figure Intro. 1. The video and audio data is encoded as described in Rec. ITU-T H.262 | ISO/IEC 13818-2 and ISO/IEC 13818-3. The resulting compressed elementary streams are packetized to produce PES packets. Information needed to use PES packets independently of either transport streams or program streams may be added when PES packets are formed. This information is not needed and need not be added when PES packets are further combined with system level information to form transport streams or program streams. This systems standard covers those processes to the right of the vertical dashed line.

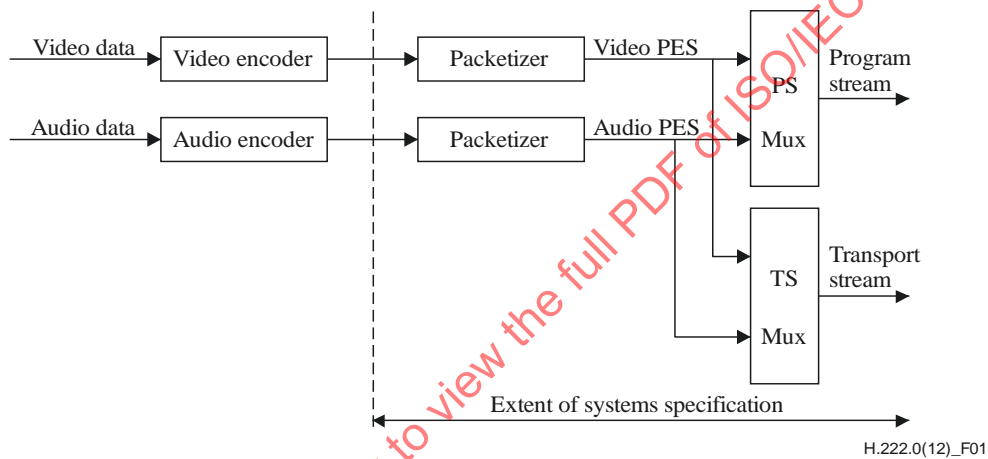

**Figure Intro. 1 – Simplified overview of the scope of this Recommendation | International Standard**

The program stream is analogous and similar to the ISO/IEC 11172 systems layer. It results from combining one or more streams of PES packets, which have a common time base, into a single stream.

For applications that require the elementary streams that comprise a single program to be in separate streams that are not multiplexed, the elementary streams can also be encoded as separate program streams, one per elementary stream, with a common time base. In this case the values encoded in the SCR fields of the various streams shall be consistent.

Like the single program stream, all elementary streams can be decoded with synchronization.

The program stream is designed for use in relatively error-free environments and is suitable for applications which may involve software processing of system information such as interactive multi-media applications. Program stream packets may be of variable and relatively great length.

The transport stream combines one or more programs with one or more independent time bases into a single stream. PES packets made up of elementary streams that form a program share a common time base. The transport stream is designed for use in environments where errors are likely, such as storage or transmission in lossy or noisy media. Transport stream packets are 188 bytes in length.

Program and transport streams are designed for different applications and their definitions do not strictly follow a layered model. It is possible and reasonable to convert from one to the other; however, one is not a subset or superset of the other. In particular, extracting the contents of a program from a transport stream and creating a valid program stream is possible and is accomplished through the common interchange format of PES packets, but not all of the fields needed in a program stream are contained within the transport stream; some must be derived. The transport stream may be used to span a range of layers in a layered model, and is designed for efficiency and ease of implementation in high bandwidth applications.

The scope of syntactical and semantic rules set forth in the systems specification differs: the syntactical rules apply to systems layer coding only, and do not extend to the compression layer coding of the video and audio specifications; by contrast, the semantic rules apply to the combined stream in its entirety.

The systems specification does not specify the architecture or implementation of encoders or decoders, nor those of multiplexors or demultiplexors. However, bit stream properties do impose functional and performance requirements on encoders, decoders, multiplexors and demultiplexors. For instance, encoders must meet minimum clock tolerance requirements. Notwithstanding this and other requirements, a considerable degree of freedom exists in the design and implementation of encoders, decoders, multiplexors, and demultiplexors.

## Intro. 1 Transport stream

The transport stream is a stream definition which is tailored for communicating or storing one or more programs of coded data according to Rec. ITU-T H.262 | ISO/IEC 13818-2 and ISO/IEC 13818-3 and other data in environments in which significant errors may occur. Such errors may be manifested as bit value errors or loss of packets.

Transport streams may be either fixed or variable rate. In either case the constituent elementary streams may either be fixed or variable rate. The syntax and semantic constraints on the stream are identical in each of these cases. The transport stream rate is defined by the values and locations of program clock reference (PCR) fields, which in general are separate PCR fields for each program.

There are some difficulties with constructing and delivering a transport stream containing multiple programs with independent time bases such that the overall bit rate is variable. Refer to 2.4.2.3.

The transport stream may be constructed by any method that results in a valid stream. It is possible to construct transport streams containing one or more programs from elementary coded data streams, from program streams, or from other transport streams which may themselves contain one or more programs.

The transport stream is designed in such a way that several operations on a transport stream are possible with minimum effort. Among these are:

- 1) Retrieve the coded data from one program within the transport stream, decode it and present the decoded results as shown in Figure Intro. 2.
- 2) Extract the transport stream packets from one program within the transport stream and produce as output a different transport stream with only that one program as shown in Figure Intro. 3.
- 3) Extract the transport stream packets of one or more programs from one or more transport streams and produce as output a different transport stream (not illustrated).
- 4) Extract the contents of one program from the transport stream and produce as output a program stream containing that one program as shown in Figure Intro. 4.
- 5) Take a program stream, convert it into a transport stream to carry it over a lossy environment, and then recover a valid, and in certain cases, identical program stream.

Figure Intro. 2 and Figure Intro. 3 illustrate prototypical demultiplexing and decoding systems which take as input a transport stream. Figure Intro. 2 illustrates the first case, where a transport stream is directly demultiplexed and decoded. Transport streams are constructed in two layers:

- a system layer; and
- a compression layer.

The input stream to the transport stream decoder has a system layer wrapped about a compression layer. Input streams to the video and audio decoders have only the compression layer.

Operations performed by the prototypical decoder which accepts transport streams either apply to the entire transport stream ("multiplex-wide operations"), or to individual elementary streams ("stream-specific operations"). The transport stream system layer is divided into two sub-layers, one for multiplex-wide operations (the transport stream packet layer), and one for stream-specific operations (the PES packet layer).

A prototypical decoder for transport streams, including audio and video, is also depicted in Figure Intro. 2 to illustrate the function of a decoder. The architecture is not unique – some system decoder functions, such as decoder timing control, might equally well be distributed among elementary stream decoders and the channel-specific decoder – but this figure is useful for discussion. Likewise, indication of errors detected by the channel-specific decoder to the individual audio and video decoders may be performed in various ways and such communication paths are not shown in the diagram. The prototypical decoder design does not imply any normative requirement for the design of a transport stream decoder. Indeed non-audio/video data is also allowed, but not shown.

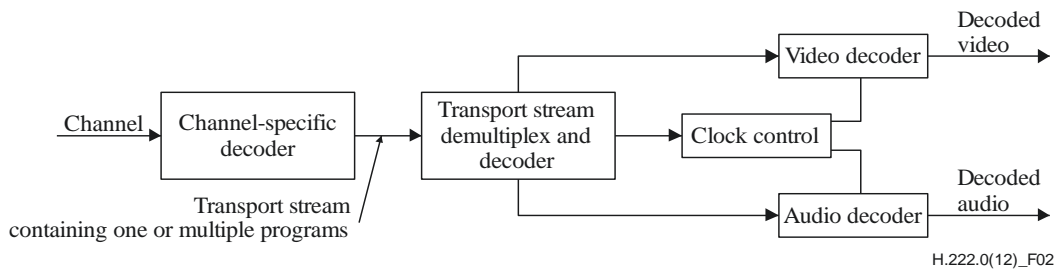

**Figure Intro. 2 – Prototypical transport demultiplexing and decoding example**

Figure Intro. 3 illustrates the second case, where a transport stream containing multiple programs is converted into a transport stream containing a single program. In this case the re-multiplexing operation may necessitate the correction of program clock reference (PCR) values to account for changes in the PCR locations in the bit stream.

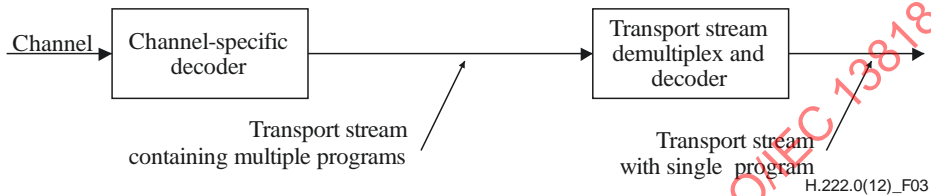

**Figure Intro. 3 – Prototypical transport multiplexing example**

Figure Intro. 4 illustrates a case in which a multi-program transport stream is first demultiplexed and then converted into a program stream.

Figures Intro. 3 and Intro. 4 indicate that it is possible and reasonable to convert between different types and configurations of transport streams. There are specific fields defined in the transport stream and program stream syntax which facilitate the conversions illustrated. There is no requirement that specific implementations of demultiplexors or decoders include all of these functions.

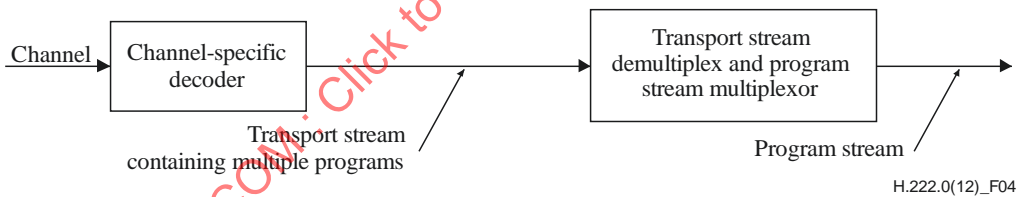

**Figure Intro. 4 – Prototypical transport stream to program stream conversion**

**Intro. 2 Program stream**

The program stream is a stream definition which is tailored for communicating or storing one program of coded data and other data in environments where errors are very unlikely, and where processing of system coding, e.g., by software, is a major consideration.

Program streams may be either fixed or variable rate. In either case, the constituent elementary streams may be either fixed or variable rate. The syntax and semantics constraints on the stream are identical in each case. The program stream rate is defined by the values and locations of the system clock reference (SCR) and mux\_rate fields.

A prototypical audio/video program stream decoder system is depicted in Figure Intro. 5. The architecture is not unique – system decoder functions including decoder timing control might as equally well be distributed among elementary stream decoders and the channel-specific decoder – but this figure is useful for discussion. The prototypical decoder design does not imply any normative requirement for the design of a program stream decoder. Indeed, non-audio/video data is also allowed, but not shown.

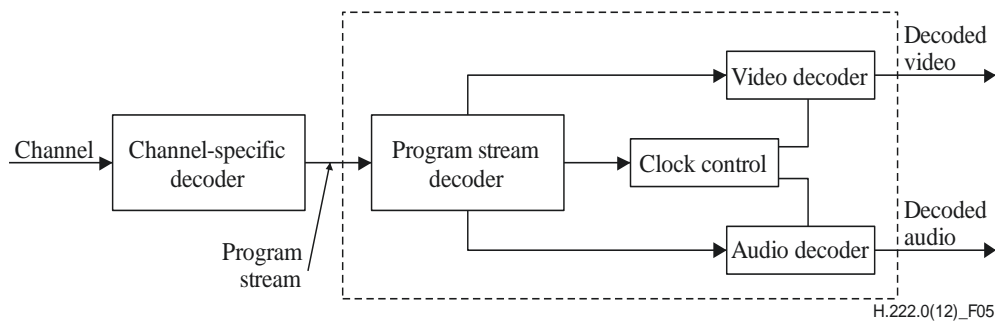

**Figure Intro. 5 – Prototypical decoder for program streams**

The prototypical decoder for program streams shown in Figure Intro. 5 is composed of system, video and audio decoders conforming to Parts 1, 2 and 3, respectively, of ISO/IEC 13818. In this decoder, the multiplexed coded representation of one or more audio and/or video streams is assumed to be stored or communicated on some channel in some channel-specific format. The channel-specific format is not governed by this Recommendation | International Standard, nor is the channel-specific decoding part of the prototypical decoder.

The prototypical decoder accepts as input a program stream and relies on a program stream decoder to extract timing information from the stream. The program stream decoder demultiplexes the stream, and the elementary streams so produced serve as inputs to video and audio decoders, whose outputs are decoded video and audio signals. Included in the design, but not shown in the figure, is the flow of timing information among the program stream decoder, the video and audio decoders, and the channel-specific decoder. The video and audio decoders are synchronized with each other and with the channel using this timing information.

Program streams are constructed in two layers: a system layer and a compression layer. The input stream to the program stream decoder has a system layer wrapped about a compression layer. Input streams to the video and audio decoders have only the compression layer.

Operations performed by the prototypical decoder either apply to the entire program stream ("multiplex-wide operations"), or to individual elementary streams ("stream-specific operations"). The program stream system layer is divided into two sub-layers, one for multiplex-wide operations (the pack layer), and one for stream-specific operations (the PES packet layer).

### Intro. 3 Conversion between transport stream and program stream

It may be possible and reasonable to convert between transport streams and program streams by means of PES packets. This results from the specification of transport stream and program stream as embodied in 2.4.1 and 2.5.1 of the normative requirements of this Recommendation | International Standard. PES packets may, with some constraints, be mapped directly from the payload of one multiplexed bit stream into the payload of another multiplexed bit stream. It is possible to identify the correct order of PES packets in a program to assist with this if the `program_packet_sequence_counter` is present in all PES packets.

Certain other information necessary for conversion, e.g., the relationship between elementary streams, is available in tables and headers in both streams. Such data, if available, shall be correct in any stream before and after conversion.

### Intro. 4 Packetized elementary stream

Transport streams and program streams are each logically constructed from PES packets, as indicated in the syntax definitions in 2.4.3.6. PES packets shall be used to convert between transport streams and program streams; in some cases the PES packets need not be modified when performing such conversions. PES packets may be much larger than the size of a transport stream packet.

A continuous sequence of PES packets of one elementary stream with one stream ID may be used to construct a PES Stream. When PES packets are used to form a PES stream, they shall include elementary stream clock reference (ESCR) fields and elementary stream rate (ES\_Rate) fields, with constraints as defined in 2.4.3.8. The PES stream data shall be contiguous bytes from the elementary stream in their original order. PES streams do not contain some necessary system information which is contained in program streams and transport streams. Examples include the information in the pack header, system header, program stream map, program stream directory, program map table, and elements of the transport stream packet syntax.

The PES stream is a logical construct that may be useful within implementations of this Recommendation | International Standard; however, it is not defined as a stream for interchange and interoperability. Applications requiring streams containing only one elementary stream can use program streams or transport streams which each contain only one elementary stream. These streams contain all of the necessary system information. Multiple program streams or transport streams, each containing a single elementary stream, can be constructed with a common time base and therefore carry a complete program, i.e., with audio and video.

#### **Intro. 5      Timing model**

Systems, video and audio all have a timing model in which the end-to-end delay from the signal input to an encoder to the signal output from a decoder is a constant. This delay is the sum of encoding, encoder buffering, multiplexing, communication or storage, demultiplexing, decoder buffering, decoding, and presentation delays. As part of this timing model all video pictures and audio samples are presented exactly once, unless specifically coded to the contrary, and the inter-picture interval and audio sample rate are the same at the decoder as at the encoder. The system stream coding contains timing information which can be used to implement systems which embody constant end-to-end delay. It is possible to implement decoders which do not follow this model exactly; however, in such cases it is the decoder's responsibility to perform in an acceptable manner. The timing is embodied in the normative specifications of this Recommendation | International Standard, which must be adhered to by all valid bit streams, regardless of the means of creating them.

All timing is defined in terms of a common system clock, referred to as a system time clock (STC). In the program stream this clock may have an exactly specified ratio to the video or audio sample clocks, or it may have an operating frequency which differs slightly from the exact ratio while still providing precise end-to-end timing and clock recovery.

In the transport stream the system clock frequency is constrained to have the exactly specified ratio to the audio and video sample clocks at all times; the effect of this constraint is to simplify sample rate recovery in decoders.

#### **Intro. 6      Conditional access**

Encryption and scrambling for conditional access to programs encoded in the program and transport streams is supported by the system data stream definitions. Conditional access mechanisms are not specified here. The stream definitions are designed so that implementation of practical conditional access systems is reasonable, and there are some syntactical elements specified which provide specific support for such systems.

#### **Intro. 7      Multiplex-wide operations**

Multiplex-wide operations include the coordination of data retrieval of the channel, the adjustment of clocks, and the management of buffers. The tasks are intimately related. If the rate of data delivery of the channel is controllable, then data delivery may be adjusted so that decoder buffers neither overflow nor underflow; but if the data rate is not controllable, then elementary stream decoders must slave their timing to the data received from the channel to avoid overflow or underflow.

Program streams are composed of packs whose headers facilitate the above tasks. Pack headers specify intended times at which each byte is to enter the program stream Decoder from the channel, and this target arrival schedule serves as a reference for clock correction and buffer management. The schedule need not be followed exactly by decoders, but they must compensate for deviations about it.

Similarly, transport streams are composed of transport stream packets with headers containing information which specifies the times at which each byte is intended to enter a transport stream decoder from the channel. This schedule provides exactly the same function as that which is specified in the program stream.

An additional multiplex-wide operation is a decoder's ability to establish what resources are required to decode a transport stream or program stream. The first pack of each program stream conveys parameters to assist decoders in this task. Included, for example, are the stream's maximum data rate and the highest number of simultaneous video channels. The transport stream likewise contains globally useful information.

The transport stream and program stream each contain information which identifies the pertinent characteristics of, and relationships between, the elementary streams which constitute each program. Such information may include the language spoken in audio channels, as well as the relationship between video streams when multi-layer video coding is implemented.

#### **Intro. 8      Individual stream operations (PES packet layer)**

The principal stream-specific operations are:

- 1) demultiplexing; and
- 2) synchronizing playback of multiple elementary streams.

**Intro. 8.1 Demultiplexing**

On encoding, program streams are formed by multiplexing elementary streams, and transport streams are formed by multiplexing elementary streams, program streams, or the contents of other transport streams. Elementary streams may include private, reserved, and padding streams in addition to audio and video streams. The streams are temporally subdivided into packets, and the packets are serialized. A PES packet contains coded bytes from one and only one elementary stream.

In the program stream both fixed and variable packet lengths are allowed subject to constraints as specified in 2.5.1 and 2.5.2. For transport streams the packet length is 188 bytes. Both fixed and variable PES packet lengths are allowed, and will be relatively long in most applications.

On decoding, demultiplexing is required to reconstitute elementary streams from the multiplexed program stream or transport stream. Stream\_id codes in program stream packet headers, and packet ID codes in the transport stream make this possible.

**Intro. 8.2 Synchronization**

Synchronization among multiple elementary streams is accomplished with presentation time stamps (PTSs) in the program stream and transport streams. Time stamps are generally in units of 90 kHz, but the system clock reference (SCR), the program clock reference (PCR) and the optional elementary stream clock reference (ESCR) have extensions with a resolution of 27 MHz. Decoding of N-elementary streams is synchronized by adjusting the decoding of streams to a common master time base rather than by adjusting the decoding of one stream to match that of another. The master time base may be one of the N-decoders' clocks, the data source's clock, or it may be some external clock.

Each program in a transport stream, which may contain multiple programs, may have its own time base. The time bases of different programs within a transport stream may be different.

Because PTSs apply to the decoding of individual elementary streams, they reside in the PES packet layer of both the transport streams and program streams. End-to-end synchronization occurs when encoders save time stamps at capture time, when the time stamps propagate with associated coded data to decoders, and when decoders use those time stamps to schedule presentations.

Synchronization of a decoding system with a channel is achieved through the use of the SCR in the program stream and by its analogue, the PCR, in the transport stream. The SCR and PCR are time stamps encoding the timing of the bit stream itself, and are derived from the same time base used for the audio and video PTS values from the same program. Since each program may have its own time base, there are separate PCR fields for each program in a transport stream containing multiple programs. In some cases it may be possible for programs to share PCR fields. Refer to 2.4.4, program-specific information (PSI), for the method of identifying which PCR is associated with a program. A program shall have one and only one PCR time base associated with it.

**Intro. 8.3 Relation to compression layer**

The PES packet layer is independent of the compression layer in some senses, but not in all. It is independent in the sense that PES packet payloads need not start at compression layer start codes, as defined in Parts 2 and 3 of ISO/IEC 13818. For example, video start codes may occur anywhere within the payload of a PES packet, and start codes may be split by a PES packet header. However, time stamps encoded in PES packet headers apply to presentation times of compression layer constructs (namely, presentation units). In addition, when the elementary stream data conforms to Rec. ITU-T H.262 | ISO/IEC 13818-2 or ISO/IEC 13818-3, the PES\_packet\_data\_bytes shall be byte aligned to the bytes of this Recommendation | International Standard.

**Intro. 9 System reference decoder**

Part 1 of ISO/IEC 13818 employs a "system target decoder" (STD), one for transport streams (refer to 2.4.2) referred to as "transport system target decoder" (T-STD) and one for program streams (refer to 2.5.2) referred to as "program system target decoder" (P-STD), to provide a formalism for timing and buffering relationships. Because the STD is parameterized in terms of Rec. ITU-T H.222.0 | ISO/IEC 13818-1 fields (for example, buffer sizes) each elementary stream leads to its own parameterization of the STD. Encoders shall produce bit streams that meet the appropriate STD's constraints. Physical decoders may assume that a stream plays properly on its STD. The physical decoder must compensate for ways in which its design differs from that of the STD.

**Intro. 10 Applications**

The streams defined in this Recommendation | International Standard are intended to be as useful as possible to a wide variety of applications. Application developers should select the most appropriate stream.

## ISO/IEC 13818-1:2023

Modern data communications networks may be capable of supporting Rec. ITU-T H.222.0 | ISO/IEC 13818-1 video and ISO/IEC 13818 audio. A real-time transport protocol is required. The program stream may be suitable for transmission on such networks.

The program stream is also suitable for multimedia applications on CD-ROM. Software processing of the program stream may be appropriate.

The transport stream may be more suitable for error-prone environments, such as those used for distributing compressed bit-streams over long-distance networks and in broadcast systems.

Many applications require storage and retrieval of Rec. ITU-T H.222.0 | ISO/IEC 13818-1 bitstreams on various digital storage media (DSM). A digital storage media command and control (DSM-CC) protocol is specified in Annex B and Part 6 of ISO/IEC 13818 in order to facilitate the control of such media.

STANDARDSISO.COM : Click to view the full PDF of ISO/IEC 13818-1:2023

**INTERNATIONAL STANDARD  
ITU-T RECOMMENDATION**

**Information technology – Generic coding of moving pictures and  
associated audio information: Systems**

**SECTION 1 – GENERAL**

**1.1 Scope**

This Recommendation | International Standard specifies the system layer of the coding. It was developed principally to support the combination of the video and audio coding methods defined in Parts 2 and 3 of ISO/IEC 13818. The system layer supports six basic functions:

- 1) the synchronization of multiple compressed streams on decoding;
- 2) the interleaving of multiple compressed streams into a single stream;
- 3) the initialization of buffering for decoding start up;
- 4) continuous buffer management;
- 5) time identification;
- 6) multiplexing and signalling of various components in a system stream

A Rec. ITU-T H.222.0 | ISO/IEC 13818-1 multiplexed bit stream is either a transport stream or a program stream. Both streams are constructed from PES packets and packets containing other necessary information. Both stream types support multiplexing of video and audio compressed streams from one program with a common time base. The transport stream additionally supports the multiplexing of video and audio compressed streams from multiple programs with independent time bases. For almost error-free environments the program stream is generally more appropriate, supporting software processing of program information. The transport stream is more suitable for use in environments where errors are likely.

A Rec. ITU-T H.222.0 | ISO/IEC 13818-1 multiplexed bit stream, whether a transport stream or a program stream, is constructed in two layers: the outermost layer is the system layer, and the innermost is the compression layer. The system layer provides the functions necessary for using one or more compressed data streams in a system. The video and audio parts of this Specification define the compression coding layer for audio and video data. Coding of other types of data is not defined by this Specification, but is supported by the system layer provided that the other types of data adhere to the constraints defined in 2.7.

**1.2 Normative references**

The following Recommendations and International Standards contain provisions which, through reference in this text, constitute provisions of this Recommendation | International Standard. At the time of publication, the editions indicated were valid. All Recommendations and Standards are subject to revision, and parties to agreements based on this Recommendation | International Standard are encouraged to investigate the possibility of applying the most recent edition of the Recommendations and Standards listed below. Members of IEC and ISO maintain registers of currently valid International Standards. The Telecommunication Standardization Bureau of the ITU maintains a list of currently valid ITU-T Recommendations.

**1.2.1 Identical Recommendations | International Standards**

- Recommendation ITU-T H.262 (2012) | ISO/IEC 13818-2:2013, *Information technology – Generic coding of moving pictures and associated audio information: Video*.
- Recommendation ITU-T T.800 (2019) | ISO/IEC 15444-1:2019, *Information technology – JPEG 2000 image coding system: Core coding system*.

**1.2.2 Paired Recommendations | International Standards equivalent in technical content**

- Recommendation ITU-T H.264 (2019), *Advanced video coding for generic audiovisual services*.  
ISO/IEC 14496-10:2020, *Information technology – Coding of audio-visual objects – Part 10: Advanced video coding*.
- Recommendation ITU-T H.265 (2019), *High efficiency video coding*.  
ISO/IEC 23008-2:2020, *Information technology – High efficiency coding and media delivery in heterogeneous environments – Part 2: High efficiency video coding*.

- Recommendation. ITU-T H.273 (2021), *Coding-independent code points for video signal type identification*.  
ISO/IEC 23091-2:2021, *Information technology — Coding-independent code points — Part 2: Video*.
- Recommendation ITU-T T.171 (1996), *Protocols for interactive audiovisual services: coded representation of multimedia and hypermedia objects*.  
ISO/IEC 13522-1:1997, *Information technology – Coding of Multimedia and Hypermedia information – Part 1: MHEG object representation – Base notation (ASN.1)*.
- Recommendation ITU-T H.266 (2020), *Versatile video coding*.  
ISO/IEC 23090-3:2021, *Information technology – Coded Representation of Immersive Media – Part 3: Versatile video coding*.
- Recommendation ITU-T H.274 (2020), *Versatile supplemental enhancement information messages for coded video bitstreams*.  
ISO/IEC 23002-7:2021 – *Information Technology – MPEG Video technologies – Part 7: Versatile supplemental enhancement information messages for coded video bitstreams*.

### 1.2.3 Additional references

- Recommendation ITU-R BT.709-6 (2015), *Parameter values for the HDTV standards for production and international programme exchange*.
- Recommendation ITU-R BT.1886 (2011), *Reference electro-optical transfer function for flat panel displays used in HDTV studio production*.
- Recommendation ITU-R BT.2020 (2015), *Parameter values for ultra-high definition television systems for production and international programme exchange*.
- Recommendation ITU-R BT.2100-2 (2018), *Image parameter values for high dynamic range television for use in production and international programme exchange*.
- ISO 639-2:1998, *Codes for the representation of names of languages – Part 2: Alpha-3 code*.
- ISO 8859-1:1998, *Information technology – 8-bit single-byte coded graphic character sets – Part 1: Latin alphabet No. 1*.
- ISO 15706-1:2002, *Information and documentation – International Standard Audiovisual Number (ISAN) – Part 1: Audiovisual work identifier*.
- ISO 15706-2:2007, *Information and documentation – International Standard Audiovisual Number (ISAN) – Part 2: Version identifier*.
- ISO/IEC 11172-1:1993, *Information technology – Coding of moving pictures and associated audio for digital storage media at up to about 1,5 Mbit/s – Part 1: Systems*.
- ISO/IEC 11172-2:1993, *Information technology – Coding of moving pictures and associated audio for digital storage media at up to about 1,5 Mbit/s – Part 2: Video*.
- ISO/IEC 11172-3:1993, *Information technology – Coding of moving pictures and associated audio for digital storage media at up to about 1,5 Mbit/s – Part 3: Audio*.
- ISO/IEC 13818-3:1998, *Information technology – Generic coding of moving pictures and associated audio information – Part 3: Audio*.
- ISO/IEC 13818-6:1998, *Information technology – Generic coding of moving pictures and associated audio information – Part 6: Extensions for DSM-CC*.
- ISO/IEC 13818-7:2006, *Information technology – Generic coding of moving pictures and associated audio information – Part 7: Advanced Audio Coding (AAC)*.
- ISO/IEC 13818-11:2004, *Information technology – Generic coding of moving pictures and associated audio information – Part 11: IPMP on MPEG-2 systems*.
- ISO/IEC 14496-1:2010, *Information technology – Coding of audio-visual objects – Part 1: Systems*.
- ISO/IEC 14496-2:2004, *Information technology – Coding of audio-visual objects – Part 2: Visual*.
- ISO/IEC 14496-3:2019, *Information technology – Coding of audio-visual objects – Part 3: Audio*.
- ISO/IEC 14496-17:2006, *Information technology, Coding of audio-visual objects – Part 17: Streaming text format*.
- ISO/IEC 21122-1:2019, *JPEG XS low-latency lightweight image coding system – Part 1: Core coding system*.

- ISO/IEC 21122-2:2019, *JPEG XS low-latency lightweight image coding system – Part 2: Profiles and buffer models.*
- ISO/IEC 21122-3:2019, *JPEG XS low-latency lightweight image coding system – Part 3: Transport and container formats.*
- ISO/IEC 23001-8:2016, *Information technology – MPEG systems technologies – Part 8: Coding-independent code-points.*
- ISO/IEC 23001-10:2020, *Information technology – MPEG systems technologies – Part 10: Carriage of timed metadata metrics of media in ISO base media file format.*
- ISO/IEC 23001-11:2019, *Information technology – MPEG systems technologies – Part 11: Energy-efficient media consumption (Green Metadata).*
- ISO/IEC 23001-12:2018, *Information technology – MPEG systems technologies – Part 12: Sample Variants.*
- ISO/IEC 23001-13:2019, *Information technology – MPEG systems technologies – Part 13: Media Orchestration.*
- ISO/IEC 23003-3:2020, *Information technology – MPEG audio technologies – Part 3: Unified speech and audio coding.*
- ISO/IEC 23003-4:2020, *Information technology – MPEG audio technologies – Part 4: Dynamic Range Control.*
- ISO/IEC 23008-3:2019, *Information technology – High efficiency coding and media delivery in heterogeneous environments – Part 3: 3D audio.*
- ISO/IEC 23091-2:2019, *Coding-independent code points – Part 2: Video.*
- ISO/IEC 23094-1:2020, *Information technology – General video coding – Part 1: Essential video coding*
- ISO/IEC 23094-2:2021, *Information technology – General video coding – Part 2: Low complexity enhancement video coding.*
- ANSI/SCTE 35 (2019), *Digital Program Insertion Cueing Message for Cable.*
- IETF BCP 47: IETF RFC 4647 (2006) *Matching of Language Tags* combined with IETF RFC 5646 (2009), *Tags for Identifying Languages.*
- IETF RFC 3986 (2005), *Uniform Resource Identifier (URI): Generic Syntax.*
- IETF RFC 5484 (2009), *Associating Time-Codes with RTP Streams.*

## SECTION 2 – TECHNICAL ELEMENTS

## 2.1 Definitions

For the purposes of this Recommendation | International Standard, the following definitions apply. If specific to a Part, this is parenthetically noted.

**2.1.1 access unit (system):** A coded representation of a presentation unit. In the case of audio, an access unit is the coded representation of an audio frame, whereby each audio frame carries data from one or more audio channels; an audio frame may carry for example one mono channel, or two stereo channels or seven surround sound channels.

In the case of video, an access unit includes all the coded data for a picture, and any stuffing that follows it, up to but not including the start of the next access unit. If a picture is not preceded by a `group_start_code` or a `sequence_header_code`, the access unit begins with the picture start code. If a picture is preceded by a `group_start_code` and/or a `sequence_header_code`, the access unit begins with the first byte of the first of these start codes. If it is the last picture preceding a `sequence_end_code` in the bitstream, all bytes between the last byte of the coded picture and the `sequence_end_code` (including the `sequence_end_code`) belong to the access unit.

For the definition of an access unit for Rec. ITU-T H.264 | ISO/IEC 14496-10 video, see the AVC access unit definition in 2.1.3.

In the case of an ISO/IEC 14496-17 text stream, see ISO/IEC 14496-17 for the definition of an access unit.

**2.1.2 AVC 24-hour picture (system):** An advanced video coding (AVC) access unit with a presentation time that is more than 24 hours in the future. For the purpose of this definition, AVC access unit  $n$  has a presentation time that is more than 24 hours in the future if the difference between the initial arrival time  $t_{ai}(n)$  and the DPB output time  $t_{o,dpb}(n)$  is more than 24 hours.

**2.1.3 AVC access unit (system):** An access unit as defined for byte streams in Rec. ITU-T H.264 | ISO/IEC 14496-10 with the constraints specified in 2.14.1.

**2.1.4 AVC slice (system):** A `byte_stream_nal_unit` as defined in Rec. ITU-T H.264 | ISO/IEC 14496-10 with `nal_unit_type` values of 1 or 5, or a `byte_stream_nal_unit` data structure with `nal_unit_type` value of 2 and any associated `byte_stream_nal_unit` data structures with `nal_unit_type` equal to 3 and/or 4.

**2.1.5 AVC still picture (system):** An AVC still picture consists of an AVC access unit containing an IDR picture, preceded by SPS and PPS NAL units that carry sufficient information to correctly decode the IDR picture. Preceding an AVC still picture, there shall be another AVC still picture or an end of sequence NAL unit terminating a preceding coded video sequence unless the AVC still picture is the very first access unit in the video stream.

**2.1.6 AVC video sequence (system):** Coded video sequence as defined in 3.30 of Rec. ITU-T H.264 | ISO/IEC 14496-10.

**2.1.7 AVC video stream (system):** A Rec. ITU-T H.264 | ISO/IEC 14496-10 stream. An AVC video stream consists of one or more AVC video sequences. An AVC video stream may also result from re-assembling video sub-bitstreams.

**2.1.8 AVC video sub-bitstream of MVC:** The video sub-bitstream that contains the base view as defined in Annex H of Rec. ITU-T H.264 | ISO/IEC 14496-10, containing all VCL NAL units associated with the minimum value of view order index present in each AVC video sequence of the AVC video stream. The AVC video sub-bitstream of MVC may additionally contain the associated NAL units with `nal_unit_type` syntax element equal to 14 (prefix NAL units), as defined for MVC in Annex H of Rec. ITU-T H.264 | ISO/IEC 14496-10.

**2.1.9 AVC video sub-bitstream of MVCD:** The video sub-bitstream that contains the base view as defined in Annex I of Rec. ITU-T H.264 | ISO/IEC 14496-10, containing all VCL NAL units associated with the minimum value of view order index present in each AVC video sequence of the AVC video stream. The AVC video sub-bitstream of MVCD may additionally contain the associated NAL units with `nal_unit_type` syntax element equal to 14 (prefix NAL units), as defined for MVC in Annex H of Rec. ITU-T H.264 | ISO/IEC 14496-10.

**2.1.10 AVC video sub-bitstream of SVC:** The video sub-bitstream that contains the base layer as defined in Annex G of Rec. ITU-T H.264 | ISO/IEC 14496-10 and that shall additionally contain NAL units with `nal_unit_type` equal to 14 (prefix NAL units) as defined for scalable video coding (SVC) in Annex G of Rec. ITU-T H.264 | ISO/IEC 14496-10. The AVC video sub-bitstream of SVC contains all VCL NAL units associated with `dependency_id` equal to 0.

**2.1.11 bitrate:** The rate at which the compressed bit stream is delivered from the channel to the input of a decoder.

**2.1.12 byte aligned:** A bit in a coded bit stream is byte-aligned if its position is a multiple of 8-bits from the first bit in the stream.

**2.1.13 channel:** A digital medium that stores or transports a Rec. ITU-T H.222.0 | ISO/IEC 13818-1 stream.

- 2.1.14 coded B-frame:** A B-frame picture or a pair of B-field pictures.
- 2.1.15 coded frame:** A coded frame is a coded I-frame, coded B-frame or a coded P-frame.
- 2.1.16 coded I-frame:** An I-frame picture or a pair of field pictures where the first field picture is an I-picture and the second field picture is either an I-picture or a P-picture.
- 2.1.17 coded P-frame:** A P-frame picture or a pair of P-field pictures.
- 2.1.18 coded representation:** A data element as represented in its encoded form.
- 2.1.19 compression:** Reduction in the number of bits used to represent an item of data.
- 2.1.20 constant bitrate:** Operation where the bitrate is constant from start to finish of the compressed bit stream.
- 2.1.21 constrained system parameter stream (CSPS) (system):** A program stream for which the constraints defined in 2.7.9 apply.
- 2.1.22 cyclic redundancy check (CRC):** The CRC to verify the correctness of data.
- 2.1.23 data element:** An item of data as represented before encoding and after decoding.
- 2.1.24 decoded stream:** The decoded reconstruction of a compressed bit stream.
- 2.1.25 decoder:** An embodiment of a decoding process.
- 2.1.26 decoding (process):** The process defined in this Recommendation | International Standard that reads an input-coded bit stream and outputs decoded pictures or audio samples.
- 2.1.27 decoding time-stamp (DTS) (system):** A field that may be present in a PES packet header that indicates the time that an access unit is decoded in the system target decoder.
- 2.1.28 digital storage media (DSM):** A digital storage or transmission device or system.
- 2.1.29 DSM-CC:** Digital storage media command and control.
- 2.1.30 entitlement control message (ECM):** Entitlement control messages are private conditional access information which specify control words and possibly other, typically stream-specific, scrambling and/or control parameters.
- 2.1.31 entitlement management message (EMM):** Entitlement management messages are private conditional access information which specify the authorization levels or the services of specific decoders. They may be addressed to single decoders or groups of decoders.
- 2.1.32 editing:** The process by which one or more compressed bit streams are manipulated to produce a new compressed bit stream. Edited bit streams meet the same requirements as streams which are not edited.
- 2.1.33 elementary stream (ES) (system):** A generic term for one of the coded video, coded audio or other coded bit streams in PES packets. One elementary stream is carried in a sequence of PES packets with one and only one stream\_id.
- 2.1.34 elementary stream clock reference (ESCR) (system):** A time stamp in the PES stream from which decoders of PES streams may derive timing.
- 2.1.35 encoder:** An embodiment of an encoding process.
- 2.1.36 encoding (process):** A process, not specified in this Recommendation | International Standard, that reads a stream of input pictures or audio samples and produces a coded bit stream conforming to this Recommendation.
- 2.1.37 entropy coding:** Variable length lossless coding of the digital representation of a signal to reduce redundancy.
- 2.1.38 EVC video stream:** A raw bitstream as specified in ISO/IEC 23094-1 Annex B.
- 2.1.39 EVC access unit:** An access unit as defined in ISO/IEC 23094-1 with the constraints specified in 2.24.1.
- 2.1.40 EVC slice:** A slice as specified in ISO/IEC 23094-1.
- 2.1.41 EVC video sequence (system):** coded video sequence as defined in 23094-1.
- 2.1.42 EVC still picture:** an EVC access unit containing an IDR picture, preceded by APS, SPS, PPS and other NAL units that carry sufficient information to correctly decode that picture, and also optionally preceded by another EVC still picture or an end of sequence NAL unit terminating a preceding coded video sequence when the current picture is not the first access unit in the video bitstream.
- 2.1.43 EVC video sub-bitstream:** A subset of the NAL units of an EVC video stream in their original order.

**2.1.44 EVC temporal video sub-bitstream:** An EVC video sub-bitstream that contains all VCL NAL units and associated non-VCL NAL units of the temporal sub-layer, as specified in ISO/IEC 23094-1, associated to TemporalId equal to 0 and which may additionally contain all VCL NAL units and associated non-VCL NAL units of all temporal sub-layers associated to a contiguous range of TemporalId.

**2.1.45 event:** An event is defined as a collection of elementary streams with a common time base, an associated start time, and an associated end time.

**2.1.46 fast forward playback (video):** The process of displaying a sequence, or parts of a sequence, of pictures in display-order faster than real-time.

**2.1.47 forbidden:** The term "forbidden", when used in the clauses of this Recommendation | International Standard defining the coded bit stream, indicates that the value specified shall never be used.

**2.1.48 green access unit** – An access unit that contains dynamic metadata in a message format as defined in 6.2.1 of ISO/IEC 23001-11.

**2.1.49 HEVC 24-hour picture (system):** An HEVC access unit with a presentation time that is more than 24 hours in the future. For the purpose of this definition, HEVC access unit  $n$  has a presentation time that is more than 24 hours in the future if the difference between the initial arrival time  $t_{ai}(n)$  and the DPB output time  $t_{o,dpb}(n)$  is more than 24 hours.

**2.1.50 HEVC access unit:** An access unit as defined in Annex F of Rec. ITU-T H.265 | ISO/IEC 23008-2 with the constraints specified in 2.17.1.

**2.1.51 HEVC base layer:** HEVC layer with `nuh_layer_id` equal to 0.

**2.1.52 HEVC base sub-partition:** HEVC video sub-bitstream that is also a conforming bitstream as specified in Rec. ITU-T H.265 | ISO/IEC 23008-2, which contains all VCL NAL units and the associated non-VCL NAL units of an HEVC base layer up to a target highest TemporalId identified by a target HEVC operation point.

**2.1.53 HEVC complete temporal representation:** A sub-layer representation as defined in Rec. ITU-T H.265 | ISO/IEC 23008-2 that contains all temporal sub-layers up to the temporal sub-layer with TemporalId equal to `sps_max_sub_layers_minus1+1` as included in the active sequence parameter set, as specified in Rec. ITU-T H.265 | ISO/IEC 23008-2.

**2.1.54 HEVC dependent slice segment:** An HEVC slice segment with the syntax element `dependent_slice_segment_flag` in the slice header set to a value equal to 1, as defined in Rec. ITU-T H.265 | ISO/IEC 23008-2.

**2.1.55 HEVC enhancement sub-partition:** One HEVC layer with a particular value of `nuh_layer_id` greater than 0 in the NAL unit header syntax element or an HEVC temporal video sub-bitstream or HEVC temporal video subset thereof, of which the HEVC layer aggregation with an HEVC base sub-partition and zero or more other HEVC sub-partitions, according to HEVC layer list, results in a valid HEVC layered video stream.

**2.1.56 HEVC highest temporal sub-layer representation:** The sub-layer representation of the temporal sub-layer with the highest value of TemporalId, as defined in Rec. ITU-T H.265 | ISO/IEC 23008-2, in the associated HEVC temporal video sub-bitstream or HEVC temporal video subset.

**2.1.57 HEVC independent slice segment:** An HEVC slice segment with the syntax element `dependent_slice_segment_flag` in the slice header set to a value 0 or inferred to be equal to 0, as defined in Rec. ITU-T H.265 | ISO/IEC 23008-2.

**2.1.58 HEVC layer:** HEVC video sub-bitstream that contains all VCL NAL units with a particular value of `nuh_layer_id` in the NAL unit header syntax element and associated non-VCL NAL units, as defined in Annex F of Rec. ITU-T H.265 | ISO/IEC 23008-2.

**2.1.59 HEVC layer aggregation:** Successive HEVC layer component aggregation of all HEVC layer components in an HEVC video sequence.

**2.1.60 HEVC layer component:** VCL NAL units and the associated non-VCL NAL units of an HEVC access unit which belong to an HEVC sub-partition.

**2.1.61 HEVC layer component aggregation:** Concatenation of all HEVC layer components with the same output time from all HEVC sub-partitions indicated in an HEVC layer list in the order indicated by the HEVC layer list, resulting in a valid HEVC access unit as defined in Annex F of Rec. ITU-T H.265 | ISO/IEC 23008-2.

**2.1.62 HEVC layer list:** Ordered list of HEVC sub-partitions for a target HEVC operation point of which the HEVC layer aggregation results in a valid HEVC layered video stream.

NOTE – An HEVC layer list is signalled for each target HEVC operation point using the HEVC operation point descriptor.

**2.1.63 HEVC layered video stream:** HEVC video stream that contains all VCL NAL units and associated non-VCL NAL units conforming to one or more profiles defined in Annex G or Annex H of Rec. ITU-T H.265 | ISO/IEC 23008-2.

**2.1.64 HEVC operation point:** Operation point based on a target highest TemporalId, and a target layer identifier list as specified in Rec. ITU-T H.265 | ISO/IEC 23008-2.

NOTE – Rec. ITU-T H.265 | ISO/IEC 23008-2 specifies the sub-bitstream extraction process for an operation point according to which the operation point is a conforming bitstream. An operation point is associated with an HEVC layered video stream or HEVC base layer.

**2.1.65 HEVC slice:** An HEVC independent slice segment and zero or more subsequent HEVC dependent slice segments preceding the next HEVC independent slice segment (if any) within the same HEVC access unit.

**2.1.66 HEVC slice segment:** A byte\_stream\_nal\_unit with nal\_unit\_type in the range of 0 to 9 and 16 to 23, as defined in Rec. ITU-T H.265 | ISO/IEC 23008-2.

**2.1.67 HEVC still picture (system):** An HEVC still picture consists of an HEVC access unit containing an IDR picture preceded by VPS, SPS and PPS NAL units, as defined in Rec. ITU-T H.265 | ISO/IEC 23008-2, that carry sufficient information to correctly decode this IDR picture. Preceding an HEVC still picture, there shall be another HEVC still picture or an end of sequence NAL unit terminating a preceding coded video sequence, as defined in Rec. ITU-T H.265 | ISO/IEC 23008-2.

**2.1.68 HEVC sub-partition:** Either an HEVC base sub-partition or an HEVC enhancement sub-partition.

NOTE – An HEVC sub-partition can either be an HEVC temporal video sub-bitstream if it includes VCL NAL units with the minimum value of TemporalId (i.e., including TemporalId equal to 0), or it can be an HEVC temporal video subset, if it complements an HEVC base sub-partition or HEVC enhancement sub-partition with the same target layer identifier.

**2.1.69 HEVC temporal enhancement sub-partition:** An HEVC temporal video subset of the same HEVC layer as another HEVC enhancement sub-partition of the same HEVC video stream which contains one or more complementary temporal sub-layers, as specified in Rec. ITU-T H.265 | ISO/IEC 23008-2.

**2.1.70 HEVC temporal video sub-bitstream:** An HEVC video sub-bitstream that contains all VCL NAL units and associated non-VCL NAL units of the temporal sub-layer of the same layer, as specified in Rec. ITU-T H.265 | ISO/IEC 23008-2, associated with TemporalId equal to 0 and which may additionally contain all VCL NAL units and associated non-VCL NAL units of all temporal sub-layers of the same layer associated with a contiguous range of TemporalId from 1 to a value equal to or smaller than sps\_max\_sub\_layers\_minus1 included in the active sequence parameter set, as specified in Rec. ITU-T H.265 | ISO/IEC 23008-2.

**2.1.71 HEVC temporal video subset:** An HEVC video sub-bitstream that contains all VCL NAL units and the associated non-VCL NAL units of one or more temporal sub-layers of the same layer, as specified in Rec. ITU-T H.265 | ISO/IEC 23008-2, with each temporal sub-layer not being present in the corresponding HEVC temporal video sub-bitstream and TemporalId associated with each temporal sub-layer forming a contiguous range of values that is equal to or smaller than sps\_max\_sub\_layers\_minus1 included in the active sequence parameter set, as specified in Rec. ITU-T H.265 | ISO/IEC 23008-2.

NOTE – According to the constraints for the transport of HEVC specified in 2.17.1, each temporal sub-layer of an *HEVC video stream* is present either in the HEVC temporal video sub-bitstream or in exactly one HEVC temporal video subset which is carried in a set of elementary streams that are associated by hierarchy descriptors or HEVC hierarchy extension descriptors. This prevents multiple inclusions of the same temporal sub-layer and allows aggregation of the HEVC temporal video sub-bitstream with associated HEVC temporal video subsets according to the hierarchy descriptors, as specified in 2.17.3 and according to the hierarchy descriptors or HEVC hierarchy extension descriptors, as specified in 2.17.4.

**2.1.72 HEVC tile of slices:** One or more consecutive HEVC slices which form the coded representation of a tile, as defined in Rec. ITU-T H.265 | ISO/IEC 23008-2.

**2.1.73 HEVC tile substream:** Substream of a Rec. ITU-T H.265 | ISO/IEC 23008 2 video stream that contains a Motion Constrained Tile Set, parameter sets, slice headers or a combination thereof.

**2.1.74 HEVC video sequence (system):** A coded video sequence as defined in Rec. ITU-T H.265 | ISO/IEC 23008-2.

**2.1.75 HEVC video stream:** Byte stream as specified in Rec. ITU-T H. 265 | ISO/IEC 23008-2 Annex B.

NOTE – This term represents either a byte stream as specified in Annex B of the first version of Rec. ITU-T H.265 | ISO/IEC 23008-2 or an HEVC layered video sub-bitstream.

**2.1.76 HEVC video sub-bitstream:** A subset of the NAL units of an HEVC video stream in their original order.

**2.1.77 JPEG 2000 (J2K) video access unit:** The JPEG 2000 codestream or codestreams comprising a decodable and randomly accessible (portion of) image, preceded by all the parameters required to decode the access unit and display the decoded data.

- 2.1.78 J2K block:** The JPEG 2000 codestream or codestreams corresponding to a rectangular portion of a video frame, as detailed in S.3.
- NOTE – Usage of J2K blocks requires J2K block mode (defined in 2.1.79)
- 2.1.79 J2K block mode:** Optional mode defined in S.3, dividing each frame of a J2K video stream in a certain amount of rectangular blocks, each encoded as an independent J2K block (defined in 2.1.78).
- 2.1.80 J2K still picture (system):** J2K video access unit as defined in 2.1.87 with constraints as specified in S.2.
- 2.1.81 J2K stripe:** The JPEG 2000 codestream or codestreams comprising a decodable horizontally divided portion of an image, as detailed in S.4.
- NOTE – Usage of J2K stripes requires J2K stripe mode (defined in 2.1.82) to be enabled in the J2K video descriptor. Such usage enables transport of a J2K video stream with a low end-to-end latency.
- 2.1.82 J2K stripe mode:** Optional mode defined in S.4, dividing the (portion of) image transported in a J2K video access unit in a succession of horizontal stripes, each encoded as an independent J2K stripe (defined in 2.1.81).
- 2.1.83 J2K video elementary stream:** Video elementary stream consisting of a succession of J2K video access units.
- 2.1.84 J2K video sequence:** J2K video elementary stream where all the access units have the same profile/level, J2K video access unit coding parameters and video parameters.
- 2.1.85 JPEG XS elementary stream header (jxes header):** All parameters required to decode a JPEG XS video access unit and display the decoded data.
- 2.1.86 JPEG XS still picture (system):** JPEG XS video access unit as defined in 2.1.87 with constraints as specified in W.2.
- 2.1.87 JPEG XS video access unit:** The JPEG XS codestream or multiple JPEG XS codestreams, as defined in ISO/IEC 21122-1, comprising a decodable and randomly accessible image, preceded by a JPEG XS elementary stream header.
- 2.1.88 JPEG XS video elementary stream:** Video elementary stream consisting of a succession of JPEG XS video access units.
- 2.1.89 JPEG XS video sequence:** JPEG XS video elementary stream where all the access units have the same profile, level and sublevel (as defined in ISO/IEC 21122-2), JPEG XS video access unit coding parameters, and video parameters.
- 2.1.90 layer (video and systems):** One of the levels in the data hierarchy of the video and system specifications defined in Parts 1 and 2 of this Recommendation | International Standard.
- 2.1.91 LCEVC access unit (system):** An access unit as defined for byte streams in ISO/IEC 23094-2 with the constraints specified in 2.25.1.
- 2.1.92 LCEVC video sequence (system):** Coded video sequence as defined in ISO/IEC 23094-2.
- 2.1.93 MCTS:** Motion Constrained Tile Set according to Rec. ITU-T H.265 | ISO/IEC 23008-2.
- 2.1.94 metadata:** Information to describe audiovisual content and data essence in a format defined by ISO or any other authority.
- 2.1.95 metadata access unit:** A global structure within metadata that defines the fraction of metadata that is intended to be decoded at a specific instant in time. The internal structure of a metadata Access Unit is defined by the format of the metadata.
- 2.1.96 metadata application format:** Identifies the format of the application that uses the metadata; signals application specific information for transport of metadata.
- 2.1.97 metadata decoder configuration information:** Data needed by a receiver to decode a specific metadata service. Depending on the format of the metadata, decoder configuration information may or may not be needed.
- 2.1.98 metadata format:** Identifies the coding format of metadata.
- 2.1.99 metadata service:** A coherent set of metadata of the same format delivered to a receiver for a specific purpose.
- 2.1.100 metadata service id:** Identifier of a specific metadata service; used for some transport methods of the metadata.
- 2.1.101 metadata stream:** The concatenation or collection of metadata Access Units from one or more metadata services.
- 2.1.102 (multiplexed) stream (system):** A bit stream composed of 0 or more elementary streams combined in a manner that conforms to this Recommendation | International Standard.

**2.1.103 MVC base view sub-bitstream:** The MVC base view sub-bitstream is defined to contain the AVC video sub-bitstream of MVC conforming to one or more profiles defined in Annex H of Rec. ITU-T H.264 | ISO/IEC 14496-10 and one additional MVC video sub-bitstream associated with an MVC view\_id subset including the view order index that immediately follows the view order index associated with the base view.

NOTE – The MVC base view sub-bitstream is also an AVC video stream where no re-assembly is required before decoding.

**2.1.104 MVC operation point:** An MVC operation point is identified by a temporal\_id value representing a target temporal level and a set of view\_id values representing the target output views. One MVC operation point is associated with an AVC video stream which conforms to one or more profiles defined in Annex H of Rec. ITU-T H.264 | ISO/IEC 14496-10. The AVC video stream associated with an MVC operation point is re-assembled from a set consisting of one or more of the following items: AVC video sub-bitstream of MVC, MVC base view sub-bitstream, MVC video sub-bitstreams.

**2.1.105 MVC slice (system):** A byte\_stream\_nal\_unit with nal\_unit\_type syntax element equal to 20 of an AVC video stream which conforms to one or more profiles defined in Annex H of Rec. ITU-T H.264 | ISO/IEC 14496-10.

NOTE – As specified in Rec. ITU-T H.264 | ISO/IEC 14496-10, the value of svc\_extension\_flag is set equal to 0 for coded video sequences conforming to one or more profiles specified in Annex H. MVC slices should not include NAL units for which nal\_unit\_type is equal to 20 with svc\_extension\_flag equal to 1.

**2.1.106 MVC video sub-bitstream:** The MVC video sub-bitstream is defined to be all VCL NAL units with nal\_unit\_type equal to 20 associated with the same multiview video coding (MVC) view\_id subset of an advanced video coding (AVC) video stream and associated non-VCL NAL units which conform to one or more profiles defined in Annex H of Rec. ITU-T H.264 | ISO/IEC 14496-10.

NOTE – In contrast to a sub-bitstream as specified in Annex H of Rec. ITU-T H.264 | ISO/IEC 14496-10, an MVC video sub-bitstream according to this Specification is not necessarily a decodable MVC video sub-bitstream. The one exception is when an MVC video sub-bitstream is also an MVC base view sub-bitstream. Re-assembling MVC video sub-bitstreams in an increasing order of view order index, starting from the lowest value of view order index up to any value of view order index, results in a decodable AVC video stream.

**2.1.107 MVC view\_id subset:** A set of one or more view\_id values, as defined in Annex H of Rec. ITU-T H.264 | ISO/IEC 14496-10 in the NAL unit header syntax element, associated with one set of consecutive view order index values.

NOTE – An MVC video sub-bitstream or MVC base view sub-bitstream based on a specific MVC view\_id subset may not include view components for all view\_id values included in that MVC view\_id subset. One or more view order index values may be skipped if the view associated with a missing view order index value is not required for decoding the transmitted views.

**2.1.108 MVCD base view sub-bitstream:** The MVCD base view sub-bitstream is defined to contain the AVC video sub-bitstream of MVCD conforming to one or more profiles defined in Annex I of Rec. ITU-T H.264 | ISO/IEC 14496-10 and one additional MVCD video sub-bitstream associated with an MVCD view\_id subset including the view order index that immediately follows the view order index associated with the base view.

NOTE – The MVCD base view sub-bitstream is also an AVC video stream where no re-assembly is required before decoding.

**2.1.109 MVCD slice (system):** A byte\_stream\_nal\_unit with nal\_unit\_type syntax element equal to 21 of an AVC video stream which conforms to one or more profiles defined in Annex I of Rec. ITU-T H.264 | ISO/IEC 14496-10.

**2.1.110 MVCD video sub-bitstream:** The MVCD video sub-bitstream is defined to be all VCL NAL units with nal\_unit\_type equal to 21 associated with the same MVCD view\_id subset of an AVC video stream and associated non-VCL NAL units which conform to one or more profiles defined in Annex I of Rec. ITU-T H.264 | ISO/IEC 14496-10.

NOTE – In contrast to a sub-bitstream as specified in Annex I of Rec. ITU-T H.264 | ISO/IEC 14496-10, an MVCD video sub-bitstream according to this Specification is not necessarily a decodable MVCD video sub-bitstream. The one exception is when an MVCD video sub-bitstream is also an MVCD base view sub-bitstream. Re-assembling MVCD video sub-bitstreams in an increasing order of view order index, starting from the lowest value of view order index up to any value of view order index, results in a decodable AVC video stream.

**2.1.111 MVC view-component subset:** The VCL NAL units of an AVC access unit associated with the same MVC view\_id subset and associated non-VCL NAL units.

NOTE – Re-assembling MVC view-component subsets ordered according to the view order index, starting from the minimum view order index up to the highest view order index present in the access unit, while reordering the non-VCL NAL units conforming to the order of NAL units within an access unit, as defined in Rec. ITU-T H.264 | ISO/IEC 14496-10, results in an AVC access unit.

**2.1.112 MVCD view-component subset:** The VCL NAL units of an AVC access unit associated with the same MVCD view\_id subset and associated non-VCL NAL units.

NOTE – Re-assembling MVCD view-component subsets ordered according to the view order index, starting from the minimum view order index up to the highest view order index present in the access unit, while reordering the non-VCL NAL units conforming to the order of NAL units within an access unit, as defined in Rec. ITU-T H.264 | ISO/IEC 14496-10, results in an AVC access unit.

**2.1.113 MVCD view\_id subset:** A set of one or more view\_id values, as defined in Annex I of Rec. ITU-T H.264 | ISO/IEC 14496-10 in the NAL unit header syntax element, associated with one set of consecutive view order index values.

NOTE – An MVCD video sub-bitstream or MVCD base view sub-bitstream based on a specific MVCD view\_id subset may not include view components for all view\_id values included in that MVCD view\_id subset. One or more view order index values may be skipped if the view associated with a missing view order index value is not required for decoding the transmitted views.

**2.1.114 pack (system):** A pack consists of a pack header followed by zero or more packets. It is a layer in the system coding syntax described in 2.5.3.3.

**2.1.115 packet data (system):** Contiguous bytes of data from an elementary stream present in a packet.

**2.1.116 packet identifier (PID) (system):** A unique integer value used to identify elementary streams of a program in a single or multi-program transport stream as described in 2.4.3.

**2.1.117 padding (audio):** A method to adjust the average length of an audio frame in time to the duration of the corresponding PCM samples, by conditionally adding a slot to the audio frame.

**2.1.118 payload:** Payload refers to the bytes which follow the header bytes in a packet. For example, the payload of some transport stream packets includes a PES\_packet\_header and its PES\_packet\_data\_bytes, or pointer\_field and PSI sections, or private data; but a PES\_packet\_payload consists of only PES\_packet\_data\_bytes. The transport stream packet header and adaptation fields are not payload.

**2.1.119 PES (system):** An abbreviation for a Packetized Elementary Stream.

**2.1.120 PES packet (system):** The data structure used to carry elementary stream data. A PES packet consists of a PES packet header followed by a number of contiguous bytes from an elementary data stream. It is a layer in the system coding syntax described in 2.4.3.6.

**2.1.121 PES packet header (system):** The leading fields in a PES packet up to and not including the PES\_packet\_data\_byte fields, where the stream is not a padding stream. In the case of a padding stream the PES packet header is similarly defined as the leading fields in a PES packet up to and not including padding\_byte fields.

**2.1.122 packetized elementary stream (PES) (system):** A PES system consists of PES packets, all of whose payloads consist of data from a single elementary stream, and all of which have the same stream\_id. Specific semantic constraints apply. Refer to Intro. 4.

**2.1.123 presentation time-stamp (PTS) (system):** A field that may be present in a PES packet header that indicates the time that a presentation unit is presented in the system target decoder.

**2.1.124 presentation unit (PU) (system):** A decoded audio access unit or a decoded picture.

**2.1.125 program (system):** A program is a collection of program elements. Program elements may be elementary streams. Program elements need not have any defined time base; those that do, have a common time base and are intended for synchronized presentation.

**2.1.126 program clock reference (PCR) (system):** A time stamp in the transport stream from which decoder timing is derived.

**2.1.127 program element (system):** A generic term for one of the elementary streams or other data streams that may be included in a program.

**2.1.128 program-specific information (PSI) (system):** PSI consists of normative data which is necessary for the demultiplexing of transport streams and the successful regeneration of programs and is described in 2.4.4.1. An example of privately defined PSI data is the non-mandatory network information table.

**2.1.129 quality access unit:** An access unit that contains dynamic quality metadata as defined in ISO/IEC 23001-10.

**2.1.130 random access:** The process of beginning to read and decode the coded bit stream at an arbitrary point.

**2.1.131 reserved:** The term "reserved", when used in the clauses defining the coded bit stream, indicates that the value may be used in the future for ISO defined extensions. Unless otherwise specified within this Recommendation | International Standard, all reserved bits shall be set to '1'.

**2.1.132 sample variant:** An assembled media sample replacing an original sample as defined in ISO/IEC 23001-12:2018.

NOTE – In ISO/IEC 23001-12:2018, the term “sample” is used commonly for samples as defined in ISO Base Media File Format (ISO/IEC 14496-12) and for access units as defined in 2.1.1.

**2.1.133 scrambling (system):** The alteration of the characteristics of a video, audio or coded data stream in order to prevent unauthorized reception of the information in a clear form. This alteration is a specified process under the control of a conditional access system.

**2.1.134 service-compatible:** This is defined as 'simulcast' of two stereoscopic views which do not include scalable or temporal coding. The two views are independently compressed using MPEG-2 video or AVC or both and can be decoded independently.

**2.1.135 source stream:** A single non-multiplexed stream of samples before compression coding.

**2.1.136 splicing (system):** The concatenation, performed on the system level, of two different elementary streams. The resulting system stream conforms totally to this Recommendation | International Standard. The splice may result in discontinuities in time base, continuity counter, PSI, and decoding.

**2.1.137 start codes (system):** 32-bit codes embedded in the coded bit stream. They are used for several purposes including identifying some of the layers in the coding syntax. Start codes consist of a 24-bit prefix (0x000001) and an 8-bit stream\_id as shown in Table 2-22.

**2.1.138 STD input buffer (system):** A first-in first-out buffer at the input of a system target decoder for storage of compressed data from elementary streams before decoding.

**2.1.139 still picture:** A still picture consists of a video sequence, coded as defined in Rec. ITU-T H.262 | ISO/IEC 13818-2, ISO/IEC 11172-2 or ISO/IEC 14496-2, that contains exactly one coded picture which is intra-coded. This picture has an associated PTS and in case of coding according to ISO/IEC 11172-2, Rec. ITU-T H.262 | ISO/IEC 13818-2 or ISO/IEC 14496-2, the presentation time of succeeding pictures, if any, is later than that of the still picture by at least two picture periods.

**2.1.140 SVC dependency representation:** The VCL NAL units of an AVC access unit associated with the same value of dependency\_id which is provided as part of the NAL unit header or the associated prefix NAL unit header, and the associated non-VCL NAL units. Re-assembling SVC dependency representations in a consecutive order of dependency\_id starting from the lowest value of dependency\_id present in the access unit up to any value of dependency\_id present in the access unit, while reordering the non-VCL NAL units conforming to the order of NAL units within an access unit as defined in Rec. ITU-T H.264 | ISO/IEC 14496-10, results in an AVC access unit.

**2.1.141 SVC slice (system):** A byte\_stream\_nal\_unit as defined in Rec. ITU-T H.264 | ISO/IEC 14496-10 with nal\_unit\_type equal to 20 of an AVC video stream which conforms to one or more profiles defined in Annex G of Rec. ITU-T H.264 | ISO/IEC 14496-10.

NOTE – As specified in Rec. ITU-T H.264 | ISO/IEC 14496-10, the value of svc\_extension\_flag is set equal to 1 for coded video sequences conforming to one or more profiles specified in Annex G. SVC slices should not include NAL units for which nal\_unit\_type is equal to 20 with svc\_extension\_flag equal to 0.

**2.1.142 SVC video sub-bitstream:** The video sub-bitstream that contains VCL NAL units with nal\_unit\_type equal to 20 with the same NAL unit header syntax element dependency\_id not equal to 0.

**2.1.143 system header (system):** The system header is a data structure defined in 2.5.3.5 that carries information summarizing the system characteristics of Rec. ITU-T H.222.0 | ISO/IEC 13818-1 program stream.

**2.1.144 system clock reference (SCR) (system):** A time stamp in the program stream from which decoder timing is derived.

**2.1.145 system target decoder (STD) (system):** A hypothetical reference model of a decoding process used to define the semantics of a Rec. ITU-T H.222.0 | ISO/IEC 13818-1 multiplexed bit stream.

**2.1.146 time-stamp (system):** A term that indicates the time of a specific action such as the arrival of a byte or the presentation of a Presentation Unit.

**2.1.147 transport stream packet header (system):** The leading fields in a transport stream packet, up to and including the continuity\_counter field.

**2.1.148 variable bitrate:** An attribute of transport streams or program streams wherein the rate of arrival of bytes at the input to a decoder varies with time.

**2.1.149 video sub-bitstream:** A video sub-bitstream is defined to be all VCL NAL units associated with the same value of dependency\_id of an AVC video stream which conforms to one or more profiles defined in Annex G of Rec. ITU-T H.264 | ISO/IEC 14496-10 and all associated non-VCL NAL units in decoding order as defined in Rec. ITU-T H.264 | ISO/IEC 14496-10. Re-assembling video sub-bitstreams in a consecutive order of dependency\_id, starting from the dependency\_id equal to 0 up to any value of dependency\_id, results in an AVC video stream. A video sub-bitstream shall have the AVC byte stream format as defined in Annex B of Rec. ITU-T H.264 | ISO/IEC 14496-10.

**2.1.150 view order index:** An index that indicates the decoding order of MVC view components in an AVC access unit as defined in Annex H of Rec. ITU-T H.264 | ISO/IEC 14496-10 or MVCD view components in an AVC access unit as defined in Annex I of Rec. ITU-T H.264 | ISO/IEC 14496-10. The association of view order index values to the NAL unit header syntax element view\_id is indicated for an AVC video sequence in the sequence parameter set MVC extension as

defined in Annex H of Rec. ITU-T H.264 | ISO/IEC 14496-10 or in the sequence parameter set MVCD extension as defined in Annex I of Rec. ITU-T H.264 | ISO/IEC 14496-10.

**2.1.151 VVC video stream:** A byte stream as specified in Rec. ITU-T H.266 | ISO/IEC 23090-3 Annex B.

**2.1.152 VVC access unit:** An access unit as defined in Rec. ITU-T H.266 | ISO/IEC 23090-3 with the constraints specified in 2.23.1.

**2.1.153 VVC 24-hour picture (system):** A VVC access unit with a presentation time that is more than 24 hours in the future. For the purpose of this definition, VVC access unit  $n$  has a presentation time that is more than 24 hours in the future if the difference between the initial arrival time  $t_{ai}(n)$  and the DPB output time  $t_{o,dpb}(n)$  is more than 24 hours.

**2.1.154 VVC slice:** A slice as specified in Rec. ITU-T H.266 | ISO/IEC 23090-3.

**2.1.155 VVC subpicture:** A subpicture as specified in Rec. ITU-T H.266 | ISO/IEC 23090-3.

**2.1.156 VVC tile of slices:** One or more consecutive VVC slices which form the coded representation of a tile as defined in Rec. ITU-T H.266 | ISO/IEC 23090-3.

**2.1.157 VVC still picture (system):** A VVC still picture consists of a VVC access unit containing an IDR picture preceded by VPS, SPS and PPS NAL units, as defined in Rec. ITU-T H.266 | ISO/IEC 23090-3, that carry sufficient information to correctly decode this IDR picture. Preceding a VVC still picture, there shall be another VVC still picture or an End of Sequence NAL unit terminating a preceding coded video sequence as defined in Rec. ITU-T H.266 | ISO/IEC 23090-3.

**2.1.158 VVC video sequence (system):** coded video sequence as defined in Rec. ITU-T H.266 | ISO/IEC 23090-3.

**2.1.159 VVC video sub-bitstream:** A subset of the NAL units of a VVC video stream in their original order.

**2.1.160 VVC temporal video sub-bitstream:** A VVC video sub-bitstream that contains all VCL NAL units and associated non-VCL NAL units of the temporal sublayer, as specified in Rec. ITU-T H.266 | ISO/IEC 23090-3, associated to TemporalId equal to 0 and which may additionally contain all VCL NAL units and associated non-VCL NAL units of all temporal sublayers associated to a contiguous range of TemporalId from 1 to a value equal to or smaller than  $sps\_max\_sublayers\_minus1$  included in the referred sequence parameter set, as specified in Rec. ITU-T H.266 | ISO/IEC 23090-3.

**2.1.161 VVC temporal video subset:** A VVC video sub-bitstream that contains all VCL NAL units and the associated non-VCL NAL units of one or more temporal sublayers, as specified in Rec. ITU-T H.266 | ISO/IEC 23090-3, with each temporal sublayer not being present in the corresponding VVC temporal video sub-bitstream and TemporalId associated with each temporal sublayer forming a contiguous range of values.

NOTE – According to the constraints for the transport of VVC specified in 2.23.1, each temporal sublayer of a VVC video stream is present either in the VVC temporal video sub-bitstream or in exactly one VVC temporal video subset which are carried in a set of elementary streams that are associated by hierarchy descriptors. This prevents multiple inclusion of the same temporal sublayer and allows aggregation of the VVC temporal video sub-bitstream with associated VVC temporal video subsets according to the hierarchy descriptors as specified in 2.23.3.

**2.1.162 VVC highest temporal sublayer representation:** The sublayer representation of the temporal sublayer with the highest value of TemporalId, as defined in Rec. ITU-T H.266 | ISO/IEC 23090-3, in the associated VVC temporal video sub-bitstream or VVC temporal video subset.

**2.1.163 VVC complete temporal representation:** A sublayer representation as defined in Rec. ITU-T H.266 | ISO/IEC 23090-3 that contains all temporal sublayers up to the temporal sublayer with TemporalId equal to  $sps\_max\_sublayers\_minus1$  as included in the referred sequence parameter set, as specified in Rec. ITU-T H.266 | ISO/IEC 23090-3.

## 2.2 Symbols and abbreviations

The mathematical operators used to describe this Recommendation | International Standard are similar to those used in the C-programming language. However, integer division with truncation and rounding are specifically defined. The bitwise operators are defined assuming two's-complement representation of integers. Numbering and counting loops generally begin from 0.

### 2.2.1 Arithmetic operators

+	Addition
–	Subtraction (as a binary operator) or negation (as a unary operator)
++	Increment
--	Decrement

* or ×	Multiplication
^	Power
/	Integer division with truncation of the result toward 0. For example, 7/4 and -7/-4 are truncated to 1 and -7/4 and 7/-4 are truncated to -1.
//	Integer division with rounding to the nearest integer. Half-integer values are rounded away from 0 unless otherwise specified. For example 3//2 is rounded to 2, and -3//2 is rounded to -2.
DIV	Integer division with truncation of the result towards $-\infty$ .
%	Modulus operator. Defined only for positive numbers.
Sign()	$\text{Sign}(x) = \begin{cases} 1 & x > 0 \\ 0 & x = 0 \\ -1 & x < 0 \end{cases}$
NINT()	Nearest integer operator. Returns the nearest integer value to the real-valued argument. Half-integer values are rounded away from 0.
sin	Sine
cos	Cosine
exp	Exponential
√	Square root
log <sub>10</sub>	Logarithm to base ten
log <sub>e</sub>	Logarithm to base e

### 2.2.2 Assignment

= Assignment operator

### 2.2.3 Bitwise operators

& AND  
 | OR  
 >> Shift right with sign extension  
 << Shift left with 0 fill

### 2.2.4 Constants

π 3.14159265359  
 e 2.71828182845

### 2.2.5 Logical operators

|| Logical OR  
 && Logical AND  
 ! Logical NOT

### 2.2.6 Mnemonics

The following mnemonics are defined to describe the different data types used in the coded bit-stream.

bslbf Bit string, left bit first, where "left" is the order in which bit strings are written in this Recommendation | International Standard. Bit strings are written as a string of 1s and 0s within single quote marks, e.g., '1000 0001'. Blanks within a bit string are for ease of reading and have no significance.

NOTE – In some tables of this specification, two bit strings are used to define a range of values. In other tables, bit strings are used to specify integer values. In these cases, each bit string is equivalent to a binary number of which the least significant bit (unity position) equals the rightmost bit of the bit string and the significance of bits increases from right to left.

ch Channel  
 gr Granule of 3 \* 32 sub-band samples in audio Layer II, 18 \* 32 sub-band samples in audio Layer III.  
 main\_data The main\_data portion of the bit stream contains the scale factors, Huffman encoded data, and ancillary information.

main_data_beg	This gives the location in the bit stream of the beginning of the main_data for the frame. The location is equal to the ending location of the previous frame's main_data plus 1 bit. It is calculated from the main_data_end value of the previous frame.
part2_length	This value contains the number of main_data bits used for scale factors.
rpchof	Remainder polynomial coefficients, highest order first
sb	Sub-band
scfsi	Scalefactor selector information
switch_point_l	Number of scalefactor band (long block scalefactor band) from which point on window switching is used
switch_point_s	Number of scalefactor band (short block scalefactor band) from which point on window switching is used
tcimbsf	Two's complement integer, msb (sign) bit first
uimbsf	Unsigned integer, most significant bit first
vlclbf	Variable length code, left bit first, where "left" refers to the order in which the variable length codes are written
window	Number of actual time slot in case of block_type == 2, $0 \leq \text{window} \leq 2$ .

The byte order of multi-byte words is most significant byte first.

### 2.2.7 Range operator

.. Range operator. n .. m defines the inclusive range of numbers from n up to m

### 2.2.8 Relational operators

> Greater than

≥ Greater than or equal to

< Less than

≤ Less than or equal to

== Equal to

!= Not equal to

max [,...] The maximum value in the argument list

min [,...] The minimum value in the argument list

## 2.3 Method of describing bit stream syntax

The bit streams retrieved by the decoder are described in 2.4.1 and 2.5.1. Each data item in the bit stream is in bold type. It is described by its name, its length in bits, and a mnemonic for its type and order of transmission.

The action caused by a decoded data element in a bit stream depends on the value of that data element and on data elements previously decoded. The decoding of the data elements and definition of the state variables used in their decoding are described in the clauses containing the semantic description of the syntax. The following constructs are used to express the conditions when data elements are present, and are in normal type.

Note this syntax uses the "C"-code convention that a variable or expression evaluating to a non-zero value is equivalent to a condition that is true:

```
while ( condition ) {
    data_element
    ...
}
do {
    data_element
    ...
}
while ( condition )
```

If the condition is true, then the group of data elements occurs next in the data stream. This repeats until the condition is not true.

The data element always occurs at least once. The data element is repeated until the condition is not true.

if ( condition ) { <b>data_element</b> ... }	If the condition is true, then the first group of data elements occurs next in the data stream.
else { <b>data_element</b> ... }	If the condition is not true, then the second group of data elements occurs next in the data stream.
for ( i = 0; i < n; i++ ) { <b>data_element</b> ... }	The group of data elements occurs n times. Conditional constructs within the group of data elements may depend on the value of the loop control variable i, which is set to zero for the first occurrence, incremented to 1 for the second occurrence, and so forth.

As noted, the group of data elements may contain nested conditional constructs. For compactness, the {} are omitted when only one data element follows:

<b>data_element</b> []	<code>data_element []</code> is an array of data. The number of data elements is indicated by the context.
<b>data_element</b> [n]	<code>data_element [n]</code> is the n+1th element of an array of data.
<b>data_element</b> [m][n]	<code>data_element [m][n]</code> is the m+1,n+1th element of a two-dimensional array of data.
<b>data_element</b> [l][m][n]	<code>data_element [l][m][n]</code> is the l+1,m+1,n+1th element of a three-dimensional array of data.
<b>data_element</b> [m..n]	is the inclusive range of bits between bit m and bit n in the <code>data_element</code> .

While the syntax is expressed in procedural terms, it should not be assumed that either Figure 2-1 or Figure 2-2 implements a satisfactory decoding procedure. In particular, they define a correct and error-free input bitstream. Actual decoders must include a means to look for start codes and sync bytes (transport stream) in order to begin decoding correctly, and to identify errors, erasures or insertions while decoding. The methods to identify these situations, and the actions to be taken, are not standardized.

## 2.4 Transport stream bitstream requirements

### 2.4.1 Transport stream coding structure and parameters

The Rec. ITU-T H.222.0 | ISO/IEC 13818-1 transport stream coding layer allows one or more programs to be combined into a single stream. Data from each elementary stream are multiplexed together with information that allows synchronized presentation of the elementary streams within a program.

A transport stream consists of one or more programs. Audio and video elementary streams consist of access units.

Elementary stream data is carried in PES packets. A PES packet consists of a PES packet header followed by packet data. PES packets are inserted into transport stream packets. The first byte of each PES packet header is located at the first available payload location of a transport stream packet.

The PES packet header begins with a 32-bit start-code that also identifies the stream or stream type to which the packet data belongs. The PES packet header may contain decoding and presentation time stamps (DTS and PTS). The PES packet header also contains other optional fields. The PES packet data field contains a variable number of contiguous bytes from one elementary stream.

Transport stream packets begin with a 4-byte prefix, which contains a 13-bit packet ID (PID), defined in Table 2-2. The PID identifies, via the program-specific information (PSI) tables, the contents of the data contained in the transport stream packet. Transport stream packets of one PID value carry data of one and only one elementary stream.

The PSI tables are carried in the transport stream. There are six PSI tables:

- Program association table (PAT);
- Program map table (PMT);
- Conditional access table (CAT);
- Network information table (NIT);
- Transport stream description table (TSDT);
- IPMP control information table.

These tables contain the necessary and sufficient information to demultiplex and present programs. The program map table in Table 2-33 specifies, among other information, which PIDs, and therefore which elementary streams, are associated to form each program. This table also indicates the PID of the transport stream packets which carry the PCR for each program. The conditional access table shall be present if scrambling is employed. The network information table is optional and its contents are not specified by this Recommendation | International Standard. The IPMP control information table shall be present if IPMP as described in ISO/IEC 13818-11 is used by any of the components in the Rec. ITU-T H.222.0 | ISO/IEC 13818-1 stream.

Transport stream packets may be null packets. Null packets are intended for padding of transport streams. They may be inserted or deleted by re-multiplexing processes and, therefore, the delivery of the payload of null packets to the decoder cannot be assumed.

This Recommendation | International Standard does not specify the coded data which may be used as part of conditional access systems. This Specification does, however, provide mechanisms for program service providers to transport and identify this data for decoder processing, and to reference correctly data which are specified by this Specification. This type of support is provided both through transport stream packet structures and in the conditional access table (refer to Table 2-32).

**2.4.2 Transport stream system target decoder**

**2.4.2.1 General**

The semantics of the transport stream specified in 2.4.3 and the constraints on these semantics specified in 2.7 require exact definitions of byte arrival and decoding events and the times at which these occur. The definitions needed are set out in this Recommendation | International Standard using a hypothetical decoder known as the transport stream system target decoder (T-STD). Informative Annex D contains further explanation of the T-STD.

The T-STD is a conceptual model used to define these terms precisely and to model the decoding process during the construction or verification of transport streams. The T-STD is defined only for this purpose. There are three types of decoders in the T-STD: video, audio, and systems. Figure 2-1 illustrates an example. Neither the architecture of the T-STD nor the timing described precludes uninterrupted, synchronized play-back of transport streams from a variety of decoders with different architectures or timing schedules.

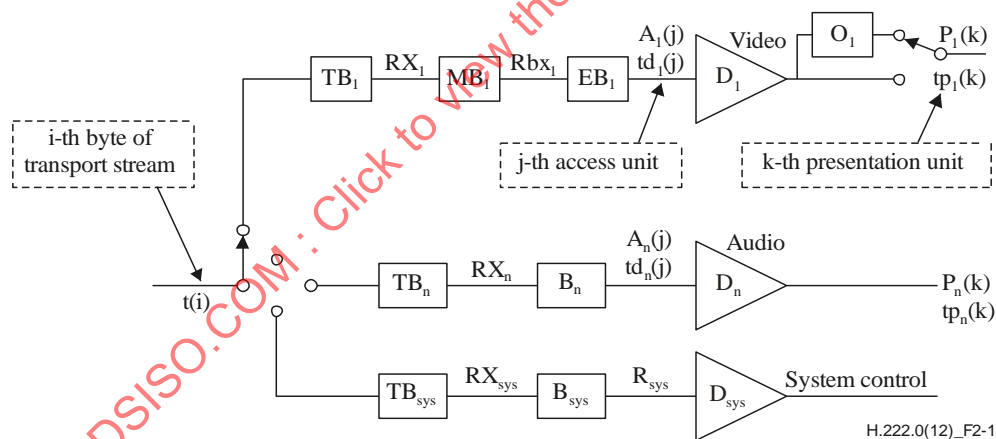

**Figure 2-1 – Transport stream system target decoder notation**

The following notation is used to describe the transport stream system target decoder and is partially illustrated in Figure 2-1.

- i, i', i'' are indices to bytes in the transport stream. The first byte has index 0.
- j is an index to access units in the elementary streams.
- k, k', k'' are indices to presentation units in the elementary streams.
- n is an index to the elementary streams.
- p is an index to transport stream packets in the transport stream.
- t(i) indicates the time in seconds at which the i-th byte of the transport stream enters the system target decoder. The value t(0) is an arbitrary constant.
- PCR(i) is the time encoded in the PCR field measured in units of the period of the 27-MHz system clock where i is the byte index of the final byte of the program\_clock\_reference\_base field.

$A_n(j)$	is the $j$ -th access unit in elementary stream $n$ . $A_n(j)$ is indexed in decoding order.
$td_n(j)$	is the decoding time, measured in seconds, in the system target decoder of the $j$ -th access unit in elementary stream $n$ .
$P_n(k)$	is the $k$ -th presentation unit in elementary stream $n$ . $P_n(k)$ results from decoding $A_n(j)$ . $P_n(k)$ is indexed in presentation order.
$tp_n(k)$	is the presentation time, measured in seconds, in the system target decoder of the $k$ -th presentation unit in elementary stream $n$ .
$t$	is time measured in seconds.
$F_n(t)$	is the fullness, measured in bytes, of the system target decoder input buffer for elementary stream $n$ at time $t$ .
$B_n$	is the main buffer for elementary stream $n$ . It is present only for audio elementary streams.
$BS_n$	is the size of buffer, $B_n$ , measured in bytes.
$B_{sys}$	is the main buffer in the system target decoder for system information for the program that is in the process of being decoded.
$BS_{sys}$	is the size of $B_{sys}$ , measured in bytes.
$MB_n$	is the multiplexing buffer, for elementary stream $n$ . It is present only for video elementary streams.
$MBS_n$	is the size of $MB_n$ , measured in bytes.
$EB_n$	is the elementary stream buffer for elementary stream $n$ . It is present only for video elementary streams.
$EBS_n$	is the size of the elementary stream buffer $EB_n$ , measured in bytes.
$TB_{sys}$	is the transport buffer for system information for the program that is in the process of being decoded.
$TBS_{sys}$	is the size of $TB_{sys}$ , measured in bytes.
$TB_n$	is the transport buffer for elementary stream $n$ .
$TBS_n$	is the size of $TB_n$ , measured in bytes.
$D_{sys}$	is the decoder for system information in program stream $n$ .
$D_n$	is the decoder for elementary stream $n$ .
$O_n$	is the re-order buffer for video elementary stream $n$ .
$R_{sys}$	is the rate at which data are removed from $B_{sys}$ .
$R_{x_n}$	is the rate at which data are removed from $TB_n$ .
$R_{bx_n}$	is the rate at which PES packet payload data are removed from $MB_n$ when the leak method is used. Defined only for video elementary streams.
$R_{bx_n(j)}$	is the rate at which PES packet payload data are removed from $MB_n$ when the $vbv\_delay$ method is used. Defined only for video elementary streams.
$R_{x_{sys}}$	is the rate at which data are removed from $TB_{sys}$ .
$R_{es}$	is the video elementary stream rate coded in a sequence header.

#### 2.4.2.2 System clock frequency

Timing information referenced in the T-STD is carried by several data fields defined in this Specification. Refer to 2.4.3.4 and 2.4.3.6. In PCR fields this information is coded as the sampled value of a program's system clock. The PCR fields are carried in the adaptation field of the transport stream packets with a PID value equal to the PCR\_PID defined in the TS\_program\_map\_section of the program being decoded.

Practical decoders may reconstruct this clock from these values and their respective arrival times. The following are minimum constraints which apply to the program's system clock frequency as represented by the values of the PCR fields when they are received by a decoder.

The value of the system clock frequency is measured in Hz and shall meet the following constraints:

$$27\,000\,000 - 810 \leq \text{system\_clock\_frequency} \leq 27\,000\,000 + 810$$

$$\text{rate of change of system\_clock\_frequency with time} \leq 75 \times 10^{-3} \text{ Hz/s}$$

NOTE – Sources of coded data should follow a tighter tolerance in order to facilitate compliant operation of consumer recorders and playback equipment.

A program's `system_clock_frequency` may be more accurate than required. Such improved accuracy may be transmitted to the decoder via the system clock descriptor described in 2.6.20.

Bit rates defined in this Specification are measured in terms of `system_clock_frequency`. For example, a bit rate of 27 000 000 bits per second in the T-STD would indicate that one byte of data is transferred every eight (8) cycles of the system clock.

The notation "`system_clock_frequency`" is used in several places in this Specification to refer to the frequency of a clock meeting these requirements. For notational convenience, equations in which PCR, PTS, or DTS appear, lead to values of time which are accurate to some integral multiple of  $(300 \times 2^{33}/\text{system\_clock\_frequency})$  seconds. This is due to the encoding of PCR timing information as 33 bits of  $1/300$  of the system clock frequency plus 9 bits for the remainder, and encoding as 33 bits of the system clock frequency divided by 300 for PTS and DTS.

### 2.4.2.3 Input to the transport stream system target decoder

Input to the transport stream system target decoder (T-STD) is a transport stream. A transport stream may contain multiple programs with independent time bases. However, the T-STD decodes only one program at a time. In the T-STD model all timing indications refer to the time base of that program.

Data from the transport stream enters the T-STD at a piecewise constant rate. The time  $t(i)$  at which the  $i$ -th byte enters the T-STD is defined by decoding the program clock reference (PCR) fields in the input stream, encoded in the transport stream packet adaptation field of the program to be decoded and by counting the bytes in the complete transport stream between successive PCRs of that program. The PCR field (see equation 2-1) is encoded in two parts: one, in units of the period of  $1/300$  times the system clock frequency, called `program_clock_reference_base` (see equation 2-2), and one in units of the system clock frequency called `program_clock_reference_extension` (see equation 2-3). The values encoded in these are computed by  $\text{PCR\_base}(i)$  (see equation 2-2) and  $\text{PCR\_ext}(i)$  (see equation 2-3) respectively. The value encoded in the PCR field indicates the time  $t(i)$ , where  $i$  is the index of the byte containing the last bit of the `program_clock_reference_base` field.

Specifically:

$$\text{PCR}(i) = \text{PCR\_base}(i) \times 300 + \text{PCR\_ext}(i) \quad (2-1)$$

where:

$$\text{PCR\_base}(i) = ((\text{system\_clock\_frequency} \times t(i)) \text{DIV } 300) \% 2^{33} \quad (2-2)$$

$$\text{PCR\_ext}(i) = ((\text{system\_clock\_frequency} \times t(i)) \text{DIV } 1) \% 300 \quad (2-3)$$

For all other bytes the input arrival time,  $t(i)$  shown in equation 2-4 below, is computed from  $\text{PCR}(i'')$  and the transport rate at which data arrive, where the transport rate is determined as the number of bytes in the transport stream between the bytes containing the last bit of two successive `program_clock_reference_base` fields of the same program divided by the difference between the time values encoded in these same two PCR fields.

$$t(i) = \frac{\text{PCR}(i'')}{\text{system\_clock\_frequency}} + \frac{i - i''}{\text{transport\_rate}(i)} \quad (2-4)$$

where:

$i$  is the index of any byte in the transport stream for  $i'' < i < i'$ .

$i''$  is the index of the byte containing the last bit of the most recent `program_clock_reference_base` field applicable to the program being decoded.

$\text{PCR}(i'')$  is the time encoded in the program clock reference base and extension fields in units of the system clock.

The transport rate for any byte  $i$  between byte  $i''$  and byte  $i'$  is given by:

$$\text{transport\_rate}(i) = \frac{((i' - i'') \times \text{system\_clock\_frequency})}{\text{PCR}(i') - \text{PCR}(i'')} \quad (2-5)$$

where:

$i'$  is the index of the byte containing the last bit of the immediately following program\_clock\_reference\_base field applicable to the program being decoded.

In the case of a time-base discontinuity, indicated by the discontinuity\_indicator in the transport packet adaptation field, the definition given in equation 2-4 and equation 2-5 for the time of arrival of bytes at the input to the T-STD is not applicable between the last PCR of the old time base and the first PCR of the new time base. In this case the time of arrival of these bytes is determined according to equation 2-4 with the modification that the transport rate used is that applicable between the last and next to last PCR of the old time base.

A tolerance is specified for the PCR values. The PCR tolerance is defined as the maximum inaccuracy allowed in received PCRs. This inaccuracy may be due to imprecision in the PCR values or to PCR modification during re-multiplexing. It does not include errors in packet arrival time due to network jitter or other causes. The PCR tolerance is  $\pm 500$  ns.

In the T-STD model, the inaccuracy will be reflected as an inaccuracy in the calculated transport rate using equation 2-5.

### Transport streams with multiple programs and variable rate

Transport streams may contain multiple programs which have independent time bases. Separate sets of PCRs, as indicated by the respective PCR\_PID values, are required for each such independent program, and therefore the PCRs cannot be co-located. The transport stream rate is piecewise constant for the program entering the T-STD. Therefore, if the transport stream rate is variable it can only vary at the PCRs of the program under consideration. Since the PCRs, and therefore the points in the transport Stream where the rate varies, are not co-located, the rate at which the transport stream enters the T-STD would have to differ depending on which program is entering the T-STD. Therefore, it is not possible to construct a consistent T-STD delivery schedule for an entire transport stream when that transport stream contains multiple programs with independent time bases and the rate of the transport stream is variable. It is straightforward, however, to construct constant bit rate transport streams with multiple variable rate programs.

#### 2.4.2.4 Buffering

Complete transport stream packets containing system information, for the program selected for decoding, enter the system transport buffer,  $TB_{sys}$ , at the transport stream rate. These include transport stream packets whose PID values are 0, 1, 2 or 3, and all transport stream packets identified via the program association table (see Table 2-30) as having the program\_map\_PID value for the selected program. Network information table (NIT) data as specified by the NIT PID is not transferred to  $TB_{sys}$ .

NOTE 1 – Size of IPMP control information table could be large, and the repetition rate of this table should be adjusted to meet the buffer requirement.

All bytes that enter the buffer  $TB_n$  are removed at the rate  $R_{x_n}$  specified below. Bytes which are part of the PES packet header or its contents are delivered to the main buffer  $B_n$  for audio elementary streams and system data, and to the multiplexing buffer  $MB_n$  for video elementary streams. Other bytes are not, and may be used to control the system. Duplicate transport stream packets are not delivered to  $B_n$ ,  $MB_n$ , or  $B_{sys}$ .

The buffer  $TB_n$  is emptied as follows:

- When there is no data in  $TB_n$ ,  $R_{x_n}$  is equal to zero.
- Otherwise for video:

$$R_{x_n} = 1.2 \times R_{\max}[\text{profile, level}]$$

where:

$R_{\max}[\text{profile, level}]$  is specified according to the profile and level which can be found in Table 8-13 of Rec. ITU-T H.262 | ISO/IEC 13818-2. This table specifies the upper bound of the rate of each elementary video stream within a specific profile and level.

$R_{x_n}$  is equal to  $1.2 \times R_{\max}$  for ISO/IEC 11172-2 constrained parameter video streams, where  $R_{\max}$  refers to the maximum bitrate for a constrained parameters bitstream in ISO/IEC 11172-2.

For ISO/IEC 13818-7 ADTS audio:

Number of Channels	$R_{x_n}$ [bit/s]
1 .. 2	2 000 000
3 .. 8	5 529 600
9 .. 12	8 294 400
13 .. 48	33 177 600

Channels: The number of full-bandwidth audio output channels plus the number of independently switched coupling channel elements within the same elementary audio stream. For example, in the typical case that there are no independently switched coupling channel elements, mono is 1 channel, stereo is 2 channels and 5.1 channel surround is five channels (the low-frequency effects (LFE) channel is not counted).

For other audio,

$$R_{x_n} = 2 \times 10^6 \text{ bits per second}$$

For systems data:

$$R_{x_n} = 1 \times 10^6 \text{ bits per second}$$

$R_{x_n}$  is measured with respect to the system clock frequency.

Complete transport stream packets containing system information, for the program selected for decoding, enter the system transport buffer,  $TB_{sys}$ , at the transport stream rate. These include transport stream packets whose PID values are 0, 1, 2 and 3 (if present), and all transport stream packets identified via the program association table (PAT) (see Table 2-30) as having the program\_map\_PID value for the selected program. Network information table (NIT) data as specified by the NIT PID is not transferred to  $TB_{sys}$ .

Bytes are removed from  $TB_{sys}$  at the rate  $R_{x_{sys}}$  and delivered to  $B_{sys}$ . Each byte is transferred instantaneously.

Duplicate transport stream packets are not delivered to  $B_{sys}$ .

Transport packets which do not enter any  $TB_n$  or  $TB_{sys}$  are discarded.

The transport buffer size is fixed at 512 bytes.

The elementary stream buffer sizes  $EBS_1$  through  $EBS_n$  are defined for video as equal to the `vbv_buffer_size` as it is carried in the sequence header. Refer to the summary of constrained parameters in ISO/IEC 11172-2 and Table 8-14 of Rec. ITU-T H.262 | ISO/IEC 13818-2.

NOTE 2 – In the following equations, unit conversion should be implicitly performed as appropriate. Values expressed in bits are implicitly converted into values expressed in bytes by:  $number\_of\_bytes = (number\_of\_bits + 7) / 8$ .

The multiplexing buffer size  $MBS_1$  through  $MBS_n$  are defined for video as follows:

For Low and Main level:

$$MBS_n = BS_{mux} + BS_{oh} + VBV_{max}[profile, level] - vbv\_buffer\_size$$

where  $BS_{oh}$ , PES packet overhead buffering is defined as:

$$BS_{oh} = (1/750) \text{ seconds} \times R_{max}[profile, level]$$

and  $BS_{mux}$ , additional multiplex buffering is defined as:

$$BS_{mux} = 0.004 \text{ seconds} \times R_{max}[profile, level]$$

and where  $VBV_{max}[profile, level]$  is defined in Table 8-14 of Rec. ITU-T H.262 | ISO/IEC 13818-2 and  $R_{max}[profile, level]$  is defined in Table 8-13 of Rec. ITU-T H.262 | ISO/IEC 13818-2, and `vbv_buffer_size` is carried in the sequence header described in 6.2.2 of Rec. ITU-T H.262 | ISO/IEC 13818-2.

For High 1440 and High level:

$$MBS_n = BS_{mux} + BS_{oh}$$

where  $BS_{oh}$  is defined as:

$$BS_{oh} = (1/750) \text{ seconds} \times R_{max}[profile, level]$$

and  $BS_{mux}$  is defined as:

$$BS_{mux} = 0.004 \text{ seconds} \times R_{max}[profile, level]$$

and where  $R_{\max}[\text{profile, level}]$  is defined in Table 8-13 of Rec. ITU-T H.262 | ISO/IEC 13818-2.

For Constrained Parameters ISO/IEC 11172-2 bitstreams:

$$MBS_n = BS_{mux} + BS_{oh} + vbv\_max - vbv\_buffer\_size$$

where  $BS_{oh}$  is defined as:

$$BS_{oh} = (1/750) \text{ seconds} \times R_{\max}$$

and  $BS_{mux}$  is defined as:

$$BS_{mux} = 0.004 \text{ seconds} \times R_{\max}$$

and where  $R_{\max}$  and  $vbv\_max$  refer to the maximum bitrate and the maximum  $vbv\_buffer\_size$  for a Constrained Parameters bitstream in ISO/IEC 11172-2 respectively.

A portion  $BS_{mux} = 4 \text{ ms} \times R_{\max}[\text{profile, level}]$  of the  $MBS_n$  is allocated for buffering to allow multiplexing. The remainder is available for  $BS_{oh}$  and may also be available for initial multiplexing.

NOTE 3 – Buffer occupancy by PES packet overhead is directly bounded in PES streams by the PES-STD which is defined in 2.5.2.4. It is possible, but not necessary, to utilize PES streams to construct transport streams.

### Buffer $BS_n$

The main buffer sizes  $BS_1$  through  $BS_n$  are defined as follows.

### Audio

For ISO/IEC 13818-7 ADTS audio:

Number of Channels	$BS_n$ [bytes]
1 .. 2	3 584
3 .. 8	8 976
9 .. 12	12 804
13 .. 48	51 216

Channels: The number of full-bandwidth audio output channels plus the number of independently switched coupling channel elements within the same elementary audio stream. For example, in the typical case that there are no independently switched coupling channel elements, mono is 1 channel, stereo is 2 channels, and 5.1 channel surround is 5 channels (the LFE channel is not counted).

For other audio:

$$BS_n = BS_{mux} + BS_{dec} + BS_{oh} = 3584 \text{ bytes}$$

The size of the access unit decoding buffer  $BS_{dec}$ , and the PES packet overhead buffer  $BS_{oh}$  are constrained by:

$$BS_{dec} + BS_{oh} \leq 2848 \text{ bytes}$$

A portion (736 bytes) of the 3584 byte buffer is allocated for buffering to allow multiplexing. The rest, 2848 bytes, are shared for access unit buffering  $BS_{dec}$ ,  $BS_{oh}$  and additional multiplexing.

### Systems

The main buffer  $B_{sys}$  for system data is of size  $BS_{sys} = 1536$  bytes.

### Video

For video elementary streams, data is transferred from  $MB_n$  to  $EB_n$  using one of two methods: the leak method or the video buffering verifier (VBV) delay method.

**Leak method**

The leak method transfers data from  $MB_n$  to  $EB_n$  using a leak rate  $R_{bx}$ . The leak method is used whenever any of the following is true:

- the STD descriptor (refer to 2.6.32) for the elementary stream is not present in the transport stream;
- the STD descriptor is present and the leak\_valid flag has a value of '1';
- the STD descriptor is present, the leak\_valid has a value of '0', and the vbv\_delay fields coded in the video stream have the value 0xFFFF; or
- trick mode status is true (refer to 2.4.3.7).

For Low and Main level:

$$Rbx_n = R_{max} [profile, level]$$

For High-1440 and High level:

$$Rbx_n = Min\{1.05 \times R_{es}, R_{max}[profile, level]\}$$

For Constrained Parameters bitstream in ISO/IEC 11172-2:

$$Rbx_n = 1.2 \times R_{max}$$

where  $R_{max}$  is the maximum bit rate for a Constrained Parameters bitstream in ISO/IEC 11172-2.

If there is PES packet payload data in  $MB_n$ , and buffer  $EB_n$  is not full, the PES packet payload is transferred from  $MB_n$  to  $EB_n$  at a rate equal to  $Rbx_n$ . If  $EB_n$  is full, data are not removed from  $MB_n$ . When a byte of data is transferred from  $MB_n$  to  $EB_n$ , all PES packet header bytes that are in  $MB_n$  and immediately precede that byte, are instantaneously removed and discarded. When there is no PES packet payload data present in  $MB_n$ , no data is removed from  $MB_n$ . All data that enters  $MB_n$  leaves it. All PES packet payload data bytes enter  $EB_n$  instantaneously upon leaving  $MB_n$ .

**Vbv\_delay method**

The vbv\_delay method specifies precisely the time at which each byte of coded video data is transferred from  $MB_n$  to  $EB_n$ , using the vbv\_delay values coded in the video elementary stream. The vbv\_delay method is used whenever the STD descriptor (refer to 2.6.32) for this elementary stream is present in the transport stream, the leak\_valid flag in the descriptor has the value '0', and vbv\_delay fields coded in the video stream are not equal to 0xFFFF. If any vbv\_delay values in a video sequence are not equal to 0xFFFF, none of the vbv\_delay fields in that sequence shall be equal to 0xFFFF (refer to ISO/IEC 11172-2 and Rec. ITU-T H.262 | ISO/IEC 13818-2).

When the vbv\_delay method is used, the final byte of the video picture start code for picture  $j$  is transferred from  $MB_n$  to the  $EB_n$  at the time  $td_n(j) - vbv\_delay(j)$ , where  $td_n(j)$  is the decoding time of picture  $j$ , as defined above, and  $vbv\_delay(j)$  is the delay time, in seconds, indicated by the vbv\_delay field of picture  $j$ . The transfer of bytes between the final bytes of successive picture start codes (including the final byte of the second start code), into the buffer  $EB_n$ , is at a piecewise constant rate,  $R_{bx}(j)$ , which is specified for each picture  $j$ . Specifically, the rate,  $R_{bx}(j)$ , of transfer into this buffer is given by:

$$R_{bx}(j) = NB(j) / (vbv\_delay(j) - vbv\_delay(j+1) + td_n(j+1) - td_n(j)) \tag{2-6}$$

where  $NB(j)$  is the number of bytes between the final bytes of the picture start codes (including the final byte of the second start code) of pictures  $j$  and  $j + 1$ , excluding PES packet header bytes.

NOTE 4 –  $vbv\_delay(j + 1)$  and  $td_n(j + 1)$  may have values that differ from those normally expected for periodic video display if the low\_delay flag in the video sequence extension is set to '1'. It may not be possible to determine the correct values by examination of the bit stream.

The  $R_{bx}(j)$  derived from equation 2-6 shall be less than or equal to  $R_{max}[profile, level]$  for elementary streams of stream type 0x02 (refer to Table 2-34), where  $R_{max}[profile, level]$  is defined in Rec. ITU-T H.262 | ISO/IEC 13818-2, and shall be less than or equal to the maximum bit rate allowed for constrained parameter video elementary streams of stream type 0x01, refer to ISO/IEC 11172-2.

When a byte of data is transferred from  $MB_n$  to  $EB_n$ , all PES packet header bytes that are in  $MB_n$  and immediately precede that byte are instantaneously removed and discarded. All data that enters  $MB_n$  leaves it. All PES packet payload data bytes enter  $EB_n$  instantaneously upon leaving  $MB_n$ .

## Removal of access units

For each elementary stream buffer  $EB_n$  and main buffer  $B_n$  all data for the access unit that has been in the buffer longest,  $A_n(j)$ , and any stuffing bytes that immediately precede it that are present in the buffer at the time  $td_n(j)$  are removed instantaneously at time  $td_n(j)$ . The decoding time  $td_n(j)$  is specified in the DTS or PTS fields (refer to 2.4.3.6). Decoding times  $td_n(j+1)$ ,  $td_n(j+2)$ , ... of access units without encoded DTS or PTS fields which directly follow access unit  $j$  may be derived from information in the elementary stream. Refer to Annex C of Rec. ITU-T H.262 | ISO/IEC 13818-2, ISO/IEC 13818-3, or ISO/IEC 11172. Also refer to 2.7.5. In the case of audio, all PES packet headers that are stored immediately before the access unit or that are embedded within the data of the access unit are removed simultaneously with the removal of the access unit. As the access unit is removed it is instantaneously decoded to a presentation unit.

## System data

In the case of system data, data is removed from the main buffer  $B_{sys}$  at a rate of  $R_{sys}$  whenever there is at least 1 byte available in buffer  $B_{sys}$ .

$$R_{sys} = \max(80\,000 \text{ bits/s}, \textit{transport\_rate}(i) \times 8 \text{ bits/byte} / 500) \quad (2-7)$$

NOTE 5 – The intention of increasing  $R_{sys}$  in the case of high transport rates is to allow an increased data rate for the Program-specific information.

## Low delay

When the `low_delay` flag in the video sequence extension is set to '1' (see 6.2.2.3 of Rec. ITU-T H.262 | ISO/IEC 13818-2) the  $EB_n$  buffer may underflow. In this case, when the T-STD elementary stream buffer  $EB_n$  is examined at the time specified by  $td_n(j)$ , the complete data for the access unit may not be present in the buffer  $EB_n$ . When this case arises, the buffer shall be re-examined at intervals of two field-periods until the data for the complete access unit is present in the buffer. At this time the entire access unit shall be removed from buffer  $EB_n$  instantaneously. Overflow of buffer  $EB_n$  shall not occur.

When the `low_delay_mode` flag is set to '1',  $EB_n$  underflow is allowed to occur continuously without limit. The T-STD decoder shall remove access unit data from buffer  $EB_n$  at the earliest time consistent with the paragraph above and any DTS or PTS values encoded in the bit stream. Note that the decoder may be unable to re-establish correct decoding and display times as indicated by DTS and PTS until the  $EB_n$  buffer underflow situation ceases and a PTS or DTS is found in the bit stream.

## Trick mode

When the `DSM_trick_mode` flag (2.4.3.6) is set to '1' in the PES Packet header of a packet containing the start of a B-type video access unit and the `trick_mode_control` field is set to '001' (slow motion) or '010' (freeze frame), or '100' (slow reverse) the B-picture access unit is not removed from the video data buffer  $EB_n$  until the last time of possibly multiple times that any field of the picture is decoded and presented. Repetition of the presentation of fields and pictures is defined in 2.4.3.8 under slow motion, slow reverse, and `field_id_cntrl`. The access unit is removed instantaneously from  $EB_n$  at the indicated time, which is dependent on the value of `rep_cntrl`.

When the `DSM_trick_mode` flag is set to '1' in the PES packet header of a packet containing the first byte of a picture start code, `trick_mode_status` becomes true when that picture start code in the PES packet is removed from buffer  $EB_n$ . Trick mode status remains true until a PES packet header is received by the T-STD in which the `DSM_trick_mode` flag is set to '0' and the first byte of the picture start code after that PES packet header is removed from buffer  $EB_n$ . When trick mode status is true, the buffer  $EB_n$  may underflow. All other constraints from normal streams are retained when trick mode status is true.

### 2.4.2.5 Decoding

Elementary streams buffered in  $B_1$  through  $B_n$  and  $EB_1$  through  $EB_n$  are decoded instantaneously by decoders  $D_1$  through  $D_n$  and may be delayed in re-order buffers  $O_1$  through  $O_n$  before being presented at the output of the T-STD. Re-order buffers are used only in the case of a video elementary stream when some access units are not carried in presentation order. These access units will need to be re-ordered before presentation. In particular, if  $P_n(k)$  is an I-picture or a P-picture carried before one or more B-pictures, then it must be delayed in the re-order buffer,  $O_n$ , of the T-STD before being presented. Any picture previously stored in  $O_n$  is presented before the current picture can be stored.  $P_n(k)$  should be delayed until the next I-picture or P-picture is decoded. While it is stored in the re-order buffer, the subsequent B-pictures are decoded and presented.

The time at which a presentation unit  $P_n(k)$  is presented is  $tp_n(k)$ . For presentation units that do not require re-ordering delay,  $tp_n(k)$  is equal to  $td_n(j)$  since the access units are decoded instantaneously; this is the case, for example, for B-frames. For presentation units that are delayed,  $tp_n(k)$  and  $td_n(j)$  differ by the time that  $P_n(k)$  is delayed in the re-order buffer, which is a multiple of the nominal picture period. Care should be taken to use adequate re-ordering delay from the

beginning of video elementary streams to meet the requirements of the entire stream. For example, a stream which initially has only I- and P-pictures but later includes B-pictures should include re-ordering delay starting at the beginning of the stream.

Rec. ITU-T H.262 | ISO/IEC 13818-2 explains re-ordering of video pictures in greater detail.

#### 2.4.2.6 Presentation

The function of a decoding system is to reconstruct presentation units from compressed data and to present them in a synchronized sequence at the correct presentation times. Although real audio and visual presentation devices generally have finite and different delays and may have additional delays imposed by post-processing or output functions, the system target decoder models these delays as zero.

In the T-STD in Figure 2-1 the display of a video presentation unit (a picture) occurs instantaneously at its presentation time,  $tp_n(k)$ .

In the T-STD the output of an audio presentation unit starts at its presentation time,  $tp_n(k)$ , when the decoder instantaneously presents the first sample. Subsequent samples in the presentation unit are presented in sequence at the audio sampling rate.

#### 2.4.2.7 Buffer management

Transport streams shall be constructed so that conditions defined in this subclause are satisfied. This subclause makes use of the notation defined for the system target decoder.

$TB_n$  and  $TB_{sys}$  shall not overflow.  $TB_n$  and  $TB_{sys}$  shall empty at least once every second.  $B_n$  shall not overflow nor underflow.  $B_{sys}$  shall not overflow.

$EB_n$  shall not underflow except when the low delay flag in the video sequence extension is set to '1' (refer to 6.2.2.3 in Rec. ITU-T H.262 | ISO/IEC 13818-2) or `trick_mode` status is true.

When the leak method for specifying transfers is in effect,  $MB_n$  shall not overflow, and shall empty at least once every second.  $EB_n$  shall not overflow.

When the `vbv_delay` method for specifying transfers is in effect,  $MB_n$  shall not overflow nor underflow, and  $EB_n$  shall not overflow.

The delay of any data through the system target decoder buffers shall be less than or equal to one second except for still picture video data, ISO/IEC 14496, ISO/IEC 23008-2, ISO/IEC 23090-3, ISO/IEC 23094-1 and ISO/IEC 23094-2 streams. Specifically:  $td_n(j) - t(i) \leq 1$  second for all  $j$ , and all bytes  $i$  in access unit  $A_n(j)$ .

For still picture video data, the delay is constrained by  $td_n(j) - t(i) \leq 60$  seconds for all  $j$ , and all bytes  $i$  in access unit  $A_n(j)$ .

For ISO/IEC 14496, ISO/IEC 23008-2, ISO/IEC 23090-3, ISO/IEC 23094-1 and ISO/IEC 23094-2 streams, the delay is constrained by  $td_n(j) - t(i) \leq 10$  seconds for all  $j$ , and all bytes  $i$  in access unit  $A_n(j)$ .

#### Definition of overflow and underflow

Let  $F_n(t)$  be the instantaneous fullness of T-STD buffer  $B_n$ .

$F_n(t) = 0$  instantaneously before  $t = t(0)$

Overflow does not occur if:

$$F_n(t) \leq BS_n$$

for all  $t$  and  $n$ .

Underflow does not occur if:

$$0 \leq F_n(t)$$

for all  $t$  and  $n$ .

#### 2.4.2.8 T-STD extensions for carriage of ISO/IEC 14496 data

For decoding of ISO/IEC 14496 data carried in a transport stream the T-STD model is extended. T-STD parameters for decoding of individual ISO/IEC 14496 elementary streams are defined in 2.11.2, while 2.11.3 defines T-STD extensions and parameters for decoding of ISO/IEC 14496 scenes and associated streams.

#### 2.4.2.9 T-STD extensions for carriage of Rec. ITU-T H.264 | ISO/IEC 14496-10 video

To define the decoding in the T-STD of Rec. ITU-T H.264 | ISO/IEC 14496-10 video streams carried in a transport stream, the T-STD model needs to be extended. The T-STD extension and T-STD parameters for decoding of AVC video streams conforming to one or more profiles defined in Annex A of Rec. ITU-T H.264 | ISO/IEC 14496-10 video streams are defined in 2.14.3.1, T-STD extension and T-STD parameters for decoding of AVC video streams conforming to one or more profiles defined in Annex G of Rec. ITU-T H.264 | ISO/IEC 14496-10 are defined in 2.14.3.5, and T-STD extension and T-STD parameters for decoding of AVC video streams conforming to one or more profiles defined in Annex H of Rec. ITU-T H.264 | ISO/IEC 14496-10 are defined in 2.14.3.7.

#### 2.4.2.10 T-STD extensions for carriage of ISO/IEC 14496-17 text streams

To define the decoding in the T-STD of ISO/IEC 14496-17 text streams carried in a transport stream, the T-STD model needs to be extended. The T-STD extension and T-STD parameters for decoding of ISO/IEC 14496-17 text streams are defined in 2.15.3.1.

#### 2.4.2.11 T-STD extensions for carriage of J2K video elementary streams

The interpretation, extensions, use and constraints for syntax elements in the adaptation header (2.4.3.4 and 2.4.3.5) for JPEG 2000 part 1 video are defined in S.5.

The interpretation, extensions, use and constraints for syntax elements in the PES header (2.4.3.6 and 2.4.3.7) for JPEG 2000 Part 1 video are defined in S.5.

To define the decoding of J2K video elementary streams carried in a transport stream, the T-STD model needs to be extended. The T-STD extensions and T-STD parameters for decoding of J2K video elementary streams conforming to one or more profiles defined in Rec. ITU-T T.800 (2002) | ISO/IEC 15444-1:2004 are defined in S.6.

NOTE – No extensions are specified for P-STD model, as carriage of J2K video elementary streams in program streams is not supported.

#### 2.4.2.12 T-STD extensions for carriage of HEVC

T-STD extensions and T-STD parameters for the decoding of HEVC video streams are defined in 2.17.2 and 2.17.3. Program stream support including P-STD extensions and P-STD parameters are not specified for HEVC video streams.

#### 2.4.2.13 T-STD extensions for carriage of MVCD video sub-bitstream

T-STD extensions and T-STD parameters for decoding of MVCD video sub-bitstreams are defined in 2.14.1 and 2.14.3.7.

NOTE – Program stream extensions are not specified for MVCD video sub-bitstreams.

#### 2.4.2.14 T-STD extensions for carriage of MV HEVC and SHVC

T-STD extensions and T-STD parameters for decoding of HEVC layered video streams are defined in 2.17.4. Program stream support including P-STD extensions and P-STD parameters are not specified for HEVC extension video streams.

#### 2.4.2.15 T-STD extensions for carriage of JPEG XS video elementary streams

The interpretation, extensions, use and constraints for syntax elements in the adaptation header (2.4.3.4 and 2.4.3.5) for JPEG XS Part-1 video are defined in W.5.

The interpretation, extensions, use and constraints for syntax elements in the PES header (2.4.3.6 and 2.4.3.7) for JPEG XS Part-1 video are defined in W.5.

To define the decoding of JPEG XS video elementary streams carried in a Transport Stream, the T-STD model needs to be extended. The T-STD extensions and T-STD parameters for decoding of JPEG XS video elementary streams conforming to one or more profiles defined in ISO/IEC 21122-2 are defined in W.6.

NOTE – No extensions are specified for P-STD model, as carriage of JPEG XS video elementary streams in program streams is not supported.

#### 2.4.2.16 T-STD extensions for carriage of VVC

T-STD extensions and T-STD parameters for decoding of VVC video streams are defined in 2.23.2 and 2.23.3. Program stream support including P-STD extensions and P-STD parameters are not specified for VVC video streams.

#### 2.4.2.17 T-STD extensions for carriage of EVC

T-STD extensions and T-STD parameters for decoding of EVC video streams are defined in 2.24.2. Program stream support including P-STD extensions and P-STD parameters are not specified for EVC video streams.

2.4.3 Specification of the transport stream syntax and semantics

The following syntax describes a stream of bytes. Transport stream packets shall be 188 bytes long.

2.4.3.1 Transport stream

See Table 2-1.

Table 2-1 – Transport stream

Syntax	No. of bits	Mnemonic
<pre>MPEG_transport_stream() {     do {         transport_packet()     } while (nextbits() == sync_byte) }</pre>		

2.4.3.2 Transport stream packet layer

See Table 2-2.

Table 2-2 – Transport packet of this Recommendation | International Standard

Syntax	No. of bits	Mnemonic
<pre>transport_packet(){     sync_byte     transport_error_indicator     payload_unit_start_indicator     transport_priority     PID     transport_scrambling_control     adaptation_field_control     continuity_counter     if(adaptation_field_control == '10'    adaptation_field_control == '11'){         adaptation_field()     }     if(adaptation_field_control == '01'    adaptation_field_control == '11') {         for (i = 0; i &lt; N; i++){             data_byte         }     } }</pre>	<p>8</p> <p>1</p> <p>1</p> <p>1</p> <p>13</p> <p>2</p> <p>2</p> <p>4</p> <p>8</p>	<p>bslbf</p> <p>bslbf</p> <p>bslbf</p> <p>bslbf</p> <p>uimsbf</p> <p>bslbf</p> <p>bslbf</p> <p>uimsbf</p> <p>bslbf</p>

2.4.3.3 Semantic definition of fields in transport stream packet layer

**sync\_byte** – The sync\_byte is a fixed 8-bit field whose value is '0100 0111' (0x47). Sync\_byte emulation in the choice of values for other regularly occurring fields, such as PID, should be avoided.

**transport\_error\_indicator** – The transport\_error\_indicator is a 1-bit flag. When set to '1' it indicates that at least 1 uncorrectable bit error exists in the associated transport stream packet. This bit may be set to '1' by entities external to the transport layer. When set to '1' this bit shall not be reset to '0' unless the bit value(s) in error have been corrected.

**payload\_unit\_start\_indicator** – The payload\_unit\_start\_indicator is a 1-bit flag which has normative meaning for transport stream packets that carry PES packets (refer to 2.4.3.6) or transport stream section data (refer to Table 2-31 in 2.4.4.5).

When the payload of the transport stream packet contains PES packet data, the payload\_unit\_start\_indicator has the following significance: a '1' indicates that the payload of this transport stream packet will commence with the first byte of a PES packet and a '0' indicates no PES packet shall start in this transport stream packet. If the

payload\_unit\_start\_indicator is set to '1', then one and only one PES packet starts in this transport stream packet. This also applies to private streams of stream\_type 6 (refer to Table 2-34).

When the payload of the transport stream packet contains transport stream section data, the payload\_unit\_start\_indicator has the following significance: if the transport stream packet carries the first byte of a section, the payload\_unit\_start\_indicator value shall be '1', indicating that the first byte of the payload of this transport stream packet carries the pointer\_field. If the transport stream packet does not carry the first byte of a section, the payload\_unit\_start\_indicator value shall be '0', indicating that there is no pointer\_field in the payload. Refer to 2.4.4.2 and 2.4.4.3. This also applies to private streams of stream\_type 5 (refer to Table 2-34).

For null packets the payload\_unit\_start\_indicator shall be set to '0'.

The meaning of this bit for transport stream packets carrying only private data is not defined in this Specification.

**transport\_priority** – The transport\_priority is a 1-bit indicator. When set to '1' it indicates that the associated packet is of greater priority than other packets having the same PID which do not have the bit set to '1'. The transport mechanism can use this to prioritize its data within an elementary stream. Depending on the application the transport\_priority field may be coded regardless of the PID or within one PID only. This field may be changed by channel-specific encoders or decoders.

**PID** – The PID is a 13-bit field, indicating the type of the data stored in the packet payload. PID value 0x0000 is reserved for the program association table (see Table 2-30). PID value 0x0001 is reserved for the conditional access table (see Table 2-32). PID value 0x0002 is reserved for the transport stream description table (see Table 2-36), PID value 0x0003 is reserved for IPMP control information table (see ISO/IEC 13818-11) and PID values 0x0004-0x000F are reserved. PID value 0x1FFF is reserved for null packets (see Table 2-3).

**Table 2-3 – PID table**

Value	Description
0x0000	Program association table
0x0001	Conditional access table
0x0002	Transport stream description table
0x0003	IPMP control information table
0x0004	Adaptive streaming information (see Note 2)
0x0005 .. 0x000F	Reserved
0x0010 .. 0x1FFE	May be assigned as network_PID, Program_map_PID, elementary_PID, or for other purposes
0x1FFF	Null packet
NOTE 1 – The transport packets with PID values 0x0000, 0x0001, and 0x0010-0x1FFE are allowed to carry a PCR.	
NOTE 2 – Payload syntax is defined in 5.10.3.3.5 of ISO/IEC 23009-1.	

**transport\_scrambling\_control** – This 2-bit field indicates the scrambling mode of the transport stream packet payload. The transport stream packet header, and the adaptation field when present, shall not be scrambled. In the case of a null packet the value of the transport\_scrambling\_control field shall be set to '00' (see Table 2-4).

**Table 2-4 – Scrambling control values**

Value	Description
'00'	Not scrambled
'01'	User-defined
'10'	User-defined
'11'	User-defined

**adaptation\_field\_control** – This 2-bit field indicates whether this transport stream packet header is followed by an adaptation field and/or payload (see Table 2-5).

**Table 2-5 – Adaptation field control values**

Value	Description
'00'	Reserved for future use by ISO/IEC
'01'	No adaptation_field, payload only
'10'	Adaptation_field only, no payload
'11'	Adaptation_field followed by payload

Rec. ITU-T H.222.0 | ISO/IEC 13818-1 decoders shall discard transport stream packets with the adaptation\_field\_control field set to a value of '00'. In the case of a null packet the value of the adaptation\_field\_control shall be set to '01'.

**continuity\_counter** – The continuity\_counter is a 4-bit field incrementing with each transport stream packet with the same PID. The continuity\_counter wraps around to 0 after its maximum value. The continuity\_counter shall not be incremented when the adaptation\_field\_control of the packet equals '00' or '10'.

In transport streams, duplicate packets may be sent as two, and only two, consecutive transport stream packets of the same PID. The duplicate packets shall have the same continuity\_counter value as the original packet and the adaptation\_field\_control field shall be equal to '01' or '11'. In duplicate packets each byte of the original packet shall be duplicated, with the exception that in the program clock reference fields, if present, a valid value shall be encoded.

The continuity\_counter in a particular transport stream packet is continuous when it differs by a positive value of one from the continuity\_counter value in the previous transport stream packet of the same PID, or when either of the non-incrementing conditions (adaptation\_field\_control set to '00' or '10', or duplicate packets as described above) are met. The continuity counter may be discontinuous when the discontinuity\_indicator is set to '1' (refer to 2.4.3.4). In the case of a null packet the value of the continuity\_counter is undefined.

**data\_byte** – Data bytes shall be contiguous bytes of data from the PES packets (refer to 2.4.3.6), transport stream sections (refer to 2.4.4), packet stuffing bytes after transport stream sections, or private data not in these structures as indicated by the PID. In the case of null packets with PID value 0x1FFF data\_bytes may be assigned any value. The number of data\_bytes, N, is specified by 184 minus the number of bytes in the adaptation\_field(), as described in 2.4.3.4.

**2.4.3.4 Adaptation field**

See Table 2-6.

**Table 2-6 – Transport stream adaptation field**

Syntax	No. of bits	Mnemonic
adaptation_field() {		
<b>adaptation_field_length</b>	<b>8</b>	<b>uimsbf</b>
if (adaptation_field_length > 0) {		
<b>discontinuity_indicator</b>	<b>1</b>	<b>bslbf</b>
<b>random_access_indicator</b>	<b>1</b>	<b>bslbf</b>
<b>elementary_stream_priority_indicator</b>	<b>1</b>	<b>bslbf</b>
<b>PCR_flag</b>	<b>1</b>	<b>bslbf</b>
<b>OPCR_flag</b>	<b>1</b>	<b>bslbf</b>
<b>splicing_point_flag</b>	<b>1</b>	<b>bslbf</b>
<b>transport_private_data_flag</b>	<b>1</b>	<b>bslbf</b>
<b>adaptation_field_extension_flag</b>	<b>1</b>	<b>bslbf</b>
if (PCR_flag == '1') {		
<b>program_clock_reference_base</b>	<b>33</b>	<b>uimsbf</b>
<b>reserved</b>	<b>6</b>	<b>bslbf</b>
<b>program_clock_reference_extension</b>	<b>9</b>	<b>uimsbf</b>
}		
if (OPCR_flag == '1') {		
<b>original_program_clock_reference_base</b>	<b>33</b>	<b>uimsbf</b>
<b>reserved</b>	<b>6</b>	<b>bslbf</b>
<b>original_program_clock_reference_extension</b>	<b>9</b>	<b>uimsbf</b>
}		
if (splicing_point_flag == '1') {		
<b>splice_countdown</b>	<b>8</b>	<b>tcimsbf</b>
}		
if (transport_private_data_flag == '1') {		
<b>transport_private_data_length</b>	<b>8</b>	<b>uimsbf</b>
}		

Table 2-6 – Transport stream adaptation field

Syntax	No. of bits	Mnemonic
for (i = 0; i < transport_private_data_length; i++) { <b>private_data_byte</b> }	8	bslbf
if (adaptation_field_extension_flag == '1') { <b>adaptation_field_extension_length</b> <b>ltw_flag</b> <b>piecewise_rate_flag</b> <b>seamless_splice_flag</b> <b>af_descriptor_not_present_flag</b> <b>reserved</b> if (ltw_flag == '1') { <b>ltw_valid_flag</b> <b>ltw_offset</b> } if (piecewise_rate_flag == '1') { <b>reserved</b> <b>piecewise_rate</b> } if (seamless_splice_flag == '1') { <b>Splice_type</b> <b>DTS_next_AU[32..30]</b> <b>marker_bit</b> <b>DTS_next_AU[29..15]</b> <b>marker_bit</b> <b>DTS_next_AU[14..0]</b> <b>marker_bit</b> } if (af_descriptor_not_present_flag == '0') { for (i = 0; i < N1; i++) { af_descriptor() } } else { for (i = 0; i < N2; i++) { <b>reserved</b> } } } for (i = 0; i < N3; i++) { <b>stuffing_byte</b> }	8 1 1 1 1 4 1 15 2 22 4 3 1 15 1 1 15 1	uimsbf bslbf bslbf bslbf bslbf bslbf bslbf bslbf uimsbf bslbf uimsbf bslbf bslbf bslbf bslbf bslbf bslbf bslbf bslbf
<b>reserved</b>	8	bslbf
<b>stuffing_byte</b>	8	bslbf

#### 2.4.3.5 Semantic definition of fields in adaptation field

**adaptation\_field\_length** – The adaptation\_field\_length is an 8-bit field specifying the number of bytes in the adaptation\_field immediately following the adaptation\_field\_length. The value '0' is for inserting a single stuffing byte in the adaptation field of a transport stream packet. When the adaptation\_field\_control value is '11', the value of the adaptation\_field\_length shall be in the range 0 to 182. When the adaptation\_field\_control value is '10', the value of the adaptation\_field\_length shall be 183. For transport stream packets carrying PES packets, stuffing is needed when there is insufficient PES packet data to completely fill the transport stream packet payload bytes. Stuffing is accomplished by defining an adaptation field longer than the sum of the lengths of the data elements in it, so that the payload bytes remaining after the adaptation field exactly accommodates the available PES packet data. The extra space in the adaptation field is filled with stuffing bytes.

This is the only method of stuffing allowed for transport stream packets carrying PES packets. For transport stream packets carrying sections, an alternative stuffing method is described in 2.4.4.1.

**discontinuity\_indicator** – This is a 1-bit field which when set to '1' indicates that the discontinuity state is true for the current transport stream packet. When the discontinuity\_indicator is set to '0' or is not present, the discontinuity state is false. The discontinuity indicator is used to indicate two types of discontinuities, system time-base discontinuities and continuity\_counter discontinuities.

A system time-base discontinuity is indicated by the use of the discontinuity\_indicator in transport stream packets of a PID designated as a PCR\_PID (refer to 2.4.4.10). When the discontinuity state is true for a transport stream packet of a

PID designated as a PCR\_PID, the next PCR in a transport stream packet with that same PID represents a sample of a new system time clock for the associated program. The system time-base discontinuity point is defined to be the instant in time when the first byte of a packet containing a PCR of a new system time-base arrives at the input of the T-STD. The discontinuity\_indicator shall be set to '1' in the packet in which the system time-base discontinuity occurs. The discontinuity\_indicator bit may also be set to '1' in transport stream packets of the same PCR\_PID prior to the packet which contains the new system time-base PCR. In this case, once the discontinuity\_indicator has been set to '1', it shall continue to be set to '1' in all transport stream packets of the same PCR\_PID up to and including the transport stream packet which contains the first PCR of the new system time-base. After the occurrence of a system time-base discontinuity, no fewer than two PCRs for the new system time-base shall be received before another system time-base discontinuity can occur. Further, except when trick mode status is true, data from no more than two system time-bases shall be present in the set of T-STD buffers for one program at any time.

Prior to the occurrence of a system time-base discontinuity, the first byte of a transport stream packet which contains a PTS or DTS which refers to the new system time-base shall not arrive at the input of the T-STD. After the occurrence of a system time-base discontinuity, the first byte of a transport stream packet which contains a PTS or DTS which refers to the previous system time-base shall not arrive at the input of the T-STD.

A continuity\_counter discontinuity is indicated by the use of the discontinuity\_indicator in any transport stream packet. When the discontinuity state is true in any transport stream packet of a PID not designated as a PCR\_PID, the continuity\_counter in that packet may be discontinuous with respect to the previous transport stream packet of the same PID. When the discontinuity state is true in a transport stream packet of a PID that is designated as a PCR\_PID, the continuity\_counter may only be discontinuous in the packet in which a system time-base discontinuity occurs. A continuity counter discontinuity point occurs when the discontinuity state is true in a transport stream packet and the continuity\_counter in the same packet is discontinuous with respect to the previous transport stream packet of the same PID. A continuity counter discontinuity point shall occur at most one time from the initiation of the discontinuity state until the conclusion of the discontinuity state. Furthermore, for all PIDs that are not designated as PCR\_PIDs, when the discontinuity\_indicator is set to '1' in a packet of a specific PID, the discontinuity\_indicator may be set to '1' in the next transport stream packet of that same PID, but shall not be set to '1' in three consecutive transport stream packets of that same PID.

For the purpose of this clause, an elementary stream access point is defined as follows:

- ISO/IEC 11172-2 video and Rec. ITU-T H.262 | ISO/IEC 13818-2 video – The first byte of a video sequence header.
- ISO/IEC 14496-2 visual – The first byte of the visual object sequence header.
- AVC video streams conforming to one or more profiles defined in Annex A of Rec. ITU-T H.264 | ISO/IEC 14496-10 – The first byte of an AVC access unit. The SPS and PPS parameter sets referenced in this and all subsequent AVC access units in the coded video stream shall be provided after this access point in the byte stream and prior to their activation.
- Video sub-bitstreams of AVC video streams conforming to one or more profiles defined in Annex G of Rec. ITU-T H.264 | ISO/IEC 14496-10 – The first byte of an SVC dependency representation is an elementary stream access point if the following conditions are met:
  - The subset sequence parameter sets and picture parameter sets referenced in this and all subsequent SVC dependency representation in the video sub-bitstream shall be provided after this access point in the byte stream and prior to their activation.
  - If this SVC video sub-bitstream access point requires the elementary stream access point of the same AVC access unit, if any, contained in the corresponding elementary stream that needs to be present in decoding order before decoding the elementary stream associated with this elementary stream access point, then the corresponding elementary stream shall also include an elementary stream access point.

NOTE 1 – If the hierarchy descriptor is present for this SVC video sub-bitstream then the video sub-bitstream of which the hierarchy\_layer\_index equals the hierarchy\_embedded\_layer\_index of this SVC sub-bitstream should have an elementary stream access point in the same access unit.
- MVC video sub-bitstreams of AVC video streams conforming to one or more profiles defined in Annex H of Rec. ITU-T H.264 | ISO/IEC 14496-10 – The first byte of an MVC view-component subset is an elementary stream access point if the following two conditions are met:
  - The subset sequence parameter sets and picture parameter sets referenced in this and all subsequent MVC view-component subsets in the MVC video sub-bitstream shall be provided after this access point in the byte stream and prior to their activation.
  - If this MVC video sub-bitstream access point requires the elementary stream access point of the same AVC access unit, if any, contained in the corresponding elementary stream that needs to be present in decoding order before decoding the elementary stream associated with this elementary stream

access point, then the corresponding elementary stream shall also include an elementary stream access point.

NOTE 2 – If the hierarchy descriptor is present for this MVC video sub-bitstream, then the MVC video sub-bitstream of which the `hierarchy_layer_index` equals the `hierarchy_embedded_layer_index` of this MVC sub-bitstream should have an elementary stream access point in this same access unit.

- Audio – The first byte of an audio frame.
  - ISO/IEC 14496-17 text stream – The first byte of a text access unit. In case in-band sample descriptions are used, each in-band sample description shall be provided in the ISO/IEC 14496-17 stream after this access point and prior to its use by an access unit.
  - HEVC video streams or HEVC temporal video sub-bitstreams – The first byte of an HEVC access unit. The VPS, SPS and PPS parameter sets, as defined in Rec. ITU-T H.265 | ISO/IEC 23008-2, referenced in this and all subsequent HEVC access units in the HEVC video sequence shall be provided after this access point in the byte stream and prior to their activation.
  - MVCD video sub-bitstreams of AVC video streams conforming to one or more profiles defined in Annex I of Rec. ITU-T H.264 | ISO/IEC 14496-10 – The first byte of an MVCD view-component subset is an elementary stream access point if the following two conditions are met:
    - The subset sequence parameter sets and picture parameter sets referenced in this and all subsequent MVCD view-component subsets in the MVCD video sub-bitstream shall be provided after this access point in the byte stream and prior to their activation.
    - If this MVCD video sub-bitstream access point requires the elementary stream access point of the same AVC access unit, if any, contained in the corresponding elementary stream that needs to be present in decoding order before decoding the elementary stream associated with this elementary stream access point, then the corresponding elementary stream shall also include an elementary stream access point.
- NOTE 3 – If the hierarchy descriptor is present for this MVCD video sub-bitstream, then the MVCD video sub-bitstream of which the `hierarchy_layer_index` equals the `hierarchy_embedded_layer_index` of this MVCD sub-bitstream should have an elementary stream access point in this same access unit.
- VVC video streams or VVC temporal video sub-bitstreams – The first byte of a VVC access unit. The DCI NAL unit (if present) and VPS (if present), SPS and PPS parameter sets, as defined in Rec. ITU-T H.266 | ISO/IEC 23090-3, referenced in this and all subsequent VVC access units in the VVC video sequence shall be provided after this access point in the byte stream and prior to being referred to.
  - EVC video streams or EVC temporal video sub-bitstreams – The first byte of an EVC access unit. The APS, SPS and PPS, as defined in ISO/IEC 23094-1, referenced in this and all subsequent EVC access units in the EVC video sequence shall be provided after this access point in the byte stream and prior to their activation.

After a continuity counter discontinuity in a transport packet which is designated as containing elementary stream data, the first byte of elementary stream data in a transport stream packet of the same PID shall be the first byte of an elementary stream access point. In the case of ISO/IEC 11172-2, or Rec. ITU-T H.262 | ISO/IEC 13818-2 or ISO/IEC 14496-2 video, the first byte of an elementary stream access point may also be the first byte of a `sequence_end_code` followed by an elementary stream access point.

Each transport stream packet which contains elementary stream data with a PID not designated as a PCR\_PID, and in which a continuity counter discontinuity point occurs, and in which a PTS or DTS occurs, shall arrive at the input of the T-STD after the system time-base discontinuity for the associated program occurs. In the case where the discontinuity state is true, if two consecutive transport stream packets of the same PID occur which have the same `continuity_counter` value and have `adaptation_field_control` values set to '01' or '11', the second packet may be discarded. A transport stream shall not be constructed in such a way that discarding such a packet will cause the loss of PES packet payload data or transport stream section data.

After the occurrence of a `discontinuity_indicator` set to '1' in a transport stream packet which contains PSI information, a single discontinuity in the `version_number` of PSI sections may occur. At the occurrence of such a discontinuity, a version of the `TS_program_map_sections` of the appropriate program shall be sent with `section_length` = 13 and the `current_next_indicator` = 1, such that there are no `program_descriptors` and no elementary streams described. This shall then be followed by a version of the `TS_program_map_section` for each affected program with the `version_number` incremented by one and the `current_next_indicator` = 1, containing a complete program definition. This indicates a version change in PSI data.

**Random\_access\_indicator** – The `random_access_indicator` is a 1-bit field that indicates that the current transport stream packet, and possibly subsequent transport stream packets with the same PID, contain some information to aid random access at this point.

Specifically, when the bit is set to '1', the next PES packet to start in the payload of transport stream packets with the current PID shall contain an elementary stream access point as defined in the semantics for the discontinuity\_indicator field. In addition, in the case of video, a presentation timestamp shall be present for the first picture following the elementary stream access point.

In the case of audio, the presentation timestamp shall be present in the PES packet containing the first byte of the audio frame. In the PCR\_PID the random\_access\_indicator may only be set to '1' in a transport stream packet containing the PCR fields.

**Elementary\_stream\_priority\_indicator** – The elementary\_stream\_priority\_indicator is a 1-bit field. It indicates, among packets with the same PID, the priority of the elementary stream data carried within the payload of this transport stream packet. A '1' indicates that the payload has a higher priority than the payloads of other transport stream packets.

In the case of ISO/IEC 11172-2 or Rec. ITU-T H.262 | ISO/IEC 13818-2 or ISO/IEC 14496-2 video, this field may be set to '1' only if the payload contains one or more bytes from an intra-coded slice.

In the case of Rec. ITU-T H.264 | ISO/IEC 14496-10 video, this field may be set to '1' only if the payload contains one or more bytes from a slice with slice\_type set to 2, 4, 7, or 9.

A value of '0' indicates that the payload has the same priority as all other packets which do not have this bit set to '1'.

For MVC video sub-bitstreams or MVC base view sub-bitstreams of AVC video streams conforming to one or more profiles defined in Annex H of Rec. ITU-T H.264 | ISO/IEC 14496-10, this field may be set to '1' only if the payload contains one or more bytes from an anchor picture, indicated by the slice\_type equal to 2, 4, 7, or 9 and the anchor\_pic\_flag syntax element equal to 1 for all prefix NAL units and slice extension NAL units.

For MVCD video sub-bitstreams or MVCD base view sub-bitstreams of AVC video streams conforming to one or more profiles defined in Annex I of Rec. ITU-T H.264 | ISO/IEC 14496-10, this field may be set to '1' only if the payload contains one or more bytes from an anchor picture, indicated by the slice\_type equal to 2, 4, 7, or 9 and the anchor\_pic\_flag syntax element equal to 1 for all prefix NAL units and slice extension NAL units. In the case of HEVC video streams or HEVC temporal video sub-bitstreams or HEVC temporal video subsets, this field may be set to '1' only if the payload contains one or more bytes from a slice with slice\_type set to 2. A value of '0' indicates that the payload has the same priority as all other packets which do not have this bit set to '1'.

In the case of VVC video streams or VVC temporal video sub-bitstreams or VVC temporal video subsets, this field may be set to '1' only if the payload contains one or more bytes from a slice with slice\_type set to 2. A value of '0' indicates that the payload has the same priority as all other packets which do not have this bit set to '1'.

In the case of EVC video streams or EVC temporal video sub-bitstreams, this field may be set to '1' only if the payload contains one or more bytes from a slice with slice\_type set to 2. A value of '0' indicates that the payload has the same priority as all other packets which do not have this bit set to '1'.

**PCR\_flag** – The PCR\_flag is a 1-bit flag. A value of '1' indicates that the adaptation\_field contains a PCR field coded in two parts. A value of '0' indicates that the adaptation field does not contain any PCR field.

**OPCR\_flag** – The OPCR\_flag is a 1-bit flag. A value of '1' indicates that the adaptation\_field contains an OPCR field coded in two parts. A value of '0' indicates that the adaptation field does not contain any OPCR field.

**Splicing\_point\_flag** – The splicing\_point\_flag is a 1-bit flag. When set to '1', a splice\_countdown field shall be present in this adaptation field, specifying the occurrence of a splicing point. A value of '0' indicates that a splice\_countdown field is not present in the adaptation field.

**Transport\_private\_data\_flag** – The transport\_private\_data\_flag is a 1-bit flag. A value of '1' indicates that the adaptation field contains one or more private\_data bytes. A value of '0' indicates the adaptation field does not contain any private\_data bytes.

**Adaptation\_field\_extension\_flag** – The adaptation\_field\_extension\_flag is a 1-bit field which when set to '1' indicates the presence of an adaptation field extension. A value of '0' indicates that an adaptation field extension is not present in the adaptation field.

**Program\_clock\_reference\_base; program\_clock\_reference\_extension** – The program\_clock\_reference (PCR) is a 42-bit field coded in two parts. The first part, program\_clock\_reference\_base, is a 33-bit field whose value is given by PCR\_base(i), as given in equation 2-2. The second part, program\_clock\_reference\_extension, is a 9-bit field whose value is given by PCR\_ext(i), as given in equation 2-3. The PCR indicates the intended time of arrival of the byte containing the last bit of the program\_clock\_reference\_base at the input of the system target decoder.

**Original\_program\_clock\_reference\_base; original\_program\_clock\_reference\_extension** – The optional original program reference (OPCR) is a 42-bit field coded in two parts. These two parts, the base and the extension, are coded identically to the two corresponding parts of the PCR field. The presence of the OPCR is indicated by the OPCR\_flag.

The OPCR field shall be coded only in transport stream packets in which the PCR field is present. OPCR's are permitted in both single program and multiple program transport streams.

OPCR assists in the reconstruction of a single program transport stream from another transport stream. When reconstructing the original single program transport stream, the OPCR may be copied to the PCR field. The resulting PCR value is valid only if the original single program transport stream is reconstructed exactly in its entirety. This would include at least any PSI and private data packets which were present in the original transport stream and would possibly require other private arrangements. It also means that the OPCR must be an identical copy of its associated PCR in the original single program transport stream.

The OPCR is expressed as follows:

$$OPCR(i) = OPCR\_base(i) \times 300 + OPCR\_ext(i) \quad (2-8)$$

where:

$$OPCR\_base(i) = ((system\_clock\_frequency \times t(i)) \text{DIV} 300) \% 2^{33} \quad (2-9)$$

$$OPCR\_ext(i) = ((system\_clock\_frequency \times t(i)) \text{DIV} 1) \% 300 \quad (2-10)$$

The OPCR field is ignored by the decoder. The OPCR field shall not be modified by any multiplexor or decoder.

**Splice\_countdown** – The splice\_countdown is an 8-bit field, representing a value which may be positive or negative. A positive value specifies the remaining number of transport stream packets, of the same PID, following the associated transport stream packet until a splicing point is reached. Duplicate transport stream packets and transport stream packets which only contain adaptation fields are excluded. The splicing point is located immediately after the last byte of the transport stream packet in which the associated splice\_countdown field reaches zero. In the transport stream packet where the splice\_countdown reaches zero, the last data byte of the transport stream packet payload shall be the last byte of a coded audio frame or a coded picture. In the case of video, the corresponding access unit may or may not be terminated by a sequence\_end\_code. Transport stream packets with the same PID, which follow, may contain data from a different elementary stream of the same type.

The payload of the next transport stream packet of the same PID (duplicate packets and packets without payload being excluded) shall commence with the first byte of a PES packet. In the case of audio, the PES packet payload shall commence with an access point. In the case of video, the PES packet payload shall commence with an access point, or with a sequence\_end\_code, followed by an access point. Thus, the previous coded audio frame or coded picture aligns with the packet boundary, or is padded to make this so. Subsequent to the splicing point, the countdown field may also be present. When the splice\_countdown is a negative number whose value is minus n (–n), it indicates that the associated transport stream packet is the n-th packet following the splicing point (duplicate packets and packets without payload being excluded).

For the definition of an elementary stream access point, see the semantics of discontinuity\_indicator.

**Transport\_private\_data\_length** – The transport\_private\_data\_length is an 8-bit field specifying the number of private\_data bytes immediately following the transport\_private\_data\_length field. The number of private\_data bytes shall be such that private data does not extend beyond the adaptation field.

**Private\_data\_byte** – The private\_data\_byte is an 8-bit field that shall not be specified by ITU-T | ISO/IEC.

**Adaptation\_field\_extension\_length** – The adaptation\_field\_extension\_length is an 8-bit field. It indicates the number of bytes of the extended adaptation field data immediately following this field, including reserved bytes if present.

**Ltw\_flag** (legal time window\_flag) – This is a 1-bit field which when set to '1' indicates the presence of the ltw\_offset field.

**Piecewise\_rate\_flag** – This is a 1-bit field which when set to '1' indicates the presence of the piecewise\_rate field.

**Seamless\_splice\_flag** – This is a 1-bit flag which when set to '1' indicates that the splice\_type and DTS\_next\_AU fields are present. A value of '0' indicates that neither splice\_type nor DTS\_next\_AU fields are present. This field shall be set to '0' in transport stream packets in which the splicing\_point\_flag is set to '0'. Once it is set to '1' in a transport stream packet in which the splice\_countdown is positive, it shall be set to '1' in all the subsequent transport stream packets of the same PID that have the splicing\_point\_flag set to '1', until the packet in which the splice\_countdown reaches zero (including this packet).

When this flag is set, and if the elementary stream carried in this PID is not a Rec. ITU-T H.262 | ISO/IEC 13818-2 video stream, then the splice\_type field shall be set to '0000'. If the elementary stream carried in this PID is an Rec. ITU-T H.262 | ISO/IEC 13818-2 video stream, it shall fulfil the constraints indicated by the splice\_type value.

**Af\_descriptor\_not\_present\_flag** – This 1-bit field when set to '0' signals the presence of one or several af\_descriptor() constructs in the adaptation header. When this flag is set to '1' it indicates that the af\_descriptor() is not present in the adaptation header.

**Ltw\_valid\_flag** (legal time window\_valid\_flag) – This is a 1-bit field which when set to '1' indicates that the value of the ltw\_offset shall be valid. A value of '0' indicates that the value in the ltw\_offset field is undefined.

**Ltw\_offset** (legal time window offset) – This is a 15-bit field, the value of which is defined only if the ltw\_valid flag has a value of '1'. When defined, the legal time window offset is in units of  $(300/f_s)$  seconds, where  $f_s$  is the system clock frequency of the program that this PID belongs to, and fulfils:

$$offset = t_1(i) - t(i)$$

$$ltw\_offset = offset // 1$$

where  $i$  is the index of the first byte of this transport stream packet,  $offset$  is the value encoded in this field,  $t(i)$  is the arrival time of byte  $i$  in the T-STD, and  $t_1(i)$  is the upper bound in time of a time interval called the legal time window which is associated with this transport stream packet.

The legal time window has the property that if this transport stream is delivered to a T-STD starting at time  $t_1(i)$ , i.e., at the end of its legal time window, and all other transport stream packets of the same program are delivered at the end of their legal time windows, then:

- For video – The  $MB_n$  buffer for this PID in the T-STD shall contain less than 184 bytes of elementary stream data at the time the first byte of the payload of this transport stream packet enters it, and no buffer violations in the T-STD shall occur.
- For audio – The  $B_n$  buffer for this PID in the T-STD shall contain less than  $BS_{dec} + 1$  bytes of elementary stream data at the time the first byte of this transport stream packet enters it, and no buffer violations in the T-STD shall occur.

Depending on factors including the size of the buffer  $MB_n$  and the rate of data transfer between  $MB_n$  and  $EB_n$ , it is possible to determine another time  $t_0(i)$ , such that if this packet is delivered anywhere in the interval  $[t_0(i), t_1(i)]$ , no T-STD buffer violations will occur. This time interval is called the legal time window. The value of  $t_0$  is not defined in this Recommendation | International Standard.

The information in this field is intended for devices such as remultiplexers which may need this information in order to reconstruct the state of the buffers  $MB_n$ .

**piecewise\_rate** – The meaning of this 22-bit field is only defined when both the ltw\_flag and the ltw\_valid\_flag are set to '1'. When defined, it is a positive integer specifying a hypothetical bitrate  $R$  which is used to define the end times of the Legal Time Windows of transport stream packets of the same PID that follow this packet but do not include the legal\_time\_window\_offset field.

Assume that the first byte of this transport stream packet and the  $N$  following transport stream packets of the same PID have indices  $A_i, A_{i+1}, \dots, A_{i+N}$ , respectively, and that the  $N$  latter packets do not have a value encoded in the field legal\_time\_window\_offset. Then the values  $t_1(A_{i+j})$  shall be determined by:

$$t_1(A_{i+j}) = t_1(A_i) + j \times 188 \times 8 \text{ bits/byte} / R$$

where  $j$  goes from 1 to  $N$ .

All packets between this packet and the next packet of the same PID to include a legal\_time\_window\_offset field shall be treated as if they had the value:

$$offset = t_1(A_j) - t(A_j)$$

corresponding to the value  $t_1(\cdot)$  as computed by the formula above encoded in the legal\_time\_window\_offset field.  $t(j)$  is the arrival time of byte  $j$  in the T-STD.

The meaning of this field is not defined when it is present in a transport stream packet with no legal\_time\_window\_offset field.

**splice\_type** – This is a 4-bit field. From the first occurrence of this field onwards, it shall have the same value in all the subsequent transport stream packets of the same PID in which it is present, until the packet in which the splice\_countdown reaches zero (including this packet). If the elementary stream carried in that PID is not a Rec. ITU-T H.262 | ISO/IEC 13818-2 video stream, then this field shall have the value '1111' (unspecified). If the elementary stream carried in that

PID is a Rec. ITU-T H.262 | ISO/IEC 13818-2 video stream, then this field indicates the conditions that shall be respected by this elementary stream for splicing purposes. These conditions are defined as a function of profile, level and splice\_type in Table 2-7 through Table 2-20.

In these tables, a value for 'splice\_decoding\_delay' and 'max\_splice\_rate' means that the following conditions shall be satisfied by the video elementary stream:

- 1) The last byte of the coded picture ending in the transport stream packet in which the splice\_countdown reaches zero shall remain in the VBV buffer of the VBV model for an amount of time equal to (splice\_decoding\_delay  $t_{n+1} - t_n$ ), where for the purpose of this subclause:
  - n is the index of the coded picture ending in the transport stream packet in which the splice\_countdown reaches zero, i.e., the coded picture referred to above.
  - $t_n$  is defined in C.3.1 of Rec. ITU-T H.262 | ISO/IEC 13818-2.
  - ( $t_{n+1} - t_n$ ) is defined in C.9 through C.12 of Rec. ITU-T H.262 | ISO/IEC 13818-2.

NOTE 4 –  $t_n$  is the time when coded picture n is removed from the VBV buffer, and ( $t_{n+1} - t_n$ ) is the duration for which picture n is presented.
- 2) The VBV buffer of the VBV model shall not overflow if its input is switched at the splicing point to a stream of a constant rate equal to 'max\_splice\_rate' for an amount of time equal to 'splice\_decoding\_delay'.

**Table 2-7 – Splice parameters Table 1**  
**Simple Profile Main Level, Main Profile Main Level,**  
**SNR Profile Main Level (both layers),**  
**Spatial Profile High-1440 Level (base layer),**  
**High Profile Main Level (middle + base layers),**  
**Multi-view Profile Main Level (base layer) Video**

splice_type	Conditions
'0000'	splice_decoding_delay = 120 ms; max_splice_rate = $15.0 \times 10^6$ bit/s
'0001'	splice_decoding_delay = 150 ms; max_splice_rate = $12.0 \times 10^6$ bit/s
'0010'	splice_decoding_delay = 225 ms; max_splice_rate = $8.0 \times 10^6$ bit/s
'0011'	splice_decoding_delay = 250 ms; max_splice_rate = $7.2 \times 10^6$ bit/s
'0100' .. '1011'	Reserved
'1100' .. '1110'	User-defined
'1111'	unspecified

**Table 2-8 – Splice parameters Table 2**  
**Main Profile Low Level, SNR Profile Low Level (both layers),**  
**High Profile Main Level (base layer),**  
**Multi-view Profile Low Level (base layer) Video**

splice_type	Conditions
'0000'	splice_decoding_delay = 115 ms; max_splice_rate = $4.0 \times 10^6$ bit/s
'0001'	splice_decoding_delay = 155 ms; max_splice_rate = $3.0 \times 10^6$ bit/s
'0010'	splice_decoding_delay = 230 ms; max_splice_rate = $2.0 \times 10^6$ bit/s
'0011'	splice_decoding_delay = 250 ms; max_splice_rate = $1.8 \times 10^6$ bit/s
'0100' .. '1011'	Reserved
'1100' .. '1110'	User-defined
'1111'	unspecified

**Table 2-9 – Splice parameters Table 3**  
**Main Profile High-1440 Level, Spatial Profile High-1440 Level (all layers),**  
**High Profile High-1440 Level (middle + base layers),**  
**Multi-view Profile High-1440 Level (base layer) Video**

splice_type	Conditions
'0000'	splice_decoding_delay = 120 ms; max_splice_rate = $60.0 \times 10^6$ bit/s
'0001'	splice_decoding_delay = 160 ms; max_splice_rate = $45.0 \times 10^6$ bit/s
'0010'	splice_decoding_delay = 240 ms; max_splice_rate = $30.0 \times 10^6$ bit/s
'0011'	splice_decoding_delay = 250 ms; max_splice_rate = $28.5 \times 10^6$ bit/s
'0100' .. '1011'	Reserved
'1100' .. '1110'	User-defined
'1111'	unspecified

**Table 2-10 – Splice parameters Table 4**  
**Main Profile High Level, High Profile High-1440 Level (all layers),**  
**High Profile High Level (middle + base layers),**  
**Multi-view Profile High Level (base layer) Video**

splice_type	Conditions
'0000'	splice_decoding_delay = 120 ms; max_splice_rate = $80.0 \times 10^6$ bit/s
'0001'	splice_decoding_delay = 160 ms; max_splice_rate = $60.0 \times 10^6$ bit/s
'0010'	splice_decoding_delay = 240 ms; max_splice_rate = $40.0 \times 10^6$ bit/s
'0011'	splice_decoding_delay = 250 ms; max_splice_rate = $38.0 \times 10^6$ bit/s
'0100' .. '1011'	Reserved
'1100' .. '1110'	User-defined
'1111'	unspecified

**Table 2-11 – Splice parameters Table 5**  
**SNR Profile Low Level (base layer) Video**

splice_type	Conditions
'0000'	splice_decoding_delay = 115 ms; max_splice_rate = $3.0 \times 10^6$ bit/s
'0001'	splice_decoding_delay = 175 ms; max_splice_rate = $2.0 \times 10^6$ bit/s
'0010'	splice_decoding_delay = 250 ms; max_splice_rate = $1.4 \times 10^6$ bit/s
'0011' .. '1011'	Reserved
'1100' .. '1110'	User-defined
'1111'	unspecified

**Table 2-12 – Splice parameters Table 6**  
**SNR Profile Main Level (base layer) Video**

splice_type	Conditions
'0000'	splice_decoding_delay = 115 ms; max_splice_rate = $10.0 \times 10^6$ bit/s
'0001'	splice_decoding_delay = 145 ms; max_splice_rate = $8.0 \times 10^6$ bit/s
'0010'	splice_decoding_delay = 235 ms; max_splice_rate = $5.0 \times 10^6$ bit/s
'0011'	splice_decoding_delay = 250 ms; max_splice_rate = $4.7 \times 10^6$ bit/s
'0100' .. '1011'	Reserved
'1100' .. '1110'	User-defined
'1111'	unspecified

**Table 2-13 – Splice parameters Table 7**  
**Spatial Profile High-1440 Level (middle + base layers) Video**

splice_type	Conditions
'0000'	splice_decoding_delay = 120 ms; max_splice_rate = $40.0 \times 10^6$ bit/s
'0001'	splice_decoding_delay = 160 ms; max_splice_rate = $30.0 \times 10^6$ bit/s
'0010'	splice_decoding_delay = 240 ms; max_splice_rate = $20.0 \times 10^6$ bit/s
'0011'	splice_decoding_delay = 250 ms; max_splice_rate = $19.0 \times 10^6$ bit/s
'0100' .. '1011'	Reserved
'1100' .. '1110'	User-defined
'1111'	unspecified

**Table 2-14 – Splice parameters Table 8**  
**High Profile Main Level (all layers), High Profile High-1440 Level (base layer) Video**

splice_type	Conditions
'0000'	splice_decoding_delay = 120 ms; max_splice_rate = $20.0 \times 10^6$ bit/s
'0001'	splice_decoding_delay = 160 ms; max_splice_rate = $15.0 \times 10^6$ bit/s
'0010'	splice_decoding_delay = 240 ms; max_splice_rate = $10.0 \times 10^6$ bit/s
'0011'	splice_decoding_delay = 250 ms; max_splice_rate = $9.5 \times 10^6$ bit/s
'0100' .. '1011'	Reserved
'1100' .. '1110'	User-defined
'1111'	unspecified

**Table 2-15 – Splice parameters Table 9**  
**High Profile High Level (base layer),**  
**Multi-view Profile Main Level (both layers) Video**

splice_type	Conditions
'0000'	splice_decoding_delay = 120 ms; max_splice_rate = $25.0 \times 10^6$ bit/s
'0001'	splice_decoding_delay = 165 ms; max_splice_rate = $18.0 \times 10^6$ bit/s
'0010'	splice_decoding_delay = 250 ms; max_splice_rate = $12.0 \times 10^6$ bit/s
'0011' .. '1011'	Reserved
'1100' .. '1110'	User-defined
'1111'	unspecified

**Table 2-16 – Splice parameters Table 10  
High Profile High Level (all layers),  
Multi-view Profile High-1440 Level (both layers) Video**

splice_type	Conditions
'0000'	splice_decoding_delay = 120 ms; max_splice_rate = $100.0 \times 10^6$ bit/s
'0001'	splice_decoding_delay = 160 ms; max_splice_rate = $75.0 \times 10^6$ bit/s
'0010'	splice_decoding_delay = 240 ms; max_splice_rate = $50.0 \times 10^6$ bit/s
'0011'	splice_decoding_delay = 250 ms; max_splice_rate = $48.0 \times 10^6$ bit/s
'0100' .. '1011'	Reserved
'1100' .. '1110'	User-defined
'1111'	unspecified

**Table 2-17 – Splice parameters Table 11  
4:2:2 Profile Main Level Video**

splice_type	Conditions
'0000'	splice_decoding_delay = 45 ms; max_splice_rate = $50.0 \times 10^6$ bit/s
'0001'	splice_decoding_delay = 90 ms; max_splice_rate = $50.0 \times 10^6$ bit/s
'0010'	splice_decoding_delay = 180 ms; max_splice_rate = $50.0 \times 10^6$ bit/s
'0011'	splice_decoding_delay = 225 ms; max_splice_rate = $40.0 \times 10^6$ bit/s
'0100'	splice_decoding_delay = 250 ms; max_splice_rate = $36.0 \times 10^6$ bit/s
'0101' .. '1011'	Reserved
'1100' .. '1110'	User-defined
'1111'	unspecified

**Table 2-18 – Splice parameters Table 12  
Multi-view Profile Low Level (both layers) Video**

splice_type	Conditions
'0000'	splice_decoding_delay = 115 ms; max_splice_rate = $8.0 \times 10^6$ bit/s
'0001'	splice_decoding_delay = 155 ms; max_splice_rate = $6.0 \times 10^6$ bit/s
'0010'	splice_decoding_delay = 230 ms; max_splice_rate = $4.0 \times 10^6$ bit/s
'0011'	splice_decoding_delay = 250 ms; max_splice_rate = $3.7 \times 10^6$ bit/s
'0100' .. '1011'	Reserved
'1100' .. '1110'	User-defined
'1111'	unspecified

**Table 2-19 – Splice parameters Table 13  
Multi-view Profile High Level (both layers) Video**

splice_type	Conditions
'0000'	splice_decoding_delay = 120 ms; max_splice_rate = $130.0 \times 10^6$ bit/s
'0001'	splice_decoding_delay = 150 ms; max_splice_rate = $104.0 \times 10^6$ bit/s
'0010'	splice_decoding_delay = 240 ms; max_splice_rate = $65.0 \times 10^6$ bit/s
'0011'	splice_decoding_delay = 250 ms; max_splice_rate = $62.4 \times 10^6$ bit/s
'0100' .. '1011'	Reserved
'1100' .. '1110'	User-defined
'1111'	unspecified

**Table 2-20 – Splice parameters Table 14  
4:2:2 Profile High Level Video**

splice_type	Conditions
'0000'	splice_decoding_delay = 45 ms; max_splice_rate = $300.0 \times 10^6$ bit/s
'0001'	splice_decoding_delay = 90 ms; max_splice_rate = $300.0 \times 10^6$ bit/s
'0010' .. '0011'	Reserved
'0100'	splice_decoding_delay = 250 ms; max_splice_rate = $180.0 \times 10^6$ bit/s
'0101' .. '1011'	Reserved
'1100' .. '1110'	User-defined
'1111'	unspecified

**DTS\_next\_AU** (decoding time stamp next access unit) – This is a 33-bit field, coded in three parts. In the case of continuous and periodic decoding through this splicing point it indicates the decoding time of the first access unit following the splicing point. This decoding time is expressed in the time base which is valid in the transport stream packet in which the splice\_countdown reaches zero. From the first occurrence of this field onwards, it shall have the same value in all the subsequent transport stream packets of the same PID in which it is present, until the packet in which the splice\_countdown reaches zero (including this packet).

The af\_descriptor() field may carry one or more descriptors as defined in Annex U. For descriptors carrying information associated with specific access units of an elementary stream, the descriptor applies to the first access unit that starts in the PES packet immediately following this adaptation field. There may be several TS packets carrying no payload before the start of the PES, in which case these descriptors apply to the next TS packet with payload on the same PID.

The adaptation field shall contain only complete af\_descriptor() descriptors, i.e., a single descriptor is always contained in a single transport stream packet.

NOTE 5 – The adaptation field should remain relatively small; it is therefore recommended for large descriptors to use PES carriage as defined in Annex U.

**stuffing\_byte** – This is a fixed 8-bit value equal to '1111 1111' that can be inserted by the encoder. It is discarded by the decoder.

#### 2.4.3.6 PES packet

See Table 2-21.

**Table 2-21 – PES packet**

Syntax	No. of bits	Mnemonic
PES_packet() {		
<b>packet_start_code_prefix</b>	<b>24</b>	<b>bslbf</b>
<b>stream_id</b>	<b>8</b>	<b>uimsbf</b>
<b>PES_packet_length</b>	<b>16</b>	<b>uimsbf</b>
if (stream_id != program_stream_map		
&& stream_id != padding_stream		
&& stream_id != private_stream_2		
&& stream_id != ECM		
&& stream_id != EMM		
&& stream_id != program_stream_directory		
&& stream_id != DSMCC_stream		
&& stream_id != ITU-T Rec. H.222.1 type E stream) {		
'10'	<b>2</b>	<b>bslbf</b>
<b>PES_scrambling_control</b>	<b>2</b>	<b>bslbf</b>
<b>PES_priority</b>	<b>1</b>	<b>bslbf</b>
<b>data_alignment_indicator</b>	<b>1</b>	<b>bslbf</b>
<b>copyright</b>	<b>1</b>	<b>bslbf</b>
<b>original_or_copy</b>	<b>1</b>	<b>bslbf</b>
<b>PTS_DTS_flags</b>	<b>2</b>	<b>bslbf</b>
<b>ESCR_flag</b>	<b>1</b>	<b>bslbf</b>
<b>ES_rate_flag</b>	<b>1</b>	<b>bslbf</b>
<b>DSM_trick_mode_flag</b>	<b>1</b>	<b>bslbf</b>
<b>additional_copy_info_flag</b>	<b>1</b>	<b>bslbf</b>
<b>PES_CRC_flag</b>	<b>1</b>	<b>bslbf</b>
<b>PES_extension_flag</b>	<b>1</b>	<b>bslbf</b>
<b>PES_header_data_length</b>	<b>8</b>	<b>uimsbf</b>
if (PTS_DTS_flags == '10') {		
'0010'	<b>4</b>	<b>bslbf</b>

Table 2-21 – PES packet

Syntax	No. of bits	Mnemonic
PTS [32..30]	3	bslbf
marker_bit	1	bslbf
PTS [29..15]	15	bslbf
marker_bit	1	bslbf
PTS [14..0]	15	bslbf
marker_bit	1	bslbf
}		
if (PTS_DTS_flags == '11') {		
'0011'	4	bslbf
PTS [32..30]	3	bslbf
marker_bit	1	bslbf
PTS [29..15]	15	bslbf
marker_bit	1	bslbf
PTS [14..0]	15	bslbf
marker_bit	1	bslbf
'0001'	4	bslbf
DTS [32..30]	3	bslbf
marker_bit	1	bslbf
DTS [29..15]	15	bslbf
marker_bit	1	bslbf
DTS [14..0]	15	bslbf
marker_bit	1	bslbf
}		
if (ESCR_flag == '1') {		
reserved	2	bslbf
ESCR_base[32..30]	3	bslbf
marker_bit	1	bslbf
ESCR_base[29..15]	15	bslbf
marker_bit	1	bslbf
ESCR_base[14..0]	15	bslbf
marker_bit	1	bslbf
ESCR_extension	9	uimsbf
marker_bit	1	bslbf
}		
if (ES_rate_flag == '1') {		
marker_bit	1	bslbf
ES_rate	22	uimsbf
marker_bit	1	bslbf
}		
if (DSM_trick_mode_flag == '1') {		
trick_mode_control	3	uimsbf
if (trick_mode_control == fast_forward) {		
field_id	2	bslbf
intra_slice_refresh	1	bslbf
frequency_truncation	2	bslbf
}		
else if (trick_mode_control == slow_motion) {		
rep_cntrl	5	uimsbf
}		
else if (trick_mode_control == freeze_frame) {		
field_id	2	uimsbf
reserved	3	bslbf
}		
else if (trick_mode_control == fast_reverse) {		
field_id	2	bslbf
intra_slice_refresh	1	bslbf
frequency_truncation	2	bslbf
else if (trick_mode_control == slow_reverse) {		
rep_cntrl	5	uimsbf
}		
else		
reserved	5	bslbf
}		
if (additional_copy_info_flag == '1') {		
marker_bit	1	bslbf
additional_copy_info	7	bslbf
}		
if (PES_CRC_flag == '1') {		
previous_PES_packet_CRC	16	bslbf
}		

Table 2-21 – PES packet

Syntax	No. of bits	Mnemonic
if ( PES_extension_flag == '1' ) {		
<b>PES_private_data_flag</b>	1	bslbf
<b>pack_header_field_flag</b>	1	bslbf
<b>program_packet_sequence_counter_flag</b>	1	bslbf
<b>P-STD_buffer_flag</b>	1	bslbf
<b>reserved</b>	3	bslbf
<b>PES_extension_flag_2</b>	1	bslbf
if ( PES_private_data_flag == '1' ) {		
<b>PES_private_data</b>	128	bslbf
}		
if ( pack_header_field_flag == '1' ) {		
<b>pack_field_length</b>	8	uimsbf
pack_header()		
}		
if ( program_packet_sequence_counter_flag == '1' ) {		
<b>marker_bit</b>	1	bslbf
<b>program_packet_sequence_counter</b>	7	uimsbf
<b>marker_bit</b>	1	bslbf
<b>MPEG1_MPEG2_identifier</b>	1	bslbf
<b>original_stuff_length</b>	6	uimsbf
}		
if ( P-STD_buffer_flag == '1' ) {		
<b>'01'</b>	2	bslbf
<b>P-STD_buffer_scale</b>	1	bslbf
<b>P-STD_buffer_size</b>	13	uimsbf
}		
if ( PES_extension_flag_2 == '1' ) {		
<b>marker_bit</b>	1	bslbf
<b>PES_extension_field_length</b>	7	uimsbf
<b>stream_id_extension_flag</b>	1	bslbf
if ( stream_id_extension_flag == '0' ) {		
<b>stream_id_extension</b>	7	uimsbf
}		
else {		
<b>reserved</b>	6	bslbf
<b>tref_extension_flag</b>	1	bslbf
if ( tref_extension_flag == '0' ) {		
<b>reserved</b>	4	bslbf
<b>TREF[32..30]</b>	3	bslbf
<b>marker_bit</b>	1	bslbf
<b>TREF[29..15]</b>	15	bslbf
<b>marker_bit</b>	1	bslbf
<b>TREF[14..0]</b>	15	bslbf
<b>marker_bit</b>	1	bslbf
}		
}		
for ( i = 0; i < N3; i++ ) {		
<b>reserved</b>	8	bslbf
}		
}		
for ( i < 0; i < N1; i++ ) {		
<b>stuffing_byte</b>	8	bslbf
}		
for ( i < 0; i < N2; i++ ) {		
<b>PES_packet_data_byte</b>	8	bslbf
}		
}		
else if ( stream_id == program_stream_map		
stream_id == private_stream_2		
stream_id == ECM		
stream_id == EMM		
stream_id == program_stream_directory		
stream_id == DSMCC_stream		
stream_id == ITU-T Rec. H.222.1 type E stream ) {		
for ( i = 0; i < PES_packet_length; i++ ) {		
<b>PES_packet_data_byte</b>	8	bslbf
}		
}		
}		
else if ( stream_id == padding_stream ) {		

Table 2-21 – PES packet

Syntax	No. of bits	Mnemonic
<pre> for (i &lt; 0; i &lt; PES_packet_length; i++) {     padding_byte } </pre>	8	bslbf
<p>NOTE – The value N3 equals the byte count given by PES_extension_field_length minus the bytes which contain the stream_id_extension_flag and the occurring data elements in the if-else-construct after the stream_id_extension_flag.</p>		

2.4.3.7 Semantic definition of fields in PES packet

**packet\_start\_code\_prefix** – The packet\_start\_code\_prefix is a 24-bit code. Together with the stream\_id that follows it constitutes a packet start code that identifies the beginning of a packet. The packet\_start\_code\_prefix is the bit string '0000 0000 0000 0000 0000 0001' (0x000001).

**stream\_id** – In program streams, the stream\_id specifies the type and number of the elementary stream as defined by the stream\_id Table 2-22. In transport streams, the stream\_id may be set to any valid value which correctly describes the elementary stream type as defined in Table 2-22. In transport streams, the elementary stream type is specified in the program-specific information as specified in 2.4.4. For AVC video streams conforming to one or more profiles defined in Annex G of Rec. ITU-T H.264 | ISO/IEC 14496-10, all video sub-bitstreams of the same AVC video stream shall have the same stream\_id value. For AVC video streams conforming to one or more profiles defined in Annex H of Rec. ITU-T H.264 | ISO/IEC 14496-10, all MVC video sub-bitstreams of the same AVC video stream shall have the same stream\_id value. For AVC video streams conforming to one or more profiles defined in Annex I of Rec. ITU-T H.264 | ISO/IEC 14496-10, all MVCD video sub-bitstreams of the same AVC video stream shall have the same stream\_id value.

**PES\_packet\_length** – A 16-bit field specifying the number of bytes in the PES packet following the last byte of the field. A value of 0 indicates that the PES packet length is neither specified nor bounded and is allowed only in PES packets whose payload consists of bytes from a video elementary stream contained in transport stream packets.

**PES\_scrambling\_control** – The 2-bit PES\_scrambling\_control field indicates the scrambling mode of the PES packet payload. When scrambling is performed at the PES level, the PES packet header, including the optional fields when present, shall not be scrambled (see Table 2-23).

Table 2-22 – Stream\_id assignments

Stream_id	Note	stream coding
'1011 1100'	1	program_stream_map
'1011 1101'	2,9,10,11	private_stream_1
'1011 1110'		padding_stream
'1011 1111'	3	private_stream_2
'110x xxxx'		ISO/IEC 13818-3 or ISO/IEC 11172-3 or ISO/IEC 13818-7 or ISO/IEC 14496-3 or ISO/IEC 23008-3 audio stream number 'x xxxx'
'1110 xxxx'		Rec. ITU-T H.262   ISO/IEC 13818-2, ISO/IEC 11172-2, ISO/IEC 14496-2, Rec. ITU-T H.264   ISO/IEC 14496-10, Rec. ITU-T H.265   ISO/IEC 23008-2, Rec. ITU-T H.266   ISO/IEC 23090-3, ISO/IEC 23094-1 or ISO/IEC 23094-2 video stream number xxxx
'1111 0000'	3	ECM_stream
'1111 0001'	3	EMM_stream
'1111 0010'	5	Rec. ITU-T H.222.0   ISO/IEC 13818-1 Annex A or ISO/IEC 13818-6_DSMCC_stream
'1111 0011'	2	ISO/IEC_13522_stream
'1111 0100'	6	Rec. ITU-T H.222.1 type A
'1111 0101'	6	Rec. ITU-T H.222.1 type B
'1111 0110'	6	Rec. ITU-T H.222.1 type C
'1111 0111'	6	Rec. ITU-T H.222.1 type D
'1111 1000'	6	Rec. ITU-T H.222.1 type E
'1111 1001'	7	ancillary_stream
'1111 1010'		ISO/IEC 14496-1_SL-packetized_stream

Table 2-22 – Stream\_id assignments

Stream_id	Note	stream coding
'1111 1011'		ISO/IEC 14496-1_M4Mux_stream
'1111 1100'		metadata stream
'1111 1101'	8	extended_stream_id
'1111 1110'		reserved data stream
'1111 1111'	4	program_stream_directory

The notation x means that the values '0' or '1' are both permitted and results in the same stream type. The stream number is given by the values taken by the x's.

NOTE 1 – PES packets of type program\_stream\_map have unique syntax specified in 2.5.4.1.

NOTE 2 – PES packets of type private\_stream\_1 and ISO/IEC\_13552\_stream follow the same PES packet syntax as those for Rec. ITU-T H.262 | ISO/IEC 13818-2 video and ISO/IEC 13818-3 audio streams.

NOTE 3 – PES packets of type private\_stream\_2, ECM\_stream and EMM\_stream are similar to private\_stream\_1 except that no syntax is specified after PES\_packet\_length field.

NOTE 4 – PES packets of type program\_stream\_directory have a unique syntax specified in 2.5.5.

NOTE 5 – PES packets of type DSM-CC\_stream have a unique syntax specified in ISO/IEC 13818-6.

NOTE 6 – This stream\_id is associated with stream\_type 0x09 in Table 2-34.

NOTE 7 – This stream\_id is only used in PES packets, which carry data from a program\_stream or an ISO/IEC 11172-1 System Stream, in a transport stream (refer to 2.4.3.8).

NOTE 8 – The use of stream\_id 0xFD (extended\_stream\_id) identifies that this PES packet employs an extended syntax to permit additional stream types to be identified.

NOTE 9 – JPEG 2000 video streams (stream\_type = 0x21) are carried using the same PES packet syntax as private\_stream\_1.

NOTE 10 – Timeline and External Media Information streams (stream\_type = 0x27) are carried using the same PES packet syntax as private\_stream\_1.

NOTE 11 – JPEG XS video streams (stream\_type = 0x32) are carried using the same PES packet syntax as private\_stream\_1.

Table 2-23 – PES scrambling control values

Value	Description
'00'	Not scrambled
'01'	User-defined
'10'	User-defined
'11'	User-defined

**PES\_priority** – This is a 1-bit field indicating the priority of the payload in this PES packet. A '1' indicates a higher priority of the payload of the PES packet payload than a PES packet payload with this field set to '0'. A multiplexer can use the PES\_priority bit to prioritize its data within an elementary stream. This field shall not be changed by the transport mechanism.

**data\_alignment\_indicator** – This is a 1-bit flag. When set to a value of '1', it indicates that the PES packet header is immediately followed by the video syntax element or audio sync word indicated in the data\_stream\_alignment\_descriptor in 2.6.10 if this descriptor is present. If set to a value of '1' and the descriptor is not present, alignment as indicated in alignment\_type '01' in Table 2-53, Table 2-54 or Table 2-55 is required. When set to a value of '0', it is not defined whether any such alignment occurs or not.

**copyright** – This is a 1-bit field. When set to '1' it indicates that the material of the associated PES packet payload is protected by copyright. When set to '0' it is not defined whether the material is protected by copyright. A copyright descriptor described in 2.6.24 is associated with the elementary stream which contains this PES packet and the copyright flag is set to '1' if the descriptor applies to the material contained in this PES packet.

**original\_or\_copy** – This is a 1-bit field. When set to '1' the contents of the associated PES packet payload is an original. When set to '0' it indicates that the contents of the associated PES packet payload are a copy.

**PTS\_DTS\_flags** – This is a 2-bit field. When the PTS\_DTS\_flags field is set to '10', the PTS fields shall be present in the PES packet header. When the PTS\_DTS\_flags field is set to '11', both the PTS fields and DTS fields shall be present in

the PES packet header. When the PTS\_DTS\_flags field is set to '00' no PTS or DTS fields shall be present in the PES packet header. The value '01' is forbidden.

**ESCR\_flag** – A 1-bit flag, which when set to '1' indicates that ESCR base and extension fields are present in the PES packet header. When set to '0' it indicates that no ESCR fields are present.

**ES\_rate\_flag** – A 1-bit flag, which when set to '1' indicates that the ES\_rate field is present in the PES packet header. When set to '0' it indicates that no ES\_rate field is present.

**DSM\_trick\_mode\_flag** – A 1-bit flag, which when set to '1' it indicates the presence of an 8-bit trick mode field. When set to '0' it indicates that this field is not present.

**additional\_copy\_info\_flag** – A 1-bit flag, which when set to '1' indicates the presence of the additional\_copy\_info field. When set to '0' it indicates that this field is not present.

**PES\_CRC\_flag** – A 1-bit flag, which when set to '1' indicates that a CRC field is present in the PES packet. When set to '0' it indicates that this field is not present.

**PES\_extension\_flag** – A 1-bit flag, which when set to '1' indicates that an extension field exists in this PES packet header. When set to '0' it indicates that this field is not present.

**PES\_header\_data\_length** – An 8-bit field specifying the total number of bytes occupied by the optional fields and any stuffing bytes contained in this PES packet header. The presence of optional fields is indicated in the byte that precedes the PES\_header\_data\_length field.

**marker\_bit** – A marker\_bit is a 1-bit field that has the value '1'.

**PTS (presentation time stamp)** – Presentation times shall be related to decoding times as follows: The PTS is a 33-bit number coded in three separate fields. It indicates the time of presentation,  $tp_n(k)$ , in the system target decoder of a presentation unit  $k$  of elementary stream  $n$ . The value of PTS is specified in units of the period of the system clock frequency divided by 300 (yielding 90 kHz). The presentation time is derived from the PTS according to equation 2-11 below. Refer to 2.7.4 for constraints on the frequency of coding presentation timestamps.

$$PTS(k) = ((system\_clock\_frequency \times tp_n(k)) DIV 300) \% 2^{33} \quad (2-11)$$

where  $tp_n(k)$  is the presentation time of presentation unit  $P_n(k)$ .

In the case of audio, if a PTS is present in PES packet header it shall refer to the first access unit commencing in the PES packet. An audio access unit commences in a PES packet if the first byte of the audio access unit is present in the PES packet.

In the case of ISO/IEC 11172-2 video or ISO/IEC 14496-2 video, if a PTS is present in a PES packet header, it shall refer to the access unit containing the first picture start code that commences in this PES packet. A picture start code commences in a PES packet if the first byte of the picture start code is present in the PES packet. For I- and P-pictures in non-low\_delay sequences and in the case when there is no decoding discontinuity between access units (aUs)  $k$  and  $k'$ , the presentation time  $tp_n(k)$  shall be equal to the decoding time  $t_{dn}(k')$  of the next transmitted I- or P-picture (refer to 2.7.5). If there is a decoding discontinuity, or the stream ends, the difference between  $tp_n(k)$  and  $t_{dn}(k)$  shall be the same as if the original stream had continued without a discontinuity and without ending.

NOTE 1 – A low\_delay sequence is an ISO/IEC 14496-2 video sequence in which the low\_delay flag is set to '1' (refer to 6.2.3 of ISO/IEC 14496-2).

For Rec. ITU-T H.262 | ISO/IEC 13818-2 video, if a PTS is present in a PES packet header, it shall refer to the access unit containing the first picture start code that commences in this PES packet. A picture start code commences in a PES packet if the first byte of the picture start code is present in the PES packet. For I- and P-coded frames in non-low\_delay sequences and in the case when there is no decoding discontinuity between access units (aUs)  $k$  and  $k'$ , the presentation time  $tp_n(k)$  shall be equal to the decoding time  $t_{dn}(k')$  of the next transmitted I- or P-coded frame (refer to 2.7.5). If there is a decoding discontinuity, or the stream ends, the difference between  $tp_n(k)$  and  $t_{dn}(k)$  shall be the same as if the original stream had continued without a discontinuity and without ending.

NOTE 2 – A low\_delay sequence is an Rec. ITU-T H.262 | ISO/IEC 13818-2 video sequence in which the low\_delay flag is set to '1' (refer to 6.2.2.3 of Rec. ITU-T H.262 | ISO/IEC 13818-2). Also note that for field pictures the presentation time refers to the first field picture of the coded frame.

For AVC video streams conforming to one or more profiles defined in Annex A of Rec. ITU-T H.264 | ISO/IEC 14496-10 video, if a PTS is present in the PES packet header, it shall refer to the first AVC access unit that commences in this PES packet. An AVC access unit commences in a PES packet if the first byte of the AVC access unit is present in the PES packet. To achieve consistency between the STD model and the HRD model defined in Annex C of Rec. ITU-T H.264 | ISO/IEC 14496-10, for each decoded AVC access unit, the PTS value in the STD shall, within the accuracy of their

respective clocks, indicate the same instant in time as the nominal DPB output time in the HRD, defined herein as  $t_{o,n,dpb}(n) = t_{r,n}(n) + t_c * dpb\_output\_delay(n)$ , where  $t_{r,n}(n)$ ,  $t_c$ , and  $dpb\_output\_delay(n)$  are defined as in Annex C of Rec. ITU-T H.264 | ISO/IEC 14496-10.

For video sub-bitstreams of AVC video streams conforming to one or more profiles defined in Annex G of Rec. ITU-T H.264 | ISO/IEC 14496-10, if a PTS is present in the PES packet header, it shall refer to the first SVC dependency representation that commences in this PES packet. An SVC dependency representation commences in a PES packet if the first byte of the SVC dependency representation is present in the PES packet. To achieve consistency between the STD model and the HRD model defined in Annex C of Rec. ITU-T H.264 | ISO/IEC 14496-10, for each re-assembled and decoded AVC access unit, the PTS value in the STD shall, within the accuracy of their respective clocks, indicate the same instant in time as the nominal DPB output time in the HRD, defined herein as  $t_{o,n,dpb}(n) = t_{r,n}(n) + t_c * dpb\_output\_delay(n)$ , where  $t_{r,n}(n)$ ,  $t_c$ , and  $dpb\_output\_delay(n)$  are defined as in Annex C of Rec. ITU-T H.264 | ISO/IEC 14496-10.

NOTE 3 – Different clocks may be used for derivation of PTS and  $t_{o,n,dpb}(n)$ .

For MVC video sub-bitstreams, MVC base view sub-bitstream or AVC video sub-bitstream of MVC of AVC video streams conforming to one or more profiles defined in Annex H of Rec. ITU-T H.264 | ISO/IEC 14496-10, if a PTS is present in the PES packet header, it shall refer to the first MVC view-component subset that commences in this PES packet. An MVC view-component subset commences in a PES packet if the first byte of the MVC view-component subset is present in the PES packet. To achieve consistency between the STD model and the HRD model defined in Annex C of Rec. ITU-T H.264 | ISO/IEC 14496-10, for each re-assembled and decoded AVC access unit, the PTS value in the STD shall, within the accuracy of their respective clocks, indicate the same instant in time as the nominal DPB output time in the HRD, defined herein as  $t_{o,n,dpb}(n) = t_{r,n}(n) + t_c * dpb\_output\_delay(n)$ , where  $t_{r,n}(n)$ ,  $t_c$ , and  $dpb\_output\_delay(n)$  are defined as in Annex C of Rec. ITU-T H.264 | ISO/IEC 14496-10.

In the case of an ISO/IEC 14496-17 text stream, if a PTS is present in PES packet header, it shall refer to the first text access unit commencing in the PES packet. A text access unit commences in a PES packet if the first byte of the text access unit is present in the PES packet.

For MVCD video sub-bitstreams, MVCD base view sub-bitstream or AVC video sub-bitstream of MVCD of AVC video streams conforming to one or more profiles defined in Annex I of Rec. ITU-T H.264 | ISO/IEC 14496-10, if a PTS is present in the PES packet header, it shall refer to the first MVCD view-component subset that commences in this PES packet. An MVCD view-component subset commences in a PES packet if the first byte of the MVCD view-component subset is present in the PES packet. To achieve consistency between the STD model and the HRD model defined in Annex C of Rec. ITU-T H.264 | ISO/IEC 14496-10, for each re-assembled and decoded AVC access unit, the PTS value in the STD shall, within the accuracy of their respective clocks, indicate the same instant in time as the nominal DPB output time in the HRD, defined herein as  $t_{o,n,dpb}(n) = t_{r,n}(n) + t_c * dpb\_output\_delay(n)$ , where  $t_{r,n}(n)$ ,  $t_c$ , and  $dpb\_output\_delay(n)$  are defined as in Annex C of Rec. ITU-T H.264 | ISO/IEC 14496-10.

The presentation time  $t_{pn}(k)$  shall be equal to the decoding time  $t_{dn}(k)$  for:

- audio access units;
- access units in Rec. ITU-T H.262 | ISO/IEC 13818-2 or ISO/IEC 14496-2 low delay video sequences;
- B-pictures in ISO/IEC 11172-2, Rec. ITU-T H.262 | ISO/IEC 13818-2 or ISO/IEC 14496-2 video streams.
- text access units in ISO/IEC 14496-17.

If there is filtering in audio, it is assumed by the system model that filtering introduces no delay, hence the sample referred to by PTS at encoding is the same sample referred to by PTS at decoding. In the case of scalable coding refer to 2.7.6.

For HEVC video streams, HEVC temporal video sub-bitstreams and HEVC temporal video subsets, if a PTS is present in the PES packet header, it shall refer to the first HEVC access unit that commences in this PES packet. For HEVC video sub-partitions, if a PTS is present in the PES packet header, it shall refer to the first HEVC layer component that commences in this PES packet. An HEVC layer component commences in a PES packet if the first byte of the HEVC layer component is present in the PES packet. To achieve consistency between the STD model and the HRD model defined in Annex C of Rec. ITU-T H.265 | ISO/IEC 23008-2, for each HEVC access unit the PTS value in the STD shall, within the accuracy of their respective clocks, indicate the same instant in time as the nominal DPB output time in the HRD, as defined in Annex C of Rec. ITU-T H.265 | ISO/IEC 23008-2.

For VVC video streams, VVC temporal video sub-bitstreams and VVC temporal video subsets, if a PTS is present in the PES packet header, it shall refer to the first VVC access unit that commences in this PES packet. To achieve consistency between the STD model and the HRD model defined in Annex C of Rec. ITU-T H.266 | ISO/IEC 23090-3, for each VVC access unit the PTS value in the STD shall, within the accuracy of their respective clocks, indicate the same instant in time as the nominal DPB output time in the HRD, as defined in Annex C of Rec. ITU-T H.266 | ISO/IEC 23090-3.

For EVC video streams and EVC temporal video sub-bitstreams, if a PTS is present in the PES packet header, it shall refer to the first and only EVC access unit that commences in this PES packet. To achieve consistency between the STD

model and the HRD model defined in Annex C of ISO/IEC 23094-1, for each EVC access unit the PTS value in the STD shall, within the accuracy of their respective clocks, indicate the same instant in time as the nominal DPB output time in the HRD, as defined in Annex C of ISO/IEC 23094-1.

For LCEVC video streams, the PTS shall be present in the PES packet header, and it shall refer to only one LCEVC access unit that commences in this PES packet. To achieve consistency between the STD model and the HRD model defined in Annex C of ISO/IEC 23094-2, for each LCEVC access unit the PTS value in the STD shall, within its accuracy, indicate the same instant in time as the nominal DPB output time in the HRD, as defined in Annex C of ISO/IEC 23094-2.

**DTS (decoding time stamp)** – The DTS is a 33-bit number coded in three separate fields. It indicates the decoding time,  $td_n(j)$ , in the system target decoder of an access unit  $j$  of elementary stream  $n$ . The value of DTS is specified in units of the period of the system clock frequency divided by 300 (yielding 90 kHz). The decoding time derived from the DTS according to equation 2-12 below:

$$DTS(j) = ((system\_clock\_frequency \times td_n(j)) \text{DIV } 300) \% 2^{33} \quad (2-12)$$

where  $td_n(j)$  is the decoding time of access unit  $A_n(j)$ .

In the case of ISO/IEC 11172-2 video, Rec. ITU-T H.262 | ISO/IEC 13818-2 video, or ISO/IEC 14496-2 video, if a DTS is present in a PES packet header, it shall refer to the access unit containing the first picture start code that commences in this PES packet. A picture start code commences in a PES packet if the first byte of the picture start code is present in the PES packet.

For AVC video streams conforming to one or more profiles defined in Annex A of Rec. ITU-T H.264 | ISO/IEC 14496-10 video, if a DTS is present in the PES packet header, it shall refer to the first AVC access unit that commences in this PES packet. An AVC access unit commences in a PES packet if the first byte of the AVC access unit is present in the PES packet. To achieve consistency between the STD model and the HRD model defined in Annex C of Rec. ITU-T H.264 | ISO/IEC 14496-10, for each AVC access unit the DTS value in the STD shall, within the accuracy of their respective clocks, indicate the same instant in time as the nominal CPB removal time  $t_{r,n}(n)$  in the HRD, as defined in Annex C of Rec. ITU-T H.264 | ISO/IEC 14496-10.

For video sub-bitstreams of AVC video streams conforming to one or more profiles defined in Annex G of Rec. ITU-T H.264 | ISO/IEC 14496-10, if a DTS is present in the PES packet header, it shall refer to the first SVC dependency representation that commences in this PES packet. An SVC dependency representation commences in a PES packet if the first byte of the SVC dependency representation is present in the PES packet. To achieve consistency between the STD model and the HRD model defined in Annex C of Rec. ITU-T H.264 | ISO/IEC 14496-10, for each re-assembled AVC access unit the DTS value in the STD shall, within the accuracy of their respective clocks, indicate the same instant in time as the nominal CPB removal time  $t_{r,n}(n)$  in the HRD, as defined in Annex C of Rec. ITU-T H.264 | ISO/IEC 14496-10.

For MVC video sub-bitstreams of AVC video streams conforming to one or more profiles defined in Annex H of Rec. ITU-T H.264 | ISO/IEC 14496-10, if a DTS is present in the PES packet header, it shall refer to the first MVC view-component subset that commences in this PES packet. An MVC view-component subset commences in a PES packet if the first byte of the MVC view-component subset is present in the PES packet. To achieve consistency between the STD model and the HRD model defined in Annex C of Rec. ITU-T H.264 | ISO/IEC 14496-10, for each re-assembled AVC access unit the DTS value in the STD shall, within the accuracy of their respective clocks, indicate the same instant in time as the nominal CPB removal time  $t_{r,n}(n)$  in the HRD, as defined in Annex C of Rec. ITU-T H.264 | ISO/IEC 14496-10.

NOTE 4 – Different clocks may be used for derivation of DTS and  $t_{r,n}(n)$ .

In the case of scalable coding refer to 2.7.6.

For HEVC video streams, HEVC temporal video sub-bitstreams and HEVC temporal video subsets, if a DTS is present in the PES packet header, it shall refer to the first HEVC access unit that commences in this PES packet. For HEVC video sub-partitions, if a DTS is present in the PES packet header, it shall refer to the first HEVC layer component that commences in this PES packet. An HEVC layer component commences in a PES packet if the first byte of the HEVC layer component is present in the PES packet. To achieve consistency between the STD model and the HRD model defined in Annex C of Rec. ITU-T H.265 | ISO/IEC 23008-2, for each HEVC access unit the DTS value in the STD shall, within the accuracy of their respective clocks, indicate the same instant in time as the nominal CPB removal time in the HRD, as defined in Annex C of Rec. ITU-T H.265 | ISO/IEC 23008-2.

For MVCD video sub-bitstreams of AVC video streams conforming to one or more profiles defined in Annex I of Rec. ITU-T H.264 | ISO/IEC 14496-10, if a DTS is present in the PES packet header, it shall refer to the first MVCD view-component subset that commences in this PES packet. An MVCD view-component subset commences in a PES packet if the first byte of the MVCD view-component subset is present in the PES packet. To achieve consistency between the STD model and the HRD model defined in Annex C of Rec. ITU-T H.264 | ISO/IEC 14496-10, for each re-assembled

AVC access unit the DTS value in the STD shall, within the accuracy of their respective clocks, indicate the same instant in time as the nominal CPB removal time  $t_{r,n}(n)$  in the HRD, as defined in Annex C of Rec. ITU-T H.264 | ISO/IEC 14496-10.

For VVC video streams, VVC temporal video sub-bitstreams and VVC temporal video subsets, if a DTS is present in the PES packet header, it shall refer to the first VVC access unit that commences in this PES packet. To achieve consistency between the STD model and the HRD model defined in Annex C of Rec. ITU-T H.266 | ISO/IEC 23090-3, for each VVC access unit the DTS value in the STD shall, within the accuracy of their respective clocks, indicate the same instant in time as the nominal CPB removal time in the HRD, as specified in Annex C of Rec. ITU-T H.266 | ISO/IEC 23090-3.

For EVC video streams and EVC temporal video sub-bitstreams, if a DTS is present in the PES packet header, it shall refer to the first and only EVC access unit that commences in this PES packet. To achieve consistency between the STD model and the HRD model defined in Annex C of ISO/IEC 23094-1, for the  $n$ -th EVC access unit the DTS value in the STD shall, within the accuracy of their respective clocks, indicate the same instant in time as the nominal CPB removal time  $t_{r,n}(n)$  in the HRD, as defined in Annex C of Rec. ISO/IEC 23094-1.

For LCEVC video streams, the DTS shall not be present in the PES packet header because the LCEVC decoding process is strictly in presentation order. This restriction on the strict coincidence of decoding order and presentation order of the access units refers exclusively to the LCEVC video stream. On the other hand, the base video stream that the LCEVC video stream enhances has no such restriction, which means that in this case the decoding order and the presentation order can be different.

**ESCR\_base; ESCR\_extension** – The elementary stream clock reference is a 42-bit field coded in two parts. The first part, *ESCR\_base*, is a 33-bit field whose value is given by  $ESCR\_base(i)$ , as given in equation 2-14. The second part, *ESCR\_ext*, is a 9-bit field whose value is given by  $ESCR\_ext(i)$ , as given in equation 2-15. The ESCR field indicates the intended time of arrival of the byte containing the last bit of the *ESCR\_base* at the input of the PES-STD for PES streams (refer to 2.5.2.4).

Specifically:

$$ESCR(i) = ESCR\_base(i) \times 300 + ESCR\_ext(i) \quad (2-13)$$

where:

$$ESCR\_base(i) = ((system\_clock\_frequency \times t(i)) \text{ DIV } 300) \% 2^{33} \quad (2-14)$$

$$ESCR\_ext(i) = ((system\_clock\_frequency \times t(i)) \text{ DIV } 1) \% 300 \quad (2-15)$$

The ESCR and *ES\_rate* field (refer to semantics immediately following) contain timing information relating to the sequence of PES streams. These fields shall satisfy the constraints defined in 2.7.3.

**ES\_rate (elementary stream rate)** – The *ES\_rate* field is a 22-bit unsigned integer specifying the rate at which the system target decoder receives bytes of the PES packet in the case of a PES stream. The *ES\_rate* is valid in the PES packet in which it is included and in subsequent PES packets of the same PES stream until a new *ES\_rate* field is encountered. The value of the *ES\_rate* is measured in units of 50 bytes/second. The value '0' is forbidden. The value of the *ES\_rate* is used to define the time of arrival of bytes at the input of a P-STD for PES streams defined in 2.5.2.4. The value encoded in the *ES\_rate* field may vary from PES\_packet to PES\_packet.

**trick\_mode\_control** – A 3-bit field that indicates which trick mode is applied to the associated video stream (see Table 2-24). In cases of other types of elementary streams, the meanings of this field and those defined by the following five bits are undefined. For the definition of *trick\_mode* status, refer to the trick mode section of 2.4.2.4.

When *trick\_mode* status is false, the number of times  $N$ , a picture is output by the decoding process for progressive sequences, is specified for each picture by the *repeat\_first\_field* and *top\_field\_first* fields in the case of Rec. ITU-T H.262 | ISO/IEC 13818-2 video, and is specified through the sequence header in the case of ISO/IEC 11172-2 Video.

For interlaced sequences, when *trick\_mode* status is false, the number of times  $N$ , a picture is output by the decoding process for progressive sequences, is specified for each picture by the *repeat\_first\_field* and *progressive\_frame* fields in the case of Rec. ITU-T H.262 | ISO/IEC 13818-2 video.

When *trick\_mode* status is true, the number of times that a picture shall be displayed depends on the value of  $N$ .

When the value of this field changes or *trick\_mode* operations cease, any combination of the following may occur:

- discontinuity in the time base;
- decoding discontinuity;

- continuity counter discontinuity.

Table 2-24 – Trick mode control values

Value	Description
'000'	Fast forward
'001'	Slow motion
'010'	Freeze frame
'011'	Fast reverse
'100'	Slow reverse
'101' .. '111'	Reserved

In the context of trick mode, the non-normal speed of decoding and presentation may cause the values of certain fields defined in video elementary stream data to be incorrect. Likewise, the semantic constraint on the slice structure may be invalid. The video syntax elements to which this exception applies are:

- bit\_rate;
- vbv\_delay;
- repeat\_first\_field;
- v\_axis\_positive;
- field\_sequence;
- subcarrier;
- burst\_amplitude;
- subcarrier\_phase.

A decoder cannot rely on the values encoded in these fields when in trick mode.

Decoders are not normatively required to decode the `trick_mode_control` field. However, the following normative requirements shall apply to decoders that do decode the `trick_mode_control` field.

**fast forward** – The value '000', in the `trick_mode_control` field. When this value is present it indicates a fast forward video stream and defines the meaning of the following five bits in the PES packet header. The `intra_slice_refresh` bit may be set to '1' indicating that there may be missing macroblocks which the decoder may replace with co-sited macroblocks of previously decoded pictures. The `field_id` field, defined in Table 2-25, indicates which field or fields should be displayed. The `frequency_truncation` field indicates that a restricted set of coefficients may be included. The meaning of the values of this field are shown in Table 2-26.

**slow motion** – The value '001', in the `trick_mode_control` field. When this value is present it indicates a slow motion video stream and defines the meaning of the following five bits in the PES packet header. In the case of progressive sequences, the picture should be displayed  $N \times \text{rep\_cntrl}$  times, where  $N$  is defined above.

In the case of ISO/IEC 11172-2 video and Rec. ITU-T H.262 | ISO/IEC 13818-2 video progressive sequences, the picture should be displayed for  $N \times \text{rep\_cntrl}$  picture duration.

In the case of Rec. ITU-T H.262 | ISO/IEC 13818-2 interlaced sequences, the picture should be displayed for  $N \times \text{rep\_cntrl}$  field duration. If the picture is a frame picture, the first field to be displayed is the top field if `top_field_first` is 1, and the bottom field if `top_field_first` is '0' (refer to Rec. ITU-T H.262 | ISO/IEC 13818-2). This field is displayed for  $N \times \text{rep\_cntrl} / 2$  field duration. The other field of the picture is then displayed for  $N - N \times \text{rep\_cntrl} / 2$  field duration.

**freeze frame** – The value '010', in the `trick_mode_control` field. When this value is present it indicates a freeze frame video stream and defines the meaning of the following five bits in the PES packet header. The `field_id` field, defined in Table 2-25, identifies which field(s) should be displayed. The `field_id` field refers to the first video access unit that commences in the PES packet which contains the `field_id` field, unless the PES packet contains zero payload bytes. In the latter case the `field_id` field refers to the most recent previous video access unit.

**fast reverse** – The value '011', in the `trick_mode_control` field. When this value is present it indicates a fast reverse video stream and defines the meaning of the following five bits in the PES packet header. The `intra_slice_refresh` bit may be set to '1' indicating that there may be missing macroblocks which the decoder may replace with co-sited macroblocks of previously decoded pictures. The `field_id` field, defined in Table 2-25, indicates which field or fields should be displayed. The `frequency_truncation` field indicates that a restricted set of coefficients may be included. The meaning of the values of this field are shown in Table 2-26.

**slow reverse** – The value '100', in the `trick_mode_control` field. When this value is present it indicates a slow reverse video stream and defines the meaning of the following five bits in the PES packet header. In the case of ISO/IEC 11172-2 video and Rec. ITU-T H.262 | ISO/IEC 13818-2 video progressive sequences, the picture should be displayed for  $N \times \text{rep\_cntrl}$  picture duration, where  $N$  is defined above.

In the case of Rec. ITU-T H.262 | ISO/IEC 13818-2 interlaced sequences, the picture should be displayed for  $N \times \text{rep\_cntrl}$  field duration. If the picture is a frame picture, the first field to be displayed is the bottom field if `top_field_first` is 1, and the top field if `top_field_first` is '0' (refer to Rec. ITU-T H.262 | ISO/IEC 13818-2). This field is displayed for  $N \times \text{rep\_cntrl} / 2$  field duration. The other field of the picture is then displayed for  $N - N \times \text{rep\_cntrl} / 2$  field duration.

**field\_id** – A 2-bit field that indicates which field(s) should be displayed. It is coded according to Table 2-25.

**Table 2-25 – Field\_id field control values**

Value	Description
'00'	Display from top field only
'01'	Display from bottom field only
'10'	Display complete frame
'11'	Reserved

**intra\_slice\_refresh** – A 1-bit flag, which when set to '1', indicates that there may be missing macroblocks between coded slices of video data in this PES packet. When set to '0' this may not occur. For more information, see Rec. ITU-T H.262 | ISO/IEC 13818-2. The decoder may replace missing macroblocks with co-sited macroblocks of previously decoded pictures.

**frequency\_truncation** – A 2-bit field which indicates that a restricted set of coefficients may have been used in coding the video data in this PES packet. The values are defined in Table 2-26.

**Table 2-26 – Coefficient selection values**

Value	Description
'00'	Only DC coefficients are non-zero
'01'	Only the first three coefficients are non-zero
'10'	Only the first six coefficients are non-zero
'11'	All coefficients may be non-zero

**rep\_cntrl** – A 5-bit field that indicates the number of times each field in an interlaced picture should be displayed, or the number of times that a progressive picture should be displayed. It is a function of the `trick_mode_control` field and the `top_field_first` bit in the video sequence header whether the top field or the bottom field should be displayed first in the case of interlaced pictures. The value '0' is forbidden.

**additional\_copy\_info** – This 7-bit field contains private data relating to copyright information.

**previous\_PES\_packet\_CRC** – The `previous_PES_packet_CRC` is a 16-bit field that contains the CRC value that yields a zero output of the 16 registers in the decoder similar to the one defined in Annex A, but with the polynomial:

$$x^{16} + x^{12} + x^5 + 1$$

after processing the data bytes of the previous PES packet, exclusive of the PES packet header.

NOTE 5 – This CRC is intended for use in network maintenance such as isolating the source of intermittent errors. It is not intended for use by elementary stream decoders. It is calculated only over the data bytes because PES packet header data can be modified during transport.

**PES\_private\_data\_flag** – A 1-bit flag which when set to '1' indicates that the PES packet header contains private data. When set to a value of '0' it indicates that private data is not present in the PES header.

**pack\_header\_field\_flag** – A 1-bit flag which when set to '1' indicates that an ISO/IEC 11172-1 pack header or a program stream pack header is stored in this PES packet header. If this field is in a PES packet that is contained in a program stream, then this field shall be set to '0'. In a transport stream, when set to the value '0' it indicates that no pack header is present in the PES header.

**program\_packet\_sequence\_counter\_flag** – A 1-bit flag which when set to '1' indicates that the program\_packet\_sequence\_counter, MPEG1\_MPEG2\_identifier, and original\_stuff\_length fields are present in this PES packet. When set to a value of '0' it indicates that these fields are not present in the PES header.

**P-STD\_buffer\_flag** – A 1-bit flag which when set to '1' indicates that the P-STD\_buffer\_scale and P-STD\_buffer\_size are present in the PES packet header. When set to a value of '0' it indicates that these fields are not present in the PES header.

**PES\_extension\_flag\_2** – A 1-bit field which when set to '1' indicates the presence of the PES\_extension\_field\_length field and associated fields. When set to a value of '0' this indicates that the PES\_extension\_field\_length field and any associated fields are not present.

**PES\_private\_data** – This is a 16-byte field which contains private data. This data, combined with the fields before and after, shall not emulate the packet\_start\_code\_prefix (0x000001).

**pack\_field\_length** – This is an 8-bit field which indicates the length, in bytes, of the pack\_header\_field().

**program\_packet\_sequence\_counter** – The program\_packet\_sequence\_counter field is a 7-bit field. It is an optional counter that increments with each successive PES packet from a program stream or from an ISO/IEC 11172-1 stream or the PES packets associated with a single program definition in a transport stream, providing functionality similar to a continuity counter (refer to 2.4.3.2). This allows an application to retrieve the original PES packet sequence of a program stream or the original packet sequence of the original ISO/IEC 11172-1 stream. The counter will wrap around to 0 after its maximum value. Repetition of PES packets shall not occur. Consequently, no two consecutive PES packets in the program multiplex shall have identical program\_packet\_sequence\_counter values.

**MPEG1\_MPEG2\_identifier** – A 1-bit flag which when set to '1' indicates that this PES packet carries information from an ISO/IEC 11172-1 stream. When set to '0' it indicates that this PES packet carries information from a program stream.

**original\_stuff\_length** – This 6-bit field specifies the number of stuffing bytes used in the original Rec. ITU-T H.222.0 | ISO/IEC 13818-1 PES packet header or in the original ISO/IEC 11172-1 packet header.

**P-STD\_buffer\_scale** – The P-STD\_buffer\_scale is a 1-bit field, the meaning of which is only defined if this PES packet is contained in a program stream. It indicates the scaling factor used to interpret the subsequent P-STD\_buffer\_size field. If the preceding stream\_id indicates an audio stream, P-STD\_buffer\_scale shall have the value '0'. If the preceding stream\_id indicates a video stream, P-STD\_buffer\_scale shall have the value '1'. For all other stream types, the value may be either '1' or '0'.

**P-STD\_buffer\_size** – The P-STD\_buffer\_size is a 13-bit unsigned integer, the meaning of which is only defined if this PES packet is contained in a program stream. It defines the size of the input buffer,  $BS_n$ , in the P-STD. If P-STD\_buffer\_scale has the value '0', then the P-STD\_buffer\_size measures the buffer size in units of 128 bytes. If P-STD\_buffer\_scale has the value '1', then the P-STD\_buffer\_size measures the buffer size in units of 1024 bytes. Thus:

$$\text{if } (P - STD\_buffer\_scale == 0) \\ BS_n = \bar{P} - STD\_buffer\_size \times 128 \quad (2-16)$$

else:

$$BS_n = P - STD\_buffer\_size \times 1024 \quad (2-17)$$

The encoded value of the P-STD buffer size takes effect immediately when the P-STD\_buffer\_size field is received by the Rec. ITU-T H.222.0 | ISO/IEC 13818-1 System Target Decoder (refer to 2.7.7).

For AVC video streams conforming to one or more profiles defined in Annex A of Rec. ITU-T H.264 | ISO/IEC 14496-10, the size  $BS_n$  shall be larger than or equal to the size of the CPB signalled by the CpbSize[ cpb\_cnt\_minus1 ] specified by the NAL hrd\_parameters() in the AVC video stream. If the NAL hrd\_parameters() are not present in the AVC video stream, then  $BS_n$  shall be larger than or equal to the size of the NAL CPB for the byte stream format defined in Annex A of Rec. ITU-T H.264 | ISO/IEC 14496-10 as  $1200 \times \text{MaxCPB}$  for the applied level.

For video sub-bitstreams of AVC video streams conforming to one or more profiles defined in Annex G of Rec. ITU-T H.264 | ISO/IEC 14496-10, the size  $BS_n$  shall be larger than or equal to the size of the CPB signalled by the CpbSize[ cpb\_cnt\_minus1 ] specified by the NAL hrd\_parameters() for the video sub-bitstream carried in elementary stream  $ES_n$  as defined in 2.14.3.6. If the NAL hrd\_parameters() are not present in the video sub-bitstream, the size  $BS_n$  shall be larger than or equal to the size of the NAL CPB for the byte stream format defined in Rec. ITU-T H.264 | ISO/IEC 14496-10 as  $1200 \times \text{MaxCPB}$  for the applied level for the elementary stream  $ES_n$ .

For MVC video sub-bitstreams of AVC video streams conforming to one or more profiles defined in Annex H of Rec. ITU-T H.264 | ISO/IEC 14496-10, the size  $BS_n$  shall be larger than or equal to the size of the CPB signalled by the

CpbSize[ cpb\_cnt\_minus1 ] specified by the NAL hrd\_parameters() for the MVC video sub-bitstreams carried in elementary stream ES<sub>n</sub>, as defined in 2.14.3.6. If the NAL hrd\_parameters() are not present in the MVC video sub-bitstreams, the size BS<sub>n</sub> shall be larger than or equal to the size of the NAL CPB for the byte stream format defined in Rec. ITU-T H.264 | ISO/IEC 14496-10 as 1200 × MaxCPB for the applied level for the elementary stream ES<sub>n</sub>.

**PES\_extension\_field\_length** – This is a 7-bit field which specifies the length, in bytes, of the data following this field in the PES extension field up to and including any reserved bytes.

**stream\_id\_extension\_flag** – A 1-bit flag, which when set to '0' indicates that a stream\_id\_extension field is present in the PES packet header. The value of '1' for this flag is reserved.

**stream\_id\_extension** – In program streams, the stream\_id\_extension specifies the type and number of the elementary stream as defined by the stream\_id\_extension in Table 2-27. In transport streams, the stream\_id\_extension may be set to any valid value which correctly describes the elementary stream type as defined in Table 2-27. In transport streams, the elementary stream type is specified in the program-specific information as specified in 2.4.4. Note that this field is used as an extension of the stream\_id defined above. This field shall not be used unless the value of stream\_id is '11111101'.

**Table 2-27 – Stream\_id\_extension assignments**

stream_id_extension	Note	stream coding
'000 0000'	1	IPMP control information stream
'000 0001'	2	IPMP stream
'000 0010' .. '000 1111'		ISO/IEC 14496-17 text stream
'001 0000' .. '001 1111'		ISO/IEC 23002-3 auxiliary video stream
'010 0000' .. '011 1111'		reserved_data_stream
'100 0000' .. '111 1111'		private_stream

NOTE 1 – PES packets of stream\_id\_extension 0b000 0000 (IPMP control information stream) have a unique syntax specified in ISO/IEC 13818-11 (MPEG-2 IPMP).

NOTE 2 – PES packets of stream\_id\_extension 0b000 0001 (IPMP stream) have a unique syntax specified in ISO/IEC 13818-11 (MPEG-2 IPMP).

**stuffing\_byte** – This is a fixed 8-bit value equal to '1111 1111' that can be inserted by the encoder, for example to meet the requirements of the channel. It is discarded by the decoder. No more than 32 stuffing bytes shall be present in one PES packet header.

**PES\_packet\_data\_byte** – PES\_packet\_data\_bytes shall be contiguous bytes of data from the elementary stream indicated by the packet's stream\_id or PID. When the elementary stream data conforms to Rec. ITU-T H.262 | ISO/IEC 13818-2 or ISO/IEC 13818-3, the PES\_packet\_data\_bytes shall be byte aligned to the bytes of this Recommendation | International Standard. The byte-order of the elementary stream shall be preserved. The number of PES\_packet\_data\_bytes, N, is specified by the PES\_packet\_length field. N shall be equal to the value indicated in the PES\_packet\_length minus the number of bytes between the last byte of the PES\_packet\_length field and the first PES\_packet\_data\_byte.

In the case of a private\_stream\_1, private\_stream\_2, ECM\_stream, or EMM\_stream, the contents of the PES\_packet\_data\_byte field are user definable and will not be specified by ITU-T | ISO/IEC in the future.

**padding\_byte** – This is a fixed 8-bit value equal to '1111 1111'. It is discarded by the decoder.

**tref\_extension\_flag** – A 1-bit flag, which when set to '0' indicates that a TREF field is present in the PES packet header. The value of '1' for this flag is reserved.

**TREF (timestamp reference)** – The TREF is a 33-bit number coded in three separate fields. It indicates the decoding time value,  $td_r(j)$ , in the system target decoder as indicated by the DTS, or in absence of the DTS, by the PTS of the PES header of the same  $j$ -th access unit in a corresponding elementary stream  $n$ .

#### 2.4.3.8 Carriage of program streams and ISO/IEC 11172-1 Systems streams in the transport stream

The transport stream contains optional fields to support the carriage of program streams and ISO/IEC 11172-1 Systems streams, in a way that allows simple reconstruction of the respective stream at the decoder.

When placing a program stream into a transport stream, program stream PES packets with stream\_id values of private\_stream\_1, Rec. ITU-T H.262 | ISO/IEC 13818-2 or ISO/IEC 11172-2 video, and ISO/IEC 13818-3 or ISO/IEC 11172-3 audio, are carried in transport stream packets.

For these PES packets, when reconstructing the program stream at the transport stream decoder, the PES packet data is copied to the program stream being reconstructed.

For program streams PES packets with stream\_id values of program\_stream\_map, padding\_stream, private\_stream\_2, ECM, EMM, DSM\_CC\_stream, or program\_stream\_directory, all the bytes of the program stream PES packet, except for the packet\_start\_code\_prefix, are placed into the data\_bytes fields of a new PES packet. The stream\_id of this new PES packet has the value of ancillary\_stream (refer to Table 2-22). This new PES packet is then carried in transport stream packets.

When reconstructing the program stream at the transport stream decoder, for PES packets with a stream\_id value of ancillary\_stream\_id, packet\_start\_code\_prefix is written to the program stream being reconstructed, followed by the data\_byte fields from these transport stream PES packets.

ISO/IEC 11172-1 streams are carried within transport streams by first replacing ISO/IEC 11172-1 packet headers with Rec. ITU-T H.262 | ISO/IEC 13818-2 PES packet headers. ISO/IEC 11172-1 packet header field values are copied to the equivalent Rec. ITU-T H.262 | ISO/IEC 13818-2 PES packet header fields.

The program\_packet\_sequence\_counter field is included within the header of each PES packet carrying data from a program stream, or an ISO/IEC 11172-1 System stream. This allows the order of PES packets in the original program stream, or packets in the original ISO/IEC 11172-1 system stream, to be reproduced at the decoder.

The pack\_header() field of a program stream, or an ISO/IEC 11172-1 system stream, is carried in the transport stream in the header of the immediately following PES packet.

**2.4.4 Program-specific information**

**2.4.4.1 General**

Program-specific information (PSI) includes both Rec. ITU-T H.222.0 | ISO/IEC 13818-1 normative data and private data that enable demultiplexing of programs by decoders. Programs are composed of one or more elementary streams, each labelled with a PID. Programs, elementary streams or parts thereof may be scrambled for conditional access. However, program-specific information shall not be scrambled.

In transport streams, program-specific information is classified into six table structures as shown in Table 2-28. While these structures may be thought of as simple tables, they shall be segmented into sections and inserted in transport stream packets, some with predetermined PIDs and others with user selectable PIDs.

**Table 2-28 – Program-specific information**

Structure Name	Stream Type	Reserved PID #	Description
Program association table	Rec. ITU-T H.222.0   ISO/IEC 13818-1	0x00	Associates program number and program map table PID
Program map table	Rec. ITU-T H.222.0   ISO/IEC 13818-1	Assigned in the PAT	Specifies PID values for components of one or more programs
Network information table	Private	Assigned in the PAT	Physical network parameters such as FDM frequencies, transponder numbers, etc.
Conditional access table	Rec. ITU-T H.222.0   ISO/IEC 13818-1	0x01	Associates one or more (private) EMM streams each with a unique PID value
Transport stream description table	Rec. ITU-T H.222.0   ISO/IEC 13818-1	0x02	Associates one or more descriptors from Table 2-45 to an entire transport stream
IPMP control information table	Rec. ITU-T H.222.0   ISO/IEC 13818-1	0x03	Contains IPMP tool list, rights container, tool container defined in ISO/IEC 13818-11

Rec. ITU-T H.222.0 | ISO/IEC 13818-1 defined PSI tables shall be segmented into one or more sections that are carried within transports packets. A section is a syntactic structure that shall be used for mapping each Rec. ITU-T H.222.0 | ISO/IEC 13818-1 defined PSI table into transport stream packets.

Along with Rec. ITU-T H.222.0 | ISO/IEC 13818-1 defined PSI tables, it is possible to carry private data tables. The means by which private information is carried within transport stream packets is not defined by this Specification. It may be structured in the same manner used for carrying of Rec. ITU-T H.222.0 | ISO/IEC 13818-1 defined PSI tables, such that the syntax for mapping this private data is identical to that used for the mapping of Rec. ITU-T H.222.0 | ISO/IEC 13818-1 defined PSI tables. For this purpose, a private section is defined. If the private data is carried in transport stream packets with the same PID value as transport stream packets carrying program map tables (as identified in the program association table), then the private\_section syntax and semantics shall be used. The data carried in the private\_data\_bytes may be scrambled. However, no other fields of the private\_section shall be scrambled. This private\_section allows data to be transmitted with a minimum of structure. When this structure is not used, the mapping of private data within transport stream packets is not defined by this Recommendation | International Standard.

Sections may be variable in length. The beginning of a section is indicated by a pointer\_field in the transport stream packet payload. The syntax of this field is specified in Table 2-29.

Adaptation fields may occur in transport stream packets carrying transport stream sections.

Within a transport stream, packet stuffing bytes of value 0xFF may be found in the payload of transport stream packets carrying sections only after the last byte of a section. In this case all bytes until the end of the transport stream packet shall also be stuffing bytes of value 0xFF. These bytes may be discarded by a decoder. In such a case, the payload of the next transport stream packet with the same PID value shall begin with a pointer\_field of value 0x00 indicating that the next section starts immediately thereafter.

Each transport stream shall contain one or more transport stream packets with PID value 0x0000. These transport stream packets together shall contain a complete program association table, providing a complete list of all programs within the transport stream. The most recently transmitted version of the table with the current\_next\_indicator set to a value of '1' shall always apply to the current data in the transport stream. Any changes in the programs carried within the transport stream shall be described in an updated version of the program association table carried in transport stream packets with PID value 0x0000. These sections shall all use table\_id value 0x00. Only sections with this value of table\_id are permitted within transport stream packets with PID value of 0x0000. For a new version of the PAT to become valid, all sections (as indicated in the last\_section\_number) with a new version\_number and with the current\_next\_indicator set to '1' must exit B<sub>sys</sub> defined in the T-STD (refer to 2.4.2.1). The PAT becomes valid when the last byte of the section needed to complete the table exits B<sub>sys</sub>.

Whenever one or more elementary streams within a transport stream are scrambled, transport stream packets with a PID value 0x0001 shall be transmitted containing a complete conditional access table including CA\_descriptors associated with the scrambled streams. The transmitted transport stream packets will together form one complete version of the conditional access table. The most recently transmitted version of the table with the current\_next\_indicator set to a value of '1' shall always apply to the current data in the transport stream. Any changes in scrambling making the existing table invalid or incomplete shall be described in an updated version of the conditional access table. These sections will all use table\_id value 0x01. Only sections with this table\_id value are permitted within transport stream packets with a PID value of 0x0001. For a new version of the CAT to become valid, all sections (as indicated in the last\_section\_number) with a new version\_number and with the current\_next\_indicator set to '1' must exit B<sub>sys</sub>. The CAT becomes valid when the last byte of the section needed to complete the table exits B<sub>sys</sub>.

Each transport stream shall contain one or more transport stream packets with PID values which are labelled under the program association table as transport stream packets containing TS program map sections. Each program listed in the program association table shall be described in a unique TS\_program\_map\_section. Every program shall be fully defined within the transport stream itself. Private data which has an associated elementary\_PID field in the appropriate program map table section is part of the program. Other private data may exist in the transport stream without being listed in the program map table section. The most recently transmitted version of the TS\_program\_map\_section with the current\_next\_indicator set to a value of '1' shall always apply to the current data within the transport stream. Any changes in the definition of any of the programs carried within the transport stream shall be described in an updated version of the corresponding section of the program map table carried in transport stream packets with the PID value identified as the program\_map\_PID for that specific program. All transport stream packets which carry a given TS\_program\_map\_section shall have the same PID value. During the continuous existence of a program, including all of its associated events, the program\_map\_PID shall not change. A program definition shall not span more than one TS\_program\_map\_section. A new version of a TS\_program\_map\_section becomes valid when the last byte of that section with a new version\_number and with the current\_next\_indicator set to '1' exits B<sub>sys</sub>.

Sections with a table\_id value of 0x02 shall contain program map table information. Such sections may be carried in transport stream packets with different PID values.

The network information table is optional, and its contents are private. If present it is carried within transport stream packets that will have the same PID value, called the network\_PID. The network\_PID value is defined by the user and, when present, shall be found in the program association table under the reserved program\_number 0x0000. If the network information table exists, it shall take the form of one or more private\_sections.

The maximum number of bytes in a section of a Rec. ITU-T H.222.0 | ISO/IEC 13818-1 defined PSI table is 1024 bytes. The maximum number of bytes in a private\_section is 4096 bytes.

The transport stream description table is optional. When present, the transport stream description is carried within transport stream packets that have a PID value 0x0002 as specified in Table 2-28 and shall apply to the entire transport stream. Sections of the transport stream description shall use a table\_id value of 0x03 as specified in Table 2-31 and its contents are restricted to descriptors specified in Table 2-45. The TS\_description\_section becomes valid when the last byte of the section required to complete the table exits B<sub>sys</sub>.

There are no restrictions on the occurrence of start codes, sync bytes or other bit patterns in transport stream section data.

2.4.4.2 Pointer

The pointer\_field syntax is defined in Table 2-29.

Table 2-29 – Program-specific information pointer

Syntax	No. of bits	Mnemonic
pointer_field	8	uimsbf

2.4.4.3 Semantics definition of fields in pointer syntax

**pointer\_field** – This is an 8-bit field whose value shall be the number of bytes, immediately following the pointer\_field until the first byte of the first section that is present in the payload of the transport stream packet (so a value of 0x00 in the pointer\_field indicates that the section starts immediately after the pointer\_field). When at least one section begins in a given transport stream packet, then the payload\_unit\_start\_indicator (refer to 2.4.3.2) shall be set to '1' and the first byte of the payload of that transport stream packet shall contain the pointer. When no section begins in a given transport stream packet, then the payload\_unit\_start\_indicator shall be set to '0' and no pointer shall be sent in the payload of that packet.

2.4.4.4 Program association table

The program association table (PAT) provides the correspondence between a program\_number and the PID value of the transport stream packets which carry the program definition. The program\_number is the numeric label associated with a program.

The overall table is contained in one or more sections with the following syntax. It may be segmented to occupy multiple sections (see Table 2-30).

Table 2-30 – Program association section

Syntax	No. of bits	Mnemonic
program_association_section() {		
<b>table_id</b>	8	uimsbf
<b>section_syntax_indicator</b>	1	bslbf
'0'	1	bslbf
<b>reserved</b>	2	bslbf
<b>section_length</b>	12	uimsbf
<b>transport_stream_id</b>	16	uimsbf
<b>reserved</b>	2	bslbf
<b>version_number</b>	5	uimsbf
<b>current_next_indicator</b>	1	bslbf
<b>section_number</b>	8	uimsbf
<b>last_section_number</b>	8	uimsbf
for (i = 0; i < N; i++) {		
<b>program_number</b>	16	uimsbf
<b>reserved</b>	3	bslbf
if (program_number == '0') {		
<b>network_PID</b>	13	uimsbf
}		
else {		
<b>program_map_PID</b>	13	uimsbf
}		
}		
<b>CRC_32</b>	32	rpchof
}		

#### 2.4.4.5 Table\_id assignments

The table\_id field identifies the contents of a transport stream section as shown in Table 2-31.

**Table 2-31 – table\_id assignment values**

Value	Description
0x00	program_association_section
0x01	conditional_access_section (CA_section)
0x02	TS_program_map_section
0x03	TS_description_section
0x04	ISO_IEC_14496_scene_description_section
0x05	ISO_IEC_14496_object_descriptor_section
0x06	Metadata_section
0x07	IPMP Control Information Section (defined in ISO/IEC 13818-11)
0x08	ISO_IEC_14496_section
0x09	ISO/IEC 23001-11 (Green access unit) section
0x0A	ISO/IEC 23001-10 (Quality access unit) section
0x0B	ISO/IEC 23001-13 (Media Orchestration access unit) section
0x0C .. 0x37	Rec. ITU-T H.222.0   ISO/IEC 13818-1 reserved
0x38 .. 0x3F	Defined in ISO/IEC 13818-6
0x40 .. 0xFE	User private
0xFF	Forbidden

#### 2.4.4.6 Semantic definition of fields in program association section

**table\_id** – This is an 8-bit field, which shall be set to 0x00 as shown in Table 2-31.

**section\_syntax\_indicator** – The section\_syntax\_indicator is a 1-bit field which shall be set to '1'.

**section\_length** – This is a 12-bit field, the first two bits of which shall be '00'. The remaining 10 bits specify the number of bytes of the section, starting immediately following the section\_length field, and including the CRC. The value in this field shall not exceed 1021 (0x3FD).

**transport\_stream\_id** – This is a 16-bit field which serves as a label to identify this transport stream from any other multiplex within a network. Its value is defined by the user.

**version\_number** – This 5-bit field is the version number of the whole program association table. The version number shall be incremented by 1 modulo 32 whenever the definition of the program association table changes. When the current\_next\_indicator is set to '1', then the version\_number shall be that of the currently applicable program association table. When the current\_next\_indicator is set to '0', then the version\_number shall be that of the next applicable program association table.

**current\_next\_indicator** – A 1-bit indicator, which when set to '1' indicates that the program association table sent is currently applicable. When the bit is set to '0', it indicates that the table sent is not yet applicable and shall be the next table to become valid.

**section\_number** – This 8-bit field gives the number of this section. The section\_number of the first section in the Program Association Table shall be 0x00. It shall be incremented by 1 with each additional section in the program association table.

**last\_section\_number** – This 8-bit field specifies the number of the last section (that is, the section with the highest section\_number) of the complete program association table.

**program\_number** – Program\_number is a 16-bit field. It specifies the program to which the program\_map\_PID is applicable. When set to 0x0000, then the following PID reference shall be the network PID. For all other cases the value of this field is user defined. This field shall not take any single value more than once within one version of the program association table.

NOTE – The program\_number may be used as a designation for a broadcast channel, for example.

**network\_PID** – The network\_PID is a 13-bit field, which is used only in conjunction with the value of the program\_number set to 0x0000, specifies the PID of the transport stream packets which shall contain the network

information table. The value of the network\_PID field is defined by the user, but shall only take values as specified in Table 2-3. The presence of the network\_PID is optional.

**program\_map\_PID** – The program\_map\_PID is a 13-bit field specifying the PID of the transport stream packets which shall contain the program\_map\_section applicable for the program as specified by the program\_number. No program\_number shall have more than one program\_map\_PID assignment. The value of the program\_map\_PID is defined by the user, but shall only take values as specified in Table 2-3.

**CRC\_32** – This is a 32-bit field that contains the CRC value that gives a zero output of the registers in the decoder defined in Annex A after processing the entire program association section.

**2.4.4.7 Conditional access table**

The conditional access table (CAT) provides the association between one or more conditional access (CA) systems, their EMM streams and any special parameters associated with them. Refer to 2.6.16 for a definition of the descriptor() field in Table 2-32.

The table is contained in one or more sections with the following syntax. It may be segmented to occupy multiple sections.

**Table 2-32 – Conditional access section**

Syntax	No. of bits	Mnemonic
CA_section() {		
<b>table_id</b>	<b>8</b>	<b>uimsbf</b>
<b>section_syntax_indicator</b>	<b>1</b>	<b>bslbf</b>
'0'	<b>1</b>	<b>bslbf</b>
reserved	<b>2</b>	<b>bslbf</b>
<b>section_length</b>	<b>12</b>	<b>uimsbf</b>
reserved	<b>18</b>	<b>bslbf</b>
<b>version_number</b>	<b>5</b>	<b>uimsbf</b>
<b>current_next_indicator</b>	<b>1</b>	<b>bslbf</b>
<b>section_number</b>	<b>8</b>	<b>uimsbf</b>
<b>last_section_number</b>	<b>8</b>	<b>uimsbf</b>
for (i = 0; i < N; i++) {		
descriptor()		
}		
<b>CRC_32</b>	<b>32</b>	<b>rpchof</b>
}		

**2.4.4.8 Semantic definition of fields in conditional access section**

**table\_id** – This is an 8-bit field, which shall be set to 0x01 as specified in Table 2-31.

**section\_syntax\_indicator** – The section\_syntax\_indicator is a 1-bit field which shall be set to '1'.

**section\_length** – This is a 12-bit field, the first two bits of which shall be '00'. The remaining 10-bits specify the number of bytes of the section starting immediately following the section\_length field, and including the CRC. The value in this field shall not exceed 1021 (0x3FD).

**version\_number** – This 5-bit field is the version number of the entire conditional access table. The version number shall be incremented by 1 modulo 32 when a change in the information carried within the CA table occurs. When the current\_next\_indicator is set to '1', then the version\_number shall be that of the currently applicable conditional access table. When the current\_next\_indicator is set to '0', then the version\_number shall be that of the next applicable conditional access table.

**current\_next\_indicator** – A 1-bit indicator, which when set to '1' indicates that the conditional access table sent is currently applicable. When the bit is set to '0', it indicates that the conditional access table sent is not yet applicable and shall be the next conditional access table to become valid.

**section\_number** – This 8-bit field gives the number of this section. The section\_number of the first section in the conditional access table shall be 0x00. It shall be incremented by 1 with each additional section in the conditional access table.

**last\_section\_number** – This 8-bit field specifies the number of the last section (that is, the section with the highest section\_number) of the conditional access table.

**CRC\_32** – This is a 32-bit field that contains the CRC value that gives a zero output of the registers in the decoder defined in Annex A after processing the entire conditional access section.

#### 2.4.4.9 Program map table

The program map table provides the mappings between program numbers and the program elements that comprise them. A single instance of such a mapping is referred to as a "program definition". The program map table is the complete collection of all program definitions for a transport stream. This table shall be transmitted in packets, the PID values of which are selected by the encoder. More than one PID value may be used, if desired. The table is contained in one or more sections with the following syntax. It may be segmented to occupy multiple sections. In each section, the section number field shall be set to zero. Sections are identified by the program\_number field.

Definition for the descriptor() fields may be found in 2.6 (see Table 2-33).

**Table 2-33 – Transport stream program map section**

Syntax	No. of bits	Mnemonic
TS_program_map_section() {		
<b>table_id</b>	8	uimsbf
<b>section_syntax_indicator</b>	1	bslbf
'0'	1	bslbf
<b>reserved</b>	2	bslbf
<b>section_length</b>	12	uimsbf
<b>program_number</b>	16	uimsbf
<b>reserved</b>	2	bslbf
<b>version_number</b>	5	uimsbf
<b>current_next_indicator</b>	1	bslbf
<b>section_number</b>	8	uimsbf
<b>last_section_number</b>	8	uimsbf
<b>reserved</b>	3	bslbf
<b>PCR_PID</b>	13	uimsbf
<b>reserved</b>	4	bslbf
<b>program_info_length</b>	12	uimsbf
for (i = 0; i < N; i++) {		
descriptor()		
}		
for (i = 0; i < N1; i++) {		
<b>stream_type</b>	8	uimsbf
<b>reserved</b>	3	bslbf
<b>elementary_PID</b>	13	uimsbf
<b>reserved</b>	4	bslbf
<b>ES_info_length</b>	12	uimsbf
for (i = 0; i < N2; i++) {		
descriptor()		
}		
}		
<b>CRC_32</b>	32	rpchof
}		

#### 2.4.4.10 Semantic definition of fields in transport stream program map section

**table\_id** – This is an 8-bit field, which in the case of a TS\_program\_map\_section shall be always set to 0x02 as shown in Table 2-31.

**section\_syntax\_indicator** – The section\_syntax\_indicator is a 1-bit field which shall be set to '1'.

**section\_length** – This is a 12-bit field, the first two bits of which shall be '00'. The remaining 10 bits specify the number of bytes of the section starting immediately following the section\_length field, and including the CRC. The value in this field shall not exceed 1021 (0x3FD).

**program\_number** – program\_number is a 16-bit field. It specifies the program to which the program\_map\_PID is applicable. One program definition shall be carried within only one TS\_program\_map\_section. This implies that a program definition is never longer than 1016 (0x3F8). See Informative Annex C for ways to deal with the cases when that length is not sufficient. The program\_number may be used as a designation for a broadcast channel, for example. By describing the different program elements belonging to a program, data from different sources (e.g., sequential events) can be concatenated together to form a continuous set of streams using a program\_number. For examples of applications refer to Annex C.

**version\_number** – This 5-bit field is the version number of the TS\_program\_map\_section. The version number shall be incremented by 1 modulo 32 when a change in the information carried within the section occurs. Version number refers to the definition of a single program, and therefore to a single section. When the current\_next\_indicator is set to '1', then the version\_number shall be that of the currently applicable TS\_program\_map\_section. When the current\_next\_indicator is set to '0', then the version\_number shall be that of the next applicable TS\_program\_map\_section.

**current\_next\_indicator** – A 1-bit field, which when set to '1' indicates that the TS\_program\_map\_section sent is currently applicable. When the bit is set to '0', it indicates that the TS\_program\_map\_section sent is not yet applicable and shall be the next TS\_program\_map\_section to become valid.

**section\_number** – The value of this 8-bit field shall be 0x00.

**last\_section\_number** – The value of this 8-bit field shall be 0x00.

**PCR\_PID** – This is a 13-bit field indicating the PID of the transport stream packets which shall contain the PCR fields valid for the program specified by program\_number. If no PCR is associated with a program definition for private streams, then this field shall take the value of 0x1FFF. Refer to the semantic definition of PCR in 2.4.3.5 and Table 2-3 for restrictions on the choice of PCR\_PID value.

**program\_info\_length** – This is a 12-bit field, the first two bits of which shall be '00'. The remaining 10 bits specify the number of bytes of the descriptors immediately following the program\_info\_length field.

**stream\_type** – This is an 8-bit field specifying the type of program element carried within the packets with the PID whose value is specified by the elementary\_PID. The values of stream\_type are specified in Table 2-34.

NOTE – A Rec. ITU-T H.222.0 | ISO/IEC 13818-1 auxiliary stream is available for data types defined by this Specification, other than audio, video, and DSM-CC, such as the program stream directory and the program stream map.

Table 2-34 – Stream type assignments

Value	Description
0x00	ITU-T   ISO/IEC Reserved
0x01	ISO/IEC 11172-2 Video
0x02	Rec. ITU-T H.262   ISO/IEC 13818-2 Video or ISO/IEC 11172-2 constrained parameter video stream (see Note 2)
0x03	ISO/IEC 11172-3 Audio
0x04	ISO/IEC 13818-3 Audio
0x05	Rec. ITU-T H.222.0   ISO/IEC 13818-1 private_sections
0x06	Rec. ITU-T H.222.0   ISO/IEC 13818-1 PES packets containing private data
0x07	ISO/IEC 13522 MHEG
0x08	Rec. ITU-T H.222.0   ISO/IEC 13818-1 Annex A DSM-CC
0x09	Rec. ITU-T H.222.1
0x0A	ISO/IEC 13818-6 type A
0x0B	ISO/IEC 13818-6 type B
0x0C	ISO/IEC 13818-6 type C
0x0D	ISO/IEC 13818-6 type D
0x0E	Rec. ITU-T H.222.0   ISO/IEC 13818-1 auxiliary
0x0F	ISO/IEC 13818-7 Audio with ADTS transport syntax
0x10	ISO/IEC 14496-2 Visual
0x11	ISO/IEC 14496-3 Audio with the LATM transport syntax as defined in ISO/IEC 14496-3

Table 2-34 – Stream type assignments

Value	Description
0x12	ISO/IEC 14496-1 SL-packetized stream or M4Mux stream carried in PES packets
0x13	ISO/IEC 14496-1 SL-packetized stream or M4Mux stream carried in ISO/IEC 14496_sections
0x14	ISO/IEC 13818-6 Synchronized Download Protocol
0x15	Metadata carried in PES packets
0x16	Metadata carried in metadata_sections
0x17	Metadata carried in ISO/IEC 13818-6 Data Carousel
0x18	Metadata carried in ISO/IEC 13818-6 Object Carousel
0x19	Metadata carried in ISO/IEC 13818-6 Synchronized Download Protocol
0x1A	IPMP stream (defined in ISO/IEC 13818-11, MPEG-2 IPMP)
0x1B	AVC video stream conforming to one or more profiles defined in Annex A of Rec. ITU-T H.264   ISO/IEC 14496-10 or AVC video sub-bitstream of SVC as defined in 2.1.10 or MVC base view sub-bitstream, as defined in 2.1.103, or AVC video sub-bitstream of MVC, as defined in 2.1.8 or MVCD base view sub-bitstream, as defined in 2.1.108, or AVC video sub-bitstream of MVCD, as defined in 2.1.9, or AVC base layer of an HEVC video stream conforming to one or more profiles defined in Annex G or Annex H of Rec. ITU-T H.265   ISO/IEC 23008-2
0x1C	ISO/IEC 14496-3 Audio, without using any additional transport syntax, such as DST, ALS and SLS
0x1D	ISO/IEC 14496-17 Text
0x1E	Auxiliary video stream as defined in ISO/IEC 23002-3
0x1F	SVC video sub-bitstream of an AVC video stream conforming to one or more profiles defined in Annex G of Rec. ITU-T H.264   ISO/IEC 14496-10
0x20	MVC video sub-bitstream of an AVC video stream conforming to one or more profiles defined in Annex H of Rec. ITU-T H.264   ISO/IEC 14496-10
0x21	Video stream conforming to one or more profiles as defined in Rec. ITU-T T.800   ISO/IEC 15444-1
0x22	Additional view Rec. ITU-T H.262   ISO/IEC 13818-2 video stream for service-compatible stereoscopic 3D services (see Notes 3 and 4)
0x23	Additional view Rec. ITU-T H.264   ISO/IEC 14496-10 video stream conforming to one or more profiles defined in Annex A for service-compatible stereoscopic 3D services (see Notes 3 and 4)
0x24	Rec. ITU-T H.265   ISO/IEC 23008-2 video stream or an HEVC temporal video sub-bitstream (see Note 5)
0x25	HEVC temporal video subset of an HEVC video stream conforming to one or more profiles defined in Annex A of Rec. ITU-T H.265   ISO/IEC 23008-2
0x26	MVCD video sub-bitstream of an AVC video stream conforming to one or more profiles defined in Annex I of Rec. ITU-T H.264   ISO/IEC 14496-10
0x27	Timeline and External Media Information Stream (see Annex U)
0x28	HEVC enhancement sub-partition which includes TemporalId 0 of an HEVC video stream where all NALs units contained in the stream conform to one or more profiles defined in Annex G of Rec. ITU-T H.265   ISO/IEC 23008-2
0x29	HEVC temporal enhancement sub-partition of an HEVC video stream where all NAL units contained in the stream conform to one or more profiles defined in Annex G of Rec. ITU-T H.265   ISO/IEC 23008-2
0x2A	HEVC enhancement sub-partition which includes TemporalId 0 of an HEVC video stream where all NAL units contained in the stream conform to one or more profiles defined in Annex H of Rec. ITU-T H.265   ISO/IEC 23008-2
0x2B	HEVC temporal enhancement sub-partition of an HEVC video stream where all NAL units contained in the stream conform to one or more profiles defined in Annex H of Rec. ITU-T H.265   ISO/IEC 23008-2
0x2C	Green access units carried in MPEG-2 sections
0x2D	ISO/IEC 23008-3 Audio with MHAS transport syntax – main stream
0x2E	ISO/IEC 23008-3 Audio with MHAS transport syntax – auxiliary stream
0x2F	Quality access units carried in sections
0x30	Media Orchestration Access Units carried in sections
0x31	Substream of a Rec. ITU-T H.265   ISO/IEC 23008-2 video stream that contains a Motion Constrained Tile Set, parameter sets, slice headers or a combination thereof. See 2.17.5.1.
0x32	JPEG XS video stream conforming to one or more profiles as defined in ISO/IEC 21122-2

Table 2-34 – Stream type assignments

Value	Description
0x33	VVC video stream or a VVC temporal video sub-bitstream conforming to one or more profiles defined in Annex A of Rec. ITU-T H.266   ISO/IEC 23090-3
0x34	VVC temporal video subset of a VVC video stream conforming to one or more profiles defined in Annex A of Rec. ITU-T H.266   ISO/IEC 23090-3
0x35	EVC video stream or an EVC temporal video sub-bitstream conforming to one or more profiles defined in ISO/IEC 23094-1
0x36	LCEVC video stream conforming to one or more profiles defined in ISO/IEC 23094-2
0x37 .. 0x7E	Rec. ITU-T H.222.0   ISO/IEC 13818-1 reserved
0x7F	IPMP stream
0x80 .. 0xFF	User Private

NOTE 1 – In the above table various stream types are assigned for carriage of audio signals, with or without a transport syntax. Typically, the transport syntax is used for providing sync words. The use of a specific transport syntax, if at all, is specified in the clauses in this Specification specifying the transport of the various audio signals.

NOTE 2 – Rec. ITU-T H.262 | ISO/IEC 13818-2 video with frame packing arrangement information is signalled using stream\_type value 0x02.

NOTE 3 – The base view of service-compatible stereoscopic 3D services is signalled using stream\_type value 0x02 for Rec. ITU-T H.262 | ISO/IEC 13818-2 video or stream\_type 0x1B for Rec. ITU-T H.264 | ISO/IEC 14496-10 video.

NOTE 4 – The additional view for service-compatible stereoscopic 3D services is signalled using stream\_type value 0x22 for Rec. ITU-T H.262 | ISO/IEC 13818-2 video or stream\_type value 0x23 for Rec. ITU-T H.264 | ISO/IEC 14496-10 video conforming to one or more profiles defined in Annex A. For service-compatible stereoscopic 3D services, the additional view is not signalled using stream\_type values 0x02 or 0x1B.

NOTE 5 – In the case of a single ES carrying multiple HEVC tile substreams that are identified through adaptation field descriptors, stream type 0x24 can be used if the ES is deemed to be a backward compatible HEVC stream and is decodable on a legacy device.

**elementary\_PID** – This is a 13-bit field specifying the PID of the transport stream packets which carry the associated program element.

**ES\_info\_length** – This is a 12-bit field, the first two bits of which shall be '00'. The remaining 10 bits specify the number of bytes of the descriptors of the associated program element immediately following the ES\_info\_length field.

**CRC\_32** – This is a 32-bit field that contains the CRC value that gives a zero output of the registers in the decoder defined in Annex B after processing the entire transport stream program map section.

**2.4.4.11 Syntax of the private section**

When private data is sent in transport stream packets with a PID value designated as a program map PID in the program association table the private\_section shall be used. The private\_section allows data to be transmitted with a minimum of structure while enabling a decoder to parse the stream. The sections may be used in two ways: if the section\_syntax\_indicator is set to '1', then the whole structure common to all tables shall be used; if the indicator is set to '0', then only the fields 'table\_id' through 'private\_section\_length' shall follow the common structure syntax and semantics and the rest of the private\_section may take any form the user determines. Examples of extended use of this syntax are found in informative Annex C.

A private table may be made of several private\_sections, all with the same table\_id (see Table 2-35).

Table 2-35 – Private section

Syntax	No. of bits	Mnemonic
private_section() {		
<b>table_id</b>	8	<b>uimsbf</b>
<b>section_syntax_indicator</b>	1	<b>bslbf</b>
<b>private_indicator</b>	1	<b>bslbf</b>
<b>reserved</b>	2	<b>bslbf</b>
<b>private_section_length</b>	12	<b>uimsbf</b>
if (section_syntax_indicator == '0') {		
for (i = 0; i < N; i++) {		
<b>private_data_byte</b>	8	<b>bslbf</b>
}		
}		
else {		
<b>table_id_extension</b>	16	<b>uimsbf</b>
<b>reserved</b>	2	<b>bslbf</b>
<b>version_number</b>	5	<b>uimsbf</b>
<b>current_next_indicator</b>	1	<b>bslbf</b>
<b>section_number</b>	8	<b>uimsbf</b>
<b>last_section_number</b>	8	<b>uimsbf</b>
for (i = 0; i < private_section_length-9; i++) {		
<b>private_data_byte</b>	8	<b>bslbf</b>
}		
<b>CRC_32</b>	32	<b>rpchof</b>
}		
}		

#### 2.4.4.12 Semantic definition of fields in private section

**table\_id** – This 8-bit field, the value of which identifies the Private Table this section belongs to. Only values defined in Table 2-31 as "user private" may be used.

**section\_syntax\_indicator** – This is a 1-bit indicator. When set to '1', it indicates that the private section follows the generic section syntax beyond the private\_section\_length field. When set to '0', it indicates that the private\_data\_bytes immediately follow the private\_section\_length field.

**private\_indicator** – This is a 1-bit user-definable flag that shall not be specified by ITU-T | ISO/IEC in the future.

**private\_section\_length** – A 12-bit field. It specifies the number of remaining bytes in the private section immediately following the private\_section\_length field up to the end of the private\_section. The value in this field shall not exceed 4093 (0xFFD).

**private\_data\_byte** – The private\_data\_byte field is user definable and shall not be specified by ITU-T | ISO/IEC in the future.

**table\_id\_extension** – This is a 16-bit field. Its use and value are defined by the user.

**version\_number** – This 5-bit field is the version number of the private\_section. The version\_number shall be incremented by 1 modulo 32 when a change in the information carried within the private\_section occurs. When the current\_next\_indicator is set to '0', then the version\_number shall be that of the next applicable private\_section with the same table\_id and section\_number.

**current\_next\_indicator** – A 1-bit field, which when set to '1' indicates that the private\_section sent is currently applicable. When the current\_next\_indicator is set to '1', then the version\_number shall be that of the currently applicable private\_section. When the bit is set to '0', it indicates that the private\_section sent is not yet applicable and shall be the next private\_section with the same section\_number and table\_id to become valid.

**section\_number** – This 8-bit field gives the number of the private\_section. The section\_number of the first section in a private table shall be 0x00. The section\_number shall be incremented by 1 with each additional section in this private table.

**last\_section\_number** – This 8-bit field specifies the number of the last section (that is, the section with the highest section\_number) of the private table of which this section is a part.

**CRC\_32** – This is a 32-bit field that contains the CRC value that gives a zero output of the registers in the decoder defined in Annex A after processing the entire private section.

**2.4.4.13 Syntax of the transport stream section**

Rec. ITU-T H.222.0 | ISO/IEC 13818-1 compliant bitstreams may carry the information defined in Table 2-36. Rec. ITU-T H.222.0 | ISO/IEC 13818-1 compliant decoders may decode the information defined in this table.

The transport stream description table is defined to support the carriage of descriptors as found in 2.6 for an entire transport stream. The descriptors shall apply to the entire transport stream. This table uses a table\_id value of 0x03 as specified in Table 2-31 and is carried in transport stream packets whose PID value is 0x0002 as specified in Table 2-3.

**Table 2-36 – The transport stream description table**

Syntax	No. of bits	Mnemonic
TS_description_section() {		
<b>table_id</b>	<b>8</b>	<b>uimsbf</b>
<b>section_syntax_indicator</b>	<b>1</b>	<b>bslbf</b>
'0'	<b>1</b>	<b>bslbf</b>
<b>reserved</b>	<b>2</b>	<b>bslbf</b>
<b>section_length</b>	<b>12</b>	<b>uimsbf</b>
<b>reserved</b>	<b>18</b>	<b>bslbf</b>
<b>version_number</b>	<b>5</b>	<b>uimsbf</b>
<b>current_next_indicator</b>	<b>1</b>	<b>bslbf</b>
<b>section_number</b>	<b>8</b>	<b>uimsbf</b>
<b>last_section_number</b>	<b>8</b>	<b>uimsbf</b>
for (i = 0; i < N; i++) {		
descriptor()		
}		
<b>CRC_32</b>	<b>32</b>	<b>rpchof</b>
}		

**2.4.4.14 Semantic definition of fields in the transport stream section**

**table\_id** – This is an 8-bit field, which shall be set to '0x03' as specified in Table 2-31.

**section\_length** – This is a 12-bit field, the first two bits of which shall be '00'. The remaining 10 bits specify the number of bytes of the section, starting immediately following the section\_length field, and including the CRC. The value in this field shall not exceed 1021 (0x3FD).

**version\_number** – This 5-bit field is the version number of the whole transport stream description table. The version number shall be incremented by 1 modulo 32 whenever the definition of the transport stream description table changes. When the current\_next\_indicator is set to '1', then the version\_number shall be that of the currently applicable transport stream description table. When the current\_next\_indicator is set to '0', then the version\_number shall be that of the next applicable transport stream description table.

**current\_next\_indicator** – A 1-bit indicator, which, when set to '1', indicates that the transport stream description table sent is currently applicable. When the bit is set to '0', it indicates that the table sent is not yet applicable and shall be the next table to become valid.

**section\_number** – This 8-bit field gives the number of this section. The section\_number of the first section in the transport stream description table shall be 0x00. It shall be incremented by 1 with each additional section in the transport stream description table.

**last\_section\_number** – This 8-bit field specifies the number of the last section (that is, the section with the highest section\_number) of the complete transport stream description table.

**CRC\_32** – This is a 32-bit field that contains the CRC value that gives a zero output of the registers in the decoder defined in Annex A after processing the entire transport stream description section.

## 2.5 Program stream bitstream requirements

### 2.5.1 Program stream coding structure and parameters

The Rec. ITU-T H.222.0 | ISO/IEC 13818-1 program stream coding layer allows one program of one or more elementary streams to be combined into a single stream. Data from each elementary stream are multiplexed together with information that allows synchronized presentation of the elementary streams within the program.

A program stream consists of one or more elementary streams from one program multiplexed together. Audio and video elementary streams consist of access units.

Elementary stream data is carried in PES packets. A PES packet consists of a PES packet header followed by packet data. PES packets are inserted into program stream packs.

The PES packet header begins with a 32-bit start-code that also identifies the stream (refer to Table 2-22) to which the packet data belongs. The PES packet header may contain just a presentation time stamp (PTS) or both a presentation timestamp and a decoding time stamp (DTS). The PES packet header also contains other optional fields. The packet data contains a variable number of contiguous bytes from one elementary stream.

In a program stream, PES packets are organized in packs. A pack commences with a pack header and is followed by zero or more PES packets. The pack header begins with a 32-bit start-code. The pack header is used to store timing and bitrate information.

The program stream begins with a system header that optionally may be repeated. The system header carries a summary of the system parameters defined in the stream.

This Recommendation | International Standard does not specify the coded data which may be used as part of conditional access systems. This Recommendation | International Standard does, however, provide mechanisms for program service providers to transport and identify this data for decoder processing, and to correctly reference data which are here specified.

### 2.5.2 Program stream system target decoder

The semantics of the program stream and the constraints on these semantics require exact definitions of decoding events and the times at which these events occur. The definitions needed are set out in this Specification using a hypothetical decoder known as the program stream system target decoder (P-STD).

The P-STD is a conceptual model used to define these terms precisely and to model the decoding process during the construction of program streams. The P-STD is defined only for this purpose. Neither the architecture of the P-STD nor the timing described precludes uninterrupted, synchronized playback of program streams from a variety of decoders with different architectures or timing schedules.

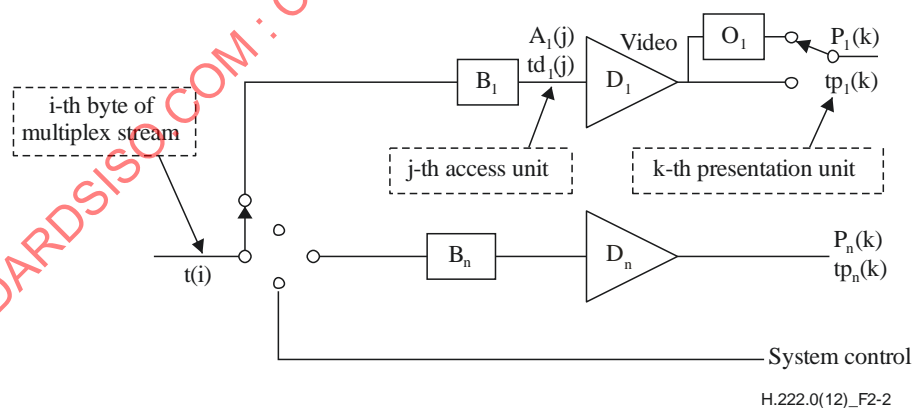

Figure 2-2 – Program stream system target decoder notation

The following notation is used to describe the program stream system target decoder and is partially illustrated in Figure 2-2.

$i, i'$  are indices to bytes in the program stream. The first byte has index 0.

$j$  is an index to access units in the elementary streams.

$k, k', k''$  are indices to presentation units in the elementary streams.

$n$  is an index to the elementary streams.

- t(i) indicates the time in seconds at which the i-th byte of the program stream enters the system target decoder. The value t(0) is an arbitrary constant.
- SCR(i) is the time encoded in the SCR field measured in units of the 27 MHz system clock where i is the byte index of the final byte of the system\_clock\_reference\_base field.
- A<sub>n</sub>(j) is the j-th access unit in elementary stream n. A<sub>n</sub>(j) is indexed in decoding order.
- td<sub>n</sub>(j) is the decoding time, measured in seconds, in the system target decoder of the j-th access unit in elementary stream n.
- P<sub>n</sub>(k) is the k-th presentation unit in elementary stream n. P<sub>n</sub>(k) is indexed in presentation order.
- tp<sub>n</sub>(k) is the presentation time, measured in seconds, in the system target decoder of the k-th presentation unit in elementary stream n.
- t is time measured in seconds.
- F<sub>n</sub>(t) is the fullness, measured in bytes, of the system target decoder input buffer for elementary stream n at time t.
- B<sub>n</sub> the input buffer in the system target decoder for elementary stream n.
- BS<sub>n</sub> is the size of the system target decoder input buffer, measured in bytes, for elementary stream n.
- D<sub>n</sub> is the decoder for elementary stream n.
- O<sub>n</sub> is the reorder buffer for video elementary stream n.

### 2.5.2.1 System clock frequency

Timing information referenced in P-STD is carried by several data fields defined in this Specification. The fields are defined in 2.5.3.3 and 2.4.3.6. This information is coded as the sampled value of a system clock.

The value of the system clock frequency is measured in Hz and shall meet the following constraints:

- 27 000 000 – 810 ≤ system\_clock\_frequency ≤ 27 000 000 + 810;
- rate of change of system\_clock\_frequency with time ≤ 75 × 10<sup>-3</sup> Hz/s.

The notation "system\_clock\_frequency" is used in several places in this Recommendation | International Standard to refer to the frequency of a clock meeting these requirements. For notational convenience, equations in which SCR, PTS, or DTS appear, lead to values of time which are accurate to some integral multiple of (300 × 2<sup>33</sup>/system\_clock\_frequency) seconds. This is due to the encoding of SCR timing information as 33 bits of 1/300 of the system clock frequency plus 9 bits for the remainder, and encoding as 33 bits of the system clock frequency divided by 300 for PTS and DTS.

### 2.5.2.2 Input to the program stream system target decoder

Data from the program stream enters the system target decoder. The i-th byte enters at time t(i). The time at which this byte enters the system target decoder can be recovered from the input stream by decoding the input system clock reference (SCR) fields and the program\_mux\_rate field encoded in the pack header. The SCR, as defined in equation 2-18, is coded in two parts: one, in units the period of 1/300 × the system clock frequency, called system\_clock\_reference\_base (see equation 2-19), and one, called system\_clock\_reference\_ext equation (see equation 2-20), in units of the period of the system clock frequency. In the following the values encoded in these fields are denoted by SCR\_base(i) and SCR\_ext(i). The value encoded in the SCR field indicates time t(i), where i refers to the byte containing the last bit of the system\_clock\_reference\_base field.

Specifically:

$$SCR(i) = SCR\_base(i) \times 300 + SCR\_ext(i) \quad (2-18)$$

where:

$$SCR\_base(i) = ((system\_clock\_frequency \times t(i)) \text{DIV } 300) \% 2^{33} \quad (2-19)$$

$$SCR\_ext(i) = ((system\_clock\_frequency \times t(i)) \text{DIV } 1) \% 300 \quad (2-20)$$

The input arrival time, t(i), as given in equation 2-21, for all other bytes shall be constructed from SCR(i) and the rate at which data arrives, where the arrival rate within each pack is the value represented in the program\_mux\_rate field in that pack's header.

$$t(i) = \frac{SCR(i')}{system\_clock\_frequency} + \frac{i - i'}{program\_mux\_rate \times 50} \quad (2-21)$$

where:

- $i'$  is the index of the byte containing the last bit of the system\_clock\_reference\_base field in the pack header
- $i$  is the index of any byte in the pack, including the pack header
- $SCR(i')$  is the time encoded in the system clock reference base and extension fields in units of the system clock
- $program\_mux\_rate$  is a field defined in 2.5.3.3.

After delivery of the last byte of a pack there may be a time interval during which no bytes are delivered to the input of the P-STD.

### 2.5.2.3 Buffering

The PES packet data from elementary stream  $n$  is passed to the input buffer for stream  $n$ ,  $B_n$ . Transfer of byte  $i$  from the system target decoder input to  $B_n$  is instantaneous, so that byte  $i$  enters the buffer for stream  $n$ , of size  $BS_n$ , at time  $t(i)$ .

Bytes present in the pack header, system headers, program stream maps, program stream directories, or PES packet headers of the program stream such as SCR, DTS, PTS, and packet\_length fields, are not delivered to any of the buffers, but may be used to control the system.

The input buffer sizes  $BS_1$  through  $BS_n$  are given by the P-STD buffer size parameter in the syntax in equations 2-16 and 2-17.

At the decoding time,  $td_n(j)$ , all data for the access unit that has been in the buffer longest,  $A_n(j)$ , and any stuffing bytes that immediately precede it that are present in the buffer at the time  $td_n(j)$ , are removed instantaneously at time  $td_n(j)$ . The decoding time  $td_n(j)$  is specified in the DTS or PTS fields. Decoding times  $td_n(j + 1)$ ,  $td_n(j + 2)$ , ... of access units without encoded DTS or PTS fields which directly follow access unit  $j$  may be derived from information in the elementary stream. Refer to Annex C of Rec. ITU-T H.262 | ISO/IEC 13818-2, ISO/IEC 13818-3, ISO/IEC 11172-2 or ISO/IEC 11172-3. Also refer to 2.7.5. As the access unit is removed from the buffer, it is instantaneously decoded to a presentation unit.

The program stream shall be constructed, and  $t(i)$  shall be chosen so that the input buffers of size  $BS_1$  through  $BS_n$  neither overflow nor underflow in the program system target decoder. That is:

$$0 \leq F_n(t) \leq BS_n$$

for all  $t$  and  $n$ ,

and:

$$F_n(t) = 0$$

instantaneously before  $t = t(0)$ .

$F_n(t)$  is the instantaneous fullness of P-STD buffer  $B_n$ .

An exception to this condition is that the P-STD buffer  $B_n$  may underflow when the low\_delay flag in the video sequence header is set to '1' (refer to 2.4.2.7) or when trick\_mode status is true (refer to 2.4.3.8).

For all program streams, the delay caused by system target decoder input buffering shall be less than or equal to one second except for still picture video data and ISO/IEC 14496 streams. The input buffering delay is the difference in time between a byte entering the input buffer and when it is decoded.

Specifically: in the case of no still picture video data and no ISO/IEC 14496 stream the delay is constrained by:

$$td_n(j) - t(i) \leq 1 \text{ s}$$

in the case of still picture video data the delay is constrained by:

$$td_n(j) - t(i) \leq 60 \text{ s}$$

in the case of ISO/IEC 14496 streams the delay is constrained by:

$$tdn(j) - t(i) \leq 10 \text{ s}$$

for all bytes contained in access unit  $j$ .

For program streams, all bytes of each pack shall enter the P-STD before any byte of a subsequent pack.

When the **low\_delay** flag in the video sequence extension is set to '1' (refer to 6.2.2.3 of Rec. ITU-T H.262 | ISO/IEC 13818-2), the VBV buffer may underflow. In this case when the P-STD elementary stream buffer  $B_n$  is examined at the time specified by  $tdn(j)$ , the complete data for the access unit may not be present in the buffer  $B_n$ . When this case arises, the buffer shall be re-examined at intervals of two field-periods until the data for the complete access unit is present in the buffer. At this time the entire access unit shall be removed from buffer  $B_n$  instantaneously.

VBV buffer underflow is allowed to occur continuously without limit. The P-STD decoder shall remove access unit data from buffer  $B_n$  at the earliest time consistent with the paragraph above and any DTS or PTS values encoded in the bitstream. The decoder may be unable to re-establish correct decoding and display times as indicated by DTS and PTS until the VBV buffer underflow situation ceases and a PTS or DTS is found in the bitstream.

#### 2.5.2.4 PES streams

It is possible to construct a stream of data as a contiguous stream of PES packets each containing data of the same elementary stream and with the same stream\_id. Such a stream is called a PES stream. The PES-STD model for a PES stream is identical to that for the program stream, with the exception that the Elementary Stream Clock Reference (ESCR) is used in place of the SCR, and ES\_rate in place of program\_mux\_rate. The demultiplexor sends data to only one elementary stream buffer.

NOTE – In the following equations, unit conversion should be implicitly performed as appropriate.

As a PES stream only carries a single elementary stream, the buffer sizes in the PES-STD do not account for multiplexing with other elementary streams, but only for multiplexing of the elementary stream carried in the PES stream with PES headers, pack headers and system headers.

Buffer sizes  $BS_n$  in the PES-STD model are defined as follows:

- For Rec. ITU-T H.262 | ISO/IEC 13818-2 video:

$$BS_n = VBV_{\max}[\text{profile, level}] + BS_{\text{oh}}$$

$BS_{\text{oh}} = (1/750) \text{ seconds} \times R_{\max}[\text{profile, level}]$ , where  $VBV_{\max}[\text{profile, level}]$  and  $R_{\max}[\text{profile, level}]$  are the maximum VBV size and bit rate per profile, level, and layer as defined in Tables 8-14 and 8-13, respectively, of Rec. ITU-T H.262 | ISO/IEC 13818-2.  $BS_{\text{oh}}$  is allocated for PES packet header overhead.

- For ISO/IEC 11172-2 video:

$$BS_n = VBV_{\max} + BS_{\text{oh}}$$

$BS_{\text{oh}} = (1/750) \text{ seconds} \times R_{\max}$ , where  $R_{\max}$  and  $vbv_{\max}$  refer to the maximum bitrate and maximum  $vbv_{\text{buffer}}$  size for a constrained parameter bitstream in ISO/IEC 11172-2 respectively.

- For ISO/IEC 11172-3 or ISO/IEC 13818-3 audio:

$$BS_n = 2848 \text{ bytes}$$

For ISO/IEC 13818-7 ADTS audio:

$$\begin{aligned} BS_n &= 2848 \text{ bytes if 1-2 channels} \\ BS_n &= 7200 \text{ bytes if 3-8 channels} \\ BS_n &= 10800 \text{ bytes if 9-12 channels} \\ BS_n &= 43200 \text{ bytes if 13-48 channels} \end{aligned}$$

Note that the above numbers differ from the  $BS_n$  numbers specified in 2.4.3.2 due to the fact that a PES stream carries a single elementary stream only.

- For ISO/IEC 14496-3 audio, except for ISO/IEC 14496-3 DST, ALS and SLS:

$$\begin{aligned} BS_n &= 2848 \text{ bytes if 1-2 channels} \\ BS_n &= 7200 \text{ bytes if 3-8 channels} \end{aligned}$$

$$\begin{aligned} BS_n &= 10800 \text{ bytes if 9-12 channels} \\ BS_n &= 43200 \text{ bytes if 13-48 channels} \end{aligned}$$

Note that the above numbers differ from the  $BS_n$  numbers specified in 2.11.2.2 due to the fact that a PES stream carries a single elementary stream only.

- For ISO/IEC 14496-3 DST-64 audio:

$$\begin{aligned} BS_n &= 5000 \times (\text{number of channels}) \text{ bytes; hence for stereo } BS_n = 10\,000 \text{ bytes} \\ &\text{and for 5.1 surround sound audio } BS_n = 30\,000 \text{ bytes} \end{aligned}$$

- For ISO/IEC 14496-3 DST-128 audio:

$$\begin{aligned} BS_n &= 10\,000 \times (\text{number of channels}) \text{ bytes; hence for stereo } BS_n = 20\,000 \text{ bytes} \\ &\text{and for 5.1 surround sound audio } BS_n = 60\,000 \text{ bytes} \end{aligned}$$

- For ISO/IEC 14496-3 DST-256 audio:

$$\begin{aligned} BS_n &= 20\,000 \times (\text{number of channels}) \text{ bytes; hence for stereo } BS_n = 40\,000 \text{ bytes} \\ &\text{and for 5.1 surround sound audio } BS_n = 120\,000 \text{ bytes} \end{aligned}$$

- For ISO/IEC 14496-3 ALS and SLS audio:

$$\begin{aligned} BS_n &= 33\,000 \times (\text{number of channels}) \text{ bytes; hence for stereo } BS_n = 66\,000 \text{ bytes} \\ &\text{and for 5.1 surround sound audio } BS_n = 198\,000 \text{ bytes} \end{aligned}$$

- For Rec. ITU-T H.264 | ISO/IEC 14496-10 video:

$$BS_n = 1200 \times \text{MaxCPB}[\text{level}] + BS_{oh}$$

where  $\text{MaxCPB}[\text{level}]$  is defined in Table A.1 (Level Limits) in Rec. ITU-T H.264 | ISO/IEC 14496-10 for each level.

### 2.5.2.5 Decoding and presentation

Decoding and presentation in the program stream system target decoder are the same as defined for the transport stream system target decoder in 2.4.2.5 and 2.4.2.6 respectively.

### 2.5.2.6 P-STD extensions for carriage of ISO/IEC 14496 data

For decoding of ISO/IEC 14496 data carried in a program stream the P-STD model is extended. For decoding of individual ISO/IEC 14496 elementary streams in the P-STD see 2.11.2. Clause 2.11.3 defines P-STD extensions and parameters for decoding of ISO/IEC 14496 scenes and associated streams.

### 2.5.2.7 P-STD extensions for carriage of Rec. ITU-T H.264 | ISO/IEC 14496-10 video

For decoding of AVC video streams conforming to one or more profiles defined in Annex A of Rec. ITU-T H.264 | ISO/IEC 14496-10 video streams carried in a program stream in the P-STD model, see 2.14.3.2, for decoding of AVC video streams conforming to one or more profiles defined in Annex G of Rec. ITU-T H.264 | ISO/IEC 14496-10 carried in a program stream in the P-STD model, see 2.14.3.6 and for decoding of AVC video streams conforming to one or more profiles defined in Annex H of Rec. ITU-T H.264 | ISO/IEC 14496-10 carried in a program stream in the P-STD model, see 2.14.3.8.

### 2.5.2.8 P-STD extensions for carriage of ISO/IEC 14496-17 text streams

For decoding of ISO/IEC 14496-17 text streams carried in a program stream in the P-STD model, see 2.15.3.2.

## 2.5.3 Specification of the program stream syntax and semantics

The following syntax describes a stream of bytes.

### 2.5.3.1 Program stream

See Table 2-37.

**Table 2-37 – Program stream**

Syntax	No. of bits	Mnemonic
<pre>MPEG2_program_stream() {     do {         pack()     } while (nextbits() == pack_start_code)     MPEG_program_end_code }</pre>	32	bslbf

**2.5.3.2 Semantic definition of fields in program stream**

**MPEG\_program\_end\_code** – The MPEG\_program\_end\_code is the bit string '0000 0000 0000 0000 0000 0001 1011 1001' (0x000001B9). It terminates the program stream.

**2.5.3.3 Pack layer of program stream**

See Tables 2-38 and 2-39.

**Table 2-38 – Program stream pack**

Syntax	No. of bits	Mnemonic
<pre>pack() {     pack_header()     while (nextbits() == packet_start_code_prefix) {         PES_packet()     } }</pre>		

STANDARDSISO.COM : Click to view the full PDF of ISO/IEC 13818-1:2023

Table 2-39 – Program stream pack header

Syntax	No. of bits	Mnemonic
pack_header() {		
<b>pack_start_code</b>	32	bslbf
'01'	2	bslbf
<b>system_clock_reference_base</b> [32..30]	3	bslbf
<b>marker_bit</b>	1	bslbf
<b>system_clock_reference_base</b> [29..15]	15	bslbf
<b>marker_bit</b>	1	bslbf
<b>system_clock_reference_base</b> [14..0]	15	bslbf
<b>marker_bit</b>	1	bslbf
<b>system_clock_reference_extension</b>	9	uimsbf
<b>marker_bit</b>	1	bslbf
<b>program_mux_rate</b>	22	uimsbf
<b>marker_bit</b>	1	bslbf
<b>marker_bit</b>	1	bslbf
<b>reserved</b>	5	bslbf
<b>pack_stuffing_length</b>	3	uimsbf
for (i = 0; i < pack_stuffing_length; i++) {		
stuffing_byte	8	bslbf
}		
if (nextbits() == system_header_start_code) {		
system_header ()		
}		
}		

#### 2.5.3.4 Semantic definition of fields in program stream pack

**pack\_start\_code** – The pack\_start\_code is the bit string '0000 0000 0000 0000 0000 0001 1011 1010' (0x000001BA). It identifies the beginning of a pack.

**system\_clock\_reference\_base; system\_clock\_reference\_extension** – The system clock reference (SCR) is a 42-bit field coded in two parts. The first part, system\_clock\_reference\_base, is a 33-bit field whose value is given by SCR\_base(i) as given in equation 2-19. The second part, system\_clock\_reference\_extension, is a 9-bit field whose value is given by SCR\_ext(i), as given in equation 2-20. The SCR indicates the intended time of arrival of the byte containing the last bit of the system\_clock\_reference\_base at the input of the program target decoder.

The frequency of coding requirements for the SCR field are given in 2.7.1.

**marker\_bit** – A marker\_bit is a 1-bit field that has the value '1'.

**program\_mux\_rate** – This is a 22-bit integer specifying the rate at which the P-STD receives the program stream during the pack in which it is included. The value of program\_mux\_rate is measured in units of 50 bytes/second. The value '0' is forbidden. The value represented in program\_mux\_rate is used to define the time of arrival of bytes at the input to the P-STD in 2.5.2. The value encoded in the program\_mux\_rate field may vary from pack to pack in a Rec. ITU-T H.222.0 | ISO/IEC 13818-1 program multiplexed stream.

**pack\_stuffing\_length** – A 3-bit integer specifying the number of stuffing bytes which follow this field.

**stuffing\_byte** – This is a fixed 8-bit value equal to '1111 1111' that can be inserted by the encoder, for example to meet the requirements of the channel. It is discarded by the decoder. In each pack header no more than 7 stuffing bytes shall be present.

#### 2.5.3.5 System header

See Table 2-40.

Table 2-40 – Program stream system header

Syntax	No. of bits	Mnemonic
system_header () {		
system_header_start_code	32	bslbf
header_length	16	uimsbf
marker_bit	1	bslbf
rate_bound	22	uimsbf
marker_bit	1	bslbf
audio_bound	6	uimsbf
fixed_flag	1	bslbf
CSPS_flag	1	bslbf
system_audio_lock_flag	1	bslbf
system_video_lock_flag	1	bslbf
marker_bit	1	bslbf
video_bound	5	uimsbf
packet_rate_restriction_flag	1	bslbf
reserved_bits	7	bslbf
while (nextbits () == '1') {		
stream_id	8	uimsbf
if (stream_id == '1011 0111') {		
'11'	2	bslbf
'000 0000'	7	bslbf
stream_id_extension	7	uimsbf
'1011 0110'	8	bslbf
'11'	2	bslbf
P-STD_buffer_bound_scale	1	bslbf
P-STD_buffer_size_bound	13	uimsbf
}		
else {		
'11'	2	bslbf
P-STD_buffer_bound_scale	1	bslbf
P-STD_buffer_size_bound	13	uimsbf
}		
}		
}		

### 2.5.3.6 Semantic definition of fields in system header

**system\_header\_start\_code** – The system\_header\_start\_code is the bit string '0000 0000 0000 0000 0000 0001 1011 1011' (0x000001BB). It identifies the beginning of a system header.

**header\_length** – This 16-bit field indicates the length in bytes of the system header following the header\_length field. Future extensions of this Specification may extend the system header.

**rate\_bound** – A 22-bit field. The rate\_bound is an integer value greater than or equal to the maximum value of the program\_mux\_rate field coded in any pack of the program stream. It may be used by a decoder to assess whether it is capable of decoding the entire stream.

**audio\_bound** – A 6-bit field. The audio\_bound is an integer in the inclusive range from 0 to 32 and is set to a value greater than or equal to the maximum number of ISO/IEC 13818-3 and ISO/IEC 11172-3 audio streams in the program stream for which the decoding processes are simultaneously active. For the purpose of this subclause, the decoding process of an ISO/IEC 13818-3 or ISO/IEC 11172-3 audio stream is active if the STD buffer is not empty or if a Presentation Unit is being presented in the P-STD model.

**fixed\_flag** – The fixed\_flag is a 1-bit flag. When set to '1' fixed bitrate operation is indicated. When set to '0' variable bitrate operation is indicated. During fixed bitrate operation, the value encoded in all system\_clock\_reference fields in the multiplexed Rec. ITU-T H.222.0 | ISO/IEC 13818-1 stream shall adhere to the following linear equation:

$$SCR\_base(i) = ((c1 \times i + c2) \text{ DIV } 300) \% 2^{33} \quad (2-22)$$

$$SCR\_ext(i) = ((c1 \times i + c2) \text{ DIV } 300) \% 300 \quad (2-23)$$

where:

- c1 is a real-valued constant valid for all i.
- c2 is a real-valued constant valid for all i.
- i is the index in the Rec. ITU-T H.222.0 | ISO/IEC 13818-1 multiplexed stream of the byte containing the final bit of any system\_clock\_reference field in the stream.

**CSPS\_flag** – The CSPS\_flag is a 1-bit field. If its value is set to '1' the program stream meets the constraints defined in 2.7.9.

**system\_audio\_lock\_flag** – The system\_audio\_lock\_flag is a 1-bit field indicating that there is a specified, constant rational relationship between the audio sampling rate and the system\_clock\_frequency in the system target decoder. The system\_clock\_frequency is defined in 2.5.2.1 and the audio sampling rate is specified in ISO/IEC 13818-3. The system\_audio\_lock\_flag may only be set to '1' if, for all presentation units in all audio elementary streams in the program stream, the ratio of system\_clock\_frequency to the actual audio sampling rate, SCASR, is constant and equal to the value indicated in the following table at the nominal sampling rate indicated in the audio stream.

$$SCASR = \frac{system\_clock\_frequency}{audio\_sample\_rate\_in\_the\_P - STD} \tag{2-24}$$

The notation  $\frac{X}{Y}$  denotes real division.

Nominal audio sampling frequency (kHz)	16	32	22.05	44.1	24	48
SCASR	$\frac{27\,000\,000}{16\,000}$	$\frac{27\,000\,000}{32\,000}$	$\frac{27\,000\,000}{22\,050}$	$\frac{27\,000\,000}{44\,100}$	$\frac{27\,000\,000}{24\,000}$	$\frac{27\,000\,000}{48\,000}$

**system\_video\_lock\_flag** – The system\_video\_lock\_flag is a 1-bit field indicating that there is a specified, constant rational relationship between the video time base and the system clock frequency in the system target decoder. The system\_video\_lock\_flag may only be set to '1' if, for all presentation units in all video elementary streams in the Rec. ITU-T H.222.0 | ISO/IEC 13818-1 program, the ratio of system\_clock\_frequency to the frequency of the actual video time base is constant.

For ISO/IEC 11172-2 and Rec. ITU-T H.262 | ISO/IEC 13818-2 video streams, if the system\_video\_lock\_flag is set to '1', then the ratio of system\_clock\_frequency to the actual video frame rate, SCFR, shall be constant and equal to the value indicated in the following table at the nominal frame rate indicated in the video stream.

For ISO/IEC 14496-2 video streams, if the system\_video\_lock\_flag is set to '1', then the time base of the ISO/IEC 14496-2 video stream, as defined by vop\_time\_increment\_resolution, shall be locked to the STC and shall be exactly equal to N times system\_clock\_frequency divided by K, with N and K integers that have a fixed value within each visual object sequence, with K greater than or equal to N.

For Rec. ITU-T H.264 | ISO/IEC 14496-10 video streams, the frequency of the AVC time base is defined by the AVC parameter time\_scale. If the system\_video\_lock\_flag is set to '1' for an AVC video stream or for a video sub-bitstream, then the frequency of the AVC time base shall be locked to the STC and shall be exactly equal to N times system\_clock\_frequency divided by K, with N and K integers that have a fixed value within each AVC video sequence, with K greater than or equal to N.

$$SCFR = \frac{system\_clock\_frequency}{frame\_rate\_in\_the\_P - STD} \tag{2-25}$$

Nominal frame rate (Hz)	23.976	24	25	29.97	30	50	59.94	60
SCFR	1 126 125	1 125 000	1 080 000	900 900	900 000	540 000	450 450	450 000

The values of the ratio SCFR are exact. The actual frame rate differs slightly from the nominal rate in cases where the nominal rate is 23.976, 29.97, or 59.94 frames per second.

**video\_bound** – The video\_bound is a 5-bit integer in the inclusive range from 0 to 16 and is set to a value greater than or equal to the maximum number of video streams in the program stream of which the decoding processes are simultaneously active. For the purpose of this subclause, the decoding process of a video stream is active if one of the buffers in the P-STD model is not empty, or if a Presentation Unit is being presented in the P-STD model.

**packet\_rate\_restriction\_flag** – The packet\_rate\_restriction\_flag is a 1-bit flag. If the CSPS flag is set to '1', the packet\_rate\_restriction\_flag indicates which constraint is applicable to the packet rate, as specified in 2.7.9. If the CSPS flag is set to value of '0', then the meaning of the packet\_rate\_restriction\_flag is undefined.

**reserved\_bits** – This 7-bit field is reserved for future use by ISO/IEC. Until otherwise specified by ITU-T | ISO/IEC it shall have the value '111 1111'.

**stream\_id** – The stream\_id is an 8-bit field that indicates the coding and elementary stream number of the stream to which the following P-STD\_buffer\_bound\_scale and P-STD\_buffer\_size\_bound fields refer.

If stream\_id equals '1011 1000' the P-STD\_buffer\_bound\_scale and P-STD\_buffer\_size\_bound fields following the stream\_id refer to all audio streams in the program stream.

If stream\_id equals '1011 1001' the P-STD\_buffer\_bound\_scale and P-STD\_buffer\_size\_bound fields following the stream\_id refer to all video streams in the program stream.

If stream\_id equals '1111 1101', the P-STD\_buffer\_bound\_scale and P-STD\_buffer\_size\_bound fields following the stream\_id refer to all elementary streams with an extended\_stream\_id in the program stream, independent of the coded value of the stream\_id\_extension in the PES header of those streams.

If stream\_id equals '1011 0111', the following stream\_id\_extension field shall be interpreted as referring to the stream coding and elementary stream number according to Table 2-27.

If the stream\_id takes on any other value it shall be a byte value greater than or equal to '1011 1100' and shall be interpreted as referring to the stream coding and elementary stream number according to Table 2-22.

Each elementary stream present in the program stream shall have its P-STD\_buffer\_bound\_scale and P-STD\_buffer\_size\_bound specified exactly once by this mechanism in each system header.

**stream\_id\_extension** – The stream\_id\_extension is a 7-bit field. In case the stream\_id field is coded with the value '1011 0111', then the stream\_id\_extension indicates the coding and elementary stream number of the stream with an extended\_stream\_id to which the P-STD\_buffer\_bound\_scale and P-STD\_buffer\_size\_bound fields following the stream\_id\_extension field refer.

**P-STD\_buffer\_bound\_scale** – The P-STD\_buffer\_bound\_scale is a 1-bit field that indicates the scaling factor used to interpret the subsequent P-STD\_buffer\_size\_bound field. If the preceding stream\_id indicates an audio stream, P-STD\_buffer\_bound\_scale shall have the value '0'. If the preceding stream\_id indicates a video stream, P-STD\_buffer\_bound\_scale shall have the value '1'. For all other stream types, the value of the P-STD\_buffer\_bound\_scale may be either '1' or '0'.

**P-STD\_buffer\_size\_bound** – The P-STD\_buffer\_size\_bound is a 13-bit unsigned integer defining a value greater than or equal to the maximum P-STD input buffer size,  $BS_n$ , over all packets for stream  $n$  in the program stream. If P-STD\_buffer\_bound\_scale has the value '0', then P-STD\_buffer\_size\_bound measures the buffer size bound in units of 128 bytes. If P-STD\_buffer\_bound\_scale has the value '1', then P-STD\_buffer\_size\_bound measures the buffer size bound in units of 1024 bytes. Thus:

$$\begin{aligned} & \text{if } (P - \text{STD\_buffer\_bound\_scale} == 0) \\ & \quad BS_n \leq P - \text{STD\_buffer\_size\_bound} \times 128 \end{aligned}$$

else:

$$BS_n \leq P - \text{STD\_buffer\_size\_bound} \times 1024$$

### 2.5.3.7 Packet layer of program stream

The packet layer of the program stream is defined by the PES packet layer in 2.4.3.6.

### 2.5.4 Program stream map

The Program Stream Map (PSM) provides a description of the elementary streams in the program stream and their relationship to one another. When carried in a transport stream this structure shall not be modified. The PSM is present as a PES packet when the stream\_id value is 0xBC (refer to Table 2-22).

NOTE – This syntax differs from the PES packet syntax described in 2.4.3.6.

Definition for the descriptor() fields may be found in 2.6.

#### 2.5.4.1 Syntax of program stream map

See Table 2-41.

Table 2-41 – Program stream map

Syntax	No. of bits	Mnemonic
program_stream_map() {		
packet_start_code_prefix	24	bslbf
map_stream_id	8	uimsbf
program_stream_map_length	16	uimsbf
current_next_indicator	1	bslbf
single_extension_stream_flag	1	bslbf
reserved	1	bslbf
program_stream_map_version	5	uimsbf
reserved	7	bslbf
marker_bit	1	bslbf
program_stream_info_length	16	uimsbf
for (i = 0; i < N; i++) {		
descriptor()		
}		
elementary_stream_map_length	16	uimsbf
for (i = 0; i < N1; i++) {		
stream_type	8	uimsbf
elementary_stream_id	8	uimsbf
elementary_stream_info_length	16	Uimsbf
if ( elementary_stream_id == 0xFD &&		
single_extension_stream_flag == 0) {		
pseudo_descriptor_tag	8	Uimsbf
pseudo_descriptor_length	8	Uimsbf
marker_bit	1	Bslbf
elementary_stream_id_extension	7	Uimsbf
for (i = 3; i < N2; i++) {		
descriptor()		
}		
}		
else {		
for (i = 0; i < N2; i++) {		
descriptor()		
}		
}		
}		
CRC_32	32	rpchof
}		

#### 2.5.4.2 Semantic definition of fields in program stream map

**packet\_start\_code\_prefix** – The packet\_start\_code\_prefix is a 24-bit code. Together with the map\_stream\_id that follows it constitutes a packet start code that identifies the beginning of a packet. The packet\_start\_code\_prefix is the bit string '0000 0000 0000 0000 0000 0001' (0x000001 in hexadecimal).

**map\_stream\_id** – This is an 8-bit field whose value shall be 0xBC.

**program\_stream\_map\_length** – The program\_stream\_map\_length is a 16-bit field indicating the total number of bytes in the program\_stream\_map immediately following this field. The maximum value of this field is 1018 (0x3FA).

**single\_extension\_stream\_flag** – This is a 1-bit field indicating, when set to '1', that the program stream contains at most one elementary stream with stream\_id equal to 0xFD.

**current\_next\_indicator** – This is a 1-bit field, when set to '1' indicates that the program stream map sent is currently applicable. When the bit is set to '0', it indicates that the program stream map sent is not yet applicable and shall be the next table to become valid.

**program\_stream\_map\_version** – This 5-bit field is the version number of the whole program stream map. The version number shall be incremented by 1 modulo 32 whenever the definition of the program stream map changes. When the current\_next\_indicator is set to '1', then the program\_stream\_map\_version shall be that of the currently applicable program stream map. When the current\_next\_indicator is set to '0', then the program\_stream\_map\_version shall be that of the next applicable program stream map.

**program\_stream\_info\_length** – The `program_stream_info_length` is a 16-bit field indicating the total length of the descriptors immediately following this field.

**marker\_bit** – A `marker_bit` is a 1-bit field that has the value '1'.

**elementary\_stream\_map\_length** – This is a 16-bit field specifying the total length, in bytes, of all elementary stream information in this program stream map. It includes the `stream_type`, `elementary_stream_id`, and `elementary_stream_info_length` fields.

**stream\_type** – This 8-bit field specifies the type of the stream according to Table 2-34. The `stream_type` field shall only identify elementary streams contained in PES packets. A value of 0x05 is prohibited.

**elementary\_stream\_id** – The `elementary_stream_id` is an 8-bit field indicating the value of the `stream_id` field in the PES packet headers of PES packets in which this elementary stream is stored. When `elementary_stream_id` is equal to 0xFD, the following applies:

- If `single_extension_stream_flag` is equal to 1, this indicates that the program stream contains only one elementary stream with `stream_id` equal to 0xFD. Note that the type of this elementary stream is signalled by the encoded value of the `stream_id_extension` field in the PES headers of PES packets carrying this elementary stream.
- Otherwise (`single_extension_stream_flag` is equal to 0), the `elementary_stream_id_extension` field is present to identify the elementary stream.

**elementary\_stream\_info\_length** – The `elementary_stream_info_length` is a 16-bit field indicating the length in bytes of the descriptors and, when present, the `pseudo_descriptor_tag`, the `pseudo_descriptor_length`, and the `elementary_stream_id_extension` (and associated `marker_bit`) data immediately following this field.

**pseudo\_descriptor\_tag** – This is an 8-bit unsigned integer that shall be coded with the value 0x01; note that the use of value 0x01 for descriptor tags is forbidden in Table 2-45.

**pseudo\_descriptor\_length** – The `pseudo_descriptor_length` is an 8-bit unsigned integer that shall be coded with the value 1.

**elementary\_stream\_id\_extension** – This 7-bit field, when present, indicates the encoded value of the `elementary_stream_id_extension` field in the PES packet headers of PES packets in which this elementary stream is stored.

**CRC\_32** – This is a 32-bit field that contains the CRC value that gives a zero output of the registers in the decoder defined in Annex A after processing the entire program stream map.

### 2.5.5 Program stream directory

The directory for an entire stream is made up of all the directory data carried by program stream directory packets identified with the `directory_stream_id`. The syntax for program stream directory packets is defined in Table 2-42.

NOTE 1 – This syntax differs from the PES packet syntax described in 2.4.3.6.

Directory entries may be required to reference I-pictures in a video stream as defined in Rec. ITU-T H.262 | ISO/IEC 13818-2 and ISO/IEC 11172-2. If an I-picture that is referenced in a directory entry is preceded by a sequence header with no intervening picture headers, the directory entry shall reference the first byte of the sequence header. If an I-picture that is referenced in a directory entry is preceded by a group of pictures header with no intervening picture headers and no immediately preceding sequence header, the directory entry shall reference the first byte of the group of pictures header. Any other picture that a directory entry references shall be referenced by the first byte of the picture header.

NOTE 2 – It is recommended that I-pictures immediately following a sequence header should be referenced in directory structures so that the directory contains an entry at every point where the decoder may be reset completely.

For AVC video streams conforming to one or more profiles defined in Annex A of Rec. ITU-T H.264 | ISO/IEC 14496-10, directory entries may be required to reference IDR picture or pictures associated with a recovery point SEI message in an AVC video stream. Each such directory entry shall refer to the first byte of an AVC access unit.

For video sub-bitstreams of AVC video streams conforming to one or more profiles defined in Annex G of Rec. ITU-T H.264 | ISO/IEC 14496-10, directory entries may be required to reference IDR picture or pictures to be re-assembled from video sub-bitstreams and associated with a recovery point SEI message present in a video sub-bitstream. Each such directory entry shall refer to the first byte of an SVC dependency representation.

For MVC video sub-bitstreams of AVC video streams conforming to one or more profiles defined in Annex H of Rec. ITU-T H.264 | ISO/IEC 14496-10, directory entries may be required to reference IDR picture or pictures to be re-assembled from MVC video sub-bitstreams and associated with a recovery point SEI message present in an MVC video sub-bitstream. Each such directory entry shall refer to the first byte of an MVC view-component subset.

Directory references to audio streams as defined in ISO/IEC 13818-3 and ISO/IEC 11172-3 shall be the syncword of the audio frame.

NOTE 3 – It is recommended that the distance between referenced access units not exceed half a second.

Access units shall be referenced in a program\_stream\_directory packet in the same order that they appear in the bitstream.

### 2.5.5.1 Syntax of program stream directory packet

See Table 2-42.

Table 2-42 – Program stream directory packet

Syntax	No. of bits	Mnemonic
directory_PES_packet(){		
packet_start_code_prefix	24	bslbf
directory_stream_id	8	uimsbf
PES_packet_length	16	uimsbf
number_of_access_units	15	uimsbf
marker_bit	1	bslbf
prev_directory_offset[44..30]	15	uimsbf
marker_bit	1	bslbf
prev_directory_offset[29..15]	15	uimsbf
marker_bit	1	bslbf
prev_directory_offset[14..0]	15	uimsbf
marker_bit	1	bslbf
next_directory_offset[44..30]	15	uimsbf
marker_bit	1	bslbf
next_directory_offset[29..15]	15	uimsbf
marker_bit	1	bslbf
next_directory_offset[14..0]	15	uimsbf
marker_bit	1	bslbf
for (i = 0; i < number_of_access_units; i++) {		
packet_stream_id	8	uimsbf
PES_header_position_offset_sign	1	tcimsbf
PES_header_position_offset[43..30]	14	uimsbf
marker_bit	1	bslbf
PES_header_position_offset[29..15]	15	uimsbf
marker_bit	1	bslbf
PES_header_position_offset[14..0]	15	uimsbf
marker_bit	1	bslbf
reference_offset	16	uimsbf
marker_bit	1	bslbf
if (packet_stream_id == 0xFD) {		
packet_stream_id_extension_msbs	3	uimsbf
}		
else {		
reserved	3	bslbf
}		
PTS[32..30]	3	uimsbf
marker_bit	1	bslbf
PTS[29..15]	15	uimsbf
marker_bit	1	bslbf
PTS[14..0]	15	uimsbf
marker_bit	1	bslbf
bytes_to_read[22..8]	15	uimsbf
marker_bit	1	bslbf
bytes_to_read[7..0]	8	uimsbf
marker_bit	1	bslbf
intra_coded_indicator	1	bslbf
coding_parameters_indicator	2	bslbf
if (packet_stream_id == 0xFD) {		
packet_stream_id_extension_lsbs	4	uimsbf
}		
else {		
reserved	4	bslbf
}		
}		
}		

**2.5.5.2 Semantic definition of fields in program stream directory**

**packet\_start\_code\_prefix** – The packet\_start\_code\_prefix is a 24-bit code. Together with the stream\_id that follows, it constitutes a packet start code that identifies the beginning of a packet. The packet\_start\_code\_prefix is the bit string '0000 0000 0000 0000 0000 0001' (0x000001 in hexadecimal).

**directory\_stream\_id** – This 8-bit field shall have a value '1111 1111' (0xFF).

**PES\_packet\_length** – The PES\_packet\_length is a 16-bit field indicating the total number of bytes in the program\_stream\_directory immediately following this field (refer to Table 2-21).

**number\_of\_access\_units** – This 15-bit field is the number of access\_units that are referenced in this Directory PES packet.

**prev\_directory\_offset** – This 45-bit unsigned integer gives the byte address offset of the first byte of the packet start code of the previous program stream directory packet. This address offset is relative to the first byte of the start code of the packet which contains this prev\_directory\_offset field. The value '0' indicates that there is no previous program stream directory packet.

**next\_directory\_offset** – This 45-bit unsigned integer gives the byte address offset of the first byte of the packet start code of the next program stream directory packet. This address offset is relative to the first byte of the start code of the packet which contains this next\_directory\_offset field. The value '0' indicates that there is no next program stream directory packet.

**packet\_stream\_id** – This 8-bit field is the stream\_id of the elementary stream that contains the access unit referenced by this directory entry.

**PES\_header\_position\_offset\_sign** – This 1-bit field is the arithmetic sign for the PES\_header\_position\_offset described immediately following. A value of '0' indicates that the PES\_header\_position\_offset is a positive offset. A value of '1' indicates that the PES\_header\_position\_offset is a negative offset.

**PES\_header\_position\_offset** – This 44-bit unsigned integer gives the byte offset address of the first byte of the PES packet containing the access unit referenced. The offset address is relative to the first byte of the start-code of the packet containing this PES\_header\_position\_offset field. The value '0' indicates that no access unit is referenced.

**reference\_offset** – This 16-bit field is an unsigned integer indicating the position of the first byte of the referenced access unit, measured in bytes relative to the first byte of the PES packet containing the first byte of the referenced access unit.

**PTS (presentation\_time\_stamp)** – This 33-bit field is the PTS of the access unit that is referenced. The semantics of the coding of the PTS field are as described in 2.4.3.6.

**bytes\_to\_read** – This 23-bit unsigned integer is the number of bytes in the program stream after the byte indicated by reference\_offset that are needed to decode the access unit completely. This value includes any bytes multiplexed at the systems layer including those containing information from other streams.

**intra\_coded\_indicator** – This is a 1-bit flag. When set to '1' it indicates that the referenced access unit is not predictively coded. This is independent of other coding parameters that might be needed to decode the access unit. For example, this field shall be coded as '1' for video Intra frames, whereas for 'P' and 'B' frames this bit shall be coded as '0'. For all PES packets containing data which is not from a Rec. ITU-T H.262 | ISO/IEC 13818-2 video stream, this field is undefined (see Table 2-43).

**Table 2-43 – Intra\_coded indicator**

Value	Meaning
'0'	Not Intra
'1'	Intra

**coding\_parameters\_indicator** – This 2-bit field is used to indicate the location of coding parameters that are needed to decode the access units referenced (see Table 2-44). For example, this field can be used to determine the location of quantization matrices for video frames.

**Table 2-44 – Coding parameters indicator**

Value	Meaning
'00'	All coding parameters are set to their default values
'01'	All coding parameters are set in this access unit, at least one of them is not set to a default
'10'	Some coding parameters are set in this access unit
'11'	No coding parameters are coded in this access unit

**packet\_stream\_id\_extension\_msbs** – This 3-bit field is present if packet\_stream\_id equals 0xFD; its coding is specified below.

**packet\_stream\_id\_extension\_lsbs** – This 4-bit field is present if packet\_stream\_id equals 0xFD; its coding is specified below.

If packet\_stream\_id is equal to 0xFD, the packet\_stream\_id\_extension indicates the encoded value of the stream\_id\_extension in the PES header of the PES packet(s) containing the access unit referenced by this directory entry. The value of the packet\_stream\_id\_extension is specified by:

$$\text{packet\_stream\_id\_extension} = \text{packet\_stream\_id\_extension\_msbs} * 16 + \text{packet\_stream\_id\_extension\_lsbs}$$

## 2.6 Program and program element descriptors

Program and program element descriptors are structures which may be used to extend the definitions of programs and program elements. All descriptors have a format which begins with an 8-bit tag value. The tag value is followed by an 8-bit descriptor length and data fields.

### 2.6.1 Semantic definition of fields in program and program element descriptors

The following semantics apply to the descriptors defined in 2.6.2 through the end of 2.6.

**descriptor\_tag** – The descriptor\_tag is an 8-bit field which identifies each descriptor.

Table 2-45 provides the Rec. ITU-T H.222.0 | ISO/IEC 13818-1 defined, Rec. ITU-T H.222.0 | ISO/IEC 13818-1 reserved, and user available descriptor tag values. An 'X' in the TS or PS columns indicates the applicability of the descriptor to either the transport stream or program stream respectively. Note that the meaning of fields in a descriptor may depend on which stream it is used in. Each case is specified in the descriptor semantics below.

**descriptor\_length** – The descriptor\_length is an 8-bit field specifying the number of bytes of the descriptor immediately following descriptor\_length field.

**Table 2-45 – Program and program element descriptors**

descriptor_tag	TS	PS	Identification
0	n/a	n/a	Reserved
1	n/a	X	Forbidden
2	X	X	video_stream_descriptor
3	X	X	audio_stream_descriptor
4	X	X	hierarchy_descriptor
5	X	X	registration_descriptor
6	X	X	data_stream_alignment_descriptor
7	X	X	target_background_grid_descriptor
8	X	X	video_window_descriptor
9	X	X	CA_descriptor
10	X	X	ISO_639_language_descriptor
11	X	X	system_clock_descriptor
12	X	X	multiplex_buffer_utilization_descriptor
13	X	X	copyright_descriptor
14	X		maximum_bitrate_descriptor
15	X	X	private_data_indicator_descriptor
16	X	X	smoothing_buffer_descriptor

Table 2-45 – Program and program element descriptors

descriptor_tag	TS	PS	Identification
17	X		STD_descriptor
18	X	X	IBP_descriptor
19 .. 26	X		Defined in ISO/IEC 13818-6
27	X	X	MPEG-4_video_descriptor
28	X	X	MPEG-4_audio_descriptor
29	X	X	IOD_descriptor
30	X		SL_descriptor
31	X	X	FMC_descriptor
32	X	X	external_ES_ID_descriptor
33	X	X	MuxCode_descriptor
34	X	X	M4MuxBufferSize_descriptor
35	X		multiplexBuffer_descriptor
36	X	X	content_labeling_descriptor
37	X	X	metadata_pointer_descriptor
38	X	X	metadata_descriptor
39	X	X	metadata_STD_descriptor
40	X	X	AVC video descriptor
41	X	X	IPMP_descriptor (defined in ISO/IEC 13818-11, MPEG-2 IPMP)
42	X	X	AVC timing and HRD descriptor
43	X	X	MPEG-2_AAC_audio_descriptor
44	X	X	M4MuxTiming_descriptor
45	X	X	MPEG-4_text_descriptor
46	X	X	MPEG-4_audio_extension_descriptor
47	X	X	Auxiliary_video_stream_descriptor
48	X	X	SVC extension descriptor
49	X	X	MVC extension descriptor
50	X	n/a	J2K video descriptor
51	X	X	MVC operation point descriptor
52	X	X	MPEG2_stereoscopic_video_format_descriptor
53	X	X	Stereoscopic_program_info_descriptor
54	X	X	Stereoscopic_video_info_descriptor
55	X	n/a	Transport_profile_descriptor
56	X	n/a	HEVC video descriptor
57	X	n/a	VVC video descriptor
58	X	n/a	EVC video descriptor
59 .. 62	n/a	n/a	Rec. ITU-T H.222.0   ISO/IEC 13818-1 Reserved
63	X	X	Extension_descriptor
64 .. 255	n/a	n/a	User Private

2.6.2 Video stream descriptor

The video stream descriptor provides basic information which identifies the coding parameters of a video elementary stream as described in Rec. ITU-T H.262 | ISO/IEC 13818-2 or ISO/IEC 11172-2 (see Table 2-46).

Table 2-46 – Video stream descriptor

Syntax	No. of bits	Mnemonic
video_stream_descriptor(){		
<b>descriptor_tag</b>	8	<b>uimsbf</b>
<b>descriptor_length</b>	8	<b>uimsbf</b>
<b>multiple_frame_rate_flag</b>	1	<b>bslbf</b>
<b>frame_rate_code</b>	4	<b>uimsbf</b>
<b>MPEG_1_only_flag</b>	1	<b>bslbf</b>
<b>constrained_parameter_flag</b>	1	<b>bslbf</b>
<b>still_picture_flag</b>	1	<b>bslbf</b>
if (MPEG_1_only_flag == '0'){		
<b>profile_and_level_indication</b>	8	<b>uimsbf</b>
<b>chroma_format</b>	2	<b>uimsbf</b>
<b>frame_rate_extension_flag</b>	1	<b>bslbf</b>
<b>reserved</b>	5	<b>bslbf</b>
}		
}		

### 2.6.3 Semantic definitions of fields in video stream descriptor

**multiple\_frame\_rate\_flag** – This 1-bit field when set to '1' indicates that multiple frame rates may be present in the video stream. When set to a value of '0' only a single frame rate is present.

**frame\_rate\_code** – This is a 4-bit field as defined in 6.3.3 of Rec. ITU-T H.262 | ISO/IEC 13818-2, except that when the **multiple\_frame\_rate\_flag** is set to a value of '1' the indication of a particular frame rate also permits certain other frame rates to be present in the video stream, as specified in Table 2-47:

Table 2-47 – Frame rate code

Coded as	Also includes
23.976	
24.0	23.976
25.0	
29.97	23.976
30.0	23.976 24.0 29.97
50.0	25.0
59.94	23.976 29.97
60.0	23.976 24.0 29.97 30.0 59.94

**MPEG\_1\_only\_flag** – This is a 1-bit field which when set to '1' indicates that the video stream contains only ISO/IEC 11172-2 data. If set to '0' the video stream may contain both Rec. ITU-T H.262 | ISO/IEC 13818-2 video data and constrained parameter ISO/IEC 11172-2 video data.

**constrained\_parameter\_flag** – This is a 1-bit field which when set to '1' indicates that the video stream shall not contain unconstrained ISO/IEC 11172-2 video data. If this field is set to '0' the video stream may contain both constrained parameters and unconstrained ISO/IEC 11172-2 video streams. If the **MPEG\_1\_only\_flag** is set to '0', the **constrained\_parameter\_flag** shall be set to '1'.

**still\_picture\_flag** – This is a 1-bit field, which when set to '1' indicates that the video stream contains only still pictures. If the bit is set to '0' then the video stream may contain either moving or still picture data.

**profile\_and\_level\_indication** – This 8-bit field is coded in the same manner as the **profile\_and\_level\_indication** fields in the Rec. ITU-T H.262 | ISO/IEC 13818-2 video stream. The value of this field indicates a profile and level that is equal to or higher than any profile and level in any sequence in the associated video stream. For the purposes of this subclause, an ISO/IEC 11172-2 constrained parameter stream is considered to be a Main Profile at Low Level stream (MP @ LL).

**chroma\_format** – This 2-bit field is coded in the same manner as the **chroma\_format** fields in the Rec. ITU-T H.262 | ISO/IEC 13818-2 video stream. The value of this field shall be at least equal to or higher than the value of the **chroma\_format** field in any video sequence of the associated video stream. For the purposes of this subclause, an ISO/IEC 11172-2 video stream is considered to have **chroma\_format** field with the value '01', indicating 4:2:0.

**frame\_rate\_extension\_flag** – This is a 1-bit flag which when set to '1' indicates that either or both the `frame_rate_extension_n` and the `frame_rate_extension_d` fields are non-zero in any video sequences of the Rec. ITU-T H.262 | ISO/IEC 13818-2 video stream. For the purposes of this subclause, an ISO/IEC 11172-2 video stream is constrained to have both fields set to zero.

**2.6.4 Audio stream descriptor**

The audio stream descriptor provides basic information which identifies the coding version of an audio elementary stream as described in ISO/IEC 13818-3 or ISO/IEC 11172-3 (see Table 2-48).

**Table 2-48 – Audio stream descriptor**

Syntax	No. of bits	Mnemonic
<code>audio_stream_descriptor(){</code>		
<b>descriptor_tag</b>	8	<b>uimsbf</b>
<b>descriptor_length</b>	8	<b>uimsbf</b>
<b>free_format_flag</b>	1	<b>bslbf</b>
<b>ID</b>	1	<b>bslbf</b>
<b>layer</b>	2	<b>bslbf</b>
<b>variable_rate_audio_indicator</b>	1	<b>bslbf</b>
<b>reserved</b>	3	<b>bslbf</b>
<code>}</code>		

**2.6.5 Semantic definition of fields in audio stream descriptor**

**free\_format\_flag** – This 1-bit field when set to '1' indicates that the audio stream may contain one or more audio frames with the `bitrate_index` set to '0000'. If set to '0', then the `bitrate_index` is not '0000' (refer to 2.4.2.3 of ISO/IEC 13818-3) in any audio frame of the audio stream.

**ID** – This 1-bit field when set to '1' indicates that the ID field is set to '1' in each audio frame in the audio stream (refer to 2.4.2.3 of ISO/IEC 13818-3).

**layer** – This 2-bit field is coded in the same manner as the `layer` field in the ISO/IEC 13818-3 or ISO/IEC 11172-3 audio streams (refer to 2.4.2.3 of ISO/IEC 13818-3). The layer indicated in this field shall be equal to or higher than the highest layer specified in any audio frame of the audio stream.

**variable\_rate\_audio\_indicator** – This 1-bit flag, when set to '0' indicates that the encoded value of the bit rate field shall not change in consecutive audio frames which are intended to be presented without discontinuity.

**2.6.6 Hierarchy descriptor**

The hierarchy descriptor provides information to identify the program elements containing components of hierarchically-coded video, audio, and private streams. (See Table 2-49.)

**Table 2-49 – Hierarchy descriptor**

Syntax	No. of bits	Mnemonic
<code>hierarchy_descriptor() {</code>		
<b>descriptor_tag</b>	8	<b>uimsbf</b>
<b>descriptor_length</b>	8	<b>uimsbf</b>
<b>no_view_scalability_flag</b>	1	<b>bslbf</b>
<b>no_temporal_scalability_flag</b>	1	<b>bslbf</b>
<b>no_spatial_scalability_flag</b>	1	<b>bslbf</b>
<b>no_quality_scalability_flag</b>	1	<b>bslbf</b>
<b>hierarchy_type</b>	4	<b>uimsbf</b>
<b>reserved</b>	2	<b>bslbf</b>
<b>hierarchy_layer_index</b>	6	<b>uimsbf</b>
<b>tref_present_flag</b>	1	<b>bslbf</b>
<b>reserved</b>	1	<b>bslbf</b>
<b>hierarchy_embedded_layer_index</b>	6	<b>uimsbf</b>

Table 2-49 – Hierarchy descriptor

Syntax	No. of bits	Mnemonic
<b>reserved</b>	<b>2</b>	<b>bslbf</b>
<b>hierarchy_channel</b>	<b>6</b>	<b>uimsbf</b>
}		

### 2.6.7 Semantic definition of fields in hierarchy descriptor

**no\_view\_scalability\_flag** – A 1-bit flag, which when set to '0' indicates that the associated program element enhances the number of views of the bit-stream resulting from the program element referenced by the `hierarchy_embedded_layer_index`. The value of '1' for this flag is reserved.

**no\_temporal\_scalability\_flag** – A 1-bit flag, which when set to '0' indicates that the associated program element enhances the frame rate of the bit-stream resulting from the program element referenced by the `hierarchy_embedded_layer_index`. The value of '1' for this flag is reserved.

**no\_spatial\_scalability\_flag** – A 1-bit flag, which when set to '0' indicates that the associated program element enhances the spatial resolution of the bit-stream resulting from the program element referenced by the `hierarchy_embedded_layer_index`. The value of '1' for this flag is reserved.

**no\_quality\_scalability\_flag** – A 1-bit flag, which when set to '0' indicates that the associated program element enhances the SNR quality or fidelity of the bit-stream resulting from the program element referenced by the `hierarchy_embedded_layer_index`. The value of '1' for this flag is reserved.

**hierarchy\_type** – The hierarchical relation between the associated hierarchy layer and its hierarchy embedded layer is defined in Table 2-50. If scalability applies in more than one dimension, this field shall be set to the value of '8' ("Combined Scalability"), and the flags `no_view_scalability_flag`, `no_temporal_scalability_flag`, `no_spatial_scalability_flag` and `no_quality_scalability_flag` shall be set accordingly. For MVC video sub-bitstreams, this field shall be set to the value of '9' ("MVC video sub-bitstream") and the flags `no_view_scalability_flag`, `no_temporal_scalability_flag`, `no_spatial_scalability_flag` and `no_quality_scalability_flag` shall be set to '1'. For MVC base view sub-bitstreams, this field shall be set to the value of '15' and the flags `no_view_scalability_flag`, `no_temporal_scalability_flag`, `no_spatial_scalability_flag` and `no_quality_scalability_flag` shall be set to '1'. For MVCD video sub-bitstreams, this field shall be set to the value of '9' ("MVCD video sub-bitstream") and the flags `no_view_scalability_flag`, `no_temporal_scalability_flag`, `no_spatial_scalability_flag` and `no_quality_scalability_flag` shall be set to '1'. For MVCD base view sub-bitstreams, this field shall be set to the value of '15' and the flags `no_view_scalability_flag`, `no_temporal_scalability_flag`, `no_spatial_scalability_flag` and `no_quality_scalability_flag` shall be set to '1'.

**hierarchy\_layer\_index** – The `hierarchy_layer_index` is a 6-bit field that defines a unique index of the associated program element in a table of coding layer hierarchies. Indices shall be unique within a single program definition. For video sub-bitstreams of AVC video streams conforming to one or more profiles defined in Annex G of Rec. ITU-T H.264 | ISO/IEC 14496-10, this is the program element index, which is assigned in a way that the bitstream order will be correct if associated SVC dependency representations of the video sub-bitstreams of the same access unit are re-assembled in increasing order of `hierarchy_layer_index`. For MVC video sub-bitstreams of AVC video streams conforming to one or more profiles defined in Annex H of Rec. ITU-T H.264 | ISO/IEC 14496-10, this is the program element index, which is assigned in a way that the bitstream order will be correct if associated MVC view-component subsets of the MVC video sub-bitstreams of the same access unit are re-assembled in increasing order of `hierarchy_layer_index`. For MVCD video sub-bitstreams of AVC video streams conforming to one or more profiles defined in Annex I of Rec. ITU-T H.264 | ISO/IEC 14496-10, this is the program element index, which is assigned in a way that the bitstream order will be correct if associated MVCD view-component subsets of the MVCD video sub-bitstreams of the same access unit are re-assembled in increasing order of `hierarchy_layer_index`.

**tref\_present\_flag** – A 1-bit flag, which when set to '0' indicates that the TREF field may be present in the PES packet headers in the associated elementary stream. The value of '1' for this flag is reserved.

**hierarchy\_embedded\_layer\_index** – The `hierarchy_embedded_layer_index` is a 6-bit field that defines the `hierarchy_layer_index` of the program element that needs to be accessed and be present in decoding order before decoding of the elementary stream associated with this `hierarchy_descriptor`. This field is undefined if the `hierarchy_type` value is 15.

**hierarchy\_channel** – The `hierarchy_channel` is a 6-bit field that indicates the intended channel number for the associated program element in an ordered set of transmission channels. The most robust transmission channel is defined by the lowest value of this field with respect to the overall transmission hierarchy definition.

NOTE – A given hierarchy\_channel may at the same time be assigned to several program elements.

**Table 2-50 – Hierarchy\_type field values**

Value	Description
0	Reserved
1	Spatial Scalability
2	SNR Scalability
3	Temporal Scalability
4	Data partitioning
5	Extension bitstream
6	Private Stream
7	Multi-view Profile
8	Combined Scalability or MV-HEVC sub-partition.
9	MVC video sub-bitstream or MVCD video sub-bitstream
10	Auxiliary picture layer as defined in Annex F of Rec. ITU-T H.265   ISO/IEC 23008-2.
11 .. 14	Reserved
15	Base layer or MVC base view sub-bitstream or AVC video sub-bitstream of MVC or HEVC temporal video sub-bitstream or HEVC base sub-partition or Base layer of MVCD base view sub-bitstream or AVC video sub-bitstream of MVCD or VVC temporal video sub-bitstream or EVC temporal video sub-bitstream.

**2.6.8 Registration descriptor**

The registration\_descriptor provides a method to uniquely and unambiguously identify formats of private data (see Table 2-51).

**Table 2-51 – Registration descriptor**

Syntax	No. of bits	Identifier
<pre> registration_descriptor() {     descriptor_tag     descriptor_length     format_identifier     for (i = 0; i &lt; N; i++){         additional_identification_info     } }                     </pre>	<p>8</p> <p>8</p> <p>32</p> <p>8</p>	<p>uimsbf</p> <p>uimsbf</p> <p>uimsbf</p> <p>bslbf</p>

**2.6.9 Semantic definition of fields in registration descriptor**

**format\_identifier** – The format\_identifier is a 32-bit value obtained from a Registration Authority as designated by ISO/IEC JTC 1/SC 29.

**additional\_identification\_info** – The meaning of additional\_identification\_info bytes, if any, are defined by the assignee of that format\_identifier, and once defined they shall not change.

**2.6.10 Data stream alignment descriptor**

The data stream alignment descriptor describes which type of alignment is present in the associated elementary stream. If the data\_alignment\_indicator in the PES packet header is set to '1' and the descriptor is present, alignment – as specified in this descriptor – is required (see Table 2-52).

Table 2-52 – Data stream alignment descriptor

Syntax	No. of bits	Mnemonic
data_stream_alignment_descriptor() { <b>descriptor_tag</b> <b>descriptor_length</b> <b>alignment_type</b> }	8 8 8	<b>uimsbf</b> <b>uimsbf</b> <b>uimsbf</b>

### 2.6.11 Semantics of fields in data stream alignment descriptor

**alignment\_type** – Table 2-53 describes the alignment type for ISO/IEC 11172-2 video, Rec. ITU-T H.262 | ISO/IEC 13818-2 video, or ISO/IEC 14496-2 visual streams when the data\_alignment\_indicator in the PES packet header has a value of '1'. For these video streams, the first PES\_packet\_data\_byte following the PES header shall be the first byte of a start code of the type indicated in Table 2-53. At the beginning of a video sequence, the alignment shall occur at the start code of the first sequence header.

NOTE – Specifying alignment type '1' from Table 2-53 does not preclude the alignment from beginning at a GOP or SEQ header.

The definition of an access unit is given in 2.1.1.

Table 2-53 – Video stream alignment values

Alignment type	Description
0	Reserved
1	Slice, or video access unit
2	Video access unit
3	GOP, or SEQ
4	SEQ
5 .. 255	Reserved

Table 2-54 describes the alignment type for Rec. ITU-T H.264 | ISO/IEC 14496-10 video when the data\_alignment\_indicator in the PES packet header has a value of '1'.

In this case:

- For AVC video streams conforming to one or more profiles defined in Annex A of Rec. ITU-T H.264 | ISO/IEC 14496-10, the first PES\_packet\_data\_byte following the PES header shall be the first byte of an AVC access unit or the first byte of an AVC slice, as signalled by the alignment\_type value.
- For video sub-bitstreams of AVC video streams conforming to one or more profiles defined in Annex G of Rec. ITU-T H.264 | ISO/IEC 14496-10, the first PES\_packet\_data\_byte following the PES header shall be the first byte of an SVC dependency representation or the first byte of an SVC slice, as signalled by the alignment\_type value.
- For MVC video sub-bitstreams of AVC video streams conforming to one or more profiles defined in Annex H of Rec. ITU-T H.264 | ISO/IEC 14496-10, the first PES\_packet\_data\_byte following the PES header shall be the first byte of an MVC view-component subset or the first byte of an MVC slice, as signalled by the alignment\_type value.
- For MVCD video sub-bitstreams of AVC video streams conforming to one or more profiles defined in Annex I of Rec. ITU-T H.264 | ISO/IEC 14496-10, the first PES\_packet\_data\_byte following the PES header shall be the first byte of an MVCD view-component subset, the first byte of an MVC slice or the first byte of MVCD slice, as signalled by the alignment\_type value.

**Table 2-54 – AVC video stream alignment values**

Alignment type	Description
0	Reserved
1	AVC slice or AVC access unit
2	AVC access unit
3	SVC slice or SVC dependency representation
4	SVC dependency representation
5	MVC slice or MVC view-component subset
6	MVC view-component subset
7	MVCD slice or MVCD view-component subset
8	MVCD view-component subset
9 .. 255	Reserved

Table 2-55 describes the alignment type for HEVC when the data\_alignment\_indicator in the PES packet header has a value of '1'.

**Table 2-55 – HEVC video stream alignment values**

Alignment type	Description
0	Reserved
1	HEVC access unit
2	HEVC slice
3	HEVC access unit or slice
4	HEVC tile of slices
5	HEVC access unit or tile of slices
6	HEVC slice or tile of slices
7	HEVC access unit or slice or tile of slices
8	HEVC slice segment
9	HEVC slice segment or access unit
10	HEVC slice segment or slice
11	HEVC slice segment or access unit or slice
12	HEVC slice segment or tile of slices
13	HEVC slice segment or access unit or tile of slices
14	HEVC slice segment or slice or tile of slices
15	HEVC slice segment or access unit or slice or tile of slices
16 .. 255	Reserved

Table 2-56 describes the audio alignment type when the data\_alignment\_indicator in the PES packet header has a value of '1'. In this case the first PES\_packet\_data\_byte following the PES header is the first byte of an audio sync word.

**Table 2-56 – Audio stream alignment values**

Alignment type	Description
0	Reserved
1	Sync word
2 .. 255	Reserved

Table 2-57 describes the alignment type for VVC when the data\_alignment\_indicator in the PES packet header has a value of '1'.

Table 2-57 – VVC video stream alignment values

Alignment type	Description
00	Reserved
01	VVC access unit
02	VVC slice
03	VVC access unit or slice
04	VVC tile of slices
05	VVC access unit or tile of slices
06	VVC slice or tile of slices
07	VVC access unit or slice or tile of slices
08	VVC subpicture
09	VVC access unit or subpicture
10	VVC slice or subpicture
11	VVC subpicture or tile of slices
12	VVC access unit or slice or subpicture
13	VVC access unit or subpicture or tile of slices
14	VVC slice or subpicture or tile of slices
15	VVC access unit or slice or subpicture or tile of slices
16-255	Reserved

Table 2-58 describes the alignment type for EVC when the data\_alignment\_indicator in the PES packet header has a value of '1'.

Table 2-58 – EVC video stream alignment values

Alignment type	Description
00	Reserved
01	EVC access unit
02	EVC slice
03	EVC access unit or slice
04-255	Reserved

### 2.6.12 Target background grid descriptor

It is possible to have one or more video streams which, when decoded, are not intended to occupy the full display area (e.g., a monitor). The combination of target\_background\_grid\_descriptor and video\_window\_descriptors allows the display of these video windows in their desired locations. The target\_background\_grid\_descriptor is used to describe a grid of unit pixels projected on to the display area. The video\_window\_descriptor is then used to describe, for the associated stream, the location on the grid at which the top left pixel of the display window or display rectangle of the video presentation unit should be displayed. This is represented in Figure 2-3.

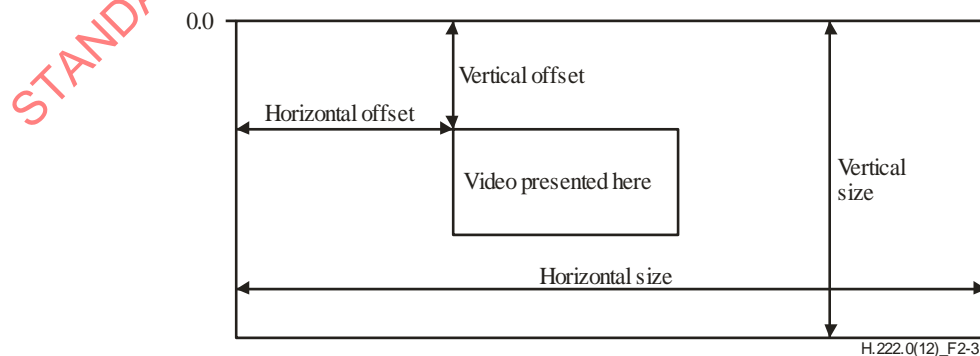

Figure 2-3 – Target background grid descriptor display area

**2.6.13 Semantics of fields in target background grid descriptor**

**horizontal\_size** – The horizontal size of the target background grid in pixels.

**vertical\_size** – The vertical size of the target background grid in pixels.

**aspect\_ratio\_information** – Specifies the sample aspect ratio or display aspect ratio of the target background grid. Aspect\_ratio\_information is defined in Rec. ITU-T H.262 | ISO/IEC 13818-2 (see Table 2-59).

**Table 2-59 – Target background grid descriptor**

Syntax	No. of bits	Mnemonic
target_background_grid_descriptor() {		
<b>descriptor_tag</b>	<b>8</b>	<b>uimsbf</b>
<b>descriptor_length</b>	<b>8</b>	<b>uimsbf</b>
<b>horizontal_size</b>	<b>14</b>	<b>uimsbf</b>
<b>vertical_size</b>	<b>14</b>	<b>uimsbf</b>
<b>aspect_ratio_information</b>	<b>4</b>	<b>uimsbf</b>
}		

**2.6.14 Video window descriptor**

The video window descriptor (see Table 2-60) is used to describe the window characteristics of the associated video elementary stream. Its values reference the target background grid descriptor for the same stream. Also see target\_background\_grid\_descriptor in 2.6.12.

**Table 2-60 – Video window descriptor**

Syntax	No. of bits	Mnemonic
video_window_descriptor() {		
<b>descriptor_tag</b>	<b>8</b>	<b>uimsbf</b>
<b>descriptor_length</b>	<b>8</b>	<b>uimsbf</b>
<b>horizontal_offset</b>	<b>14</b>	<b>uimsbf</b>
<b>vertical_offset</b>	<b>14</b>	<b>uimsbf</b>
<b>window_priority</b>	<b>4</b>	<b>uimsbf</b>
}		

**2.6.15 Semantic definition of fields in video window descriptor**

**horizontal\_offset** – The value indicates the horizontal position of the top left pixel of the current video display window or display rectangle if indicated in the picture display extension on the target background grid for display as defined in the target\_background\_grid\_descriptor. The top left pixel of the video window shall be one of the pixels of the target background grid (refer to Figure 2-3).

**vertical\_offset** – The value indicates the vertical position of the top left pixel of the current video display window or display rectangle if indicated in the picture display extension on the target background grid for display as defined in the target\_background\_grid\_descriptor. The top left pixel of the video window shall be one of the pixels of the target background grid (refer to Figure 2-3).

**window\_priority** – The value indicates how windows overlap. A value of 0 being lowest priority and a value of 15 is the highest priority, i.e., windows with priority 15 are always visible.

**2.6.16 Conditional access descriptor**

The conditional access descriptor is used to specify both system-wide conditional access management information such as EMMs and elementary stream-specific information such as ECMs. It may be used in both the TS\_program\_map\_section (refer to 2.4.4.9) and the program\_stream\_map (refer to 2.5.3). If any elementary stream is scrambled, a CA descriptor shall be present for the program containing that elementary stream. If any system-wide conditional access management information exists within a transport stream, a CA descriptor shall be present in the conditional access table.

When the CA descriptor is found in the TS\_program\_map\_section (table\_id = 0x02), the CA\_PID points to packets containing program related access control information, such as ECMs. Its presence as program information indicates

applicability to the entire program. In the same case, its presence as extended ES information indicates applicability to the associated program element. Provision is also made for private data.

When the CA descriptor is found in the CA\_section (table\_id = 0x01), the CA\_PID points to packets containing system-wide and/or access control management information, such as EMMs.

The contents of the transport stream packets containing conditional access information are privately defined (see Table 2-61).

**Table 2-61 – Conditional access descriptor**

Syntax	No. of bits	Mnemonic
CA_descriptor() {		
<b>descriptor_tag</b>	<b>8</b>	<b>uimsbf</b>
<b>descriptor_length</b>	<b>8</b>	<b>uimsbf</b>
<b>CA_system_ID</b>	<b>16</b>	<b>uimsbf</b>
<b>reserved</b>	<b>3</b>	<b>bslbf</b>
<b>CA_PID</b>	<b>13</b>	<b>uimsbf</b>
for (i = 0; i < N; i++) {		
<b>private_data_byte</b>	<b>8</b>	<b>uimsbf</b>
}		
}		

#### 2.6.17 Semantic definition of fields in conditional access descriptor

**CA\_system\_ID** – This is a 16-bit field indicating the type of CA system applicable for either the associated ECM and/or EMM streams. The coding of this is privately defined and is not specified by ITU-T | ISO/IEC.

**CA\_PID** – This is a 13-bit field indicating the PID of the transport stream packets which shall contain either ECM or EMM information for the CA systems as specified with the associated CA\_system\_ID. The contents (ECM or EMM) of the packets indicated by the CA\_PID is determined from the context in which the CA\_PID is found, i.e., a TS\_program\_map\_section or the CA table in the transport stream, or the stream\_id field in the program stream.

In transport streams, the presence of PID 0x03 indicates that there is IPMP as described in ISO/IEC 13818-11 used by components in the transport stream. In program streams, the presence of stream\_ID\_extension value 0x00 indicates that IPMP as described in ISO/IEC 13818-11 is used by components in the program stream. Within a given Rec. ITU-T H.222.0 | ISO/IEC 13818-1 stream, components could use both IPMP as described in ISO/IEC 13818-11 as well as CA as defined in ISO/IEC 13818-1:2006. Compatibility between the two schemes is described in ISO/IEC 13818-11.

#### 2.6.18 ISO 639 language descriptor

The language descriptor is used to specify the language of the associated program element (see Table 2-62).

**Table 2-62 – ISO 639 language descriptor**

Syntax	No. of bits	Mnemonic
ISO_639_language_descriptor() {		
<b>descriptor_tag</b>	<b>8</b>	<b>uimsbf</b>
<b>descriptor_length</b>	<b>8</b>	<b>uimsbf</b>
for (i = 0; i < N; i++) {		
<b>ISO_639_language_code</b>	<b>24</b>	<b>bslbf</b>
<b>audio_type</b>	<b>8</b>	<b>bslbf</b>
}		
}		

#### 2.6.19 Semantic definition of fields in ISO 639 language descriptor

**ISO\_639\_language\_code** – Identifies the language or languages used by the associated program element. The ISO\_639\_language\_code contains a 3-character code as specified by ISO 639, Part 2. Each character is coded into 8 bits

according to ISO 8859-1 and inserted in order into this 24-bit field. In the case of multilingual audio streams the sequence of ISO\_639\_language\_code fields shall reflect the content of the audio stream.

**audio\_type** – The audio\_type is an 8-bit field which specifies the type of stream defined in Table 2-63. This field is used to address complete main elementary streams. If multiple substreams exists, then audio\_type shall define the group of subcomponents. Any further detail of specific subcomponents is left up to in-stream information.

Multiple ISO\_639\_language\_code / audio\_type pairs can be described within a single ISO 639 language descriptor.

NOTE – An example of this would be an english track that is suitable for both Hearing-impaired in English with Visual impaired commentary in Spanish. i=0{“ENG”/0x02} and i=1{“ESP”/0x03}.

**Table 2-63 – Audio type values**

Value	Description
0x00	Undefined <sup>a</sup>
0x01	Clean effects <sup>b</sup>
0x02	Hearing impaired <sup>c</sup>
0x03	Visual impaired commentary <sup>d</sup>
0x04 .. 0x7F	User Private
0x80	Primary <sup>e</sup>
0x81	Native <sup>f</sup>
0x82	Emergency <sup>g</sup>
0x83	Primary commentary <sup>h</sup>
0x84	Alternate commentary <sup>i</sup>
0x85 .. 0xFF	Reserved

<sup>a</sup> Undefined: This is a default value which indicates the purpose of the stream is unknown. It is different from the languages code “und” which would indicate the language of the audio is unknown.

<sup>b</sup> Clean effects: This value indicates that the referenced program element has no language.

<sup>c</sup> Hearing impaired: This value indicates that the referenced program element is prepared for the hearing impaired. An alternate label for this is enhanced audio intelligibility.

<sup>d</sup> Visual\_impaired\_commentary: This value indicates that the referenced program element is prepared for the visually impaired viewer. Alternate labels for this are audio descriptive services (ADS) or descriptive video services (DVS).

<sup>e</sup> Primary: This value indicates the default recommended language of the program. This is a separate value from the language code itself. If the language code is Welsh with and Undefined audio\_type, it means “this is Welsh”. When the language code is welsh with audio\_type 0x80, it means “this is Welsh”, and it is the primary language of this program.”

<sup>f</sup> Native: This value indicates the language in which the program was produced. An absence of this value indicates that it is either undefined or a dubbed language.

<sup>g</sup> Emergency: This value indicates the purpose for the stream is used for emergency event information.

<sup>h</sup> Primary commentary: This value indicates the referenced program element is prepared with narration in addition to the natural sound of the content. For example, this narration may be an announcer to a sporting event or director’s comments of a film or program and is the default commentary for the content.

<sup>i</sup> Alternate commentary: This value indicates the referenced program element is prepared with alternate narration in addition to the natural sound of the content. This additional commentary is of the same language as the primary commentary and may be used for example in cases such as an additional away announcer to a sporting event or producer’s comments of the film or program.

**2.6.20 System clock descriptor**

This descriptor conveys information about the system clock that was used to generate the timestamps.

If an external clock reference was used, the external\_clock\_reference\_indicator may be set to '1'. The decoder optionally may use the same external reference if it is available.

If the system clock is more accurate than the 30-ppm accuracy required, then the accuracy of the clock can be communicated by encoding it in the clock\_accuracy fields. The clock frequency accuracy is:

$$\text{clock\_accuracy\_integer} \times 10^{-\text{clock\_accuracy\_exponent}} \text{ ppm} \quad (2-26)$$

If `clock_accuracy_integer` is set to '0', then the system clock accuracy is 30 ppm. When the `external_clock_reference_indicator` is set to '1', the clock accuracy pertains to the external reference clock (see Table 2-64).

Table 2-64 – System clock descriptor

Syntax	No. of bits	Mnemonic
<code>system_clock_descriptor() {</code>		
<b>descriptor_tag</b>	8	<b>uimsbf</b>
<b>descriptor_length</b>	8	<b>uimsbf</b>
<b>external_clock_reference_indicator</b>	1	<b>bslbf</b>
<b>reserved</b>	1	<b>bslbf</b>
<b>clock_accuracy_integer</b>	6	<b>uimsbf</b>
<b>clock_accuracy_exponent</b>	3	<b>uimsbf</b>
<b>reserved</b>	5	<b>bslbf</b>
<code>}</code>		

### 2.6.21 Semantic definition of fields in system clock descriptor

**external\_clock\_reference\_indicator** – This is a 1-bit indicator. When set to '1', it indicates that the system clock has been derived from an external frequency reference that may be available at the decoder.

**clock\_accuracy\_integer** – This is a 6-bit integer. Together with the `clock_accuracy_exponent`, it gives the fractional frequency accuracy of the system clock in parts per million.

**clock\_accuracy\_exponent** – This is a 3-bit integer. Together with the `clock_accuracy_integer`, it gives the fractional frequency accuracy of the system clock in parts per million.

### 2.6.22 Multiplex buffer utilization descriptor

The multiplex buffer utilization descriptor provides bounds on the occupancy of the STD multiplex buffer. This information is intended for devices such as remultiplexers, which may use this information to support a desired re-multiplexing strategy (see Table 2-65).

Table 2-65 – Multiplex buffer utilization descriptor

Syntax	No. of bits	Mnemonic
<code>Multiplex_buffer_utilization_descriptor() {</code>		
<b>descriptor_tag</b>	8	<b>uimsbf</b>
<b>descriptor_length</b>	8	<b>uimsbf</b>
<b>bound_valid_flag</b>	1	<b>bslbf</b>
<b>LTW_offset_lower_bound</b>	15	<b>uimsbf</b>
<b>reserved</b>	1	<b>bslbf</b>
<b>LTW_offset_upper_bound</b>	15	<b>uimsbf</b>
<code>}</code>		

### 2.6.23 Semantic definition of fields in multiplex buffer utilization descriptor

**bound\_valid\_flag** – A value of '1' indicates that the `LTW_offset_lower_bound` and the `LTW_offset_upper_bound` fields are valid.

**LTW\_offset\_lower\_bound** – This 15-bit field is defined only if the `bound_valid` flag has a value of '1'. When defined, this field has the units of (27 MHz/300) clock periods, as defined for the `LTW_offset` (refer to 2.4.3.4). The `LTW_offset_lower_bound` represents the lowest value that any `LTW_offset` field would have, if that field were coded in every packet of the stream or streams referenced by this descriptor. Actual `LTW_offset` fields may or may not be coded in the bitstream when the multiplex buffer utilization descriptor is present. This bound is valid until the next occurrence of this descriptor.

**LTW\_offset\_upper\_bound** – This 15-bit field is defined only if the bound\_valid has a value of '1'. When defined, this field has the units of (27 MHz/300) clock periods, as defined for the LTW\_offset (refer to 2.4.3.4). The LTW\_offset\_upper\_bound represents the largest value that any LTW\_offset field would have, if that field were coded in every packet of the stream or streams referenced by this descriptor. Actual LTW\_offset fields may or may not be coded in the bitstream when the multiplex buffer utilization descriptor is present. This bound is valid until the next occurrence of this descriptor.

**2.6.24 Copyright descriptor**

The copyright\_descriptor provides a method to enable audiovisual works identification. This copyright\_descriptor applies to programs or program elements within programs (see Table 2-66).

**Table 2-66 – Copyright descriptor**

Syntax	No. of bits	Identifier
copyright_descriptor() {		
<b>descriptor_tag</b>	<b>8</b>	<b>uimsbf</b>
<b>descriptor_length</b>	<b>8</b>	<b>uimsbf</b>
<b>copyright_identifier</b>	<b>32</b>	<b>uimsbf</b>
for (i = 0; i < N; i++){		
<b>additional_copyright_info</b>	<b>8</b>	<b>bslbf</b>
}		
}		

**2.6.25 Semantic definition of fields in copyright descriptor**

**copyright\_identifier** – This field is a 32-bit value obtained from the Registration Authority.

**additional\_copyright\_info** – The meaning of additional\_copyright\_info bytes, if any, are defined by the assignee of that copyright\_identifier, and once defined, they shall not change.

**2.6.26 Maximum bitrate descriptor**

See Table 2-67.

**Table 2-67 – Maximum bitrate descriptor**

Syntax	No. of bits	Identifier
maximum_bitrate_descriptor() {		
<b>descriptor_tag</b>	<b>8</b>	<b>uimsbf</b>
<b>descriptor_length</b>	<b>8</b>	<b>uimsbf</b>
<b>reserved</b>	<b>2</b>	<b>bslbf</b>
<b>maximum_bitrate</b>	<b>22</b>	<b>uimsbf</b>
}		

**2.6.27 Semantic definition of fields in maximum bitrate descriptor**

**maximum\_bitrate** – The maximum bitrate is coded as a 22-bit positive integer in this field. The value indicates an upper bound of the bitrate, including transport overhead, that will be encountered in this program element or program. The value of maximum\_bitrate is expressed in units of 50 bytes/second. The maximum\_bitrate\_descriptor is included in the Program Map Table (PMT). Its presence as extended program information indicates applicability to the entire program. Its presence as ES information indicates applicability to the associated program element.

## 2.6.28 Private data indicator descriptor

See Table 2-68.

**Table 2-68 – Private data indicator descriptor**

Syntax	No. of bits	Identifier
private_data_indicator_descriptor() {		
<b>descriptor_tag</b>	<b>8</b>	<b>uimsbf</b>
<b>descriptor_length</b>	<b>8</b>	<b>uimsbf</b>
<b>private_data_indicator</b>	<b>32</b>	<b>uimsbf</b>
}		

## 2.6.29 Semantic definition of fields in Private data indicator descriptor

**private\_data\_indicator** – The value of the private\_data\_indicator is private and shall not be defined by ITU-T | ISO/IEC.

## 2.6.30 Smoothing buffer descriptor

This descriptor is optional and conveys information about the size of a smoothing buffer,  $SB_n$ , associated with this descriptor, and the associated leak rate out of that buffer, for the program element(s) that it refers to.

In the case of transport streams, bytes of transport stream packets of the associated program element(s) present in the transport stream are input to a buffer  $SB_n$  of size given by sb\_size, at the time defined by equation 2-4.

In the case of program streams, bytes of all PES packets of the associated elementary streams, are input to a buffer  $SB_n$  of size given by sb\_size, at the time defined by equation 2-21.

When there is data present in this buffer, bytes are removed from this buffer at a rate defined by sb\_leak\_rate. The buffer,  $SB_n$  shall never overflow. During the continuous existence of a program, the value of the elements of the Smoothing Buffer descriptor of the different program element(s) in the program, shall not change.

The meaning of the smoothing buffer\_descriptor (see Table 2-69) is only defined when it is included in the PMT or the program stream Map.

If, in the case of a transport stream, it is present in the ES info in the Program Map Table, all transport stream packets of the PID of that program element enter the smoothing buffer.

If, in the case of a transport stream, it is present in the program information, the following transport stream packets enter the smoothing buffer:

- all transport stream packets of all PIDs listed as elementary\_PIDs in the extended program information as well as;
- all transport stream packets of the PID which is equal to the PMT\_PID of this section;
- all transport stream packets of the PCR\_PID of the program.

All bytes that enter the associated buffer also exit it.

At any given time there shall be at most one descriptor referring to any individual program element and at most one descriptor referring to the program in its entirety.

**Table 2-69 – Smoothing buffer descriptor**

Syntax	No. of bits	Mnemonic
smoothing_buffer_descriptor () {		
<b>descriptor_tag</b>	<b>8</b>	<b>uimsbf</b>
<b>descriptor_length</b>	<b>8</b>	<b>uimsbf</b>
<b>reserved</b>	<b>2</b>	<b>bslbf</b>
<b>sb_leak_rate</b>	<b>22</b>	<b>uimsbf</b>
<b>reserved</b>	<b>2</b>	<b>bslbf</b>
<b>sb_size</b>	<b>22</b>	<b>uimsbf</b>
}		

**2.6.31 Semantic definition of fields in smoothing buffer descriptor**

**sb\_leak\_rate** – This 22-bit field is coded as a positive integer. Its contents indicate the value of the leak rate out of the  $SB_n$  buffer for the associated elementary stream or other data in units of 400 bits/s.

**sb\_size** – This 22-bit field is coded as a positive integer. Its contents indicate the value of the size of the multiplexing buffer smoothing buffer  $SB_n$  for the associated elementary stream or other data in units of 1 byte (see Table 2-68).

**2.6.32 STD descriptor**

This descriptor is optional and applies only to the T-STD model and to Rec. ITU-T H.262 | ISO/IEC 13818-2 video elementary streams, and is used as specified in 2.4.2. This descriptor does not apply to program streams (see Table 2-70).

**Table 2-70 – STD descriptor**

Syntax	No. of bits	Mnemonic
STD_descriptor () {		
<b>descriptor_tag</b>	<b>8</b>	<b>uimsbf</b>
<b>descriptor_length</b>	<b>8</b>	<b>uimsbf</b>
<b>reserved</b>	<b>7</b>	<b>bslbf</b>
<b>leak_valid_flag</b>	<b>1</b>	<b>bslbf</b>
}		

**2.6.33 Semantic definition of fields in STD descriptor**

**leak\_valid\_flag** – The leak\_valid\_flag is a 1-bit flag. When set to '1', the transfer of data from the buffer  $MB_n$  to the buffer  $EB_n$  in the T-STD uses the leak method as defined in 2.4.2.4. If this flag has a value equal to '0', and the vbv\_delay fields present in the associated video stream do not have the value 0xFFFF, the transfer of data from the buffer  $MB_n$  to the buffer  $EB_n$  uses the vbv\_delay method as defined in 2.4.2.4.

**2.6.34 IBP descriptor**

This optional descriptor provides information about some characteristics of the sequence of frame types in an ISO/IEC 11172-2, Rec. ITU-T H.262 | ISO/IEC 13818-2, or ISO/IEC 14496-2 video stream (see Table 2-71).

**Table 2-71 – IBP descriptor**

Syntax	No. of bits	Mnemonic
ibp_descriptor() {		
<b>descriptor_tag</b>	<b>8</b>	<b>uimsbf</b>
<b>descriptor_length</b>	<b>8</b>	<b>uimsbf</b>
<b>closed_gop_flag</b>	<b>1</b>	<b>uimsbf</b>
<b>identical_gop_flag</b>	<b>1</b>	<b>uimsbf</b>
<b>max_gop_length</b>	<b>14</b>	<b>uimsbf</b>
}		

**2.6.35 Semantic definition of fields in IBP descriptor**

**closed\_gop\_flag** – This 1-bit flag when set to '1' indicates that a group of pictures header is encoded before every I-frame and that the closed\_gop flag is set to '1' in all group of pictures headers in the video sequence.

**identical\_gop\_flag** – This 1-bit flag when set to '1' indicates that the number of P-frames and B-frames between I-frames, and the picture coding types and sequence of picture types between I-pictures is the same throughout the sequence, except possibly for the pictures up to the second I-picture.

**max\_gop\_length** – This 14-bit unsigned integer indicates the maximum number of the coded pictures between any two consecutive I-pictures in the sequence. The value of '0' is forbidden.

### 2.6.36 MPEG-4 video descriptor

For individual ISO/IEC 14496-2 streams directly carried in PES packets, as defined in 2.11.2, the MPEG-4 video descriptor (see Table 2-72) provides basic information for identifying the coding parameters of such visual elementary streams. The MPEG-4 video descriptor does not apply to ISO/IEC 14496-2 streams encapsulated in SL-packets and in M4Mux packets, as defined in 2.11.3.

**Table 2-72 – MPEG-4 video descriptor**

Syntax	No. of bits	Mnemonic
MPEG-4_video_descriptor () {		
<b>descriptor_tag</b>	<b>8</b>	<b>uimsbf</b>
<b>descriptor_length</b>	<b>8</b>	<b>uimsbf</b>
<b>MPEG-4_visual_profile_and_level</b>	<b>8</b>	<b>uimsbf</b>
}		

### 2.6.37 Semantic definition of fields in MPEG-4 video descriptor

**MPEG-4\_video\_profile\_and\_level** – This 8-bit field shall identify the profile and level of the ISO/IEC 14496-2 video stream. This field shall be coded with the same value as the profile\_and\_level\_indication field in the Visual Object Sequence Header in the associated ISO/IEC 14496-2 stream.

### 2.6.38 MPEG-4 audio descriptor

For individual ISO/IEC 14496-3 streams directly carried in PES packets, as defined in 2.11.2, the MPEG-4 audio descriptor (see Table 2-73) provides basic information for identifying the coding parameters of such audio elementary streams. The MPEG-4 audio descriptor does not apply to ISO/IEC 14496-3 streams encapsulated in SL-packets and in M4Mux packets, as defined in 2.11.3.

**Table 2-73 – MPEG-4 audio descriptor**

Syntax	No. of bits	Mnemonic
MPEG-4_audio_descriptor () {		
<b>descriptor_tag</b>	<b>8</b>	<b>uimsbf</b>
<b>descriptor_length</b>	<b>8</b>	<b>uimsbf</b>
<b>MPEG-4_audio_profile_and_level</b>	<b>8</b>	<b>uimsbf</b>
}		

### 2.6.39 Semantic definition of fields in MPEG-4 audio descriptor

**MPEG-4\_audio\_profile\_and\_level** – This 8-bit field identifies the profile and level of the ISO/IEC 14496-3 audio stream corresponding to Table 2-74. If encoded with the value 0x0F, then it is signalled that no profile and level is defined for the associated MPEG-4 audio stream. The encoded value 0xFF indicates that the audio profile and level is not specified by the MPEG-4\_audio\_profile\_and\_level field; in that case, in addition to the MPEG-4 audio descriptor, an MPEG-4 audio extension descriptor shall be associated with the same MPEG-4 audio stream. In all other cases, next to an MPEG-4 audio descriptor, also an MPEG-4 audio extension descriptor may be associated with the same MPEG-4 audio stream.

**Table 2-74 – MPEG-4\_audio\_profile\_and\_level assignment values**

Value	Description
0x00 .. 0x0E	Reserved
0x0F	No audio profile and level defined for the associated MPEG-4 audio stream
0x10	Main profile, level 1
0x11	Main profile, level 2
0x12	Main profile, level 3
0x13	Main profile, level 4
0x14 .. 0x17	Reserved
0x18	Scalable Profile, level 1
0x19	Scalable Profile, level 2
0x1A	Scalable Profile, level 3

Table 2-74 – MPEG-4\_audio\_profile\_and\_level assignment values

Value	Description
0x1B 0x1C .. 0x1F	Scalable Profile, level 4 Reserved
0x20 0x21 0x22 .. 0x27 0x28 0x29 0x2A 0x2B .. 0x2F	Speech profile, level 1 Speech profile, level 2 Reserved Synthesis profile, level 1 Synthesis profile, level 2 Synthesis profile, level 3 Reserved
0x30 0x31 0x32 0x33 0x34 0x35 0x36 0x37 0x38 0x39 0x3A 0x3B 0x3C 0x3D 0x3E 0x3F	High quality audio profile, level 1 High quality audio profile, level 2 High quality audio profile, level 3 High quality audio profile, level 4 High quality audio profile, level 5 High quality audio profile, level 6 High quality audio profile, level 7 High quality audio profile, level 8 Low delay audio profile, level 1 Low delay audio profile, level 2 Low delay audio profile, level 3 Low delay audio profile, level 4 Low delay audio profile, level 5 Low delay audio profile, level 6 Low delay audio profile, level 7 Low delay audio profile, level 8
0x40 0x41 0x42 0x43 0x44 .. 0x47 0x48 0x49 0x4A 0x4B 0x4C 0x4D 0x4E .. 0x4F	Natural audio profile, level 1 Natural audio profile, level 2 Natural audio profile, level 3 Natural audio profile, level 4 Reserved Mobile audio internetworking profile, level 1 Mobile audio internetworking profile, level 2 Mobile audio internetworking profile, level 3 Mobile audio internetworking profile, level 4 Mobile audio internetworking profile, level 5 Mobile audio internetworking profile, level 6 Reserved
0x50 0x51 0x52 0x53 0x54 0x55 0x56 .. 0x57 0x58 0x59 0x5A 0x5B 0x5C 0x5D	AAC profile, level 1 AAC profile, level 2 AAC profile, level 4 AAC profile, level 5 AAC profile, level 6 AAC profile, level 7 Reserved High efficiency AAC profile, level 2 High efficiency AAC profile, level 3 High efficiency AAC profile, level 4 High efficiency AAC profile, level 5 High efficiency AAC profile, level 6 High efficiency AAC profile, level 7

Table 2-74 – MPEG-4\_audio\_profile\_and\_level assignment values

Value	Description
0x5E .. 0x5F	Reserved
0x60	High efficiency AAC v2 profile, level 2
0x61	High efficiency AAC v2 profile, level 3
0x62	High efficiency AAC v2 profile, level 4
0x63	High efficiency AAC v2 profile, level 5
0x64	High efficiency AAC v2 profile, level 6
0x65	High efficiency AAC v2 profile, level 7
0x66 .. 0x67	Reserved
0x68	Extended HE AAC Profile, level 1
0x69	Extended HE AAC Profile, level 2
0x6A	Extended HE AAC Profile, level 3
0x6B	Extended HE AAC Profile, level 4
0x6C	Extended HE AAC Profile, level 6
0x6D	Extended HE AAC Profile, level 7
0x6E .. 0x6F	Reserved
0x70	Baseline USAC Profile, level 1
0x71	Baseline USAC Profile, level 2
0x72	Baseline USAC Profile, level 3
0x73	Baseline USAC Profile, level 4
0x74 .. 0x7F	Reserved
0x80	Low Delay AAC Profile, level 1
0x81 .. 0x87	Reserved
0x88	Low Delay AAC v2 Profile, level 1
0x89	Low Delay AAC v2 Profile, level 2
0x8A	Low Delay AAC v2 Profile, level 3
0x8B	Low Delay AAC v2 Profile, level 4
0x8C .. 0x8F	Reserved
0x90	High Definition AAC Profile, level 1
0x91 .. 0x97	Reserved
0x98	ALS Simple Profile, level 1
0x99 .. 0xFE	Reserved
0xFF	Audio profile and level not specified by the MPEG-4_audio_profile_and_level field in this descriptor

#### 2.6.40 IOD descriptor

The IOD descriptor (see Table 2-75) encapsulates the InitialObjectDescriptor structure. An initial object descriptor allows access to a set of ISO/IEC 14496 streams by identifying the ES\_ID values of the ISO/IEC 14496-1 scene description and object descriptor streams. Both the scene description stream and the object descriptor stream contain further information about the ISO/IEC 14496 streams that are part of the scene. See Annex R for a description of the content access procedure. The InitialObjectDescriptor is specified in 7.2.6.4 of ISO/IEC 14496-1.

Within a transport stream, the IOD descriptor shall be conveyed in the descriptor loop immediately following the program\_info\_length field in the Program Map Table. If a program stream map is present in a program stream, the IOD descriptor shall be conveyed in the descriptor loop immediately following the program\_stream\_info\_length field in the program stream map. More than one IOD descriptor may be associated with a program.

NOTE – This Specification does not specify how the IOD\_label may be used by higher level service information to uniquely select one of the ISO/IEC 14496 presentations identified by multiple IOD descriptors.

Table 2-75 – IOD descriptor

Syntax	No. of bits	Mnemonic
IOD_descriptor () {		
<b>descriptor_tag</b>	<b>8</b>	<b>uimsbf</b>
<b>descriptor_length</b>	<b>8</b>	<b>uimsbf</b>
<b>Scope_of_IOD_label</b>	<b>8</b>	<b>uimsbf</b>
<b>IOD_label</b>	<b>8</b>	<b>uimsbf</b>
InitialObjectDescriptor ()		
}		

#### 2.6.41 Semantic definition of fields in IOD descriptor

**Scope\_of\_IOD\_label** – This 8-bit field specifies the scope of the IOD\_label field. A value of 0x10 indicates that the IOD\_label is unique within the program stream or within the specific program in a transport stream in which the IOD descriptor is carried. A value of 0x11 indicates that the IOD\_label is unique within the transport stream in which the IOD descriptor is carried. All other values of the Scope\_of\_IOD\_label field are reserved.

**IOD\_label** – This 8-bit field specifies the label of the IOD descriptor.

**InitialObjectDescriptor ()** – This structure is defined in 7.2.6.4 of ISO/IEC 14496-1.

#### 2.6.42 SL descriptor

The SL descriptor (see Table 2-76) shall be used when a single ISO/IEC 14496-1 SL-packetized stream is encapsulated in PES packets. The SL descriptor associates the ES\_ID of this SL-packetized stream to an elementary\_PID in case of a transport stream or to an elementary\_stream\_id in case of a program stream. Within a transport stream, the SL descriptor shall be conveyed for the corresponding elementary stream in the descriptor loop immediately following the ES\_info\_length field in the Program Map Table. If a program stream map is present in a program stream, the SL descriptor shall be conveyed in the descriptor loop immediately following the elementary\_stream\_info\_length field within the Program Stream Map.

NOTE – SL packetized streams may be used in a program stream. However, only one stream\_id exists for ISO/IEC 14496-1 SL-packetized streams. In order to associate multiple such streams within a program stream to an ISO/IEC 14496-1 scene, M4Mux has to be used and signalled appropriately by an FMC descriptor. This limitation does not exist in a transport stream where the SL descriptor provides unambiguous mapping between an ISO/IEC 14496-1 ES\_ID value and a Rec. ITU-T H.222.0 | ISO/IEC 13818-1 elementary\_PID value.

Table 2-76 – SL descriptor

Syntax	No. of bits	Mnemonic
SL_descriptor () {		
<b>descriptor_tag</b>	<b>8</b>	<b>uimsbf</b>
<b>descriptor_length</b>	<b>8</b>	<b>uimsbf</b>
<b>ES_ID</b>	<b>16</b>	<b>uimsbf</b>
}		

#### 2.6.43 Semantic definition of fields in SL descriptor

**ES\_ID** – This 16-bit field shall specify the identifier of an ISO/IEC 14496-1 SL-packetized stream.

#### 2.6.44 FMC descriptor

The FMC descriptor (see Table 2-77) indicates that the ISO/IEC 14496-1 M4Mux tool has been used to multiplex ISO/IEC 14496-1 SL-packetized streams into a M4Mux stream before encapsulation in PES packets or ISO/IEC14496\_sections. The FMC descriptor associates M4Mux channels to the ES\_ID values of the SL-packetized streams in the M4Mux stream.

An FMC descriptor is required for each program element referenced by an elementary\_PID value in a transport stream and for each elementary\_stream\_id in a program stream that conveys a M4Mux stream. Within a transport stream, the FMC descriptor shall be conveyed for the corresponding elementary stream in the descriptor loop immediately following the ES\_info\_length field in the Program Map Table. If a Program Stream Map is present in a program stream, the FMC descriptor shall be conveyed in the descriptor loop immediately following the elementary\_stream\_info\_length field in the program stream Map.

For each SL\_packetized stream in a M4Mux stream, the M4Mux channel shall be identified by a single entry in the FMC descriptor.

**Table 2-77 – FMC descriptor**

Syntax	No. of bits	Mnemonic
FMC_descriptor () {		
<b>descriptor_tag</b>	<b>8</b>	<b>uimsbf</b>
<b>descriptor_length</b>	<b>8</b>	<b>uimsbf</b>
for (i = 0; i < descriptor_length; i += 3) {		
<b>ES_ID</b>	<b>16</b>	<b>uimsbf</b>
<b>M4MuxChannel</b>	<b>8</b>	<b>uimsbf</b>
}		
}		

#### 2.6.45 Semantic definition of fields in FMC descriptor

**ES\_ID** – This 16-bit field specifies the identifier of an ISO/IEC 14496-1 SL-packetized stream.

**M4MuxChannel** – This 8-bit field specifies the number of the M4Mux channel used for this SL-packetized stream.

#### 2.6.46 External\_ES\_ID descriptor

The External\_ES\_ID descriptor (see Table 2-78) assigns an ES\_ID, as defined in ISO/IEC 14496-1, to a program element to which no ES\_ID value has been assigned by other means. This ES\_ID allows reference to a non-ISO/IEC 14496 component in the scene description or, for example, to associate a non-ISO/IEC 14496 component with an IPMP stream.

Within a transport stream, the assignment of an ES\_ID shall be made by conveying an External\_ES\_ID descriptor for the corresponding elementary stream in the descriptor loop immediately following the ES\_info\_length field in the Program Map Table. If a program stream map is present in a program stream, the External\_ES\_ID descriptor shall be conveyed in the descriptor loop immediately following the elementary\_stream\_info\_length field in the Program Stream Map.

**Table 2-78 – External\_ES\_ID descriptor**

Syntax	No. of bits	Mnemonic
External_ES_ID_descriptor () {		
<b>descriptor_tag</b>	<b>8</b>	<b>uimsbf</b>
<b>descriptor_length</b>	<b>8</b>	<b>uimsbf</b>
<b>External_ES_ID</b>	<b>16</b>	<b>uimsbf</b>
}		

#### 2.6.47 Semantic definition of fields in External\_ES\_ID descriptor

**External\_ES\_ID** – This 16-bit field assigns an ES\_ID identifier, as defined in ISO/IEC 14496-1, to a component of a program.

#### 2.6.48 Muxcode descriptor

The Muxcode descriptor (see Table 2-79) conveys MuxCodeTableEntry structures as defined in 7.4.2.5 of ISO/IEC 14496-1. MuxCodeTableEntries configure the MuxCode mode of M4Mux.

One or more Muxcode descriptors may be associated with each elementary\_PID or elementary\_stream\_id, respectively, conveying an ISO/IEC 14496-1 M4Mux stream that utilizes the MuxCode mode. Within a transport stream, the Muxcode descriptor shall be conveyed for the corresponding elementary stream in the descriptor loop immediately following the ES\_info\_length field in the Program Map Table. If a Program Stream Map is present in a program stream, the Muxcode descriptor shall be conveyed in the descriptor loop immediately following the elementary\_stream\_info\_length field in the Program Stream Map.

MuxCodeTableEntries may be updated with new versions. In case of such updates, the version\_number of each Program Map Table or the program\_stream\_map\_version of each Program Stream Map, respectively, carrying the MuxCode descriptor in their descriptor loop shall be incremented by 1 modulo 32.

**Table 2-79 – Muxcode descriptor**

Syntax	No. of bits	Mnemonic
Muxcode_descriptor () { <b>descriptor_tag</b> <b>descriptor_length</b> for (i = 0; i < N; i++) { MuxCodeTableEntry () } }	8 8	<b>uimsbf</b> <b>uimsbf</b>

**2.6.49 Semantic definition of fields in Muxcode descriptor**

**MuxCodeTableEntry ()** – This structure is defined in 7.4.2.5 of ISO/IEC 14496-1.

**2.6.50 M4MuxBufferSize descriptor**

The M4MuxBufferSize descriptor (see Table 2-80) conveys the size of the M4Mux buffer (FB) for each SL packetized stream multiplexed in a M4Mux stream.

One M4MuxBufferSize descriptor shall be associated with each elementary\_PID or elementary\_stream\_id, respectively, conveying an ISO/IEC 14496-1 M4Mux stream. Within a transport stream, the M4MuxBufferSize descriptor shall be conveyed for the corresponding elementary stream in the descriptor loop immediately following the ES\_info\_length field in the Program Map Table. If a Program Stream Map is present in a program stream, the M4MuxBufferSize descriptor shall be conveyed in the descriptor loop immediately following the elementary\_stream\_info\_length field within the Program Stream Map.

**Table 2-80 – M4MuxBufferSize descriptor**

Syntax	No. of bits	Mnemonic
M4MuxBufferSize_descriptor () { <b>descriptor_tag</b> <b>descriptor_length</b> <b>DefaultM4MuxBufferDescriptor()</b> for (i=0; i<descriptor_length; i += 4) { <b>M4MuxBufferDescriptor()</b> } }	8 8	<b>uimsbf</b> <b>uimsbf</b>

**2.6.51 Semantic definition of fields in M4MuxBufferSize descriptor**

**DefaultM4MuxBufferDescriptor()** – This descriptor specifies the default M4Mux buffer size for this M4Mux stream. It is defined in 7.4.2.8 of ISO/IEC 14496-1:2010.

**M4MuxBufferDescriptor()** – This descriptor specifies the M4Mux buffer size for one SL-packetized stream carried within the M4Mux stream. It is defined in 7.4.2.7 of ISO/IEC 14496-1:2010.

**2.6.52 MultiplexBuffer descriptor**

The MultiplexBuffer descriptor (see Table 2-81) conveys the size of the multiplex buffer MB<sub>n</sub>, as well as the leak rate R<sub>X<sub>n</sub></sub> at which data is transferred from transport buffer TB<sub>n</sub> into buffer MB<sub>n</sub> for a specific Rec. ITU-T H.222.0 | ISO/IEC 13818-1 program element referenced by an elementary\_PID value in the Program Map Table.

One MultiplexBuffer descriptor shall be associated with each elementary\_PID that contains an ISO/IEC 14496 M4Mux stream or SL-packetized stream, including those containing ISO\_IEC\_14496\_sections. See 2.11.3.9 for the definition of buffers and rates in the T-STD model for decoding of ISO/IEC 14496 content.

The MultiplexBuffer descriptor shall be conveyed in the descriptor loop immediately following the ES\_info\_length field in the Program Map Table.

Table 2-81 – MultiplexBuffer descriptor

Syntax	No. of bits	Mnemonic
MultiplexBuffer_descriptor () {		
<b>descriptor_tag</b>	8	<b>uimsbf</b>
<b>descriptor_length</b>	8	<b>uimsbf</b>
<b>MB_buffer_size</b>	24	<b>uimsbf</b>
<b>TB_leak_rate</b>	24	<b>uimsbf</b>
}		

### 2.6.53 Semantic definition of fields in MultiplexBuffer descriptor

**MB\_buffer\_size** – This 24-bit field shall specify the size in byte of buffer MB<sub>n</sub> of the elementary stream n that is associated with this descriptor.

**TB\_leak\_rate** – This 24-bit field shall specify in units of 400 bits per second the rate at which data is transferred from transport buffer TB<sub>n</sub> to multiplex buffer MB<sub>n</sub> for the elementary stream n that is associated with this descriptor.

### 2.6.54 M4MuxTiming descriptor

See Table 2-82.

Table 2-82 – M4MuxTiming descriptor

Syntax	No. of bits	Mnemonic
M4MuxTiming_descriptor () {		
<b>descriptor_tag</b>	8	<b>uimsbf</b>
<b>descriptor_length</b>	8	<b>uimsbf</b>
<b>FCR_ES_ID</b>	16	<b>uimsbf</b>
<b>FCRResolution</b>	32	<b>uimsbf</b>
<b>FCRLength</b>	8	<b>uimsbf</b>
<b>FmxRateLength</b>	8	<b>uimsbf</b>
}		

### 2.6.55 Semantic definition of fields in M4MuxTiming descriptor

**FCR\_ES\_ID** – is the ES\_ID associated with this clock reference stream

**FCRResolution** – is the resolution of the object time base in cycles per second

**FCRLength** – is the length of the fmxClockReference field in M4Mux packets with index = 238. A length of zero shall indicate that no M4Mux packets with index = 238 are present in this M4Mux stream. FCRLength shall take values between zero and 64.

**FmxRateLength** – Is the length of the fmxRate field in M4Mux packets with index = 238? FmxRateLength shall take values between 1 and 32.

### 2.6.56 Content labelling descriptor

The content labelling descriptor assigns a label to content; the label can be used by metadata to reference the associated content. This label, the content\_reference\_id\_record, is metadata application format specific. The content labelling descriptor is associated with a content segment. For the purpose of this clause, a content segment is defined as a portion in time of a program, an elementary stream (such as audio or video) or any combination of programs or elementary streams. The descriptor may be included in the PMT in the descriptor loop for either the program or an elementary stream, but may also be contained in tables not defined in this Specification, for example tables to describe segments of programs or elementary streams. The content labelling descriptor also provides information on which content time base is used and on the offset between the content time base and the metadata time base. When the Normal Play Time (NPT) concept of DSM-CC, as specified in ISO/IEC 13818-6, is used as the content time base, the ID of the NPT time base is provided. The descriptor allows for carriage of private data. See Table 2-83.

Table 2-83 – Content labelling descriptor

Syntax	No. of bits	Mnemonic
Content_labelling_descriptor () {		
<b>descriptor_tag</b>	8	uimsbf
<b>descriptor_length</b>	8	uimsbf
<b>metadata_application_format</b>	16	uimsbf
if (metadata_application_format== 0xFFFF){		
<b>metadata_application_format_identifier</b>	32	uimsbf
}		
<b>content_reference_id_record_flag</b>	1	bslbf
<b>content_time_base_indicator</b>	4	uimsbf
<b>reserved</b>	3	bslbf
if (content_reference_id_record_flag == '1'){		
<b>content_reference_id_record_length</b>	8	uimsbf
for (i=0; i<content_reference_id_record_length;i++){		
<b>content_reference_id_byte</b>	8	bslbf
}		
}		
if (content_time_base_indicator == 1    content_time_base_indicator == 2){		
<b>reserved</b>	7	bslbf
<b>content_time_base_value</b>	33	uimsbf
<b>reserved</b>	7	bslbf
<b>metadata_time_base_value</b>	33	uimsbf
}		
if (content_time_base_indicator==2){		
<b>reserved</b>	1	bslbf
<b>contentId</b>	7	uimsbf
}		
if (content_time_base_indicator ≥ 3 && content_time_base_indicator ≤ 7){		
<b>time_base_association_data_length</b>	8	uimsbf
for (i=0; i<time_base_association_data_length;i++){		
<b>reserved</b>	8	bslbf
}		
}		
for (i=0; i<N;i++){		
<b>private_data_byte</b>	8	bslbf
}		
}		

2.6.57 Semantic definition of fields in content labelling descriptor

**metadata\_application\_format:** The metadata\_application\_format is a 16-bit field, coded as defined in Table 2-84, that specifies the application responsible for defining usage, syntax and semantics of the content\_reference\_id record and of any other privately defined fields in this descriptor. See also 2.12.1. The value 0xFFFF indicates that the format is signalled by the value carried in the metadata\_application\_format\_identifier field.

Table 2-84 – Metadata\_application\_format

Value	Description
0x0000 .. 0x000F	Reserved
0x0010	ISO 15706-1 (ISAN) encoded in its binary form (see Notes 1 and 3)
0x0011	ISO 15706-2 (V-ISAN) encoded in its binary form (see Notes 2 and 3)
0x0012 .. 0x00FF	Reserved
0x0100 .. 0xFFFE	User defined
0xFFFF	Defined by the metadata_application_format_identifier field

NOTE 1 – For ISAN, the content\_reference\_id\_byte is set to binary encoding and the content\_reference\_id\_record\_length is set to 0x08.

NOTE 2 – For V-ISAN, the content\_reference\_id\_byte is set to binary encoding and the content\_reference\_id\_record\_length is set to 0x0C.

NOTE 3 – For interoperability amongst metadata applications that use the metadata\_application\_format values of 0x0010 and 0x0011, it is recommended that the content\_reference\_id\_flag be set to '1' and the content\_time\_base\_indicator be set to '00'.

**metadata\_application\_format\_identifier:** The coding of this 32-bit field is fully equivalent to the coding of the format\_identifier field in the registration\_descriptor, as defined in 2.6.8.

NOTE – The assigned Registration Authority for the format\_identifier field is SMPTE.

**content\_reference\_id\_record\_flag:** The `content_reference_id_record_flag` is a 1-bit flag that signals the presence of a `content_reference_id_record` in this descriptor.

**content\_time\_base\_indicator:** The `content_time_base_indicator` (see Table 2-85) is a 4-bit field which specifies the used content time base. If the descriptor is associated with a program, then the content time base applies to all streams that are part of that program. A value of 1 indicates usage of the STC, while a value of 2 indicates usage of NPT, the Normal Play Time as defined in ISO/IEC 13818-6. The values between 8 and 15 indicate usage of a privately defined content time base. If coded with a value of 0, no content time base is defined in this descriptor. If no content time base is specified for a program or stream, then the mapping of time references in the metadata to the content is not defined in this Specification.

**Table 2-85 – Content\_time\_base\_indicator values**

Value	Description
0	No content time base defined in this descriptor
1	Use of STC
2	Use of NPT
3 .. 7	Reserved
8 .. 15	Use of privately defined content time base

**content\_reference\_id\_record\_length:** The `content_reference_id_record_length` is an 8-bit field that specifies the number of `content_reference_id_bytes` immediately following this field. This field shall not be coded with the value '0'.

**content\_reference\_id\_byte:** The `content_reference_id_byte` is part of a string of one or more contiguous bytes that assigns one or more reference identifications (labels) to the content to which this descriptor is associated. The format of this byte string is defined by the body indicated by the coded value in the `metadata_application_format` field.

**content\_time\_base\_value:** The `content_time_base_value` is a 33-bit field that specifies a value in units of 90 kHz of the content time base indicated by the `content_time_base_indicator` field.

**metadata\_time\_base\_value:** The `metadata_time_base_value` is a 33-bit field that is coded in units of 90 kHz. The field is coded with the value of the metadata time base at the instant in time in which the time base indicated by `content_time_base_indicator` reaches the value encoded in the `content_time_base_value` field. Note that the metadata time base may use any time-scale, but that its value is to be coded in units of 90 kHz. For example, if a SMPTE type of time code is used, then the number of hours, minutes, seconds and frames is expressed in the corresponding number of 90-kHz units.

**contentId:** The `contentId` is a 7-bit field that specifies the value of the `content_Id` field in the NPT Reference Descriptor for the applied NPT time base.

**time\_base\_association\_data\_length:** The `time_base_association_data_length` is an 8-bit field that specifies the number of reserved bytes immediately following this field. The reserved bytes can be used to carry time base association data for time bases defined in future.

**private\_data\_byte:** The `private_data_byte` is an 8-bit field. The `private_data_bytes` represent data, the format of which is defined privately. These bytes can be used to provide additional information as deemed appropriate. The use of these bytes is defined by the metadata application format.

## 2.6.58 Metadata pointer descriptor

The metadata pointer descriptor (see Table 2-86) points to a single metadata service and associates this metadata service with audiovisual content in a Rec. ITU-T H.222.0 | ISO/IEC 13818-1 stream. The metadata is associated with the content within the context of the descriptor. The context is defined by the location of the descriptor. In a transport stream, the descriptor may be located in the PMT in the descriptor loop for either the program or an elementary stream, but may also be located in tables not defined in this Specification, such as tables describing bouquets of broadcast services. The metadata may be located in a Rec. ITU-T H.222.0 | ISO/IEC 13818-1 stream, but the same metadata may also be provided on alternative locations, such as the Internet.

The descriptor may contain location information of metadata that is not carried in a Rec. ITU-T H.222.0 | ISO/IEC 13818-1 stream; the coding of the location information is metadata application format specific. The descriptor allows for carriage of private data.

For metadata carried in a Rec. ITU-T H.222.0 | ISO/IEC 13818-1 stream, the descriptor specifies the tools used for such carriage. If the metadata is carried in PES packets, metadata sections, or ISO/IEC 13818-6 synchronized download sections, the `metadata_service_id` field identifies the metadata service in the referenced metadata stream. If an ISO/IEC 13818-6 carousel is used to carry the metadata, then the private data may provide information to signal the

metadata service, such as the applied value of the module\_id for carriage of the metadata in a data carousel, and the file name of the metadata when the object carousel is used.

Receivers should be aware that multiple metadata services may be pointed to from the same program or audiovisual stream (as defined by the context of the descriptor). A unique metadata pointer descriptor shall be used to point to each metadata service used by the program or audiovisual stream. Similarly, the same metadata service can be pointed to from several programs or audiovisual streams by using a separate metadata pointer descriptors for each association.

**Table 2-86 – Metadata pointer descriptor**

Syntax	No. of bits	Mnemonic
Metadata_pointer_descriptor () {		
descriptor_tag	8	uimsbf
descriptor_length	8	uimsbf
metadata_application_format	16	uimsbf
if (metadata_application_format == 0xFFFF){		
metadata_application_format_identifier	32	uimsbf
}		
metadata_format	8	uimsbf
if (metadata_format == 0xFF){		
metadata_format_identifier	32	uimsbf
}		
metadata_service_id	8	uimsbf
metadata_locator_record_flag	1	bslbf
MPEG_carriage_flags	2	uimsbf
reserved	5	bslbf
if (metadata_locator_record_flag == '1'){		
metadata_locator_record_length	8	uimsbf
for ( i = 0; i < metadata_locator_record_length; i++){		
metadata_locator_record_byte	8	bslbf
}		
}		
if (MPEG_carriage_flags ≤ 2){		
program_number	16	uimsbf
}		
if (MPEG_carriage_flags == 1){		
transport_stream_location	16	uimsbf
transport_stream_id	16	uimsbf
}		
for (i=0; i<N;i++){		
private_data_byte	8	bslbf
}		
}		

**2.6.59 Semantic definition of fields in metadata pointer descriptor**

**metadata\_application\_format:** The metadata\_application\_format is a 16-bit field that specifies the application responsible for defining usage, syntax and semantics of the metadata\_locator\_record record and any other privately defined fields in this descriptor. The coding of this field is defined in Table 2-84 in 2.6.57.

**metadata\_application\_format\_identifier:** The coding of this field is defined in 2.6.57.

**metadata\_format:** The metadata\_format is an 8-bit field that indicates the format and coding of the metadata. The coding of this field is specified in Table 2-87.

**Table 2-87 – Metadata format values**

Value	Description
0x00 .. 0x0F	Reserved
0x10	ISO/IEC 15938-1 TeM
0x11	ISO/IEC 15938-1 BiM
0x12 .. 0x3E	Reserved
0x3F	Defined by metadata application format
0x40 .. 0xFE	Private use
0xFF	Defined by metadata_format_identifier field

The values 0x10 and 0x11 identify ISO/IEC 15938-1 defined data. The value 0x3F indicates that the format is defined by the body indicated by the `metadata_application_format` field. The values in the inclusive range of 0x40 up to 0xFE are available to signal use of private formats. The value 0xFF indicates that the format is signalled by the `metadata_format_identifier` field.

**metadata\_format\_identifier:** The coding of this 32-bit field is fully equivalent to the coding of the `format_identifier` field in the `registration_descriptor`, as defined in 2.6.8.

NOTE – SMPTE is assigned as Registration Authority for the `format_identifier` field.

**metadata\_service\_id:** This 8-bit field references the metadata service. It is used for retrieving a metadata service from within a metadata stream.

**metadata\_locator\_record\_flag:** The `metadata_locator_record_flag` is a 1-bit field which, when set to '1' indicates that associated metadata is available on a location outside of a Rec. ITU-T H.222.0 | ISO/IEC 13818-1 stream, specified in a `metadata_locator_record`.

**MPEG\_carriage\_flags:** The `MPEG_carriage_flags` is a 2-bit field which specifies if the metadata stream containing the associated metadata service is carried in a Rec. ITU-T H.222.0 | ISO/IEC 13818-1 stream, and if so, whether the associated metadata is carried in a transport stream or program stream. The coding of this field is defined in Table 2-88.

Table 2-88 – MPEG\_carriage\_flags

Value	Description
0	Carriage in the same transport stream where this metadata pointer descriptor is carried.
1	Carriage in a different transport stream from where this metadata pointer descriptor is carried.
2	Carriage in a program stream. This may or may not be the same program stream in which this metadata pointer descriptor is carried.
3	None of the above.

**metadata\_locator\_record\_length:** The `metadata_locator_record_length` is an 8-bit field that specifies the number of `metadata_locator_record_bytes` immediately following. This field shall not be coded with the value 0.

**metadata\_locator\_record\_byte:** The `metadata_locator_record_byte` is part of a string of one or more contiguous bytes that form the metadata locator record. This record specifies one or more locations outside of a Rec. ITU-T H.222.0 | ISO/IEC 13818-1 stream. The format of the metadata locator record is defined by the metadata application signalled by the `metadata_application_format` field. The record may for example contain Internet URLs that specify where the metadata can be found, possibly in addition to their location(s) in the transport stream. If the `MPEG_carriage_flags` is coded with the value 0, 1 or 2 and the metadata locator record is present, then this signals alternative locations for the same metadata.

**program\_number:** The `program_number` is a 16-bit field that identifies the `program_number` of the MPEG-2 program in the Rec. ITU-T H.222.0 | ISO/IEC 13818-1 stream in which associated metadata is carried. If the `MPEG_carriage_flags` have the value 0, then the transport stream is the current one, and if the `MPEG_carriage_flags` have the value 1, it is the transport stream signalled by the field's `transport_stream_location` and `transport_stream_id`.

**transport\_stream\_location:** The `transport_stream_location` is a 16-bit field that is defined privately. For example, this field may be used by applications to signal the `original_network_id` defined by ETSI.

**transport\_stream\_id:** The `transport_stream_id` is a 16-bit field that identifies the transport stream in which associated metadata is carried.

**private\_data\_byte:** The `private_data_byte` is an 8-bit field. The `private_data_bytes` represent data, the format of which is defined privately. These bytes can be used to provide additional information as deemed appropriate.

## 2.6.60 Metadata descriptor

The metadata descriptor (see Table 2-89) specifies parameters of a metadata service carried in an MPEG-2 TS or PS. In an MPEG-2 TS, the descriptor is included in the PMT in the descriptor loop for the elementary stream that carries the metadata service. The descriptor specifies the format of the associated metadata, and contains the value of the `metadata_service_id` to identify the metadata service to which the metadata descriptor applies. As needed, the descriptor can convey information to identify the metadata service from a collection of metadata transmitted in a DSM-CC carousel. Optionally metadata application format specific private data can be carried.

The metadata descriptor also signals whether decoder configuration is required and is able to carry the decoder configuration bytes, but this is only practical if the number of these bytes is small. If the decoder configuration information is too large to be carried by the descriptor, it shall be contained in a metadata service. This may be within the metadata service itself, or in another metadata service within the same program. Identification of the metadata service that contains the decoder configuration is provided by the metadata descriptor. If a DSM-CC carousel is used to carry the decoder configuration, then information can be provided how to retrieve the decoder configuration from the carousel.

**Table 2-89 – Metadata descriptor**

Syntax	No. of bits	Mnemonic
Metadata_descriptor () {		
<b>descriptor_tag</b>	8	uimsbf
<b>descriptor_length</b>	8	uimsbf
<b>metadata_application_format</b>	16	uimsbf
if (metadata_application_format == 0xFFFF) {		
<b>metadata_application_format_identifier</b>	32	uimsbf
}		
<b>metadata_format</b>	8	uimsbf
if (metadata_format == 0xFF) {		
<b>metadata_format_identifier</b>	32	uimsbf
}		
<b>metadata_service_id</b>	8	uimsbf
<b>decoder_config_flags</b>	3	bslbf
<b>DSM-CC_flag</b>	1	bslbf
<b>reserved</b>	4	bslbf
if (DSM-CC_flag == '1') {		
<b>service_identification_length</b>	8	uimsbf
for(i=0; i<service_identification_length; i++) {		
<b>service_identification_record_byte</b>	8	bslbf
}		
}		
if (decoder_config_flags == '001') {		
<b>decoder_config_length</b>	8	uimsbf
for(i=0; i<decoder_config_length; i++) {		
<b>decoder_config_byte</b>	8	bslbf
}		
}		
if (decoder_config_flags == '011') {		
<b>dec_config_identification_record_length</b>	8	uimsbf
for(i=0; i<dec_config_id_record_length; i++) {		
<b>dec_config_identification_record_byte</b>	8	bslbf
}		
}		
if (decoder_config_flags == '100') {		
<b>decoder_config_metadata_service_id</b>	8	uimsbf
}		
if (decoder_config_flags == '101'    decoder_config_flags == '110') {		
<b>reserved_data_length</b>	8	uimsbf
for(i=0; i<reserved_data_length; i++) {		
<b>reserved</b>	8	bslbf
}		
}		
for (i=0; i<N; i++) {		
<b>private_data_byte</b>	8	bslbf
}		
}		

**2.6.61 Semantic definition of fields in metadata descriptor**

**metadata\_application\_format:** The metadata\_application\_format is a 16-bit field that specifies the application responsible for defining usage, syntax and semantics of the service\_identification\_record and any privately defined bytes in this descriptor. The coding of this field is defined in Table 2-84.

**metadata\_application\_format\_identifier:** The coding of this field is defined in 2.6.57.

**metadata\_format:** The coding of this field is defined in 2.6.59.

**metadata\_format\_identifier:** The coding of this field is defined in 2.6.59.

**metadata\_service\_id.** This 8-bit field identifies the metadata service to which this metadata descriptor applies.

**decoder\_config\_flags:** The decoder\_config\_flags is a 3-bit field which indicates whether and how decoder configuration information is conveyed. See Table 2-90.

**Table 2-90 – decoder\_config\_flags**

Value	Description
'000'	No decoder configuration is needed.
'001'	The decoder configuration is carried in this descriptor in the decoder_config_byte field.
'010'	The decoder configuration is carried in the same metadata service as to which this metadata descriptor applies.
'011'	The decoder configuration is carried in a DSM-CC carousel. This value shall only be used if the metadata service to which this descriptor applies is using the same type of DSM-CC carousel.
'100'	The decoder configuration is carried in another metadata service within the same program, as identified by the decoder_config_metadata_service_id field in this metadata descriptor.
'101' .. '110'	Reserved.
'111'	Privately defined.

**DSM-CC\_flag:** This is a one-bit flag that is set to '1' if the stream with which this descriptor is associated is carried in an ISO/IEC 13818-6 data or object carousel.

NOTE 1 – The use of the object or data carousel is indicated by the applied stream-type value for this metadata stream.

**service\_identification\_length:** This field specifies the number of service\_identification\_record\_bytes immediately following.

**service\_identification\_record\_byte:** This byte is part of a string of one or more contiguous bytes that specify the service\_identification\_record. This record contains data on retrieval of the metadata service from a DSM-CC carousel. The format of the metadata locator record is defined by the application indicated by the metadata application format. When a DSM-CC object carousel is used, the record may for example comprise the unique object identifier (the IOP:IOR() from 11.3.1 and 5.7.2.3 of ISO/IEC 13818-6 DSM-CC) for the metadata service. Similarly, in case of a DSM-CC data carousel, the record can for example provide the transaction\_id and the module\_id of the metadata service.

**decoder\_config\_length:** This field specifies the number of decoder\_config\_bytes immediately following.

**decoder\_config\_byte:** These bytes comprise the decoder configuration information. This sequence of bytes comprises the configuration information needed by the receiver to decode this service. It is intended that carriage in the metadata descriptor is only used when the configuration information is very small.

**dec\_config\_identification\_record\_length:** This field specifies the immediately following number of dec\_config\_identification\_record\_bytes.

**dec\_config\_identification\_record\_byte:** This byte is part of a string of one or more contiguous bytes that specify the dec\_config\_identification\_record. This record specifies how to retrieve the required decoder configuration from a DSM-CC carousel. The format of the metadata locator record is defined by the metadata application format. When a DSM-CC object carousel is used, the record may for example comprise the unique object identifier (the IOP:IOR() from 11.3.1 and 5.7.2.3 of ISO/IEC 13818-6 DSM-CC) for the decoder configuration. Similarly, in case of a DSM-CC data carousel, the record may for example provide the transaction\_id and the module\_id of the decoder configuration.

**decoder\_config\_metadata\_service\_id:** This is the value of the metadata\_service\_id that is assigned to the metadata service that contains the decoder configuration. The metadata service indicated by the decoder\_config\_metadata\_service\_id and the metadata service that uses that decoder configuration shall be in the same program. Hence in a transport stream, the metadata descriptors for both these metadata services shall be in the same PMT. The metadata descriptor of the metadata service indicated by the decoder\_config\_metadata\_service\_id shall have a decoder\_config\_flag field with a value of either '001', '010' or '011'.

**reserved\_data\_length:** This field specifies the number of reserved bytes immediately following.

**private\_data\_byte:** The private\_data\_byte is an 8-bit field. The private\_data\_bytes represent data, the format of which is defined privately. These bytes can be used to provide additional information as deemed appropriate.

## 2.6.62 Metadata STD descriptor

This descriptor defines parameters of the STD model (defined in 2.12.10) for the processing of the metadata stream to which this descriptor is associated. See Table 2-91.

Table 2-91 – Metadata STD descriptor

Syntax	No. of bits	Mnemonic
Metadata_STD_descriptor () {		
<b>descriptor_tag</b>	8	<b>uimsbf</b>
<b>descriptor_length</b>	8	<b>uimsbf</b>
<b>reserved</b>	2	<b>bslbf</b>
<b>metadata_input_leak_rate</b>	22	<b>uimsbf</b>
<b>reserved</b>	2	<b>bslbf</b>
<b>metadata_buffer_size</b>	22	<b>uimsbf</b>
<b>reserved</b>	2	<b>bslbf</b>
<b>metadata_output_leak_rate</b>	22	<b>uimsbf</b>
}		

2.6.63 Semantic definition of fields in metadata STD descriptor

**metadata\_input\_leak\_rate:** The metadata\_input\_leak\_rate is a 22-bit field that specifies the leak rate for the associated metadata stream in the T-STD model out of the buffer TB<sub>n</sub> into buffer B<sub>n</sub>. The leak rate is specified in units of 400 bits/s. For metadata carried in a program stream, the coding of the metadata\_input\_leak\_rate field is not specified, as the rate into B<sub>n</sub> equals the rate of the program stream.

**metadata\_buffer\_size:** The metadata\_buffer\_size is a 22-bit field that specifies the size of buffer B<sub>n</sub> in the STD model for the associated metadata stream. The size of B<sub>n</sub> is specified in units of 1024 bytes.

**metadata\_output\_leak\_rate:** The metadata\_output\_leak\_rate is a 22-bit field that specifies for the associated metadata service the leak rate in the STD model out of buffer B<sub>n</sub> to the decoder. The leak rate is specified in units of 400 bits/s. For metadata streams transported synchronously (stream-type 0x15 or 0x19), the metadata access units are instantaneously removed from B<sub>n</sub> under the control of PTS timestamps and in that case the coding of the metadata\_output\_leak\_rate field is not specified.

2.6.64 AVC video descriptor

For AVC video streams, the AVC video descriptor provides basic information for identifying coding parameters of the associated AVC video stream, such as on profile and level parameters included in the SPS of an AVC video stream or in the subset SPS of an SVC video sub-bitstream.

For AVC video streams conforming to one or more profiles defined in Annex G, or Annex H or Annex I of Rec. ITU-T H.264 | ISO/IEC 14496 10, there may be one AVC video descriptor associated to each of the video sub-bitstreams, or MVC video subsets or MVCD video subsets identifying coding parameters of the associated re-assembled AVC video streams.

The AVC video descriptor also signals the presence of AVC still pictures, AVC 24-hour pictures as well as 3D rendering assistance SEIs such as frame packing arrangement SEI message or stereo video information SEI message in the AVC video stream. If this descriptor is not included in the PMT for an AVC video stream, a video sub-bitstream, or an MVC video sub-bitstream or an MVCD video sub-bitstream in a transport stream or in the PSM, if present, for an AVC video stream, a video sub bitstream or an MVC video sub-bitstream in a program stream, then such AVC video stream shall not contain AVC still pictures, shall not contain AVC 24-hour pictures and may or may not contain frame packing arrangement SEI message or stereo video information SEI message. (See Table 2-92.)

Table 2-92 – AVC video descriptor

Syntax	No. of bits	Mnemonic
AVC_video_descriptor() {		
<b>descriptor_tag</b>	8	<b>uimsbf</b>
<b>descriptor_length</b>	8	<b>uimsbf</b>
<b>profile_idc</b>	8	<b>uimsbf</b>
<b>constraint_set0_flag</b>	1	<b>bslbf</b>
<b>constraint_set1_flag</b>	1	<b>bslbf</b>
<b>constraint_set2_flag</b>	1	<b>bslbf</b>
<b>constraint_set3_flag</b>	1	<b>bslbf</b>
<b>constraint_set4_flag</b>	1	<b>bslbf</b>
<b>constraint_set5_flag</b>	1	<b>bslbf</b>
<b>AVC_compatible_flags</b>	2	<b>bslbf</b>
<b>level_idc</b>	8	<b>uimsbf</b>

Table 2-92 – AVC video descriptor

Syntax	No. of bits	Mnemonic
AVC_still_present	1	bslbf
AVC_24_hour_picture_flag	1	bslbf
Frame_Packing_SEI_not_present_flag	1	bslbf
reserved	5	bslbf
}		

### 2.6.65 Semantic definition of fields in AVC video descriptor

**profile\_idc, constraint\_set0\_flag, constraint\_set1\_flag, constraint\_set2\_flag, constraint\_set3\_flag, constraint\_set4\_flag, constraint\_set5\_flag and AVC\_compatible\_flags and level\_idc** – These fields, with the exception of AVC\_compatible\_flags, shall be coded according to the semantics for these fields defined in Rec. ITU-T H.264 | ISO/IEC 14496-10. The semantics of AVC\_compatible\_flags are exactly equal to the semantics of the field(s) defined for the 2 bits between the *constraint\_set5\_flag* and the *level\_idc* field in the sequence parameter set, as defined in Rec. ITU-T H.264 | ISO/IEC 14496-10. The entire AVC video stream to which the AVC descriptor is associated shall conform to the profile, level and constraints signalled by these fields.

NOTE – In one or more sequences in the AVC video stream the level may be lower than the level signalled in the AVC video descriptor, while also a profile may occur that is a subset of the profile signalled in the AVC video descriptor. However, in the entire AVC video stream, only tools shall be used that are included in the profile signalled in the AVC video descriptor, if present. For example, if the main profile is signalled, then the baseline profile may be used in some sequences, but only using those tools that are in the main profile. If the sequence parameter sets in an AVC video stream signal different profiles, and no additional constraints are signalled, then the stream may need examination to determine which profile, if any, the entire stream conforms to. If an AVC video descriptor is to be associated with an AVC video stream that does not conform to a single profile, then the AVC video stream must be partitioned into two or more sub-streams, so that AVC video descriptors can signal a single profile for each such sub-stream.

**AVC\_still\_present** – This 1-bit field when set to '1' indicates that the AVC video stream may include AVC still pictures. When set to '0', then the associated AVC video stream shall not contain AVC still pictures.

**AVC\_24\_hour\_picture\_flag** – This 1-bit flag when set to '1' indicates that the associated AVC video stream may contain AVC 24-hour pictures. For the definition of an AVC 24-hour picture, see 2.1.2. If this flag is set to '0', the associated AVC video stream shall not contain any AVC 24-hour picture.

**Frame\_Packing\_SEI\_not\_present\_flag** – If this flag is set to '0', then the AVC video stream shall contain either the frame packing arrangement SEI message or stereo video information SEI message. If the AVC video descriptor is present and this flag is set to '1', then the presence of either of these SEI messages is unspecified.

### 2.6.66 AVC timing and HRD descriptor

The AVC timing and HRD descriptor provides timing and HRD parameters of the associated AVC video stream. For each AVC video stream and for each video sub-bitstream or MVC video sub-bitstream or MVCD video sub-bitstream carried in a Rec. ITU-T H.222.0 | ISO/IEC 13818-1 stream, the AVC timing and HRD descriptor shall be included in the PMT or in the PSM, if PSM is present in the program stream, unless the AVC video stream, the video sub-bitstream or the MVC video sub-bitstream or MVCD video sub-bitstream carries VUI parameters with the *timing\_info\_present\_flag* set to '1':

- for each IDR picture or re-assembled IDR picture; and
- for each picture or re-assembled picture that is associated with a recovery point SEI message.

Absence of the AVC timing and HRD descriptor in the PMT for an AVC video stream or a re-assembled AVC video stream signals usage of the leak method in the T-STD for the transfer from  $MB_n$  to  $EB_n$  as defined:

- in 2.14.3.1 for an AVC video stream conforming to one or more profiles defined in Annex A of Rec. ITU-T H.264 | ISO/IEC 14496-10;
- in 2.14.3.5 for video sub-bitstreams of an AVC video stream conforming to one or more profiles defined in Annex G of Rec. ITU-T H.264 | ISO/IEC 14496-10;
- in 2.14.3.7 for MVC video sub-bitstreams or MVCD video sub-bitstreams of an AVC video stream conforming to one or more profiles defined in Annex H of Rec. ITU-T H.264 | ISO/IEC 14496-10.

But such usage can also be signalled by the *hrd\_management\_valid\_flag* set to '0' in the AVC timing and HRD descriptor. If the transfer rate into buffer  $EB_n$  can be determined from HRD parameters contained in an AVC video stream or an AVC video stream re-assembled from video sub-bitstreams or MVC video sub-bitstreams or MVCD video sub-bitstreams, and if this transfer rate is used in the T-STD for the transfer between  $MB_n$  to  $EB_n$ , then the AVC timing and

HRD descriptor with the `hrd_management_valid_flag` set to '1' shall be included in the PMT for that AVC video stream or for the re-assembled AVC video stream. (See Table 2-93.)

**Table 2-93 – AVC timing and HRD descriptor**

Syntax	No. of bits	Mnemonic
AVC_timing_and_HRD_descriptor () {		
<b>descriptor_tag</b>	8	<b>uimsbf</b>
<b>descriptor_length</b>	8	<b>uimsbf</b>
<b>hrd_management_valid_flag</b>	1	<b>bslbf</b>
<b>reserved</b>	6	<b>bslbf</b>
<b>picture_and_timing_info_present</b>	1	<b>bslbf</b>
if (picture_and_timing_info_present) {		
<b>90kHz_flag</b>	1	<b>bslbf</b>
<b>reserved</b>	7	<b>bslbf</b>
if (90kHz_flag == '0') {		
<b>N</b>	32	<b>uimsbf</b>
<b>K</b>	32	<b>uimsbf</b>
}		
<b>num_units_in_tick</b>	32	<b>uimsbf</b>
}		
<b>fixed_frame_rate_flag</b>	1	<b>bslbf</b>
<b>temporal_poc_flag</b>	1	<b>bslbf</b>
<b>picture_to_display_conversion_flag</b>	1	<b>bslbf</b>
<b>reserved</b>	5	<b>bslbf</b>
}		

**2.6.67 Semantic definition of fields in AVC timing and HRD descriptor**

**hrd\_management\_valid\_flag** – This 1-bit field is only defined for use in transport streams.

When the AVC timing and HRD descriptor is associated with an AVC video stream or a re-assembled AVC video stream carried in a transport stream, then the following applies. If the `hrd_management_valid_flag` is set to '1', then Buffering Period SEI and Picture Timing SEI messages, as defined in Annex C of Rec. ITU-T H.264 | ISO/IEC 14496-10, shall be present in the associated AVC video stream or re-assembled AVC video stream. These Buffering Period SEI messages shall carry coded initial\_cpb\_removal\_delay and initial\_cpb\_removal\_delay\_offset values for the NAL HRD. If the `hrd_management_valid_flag` is set to '1', then the transfer of each byte from MB<sub>n</sub> to EB<sub>n</sub> in the T-STD shall be according to the delivery schedule for that byte into the CPB in the NAL HRD, as determined from the coded initial\_cpb\_removal\_delay and initial\_cpb\_removal\_delay\_offset values for SchedSelIdx = cpb\_cnt\_minus1. When the `hrd_management_valid_flag` is set to '0', the leak method for the transfer from MB<sub>n</sub> to EB<sub>n</sub> in the T-STD shall be used:

- as defined in 2.14.3.1 for AVC video streams conforming to one or more profiles defined in Annex A of Rec. ITU-T H.264 | ISO/IEC 14496-10;
- as defined in 2.14.3.5 for video sub-bitstreams of AVC video streams conforming to one or more profiles defined in Annex G of Rec. ITU-T H.264 | ISO/IEC 14496-10.
- as defined in 2.14.3.7 for MVC video sub-bitstreams or MVCD video sub-bitstreams of AVC video streams conforming to one or more profiles defined in Annex H of Rec. ITU-T H.264 | ISO/IEC 14496-10.

When the AVC timing and HRD descriptor is associated with an AVC video stream or a re-assembled AVC video stream carried in a program stream, then the meaning of the `hrd_management_valid_flag` is not defined.

**picture\_and\_timing\_info\_present** – This 1-bit field when set to '1' indicates that the `90kHz_flag` and parameters for accurate mapping to 90-kHz system clock are included in this descriptor.

**90kHz\_flag, N, K** – The `90kHz_flag` when set to '1' indicates that the frequency of the AVC time base is 90 kHz. For an AVC video stream the frequency of the AVC time base is defined by the AVC parameter `time_scale` in VUI parameters, as defined in Annex E of Rec. ITU-T H.264 | ISO/IEC 14496-10. The relationship between the AVC `time_scale` and the STC shall be defined by the parameters N and K in this descriptor as follows.

$$time\_scale = \frac{(N \times system\_clock\_frequency)}{K}$$

where `time_scale` denotes the exact frequency of the AVC time base, with `K` larger than or equal to `N`.

If the `90kHz_flag` is set to '1', then `N` equals 1 and `K` equals 300. If the `90kHz_flag` is set to '0', then the values of `N` and `K` are provided by the coded values of the `N` and `K` fields.

NOTE 1 – This allows mapping of time expressed in units of `time_scale` to 90-kHz units, as needed for the calculation of PTS and DTS timestamps, for example in decoders for AVC access units for which no PTS or DTS is encoded in the PES header.

**num\_units\_in\_tick** – Coded exactly in the same way as the `num_units_in_tick` field in VUI parameters in Annex E of Rec. ITU-T H.264 | ISO/IEC 14496-10. The information provided by this field shall apply to the entire AVC video stream to which the AVC timing and HRD descriptor is associated.

**fixed\_frame\_rate\_flag** – Coded exactly in the same way as the `fixed_frame_rate_flag` in VUI parameters in Annex E of Rec. ITU-T H.264 | ISO/IEC 14496-10. When this flag is set to '1', it indicates that the coded frame rate is constant within the associated AVC video stream. When this flag is set to '0', no information about the frame rate of the associated AVC video stream is provided in this descriptor.

**temporal\_poc\_flag** – When the `temporal_poc_flag` is set to '1' and the `fixed_frame_rate_flag` is set to '1', then the associated AVC video stream shall carry Picture Order Count (POC) information (`PicOrderCnt`) whereby pictures are counted in units of  $\Delta t_{fi,dpb}(n)$ , where  $\Delta t_{fi,dpb}(n)$  is specified in equation E-10 of Rec. ITU-T H.264 | ISO/IEC 14496-10. When the `temporal_poc_flag` is set to '0', no information is conveyed regarding any potential relationship between the POC information in the AVC video stream and time.

NOTE 2 – This reduces the overhead necessary to signal timing for each access unit. An effective PTS and DTS can be calculated for access units for which no explicit PTS/DTS is carried. Repetition of most recently presented field of the appropriate parity (or frame) is implied when the difference between the PTSs of the current and the next picture is greater than  $2 \times \Delta t_{fi,dpb}$  (or greater than  $\Delta t_{fi,dpb}$  when `frame_mbs_only_flag` is equal to 1).

**picture\_to\_display\_conversion\_flag** – This 1-bit field when set to '1' indicates that the associated AVC video stream may carry display information on coded pictures by providing the `pic_struct` field in picture\_timing SEI messages (see Annex D of Rec. ITU-T H.264 | ISO/IEC 14496-10) and/or by providing the Picture Order Count (POC) information (`PicOrderCnt`), whereby pictures are counted in units of  $\Delta t_{fi,dpb}(n)$  (see also the semantics of `temporal_poc_flag`), so that timing information for a successive AVC access unit can be derived from the previous picture in decoding or presentation order.

When the `picture_to_display_conversion_mode_flag` is set to '0', then picture timing SEI messages in the AVC video stream, if present, shall not contain the `pic_struct` field, and hence the `pic_struct_present_flag` shall be set to '0' in the VUI parameters in the AVC video stream.

## 2.6.68 MPEG-2 AAC audio descriptor

For individual ISO/IEC 13818-7 streams directly carried in PES packets, the MPEG-2 AAC audio descriptor defined in Table 2-94 provides basic information for identifying the coding parameters of such audio elementary streams.

Table 2-94 – MPEG-2 AAC\_audio\_descriptor

Syntax	No. of bits	Mnemonic
MPEG-2_AAC_audio_descriptor () {		
<b>descriptor_tag</b>	8	<b>uimsbf</b>
<b>descriptor_length</b>	8	<b>uimsbf</b>
<b>MPEG-2_AAC_profile</b>	8	<b>uimsbf</b>
<b>MPEG-2_AAC_channel_configuration</b>	8	<b>uimsbf</b>
<b>MPEG-2_AAC_additional_information</b>	8	<b>uimsbf</b>
}		

## 2.6.69 Semantic definition of fields in MPEG-2 AAC audio descriptor

**MPEG-2\_AAC\_profile** – This 8-bit field indicates the AAC profile according to the index in Table 31 of ISO/IEC 13818-7:2006.

**MPEG-2\_AAC\_channel\_configuration** – This 8-bit field indicates the number and configuration of audio channels presented to the listener by the AAC decoder for the specified program. Values in the range from 1 to 6 indicate number and configuration of audio channels as given for "Default bitstream index number" in Table 42 of ISO/IEC 13818-7:2006. All other values indicate that the number and configuration of audio channels is undefined.

**MPEG-2\_AAC\_additional\_information** – This 8-bit field indicates whether or not bandwidth extension data as defined in ISO/IEC 13818-7:2006 is embedded in the AAC bitstream according to Table 2-95.

Table 2-95 – MPEG-2\_AAC\_additional\_information field values

Value	Description
0x00	AAC data according to ISO/IEC 13818-7:2006
0x01	AAC data with Bandwidth Extension data present according to ISO/IEC 13818-7:2006
0x02 .. 0xFF	Reserved

2.6.70 MPEG-4 text descriptor

The MPEG-4 text descriptor (see Table 2-96) carries textConfig() specified in ISO/IEC 14496-17 for the associated ISO/IEC 14496-17 text stream, thereby providing basic information needed for the decoding of the associated ISO/IEC 14496-17 stream. For each ISO/IEC 14496-17 text stream carried in a Rec. ITU-T H.222.0 | ISO/IEC 13818-1 stream, the MPEG-4 text descriptor shall be included in the PMT or in the PSM, if PSM is present in the program stream.

Table 2-96 – MPEG-4 text descriptor

Syntax	No. of bits	Mnemonic
MPEG-4_text_descriptor () { <b>descriptor_tag</b> <b>descriptor_length</b> textConfig() }	8 8	<b>uimsbf</b> <b>uimsbf</b>

2.6.71 Semantic definition of fields in MPEG-4 text descriptor

**textConfig()** – This shall carry the TextConfig() of the associated ISO/IEC 14496-17 text stream, as defined in ISO/IEC 14496-17.

2.6.72 MPEG-4 audio extension descriptor

The MPEG-4 audio extension descriptor (see Table 2-97) carries zero or more audioProfileLevelIndication fields and zero or one audioSpecificConfig() field, both encoded as specified in ISO/IEC 14496-3. Note that for each ISO/IEC 14496-3 audio stream carried in a Rec. ITU-T H.222.0 | ISO/IEC 13818-1 stream, it is required that the MPEG-4 audio descriptor be included in the PMT or in the PSM, if PSM is present in the program stream, while the MPEG-4 audio extension descriptor may be present too, providing additional information. If in the MPEG-4 audio descriptor the MPEG-4\_audio\_profile\_and\_level field is encoded with the value 0xFF, indicating that the audio profile and level is not specified in the MPEG-4 audio descriptor, then the MPEG-4 audio extension descriptor shall be present in the same PMT or PSM as the MPEG-4 audio descriptor. Note that this descriptor allows to provide the audioSpecificConfig out of band, so as to allow receivers to retrieve information about the associated audio stream without accessing the stream itself. The descriptor also allows to associate an audioSpecificConfig to an audio stream.

Table 2-97 – MPEG-4 audio extension descriptor

Syntax	No. of bits	Mnemonic
MPEG-4_audio_extension_descriptor () { <b>descriptor_tag</b> <b>descriptor_length</b> <b>ASC_flag</b> <b>reserved</b> <b>num_of_loops</b> for (i=0; i<num_of_loops; i++) { <b>audioProfileLevelIndication</b> } if (ASC_flag == '1') { <b>ASC_size</b> audioSpecificConfig() } }	8 8 1 3 4 8	<b>uimsbf</b> <b>uimsbf</b> <b>bslbf</b> <b>bslbf</b> <b>uimsbf</b> <b>uimsbf</b>

2.6.73 Semantic definition of fields in MPEG-4 audio extension descriptor

**ASC\_flag** – A one-bit flag signalling the presence of the ASC\_size field in this descriptor.

**num\_of\_loops** – A 4-bit field specifying the number of immediately following audioprofileLevelIndication fields in this descriptor. This field may be encoded with the value zero.

**audioProfileLevelIndication** – The audio profile and level of the associated ISO/IEC 14496-3 audio stream, encoded as specified for the audioprofileLevelIndication field in 1.5.2.1 in ISO/IEC 14496-3. Note that a single ISO/IEC 14496-3 audio stream may comply to more than one audio profile and level, and that this descriptor is designed to convey up to 15 different audioprofileLevelIndication values.

**ASC\_size** – The number of bytes of the immediately following AudioSpecificConfig().

**audioSpecificConfig()** – The audioSpecificConfig() of the associated ISO/IEC 14496-3 audio stream, as specified in 1.6.2.1 in ISO/IEC 14496-3.

#### 2.6.74 Auxiliary video stream descriptor

The auxiliary video stream descriptor (see Table 2-98) specifies parameters for the decoding and interpretation of the auxiliary video stream to which the descriptor is associated. For each auxiliary video stream carried in a Rec. ITU-T H.222.0 | ISO/IEC 13818-1 stream, the auxiliary video stream descriptor shall be included in the PMT or in the PSM, if PSM is present in the program stream.

**Table 2-98 – Auxiliary video stream descriptor**

Syntax	No. of bits	Mnemonic
Auxiliary_video_stream_descriptor() {		
<b>descriptor_tag</b>	8	<b>uimsbf</b>
<b>descriptor_length</b>	8	<b>uimsbf</b>
<b>aux_video_codedstreamtype</b>	8	<b>uimsbf</b>
si_rbsp(descriptor_length-1)		
}		

#### 2.6.75 Semantic definition of fields in auxiliary video stream descriptor

**aux\_video\_codedstreamtype** – An 8-bit unsigned integer that indicates the compression coding type of the auxiliary video stream. The value of aux\_video\_codedstreamtype shall match one of the stream types defined in Table 2-34 for video (for instance 0x02, 0x10 or 0x1B). In order to convey additional information such as profile/level, a descriptor that corresponds to the aux\_video\_codedstreamtype may also be included in the PMT or in the PSM, if PSM is present in the program stream, for the auxiliary video data stream.

NOTE – For example, if the auxiliary video is encoded using Rec. ITU-T H.264 | ISO/IEC 14496-10 Video, then the value of aux\_video\_codedstreamtype is 0x1B and an AVC video descriptor (descriptor\_tag = 40) can be optionally included.

**si\_rbsp()** – Supplemental information RBSP as defined in ISO/IEC 23002-3. It shall contain at least one auxiliary video supplemental information (AVSI) message (also defined in ISO/IEC 23002-3). The type of auxiliary video is inferred from si\_rbsp(). The total size of si\_rbsp() shall not exceed 254 bytes.

#### 2.6.76 SVC extension descriptor

For video sub-bitstreams of AVC video streams conforming to one or more profiles defined in Annex G of Rec. ITU-T H.264 | ISO/IEC 14496-10, the SVC extension descriptor (see Table 2-99) provides information about the AVC video stream resulting from re-assembling (up to) the associated video sub-bitstream and provides information about scalability and re-assembly of the associated video sub-bitstream. There may be one SVC extension descriptor associated with any of the video sub-bitstreams of an AVC video stream conforming to one or more profiles defined in Annex G of Rec. ITU-T H.264 | ISO/IEC 14496-10.

Table 2-99 – SVC extension descriptor

Syntax	No. of bits	Mnemonic
SVC_extension_descriptor() {		
<b>descriptor_tag</b>	<b>8</b>	<b>uimsbf</b>
<b>descriptor_length</b>	<b>8</b>	<b>uimsbf</b>
<b>width</b>	<b>16</b>	<b>uimsbf</b>
<b>height</b>	<b>16</b>	<b>uimsbf</b>
<b>frame_rate</b>	<b>16</b>	<b>uimsbf</b>
<b>average_bitrate</b>	<b>16</b>	<b>uimsbf</b>
<b>maximum_bitrate</b>	<b>16</b>	<b>uimsbf</b>
<b>dependency_id</b>	<b>3</b>	<b>bslbf</b>
<b>reserved</b>	<b>5</b>	<b>bslbf</b>
<b>quality_id_start</b>	<b>4</b>	<b>bslbf</b>
<b>quality_id_end</b>	<b>4</b>	<b>bslbf</b>
<b>temporal_id_start</b>	<b>3</b>	<b>bslbf</b>
<b>temporal_id_end</b>	<b>3</b>	<b>bslbf</b>
<b>no_sei_nal_unit_present</b>	<b>1</b>	<b>bslbf</b>
<b>reserved</b>	<b>1</b>	<b>bslbf</b>
}		

### 2.6.77 Semantic definition of fields in SVC extension descriptor

**width** – This 16-bit field indicates the maximum image width resolution, in pixels of the re-assembled AVC video stream.

**height** – This 16-bit field indicates the maximum image height resolution, in pixels of the re-assembled AVC video stream.

**frame\_rate** – This 16-bit field indicates the maximum frame rate, in frames/256 seconds of the re-assembled AVC video stream.

**average\_bitrate** – This 16-bit field indicates the average bit rate, in kbit per second, of the re-assembled AVC video stream.

**maximum\_bitrate** – This 16-bit field indicates the maximum bit rate, in kbit per second, of the re-assembled AVC video stream.

**dependency\_id** – This 3-bit field indicates the value of `dependency_id` associated with the video sub-bitstream.

**quality\_id\_start** – This 4-bit field indicates the minimum value of the `quality_id` of the NAL unit header syntax element of all the NAL units contained in the associated video sub-bitstream.

**quality\_id\_end** – This 4-bit field indicates the maximum value of the `quality_id` of the NAL unit header syntax element of all the NAL units contained in the associated video sub-bitstream.

**temporal\_id\_start** – This 3-bit field indicates the minimum value of the `temporal_id` of the NAL unit header syntax element of all the NAL units contained in the associated video sub-bitstream.

**temporal\_id\_end** – This 3-bit field indicates the maximum value of the `temporal_id` of the NAL unit header syntax element of all the NAL units contained in the associated video sub-bitstream.

**no\_sei\_nal\_unit\_present** – This 1-bit flag when set to '1' indicates that no SEI NAL units are present in the associated video sub-bitstream.

NOTE – In case the `no_sei_nal_unit_present` flag is set to '1' for all SVC video sub-bitstreams and is not set to '1' or not present for the AVC video sub-bitstream of SVC, any SEI NAL units, if present, are included in the AVC video sub-bitstream of SVC. If the SVC extension descriptor is absent for all video sub-bitstreams, SEI NAL units may be present in any SVC dependency representation of an SVC video sub-bitstream, and may require re-ordering to the order of NAL units within an access unit as defined in Rec. ITU-T H.264 | ISO/IEC 14496-10 before access unit re-assembling.

### 2.6.78 MVC extension descriptor

For MVC video sub-bitstreams of AVC video streams conforming to one or more profiles defined in Annex H of Rec. ITU-T H.264 | ISO/IEC 14496-10, the MVC extension descriptor (see Table 2-100) provides information about the AVC video stream resulting from reassembling (up to) the associated MVC video sub-bitstream and provides information about the contained MVC video sub-bitstream and for the reassembly of the associated MVC video sub-bitstream. There may be one MVC extension descriptor associated with any of the MVC video sub-bitstreams (with `stream_type` equal to 0x20) of an AVC video stream conforming to one or more profiles defined in Annex H of Rec. ITU-T H.264 |

ISO/IEC 14496-10. When the MVC video sub-bitstream is an MVC base view sub-bitstream, the MVC extension descriptor shall be present in the associated PMT or PSM for stream\_type equal to 0x1B.

This descriptor can also be used by applications that require association between stereoscopic MVC views and left or right eye using the syntax elements 'view\_association\_not\_present' and 'base\_view\_is\_left\_eyeview'.

**Table 2-100 – MVC extension descriptor**

Syntax	No. of bits	Mnemonic
MVC_extension_descriptor() {		
<b>descriptor_tag</b>	<b>8</b>	<b>uimsbf</b>
<b>descriptor_length</b>	<b>8</b>	<b>uimsbf</b>
<b>average_bit_rate</b>	<b>16</b>	<b>uimsbf</b>
<b>maximum_bitrate</b>	<b>16</b>	<b>uimsbf</b>
<b>view_association_not_present</b>	<b>1</b>	<b>bslbf</b>
<b>base_view_is_left_eyeview</b>	<b>1</b>	<b>bslbf</b>
<b>reserved</b>	<b>2</b>	<b>bslbf</b>
<b>view_order_index_min</b>	<b>10</b>	<b>bslbf</b>
<b>view_order_index_max</b>	<b>10</b>	<b>bslbf</b>
<b>temporal_id_start</b>	<b>3</b>	<b>bslbf</b>
<b>temporal_id_end</b>	<b>3</b>	<b>bslbf</b>
<b>no_sei_nal_unit_present</b>	<b>1</b>	<b>bslbf</b>
<b>no_prefix_nal_unit_present</b>	<b>1</b>	<b>bslbf</b>
}		

#### 2.6.79 Semantics of fields in MVC extension descriptor

**average\_bitrate** – This 16-bit field indicates the average bit rate, in kbits per second, of the re-assembled AVC video stream. When set to 0, the average bit rate is not indicated.

**maximum\_bitrate** – This 16-bit field indicates the maximum bit rate, in kbits per second, of the re-assembled AVC video stream. When set to 0, the maximum bit rate is not indicated.

**view\_association\_not\_present** – This 1-bit flag when set to '0' indicates that the syntax element base\_view\_is\_left\_eyeview signals the association between base view and left or right eye. When this flag is set to '1' no such association is signalled.

**base\_view\_is\_left\_eyeview** – This flag shall be set to '1' when the view\_association\_not\_present\_flag is set to '1' and no view association is conveyed in the descriptor. When the view\_association\_not\_present\_flag is set to '0' and this flag is set to '1', it indicates that the base view is associated with the left eye view (or enhancement view is associated with the right eye view). When the view\_association\_not\_present\_flag is set to '0' and this flag is set to '0', it indicates that the base view is associated with the right eye view (or enhancement view is associated with the left eye view).

**view\_order\_index\_min** – This 10-bit field indicates the minimum value of the view order index of all the NAL units contained in the associated MVC video sub-bitstream.

**view\_order\_index\_max** – This 10-bit field indicates the maximum value of the view order index of all the NAL units contained in the associated MVC video sub-bitstream.

**temporal\_id\_start** – This 3-bit field indicates the minimum value of the temporal\_id of the NAL unit header syntax element of all the NAL units contained in the associated MVC video sub-bitstream.

**temporal\_id\_end** – This 3-bit field indicates the maximum value of the temporal\_id of the NAL unit header syntax element of all the NAL units contained in the associated MVC video sub-bitstream.

**no\_sei\_nal\_unit\_present** – This 1-bit flag when set to '1' indicates that no SEI NAL units are present in the associated video sub-bitstream.

NOTE – In case the no\_sei\_nal\_unit\_present flag is set to '1' for all MVC video sub-bitstreams and is not set to '1' or not present for the AVC video sub-bitstream of MVC, any SEI NAL units, if present, are included in the AVC video sub-bitstream of MVC. If the MVC extension descriptor is absent for all MVC video sub-bitstreams, SEI NAL units may be present in any MVC view-component subset of an MVC video sub-bitstream, and may require re-ordering to the order of NAL units within an access unit as defined in Rec. ITU-T H.264 | ISO/IEC 14496-10 before access unit re-assembling.

**no\_prefix\_nal\_unit\_present** – This 1-bit flag when set to '1' indicates that no prefix NAL units are present in either the AVC video sub-bitstream of MVC or MVC video sub-bitstreams. When this bit is set to '0', it indicates that prefix NAL units are present in the AVC video sub-bitstream of MVC only.

**2.6.80 J2K video descriptor**

For J2K video elementary streams conforming to one or more profiles defined in Rec. ITU-T T.800 | ISO/IEC 15444-1, the J2K video descriptor (see Table 2-101) provides information that may be present in each J2K access unit as well as for the J2K video sequence. In addition, it provides information to signal J2K still pictures. This descriptor shall be included for each J2K video elementary stream component in the PMT with stream\_type equal to 0x21.

**Table 2-101 – J2K video descriptor**

Syntax	No. of bits	Mnemonic
J2K_video_descriptor() {		
<b>descriptor_tag</b>	8	uimsbf
<b>descriptor_length</b>	8	uimsbf
<b>extended_capability_flag</b>	1	bslbf
<b>profile_and_level</b>	15	bslbf
<b>horizontal_size</b>	32	uimsbf
<b>vertical_size</b>	32	uimsbf
<b>max_bit_rate</b>	32	uimsbf
<b>max_buffer_size</b>	32	uimsbf
<b>DEN_frame_rate</b>	16	bslbf
<b>NUM_frame_rate</b>	16	bslbf
if (extended_capability_flag == '1') {		
<b>stripe_flag</b>	1	bslbf
<b>block_flag</b>	1	bslbf
<b>mdm_flag</b>	1	bslbf
<b>reserved (all bits to be set to '0')</b>	5	bslbf
} else {		
<b>color_specification</b>	8	bslbf
}		
<b>still_mode</b>	1	bslbf
<b>interlaced_video</b>	1	bslbf
<b>reserved</b>	6	bslbf
if (extended_capability_flag == '1') {		
<b>colour_primaries</b>	8	uimsbf
<b>transfer_characteristics</b>	8	uimsbf
<b>matrix_coefficients</b>	8	uimsbf
<b>video_full_range_flag</b>	1	bslbf
<b>reserved</b>	7	bslbf
if (stripe_flag == '1') {		
<b>strp_max_idx</b>	8	uimsbf
<b>strp_height</b>	16	uimsbf
}		
if (block_flag == '1') {		
<b>full_horizontal_size</b>	32	uimsbf
<b>full_vertical_size</b>	32	uimsbf
<b>blk_width</b>	16	uimsbf
<b>blk_height</b>	16	uimsbf
<b>max_blk_idx_h</b>	8	uimsbf
<b>max_blk_idx_v</b>	8	uimsbf
<b>blk_idx_h</b>	8	uimsbf
<b>blk_idx_v</b>	8	uimsbf
}		
} if (mdm_flag == '1') {		
<b>X_c0, Y_c0, X_c1, Y_c1, X_c2, Y_c2</b>	16x6	uimsbf
<b>X_wp</b>	16	uimsbf
<b>Y_wp</b>	16	uimsbf
<b>L_max</b>	32	uimsbf
<b>L_min</b>	32	uimsbf

Table 2-101 – J2K video descriptor

Syntax	No. of bits	Mnemonic
<b>MaxCLL</b>	<b>16</b>	<b>uimsbf</b>
<b>MaxFALL</b>	<b>16</b>	<b>uimsbf</b>
<pre> } } for (i=0; i&lt;N; i++) {     <b>private_data_byte</b> } } </pre>	<b>8</b>	<b>bslbf</b>

### 2.6.81 Semantics of fields in J2K video descriptor

**extended\_capability\_flag** – This 1-bit field indicates that the J2K video stream uses extended color specification (through three bytes defining the chromaticity parameters, as described below), and that it might have one or several of the following capabilities enabled: stripes (through the J2K stripe mode), blocks (through the J2K block mode), or inclusion of mastering display metadata. The exact list of enabled capabilities is set through subsequent flags in the video descriptor (see below).

**profile\_and\_level** – This 15-bit field shall correspond to the 15 least significant bits of the 2-bytes Rsiz value included in all J2K codestream main headers of this J2K video stream. Rsiz values that are defined in Table A.10 of Rec. ITU-T T.800 | ISO/IEC 15444-1 and do set to '0' their most significant bit are allowed.

NOTE – the combination of the `extended_capability_flag` and the `profile_and_level` field ensures backward and forward compatibility with legacy devices conforming to previous versions of this Recommendation | International Standard. Having the `extended_capability_flag` set to '1' leads indeed to a 16-bit value outside the range accepted by previous versions of this Recommendation | International Standard. This way, J2K video streams with extended capabilities can be unequivocally identified by both legacy and new devices.

**horizontal\_size** – This 32-bit field indicates the horizontal size of the frame (for progressive) or field (for interlaced) comprised in each J2K access unit. If J2K block mode is enabled, this frame or field corresponds to a spatial rectangular block of the entire video frame or field. It shall be coded the same as the Xsiz parameter found in all J2K codestream main headers of this J2K video stream, as defined in Annex A of Rec. ITU-T T.800 | ISO/IEC 15444-1.

**vertical\_size** – This 32-bit field indicates the vertical size of the frame (for progressive) or field (for interlaced) comprised in each J2K access unit. If J2K block mode is enabled, this frame or field corresponds to a spatial rectangular block of the entire video frame or field. If J2K stripe mode is disabled, it shall be coded the same as the Ysiz parameter found in all J2K codestream main headers of this J2K video stream. If J2K stripe mode is enabled, it shall be coded as the sum of the Ysiz parameters found in all J2K codestreams composing the frame (for progressive) or a field (for interlaced) comprised in each J2K access unit. Ysiz parameters are defined in Annex A of Rec. ITU-T T.800 | ISO/IEC 15444-1.

**max\_bit\_rate** – This field may be coded the same as the `brat_max_br` field specified in Table S.1 and shall not exceed the maximum compressed bit rate value for the profile and level specified in Table S.2. This field shall be set appropriately and signalled when `profile_and_level = '000 0011 0000 0111'`, where no maximum bit rate is specified.

**max\_buffer\_size** – This field shall not exceed the Maximum buffer size value for the profile and level specified in Table S.2. When `profile_and_level = '000 0011 0000 0111'`, the `max_buffer_size` shall be set appropriately and shall not exceed  $(\text{max\_bit\_rate}/1.60E5)$ , where `max_bit_rate` is expressed in bit/s.

**DEN\_frame\_rate** – This field shall be coded the same as `frat_denominator` field specified in Table S.1 (see Annex S).

**NUM\_frame\_rate** – This field shall be coded the same as `frat_numerator` field specified in Table S.1 (see Annex S).

NOTE – J2K frame rate is derived from the `DEN_frame_rate` and `NUM_frame_rate` values. Table 2-102 lists examples of typical broadcast frame rates with associated values of `DEN_frame_rate` and `NUM_frame_rate`.

Table 2-102 – Example frame rates based on DEN\_frame\_rate and NUM\_frame\_rate values

DEN_frame_rate	NUM_frame_rate	Frame rate ratio (decimal representation)	Frame rate
0000 0000 0000 0000			Forbidden
0000 0011 1110 1001	0101 1101 1100 0000	24 000 / 1001	23.976
0000 0000 0000 0001	0000 0000 0001 1000	24 / 1	24.0
0000 0000 0000 0001	0000 0000 0001 1001	25 / 1	25.0
0000 0011 1110 1001	0111 0101 0011 0000	30 000 / 1001	29.97
0000 0000 0000 0001	0000 0000 0001 1110	30 / 1	30.0
0000 0000 0000 0001	0000 0000 0011 0010	50 / 1	50.0
0000 0011 1110 1001	1110 1010 0110 0000	60 000 / 1001	59.94
0000 0000 0000 0001	0000 0000 0011 1100	60 / 1	60.00

**stripe\_flag** – This 1-bit field is included only if the extended\_capability\_flag is set to '1'. It indicates whether the J2K video stream has J2K stripe mode enabled. When this flag is set to '1' the J2K access unit elementary stream header (see Table S.1) shall not include the syntax element j2k\_tcod, shall include the syntax element j2k\_strp, and the corresponding J2K access unit shall be made of a succession of J2K stripes. When this flag is set to '0', the J2K access unit elementary stream header shall include the syntax element j2k\_tcod, shall not include the syntax element j2k\_strp, and the corresponding J2K access unit shall be made of one J2K codestream in case of progressive content and two J2K codestreams in case of interlaced content.

**block\_flag** – This 1-bit field is included only if the extended\_capability\_flag is set to '1'. When set to '1', it indicates that the J2K video stream has J2K block mode enabled, meaning that this J2K video stream actually corresponds to a spatial rectangular block of the full video stream. Subdivision of each frame into rectangular independent blocks is further defined in Section S.3. When set to '0', then the associated J2K video stream shall not have J2K block mode enabled.

**mdm\_flag** – This 1-bit field is included only if the extended\_capability\_flag is set to '1'. When set to '1', it indicates that the J2K video descriptor contains the characteristics of the Mastering Display Metadata, as described in SMPTE ST 2086:2014 (see below corresponding fields). When set to '0', then the J2K video descriptor shall not contain the characteristics of the Mastering Display Metadata.

**color\_specification** – This 8-bit field is included only if the extended\_capability\_flag is set to '0' and corresponds to the legacy color specification method. It shall be coded the same as the bcol\_colcr 8-bit field of the j2k\_bcol box as specified in Table S.1 (see Annex S).

**still\_mode** – This 1-bit field, when set to '1', indicates that the J2K video stream may include J2K still pictures. When set to '0', then the associated J2K video stream shall not contain J2K still pictures.

**interlaced\_video** – This 1-bit field indicates whether the J2K video stream contains interlaced video. When this flag is set to '1' the J2K access unit elementary stream header (see Table S.1) shall include the syntax elements brat\_auf2, fiel\_box\_code, fiel\_fic and fiel\_flo. When this flag is set to '0', these syntax elements shall not be present in the J2K access unit elementary stream header.

**color primaries, transfer characteristics, matrix coefficients, video\_full\_range\_flag** – These four fields (three 8-bit fields and one 1-bit field) are included only if the extended\_capability\_flag is set to '1' and correspond to a color specification method allowing a broader set of color code points than the legacy method (see color\_specification field above). These fields shall be coded according to the semantics with the same name defined in Rec. ITU-T H.273 | ISO/IEC 23001-8.

**strp\_max\_idx** – This 8-bit field is included only if J2K stripe mode is enabled. It shall be in the range 0x01 .. 0xff and indicates the maximum value of the stripe index. It corresponds to the number of stripes in the block/field/frame, minus one. Value 0x00 is forbidden as a minimum of 2 stripes is required (otherwise J2K stripe mode shall be disabled).

**strp\_height** – This 16-bit field is included only if J2K stripe mode is enabled. It indicates the default vertical size of a stripe. Depending on the vertical\_size field value, the last stripe might have a different height, as detailed in S.4.

**full\_horizontal\_size** – This 32-bit field is included only if J2K block mode is enabled. It indicates the horizontal size of the entire video frame of this J2K video stream.

**full\_vertical\_size** – This 32-bit field is included only if J2K block mode is enabled. It indicates the vertical size of the entire video frame of this J2K video stream.

**blk\_width** – This 16-bit field is included only if J2K block mode is enabled. It indicates the default width of a J2K block. Depending on the full\_horizontal\_size field value, the last block of a row might have a different width, as detailed in S.3.

**blk\_height** – This 16-bit field is included only if J2K block mode is enabled. It indicates the default height of a J2K block. Depending on the full\_vertical\_size field value, the last block of a column might have a different height, as detailed in S.3.

**max\_blk\_idx\_h** – This 8-bit field is included only if J2K block mode is enabled and indicates the maximum value of the horizontal block index for this video frame. It corresponds to the total number of blocks in the horizontal direction, minus one.

**max\_blk\_idx\_v** – This 8-bit field is included only if J2K block mode is enabled and indicates the maximum value of the vertical block index for this video frame. It corresponds to the total number of blocks in the vertical direction, minus one.

**blk\_idx\_h** – This 8-bit field is included only if J2K block mode is enabled and indicates the horizontal block index of the current block.

**blk\_idx\_v** – This 8-bit field is included only if J2K block mode is enabled and indicates the vertical block index of the current block.

The following fields X\_c0, Y\_c0, X\_c1, Y\_c1, X\_c2, Y\_c2, X\_wp, Y\_wp, L\_max and L\_min correspond to the fields defined in SMPTE ST2086:2014 "Mastering Display Color Volume Metadata Supporting High Luminance and Wide Color Gamut Images". The fields MaxFALL and MaxCLL correspond to the fields defined in ANSI/CTA 861-G:2016 "A DTV Profile for Uncompressed High Speed Digital Interfaces". If these 12 fields have unknown values at the time of generating the stream, they shall not be included in the descriptor and the mdm\_flag shall be set to '0'.

**X\_c0, Y\_c0, X\_c1, Y\_c1, X\_c2, Y\_c2** – These 16-bit fields are included only if the mdm\_flag is set to '1'. They specify the normalized x and y chromaticity coordinates of the colour primary components of the mastering display in increments of 0.00002, according to the CIE 1931 definition of x and y as specified in ISO 11664-1 (see also ISO 11664-3 and CIE 15). For describing mastering displays that use red, green, and blue colour primaries, it is suggested that index value c0 should correspond to the green primary, c1 should correspond to the blue primary, and c2 should correspond to the red colour primary. The values of these 6 fields shall be in the range of 0 to 50 000, inclusive.

**X\_wp and Y\_wp** – These 16-bit fields are included only if the mdm\_flag is set to '1'. They specify the normalized x and y chromaticity coordinates of the white point of the mastering display in normalized increments of 0.00002, according to the CIE 1931 definition of x and y as specified in ISO 11664-1 (see also ISO 11664-3 and CIE 15). The values of X\_wp and Y\_wp shall be in the range of 0 to 50 000.

**L\_max and L\_min** – These 32-bit fields are included only if the mdm\_flag is set to '1'. They specify the nominal maximum and minimum display luminance, respectively, of the mastering display in units of 0.0001 candelas per square metre. L\_min shall be less than L\_max. At minimum luminance, the mastering display is considered to have the same nominal chromaticity as the white point.

**MaxCLL** – This 16-bit field is included only if the mdm\_flag is set to '1'. It specifies the Maximum Content Light Level and corresponds to the brightest pixel in the entire stream, in units of 1 cd/m<sup>2</sup>, where 0x0001 represents 1 cd/m<sup>2</sup> and 0xFFFF represents 65535 cd/m<sup>2</sup>. It shall be calculated according to Annex P Calculation of MaxCLL and MaxFALL section P.1 in ANSI/CTA 861-G:2016 "A DTV Profile for Uncompressed High Speed Digital Interfaces".

**MaxFALL** – This 16-bit field is included only if the mdm\_flag is set to '1'. It specifies the Maximum Frame Average Light Level and corresponds to the highest frame average brightness per frame in the entire stream, in units of 1 cd/m<sup>2</sup>, where 0x0001 represents 1 cd/m<sup>2</sup> and 0xFFFF represents 65535 cd/m<sup>2</sup>. It shall be calculated according to Annex P Calculation of MaxCLL and MaxFALL section P.2 in ANSI/CTA 861-G:2016 "A DTV Profile for Uncompressed High Speed Digital Interfaces".

If for some reason the MaxCLL and/or MaxFALL values are unknown, the value 0x0000 shall be used.

## 2.6.82 MVC operation point descriptor

The MVC operation point descriptor (see Table 2-103) provides a method to indicate profile and level for one or more operation points each constituted by a set of one or more MVC video sub-bitstreams. If present, the MVC operation point descriptor shall be included in the group of data elements following immediately the program\_info\_length field in the program\_map\_section. If an MVC operation point descriptor is present within a program description, at least one hierarchy descriptor shall be present for each MVC video sub-bitstream present in the same program.

NOTE – In order to indicate different profiles, one MVC operation point descriptor per profile is needed.

Table 2-103 – MVC operation point descriptor

Syntax	No. of bits	Mnemonic
MVC_operation_point_descriptor() {		
<b>descriptor_tag</b>	8	<b>uimsbf</b>
<b>descriptor_length</b>	8	<b>uimsbf</b>
<b>profile_idc</b>	8	<b>uimsbf</b>
<b>constraint_set0_flag</b>	1	<b>bslbf</b>
<b>constraint_set1_flag</b>	1	<b>bslbf</b>
<b>constraint_set2_flag</b>	1	<b>bslbf</b>
<b>constraint_set3_flag</b>	1	<b>bslbf</b>
<b>constraint_set4_flag</b>	1	<b>bslbf</b>
<b>constraint_set5_flag</b>	1	<b>bslbf</b>
<b>AVC_compatible_flags</b>	2	<b>bslbf</b>
<b>level_count</b>	8	<b>uimsbf</b>
for ( i = 0; i < level_count; i++ ) {		
<b>level_idc</b>	8	<b>uimsbf</b>
<b>operation_points_count</b>	8	<b>uimsbf</b>
for ( j = 0; j < operation_points_count; j++ ) {		
<b>reserved</b>	5	<b>bslbf</b>
<b>applicable_temporal_id</b>	3	<b>uimsbf</b>
<b>num_target_output_views</b>	8	<b>uimsbf</b>
<b>ES_count</b>	8	<b>uimsbf</b>
for ( k = 0; k < ES_count; k++ ) {		
<b>reserved</b>	2	<b>bslbf</b>
<b>ES_reference</b>	6	<b>uimsbf</b>
}		
}		
}		
}		

2.6.83 Semantic definition of fields in MVC operation point descriptor

**profile\_idc** – This 8-bit field indicates the profile, as defined in Rec. ITU-T H.264 | ISO/IEC 14496-10, of all operation points described within this descriptor for the MVC bitstream.

**constraint\_set0\_flag, constraint\_set1\_flag, constraint\_set2\_flag, constraint\_set3\_flag, constraint\_set4\_flag, constraint\_set5\_flag** – These fields shall be coded according to the semantics for these fields defined in Rec. ITU-T H.264 | ISO/IEC 14496-10.

**AVC\_compatible\_flags** – The semantics of AVC\_compatible\_flags are exactly equal to the semantics of the field(s) defined for the 2 bits between the constraint\_set2 flag and the level\_idc field in the sequence parameter set, as defined in Rec. ITU-T H.264 | ISO/IEC 14496-10.

**level\_count** – This 8-bit field indicates the number of levels for which operation points are described.

**level\_idc** – This 8-bit field indicates the level, as defined in Rec. ITU-T H.264 | ISO/IEC 14496-10, of the MVC bitstream for the operation points described by the following groups of data elements.

**operation\_points\_count** – This 8-bit field indicates the number of operation points described by the list included in the following group of data elements.

**applicable\_temporal\_id** – This 3-bit field indicates the highest value of the temporal\_id of the VCL NAL units in the re-assembled AVC video stream.

**num\_target\_output\_views** – This 8-bit field indicates the value of the number of the views, targeted for output for the associated operation point.

**ES\_count** – This 8-bit field indicates the number of ES\_reference values included in the following group of data elements. The elementary streams indicated in the following group of data elements together form an operation point of the MVC video bitstream. The value 0xff is reserved.

**ES\_reference** – This 6-bit field indicates the hierarchy layer index value present in the hierarchy descriptor which identifies a video sub-bitstream.

NOTE – The profile and level for a single operation point, e.g., the entire MVC video bitstream, can be signalled using the AVC video descriptor. Beyond that, MVC allows for decoding different view subsets which can require different profiles and/or levels.

The specification of the MVC operation point descriptor supports the indication of different profiles and levels for multiple operation points.

#### 2.6.84 MPEG2\_stereoscopic\_video\_format\_descriptor

The MPEG2\_stereoscopic\_video\_format\_descriptor (see Table 2-104) may be associated in the PMT for MPEG-2 video components (with stream\_type value equal to 0x02). When present, the descriptor shall be located in the loop following ES\_info\_length field in PMT. When the descriptor is included in the PMT, the associated MPEG-2 video elementary stream shall contain stereoscopic video format information in the user\_data extension as specified in Rec. ITU-T H.262 | ISO/IEC 13818-2:2000/Amd.4. If the descriptor is not included for MPEG-2 video with stream\_type value equal to 0x02, then the associated MPEG-2 video elementary stream may or may not contain stereoscopic video format information.

Table 2-104 – MPEG2\_stereoscopic\_video\_format\_descriptor syntax

Syntax	No. of bits	Format
MPEG2_stereoscopic_video_format_descriptor() {		
<b>descriptor_tag</b>	8	uimsbf
<b>descriptor_length</b>	8	uimsbf
<b>stereo_video_arrangement_type_present</b>	1	bslbf
if (stereo_video_arrangement_type_present) {		
<b>arrangement_type</b>	7	bslbf
}		
else {		
<b>reserved</b>	7	bslbf
}		
}		

#### 2.6.85 Semantic definition of fields in the MPEG2\_stereoscopic\_video\_format\_descriptor

**stereo\_video\_arrangement\_type\_present:** When this bit is set to '1', then the following 7-bits indicate the type of stereo\_video\_format\_type included in the user\_data of associated MPEG-2 video elementary stream. If this bit is set to '0', then no such signalling is made available in this descriptor.

**arrangement\_type:** This field shall be set to the same value as arrangement\_type defined in Table L-1 of Rec. ITU-T H.262 | ISO/IEC 13818-2:2000/Amd.4 and included in the user\_data extension of associated MPEG-2 video elementary stream.

#### 2.6.86 Stereoscopic\_program\_info\_descriptor

Stereoscopic\_program\_info\_descriptor (see Table 2-105) specifies the identification of 2D-only (monoscopic), frame compatible stereoscopic 3D as well as service-compatible stereoscopic 3D services. This descriptor conveys information at a program level and assists decoders determine resources required to support the signalled services. When present, this descriptor shall be included in the loop following program\_info\_length field in the PMT. In addition, when this descriptor is present, stream\_type values and descriptors associated with the video components in the loop following ES\_info\_length in the PMT shall not conflict with the stereoscopic\_service\_type signalled in this descriptor.

Table 2-105 – Stereoscopic\_program\_info\_descriptor syntax

Syntax	No. of bits	Format
Stereoscopic_program_info_descriptor() {		
<b>descriptor_tag</b>	8	uimsbf
<b>descriptor_length</b>	8	uimsbf
<b>reserved</b>	5	bslbf
<b>stereoscopic_service_type</b>	3	bslbf
}		

#### 2.6.87 Semantic definition of fields in the stereoscopic\_program\_info\_descriptor

**descriptor\_length:** This field shall be set to 0x01.

**stereoscopic\_service\_type:** This specifies the type of service that is provided through the associated components such as monoscopic, frame compatible stereoscopic or service-compatible stereoscopic according to Table 2-106.

**Table 2-106 – Stereoscopic\_service\_type values**

Values	Description
'000'	unspecified
'001'	2D-only (monoscopic) service (see Note 1)
'010'	Frame-compatible stereoscopic 3D service
'011'	Service-compatible stereoscopic 3D service (see Note 2)
'100' .. '111'	Rec. ITU-T H.222.0   ISO/IEC 13818-1 reserved

NOTE 1 – 2D-only (monoscopic) service is used in 2D/3D mixed programs based on service-compatible stereoscopic 3D service, i.e., a service that has an arbitrary mixture of 2D and 3D video. 2D video can be coded independently using either MPEG-2 or AVC video to maintain stability of 3DTV broadcasting system.

NOTE 2 – Service-compatible stereoscopic 3D service is based on 'simulcast' of stereoscopic view sequences. Each view of the stereoscopic video sequences can be coded independently using either MPEG-2 or AVC video or any combination thereof. Base view video stream for service-compatible stereoscopic 3D services is signalled using stream\_type value of 0x02 for MPEG-2 video and stream\_type value of 0x1B for AVC video. Additional view video stream for service-compatible stereoscopic 3D services is signalled using stream\_type value of 0x22 for MPEG-2 video and stream\_type value of 0x23 for AVC video.

**2.6.88 Stereoscopic\_video\_info\_descriptor**

The stereoscopic\_video\_info\_descriptor (see Table 2-107) provides information related to service-compatible stereoscopic 3D services that carry left and right view in separate video streams. The two streams are called the "base view video stream" and the "additional view video stream". The base view video stream may be displayed on its own for a 2D video service. If signalled as specified below, the additional view video stream may also be displayed on its own for a 2D video service.

The stereoscopic\_video\_info\_descriptor is located in the loop following ES\_info\_length field in PMT. The stereoscopic\_video\_info\_descriptor shall be included for both the base view video component (stream\_type values 0x02 or 0x1B) and additional view video component (stream\_type values 0x22 or 0x23) in the PMT for programs that support service-compatible stereoscopic 3D video. The stereoscopic\_video\_info\_descriptor should not be associated for components with any other stream\_type values as its meaning is undefined for other stream\_type values.

**Table 2-107 – Stereoscopic\_video\_info\_descriptor syntax**

Syntax	No. of bits	Format
Stereoscopic_video_info_descriptor() {		
<b>descriptor_tag</b>	<b>8</b>	<b>uimsbf</b>
<b>descriptor_length</b>	<b>8</b>	<b>uimsbf</b>
<b>reserved</b>	<b>7</b>	<b>bslbf</b>
<b>base_video_flag</b>	<b>1</b>	<b>bslbf</b>
if (base_video_flag) {		
<b>reserved</b>	<b>7</b>	<b>bslbf</b>
<b>leftview_flag</b>	<b>1</b>	<b>bslbf</b>
} else {		
<b>reserved</b>	<b>7</b>	<b>bslbf</b>
<b>usable_as_2D</b>	<b>1</b>	<b>bslbf</b>
<b>horizontal_upsampling_factor</b>	<b>4</b>	<b>bslbf</b>
<b>vertical_upsampling_factor</b>	<b>4</b>	<b>bslbf</b>
}		
}		

**2.6.89 Semantic definition of fields in the stereoscopic\_video\_info\_descriptor**

**base\_video\_flag:** When the bit is set to '1', it indicates that the video stream is a base video stream. When the bit is set to '0', it indicates that the video stream is an additional view video stream. This bit shall be set to '1' for base view video stream components with stream\_type values of 0x02 and 0x1B and this bit shall be set to '0' for the additional view video stream components with stream\_type values of 0x22 and 0x23.

**leftview\_flag:** When the bit is set to '1', it indicates that the associated video stream component is the left view video stream. When the bit is set to '0', it indicates that the associated video stream component is the right view video stream.

**usable\_as\_2D:** When this bit is set to '1', it indicates that the additional view video stream may also be used for a 2D video service.

**horizontal\_upsampling\_factor and vertical\_upsampling\_factor:** These fields provide higher level information on any upsampling that may be required after the video component is decoded. The values and description of upsampling factors are defined in Table 2-108. These values are informational, and that the definitive values are those in the video elementary stream. When this syntax element is set to '0001' decoders are expected to use the information in the video elementary stream to determine appropriate upsampling factors (if needed).

**Table 2-108 – Upsampling factor values**

Value	Description
'0000'	Forbidden
'0001'	unspecified
'0010'	Coded resolution is same as coded resolution of base view
'0011'	Coded resolution is $\frac{3}{4}$ coded resolution of base view
'0100'	Coded resolution is $\frac{2}{3}$ coded resolution of base view
'0101'	Coded resolution is $\frac{1}{2}$ coded resolution of base view
'0110' .. '1000'	reserved
'1001' .. '1111'	user_private

#### 2.6.90 Extension descriptor

The extension descriptor (see Table 2-109) provides a mechanism to extend the Rec. ITU-T H.222.0 | ISO/IEC 13818-1 descriptor range (see Table 2-45). The descriptors which are based on the extension descriptor are signalled using the extension descriptor with extension\_descriptor\_tag values defined in Table 2-110.

**Table 2-109 – Extension descriptor**

Syntax	No. of bits	Mnemonic
<pre> Extension_descriptor () {     <b>descriptor_tag</b>     <b>descriptor_length</b>     <b>extension_descriptor_tag</b>     if ( extension_descriptor_tag == 0x02 ) {         ObjectDescriptorUpdate()     }     else if ( extension_descriptor_tag == 0x03 ) {         HEVC_timing_and_HRD_descriptor()     }     else if ( extension_descriptor_tag == 0x04 ) {         af_extensions_descriptor ()     }     else if ( extension_descriptor_tag == 0x05 ) {         HEVC_operation_point_descriptor()     }     else if ( extension_descriptor_tag == 0x06 ) {         HEVC_hierarchy_extension_descriptor()     }     else if ( extension_descriptor_tag == 0x07 ) {         Green_extension_descriptor ()     }     else if ( extension_descriptor_tag == 0x08 ) {         MPEG-H_3dAudio_descriptor() </pre>	<p>8</p> <p>8</p> <p>8</p>	<p><b>uimsbf</b></p> <p><b>uimsbf</b></p> <p><b>uimsbf</b></p>

Table 2-109 – Extension descriptor

Syntax	No. of bits	Mnemonic
<pre> } else if ( extension_descriptor_tag == 0x09) {     MPEG-H_3dAudio_config_descriptor() } else if ( extension_descriptor_tag == 0x0A) {     MPEG-H_3dAudio_scene_descriptor() } else if ( extension_descriptor_tag == 0x0B) {     MPEG-H_3dAudio_text_label_descriptor() } else if ( extension_descriptor_tag == 0x0C) {     MPEG-H_3dAudio_multi-stream_descriptor() } else if ( extension_descriptor_tag == 0x0D) {     MPEG-H_3dAudio_drc_loudness_descriptor() } else if ( extension_descriptor_tag == 0x0E) {     MPEG-H_3dAudio_command_descriptor() } else if ( extension_descriptor_tag == 0x0F) {     Quality_extension_descriptor () } else if ( extension_descriptor_tag == 0x10) {     Virtual_segmentation_descriptor () } else if ( extension_descriptor_tag == 0x11) {     timed_metadata_extension_descriptor() } else if ( extension_descriptor_tag == 0x12) {     HEVC_tile_substream_descriptor() } else if ( extension_descriptor_tag == 0x13) {     HEVC_subregion_descriptor() } else if ( extension_descriptor_tag == 0x14) {     JXS_video_descriptor() } else if ( extension_descriptor_tag == 0x15) {     VVC_timing_and_HRD_descriptor() } else if ( extension_descriptor_tag == 0x16) {     EVC_timing_and_HRD_descriptor() } else if ( extension_descriptor_tag == 0x17) {     LCEVC_video_descriptor () } else if ( extension_descriptor_tag == 0x18) {     LCEVC_linkage_descriptor() } </pre>		

STANDARDSISO.COM · Click to view the full PDF of ISO/IEC 13818-1:2023

Table 2-109 – Extension descriptor

Syntax	No. of bits	Mnemonic
<pre> else if ( extension_descriptor_tag == 0x19) {     Media_service_kind_descriptor() } else {     for ( i=0; i&lt;N; i++ ) {         reserved     } } } </pre>	<b>8</b>	<b>bslbf</b>

### 2.6.91 Semantic definition of fields in the extension descriptor

**descriptor\_tag** – The descriptor\_tag is an 8-bit field whose value is defined in Table 2-45.

**descriptor\_length** – The descriptor\_length is an 8-bit field specifying the number of bytes of the descriptor immediately following the descriptor\_length field.

**extension\_descriptor\_tag** – The extension\_descriptor\_tag is an 8-bit field which identifies each descriptor that uses this tag value. See Table 2-109 for the extension\_descriptor\_tag values.

**ObjectDescriptorUpdate()** – This structure is defined in section 8.5.5.2 of ISO/IEC 14496-1.

**HEVC\_timing\_and\_HRD\_descriptor()** – This structure is defined in 2.6.95 and 2.6.96.

**af\_extensions\_descriptor()** – This structure is defined in 2.6.99.

**HEVC\_operation\_point\_descriptor()** – This structure is defined in 2.6.100 and 2.6.101.

**HEVC\_hierarchy\_extension\_descriptor()** – This structure is defined in 2.6.102 and 2.6.103.

**Green\_extension\_descriptor()** – This structure is defined in 2.6.104 and 2.6.105.

**MPEG-H\_3dAudio\_descriptor()** – This structure is defined in 2.6.106 and 2.6.107.

**MPEG-H\_3dAudio\_config\_descriptor()** – This structure is defined in 2.6.108 and 2.6.109.

**MPEG-H\_3dAudio\_scene\_descriptor()** – This structure is defined in 2.6.110 and 2.6.111.

**MPEG-H\_3dAudio\_text\_label\_descriptor()** – This structure is defined in 2.6.112 and 2.6.113.

**MPEG-H\_3dAudio\_multi-stream\_descriptor()** – This structure is defined in 2.6.114 and 2.6.115.

**MPEG-H\_3dAudio\_drc\_loudness\_descriptor()** – This structure is defined in 2.6.116 and 2.6.117.

**MPEG-H\_3dAudio\_command\_descriptor()** – This structure is defined in 2.6.118.

**Quality\_extension\_descriptor()** – This structure is defined in 2.6.119.

**Virtual\_segmentation\_descriptor()** – This structure is defined in 2.6.120 and 2.6.121.

**timed\_metadata\_extension\_descriptor()** – This structure is defined in clause 8.2.3 of ISO/IEC 23001-13.

**HEVC\_tile\_substream\_descriptor()** – This structure is defined in 2.6.122 and 2.6.123.

**HEVC\_subregion\_descriptor()** – This structure is defined in 2.6.125 and 2.6.126.

**JXS\_video\_descriptor()** – This structure is defined in 2.6.127 and 2.6.128.

**VVC\_timing\_and\_HRD\_descriptor()** – This structure is defined in 2.6.131 and 2.6.132.

**EVC\_timing\_and\_HRD\_descriptor()** – This structure is defined in 2.6.135 and 2.6.136.

**LCEVC\_video\_descriptor()** – This structure is defined in 2.6.137 and 2.6.138.

**LCEVC\_linkage\_descriptor()** – This structure is defined in 2.6.139 and 2.6.140.

**Media\_service\_kind\_descriptor()** – This structure is defined in 2.6.141 and 2.6.142.

Table 2-110 – Extension descriptor tag values

Extension_descriptor_tag	TS	PS	Identification
0	n/a	n/a	Reserved
1	n/a	X	Forbidden
2	X	X	ODUpdate_descriptor
3	X	n/a	HEVC_timing_and_HRD_descriptor()
4	X	n/a	af_extensions_descriptor()
5	X	n/a	HEVC_operation_point_descriptor()
6	X	n/a	HEVC_hierarchy_extension_descriptor()
7	X	n/a	Green_extension_descriptor()
8	X	n/a	MPEG-H_3dAudio_descriptor()
9	X	n/a	MPEG-H_3dAudio_config_descriptor()
0x0A	X	n/a	MPEG-H_3dAudio_scene_descriptor()
0x0B	X	n/a	MPEG-H_3dAudio_text_label_descriptor()
0x0C	X	n/a	MPEG-H_3dAudio_multi-stream_descriptor()
0x0D	X	n/a	MPEG-H_3dAudio_drc_loudness_descriptor()
0x0E	X	n/a	MPEG-H_3dAudio_command_descriptor()
0x0F	X	n/a	Quality_extension_descriptor()
0x10	X	n/a	Virtual_segmentation_descriptor()
0x11	X	n/a	timed_metadata_extension_descriptor()
0x12	X	n/a	HEVC_tile_substream_descriptor()
0x13	X	n/a	HEVC_subregion_descriptor()
0x14	X	n/a	JXS_video_descriptor()
0x15	X	n/a	VVC_timing_and_HRD_descriptor()
0x16	X	n/a	EVC_timing_and_HRD_descriptor()
0x17	X	X	LCEVC_video_descriptor()
0x18	X	X	LCEVC_linkage_descriptor()
0x19	X	X	Media_service_kind_descriptor()
0x1A .. 0xFF	n/a	n/a	Rec. ITU-T H.222.0   ISO/IEC 13818-1 Reserved

**2.6.92 ODUpdate\_descriptor**

The ODUpdate\_descriptor may be used to carry a set of ObjectDescriptors through an ObjectDescriptorUpdate, as a replacement or as a complement to ISO/IEC 14496 object descriptor streams defined in the IOD. If used, the ObjectDescriptorUpdate command shall be processed by the MPEG-4 terminal as defined in 7.2.5.5.2 of ISO/IEC 14496-1. The descriptors carried in the ODUpdate\_descriptor are in the same name scope as the scene description described in the InitialObjectDescriptor carried in the IOD descriptor.

When an ODUpdate\_descriptor is used within a transport stream, the ODUpdate\_descriptor shall be conveyed in the descriptor loop immediately following the program\_info\_length field in the program map table, and shall be included after an IOD descriptor.

When an ODUpdate\_descriptor is used within a program stream, the ODUpdate\_descriptor shall be conveyed in the descriptor loop immediately following the program\_stream\_info\_length field in the program stream map, and shall be included after an IOD descriptor.

If an ODUpdate\_descriptor is included before an IOD descriptor or if IOD descriptor is not present, then the ODUpdate\_descriptor shall be ignored. More than one ODUpdate\_descriptor may be included in a program map table or program stream map.

**2.6.93 Transport\_profile\_descriptor**

The Transport\_profile\_descriptor (see Table 2-111) may be associated in the PMT to signal a profile value of transport stream in the associated program. When present, the descriptor shall only be located in the loop following the program\_info\_length field in the PMT. If the descriptor is not included in the PMT, then the associated transport stream conforms to the complete profile.

Table 2-111 – Transport\_profile\_descriptor syntax

Syntax	No. of bits	Mnemonic
Transport_profile_descriptor{ <b>descriptor_tag</b> <b>descriptor_length</b> <b>transport_profile</b> for (i=0; i<N; i++) { <b>private_data</b> } }	8 8 8 8	<b>uimsbf</b> <b>uimsbf</b> <b>uimsbf</b> <b>bslbf</b>

#### 2.6.94 Semantic definition of fields in the Transport\_profile\_descriptor

**transport\_profile** – This 8-bit profile value signals the use of constraints in the associated transport stream for the program. See Table 2-112.

Table 2-112 – Transport\_profile values

Values	Description
0x00	unspecified
0x01	Complete profile <sup>a</sup>
0x02	Adaptive profile <sup>b</sup>
0x03 .. 0x0E	reserved
0x0F .. 0xFF	user_private <sup>c</sup>
<sup>a</sup> Transport streams using this profile conform to all the normative definitions for transport streams. These include conformant discontinuities, PCR jitter/accuracy, strict T-STD management, PCR interval conformance (less than 100 ms), as well as PTS/DTS interval (0.7 seconds) and compliance. <sup>b</sup> Transport streams using this profile conform to all the normative definitions for transport streams with the following exceptions: <ul style="list-style-type: none"> <li>– The PCR jitter may exceed the specified tolerance as applications that use this profile usually do not include null-PID packets. Clients that process these streams usually do not use the PCR to derive the decoder STC. However, the PCR value can be used in conjunction with the PTS and DTS for conformant STD management of all the media components in the associated program;</li> <li>– the PCR interval occasionally exceeds 100 ms in applications that use this profile due to occasional bit rate variations in certain locations;</li> <li>– conforming continuity counter errors and time base discontinuity may occur more frequently than in complete profile.</li> </ul> <sup>c</sup> User private values of transport_profile that need unique identification can use the MPEG registration_descriptor with a unique format_identifier value that is obtained from the Registration Authority.	

#### 2.6.95 HEVC video descriptor

For an HEVC video stream, the HEVC video descriptor (see Table 2-113) provides basic information for identifying coding parameters, such as profile and level parameters of that HEVC video stream. For an HEVC temporal video sub-bitstream or an HEVC temporal video subset, the HEVC video descriptor provides information such as the associated HEVC highest temporal sub-layer representation contained in the elementary stream to which it applies. This descriptor can also be used to indicate presence of WCG and HDR video components in the associated PID as well as additional parameters to assist decoders with HDR capability to render intended video data on HDR capable display devices. In addition, this can assist non-HDR capable decoders to use the information appropriately.

NOTE 1 – In case that the video characteristics change over time, care should be taken that the descriptor is updated accordingly.

This descriptor, when present, shall only be used for elementary streams with a stream\_type value of 0x24, 0x25 or 0x31. If more than one program element with a stream\_type value of 0x31 is carried in a program, an HEVC\_video\_descriptor may only be used for the first of these program elements. In this case, the information in the HEVC\_video\_descriptor applies to the combination of all HEVC tile substreams with a HEVC tile substream descriptor indicating SubstreamID values in the range of 0 up to TotalSubstreamIDs, as indicated in the HEVC subregion descriptor. When the program element for which the HEVC video descriptor is used is part of an HEVC layered video stream, i.e., the program contains at least one other program element with a stream\_type value in the range of 0x28 .. 0x2B, the semantics of HEVC\_still\_present\_flag, HEVC\_24hr\_picture\_present\_flag and sub\_pic\_hrd\_params\_not\_present\_flag shall apply to the whole HEVC layered video stream, i.e., also to all program elements with a stream\_type value in the range of 0x28 .. 0x2B.

NOTE 2 – For elementary streams with a *stream\_type* value in the range of 0x28 .. 0x2B, the applicable value of *level\_idc* can be ambiguous and depend on the output layer set, i.e., the combination with other elementary streams. This information is signalled by the HEVC operation point descriptor.

Table 2-113 – HEVC video descriptor

Syntax	No. of bits	Mnemonic
HEVC_video_descriptor() {		
<b>descriptor_tag</b>	8	uimsbf
<b>descriptor_length</b>	8	uimsbf
<b>profile_space</b>	2	uimsbf
<b>tier_flag</b>	1	bslbf
<b>profile_idc</b>	5	uimsbf
<b>profile_compatibility_indication</b>	32	bslbf
<b>progressive_source_flag</b>	1	bslbf
<b>interlaced_source_flag</b>	1	bslbf
<b>non_packed_constraint_flag</b>	1	bslbf
<b>frame_only_constraint_flag</b>	1	bslbf
<b>copied_44bits</b>	44	bslbf
<b>level_idc</b>	8	uimsbf
<b>temporal_layer_subset_flag</b>	1	bslbf
<b>HEVC_still_present_flag</b>	1	bslbf
<b>HEVC_24hr_picture_present_flag</b>	1	bslbf
<b>sub_pic_hrd_params_not_present_flag</b>	1	bslbf
<b>reserved</b>	2	bslbf
<b>HDR_WCG_idc</b>	2	bslbf
if ( <i>temporal_layer_subset_flag</i> == '1' ) {		
<b>temporal_id_min</b>	3	uimsbf
<b>reserved</b>	5	bslbf
<b>temporal_id_max</b>	3	uimsbf
<b>reserved</b>	5	bslbf
}		
}		

2.6.96 Semantic definition of fields in HEVC video descriptor

**profile\_space, tier\_flag, profile\_idc, profile\_compatibility\_indication, progressive\_source\_flag, interlaced\_source\_flag, non\_packed\_constraint\_flag, frame\_only\_constraint\_flag, level\_idc** – When the HEVC video descriptor applies to an HEVC video stream or to an HEVC complete temporal representation, these fields shall be coded according to the semantics defined in Rec. ITU-T H.265 | ISO/IEC 23008-2 for *general\_profile\_space, general\_tier\_flag, general\_profile\_idc, general\_profile\_compatibility\_flag[i], general\_progressive\_source\_flag, general\_interlaced\_source\_flag, general\_non\_packed\_constraint\_flag, general\_frame\_only\_constraint\_flag, general\_level\_idc*, respectively, for the corresponding HEVC video stream or HEVC complete temporal representation, and the entire HEVC video stream or HEVC complete temporal representation to which the HEVC video descriptor is associated shall conform to the information signalled by these fields.

When the HEVC video descriptor applies to an HEVC temporal video sub-bitstream or HEVC temporal video subset of which the corresponding HEVC highest temporal sub-layer representation is not an HEVC complete temporal representation, these fields shall be coded according to the semantics defined in Rec. ITU-T H.265 | ISO/IEC 23008-2 for *sub\_layer\_profile\_space, sub\_layer\_tier\_flag, sub\_layer\_profile\_idc, sub\_layer\_profile\_compatibility\_flag[i], sub\_layer\_progressive\_source\_flag, sub\_layer\_interlaced\_source\_flag, sub\_layer\_non\_packed\_constraint\_flag, sub\_layer\_frame\_only\_constraint\_flag, sub\_layer\_level\_idc*, respectively, for the corresponding HEVC highest temporal sub-layer representation, and the entire HEVC highest temporal sub-layer representation to which the HEVC video descriptor is associated shall conform to the information signalled by these fields.

The 32 flags *general\_profile\_compatibility\_flag[i]* or *sub\_layer\_profile\_compatibility\_flag[i]*, with index *i* ranging from 0 to 31, are arranged in the bit string *profile\_compatibility\_indication* with index *i* equal to 0 at the leftmost position and index *i* increasing from left to right in the bit string.

NOTE 1 – In one or more sequences in the HEVC video stream the level may be lower than the level signalled in the HEVC video descriptor, while also a profile may occur that is a subset of the profile signalled in the HEVC video descriptor. However, in the entire HEVC video stream, only subsets of the entire bitstream syntax shall be used that are included in the profile signalled in the HEVC video descriptor, if present. If the sequence parameter sets in an HEVC video stream signal different profiles, and no additional constraints are signalled, then the stream may need examination to determine which profile, if any, the entire stream conforms to. If an HEVC video descriptor is to be associated with an HEVC video stream that does not conform to a single profile,

then the HEVC video stream should be partitioned into two or more sub-streams, so that HEVC video descriptors can signal a single profile for each such sub-stream.

**copied\_44bits** – When the HEVC video descriptor applies to an HEVC video stream or to an HEVC complete temporal representation, this bit field shall be coded according to the semantics of the syntax elements defined in Rec. ITU-T H.265 | ISO/IEC 23008-2 for the 44 bits found in the `profile_tier_level()` syntax element between `general_frame_only_constraint_flag` and `general_level_idc` for the corresponding HEVC video stream or HEVC complete temporal representation, and the entire HEVC video stream or HEVC complete temporal representation to which the HEVC video descriptor is associated shall conform to the information signalled by these fields.

When the HEVC video descriptor applies to an HEVC temporal video sub-bitstream or HEVC temporal video subset of which the corresponding HEVC highest temporal sub-layer representation is not an HEVC complete temporal representation, this bit field shall be coded according to the semantics of the syntax elements defined in Rec. ITU-T H.265 | ISO/IEC 23008-2 for the 44 bits found in the `profile_tier_level()` syntax element between `sub_layer_frame_only_constraint_flag` and `sub_layer_level_idc` for the corresponding HEVC highest temporal sub-layer representation, and the entire HEVC highest temporal sub-layer representation to which the HEVC video descriptor is associated shall conform to the information signalled by these fields.

**temporal\_layer\_subset\_flag** – This 1-bit flag, when set to '1', indicates that the syntax elements describing a subset of temporal layers are included in this descriptor. This field shall be set to 1 for HEVC temporal video subsets and for HEVC temporal video sub-bitstreams. When set to '0', the syntax elements `temporal_id_min` and `temporal_id_max` are not included in this descriptor.

**HEVC\_still\_present\_flag** – This 1-bit field, when set to '1', indicates that the HEVC video stream or the HEVC highest temporal sub-layer representation may include HEVC still pictures. When the `HEVC_still_present_flag` is set to '0', the associated HEVC video stream shall not contain HEVC still pictures.

When the program element to which this descriptor applies is part of an HEVC layered video stream and the `HEVC_still_present_flag` is set to '0', the whole HEVC layered video stream shall not contain HEVC still pictures.

NOTE 2 – According to Rec. ITU-T H.265 | ISO/IEC 23008-2, IDR pictures are always associated with a `TemporalId` value equal to 0. Consequently, if the HEVC video descriptor applies to an HEVC temporal video subset, HEVC still pictures can only be present in the associated HEVC temporal video sub-bitstream.

**HEVC\_24\_hour\_picture\_present\_flag** – This 1-bit flag, when set to '1', indicates that the associated HEVC video stream or the HEVC highest temporal sub-layer representation may contain HEVC 24-hour pictures. For the definition of an HEVC 24-hour picture, see 2.1.49. When the `HEVC_24_hour_picture_present_flag` is set to '0', the associated HEVC video stream shall not contain any HEVC 24-hour pictures.

When the program element to which this descriptor applies is part of an HEVC layered video stream and `HEVC_24_hour_picture_present_flag` is set to '0', the whole HEVC layered video stream shall not contain any HEVC 24-hour pictures.

**sub\_pic\_hrd\_params\_not\_present\_flag** – This 1-bit field, when set to '0', indicates that the VUI in the HEVC video stream shall have the syntax element `sub_pic_hrd_params_present_flag` set to '1'. When the `sub_pic_hrd_params_not_present_flag` is equal to '1', the associated HEVC video stream may not contain `sub_pic_hrd_params_present_flag` in the VUI or the `sub_pic_hrd_params_present_flag` may be set to '0'.

When the program element to which this descriptor applies is part of an HEVC layered video stream and `sub_pic_hrd_params_not_present_flag` is set to '0', the following apply:

- The HEVC timing and HRD descriptor shall be present in the program map table associated with the program.  
NOTE 3 – If `sub_picture_hrd_params_not_present` equals '0', HRD parameters can be expected to be present, though the `hrd_management_valid_flag` is not mandated to be set to '1' in this case.
- The HRD parameter structures that are applicable for all program elements with `stream_type` value of 0x24, 0x25, or in the range of 0x28 .. 0x2B, inclusively, shall be present in the HEVC video stream and the value of `sub_pic_hrd_params_present_flag` in those HRD parameter structures shall be set to '1'.

**HDR\_WCG\_idc** – The value of this syntax element indicates the presence or absence of high dynamic range (HDR) and/or wide color gamut (WCG) video components in the associated PID according to Table 2-114. HDR is defined to be video that has high dynamic range if the video stream EOTF is higher than the Rec. ITU-R BT.1886 reference EOTF. This field also shall not be set to 2 unless `bit_depth_luma_minus8` as defined in Rec. ITU-T H.265 | ISO/IEC 23008-2 in the associated video is greater than or equal to 2. WCG is defined to be video that is coded using colour primaries with a colour gamut not contained within Rec. ITU-R BT.709-6. This field also shall not be set to 1 or 2 unless `bit_depth_chroma_minus8` as defined in Rec. ITU-T H.265 | ISO/IEC 23008-2 in the associated video is greater than or equal to 2.

Table 2-114 – Semantics of HDR\_WCG\_idc

HDR_WCG_idc	Description
0	SDR (i.e., SDR video) is based on the Rec. ITU-R BT.709 OETF using BT.709 color primaries with a corresponding reference EOTF for flat panel displays as specified in Rec. ITU-R BT.1886 (see Note 1)
1	WCG only, i.e., video color gamut in a Rec ITU-R BT.2020 container that exceeds Rec. ITU-R BT.709-6 (see Note 2)
2	Both HDR and WCG are to be indicated in the stream (see Note 3)
3	No indication made regarding HDR/WCG or SDR characteristics of the stream

NOTE 1 – An example where it would be desirable to set HDR\_WCG\_idc to 0 would be when the colour\_description\_present\_flag, as defined in Rec. ITU-T H.265 | ISO/IEC 23008-2, is set to '0', with colour\_primaries and transfer\_characteristics not present in the video stream.

NOTE 2 – An example where it would be desirable to set HDR\_WCG\_idc to 1 would be when colour\_primaries as defined in Rec. ITU-T H.265 | ISO/IEC 23008-2 is equal to 9 to indicate Rec. ITU-R BT.2020.

NOTE 3 – An example where it would be desirable to set HDR\_WCG\_idc to 2 would be when transfer\_characteristics as defined in Rec. ITU-T H.265 | ISO/IEC 23008-2 is equal to 16 to indicate BT.2100 PQ EOTF or equal to 18 to indicate BT.2100 HLG EOTF, and when colour\_primaries as defined in Rec. ITU-T H.265 | ISO/IEC 23008-2 is equal to 9 to indicate Rec. ITU-R BT.2020.

**temporal\_id\_min** – This 3-bit field indicates the minimum value of the *TemporalId*, as defined in Rec. ITU-T H.265 | ISO/IEC 23008-2, of all HEVC access units in the associated elementary stream.

**temporal\_id\_max** – This 3-bit field indicates the maximum value of the *TemporalId*, as defined in Rec. ITU-T H.265 | ISO/IEC 23008-2, of all HEVC access units in the associated elementary stream.

**2.6.97 HEVC timing and HRD descriptor**

For an HEVC video stream, an HEVC temporal video sub-bitstream or an HEVC temporal video subset, the HEVC timing and HRD descriptor (see Table 2-115) provides timing and HRD parameters, as defined in Annex C of Rec. ITU-T H.265 | ISO/IEC 23008-2, for the associated HEVC video stream or the HEVC highest temporal sub-layer representation thereof, respectively.

Table 2-115 – HEVC timing and HRD descriptor

Syntax	No. of bits	Mnemonic
HEVC_timing_and_HRD_descriptor() {		
<b>hrd_management_valid_flag</b>	1	bslbf
<b>target_schedule_idx_not_present_flag</b>	1	bslbf
<b>target_schedule_idx</b>	5	uimsbf
<b>picture_and_timing_info_present_flag</b>	1	bslbf
if (picture_and_timing_info_present_flag == '1') {		
<b>90kHz_flag</b>	1	bslbf
<b>reserved</b>	7	bslbf
if (90kHz_flag == '0') {		
<b>N</b>	32	uimsbf
<b>K</b>	32	uimsbf
}		
<b>num_units_in_tick</b>	32	uimsbf
}		

**2.6.98 Semantic definition of fields in HEVC timing and HRD descriptor**

**hrd\_management\_valid\_flag** – This 1-bit flag is only defined for use in transport streams. When the HEVC timing and HRD descriptor is associated with an HEVC video stream or with an HEVC highest temporal sub-layer representation carried in a transport stream, then the following rules apply.

When the value of hrd\_management\_valid\_flag is equal to '1', Buffering Period SEI and Picture Timing SEI messages, as defined in Annex C of Rec. ITU-T H.265 | ISO/IEC 23008-2, shall be present in the associated HEVC video stream or HEVC highest temporal sub-layer representation. For HEVC layered video streams, each HEVC operation point signalled in the HEVC operation point descriptor shall have applicable Buffering Period SEI and Picture Timing SEI messages. All Buffering Period SEI messages shall carry coded nal\_initial\_cpb\_removal\_delay and nal\_initial\_cpb\_removal\_offset values and may additionally carry nal\_initial\_alt\_removal\_delay and nal\_initial\_alt\_cpb\_removal\_offset values for the

NAL HRD. If the `hrd_management_valid_flag` is set to '1', then the transfer of each byte from  $MB_n$  to  $EB_n$  in the T-STD as defined in 2.17.2 or the transfer from  $MB_{n,k}$  to  $EB_n$  in the T-STD as defined in 2.17.3 or the transfer of each byte from  $MB_{l,k}$  to  $EB_l$  in the T-STD as defined in 2.17.4 shall be according to the delivery schedule for that byte into the CPB in the NAL HRD, as determined from the coded `nal_initial_cpb_removal_delay` and `nal_initial_cpb_removal_offset` or from the coded `nal_initial_alt_cpb_removal_delay` and `nal_initial_alt_cpb_removal_offset` values for `SchedSelIdx` equal to `target_schedule_idx`, as specified in Annex C of Rec. ITU-T H.265 | ISO/IEC 23008-2. When the `hrd_management_valid_flag` is set to '0', the leak method shall be used for the transfer from  $MB_n$  to  $EB_n$  in the T-STD as defined in 2.17.2 or the transfer from  $MB_{n,k}$  to  $EB_n$  in the T-STD as defined in 2.17.3 or the transfer from  $MB_{l,k}$  to  $EB_l$  in the T-STD as defined in 2.17.4.

**target\_schedule\_idx\_not\_present\_flag** – This 1-bit flag when set to '0' indicates that the following 5 bits represent the value `target_schedule_idx` as specified below. When set to '1', the following 5 bits are unspecified. When `hrd_management_valid_flag` is equal to 0, then `target_schedule_idx_not_present_flag` shall be set to '1'.

**target\_schedule\_idx** – When `target_schedule_idx_not_present_flag` is equal to '0', this 5-bit field indicates the index of the delivery schedule which is assigned for `SchedSelIdx`. When the value of `target_schedule_idx_not_present_flag` is equal to '1' and the value of `hrd_management_valid_flag` is equal to '1', the value of `target_schedule_idx` is inferred to be equal to '0'.

**picture\_and\_timing\_info\_present\_flag** – This 1-bit flag when set to '1' indicates that the `90kHz_flag` and parameters for accurate mapping to a 90-kHz system clock are included in this descriptor.

**90kHz\_flag** – This 1-bit flag when set to '1' indicates that the frequency of the HEVC time base is 90 kHz.

**N, K** – For an HEVC video stream or HEVC highest temporal sub-layer representation, the frequency of the HEVC time base is defined by the syntax element `vui_time_scale` in the VUI parameters, as defined in Annex E of Rec. ITU-T H.265 | ISO/IEC 23008-2. The relationship between the HEVC `time_scale` and the `STC` shall be defined by the parameters N and K in this descriptor as follows.

$$time\_scale = (N \times system\_clock\_frequency) / K$$

If the `90kHz_flag` is set to '1', then N equals 1 and K equals 300. If the `90kHz_flag` is set to '0', then the values of N and K are provided by the coded values of the N and K fields.

NOTE – This allows mapping of time expressed in units of `time_scale` to 90 kHz units, as needed for the calculation of PTS and DTS timestamps, for example in decoders for HEVC access units for which no PTS or DTS is encoded in the PES header.

**num\_units\_in\_tick** – This 32-bit field is coded exactly in the same way as the `vui_num_units_in_tick` field in VUI parameters in Annex E of Rec. ITU-T H.265 | ISO/IEC 23008-2. The information provided by this field shall apply to the entire HEVC video stream or HEVC highest temporal sub-layer representation to which the HEVC timing and HRD descriptor is associated.

**2.6.99 AF extensions descriptor**

The AF extensions descriptor (see Table 2-116) is used to signal that adaptation field descriptors could be present in the adaptation header of the component, as defined in 2.4.3.5.

NOTE – There may be AF descriptors in an adaptation field of a TS packet even though this descriptor is not set for the component.

**Table 2-116 – Adaptation field extension descriptor**

Syntax	No. of bits	Mnemonic
<code>af_extensions_descriptor() { }</code>		

**2.6.100 HEVC operation point descriptor**

The HEVC operation point descriptor (see Table 2-117) provides a method to indicate profile and level for one or more HEVC operation points. When present, the HEVC operation point descriptor shall be included in the group of data elements which immediately follow the `program_info_length` field in the `program_map` section.

NOTE – For some applications, the TS may not contain all operation points described in the HEVC operation point descriptor, or the HEVC operation point descriptor may not describe all operation points available in the TS. However, as far as matching elementary streams are found in the TS, the information provided in the descriptor should describe the operation points correctly.

Table 2-117 – HEVC operation point descriptor

Syntax	No. of bits	Mnemonic
HEVC_operation_point_descriptor() {		
<b>reserved</b>	2	bslbf
<b>num_ptl</b>	6	uimsbf
for ( i = 0; i < num_ptl; i++, i++ ) {		
<b>profile_tier_level_info[i]</b>	96	bslbf
}		
<b>operation_points_count</b>	8	uimsbf
for ( i = 0; i < operation_points_count; i++ ) {		
<b>target_ols[i]</b>	8	uimsbf
<b>ES_count[i]</b>	8	uimsbf
for ( j = 0; j < ES_count[i]; j++ ) {		
<b>reserved</b>	1	bslbf
<b>prepend_dependencies[i][j]</b>	1	bslbf
<b>ES_reference[i][j]</b>	6	uimsbf
}		
<b>reserved</b>	2	bslbf
<b>numEsInOp[i]</b>	6	uimsbf
for ( k = 0; k < NumESinOP[i]; k++ ) {		
<b>necessary_layer_flag[i][k]</b>	1	bslbf
<b>output_layer_flag[i][k]</b>	1	bslbf
<b>ptl_ref_idx[i][k]</b>	6	uimsbf
}		
<b>reserved</b>	1	bslbf
<b>avg_bit_rate_info_flag[i]</b>	1	bslbf
<b>max_bit_rate_info_flag[i]</b>	1	bslbf
<b>constant_frame_rate_info_idc[i]</b>	2	uimsbf
<b>applicable_temporal_id[i]</b>	3	uimsbf
if ( constant_frame_rate_info_idc[i] > 0 ) {		
<b>reserved</b>	4	bslbf
<b>frame_rate_indicator[i]</b>	12	uimsbf
}		
if ( avg_bit_rate_info_flag[i] == '1' ) {		
<b>avg_bit_rate[i]</b>	24	uimsbf
}		
if ( max_bit_rate_info_flag[i] == '1' ) {		
<b>max_bit_rate[i]</b>	24	uimsbf
}		
}		
}		

**2.6.101 Semantic definition of fields in HEVC operation point descriptor**

**num\_ptl** – This 6-bit field specifies the number of profile, tier and level structures signalled in this descriptor.

**profile\_tier\_level\_info[i]** – This 96-bit field shall be coded according to the syntax structure of profile\_tier\_level defined in 7.3.3 of Rec. ITU-T H.265 | ISO/IEC 23008-2 with the value of profilePresentFlag set equal to '1' and maxNumSubLayersMinus1 set equal to 6.

If multiple HEVC operation point descriptors are found for the same program, all profile\_tier\_level\_info[x] elements of all HEVC operation point descriptors for this program are aggregated in their order of occurrence into a common array, which is referenced in this specification as profile\_tier\_level\_array[]. If there is only a single HEVC operation point descriptor, profile\_tier\_level\_array[] contains the elements profile\_tier\_level\_info[x] in the order as found in that single descriptor.

**operation\_points\_count** – This 8-bit field indicates the number of HEVC operation points described by the list included in the following group of data elements.

**target\_ols[i]** – An 8-bit field that specifies the index into the list of output layer sets in the VPS, associated with the i-th HEVC operation point defined in this descriptor.

**ES\_count[i]** – This 8-bit field indicates the number of ES\_reference values included in the following group of data elements. The aggregation of elementary streams, according to the ordered list indicated in the following group of data elements, forms an HEVC operation point. The value 0xff is reserved.

Let OperationPointESList[i] be the list of elementary streams that are part of the i-th HEVC operation point.

**prepend\_dependencies[i][j]** – This flag if set to '1' specifies that the elementary stream indicated by ES\_reference[i][j], when not present yet in OperationPointESList[i], shall be added into OperationPointESList[i] and the elementary stream indicated by the syntax element hierarchy\_embedded\_layer\_index in the hierarchy descriptor, or all of the elementary streams indicated by the syntax element hierarchy\_ext\_embedded\_layer\_index in the HEVC hierarchy extension descriptor, with the hierarchy layer index value specified by the following syntax element ES\_reference[i][j], when not present yet in OperationPointESList[i], shall be added into OperationPointLayerList[i] immediately before the elementary stream signalled by the ES\_reference[i][j] in ascending order of the value of their associated hierarchy\_embedded\_layer\_index or hierarchy\_ext\_embedded\_layer\_index. When the value of prepend\_dependencies[i][j] is equal to '0', only the elementary stream indicated by ES\_reference[i][j], when not present yet in OperationPointESList[i], shall be added into OperationPointESList[i]. The elementary stream indicated by ES\_reference[i][m] shall be placed earlier (i.e., with a lower index) into OperationPointESList[i] than the elementary stream indicated with ES\_reference[i][n] when m is less than n. The order of elementary stream in the OperationPointESList[i] shall be in ascending order of their hierarchy\_layer\_index values.

**ES\_reference[i][j]** – This 6-bit field indicates the hierarchy layer index value present in the hierarchy descriptor or HEVC hierarchy extension descriptor which identifies an elementary stream. The value of ES\_reference[i][m] and ES\_reference[i][n] for m not equal to n shall not be the same.

**numEsInOp[i]** – This 6-bit field indicates the number of elementary streams in OperationPointESList[i] after all the ESs that are part of the i-th HEVC operation point have been included into OperationPointESList[i] (i.e., after parsing prepend\_dependencies[i][ES\_count[i] – 1]).

**necessary\_layer\_flag[i][k]** – This flag when set to '1' indicates that the k-th elementary stream in OperationPointESList[i] is a necessary layer, as defined in Annex F of Rec. ITU-T H.265 | ISO/IEC 23008-2, of the i-th operation point. This flag equal to '0' indicates that the k-th elementary stream in OperationPointESList[i] is not a necessary layer, as defined in Annex F of Rec. ITU-T H.265 | ISO/IEC 23008-2, of the i-th operation point.

**output\_layer\_flag[i][k]** – This flag when set to '1' indicates that the k-th elementary stream in OperationPointESList[i] is an output layer. Otherwise, when set to '0', it indicates that the k-th elementary stream in OperationPointESList[i] is not an output layer. When the value of necessary\_layer\_flag[i][k] is equal to '0', the value of output\_layer\_flag[i][k] shall be ignored.

**ptl\_ref\_idx[i][k]** – A 6-bit field that indicates the index x to the profile\_tier\_level\_info[x] element of the profile\_tier\_level\_array which applies to the k-th elementary stream in OperationPointESList[i]. When the value of necessary\_layer\_flag[i][k] is equal to '0', the value of ptl\_ref\_idx[i][k] shall be ignored.

**avg\_bit\_rate\_info\_flag[i]** – This flag indicates whether the syntax element avg\_bit\_rate[i] is present in this descriptor.

**max\_bit\_rate\_info\_flag[i]** – This flag indicates whether the syntax element max\_bit\_rate[i] is present in this descriptor.

**constant\_frame\_rate\_info\_idc[i]** – This 2-bit field, in combination with the syntax element frame\_rate\_indicator as specified below, indicates how the frame rate for the associated operation point j is determined. The value of 0 indicates that the frame rate is not specified for the i-th HEVC operation point and that the syntax element frame\_rate\_indicator is not present in this descriptor for the i-th HEVC operation point.

**applicable\_temporal\_id[i]** – This 3-bit field indicates the highest value of TemporalId of the VCL NAL units in the re-assembled HEVC video stream for operation point i.

**frame\_rate\_indicator[i]** – If constant\_frame\_rate\_info\_idc[i] is equal to 1, this 12-bit field indicates a constant number of ticks, as specified in the HEVC timing and HRD descriptor, for the distance in time between two pictures at the i-th HEVC operation point. If constant\_frame\_rate\_info\_idc[i] equals 2, this 12-bit field indicates the frame rate for the i-th operation point measured in frames per second. If constant\_frame\_rate\_info\_idc[i] equals 3, this 12-bit field indicates the frame rate for the i-th HEVC operation point measured in frames per 1.001 seconds.

**avg\_bit\_rate[i]** – This 24-bit field indicates the average bit rate, in 1000 bits per second, of the HEVC layered video stream corresponding to the i-th HEVC operation point.

**max\_bit\_rate[i]** – This 24-bit field indicates the maximum bit rate, in 1000 bits per second, of the HEVC layered video stream corresponding to the i-th HEVC operation point.

2.6.102 HEVC hierarchy extension descriptor

The HEVC hierarchy extension descriptor provides information to identify the program elements containing components of layered HEVC streams (see Table 2-118). When present, this descriptor shall only be used for elementary streams with the stream\_type value 0x28, 0x29, 0x2A or 0x2B.

Table 2-118 – HEVC hierarchy extension descriptor

Syntax	No. of bits	Mnemonic
HEVC_hierarchy_extension_descriptor() {		
<b>extension_dimension_bits</b>	<b>16</b>	<b>bslbf</b>
<b>hierarchy_layer_index</b>	<b>6</b>	<b>uimsbf</b>
<b>temporal_id</b>	<b>3</b>	<b>uimsbf</b>
<b>nuh_layer_id</b>	<b>6</b>	<b>uimsbf</b>
<b>tref_present_flag</b>	<b>1</b>	<b>bslbf</b>
<b>reserved</b>	<b>2</b>	<b>bslbf</b>
<b>num_embedded_layers</b>	<b>6</b>	<b>uimsbf</b>
<b>reserved</b>	<b>2</b>	<b>bslbf</b>
<b>hierarchy_channel</b>	<b>6</b>	<b>uimsbf</b>
for ( i = 0 ; i < num_embedded_layers ; i++ ) {		
<b>reserved</b>	<b>2</b>	<b>bslbf</b>
<b>hierarchy_ext_embedded_layer_index[i]</b>	<b>6</b>	<b>uimsbf</b>
}		
}		

2.6.103 Semantic definition of fields in HEVC hierarchy extension descriptor

When the HEVC hierarchy extension descriptor is present, it is used to specify the dependency of the associated elementary stream to other elementary streams in the same program.

**extension\_dimension\_bits** – A 16-bit field indicating the possible enhancement of the associated program element from the base layer resulting from the program element of the layer with nuh\_layer\_id equal to '0'.

The allocation of the bits to enhancement dimensions is given in Table 2-119.

Table 2-119 – Semantics of extension dimension bits

Index to bits	Description
0	Multi-view enhancement
1	Spatial scalability, including SNR quality or fidelity enhancement
2	Depth enhancement
3	Temporal enhancement
4	Auxiliary enhancement
5 .. 15	Reserved

The i-th bit equal to '1' indicates that the corresponding enhancement dimension is present. When the elementary stream contains auxiliary pictures as defined in Annex F of Rec. ITU-T H.265 | ISO/IEC 23008-2, the value of the 4th bit of extension\_dimension\_bits shall be set equal to '1', otherwise, it shall be set equal to '0'. When the elementary stream contains auxiliary pictures that are depth pictures, as defined in Annex F of Rec. ITU-T H.265 | ISO/IEC 23008-2, the value of both the 2nd and the 4th bits of extension\_dimension\_bits shall be set equal to '1'.

**hierarchy\_layer\_index** – A 6-bit field that defines a unique index of the associated program elements in a table of coding layer hierarchies. Indices shall be unique within a single program definition. For video sub-bitstreams of HEVC video streams conforming to one or more profiles defined in Annex F of Rec. ITU-T H.265 | ISO/IEC 23008-2, this is the program element index, which is assigned in a way that the bitstream order will be correct if the associated dependency layers of the video sub-bitstreams of the same HEVC access unit are re-assembled in increasing order of hierarchy\_layer\_index.

**temporal\_id** – A 3-bit field that specifies the highest TemporalId of the NAL units in the elementary stream associated with this HEVC hierarchy extension descriptor.

**nuh\_layer\_id** – A 6-bit field that specifies the highest nuh\_layer\_id of the NAL units in the elementary stream associated with this HEVC hierarchy extension descriptor.

**tref\_present\_flag** – A 1-bit flag, which when set to '0' indicates that the TREF field may be present in the PES packet headers in the associated elementary stream. The value of '1' for this flag is reserved.

**num\_embedded\_layers** – A 6-bit field that specifies the number of direct dependent program elements that need to be accessed and be present in decoding order before decoding of the elementary stream associated with this HEVC hierarchy extension descriptor.

**hierarchy\_channel** – A 6-bit field that indicates the intended channel number for the associated program element in an ordered set of transmission channels. The most robust transmission channel is defined by the lowest value of this field with respect to the overall transmission hierarchy definition.

NOTE – A given hierarchy\_channel may at the same time be assigned to several program elements.

**hierarchy\_ext\_embedded\_layer\_index[i]** – A 6-bit field that defines the hierarchy\_layer\_index of the program element that needs to be accessed and be present in decoding order before decoding of the elementary stream associated with this HEVC hierarchy extension descriptor.

#### 2.6.104 Green extension descriptor

The syntax of the green extension descriptor containing static metadata is shown in Table 2-120.

Table 2-120 – Green extension descriptor

Syntax	No. of bits	Mnemonic
Green_extension_descriptor() {		
<b>num_constant_backlight_voltage_time_intervals</b>	2	<b>uimsbf</b>
<b>reserved</b>	6	<b>bslbf</b>
for (i=0; i < num_constant_backlight_voltage_time_intervals; i++) {		
<b>constant_backlight_voltage_time_interval[i]</b>	16	<b>uimsbf</b>
}		
<b>num_max_variations</b>	2	<b>uimsbf</b>
<b>reserved</b>	6	<b>bslbf</b>
for (j=0; j < num_max_variations; j++) {		
<b>max_variation[j]</b>	16	<b>uimsbf</b>
}		
}		

#### 2.6.105 Semantics for green extension descriptor

Semantics for all the syntax elements above are specified in 6.4 of ISO/IEC 23001-11.

#### 2.6.106 MPEG-H 3D audio descriptor

The MPEG-H 3D audio descriptor (see Table 2-121) provides information on basic coding information in the associated ISO/IEC 23008-3 stream. This descriptor shall be present in the associated PMT for MPEG-H 3D audio content with stream\_type equal to 0x2D.

Table 2-121 – MPEG-H 3D audio descriptor

Syntax	No. of bits	Mnemonic
MPEG-H_3dAudio_descriptor() {		
<b>mpegh3daProfileLevelIndication</b>	8	<b>uimsbf</b>
<b>interactivityEnabled</b>	1	<b>bslbf</b>
<b>compatibleProfileSetsPresent</b>	1	<b>bslbf</b>
<b>reserved</b>	8	<b>bslbf</b>
<b>referenceChannelLayout</b>	6	<b>uimsbf</b>
if (compatibleProfileSetsPresent == '0') {		
<b>numCompatibleSets</b>	8	<b>uimsbf</b>
for ( n = 0; n < numCompatibleSets; n++ ) {		
<b>CompatibleSetIndication</b>	8	<b>uimsbf</b>
}		
}		
for (i=0; i<N; i++) {		
<b>reserved</b>	8	<b>bslbf</b>
}		
}		

2.6.107 Semantics for MPEG-H 3D audio descriptor

**mpegh3daProfileLevelIndication** – The audio profile and level of the associated ISO/IEC 23008-3 audio stream, encoded as specified for the mpegh3daProfileLevelIndication field in 5.3.2 in ISO/IEC 23008-3.

**referenceChannelLayout** – Reference channel configuration value as defined as "ChannelConfiguration" in ISO/IEC 23001-8 ("Codec Independent Code Points").

**interactivityEnabled** – If set to '1', this flag indicates that the 3D audio stream contains elements with associated metadata which enables user interactivity. If this flag is set to '0', no user interactivity of any kind is available. This flag may be used to determine the need for initializing the user interactivity interface in the Systems decoder.

**compatibleProfileSetsPresent** – A 1-bit flag, which when set to '0' indicates the presence of compatible profile sets.

**numCompatibleSets** – This field signals the number of compatible profile sets present in the current descriptor. The value of this field shall be equal to or higher than 1.

**CompatibleSetIndication** – See CompatibleSetIndication field in the CompatibleProfileLevelSet() config extension in ISO/IEC 23008-3.

2.6.108 MPEG-H 3D audio config descriptor

The MPEG-H 3D audio config descriptor (see Table 2-122) provides information on the complete configuration data of one ISO/IEC 23008-3 stream.

Table 2-122 – MPEG-H 3D audio config descriptor

Syntax	No. of bits	Mnemonic
MPEG-H_3dAudio_config_descriptor() {		
mpegh3daConfig()		
}		

2.6.109 Semantics for MPEG-H 3D audio config descriptor

**mpegh3daConfig()** – The mpegh3daConfig() of the associated ISO/IEC 23008-3 audio stream, as specified in 5.2.2.1 in ISO/IEC 23008-3.

2.6.110 MPEG-H 3D audio scene descriptor

The MPEG-H 3D audio scene descriptor (see Table 2-123) provides information on user selectable and/or modifiable audio objects in an ISO/IEC 23008-3 stream.

Table 2-123 – MPEG-H 3D audio scene descriptor

Syntax	No. of bits	Mnemonic
MPEG-H_3dAudio_scene_descriptor() {		
<b>groupDefinitionPresent</b>	1	bslbf
<b>switchGroupDefinitionPresent</b>	1	bslbf
<b>groupPresetDefinitionPresent</b>	1	bslbf
reserved	5	bslbf
<b>3dAudioSceneInfoID</b>	8	bslbf
if (groupDefinitionPresent) {		
reserved	1	bslbf
<b>numGroups</b>	7	uimsbf
for ( i=0; i < numGroups; i++) {		
reserved	1	bslbf
<b>mae_groupID</b>	7	uimsbf
reserved	3	bslbf
<b>mae_allowOnOff</b>	1	bslbf
<b>mae_defaultOnOff</b>	1	bslbf
<b>mae_allowPositionInteractivity</b>	1	bslbf
<b>mae_allowGainInteractivity</b>	1	bslbf
<b>mae_hasContentLanguage</b>	1	bslbf
reserved	4	bslbf
<b>mae_contentKind</b>	4	uimsbf
if ( mae_allowPositionInteractivity ) {		
reserved	1	bslbf
<b>mae_interactivityMinAzOffset</b>	7	uimsbf
reserved	1	bslbf
<b>mae_interactivityMaxAzOffset</b>	7	uimsbf
reserved	3	bslbf
<b>mae_interactivityMinEIOffset</b>	5	uimsbf
reserved	3	bslbf
<b>mae_interactivityMaxEIOffset</b>	5	uimsbf
<b>mae_interactivityMinDistOffset</b>	4	uimsbf
<b>mae_interactivityMaxDistOffset</b>	4	uimsbf
}		
if ( mae_allowGainInteractivity ) {		
reserved	2	bslbf
<b>mae_interactivityMinGain</b>	6	uimsbf
reserved	3	bslbf
<b>mae_interactivityMaxGain</b>	5	uimsbf
}		
if ( mae_hasContentLanguage ) {		
<b>mae_contentLanguage</b>	24	uimsbf
}		
}		
}		
if (switchGroupDefinitionPresent) {		
reserved	3	bslbf
<b>numSwitchGroups</b>	5	uimsbf

Table 2-123 – MPEG-H 3D audio scene descriptor

Syntax	No. of bits	Mnemonic
for ( i=0; i < numSwitchGroups; i++) {		
<b>reserved</b>	1	bslbf
<b>mae_switchGroupID</b>	5	uimsbf
<b>mae_switchGroupAllowOnOff</b>	1	bslbf
<b>mae_switchGroupDefaultOnOff</b>	1	bslbf
<b>reserved</b>	3	bslbf
<b>mae_bsSwitchGroupNumMembers</b>	5	uimsbf
for ( i = 0; i < mae_bsSwitchGroupNumMembers + 1; i++) {		
<b>reserved</b>	1	bslbf
<b>mae_switchGroupMemberID</b>	7	uimsbf
}		
<b>reserved</b>	1	bslbf
<b>mae_switchGroupDefaultGroupID</b>	7	uimsbf
}		
}		
if (presetGroupDefinitionPresent) {		
<b>reserved</b>	3	bslbf
<b>mae_numGroupPresets</b>	5	uimsbf
for ( i = 0; i < mae_numGroupPresets; i++) {		
<b>reserved</b>	3	bslbf
<b>mae_groupPresetID</b>	5	uimsbf
<b>reserved</b>	3	bslbf
<b>mae_groupPresetKind</b>	5	uimsbf
<b>reserved</b>	4	bslbf
<b>mae_numGroupPresetConditions</b>	4	uimsbf
for ( j = 0; j < mae_numGroupPresetConditions+1; j++) {		
<b>mae_groupPresetGroupID</b>	7	uimsbf
<b>mae_groupPresetConditionOnOff</b>	1	bslbf
if (mae_groupPresetConditionOnOff) {		
<b>reserved</b>	4	bslbf
<b>mae_groupPresetDisableGainInteractivity</b>	1	bslbf
<b>mae_groupPresetGainFlag</b>	1	bslbf
<b>mae_groupPresetDisablePositionInteractivity</b>	1	bslbf
<b>mae_groupPresetPositionFlag</b>	1	bslbf
if ( mae_groupPresetGainFlag ) {		
<b>mae_groupPresetGain</b>	8	uimsbf
}		
} if( mae_groupPresetPositionFlag ){		
<b>mae_groupPresetAzOffset</b>	8	uimsbf
<b>reserved</b>	2	bslbf
<b>mae_groupPresetEIOffset</b>	6	uimsbf
<b>reserved</b>	4	bslbf
<b>mae_groupPresetDistFactor</b>	4	uimsbf
}		
}		
}		
}		
}		

Table 2-123 – MPEG-H 3D audio scene descriptor

Syntax	No. of bits	Mnemonic
<pre> for (i=0; i&lt;N; i++) {     reserved } </pre>	8	bslbf

### 2.6.111 Semantic definition of fields in MPEG-H 3D audio scene descriptor

**groupDefinitionPresent** – A one-bit flag signalling the presence of interactivity information of one group in this descriptor.

**groupContentDataPresent** – A one-bit flag signalling the presence of content information of one group in this descriptor.

**switchGroupDefinitionPresent** – A one-bit flag signalling the presence of switch group information in this descriptor.

**presetGroupDefinitionPresent** – A one-bit flag signalling the presence of preset group information in this descriptor.

**3dAudioSceneInfoID** – See 'mae\_audioSceneInfoID' in 15.3 of ISO/IEC 23008-3.

**numGroups** – This field signals the number of groups in the audio scene description. This field can take values between 1 and 127, and shall be less or equal to the value of mae\_numGroups present in the associated ISO/IEC 23008-3 stream.

**mae\_groupID** – See 15.3 of ISO/IEC 23008-3.

**mae\_allowOnOff** – See 15.3 of ISO/IEC 23008-3.

**mae\_defaultOnOff** – See 15.3 of ISO/IEC 23008-3.

**mae\_allowPositionInteractivity** – See 15.3 of ISO/IEC 23008-3.

**mae\_allowGainInteractivity** – See 15.3 of ISO/IEC 23008-3.

**mae\_hasContentLanguage** – See 15.3 of ISO/IEC 23008-3.

**mae\_contentKind** – See 15.3 of ISO/IEC 23008-3.

**mae\_interactivityMinAzOffset** – See 15.3 of ISO/IEC 23008-3.

**mae\_interactivityMaxAzOffset** – See 15.3 of ISO/IEC 23008-3.

**mae\_interactivityMinElOffset** – See 15.3 of ISO/IEC 23008-3.

**mae\_interactivityMaxElOffset** – See 15.3 of ISO/IEC 23008-3.

**mae\_interactivityMinDistOffset** – See 15.3 of ISO/IEC 23008-3.

**mae\_interactivityMaxDistOffset** – See 15.3 of ISO/IEC 23008-3.

**mae\_interactivityMinGain** – See 15.3 of ISO/IEC 23008-3.

**mae\_interactivityMaxGain** – See 15.3 of ISO/IEC 23008-3.

**mae\_contentLanguage** – See 15.3 of ISO/IEC 23008-3.

**numSwitchGroups** – This field signals the number of switch groups minus one in the overall scene. This field can take values between 0 and 31, resulting in a maximum number of 32 switch groups. It shall be less or equal to the value of mae\_numSwitchGroups present in the associated ISO/IEC 23008-3 stream.

**mae\_switchGroupID** – See ISO/IEC 23008-3.

**mae\_switchGroupAllowOnOff** – See 15.3 of ISO/IEC 23008-3.

**mae\_switchGroupDefaultOnOff** – See 15.3 of ISO/IEC 23008-3; if mae\_switchGroupAllowOnOff is '0', then mae\_switchGroupDefaultOnOff shall be set to '0'.

**mae\_bsSwitchGroupNumMembers** – See 15.3 of ISO/IEC 23008-3.

**mae\_switchGroupMemberID** – See 15.3 of ISO/IEC 23008-3.

- mae\_switchGroupDefaultGroupID** – See 15.3 of ISO/IEC 23008-3.
- mae\_numGroupPresets** – See 15.3 of ISO/IEC 23008-3.
- mae\_groupPresetID** – See 15.3 of ISO/IEC 23008-3.
- mae\_groupPresetKind** – See 15.3 of ISO/IEC 23008-3.
- mae\_groupPresetNumConditions** – See 15.3 of ISO/IEC 23008-3.
- mae\_groupPresetGroupID** – See 15.3 of ISO/IEC 23008-3.
- mae\_groupPresetConditionOnOff** – See 15.3 of ISO/IEC 23008-3.
- mae\_groupPresetDisableGainInteractivity** – See 15.3 of ISO/IEC 23008-3.
- mae\_groupPresetGainFlag** – See 15.3 of ISO/IEC 23008-3.
- mae\_groupPresetDisablePositionInteractivity** – See 15.3 of ISO/IEC 23008-3.
- mae\_groupPresetPositionFlag** – See 15.3 of ISO/IEC 23008-3.
- mae\_groupPresetGain** – See 15.3 of ISO/IEC 23008-3.
- mae\_groupPresetAzOffset** – See 15.3 of ISO/IEC 23008-3.
- mae\_groupPresetEIOffset** – See 15.3 of ISO/IEC 23008-3.
- mae\_groupPresetDistFactor** – See 15.3 of ISO/IEC 23008-3.

Data fields provided both in this descriptor and as in-band information in the ISO/IEC 23008-3 stream shall be set to the same value.

**2.6.112 MPEG-H 3D audio text label descriptor**

The MPEG-H 3D audio scene descriptor provides text labels for the audio objects and presets in an ISO/IEC 23008-3 stream. See Table 2-124.

**Table 2-124 – MPEG-H 3D audio text label descriptor**

Syntax	No. of bits	Mnemonic
MPEG-H_3dAudio_text_label_descriptor() {		
<b>3dAudioSceneInfoID</b>	8	<b>uimsbf</b>
<b>reserved</b>	4	<b>bslbf</b>
<b>numDescLanguages</b>	4	<b>uimsbf</b>
for (i=0; i< numDescLanguage; i++) {		
<b>descriptionLanguage</b>	24	<b>uimsbf</b>
<b>reserved</b>	1	<b>bslbf</b>
<b>numGroupDescriptions</b>	7	<b>uimsbf</b>
for ( n = 0; n < numGroupDescriptions; n++ ) {		
<b>reserved</b>	1	<b>bslbf</b>
<b>mae_descriptionGroupID;</b>	7	<b>uimsbf</b>
<b>groupDescriptionDataLength</b>	8	<b>uimsbf</b>
for ( c = 0; c < groupDescriptionDataLength; c++ ) {		
<b>groupDescriptionData</b>	8	<b>uimsbf</b>
}		
}		
<b>reserved</b>	3	<b>bslbf</b>
<b>numSwitchGroupDescriptions</b>	5	<b>uimsbf</b>
for ( n = 0; n < numSwitchGroupDescriptions; n++ ) {		
<b>reserved</b>	3	<b>bslbf</b>
<b>mae_descriptionSwitchGroupID;</b>	5	<b>uimsbf</b>
<b>switchGroupDescriptionDataLength</b>	8	<b>uimsbf</b>
}		
}		

Table 2-124 – MPEG-H 3D audio text label descriptor

Syntax	No. of bits	Mnemonic
<pre> for ( c = 0; c &lt; switchGroupDescriptionDataLength; c++ ) {     switchGroupDescriptionData } </pre>	8	uimsbf
<pre> reserved </pre>	3	bslbf
<pre> numGroupPresetsDescriptions </pre>	5	uimsbf
<pre> for ( n = 0; n &lt; numGroupPresetsDescriptions; n++ ) {     reserved </pre>	3	bslbf
<pre>     mae_descriptionGroupPresetID </pre>	5	uimsbf
<pre>     groupPresetDescriptionDataLength </pre>	8	uimsbf
<pre>     for ( c = 0; c &lt; groupPresetDescriptionLength; c++ ) {         groupPresetDescriptionData     } </pre>	8	uimsbf
<pre> } </pre>		
<pre> for ( i=0; i&lt;N; i++ ) {     reserved } </pre>	8	bslbf
<pre> } </pre>		

### 2.6.113 Semantic definition of fields in MPEG-H 3D audio text label descriptor

**3dAudioSceneInfoID** – See 'mae\_audioSceneInfoID' in 15.3 ISO/IEC 23008-3.

**numDescLanguages** – The number of available languages for description text.

**descriptionLanguage** – Identifies the language or languages used by the description text of a metadata element group. It contains a 3-character code as specified by ISO 639-2. Both ISO 639-2/B and ISO 639-2/T may be used. Each character is coded into 8 bits according to ISO/IEC 8859-1 and inserted in order into the 24-bit field.

**numGroupDescriptions** – The number of available descriptions for groups.

**mae\_descriptionGroupID** – See 15.3 of ISO/IEC 23008-3.

**groupDescriptionDataLength** – The length, specified in bytes, of the following group description.

**groupDescriptionData** – This field contains a description of a metadata element group, i.e., a string describing the content by a high-level description. The format shall follow UTF-8 according to ISO/IEC 10646.

**numSwitchGroupDescriptions** – The number of available descriptions for switch groups.

**mae\_descriptionSwitchGroupID** – See 15.3 of ISO/IEC 23008-3.

**switchGroupDescriptionDataLength** – The length, specified in bytes, of the following switch group description.

**switchGroupDescriptionData** – This field contains a description of a switch group, i.e., a string describing the content by a high-level description. The format shall follow UTF-8 according to ISO/IEC 10646.

**numGroupPresetsDescriptions** – The number of available descriptions for group presets.

**mae\_descriptionGroupPresetID** – See 15.3 of ISO/IEC 23008-3.

**groupPresetDescriptionDataLength** – The length, specified in bytes, of the following group preset description.

**groupPresetDescriptionData** – This field contains a description of a metadata element group, i.e., a string describing the content by a high-level description. The format shall follow UTF-8 according to ISO/IEC 10646.

Data fields provided both in this descriptor and as in-band information in the IS/IEC 23008-3 stream shall be set to the same value.

2.6.114 MPEG-H 3D audio multi-stream descriptor

The MPEG-H 3D audio multi-stream descriptor (see Table 2-125) provides information on the location of each mae\_groupID in case of transmission over multiple streams.

In combination with this descriptor, an MPEG-H 3D audio scene descriptor explaining the actual representation of the overall audio scene is required to be present in the descriptor loop of the main stream.

Table 2-125 – MPEG-H 3D audio multi-stream descriptor

Syntax	No. of bits	Mnemonic
MPEG-H_3dAudio_multi-stream_descriptor() {		
<b>thisIsMainStream</b>	1	bslbf
<b>thisStreamID</b>	7	uimsbf
if ( thisIsMainStream ) {		
<b>reserved</b>	1	slbf
<b>numAuxiliaryStreams</b>	7	uimsbf
<b>reserved</b>	1	bslbf
<b>mae_numGroups</b>	7	uimsbf
for (i=0; i<mae_numGroups; i++) {		
<b>mae_groupID</b>	7	uimsbf
<b>isInMainStream</b>	1	bslbf
if ( thisIsMainStream == '0' ) {		
<b>isInTS</b>	1	bslbf
<b>auxiliaryStreamID</b>	7	uimsbf
}		
}		
}		
for (i=0; i<N; i++) {		
<b>reserved</b>	8	bslbf
}		
}		

2.6.115 Semantic definition of fields in MPEG-H 3D audio multi-stream descriptor

**thisIsMainStream** – If this flag is '1', the stream is a main stream, otherwise it is an auxiliary stream.

**thisStreamID** – This integer provides a unique ID of all available ISO/IEC 23008-3 Audio streams with MHAS transport syntax, both main and auxiliary streams (stream\_type 0x2D and 0x2E).

**numAuxiliaryStreams** – This integer provides information on how many auxiliary stream are available.

**mae\_numGroups** – This field signals the number of groups in the overall audio scene (complete number of groups in the main stream plus all possible additional streams). This field can take values between 1 and 127. It shall be set to the same value as the corresponding field in the associated ISO/IEC 23008-3 stream.

**mae\_groupID** – This integer provides information on the mae\_groupID (as described in ISO/IEC 23008-3, section 15) the loop instance refers to.

**isInMainStream** – If this flag is set to '1', the audio data related to the group (as indicated through mae\_groupID) is present in the main stream, otherwise the encoded data is transmitted in an auxiliary stream.

**isInTS** – If this flag is set to '1', the audio data related to the group (as indicated through mae\_groupID) is present in the same transport stream. If this flag is set to 0, the data must be retrieved from an external source.

**auxiliaryStreamID** – In case of transmission of encoded audio data as identified by groupID in an auxiliary stream, this integer identifies the used auxiliary stream.

The location of the 'external source' may be signalled using the TEMI location descriptor and/or the TEMI BaseURL\_descriptor as defined in clause U.3.

When the TEMI descriptor(s) are conveyed in a TEMI\_AU as a separate elementary stream on a separated PID, an MPEG-H\_3dAudio\_extStreamID\_descriptor() shall be present in the associated descriptor loop of the TEMI elementary stream which provides an ID in the field "auxiliaryStreamID" that is matching the "auxiliaryStreamID" provided in the MPEG-H\_3dAudio\_multi-stream\_descriptor() of the main stream.

### 2.6.116 MPEG-H 3D audio DRC and Loudness descriptor

The MPEG-H 3D audio dynamic range control (DRC) and Loudness descriptor (see Table 2-126) provides information on DRC and Loudness information contained in an ISO/IEC 23008-3 stream.

Table 2-126 – MPEG-H 3D audio DRC and Loudness descriptor()

Syntax	No. of bits	Mnemonic
MPEG-H_3dAudio_drc_loudness_descriptor () {		
<b>reserved</b>	7	bslbf
<b>mpegh3daDrcAndLoudnessInfoPresent</b>	1	bslbf
if (mpegh3daDrcAndLoudnessInfoPresent) {		
<b>reserved</b>	2	bslbf
<b>drcInstructionsUniDrcCount</b>	6	uimsbf
<b>reserved</b>	2	bslbf
<b>loudnessInfoCount</b>	6	uimsbf
<b>reserved</b>	3	bslbf
<b>downmixIdCount</b>	5	uimsbf
for (i=0; i<drcInstructionsUniDrcCount; i++) {		
<b>reserved</b>	6	bslbf
<b>drcInstructionsType</b>	2	uimsbf
if (drcInstructionsType == 2) {		
<b>reserved</b>	1	bslbf
<b>mae_groupID</b>	7	uimsbf
} else if (drcInstructionsType == 3) {		
<b>reserved</b>	3	bslbf
<b>mae_groupPresetID</b>	5	uimsbf
}		
<b>reserved</b>	2	bslbf
<b>drcSetId</b>	6	uimsbf
<b>reserved</b>	1	bslbf
<b>downmixId</b>	7	uimsbf
<b>reserved</b>	3	bslbf
<b>additionalDownmixIdCount</b>	3	uimsbf
<b>limiterPeakTargetPresent</b>	1	bslbf
<b>drcSetTargetLoudnessPresent</b>	1	bslbf
for (j=0; j<additionalDownmixIdCount; j++) {		
<b>reserved</b>	1	bslbf
<b>additionalDownmixId</b>	7	uimsbf
}		
<b>drcSetEffect</b>	16	uimsbf
if ( limiterPeakTargetPresent ) {		
<b>bsLimiterPeakTarget</b>	8	uimsbf
}		
if ( drcSetTargetLoudnessPresent ) {		
<b>reserved</b>	1	bslbf
<b>bsDrcSetTargetLoudnessValueUpper</b>	6	uimsbf
<b>drcSetTargetLoudnessValueLowerPresent</b>	1	bslbf
if(drcSetTargetLoudnessValueLowerPresent) {		
<b>reserved</b>	2	bslbf
<b>bsDrcSetTargetLoudnessValueLower</b>	6	uimsbf
}		
}		
}		

Table 2-126 – MPEG-H 3D audio DRC and Loudness descriptor()

Syntax	No. of bits	Mnemonic
<pre> } reserved dependsOnDrcSet if (dependsOnDrcSet == 0) {     noIndependentUse } else {     reserved } } for (i=0; i&lt;loudnessInfoCount; i++) {     reserved     loudnessInfoType     if (loudnessInfoType == 1    loudnessInfoType == 2) {         reserved         mae_groupID     } else if (loudnessInfoType == 3) {         reserved         mae_groupPresetID     }     loudnessInfo_size     loudnessInfo() } for (i=0; i&lt;downmixIdCount; i++) {     reserved     downmixId     downmixType     CICPSpeakerLayoutIdx } } for (i=0; i&lt;N; i++) {     reserved } } </pre>	<p>1</p> <p>6</p> <p>1</p> <p>1</p> <p>6</p> <p>2</p> <p>1</p> <p>7</p> <p>3</p> <p>5</p> <p>8</p> <p>1</p> <p>7</p> <p>2</p> <p>6</p> <p>8</p>	<p>bslbf</p> <p>uimsbf</p> <p>bslbf</p> <p>bslbf</p> <p>bslbf</p> <p>uimsbf</p> <p>uimsbf</p> <p>uimsbf</p> <p>uimsbf</p> <p>uimsbf</p> <p>bslbf</p> <p>uimsbf</p> <p>uimsbf</p> <p>uimsbf</p> <p>bslbf</p>

2.6.117 Semantic definition of fields in MPEG-H 3D audio DRC and Loudness descriptor

**mpegh3daDrcAndLoudnessInfoPresent** – A one-bit flag signalling the presence of dynamic range control and loudness information in this descriptor.

**drcInstructionsUniDrcCount** – This field signals the number of DRC sets in the stream. This field can take values between 0 and 63, resulting in a maximum number of 63 DRC sets.

**loudnessInfoCount** – This field signals the number of loudness info blocks in the stream. This field can take values between 0 and 63, resulting in a maximum number of 63 loudness info blocks.

**downmixIdCount** – This field signals the number of downmixId definitions in the stream. This field can take values between 0 and 31, resulting in a maximum number of 31 downmixId definitions.

**drcInstructionsType** – See ISO/IEC 23008-3.

**mae\_groupID** – See ISO/IEC 23008-3.

**mae\_groupPresetID** – See ISO/IEC 23008-3.

**drcSetId** – See ISO/IEC 23003-4.

**downmixId** – See ISO/IEC 23003-4 and ISO/IEC 23008-3.

**additionalDownmixIdCount** – See ISO/IEC 23003-4.

**limiterPeakTargetPresent** – See ISO/IEC 23003-4.

**drcSetTargetLoudnessPresent** – See ISO/IEC 23003-4.

- additionalDownmixId** – See ISO/IEC 23003-4.
- drcSetEffect** – See ISO/IEC 23003-4.
- bsLimiterPeakTarget** – See ISO/IEC 23003-4.
- bsDrcSetTargetLoudnessValueUpper** – See ISO/IEC 23003-4.
- drcSetTargetLoudnessValueLowerPresent** – See ISO/IEC 23003-4.
- bsDrcSetTargetLoudnessValueLower** – See ISO/IEC 23003-4.
- dependsOnDrcSet** – See ISO/IEC 23003-4.
- noIndependentUse** – See ISO/IEC 23003-4.
- loudnessInfoType** – See ISO/IEC 23008-3.
- loudnessInfo\_size** – The number of bytes of the immediately following loudnessInfo().
- loudnessInfo()** – One loudnessInfo() structure as defined in ISO/IEC 23003-4.
- downmixType** – See ISO/IEC 23008-3.
- CICPspeakerLayoutIdx** – See ISO/IEC 23008-3.

Data fields provided both in this descriptor and as in-band information in the IS/IEC 23008-3 stream shall be set to the same value.

**2.6.118 MPEG-H 3D audio command descriptor**

The MPEG-H 3D audio command descriptor (see Table 2-127) encapsulates an MHAS packet of the type PACTYP\_USERINTERACTION that contains an interaction command or type PACTYP\_AUDIOSCENEINFO that contains the audio scene information. Both types are supported by a MPEG-H 3D audio decoder.

By inserting the MHAS packet contained in this descriptor into the MHAS elementary stream, a receiver can send this command to the MPEG-H 3D audio decoder. As the descriptor contains a complete MHAS packet including MHAS header, nothing else needs to be added when multiplexing these bytes, consecutively, on an MHAS packet boundary in the MHAS stream.

**Table 2-127 – MPEG-H 3D audio command descriptor**

Syntax	No. of bits	Mnemonic
<pre>MPEG-H_3dAudio_command_descriptor() {     for (i = 0; i &lt; N; i++) {         data     } }</pre>	<b>8</b>	<b>bslbf</b>

**data** – Data bytes shall be contiguous bytes of data from a complete MHAS packet (including the MHAS header) of the type PACTYP\_USERINTERACTION.

**2.6.119 Quality extension descriptor**

The quality extension descriptor shall be sent once per event or program and hence is signalled using a descriptor in the program map table. This descriptor shall appear in the elementary stream loop of the PID for which quality information is provided.

Dynamic quality metadata is stored in access units and is associated with one or more video frames. These access units are encapsulated in MPEG sections identified by stream\_type value of 0x2F.

The quality extension descriptor describes metrics that are present in each Quality Access Unit, and the constant field size that is used for the values. The quality metrics are defined in 4.3 of ISO/IEC 23001-10.

The syntax of quality extension descriptor containing static metadata is shown in Table 2-128.

Table 2-128 – Quality extension descriptor

Syntax	No. of bits	Mnemonic
Quality_extension_descriptor() { <b>field_size_bytes</b> <b>metric_count</b> for (i=0; i < metric_count; i++) { <b>metric_code[i]</b> } }	8 8 32	<b>uimsbf</b> <b>uimsbf</b> <b>uimsbf</b>

**field\_size\_bytes** – The constant size in byte of the value for a metric in each Quality Access Unit.

**metric\_count** – The number of metrics for quality values in each Quality Access Unit

**metric\_code** – The code name of the metrics in the Quality Access Unit.

Semantics for all the syntax elements above are specified in 4.2 of ISO/IEC 23001-10. The quality metrics to be signalled can also be found in 4.3 of ISO/IEC 23001-10 and include:

- PSNR = Peak Signal to Noise Ratio
- SSIM = Structural Similarity Index
- MS-SSIM = Multi-Scale Structural Similarity Index
- VQM = Video Quality Metric
- PEVQ = Perceptual Evaluation of Video Quality
- MOS = Mean Opinion Score
- FSIG = Frame significance

#### 2.6.120 Virtual segmentation descriptor

The virtual segmentation descriptor (see Table 2-129) appears in the elementary stream descriptor loop in the PMT and is used to indicate that the current elementary stream is virtually segmented using boundary descriptors (see U.3.11). This segmentation may come in a set of partitions – e.g., one partition demarcates the stream into 10-s virtual segments, while another creates 2-s virtual segments. If the boundary descriptor carried in transport stream packets appears in the elemental stream declared by the PMT stream description carrying the virtual segmentation descriptor, it is an explicit indication of segment boundary point, otherwise a reference PID shall be defined in the virtual segmentation descriptor; that reference PID indicates that segment boundary points are indicated in another elemental stream, for which the boundary descriptor shall be present in the PMT. The virtual segmentation for elementary streams for which no virtual segmentation descriptor is present in the PMT is undefined.

Table 2-129 – Virtual segmentation descriptor

Syntax	No. of bits	Mnemonic
Virtual_segmentation_descriptor(){ if (descriptor_length > 1) { <b>num_partitions</b> <b>timescale_flag</b> <b>reserved</b> if ( timescale_flag == 1 ) { <b>ticks_per_second</b> <b>maximum_duration_length_minus_1 (MDL)</b> <b>reserved</b> } } for ( i = 0; i < num_partitions; i++ ) { <b>explicit_boundary_flag</b> <b>partition_id</b> <b>reserved</b> <b>SAP_type_max</b> if (explicit_boundary_flag == 0) { <b>reserved</b> <b>boundary_PID</b> <b>reserved</b> } else { <b>maximum_duration</b> } } } }	3 1 4 21 2 1  1 3 4 3 5 13 3  MDL*8 + 5	<b>uimsbf</b> <b>bslbf</b> <b>bslbf</b> <b>uimsbf</b> <b>uimsbf</b> <b>bslbf</b>  <b>bslbf</b> <b>uimsbf</b> <b>bslbf</b> <b>uimsbf</b> <b>bslbf</b> <b>uimsbf</b> <b>bslbf</b>  <b>uimsbf</b>

### 2.6.121 Semantic definition of fields in virtual segmentation descriptor

**timescale\_flag:** If set to '1', timescale information is present. If set to '0', ticks\_per\_second is inferred to be 1, and MDL is inferred to be 0 (i.e., maximum\_duration\_length\_minus\_1=−1). The value of '0' allows maximum segment duration of up to 31 seconds, expressed in integer seconds.

**ticks\_per\_second:** Precision, in ticks per second, of the maximum\_duration field, e.g., 0.1 second precision is 10 ticks/s, 0.01 second precision with 100 ticks/s, etc.

**maximum\_duration\_length\_minus\_1:** Length, in bytes (minus one), of the maximum\_duration field variable byte length. This provides additional bytes in addition to the 5 bits pre-allocated to the maximum\_duration field.

**num\_partitions:** Number of partitions described in the virtual segmentation descriptor.

**explicit\_boundary\_flag:** If set to '0', this elementary stream is a dependent stream, and boundary data for it is provided on a reference partition on a different PID, specified by boundary\_PID; otherwise, the current PID carries boundary descriptors.

**partition\_id:** ID of the partition described in the boundary descriptor.

**boundary\_PID:** PID carrying boundary\_descriptor() that is used by this partition of this elementary stream.

**SAP\_type\_max:** Maximum possible value of SAP in this partition. If SAP\_type\_max value is 0, any SAP value may appear in the stream.

**maximum\_duration:** Maximum virtual segment duration for a segment on partition partition\_id, expressed in units of ticks\_per\_second. For consecutive virtual segments S(i) and S(i+1) on the above partition, if PTS(i) stands for the earliest PTS in segment S(i), and PTS(i+1) stands for the earliest PTS in segment S(i+1) this duration equals (PTS(i+1) – PTS(i))\*ticks\_per\_second/90000. If set to 0, virtual segment duration is unlimited.

### 2.6.122 HEVC tile substream descriptor

For each ES containing an HEVC tile substream (i.e., a tile or fixed set of subsequent tiles), an HEVC tile substream descriptor (see Table 2-130) assigns a SubstreamID to that HEVC tile substream. It optionally contains additional SubstreamIDs needed to form a subregion or an index to a pattern that indicates these additional SubstreamIDs by an array of offsets found in the HEVC subregion descriptor. Type and length of the descriptor are provided by header bytes that are not shown in the following syntax table.

Table 2-130 – HEVC tile substream descriptor

Syntax	No. of bits	Mnemonic
<pre> HEVC_tile_substream_descriptor() {   ReferenceFlag   SubstreamID   if ( descriptor_length &gt; 1 ) {     if ( ReferenceFlag == '1' ) {       PreambleFlag       PatternReference     }     else {       for ( i=0; i&lt;N1; i++ ) {         Flag[i]         AdditionalSubstreamID[i]       }     }   } } </pre>	<p>1</p> <p>7</p> <p>1</p> <p>7</p> <p>1</p> <p>7</p>	<p>bslbf</p> <p>uimsbf</p> <p>bslbf</p> <p>uimsbf</p> <p>bslbf</p> <p>uimsbf</p>
<p>Note: The value N1 is implied by the descriptor size. It equals the value of descriptor_length minus 1.</p>		

The HEVC tile substream descriptor can be used in three different ways, each signalling the SubstreamID:

- a) If its size is only one byte (preceding header bytes excluded), ReferenceFlag is reserved. It implicitly signals a value of 0 for the PatternReference (referring to SubstreamOffset[k][0][i] in the HEVC subregion descriptor as specified below)
- b) If ReferenceFlag is set to '1', it specifies the index of the pattern to be used to calculate additional SubstreamIDs (other than index 0)
- c) If ReferenceFlag is set to '0', it specifies the additional SubstreamIDs directly

**2.6.123 Semantic definition of the fields in the HEVC tile substream descriptor**

**ReferenceFlag** – When this bit is set to '1', this descriptor indicates the index  $j > 0$  of the pattern signalled by the HEVC subregion descriptor to be used to calculate additional SubstreamIDs. If the value of the field descriptor\_length specifying the size of this descriptor excluding preceding header bytes is 1, the value of ReferenceFlag is reserved.

**SubstreamID** – This 7-bit field assigns a number in the range of 1 to TotalSubstreamIDs (as found) to the HEVC tile substream, which is unique among all ESS with stream type equal to 0x31 or 0x24 (the latter in case that multiple substreams are carried in a single ES) that belong to the same program. This value is used to identify each HEVC tile substream. The value 0 is used for substreams that contain information applicable to multiple HEVC tile substreams.

**PreambleFlag** – When this bit is set to '1' and each HEVC tile substream is carried in its own ES (signalled by the SubstreamMarkingFlag in the HEVC subregion descriptor set to '1'), an access unit carried in the ES signalled by the value of PreambleSubstreamID in the HEVC subregion descriptor is prepended before an access unit carried in this ES as specified in 2.17.5.2. In case SubstreamMarkingFlag in the HEVC subregion descriptor set to '0', the semantics of this flag is reserved.

**PatternReference** – This 7-bit field assigns a number in the range of 1 to PatternCount (as found in the HEVC subregion descriptor) to the HEVC tile substream. This number is used as an index  $j$  to the array SubstreamOffset[k][j][i] when the reassembly process is executed.

**Flag[i]** – When Flag[0] is set to '1' and each HEVC tile substream is carried in its own ES (signalled by the SubstreamMarkingFlag in the HEVC subregion descriptor set to '1'), an additional ES signalled by the value of PreambleSubstreamID in the HEVC subregion descriptor is prepended before this ES. In other cases, the semantics of Flag[0] is reserved. Flag[i] for values of  $i > 0$  is reserved.

NOTE – If ReferenceFlag is set to '0', Flag[0] has the same semantics as PreambleFlag for the case that ReferenceFlag is set to '1'.

**AdditionalSubstreamID** – This array of 7 bit fields indicates additional SubstreamIDs that belong to the subregion when the reassembly process according to 2.17.5.2 or 2.17.5.3 is executed.

### 2.6.124 HEVC tile substream af\_descriptor

When multiple HEVC tile substreams are carried in the same ES, HEVC tile substream selection shall be based on signalization using HEVC tile substream af\_descriptors. The syntax of this descriptor is specified in Table U.15.

### 2.6.125 HEVC subregion descriptor

One HEVC subregion descriptor is associated to the whole program. The HEVC subregion descriptor signals patterns of SubstreamIDs that belong to a subregion. Its syntax is given in Table 2-131, the semantics are specified in 2.6.126. It can signal different layouts, which e.g. consist of different numbers of HEVC tile substreams, and indicate the level value of the profile as specified in ISO/IEC 23008-2 that applies for each pattern. It also indicates how HEVC tile substreams are identified.

NOTE – As the subregion comprises less pixels than the whole panorama, the level value for the subregion is less than or equal to the level value that applies for the whole panorama.

If multiple HEVC tile substreams, e.g. the whole panorama, are contained in a single ES, the motion-constrained tile sets extraction information set SEI message shall be present at all random access points.

Table 2-131 — HEVC subregion descriptor

Syntax	No. of bits	Mnemonic
HEVC_subregion_descriptor() {		
<b>SubstreamMarkingFlag</b>	1	bslbf
<b>SubstreamIDsPerLine</b>	7	uimsbf
<b>TotalSubstreamIDs</b>	8	uimsbf
<b>LevelFullPanorama</b>	8	uimsbf
for ( i=0; i<N1; i++ ) {		
if ( SubstreamMarkingFlag == 1 ) {		
<b>reserved</b>	1	bslbf
<b>PreambleSubstreamID[i]</b>	7	uimsbf
}		
<b>SubstreamCountMinus1[i]</b>	8	uimsbf
<b>Level[i]</b>	8	uimsbf
<b>PictureSizeHor[i]</b>	16	uimsbf
<b>PictureSizeVert[i]</b>	16	uimsbf
<b>reserved</b>	1	bslbf
<b>PatternCount[i]</b>	7	uimsbf
for ( j=0; j<PatternCount[i]; j++ ) {		
for ( k=0; k<SubstreamCountMinus1[i]; k++ ) {		
<b>SubstreamOffset[k][j][i]</b>	8	tcimsbf
}		
}		
}		
}		

NOTE: The value N1 is implied by the descriptor size. It equals the number of different subregion layouts, indexed by i, that can be selected from the whole panorama.

### 2.6.126 Semantic definition of the fields in the HEVC subregion descriptor

**SubstreamMarkingFlag** – This 1 bit flag, when set to '1' indicates that each HEVC tile substream is carried in a separate ES. When set to '0', multiple HEVC tile substreams are carried in a common ES and HEVC tile substreams are identified by HEVC tile substream af\_descriptors.

**SubstreamIDsPerLine** – This 7-bit value indicates the number of HEVC tile substreams that are coded representations of tiles that are arranged horizontally and span the width of the whole panorama.

**TotalSubstreamIDs** – This 8-bit value indicates the total number of HEVC tile substreams that represent tiles for the whole panorama. It does not include any additional HEVC tile substreams that provide slice headers and parameter sets.

**LevelFullPanorama** – This 8-bit value indicates the level value of the profile as specified in ISO/IEC 23008-2 that applies for the whole panorama.

**PreambleSubstreamID[i]** – The value of this 7-bit field indicates the SubstreamID of the ES to be prepended to the ES to which this descriptor applies when the reassembly process is executed. The value can be either 0 or in the range of TotalSubstreamIDs +1 to 127. This field is only available when each HEVC tile substream is carried in its own ES.

**SubstreamCountMinus1[i]** – The value of this 8-bit field in the range of 0 to (TotalSubstreamIDs – 1) indicates

- in case that SubstreamMarkingFlag is set to '1': the number of HEVC tile substreams to be appended to the ES to which this descriptor applies when the reassembly process according to 2.17.5.2 is executed;
- in case that SubstreamMarkingFlag is set to '0': the number of HEVC tile substreams to be added to the list of SubstreamIDs that belong to the subregion when the reassembly process according to 2.17.5.3 is executed;

**Level[i]** – This 8-bit field indicates the value of the profile as specified in ISO/IEC 23008-2 that applies that applies to the subregion layout indexed by i.

**PictureSizeHor[i]** – This 16-bit field indicates the horizontal subregion dimension, measured in pixels.

**PictureSizeVert[i]** – This 16-bit field indicates the vertical subregion dimension, measured in pixels.

**PatternCount[i]** – This 7-bit field indicates the number of different subregion layouts.

**SubstreamOffset[k][j][i]** – This array of 8 bit fields indicates the offset that has to be added

- in case that SubstreamMarkingFlag is set to '1': to the SubstreamID of the ES to which this descriptor applies. The resulting value indicates the SubstreamID of the ES to be appended when the reassembly process is executed;
- in case that SubstreamMarkingFlag is set to '0': to the SubstreamID<sub>x</sub> that relates to the upper left HEVC tile substream of the region to be displayed. The resulting value indicates the SubstreamID to be added to the list of SubstreamIDs that belong to the subregion.

NOTE – Examples are shown in Annex V.

#### 2.6.127 JPEG XS video descriptor

For JPEG XS video elementary streams conforming to ISO/IEC 21122-1 and to one or more profiles defined in ISO/IEC 21122-2, the JPEG XS video descriptor (see Table 2-132) provides information that may be present in each JPEG XS access unit as well as for the JPEG XS video sequence. In addition, it provides information to signal JPEG XS still pictures. This descriptor shall be included for each JPEG XS video elementary stream component in the PMT with stream\_type equal to 0x32.

Table 2-132 – JPEG XS video descriptor

Syntax	No. of bits	Mnemonic
JXS_video_descriptor() {		
<b>descriptor_version</b>	8	uimsbf
<b>horizontal_size</b>	16	uimsbf
<b>vertical_size</b>	16	uimsbf
<b>brat</b>	32	uimsbf
<b>frat</b>	32	bslbf
<b>schar</b>	16	bslbf
<b>Ppih</b>	16	bslbf
<b>Plev</b>	16	bslbf
<b>max_buffer_size</b>	32	uimsbf
<b>buffer_model_type</b>	8	uimsbf
<b>colour primaries</b>	8	uimsbf
<b>transfer characteristics</b>	8	uimsbf
<b>matrix coefficients</b>	8	uimsbf
<b>video_full_range_flag</b>	1	bslbf
<b>reserved</b>	7	bslbf
<b>still_mode</b>	1	bslbf
<b>mdm_flag</b>	1	bslbf
<b>zero_bits</b>	6	bslbf
if (mdm_flag == '1') {		
<b>X_c0, Y_c0, X_c1, Y_c1, X_c2, Y_c2</b>	16x6	uimsbf
<b>X_wp</b>	16	uimsbf
<b>Y_wp</b>	16	uimsbf
<b>L_max</b>	32	uimsbf
<b>L_min</b>	32	uimsbf
<b>MaxCLL</b>	16	uimsbf
<b>MaxFALL</b>	16	uimsbf
}		
for (i=0; i<N; i++) {		
<b>private_data_byte</b>	8	bslbf
}		
}		

### 2.6.128 Semantics of fields in JPEG XS video descriptor

**descriptor\_version** – This 8-bit field specifies the version of the JPEG XS video descriptor in case additional capabilities are added in the future. Value of this field shall be '0000 0000' and all other values are reserved for future use.

**horizontal\_size** – This field shall be coded the same as  $W_f$  parameter found in the JPEG XS codestream picture header, as defined in ISO/IEC 21122-1.

**vertical\_size** – This field shall be coded the same as  $H_f$  parameter found in the JPEG XS codestream picture header, as defined in ISO/IEC 21122-1.

**brat** – This parameter specifies the maximum bitrate of the elementary stream in Mbit per second. A detailed definition can be found in ISO/IEC 21122-3.

**frat** – This parameter specifies the frame rate of the elementary stream and also contains a flag indicating if the stream is interlaced or progressive. A detailed definition can be found in ISO/IEC 21122-3.

**schar** – This parameter specifies the image sample characteristics and the sampling structure. A detailed definition can be found in ISO/IEC 21122-3.

**Ppih** – This field specifies the Profile of the elementary stream. It shall be coded the same as the Ppih parameter defined in ISO/IEC 21122-1 using the values defined in ISO/IEC 21122-2.

**Plev** – This field specifies the level and sublevel of the elementary stream. It shall be coded the same as the Plev parameter defined in ISO/IEC 21122-1 using the values defined in ISO/IEC 21122-2.

**max\_buffer\_size** – This 32-bit field specifies the size of the elementary stream buffer (EB in Figure W.2) required to ensure decoding without overflow nor underflow. This value, expressed in Mbytes, shall not exceed  $(\text{max\_rate}/160)$ ,

where `max_rate` corresponds to the maximum encoded rate allowed by the combination of the selected level and sublevel, as defined in ISO/IEC 21122-2, expressed in Mbits/s. When level or sublevel is unrestricted, `max_buffer_size` shall not exceed (`brat/160`).

**buffer\_model\_type** – This 8-bit field specifies the smoothing buffer model type to which the carried video stream is conforming to. Currently, only value 2 is allowed, other values are reserved for future ISO/IEC use.

NOTE – Streams generated with buffer model type 1 are also compliant with type 2 and can therefore be signalled with this field set to '2'.

**colour\_primaries, transfer\_characteristics, matrix\_coefficients, video\_full\_range\_flag** – These four fields (three 1-byte integers and one 1-bit flag) shall be coded according to the semantics with the same name defined in ISO/IEC 23091-2.

**still\_mode** – This 1-bit field, when set to '1', indicates that the JPEG XS video stream may include JPEG XS still pictures, as described in W.2. When set to '0', then the associated JPEG XS video stream shall not contain JPEG XS still pictures.

**mdm\_flag** – When set to '1', this 1-bit field indicates that the JPEG XS video descriptor contains the characteristics of the Mastering Display Metadata, as described in ISO/IEC 21122-3 (see below corresponding fields). When set to '0', then the JPEG-XS video descriptor shall not contain the characteristics of the Mastering Display Metadata.

**zero\_bits** – These 6 bits shall be all set to '0' and are reserved for future use.

The following fields `X_c0`, `Y_c0`, `X_c1`, `Y_c1`, `X_c2`, `Y_c2`, `X_wp`, `Y_wp`, `L_max` and `L_min` correspond to the fields defined in SMPTE ST2086:2014 "Mastering Display Color Volume Metadata Supporting High Luminance and Wide Color Gamut Images". The fields `MaxFALL` and `MaxCLL` correspond to the fields defined in ANSI/CTA 861-G:2016 "A DTV Profile for Uncompressed High Speed Digital Interfaces". If these 12 fields have unknown values at the time of generating the stream, they shall not be included in the descriptor and the `mdm_flag` shall be set to '0'.

**X\_c0, Y\_c0, X\_c1, Y\_c1, X\_c2, Y\_c2** – These 16-bit fields are included only if the `mdm_flag` is set to '1'. They specify the normalized x and y chromaticity coordinates of the colour primary components of the mastering display in increments of 0.00002, according to the CIE 1931 definition of x and y as specified in ISO 11664-1 (see also ISO 11664-3 and CIE 15). For describing mastering displays that use red, green, and blue colour primaries, it is suggested that index value `c0` should correspond to the green primary, `c1` should correspond to the blue primary, and `c2` should correspond to the red colour primary. The values of these 6 fields shall be in the range of 0 to 50 000, inclusive.

**X\_wp and Y\_wp** – These 16-bit fields are included only if the `mdm_flag` is set to '1'. They specify the normalized x and y chromaticity coordinates of the white point of the mastering display in normalized increments of 0.00002, according to the CIE 1931 definition of x and y as specified in ISO 11664-1 (see also ISO 11664-3 and CIE 15). The values of `X_wp` and `Y_wp` shall be in the range of 0 to 50 000.

**L\_max and L\_min** – These 32-bit fields are included only if the `mdm_flag` is set to '1'. They specify the nominal maximum and minimum display luminance, respectively, of the mastering display. The minimum luminance of the mastering display is computed by  $L_{min} \times 0.0001 \text{ cd/m}^2$ , the maximum luminance by  $L_{max} \times 0.0001 \text{ cd/m}^2$ . `L_min` shall be less than `L_max`. At minimum luminance, the mastering display is considered to have the same nominal chromaticity as the white point.

**MaxCLL** – This 16-bit field is included only if the `mdm_flag` is set to '1'. It specifies the Maximum Content Light Level and corresponds to the brightest pixel in the entire stream, in units of 1 cd/m<sup>2</sup>, where 0x0001 represents 1 cd/m<sup>2</sup> and 0xFFFF represents 65535 cd/m<sup>2</sup>. It shall be calculated according to Annex P Calculation of MaxCLL and MaxFALL section P.1 in ANSI/CTA 861-G:2016 A DTV Profile for Uncompressed High Speed Digital Interfaces.

**MaxFALL** – This 16-bit field is included only if the `mdm_flag` is set to '1'. It specifies the Maximum Frame Average Light Level and corresponds to the highest frame average brightness per frame in the entire stream, in units of 1 cd/m<sup>2</sup>, where 0x0001 represents 1 cd/m<sup>2</sup> and 0xFFFF represents 65535 cd/m<sup>2</sup>. It shall be calculated according to Annex P Calculation of MaxCLL and MaxFALL section P.2 in ANSI/CTA 861-G:2016 "A DTV Profile for Uncompressed High Speed Digital Interfaces".

If for some reason the `MaxCLL` and/or `MaxFALL` values are unknown, the value 0x0000 shall be used.

### 2.6.129 VVC video descriptor

For a VVC video stream, the VVC video descriptor (see Table 2-133) provides basic information for identifying coding parameters, such as profile and level parameters, of that VVC video stream. For a VVC temporal video sub-bitstream or a VVC temporal video subset, the VVC video descriptor provides information such as the associated VVC highest temporal sublayer representation contained in the elementary stream to which it applies.

Table 2-133 – VVC video descriptor

Syntax	No. of bits	Mnemonic
VVC_video_descriptor() {		
<b>descriptor_tag</b>	8	uimsbf
<b>descriptor_length</b>	8	uimsbf
<b>profile_idc</b>	7	uimsbf
<b>tier_flag</b>	1	bslbf
<b>num_sub_profiles</b>	8	uimsbf
for ( i=0; i<num_sub_profiles; i++) {		
<b>sub_profile_idc[ i ]</b>	32	uimsbf
}		
<b>progressive_source_flag</b>	1	bslbf
<b>interlaced_source_flag</b>	1	bslbf
<b>non_packed_constraint_flag</b>	1	bslbf
<b>frame_only_constraint_flag</b>	1	bslbf
<b>reserved_zero_4bits</b>	4	bslbf
<b>level_idc</b>	8	uimsbf
<b>temporal_layer_subset_flag</b>	1	bslbf
<b>VVC_still_present_flag</b>	1	bslbf
<b>VVC_24hr_picture_present_flag</b>	1	bslbf
<b>reserved</b>	5	bslbf
<b>HDR_WCG_idc</b>	2	uimsbf
<b>reserved</b>	2	bslbf
<b>video_properties_tag</b>	4	uimsbf
if ( temporal_layer_subset_flag == '1' ) {		
<b>reserved</b>	5	bslbf
<b>temporal_id_min</b>	3	uimsbf
<b>reserved</b>	5	bslbf
<b>temporal_id_max</b>	3	uimsbf
}		
}		

### 2.6.130 Semantic definition of fields in VVC video descriptor

**profile\_idc, tier\_flag, num\_sub\_profiles, sub\_profile\_idc[ i ]** – These fields shall be coded according to the semantics defined in Rec. ITU-T H.266 | ISO/IEC 23090-3 for general\_profile\_idc, general\_tier\_flag, ptl\_num\_sub\_profiles, general\_sub\_profile\_idc[i], respectively, for the corresponding VVC video stream or VVC complete temporal representation. When the corresponding VVC video stream or VVC complete temporal representation contains a DCI, the values of these fields shall be coded exactly the same as the corresponding fields in the DCI.

**progressive\_source\_flag, interlaced\_source\_flag, non\_packed\_constraint\_flag** – These fields shall be coded according to the semantics defined in Rec. ITU-T H.274 | ISO/IEC 23002-7 for vui\_progressive\_source\_flag, vui\_interlaced\_source\_flag, vui\_non\_packed\_constraint\_flag, respectively, for the corresponding VVC video stream or VVC complete temporal representation.

NOTE 1 – Potentially, the corresponding VVC video stream or VVC complete temporal representation contains an SPS with a vui\_payload() syntax structure that indicates the values of these fields. The semantics defined in Rec. ITU-T H.274 | ISO/IEC 23002-7 allows to indicate that the source scan type of the pictures should be interpreted as unknown or unspecified or specified by external means or that the presence of frame packing arrangement SEI messages is not constraint (unknown or unspecified).

**frame\_only\_constraint\_flag** – This field shall be coded according to the semantics defined in Rec. ITU-T H.266 | ISO/IEC 23090-3 for ptl\_frame\_only\_constraint\_flag for the corresponding VVC video stream or VVC complete temporal representation. When the corresponding VVC video stream or VVC complete temporal representation contains a DCI, the values of this field shall be coded the same as the corresponding field in the DCI.

**reserved\_zero\_4bits** – This field shall be set to '0000'.

**level\_idc** – When the VVC video descriptor applies to a VVC video stream or to a VVC complete temporal representation, this field shall be coded according to the semantics defined in Rec. ITU-T H.266 | ISO/IEC 23090-3 for general\_level\_idc, for the corresponding VVC video stream or VVC complete temporal representation. When the VVC video descriptor applies to a VVC temporal video sub-bitstream or VVC temporal video subset of which the corresponding VVC highest temporal sublayer representation is not a VVC complete temporal representation, this field shall be coded according to

semantics defined in Rec. ITU-T H.266 | ISO/IEC 23090-3 for `sublayer_level_idc`, for the corresponding VVC highest temporal sublayer representation. When the corresponding VVC video stream or VVC complete temporal representation contains a DCI, the values of this field shall be coded exactly the same as the corresponding fields in the DCI.

When the VVC video descriptor applies to a VVC video stream or to a VVC complete temporal representation, the entire VVC video stream or VVC complete temporal representation to which the VVC video descriptor is associated shall conform to the information signaled by these fields. When the VVC video descriptor applies to a VVC temporal video sub-bitstream or VVC temporal video subset of which the corresponding VVC highest temporal sublayer representation is not a VVC complete temporal representation, the entire VVC highest temporal sublayer representation to which the VVC video descriptor is associated shall conform to the information signalled by these fields.

NOTE 2 – In one or more sequences in the VVC video stream the level may be lower than the level signalled in the VVC video descriptor, while also a profile may occur that is a subset of the profile signalled in the VVC video descriptor. However, in the entire VVC video stream, only subsets of the entire bitstream syntax shall be used that are included in the profile signalled in the VVC video descriptor, if present. When the VVC video stream contains a DCI NAL unit, the profile-tier-level indication signals the profile and level information to which all sequences in the VVC video stream conforms. When not, if the sequence parameter sets in a VVC video stream signal different profiles, and no additional constraints are signalled, then the stream may need examination to determine which profile, if any, the entire stream conforms to.

**temporal\_layer\_subset\_flag** – This 1-bit flag, when set to '1', indicates that the syntax elements describing a subset of temporal layers are included in this descriptor. This field shall be set to 1 for VVC temporal video subsets and for VVC temporal video sub-bitstreams. When set to '0', the syntax elements `temporal_id_min` and `temporal_id_max` are not included in this descriptor.

**VVC\_still\_present\_flag** – This 1-bit field, when set to '1', indicates that the VVC video stream or the VVC highest temporal sublayer representation may include VVC still pictures. When set to '0', then the associated VVC video stream shall not contain VVC still pictures.

NOTE 3 – According to Rec. ITU-T H.266 | ISO/IEC 23090-3, IDR pictures are always associated to a `TemporalId` value equal to 0. Consequently, if the VVC video descriptor applies to a VVC temporal video subset, VVC still pictures can only be present in the associated VVC temporal video sub-bitstream.

**VVC\_24\_hour\_picture\_present\_flag** – This 1-bit flag, when set to '1', indicates that the associated VVC video stream or the VVC highest temporal sublayer representation may contain VVC 24-hour pictures. For the definition of a VVC 24-hour picture, see 2.1.153. If this flag is set to '0', the associated VVC video stream shall not contain any VVC 24-hour picture.

**HDR\_WCG\_idc** – This 2-bit field indicates the presence or absence of high dynamic range (HDR) and/or wide colour gamut (WCG) video components in the associated PID according to Table 2-134. This field shall not be set to 2 unless `sps_bit_depth_minus8` as defined in Rec. ITU-T H.266 | ISO/IEC 23090-3 in the associated video is greater than or equal to 2.

Table 2-134 – Semantics of `HDR_WCG_idc`

HDR_WCG_idc	Description
0	SDR (i.e., SDR video) is based on the Rec. ITU-R BT.709 OETF using BT.709 color primaries with a corresponding reference EOTF for flat panel displays as specified in BT.1886 (see Note 1)
1	WCG only, i.e., video color gamut in a Rec. ITU-R BT.2020 container that exceeds Rec. ITU-R BT.709-6 (see Note 2)
2	Both HDR and WCG are to be indicated in the stream (see Note 3)
3	No indication is made regarding HDR/WCG or SDR characteristics of the stream

NOTE 1 – An example where it would be desirable to set `HDR_WCG_idc` to 0 would be when the `colour_description_present_flag`, as defined in Rec. ITU-T H.274 | ISO/IEC 23002-7, is set to '0', with `colour_primaries` and `transfer_characteristics` not present in the video stream.

NOTE 2 – An example where it would be desirable to set `HDR_WCG_idc` to 1 would be when `colour_primaries` as defined in Rec. ITU-T H.274 | ISO/IEC 23002-7 (which refers to the `ColourPrimaries` parameter in Rec. ITU-T H.273 | ISO/IEC 23091-2) is equal to 9 to indicate Rec. ITU-R BT.2020.

NOTE 3 – An example where it would be desirable to set `HDR_WCG_idc` to 2 would be when `transfer_characteristics` as defined in Rec. ITU-T H.274 | ISO/IEC 23002-7 (which refers to the `TransferCharacteristics` parameter in Rec. ITU-T H.273 | ISO/IEC 23091-2) is equal to 16 to indicate BT.2100 PQ EOTF or equal to 18 to indicate BT.2100 HLG EOTF, and when `colour_primaries` as defined in Rec. ITU-T H.274 | ISO/IEC 23002-7 is equal to 9 to indicate Rec. ITU-R BT.2020.

**video\_properties\_tag** – This 4-bit field is used to indicate specific video property CICIP combinations for SDR, WCG, or HDR/WCG streams depending on the value of HDR\_WCG\_idc. The CICIP values are defined in Rec. ITU-T H.273 | ISO/IEC 23091-2. When HDR\_WCG\_idc is equal to 0, Table 2-135 applies. When HDR\_WCG\_idc is equal to 1, Table 2-136 applies. When HDR\_WCG\_idc is equal to 2, Table 2-137 applies. When HDR\_WCG\_idc is equal to 3, Table 2-138 applies.

NOTE 4 – The video\_properties\_tag descriptor can indicate widely used combinations that are documented by. ITU-T H.Sup 19 | ISO/IEC TR 23091-4. The system identifiers found in that Supplement | Technical Report are mentioned in Tables 2-135 to 2-138 for convenience.

**Table 2-135 – SDR widely used video property combinations**

<b>video_properties_tag</b>	<b>CICIP Values – System Identifier [ColourPrimaries, TransferCharacteristics, MatrixCoefficients, VideoFullRangeFlag]</b>
0	Video property CICIP combination not specified or unknown
1	[1,1,1,0]- BT709_YCC
2	[1,1,0,0]- BT709_RGB
3	[6,6,6,0]- BT601_525
4	[5,6,5,0]- BT601_625
5	[1,1,0,1]- FR709_RGB
6-15	Reserved

**Table 2-136 – WCG widely used video property combinations**

<b>video_properties_tag</b>	<b>CICIP Values – System Identifier [ColourPrimaries, TransferCharacteristics, MatrixCoefficients, VideoFullRangeFlag]</b>
0	Video property CICIP combination not specified or unknown
1	[9,14,9,0]- BT2020_YCC_NCL
2	[9,14,0,0]- BT2020_RGB
3	[9,14,0,1]- FR2020_RGB
4	[12,1,6,1]- FRP3D65_YCC
5-15	Reserved

**Table 2-137 – HDR/WCG widely used video property combinations**

<b>video_properties_tag</b>	<b>CICIP Values - System Identifier [ColourPrimaries, TransferCharacteristics, MatrixCoefficients, VideoFullRangeFlag]</b>
0	Video property CICIP combination not specified or unknown
1	[9,16,9,0]- BT2100_PQ_YCC
2	[9,18,9,0]- BT2100_HLG_YCC
3	[9,16,14,0]- BT2100_PQ_ICTCP
4	[9,16,0,0]- BT2100_PQ_RGB
5	[9,18,0,0]- BT2100_HLG_RGB
6-15	Reserved

Table 2-138 – No Indication

video_properties_tag	CICP Values – System Identifier [ColourPrimaries, TransferCharacteristics, MatrixCoefficients, VideoFullRangeFlag]
0	Video property CICP combination not specified or unknown
1-15	Reserved or private

**temporal\_id\_min** – This 3-bit field indicates the minimum value of the TemporalId, as defined in Rec. ITU-T H.266 | ISO/IEC 23090-3, of all VVC access units in the associated elementary stream.

**temporal\_id\_max** – This 3-bit field indicates the maximum value of the TemporalId, as defined in Rec. ITU-T H.266 | ISO/IEC 23090-3, of all VVC access units in the associated elementary stream.

NOTE 5 – These values indicate maximum and minimum values, but they do not guarantee that all temporal layers are present at all times, because the number of temporal layers may change eg. when splicing occurs. However, if the temporal level goes beyond the range given by min and max values, a new descriptor with appropriate values needs to be inserted.

**2.6.131 VVC timing and HRD descriptor**

For a VVC video stream, a VVC temporal video sub-bitstream or a VVC temporal video subset, the VVC timing and HRD descriptor (see Table 2-139) provides timing and HRD parameters, as defined in Annex C of Rec. ITU-T H.266 | ISO/IEC 23090-3, for the associated VVC video stream or the VVC highest temporal sublayer representation thereof, respectively.

Table 2-139 – VVC timing and HRD descriptor

Syntax	No. of bits	Mnemonic
VVC_timing_and_HRD_descriptor() {		
<b>hrd_management_valid_flag</b>	1	bslbf
<b>reserved</b>	6	bslbf
<b>picture_and_timing_info_present_flag</b>	1	bslbf
if (picture_and_timing_info_present_flag == '1') {		
<b>90kHz_flag</b>	1	bslbf
<b>reserved</b>	7	bslbf
if (90kHz_flag == '0') {		
N	32	uimsbf
K	32	uimsbf
}		
<b>num_units_in_tick</b>	32	uimsbf
}		
}		

**2.6.132 Semantic definition of fields in VVC timing and HRD descriptor**

**hrd\_management\_valid\_flag** – This 1-bit flag is only defined for use in transport streams. When the VVC timing and HRD descriptor is associated to a VVC video stream or to a VVC highest temporal sublayer representation carried in a transport stream, then the following applies.

If the hrd\_management\_valid\_flag is set to '1', then Buffering Period SEI and Picture Timing SEI messages, as defined in Annex C of Rec. ITU-T H.266 | ISO/IEC 23090-3, shall be present in the associated VVC video stream or VVC highest temporal sublayer representation. These Buffering Period SEI messages shall carry coded nal\_initial\_cpb\_removal\_delay and nal\_initial\_cpb\_removal\_delay\_offset values and may additionally carry nal\_initial\_alt\_removal\_delay and nal\_initial\_alt\_cpb\_removal\_delay\_offset values for the NAL HRD. If the hrd\_management\_valid\_flag is set to '1', then the transfer of each byte from MB<sub>n</sub> to EB<sub>n</sub> in the T-STD as defined in 2.23.2 or the transfer from MB<sub>n,k</sub> to EB<sub>n</sub> in the T-STD as defined in 2.23.3 shall be according to the delivery schedule for that byte into the CPB in the NAL HRD, as determined from the coded nal\_initial\_cpb\_removal\_delay and nal\_initial\_cpb\_removal\_delay\_offset or from the coded nal\_initial\_alt\_cpb\_removal\_delay and nal\_initial\_alt\_cpb\_removal\_delay\_offset values for SchedSelIdx equal to cpb\_cnt\_minus1 as specified in Annex C of Rec. ITU-T H.266 | ISO/IEC 23090-3. When the hrd\_management\_valid\_flag

is set to '0', the leak method shall be used for the transfer from  $MB_n$  to  $EB_n$  in the T-STD as defined in 2.23.2 or the transfer from  $MB_{n,k}$  to  $EB_n$  in the T-STD as defined in 2.23.3.

**picture\_and\_timing\_info\_present\_flag** – This 1-bit flag when set to '1' indicates that the 90kHz\_flag and parameters for accurate mapping to 90-kHz system clock are included in this descriptor.

**90kHz\_flag** – This 1-bit flag when set to '1' indicates that the frequency of the VVC time base is 90 kHz.

**N, K** – For a VVC video stream or VVC highest temporal sublayer representation, the frequency of the VVC time base is defined by the syntax element *time\_scale* in the SPS or VPS, as defined in 7.3.5 of Rec. ITU-T H.266 | ISO/IEC 23090-3. The relationship between the VVC *time\_scale* and the STC shall be defined by the parameters N and K in this descriptor as follows.

$$time\_scale = (N \times system\_clock\_frequency) / K$$

If the 90kHz\_flag is set to '1', then N equals 1 and K equals 300. If the 90kHz\_flag is set to '0', then the values of N and K are provided by the coded values of the N and K fields.

NOTE – This allows mapping of time expressed in units of *time\_scale* to 90 kHz units, as needed for the calculation of PTS and DTS timestamps, for example in decoders for VVC access units for which no PTS or DTS is encoded in the PES header.

**num\_units\_in\_tick** – This 32-bit field is coded exactly in the same way as the *num\_units\_in\_tick* field in SPS or VPS as defined in 7.3.5 of Rec. ITU-T H.266 | ISO/IEC 23090-3. The information provided by this field shall apply to the entire VVC video stream or VVC highest temporal sublayer representation to which the VVC timing and HRD descriptor is associated.

### 2.6.133 EVC video descriptor

For an EVC video stream, the EVC video descriptor (see Table 2-140) provides basic information for identifying coding parameters, such as profile and level parameters, of that EVC video stream. For an EVC temporal video sub-bitstream, the EVC video descriptor provides information such as the associated EVC highest temporal sub-layer representation contained in the elementary stream to which it applies.

STANDARDSISO.COM : Click to view the full PDF of ISO/IEC 13818-1:2023

Table 2-140 – EVC video descriptor

Syntax	No. of bits	Mnemonic
EVC_video_descriptor() {		
<b>descriptor_tag</b>	8	uimsbf
<b>descriptor_length</b>	16	uimsbf
<b>profile_idc</b>	8	uimsbf
<b>level_idc</b>	8	uimsbf
<b>toolset_idc_h</b>	32	uimsbf
<b>toolset_idc_l</b>	32	uimsbf
<b>progressive_source_flag</b>	1	bslbf
<b>interlaced_source_flag</b>	1	bslbf
<b>non_packed_constraint_flag</b>	1	bslbf
<b>frame_only_constraint_flag</b>	1	bslbf
<b>reserved</b>	1	bslbf
<b>temporal_layer_subset_flag</b>	1	bslbf
<b>EVC_still_present_flag</b>	1	bslbf
<b>EVC_24hr_picture_present_flag</b>	1	bslbf
<b>HDR_WCG_idc</b>	2	uimsbf
<b>reserved</b>	2	bslbf
<b>video_properties_tag</b>	4	uimsbf
if ( temporal_layer_subset_flag == '1' ) {		
<b>reserved</b>	5	bslbf
<b>temporal_id_min</b>	3	uimsbf
<b>reserved</b>	5	bslbf
<b>temporal_id_max</b>	3	uimsbf
}		
}		

#### 2.6.134 Semantic definition of fields in EVC video descriptor

**profile\_idc, level\_idc, toolset\_idc\_h, toolset\_idc\_l** – These fields shall be coded according to the semantics defined in SPS parameters in ISO/IEC 23094-1 for the corresponding EVC video stream.

**progressive\_source\_flag, interlaced\_source\_flag, non\_packed\_constraint\_flag** – These fields shall be coded according to the semantics sei picture timing message defined in ISO/IEC 23094-1 for as indicated by ct\_type.

**frame\_only\_constraint\_flag** – This field shall be coded according to the semantics defined in ISO/IEC 23094-1 for field\_seq\_flag in the VUI parameters for the corresponding EVC video stream.

**temporal\_layer\_subset\_flag** – This 1-bit flag, when set to '1', indicates that the syntax elements describing a subset of temporal layers are included in this descriptor. This field shall be set to 1 for EVC temporal video subsets. When set to '0', the syntax elements temporal\_id\_min and temporal\_id\_max are not included in this descriptor.

**EVC\_still\_present\_flag** – This 1-bit field, when set to '1', indicates that the EVC video stream or the EVC highest temporal sublayer representation may include EVC still pictures. When set to '0', then the associated EVC video stream shall not contain VVC still pictures.

**EVC\_24hr\_picture\_present\_flag** – This flag when set equal to 0 specifies that no long term reference picture (LTRP) is used for inter prediction of any coded picture in the coded video stream (CVS). When set equal to 1, LTRPs may be used for inter prediction of one or more coded pictures in the CVS.

**HDR\_WCG\_idc** – This 2-bit field indicates the presence or absence of high dynamic range (HDR) and/or wide color gamut (WCG) video components in the associated PID according to Table 2-133. This field shall not be set to 2 unless bit\_depth\_luma\_minus8 and bit\_depth\_chroma\_minus8 as defined in ISO/IEC 23094-1 in the associated video is greater than or equal to 2. This information is defined in VUI parameters of Rec. ISO/IEC 23094-1 for the corresponding EVC video stream.

**video\_properties\_tag** – This 4-bit field is used to indicate specific video property CICC combinations for SDR, WCG, or HDR/WCG streams depending on the value of HDR\_WCG\_idc. The CICC values are defined in Rec. ITU-T H.273 | ISO/IEC 23091-2. When HDR\_WCG\_idc is equal to 0, Table 2-135 applies. When HDR\_WCG\_idc is equal to 1, Table 2-136 applies. When HDR\_WCG\_idc is equal to 2, Table 2-137 applies. When HDR\_WCG\_idc is equal to 3, Table 2-138 applies. This information is defined in the VUI parameters of Rec. ISO/IEC 23094-1 for the corresponding EVC video stream.

NOTE 1 – The video\_properties\_tag descriptor can indicate widely used combinations that are documented by ITU-T H.Supp 19 | ISO/IEC TR 23091-4. The system identifiers found in that Supplement | Technical Report are mentioned in Tables 2-135 to 2-138 for convenience.

**temporal\_id\_min** – This 3-bit field indicates the minimum value of the TemporalId, as defined in ISO/IEC 23094-1, of all EVC access units in the associated elementary stream.

**temporal\_id\_max** – This 3-bit field indicates the maximum value of the TemporalId, as defined in ISO/IEC 23094-1, of all EVC access units in the associated elementary stream.

NOTE 2 – These values of temporal\_id\_min and temporal\_id\_max indicate maximum and minimum values, respectively, but they do not guarantee that all temporal layers are present at all times, because the number of temporal layers may change eg. when splicing occurs. However, if the temporal level goes beyond the range given by min and max values, a new descriptor with appropriate values needs to be inserted.

### 2.6.135 EVC timing and HRD descriptor

For an EVC video stream or an EVC temporal video sub-bitstream, the EVC timing and HRD descriptor (see Table 2-141) provides timing and HRD parameters, as defined in Annex C of Rec. ISO/IEC 23094-1, for the associated EVC video stream or the EVC highest temporal sub-layer representation thereof, respectively.

**Table 2-141 – EVC timing and HRD descriptor**

Syntax	No. of bits	Mnemonic
EVC_timing_and_HRD_descriptor() {		
<b>hrd_management_valid_flag</b>	<b>1</b>	<b>bslbf</b>
<b>reserved</b>	<b>6</b>	<b>bslbf</b>
<b>picture_and_timing_info_present_flag</b>	<b>1</b>	<b>bslbf</b>
if (picture_and_timing_info_present_flag == '1') {		
<b>90kHz_flag</b>	<b>1</b>	<b>bslbf</b>
<b>reserved</b>	<b>7</b>	<b>bslbf</b>
if (90kHz_flag == '0') {		
<b>N</b>	<b>32</b>	<b>uimsbf</b>
<b>K</b>	<b>32</b>	<b>uimsbf</b>
}		
<b>num_units_in_tick</b>	<b>32</b>	<b>uimsbf</b>
}		
}		

### 2.6.136 Semantic definition of fields in EVC timing and HRD descriptor

**hrd\_management\_valid\_flag** – This 1-bit flag is only defined for use in transport streams. When the EVC timing and HRD descriptor is associated to an EVC video stream or to an EVC highest temporal sub-layer representation carried in a transport stream, then the following applies.

If the hrd\_management\_valid\_flag is set to '1', then Buffering Period SEI and Picture Timing SEI messages, as defined in Annex C of ISO/IEC 23094-1, shall be present in the associated EVC video stream or EVC highest temporal sub-layer representation. These Buffering Period SEI messages shall carry coded nal\_initial\_cpb\_removal\_delay and nal\_initial\_cpb\_removal\_delay\_offset values and may additionally carry nal\_initial\_alt\_removal\_delay and nal\_initial\_alt\_cpb\_removal\_delay\_offset values for the NAL HRD. If the hrd\_management\_valid\_flag is set to '1', then the transfer of each byte from MB<sub>n</sub> to EB<sub>n</sub> in the T-STD as defined in 2.23.2 or the transfer from MB<sub>n,k</sub> to EB<sub>n</sub> in the T-STD as defined in 2.23.3 shall be according to the delivery schedule for that byte into the CPB in the NAL HRD, as determined from the coded nal\_initial\_cpb\_removal\_delay and nal\_initial\_cpb\_removal\_delay\_offset or from the coded nal\_initial\_alt\_cpb\_removal\_delay and nal\_initial\_alt\_cpb\_removal\_delay\_offset values for SchedSelIdx equal to cpb\_cnt\_minus1 as specified in Annex C of ISO/IEC 23094-1. When the hrd\_management\_valid\_flag is set to '0', the leak method shall be used for the transfer from MB<sub>n</sub> to EB<sub>n</sub> in the T-STD as defined in 2.24.2 or the transfer from MB<sub>n,k</sub> to EB<sub>n</sub> in the T-STD as defined in 2.24.3.

**picture\_and\_timing\_info\_present\_flag** – This 1-bit flag when set to '1' indicates that the 90kHz\_flag and parameters for accurate mapping to 90-kHz system clock are included in this descriptor.

**90kHz\_flag** – This 1-bit flag when set to '1' indicates that the frequency of the EVC time base is 90 kHz.

**N, K** – For an EVC video stream or EVC highest temporal sub-layer representation, the frequency of the EVC time base is defined by the syntax element time\_scale in the SPS, as defined in Annex E of ISO/IEC 23094-1. The relationship between the EVC time\_scale and the STC shall be defined by the parameters N and K in this descriptor as follows.

$$time\_scale = (N \times system\_clock\_frequency) / K$$

If the 90kHz\_flag is set to '1', then N equals 1 and K equals 300. If the 90kHz\_flag is set to '0', then the values of N and K are provided by the coded values of the N and K fields.

NOTE – This allows mapping of time expressed in units of time\_scale to 90 kHz units, as needed for the calculation of PTS and DTS timestamps, for example in decoders for EVC access units for which no PTS or DTS is encoded in the PES header.

**num\_units\_in\_tick** – This 32-bit field is coded exactly in the same way as the num\_units\_in\_tick field in SPS as defined in ISO/IEC 23094-1. The information provided by this field shall apply to the entire EVC video stream or EVC highest temporal sub-layer representation to which the EVC timing and HRD descriptor is associated.

**2.6.137 LCEVC video descriptor**

Table 2-142 provides a description of the LCEVC video descriptor.

**Table 2-142 – LCEVC video descriptor**

Syntax	No. of bits	Mnemonic
LCEVC_video_descriptor() {		
<b>lcevc_stream_tag</b>	8	<b>uimsbf</b>
<b>profile_idc</b>	4	<b>uimsbf</b>
<b>level_idc</b>	4	<b>uimsbf</b>
<b>sublevel_idc</b>	2	<b>uimsbf</b>
<b>processed_planes_type_flag</b>	1	<b>bslbf</b>
<b>picture_type_bit_flag</b>	1	<b>bslbf</b>
<b>field_type_bit_flag</b>	1	<b>bslbf</b>
<b>reserved</b>	3	<b>bslbf</b>
<b>HDR_WCG_idc</b>	2	<b>uimsbf</b>
<b>reserved_zero_2bit</b>	2	<b>bslbf</b>
<b>video_properties_tag</b>	4	<b>uimsbf</b>
}		

**2.6.138 Semantic definition of fields of LCEVC video descriptor**

**lcevc\_stream\_tag** – This is an 8-bit field specifying the identifier of an association between base and enhancement streams of an LCEVC encoding.

**profile\_idc, level\_idc, sublevel\_idc** – These fields shall be coded according to the semantics defined for profile\_idc, level\_idc, sublevel\_idc in 7.3.4 (SC, sequence\_configuration) of ISO/IEC 23094-2.

**processed\_planes\_type\_flag** – This field shall be coded according to the semantics defined for processed\_planes\_type\_flag in 7.3.5 (GC, global\_configuration) of ISO/IEC 23094-2.

**picture\_type\_bit\_flag, field\_type\_bit\_flag** – These fields shall be coded according to the semantics defined for picture\_type\_bit\_flag, field\_type\_bit\_flag in 7.3.6 (PC, picture\_configuration) of ISO/IEC 23094-2.

**HDR\_WCG\_idc** – This 2-bit field indicates the presence or absence of high dynamic range (HDR) and/or wide colour gamut (WCG) video components in the associated PID according to Table 2-134.

**video\_properties\_tag** – This 4-bit field is used to indicate specific widely used video property CICC combinations as indicated by ITU-T H.Supp. 19 | ISO/IEC 23091-4 for SDR, WCG, or HDR/WCG streams depending on the value of HDR\_WCG\_idc. When HDR\_WCG\_idc is equal to 0, Table 2-135 applies. When HDR\_WCG\_idc is equal to 1, Table 2-136 applies. When HDR\_WCG\_idc is equal to 2, Table 2-137 applies. When HDR\_WCG\_idc is equal to 3, Table 2-138 applies.

NOTE 1 – Since the LCEVC enhancement stream and the base video stream that is enhanced are encoded separately, there can be separate values for HDR\_WCG\_idc and HDR\_WCG\_idc in the base and in the enhancement streams, and such values are not necessarily identical.

NOTE 2 – There is no Buffering Period SEI and Picture Timing SEI messages defined for LCEVC because the ones from the base encoding are used. For this reason, LCEVC timing and HRD descriptors are not needed.

**2.6.139 LCEVC linkage descriptor**

Table 2-143 provides a description of the LCEVC linkage descriptor.

Table 2-143 – LCEVC linkage descriptor

Syntax	No. of bits	Mnemonic
LCEVC_linkage_descriptor() { <b>num_lcevc_stream_tags</b> for (i=0; i<num_lcevc_stream_tags; i++) { <b>lcevc_stream_tag</b> } }	8	<b>uimsbf</b>
	8	<b>uimsbf</b>

#### 2.6.140 Semantic definition of fields of LCEVC linkage descriptor

**num\_lcevc\_stream\_tags** – The number of lcevc\_stream\_tag items that will follow.

**lcevc\_stream\_tag** – Tag value that allows indicating this video elementary stream as the base of an LCEVC video stream that carries the same tag value in its LCEVC video descriptor.

#### 2.6.141 Media service kind descriptor

The media\_service\_kind\_descriptor can read on the program or PID ES stream itself or can read on auxiliary PID ES that are dependent on the principal PID media component ES (i.e., in most cases the principal media component is video). The media service kind descriptor can also read upon the entire program to describe content with a single principal media component. Multiple data elements (N) can be included in the descriptor, each with one or more language code/media\_service\_type pairs.

If the same media component is described at a program level and at an elementary level, then the elementary stream media\_service\_kind description shall take precedence.

Table 2-144 provides a description of the media service kind descriptor. The descriptor uses two loops as indicated in Table 2-144. The outer loop can indicate the number of language\_pairs and a unique identifier for the descriptor. The inner loop indicates the language code and its purpose(s).

STANDARDSISO.COM : Click to view the full PDF of ISO/IEC 13818-1:2023

Table 2-144 – Media service kind descriptor

Syntax	No. of bits	Mnemonic
Media_service_kind_descriptor() { for (i=0; i<N; i++) { <b>media_description_flag</b> <b>identifier_flag</b> <b>lang_pairs</b> <b>media_type_idc</b> <b>reserved</b> if (identifier_flag) { <b>ID_length_code</b> <b>ID_type</b> if (ID_length_code == '7') { <b>ID_len</b> } <b>media_ID_field</b> } for (j= 0; j<lang_pairs; j++) { <b>configuration_type</b> <b>lang_purpose_cnt</b> <b>lang_len_idc</b> <b>reserved</b> if (lang_len_idc == 0) { <b>lang_len</b> } <b>IETF_BCP_47_language_code</b> for (k=0; k<lang_purpose_cnt; k++) { <b>media_service_type</b> } } } }	1 1 3 2 1 3 13 8 ID_len*8 2 3 2 1 8 lang_len*8 8	bslbf bslbf uimbsf uimbsf bslbf uimbsf uimbsf uimbsf bslbf uimbsf uimbsf uimbsf bslbf bslbf uimbsf

2.6.142 Semantic definition of fields in media service kind descriptor

**media\_description\_flag** – This flag indicates if the specific entry in the descriptor applies to the elementary stream/program itself or indicates an entry for another stream associated with the elementary stream/program as described in Table 2-145 which is needed to produce a specific purpose of the program.

Table 2-145 – media\_description\_flag

media_description_flag	media_description_flag value
0	self
1	associate

**identifier\_flag** – A flag to indicate if the media\_service\_kind descriptor data element will carry an identifier.

**lang\_pairs** – This field indicates the number of language code/media\_service\_type pairs carried with the data element.

**media\_type\_idc** – This indicator would have the values "0-unknown", "1-Video", "2-Audio" or "3-Text", as indicated in Table 2-146.

Table 2-146 – Media type indicator

media_type_idc	Media type value
0	unknown
1	video
2	audio
3	text/data

**ID\_length\_code** – This parameter assigns to ID\_len the number of bytes from the list of potential byte numbers needed for the carriage of the optional identifier. When the parameter has a value of 7 then the ID\_len can be configured to other byte length numbers. See Table 2-147.

Table 2-147 – ID\_length\_code

Value	Length, bytes ( <i>ID_len</i> )
0	1
1	2
2	4
3	8
4	12
5	16
6	20
7	Explicit value provided in field ID_len

**ID\_type** – Parameter to indicate the type of identifier used according to Table 2-148.

NOTE 1 – This parameter can originate from a list of SCTE UPID identifiers list. Alternatively, identifiers can be reserved outside of the UPID identifiers list.

Table 2-148 – ID\_type

Range	Definition
0x0000 .. 0x01FF	Reserved for MPEG standardization
0x0200 .. 0x02FF	Value defined in ANSI/SCTE 35 Table 22 (segmentation_upid_type) + 0x200
0x0300 .. 0x0FFF	Reserved for MPEG standardization
0x1000 .. 0x1FFF	User Private types

**ID\_len** – The number of bytes needed to carry an optional identifier in the data element of the descriptor.

**media\_ID\_field** – The parameter carrying the identifier in the data element of the descriptor.

**configuration\_type** – This parameter, as defined in Table 2-149, indicates if the elementary stream or associate stream is complete (value= 0, e.g., a 5.1 audio stream) and playable as an independent media component or is partial (value= 1, e.g., M&E or dialogue only) and not playable alone as the media component stream. A complete combination (value= 2, e.g., 5.1/2.0 stream with multiple dialogue languages) contains several variants with each version playable as an independent media component. Internal coding configurations if defined are deferred to the elementary specific format metadata.

Table 2-149 – configuration type values

configuration_type	configuration type value
0	complete
1	partial
2	complete combination
3	reserved

#### configuration\_type value semantics

**complete:** Describes a media component stream that is a single version playable video/audio/text experience otherwise known as complete or complete main.

**partial:** Describes a media component stream that is not a playable video/audio/text experience without additional streams.

**complete combination:** Describes a media component stream that contains multiple playable video/audio/text experiences which can be extracted through different parameter settings.

**lang\_purpose\_cnt** – This parameter indicates the number of media\_service\_types (up to 6) associated with a single language code. If the count is zero it means to use the default media\_service\_type of "und" and if no "main" exists for the track, then this defaults to "main". A value of 7 is reserved for future purposes.

**lang\_len\_idc** – Indicator to determine if a default length is used to indicate the IETF\_BCP\_47\_language\_code field length. If indicator is 0, then char length is assignable by a byte value. When set to 1 or 2, the value of lang\_len is given in Table 2-150. A value of 3 is reserved for future use.

Table 2-150 – lang\_len\_indicator

lang_length_idc	lang_len
0	No default length. Explicit value provided in field lang_len
1	2
2	3
3	reserved

**IETF\_BCP47\_language\_code** – Identifies the language or languages, including sign language, used by the associated program element. The IETF\_BCP47\_language\_code contains a multi-character code as specified by IETF BCP 47 where the number of characters is determined by the value in the preceding lang\_len field. IETF BCP 47 incorporates ISO 639-3 language code with additional description. Each character is coded into 8 bits according to ISO 8859-1 and inserted in order into this field. In the case of multilingual audio streams, the sequence of ISO\_639\_language\_code fields shall reflect the content of the audio stream or designated as 'mul' three-character subtag for dynamic multilingual cases but in the case that the descriptor needs to remain static. In the case of video components that are not sign language, 'zxx' can be used as a three-character primary language subtag.

**media\_service\_type** – This 8-bit field specifies the purpose(s) of the stream(s) described in the descriptor as defined in Table 2-151.

Table 2-151 – Media service type values

Value	Description
0x00	undefined
0x01	main
0x02	alternate
0x03	supplementary
0x04	emergency
0x05	description
0x06	enhanced-audio-intelligibility
0x07	dub
0x08	primary commentary
0x09	primary
0x0A	native
0x0B	Music and effects
0x0C	dialogue
0x0D	voice-over
0x0E	sign
0x0F	multi-view
0x10	karaoke
0x11	caption
0x12	subtitle
0x13	forced-subtitle
0x14	metadata
0x15	non-primary
0x16	substitution
0x17	alternate commentary
0x18	stadium sound

Table 2-151 – Media service type values

Value	Description
0x19 .. 0xEF	Reserved
0xF0 .. 0xFF	User private

**media\_service\_type value semantics****[General]**

**undefined:** This is a default value that indicates that the purpose of the stream is unknown. It is different from the language code "und", which would indicate that the language of the audio is unknown. If "main" is not assigned in the descriptor for the stream, then this defaults to "main".

**main:** Main media component(s) that is/are intended for presentation if no other information is provided.

**alternate:** Media content component(s) that is/are an alternative to (a) main media content component(s) of the same media component type.

**supplementary:** Media content component that is supplementary to a media content component of a different media component type.

**emergency:** Experience that provides information about a current emergency. It is intended to enable the protection of life, health, safety and property, and may also include critical details regarding the emergency and how to respond to the emergency.

**substitution:** Indicates that the media content component is continuous but may have a substitution in language or media\_service\_type that defaults to the main type for that media content component when not available. This often occurs in linear channels where Spanish or audio description may not continuously exist for all programs on the channel, but the linear channel track does need to be continuous.

**[Video specific]**

**sign:** Visual media component representing a sign-language interpretation of an audio component.

**multi-view:** This value indicates that the video stream is an alternate view of the main video feed. This can be used for different sports angle feed in a football game.

**caption:** Textual representation of the audio track usually including both dialogue and all sounds. This text is often embedded in the video track intended for an audience with loss or partial loss of hearing and is in the same language as the dialogue.

**forced-subtitle:** Textual information meant for display when no other text representation is selected. It is used to clarify dialogue, alternative languages, texted graphics or location/person IDs that are not otherwise covered in the dubbed/localized audio.

**[Audio specific]**

**description:** This value indicates that the referenced program element is prepared for the visually impaired viewer. Alternate labels for this are "audio descriptive services" (ADS) or "descriptive video services" (DVS) or "visual impaired commentary".

**enhanced-audio-intelligibility:** Experience containing an element for improved intelligibility of the dialogue. An alternative label for this is "hearing impaired".

**dub:** Experience that contains an element that is presented in a language different from the original (e.g., dubbed audio, translated captions).

**primary commentary:** This value indicates the referenced program element is prepared with narration in addition to the natural sound of the content. This narration can be an announcer to a sporting event or the director's comments on a film or program, and is the default commentary for the content.

**alternate commentary:** This value indicates the referenced program element is prepared as bonus or alternate narration in addition to the natural sound of the content. This additional commentary is of the same language as the primary commentary and can be used for cases such as an additional away announcer to a sporting event or producer's comments of the film or program.

**primary:** This value indicates the default recommended language of the channel or program. This is a separate value from the language code itself. If the language code is Welsh with an undefined `media_service_type`, it means "this is Welsh". When the language code is `welsh` with `media_service_type` `0x09`, it means "this is Welsh, and it is the primary language of this program."

**non-primary:** This value indicates a secondary language of the channel or program. This is a separate value from the language code itself, and indicates a secondary priority of language in the channel or program. Secondary languages may have substitutions in its track when that language is not available in order to provide a continuous track for the channel.

**substitution:** This value indicates the language in the channel or program may be replaced by another language if the language is sometimes unavailable, but the track needs to be continuous with the program. An example of this is a Spanish SAP (secondary audio program) where the commercial does not have a Spanish language track, so an English language track is substituted until the advertisement is done.

**native:** This value indicates the language in which the program was produced. An absence of this value indicates that it is either undefined or a dubbed language.

**Music and effects:** This value indicates that the referenced program element has no language. This can also be known as "clean effects".

**dialogue:** An isolated language track intended to be combined with a music and effects track.

**stadium sound:** Audio track for an event (e.g., sporting event) devoid of any additional commentary. It would be the natural sound one would hear if physically attending the event at the stadium. An alternative term for this would be natural sound.

**voice-over:** An isolated narration track intended to be combined with audio that reflects the natural sound of the scene content.

#### [Text/Data specific]

**dub:** Experience that contains an element that is presented in a language different from the original (e.g., dubbed audio, translated captions).

**commentary:** Experience that contains a commentary (e.g., director's commentary, sports announcer).

**primary:** This value indicates the default recommended textual language of the channel or program. This is a separate value from the language code itself. If the language code is Welsh with an undefined `media_service_type`, it means "this is Welsh subtitles". When the language code is `welsh` with `media_service_type` `0x09`, it means "this is Welsh, and it is the primary subtitles language of this program".

**non-primary:** This value indicates a secondary textual language of the channel or program. This is a separate value from the language code itself and indicates a secondary priority of textual language in the channel or program. Secondary textual languages may have substitutions in its track when that textual language is not available in order to provide a continuous track for the channel.

**native:** This value indicates the language in which the program was produced. An absence of this value indicates that it is either an undefined or a dubbed language.

**karaoke:** Textual representation of a song's lyrics, usually in the same language as the associated songs.

**subtitle:** Textual representation of the audio track. It usually represents only the dialogue and often in a language other than the audio track dialogue. This is intended for a foreign language audience.

**metadata:** Media component containing information intended to be processed by application specific elements.

NOTE 2 – Similar corresponding description values can be found in the definition of the `ISO_639_language` descriptor and in other standards/specifications ISO/IEC 23009-1 (MPEG-DASH), SMPTE ST 2067-2 (IMF Core Constraints), or DASH-IF interoperability points.

Figure 2-4 and Figure 2-5 show examples of the Media Service Kind Descriptor.

<pre>// Program – Media Service Kind Descriptor i=0 // Identify Program   media_description_flag → self   identifier_flag → true   lang_pairs → 0   media_type_idc → content   ID_length_code → 4 (ID_len is 12)   ID_type → 0x20A (EIDR-Content)   media_ID_field → 10.5240/0E4F-892E-442F-6BD4-15B0-1 i=1 // Identify Video   media_description_flag → self   identifier_flag → false   lang_pairs → 2   media_type_idc → video   j=0     configuration_type → complete     lang_purpose_cnt → 0     lang_len_idc → 2 (lang_len = 3)     BCP_47_language_code. → zxx     default // media_service_type → und → main   j=1 // identify Closed Captioning English     configuration_type → complete combination     lang_purpose_cnt → 1     lang_len_idc → 2 (lang_len = 3)     BCP_47_language_code. → eng     k=1 // media_service_type → caption</pre>	<pre>i=2 // Identify Main Audio Track of Linear Channel   media_description_flag → self   identifier_flag → false   lang_pairs → 1   media_type_idc → audio   j=0 // Identify as English Main-Primary-Native     configuration_type → complete     lang_purpose_cnt → 3     len_idc → 2 (lang_len = 3)     BCP_47_language_code. → eng     k=1 // media_service_type → main     k=2 // media_service_type → primary     k=3 // media_service_type → native   i=3 // Identify 2nd Audio Track as Spanish     media_description_flag → self     identifier_flag → false     lang_pairs → 1     media_type_idc → audio     j=0 // Identify as Spanish Main       configuration_type → complete       lang_purpose_cnt → 0       len_idc → 2 (lang_len = 3)       BCP_47_language_code → spa       default // media_service_type → und → main</pre>
--	---

Figure 2-4 – Media Service Kind Descriptor semantics at program level

<pre>// An Audio elementary stream demuxed that has an association to a video track or content i=0 // Identify Audio Elementary Stream   media_description_flag → self   identifier_flag → false   lang_pairs → 1   media_type_idc → audio   j=0 // Identify as English Main-Native     configuration_type → complete     lang_purpose_cnt → 2     len_idc → 2 (lang_len = 3)     BCP_47_language_code → eng     k=1 // media_service_type → main     k=2 // media_service_type → native   i=1 // Associate to Video via identifier     media_description_flag → associate     identifier_flag → true     lang_pairs → 0     media_type_idc → video     ID_length_code → 4 (ID_len is 12)     ID_type → 0x20A (EIDR-Video)     media_ID_field → 10.5239/C370-DCA5</pre>
---

Figure 2-5 – Media Program Kind Descriptor semantics at elementary stream level

## 2.7 Restrictions on the multiplexed stream semantics

### 2.7.1 Frequency of coding the system clock reference

The program stream shall be constructed such that the time interval between the bytes containing the last bit of system\_clock\_reference\_base fields in successive packs shall be less than or equal to 0.7 s. Thus:

$$|t(i) - t(i')| \leq 0.7 \text{ s}$$

for all  $i$  and  $i'$  where  $i$  and  $i'$  are the indexes of the bytes containing the last bit of consecutive system\_clock\_reference\_base fields.

### 2.7.2 Frequency of coding the program clock reference

The transport stream shall be constructed such that the time interval between the bytes containing the last bit of program\_clock\_reference\_base fields in successive occurrences of the PCRs in transport stream packets of the PCR\_PID for each program shall be less than or equal to 0.1 s. Thus:

$$|t(i) - t(i')| \leq 0.1 \text{ s}$$

for all  $i$  and  $i'$  where  $i$  and  $i'$  are the indexes of the bytes containing the last bit of consecutive program\_clock\_reference\_base fields in the transport stream packets of the PCR\_PID for each program.

There shall be at least two (2) PCRs, from the specified PCR\_PID within a transport stream, between consecutive PCR discontinuities (refer to 2.4.3.4) to facilitate phase locking and extrapolation of byte delivery times.

### 2.7.3 Frequency of coding the elementary stream clock reference

The program stream and transport stream shall be constructed such that if the elementary stream clock reference field is coded in any PES packets containing data of a given elementary stream the time interval in the PES\_STD between the bytes containing the last bit of successive ESCR\_base fields shall be less than or equal to 0.7 s. In PES Streams the ESCR encoding is required with the same interval. Thus:

$$|t(i) - t(i')| \leq 0.7 \text{ s}$$

for all  $i$  and  $i'$  where  $i$  and  $i'$  are the indexes of the bytes containing the last bits of consecutive ESCR\_base fields.

NOTE – The coding of elementary stream clock reference fields is optional; they need not be coded. However, if they are coded, this constraint applies.

### 2.7.4 Frequency of presentation timestamp coding

The program stream and transport stream shall be constructed so that the maximum difference between coded presentation timestamps referring to each elementary video or audio stream is 0.7 s. Thus:

$$|tp_n(k) - tp_n(k'')| \leq 0.7 \text{ s}$$

for all  $n$ ,  $k$ , and  $k''$  satisfying:

- $P_n(k)$  and  $P_n(k'')$  are presentation units for which presentation timestamps are coded;
- $k$  and  $k''$  are chosen so that there is no presentation unit,  $P_n(k')$  with a coded presentation timestamp and with  $k < k' < k''$ ; and
- No decoding discontinuity exists in elementary stream  $n$  between  $P_n(k)$  and  $P_n(k'')$ .

The 0.7-s constraint does not apply in the case of:

- still pictures as defined in 2.1;
- AVC still pictures;
- AVC access units with a very low frame rate, where the presentation time of subsequent access units differs by more than 0.7 s. In this particular case, the VUI parameters num\_units\_in\_tick and time\_scale shall be present either in the AVC video stream or in an AVC-timing and HRD descriptor associated with the AVC video stream.

NOTE – The presentation time of an AVC access unit is equivalent to the DPB output time  $t_{o,dpb}(n)$  defined in Annex C of Rec. ITU-T H.264 | ISO/IEC 14496-10.

## 2.7.5 Conditional coding of timestamps

For each elementary stream of a program stream or transport stream, a presentation timestamp (PTS) shall be encoded for the first access unit.

A decoding discontinuity exists at the start of an access unit  $A_n(j)$  in an elementary stream  $n$  if the decoding time  $td_n(j)$  of that access unit is greater than the largest value permissible given the specified tolerance on the system\_clock\_frequency. For video, except when trick mode status is true or when low\_delay flag is '1', this is allowed only at the start of a video sequence. If a decoding discontinuity exists in any elementary video or audio stream in the transport stream or program stream, then a PTS shall be encoded referring to the first access unit after each decoding discontinuity except when trick mode status is true.

When low\_delay is '1' a PTS shall be encoded for the first access unit after an  $EB_n$  or  $B_n$  underflow.

A PTS may only be present in a Rec. ITU-T H.222.0 | ISO/IEC 13818-1 video or audio elementary stream PES packet header if the first byte of a picture start code or the first byte of an audio access unit is contained in the PES packet.

A decoding\_timestamp (DTS) shall appear in a PES packet header if and only if the following two conditions are met:

- a PTS is present in the PES packet header;
- the decoding time differs from the presentation time.

For each AVC 24-hour picture, no explicit PTS and DTS value shall be encoded in the PES header. For such AVC access unit, decoders shall infer the presentation time from the parameters within the AVC video stream. Therefore, each AVC video stream that contains one or more AVC 24-hour picture(s):

- shall either carry picture timing SEI messages with coded values of `cpb_removal_delay` and `dpb_output_delay`; or
- shall carry VUI parameters with the `fixed_frame_rate_flag` set to '1' and shall carry Picture Order Count (POC) information (`PicOrderCnt`) whereby pictures are counted in units of  $\Delta t_{fi,dpb}(n)$ , where  $\Delta t_{fi,dpb}(n)$  is specified in equation E-10 of Rec. ITU-T H.264 | ISO/IEC 14496-10.

NOTE 1 – The requirements in the second bullet are met if an AVC timing and HRD descriptor is associated with the AVC video stream with the `fixed_frame_rate_flag` set to '1' and the `temporal_poc_flag` set to '1'.

The following applies to AVC access units in an AVC video stream carried in a Rec. ITU-T H.222.0 | ISO/IEC 13818-1 stream. For each AVC access unit that does not represent an AVC 24-hour picture, a PES header with a coded PTS and, if applicable, DTS value shall be provided, unless all conditions expressed under one of the following four bullets are true:

- In the AVC video sequence the following SEI messages are present, as signalled by VUI parameters:
  - a) picture timing SEI messages providing the `cpb_removal_delay` and the `dpb_output_delay` parameters; and
  - b) buffering period SEI messages providing the `initial_cpb_removal_delay` and the `initial_cpb_removal_delay_offset` parameters.

NOTE 2 – When picture timing SEI messages are present in the AVC video sequence, then these messages are present for each AVC access unit, as required by Rec. ITU-T H.264 | ISO/IEC 14496-10. When buffering period SEI messages are present in the AVC video sequence, then these messages shall be present for each IDR access unit and for each access unit that is associated with a recovery point SEI message, as required by Rec. ITU-T H.264 | ISO/IEC 14496-10.

- An AVC timing and HRD descriptor is associated with the AVC video stream and in this descriptor the `fixed_frame_rate_flag` is set to '1' and the `temporal_poc_flag` is set to '1'.
- An AVC timing and HRD descriptor is associated with the AVC video stream and in this descriptor the `fixed_frame_rate_flag` is set to '1', the `picture_to_display_conversion_flag` is set to '1', the `temporal_poc_flag` is set to '0' and in the AVC video sequence picture timing SEI messages with the `pic_struct` field are present.

NOTE 3 – In this specific case the `pic_struct` field is used to determine subsequent PTS values.

- An AVC timing and HRD descriptor is associated with the AVC video stream and in this descriptor the `fixed_frame_rate_flag` is set to '1' and the `temporal_poc_flag` is set to '0' and the `picture_to_display_conversion_flag` is set to '0'.

NOTE 4 – In this case the POC information in the AVC video stream is used to determine the subsequent PTS values.

### 2.7.6 Timing constraints for scalable coding

If an audio sequence is coded using an extension bitstream, such as specified in ISO/IEC 13818-3, then corresponding decoding/presentation units in the two layers shall have identical PTS values.

If a video sequence is coded as an SNR enhancement of another sequence, such as specified in 7.8 of Rec. ITU-T H.262 | ISO/IEC 13818-2, then the set of presentation times for both sequences shall be the same.

If a video sequence is coded as two partitions, such as specified in 7.10 of Rec. ITU-T H.262 | ISO/IEC 13818-2, then the set of presentation times for both partitions shall be the same.

If a video sequence is coded as a spatial scalable enhancement of another sequence, such as specified in 7.7 of Rec. ITU-T H.262 | ISO/IEC 13818-2, then the following shall apply:

- If both sequences have the same frame rate, the set of presentation times for both sequences shall be the same.
 

NOTE – This does not imply that the picture coding type is the same in both layers.
- If the sequences have different frame rates, the set of presentation times shall be such that as many presentation times as possible shall be common to both sequences.
- The picture from which the spatial prediction is made shall be one of the following:
  - the coincident or most recently decoded lower layer picture;
  - the coincident or most recently decoded lower layer picture that is an I- or P-picture;
  - the second most recently decoded lower layer picture that is an I- or P-picture, and provided that the lower layer does not have the low\_delay flag set to '1'.

If a video sequence is coded as a temporally scalable enhancement of another sequence, such as specified in 7.9 of Rec. ITU-T H.262 | ISO/IEC 13818-2, then the following lower layer pictures may be used as the reference. Times are relative to presentation times of:

- the coincident or most recently presented lower layer picture;
- the next lower layer picture to be presented.

For AVC video streams conforming to one or more profiles defined in Annex G of Rec. ITU-T H.264 | ISO/IEC 14496-10, there are no timing constraints on SVC dependency representations or re-assembled AVC access units of video sub-bitstreams of an AVC video stream.

### 2.7.7 Frequency of coding P-STD\_buffer\_size in PES packet headers

In a program stream, the P-STD\_buffer\_scale and P-STD\_buffer\_size fields shall occur in the first PES packet of each elementary stream and again whenever the value changes. They may also occur in any other PES packet.

### 2.7.8 Coding of system header in the program stream

In a program stream, the system header may be present in any pack, immediately following the pack header. The system header shall be present in the first pack of a program stream. The values encoded in all the system headers in the program stream shall be identical.

### 2.7.9 Constrained system parameter program stream

A program stream is a "Constrained System Parameters Stream" (CSPS) if it conforms to the bounds specified in this subclause. Program streams are not limited to the bounds specified by the CSPS. A CSPS may be identified by means of the CSPS\_flag defined in the system header in 2.5.3.5. The CSPS is a subset of all possible program streams.

#### Packet rate

In the CSPS, the maximum rate at which packets shall arrive at the input to the P-STD is 300 packets per second if the value encoded in the rate\_bound field (refer to 2.5.3.6) is less than or equal to 4 500 000 bits/s if the packet\_rate\_restriction\_flag is set to '1', and less than or equal to 2 000 000 bits/s if the packet\_rate\_restriction\_flag is set to '0'. For higher bit rates the CSPS packet rate is bounded by a linear relation to the value encoded in the rate\_bound field.

Specifically, for all packs  $p$  in the program stream when the packet\_rate\_restriction\_flag (refer to 2.5.3.5) is set to a value of '1',

$$NP \leq (t(i') - t(i)) \times 300 \times \max \left[ 1, \frac{R_{\max}}{4.5 \times 10^6} \right] \quad (2-27)$$

and if the `packet_rate_restriction_flag` is set to a value of '0'

$$NP \leq (t(i') - t(i)) \times 300 \times \max \left[ 1, \frac{R_{\max}}{2.5 \times 10^6} \right] \quad (2-28)$$

where:

$$R_{\max} = 8 \times 50 \times \text{rate\_bound} \quad \text{bit/s} \quad (2-29)$$

$NP$  is the number of `packet_start_code_prefixes` and `system_header_start_codes` between adjacent `pack_start_codes` or between the last `pack_start_code` and the `MPEG_program_end_code` as defined in Table 2-37 and semantics in 2.5.3.2.

$t(i)$  is the time, measured in seconds, encoded in the SCR of pack  $p$ .

$t(i')$  is the time, measured in seconds, encoded in the SCR for pack  $p + 1$ , immediately following pack  $p$ , or in the case of the final pack in the program stream, the time of arrival of the byte containing the last bit of the `MPEG_program_end_code`.

### Decoder buffer size

In the case of a CSPTS the maximum size of each input buffer in the system target decoder is bounded. Different bounds apply for video elementary streams and audio elementary streams.

In the case of a Rec. ITU-T H.262 | ISO/IEC 13818-2 or ISO/IEC 11172-2 video elementary stream in a CSPTS, the following applies:

$BS_n$  has a size which is equal to the sum of the size of the Video Buffer Verifier (VBV) as specified in the Rec. ITU-T H.262 | ISO/IEC 13818-2 or ISO/IEC 11172-2 stream, respectively, and an additional amount of buffering  $BS_{add}$ .  $BS_{add}$  is specified as:

$$BS_{add} \leq \text{MAX} [6 \times 1024, R_{vmax} \times 0.001] \text{ bytes}$$

where  $R_{vmax}$  is the maximum bit rate of the Rec. ITU-T H.262 | ISO/IEC 13818-2 or ISO/IEC 11172-2 video elementary stream.

In the case of a Rec. ITU-T H.264 | ISO/IEC 14496-10 video elementary stream in a CSPTS, the following applies:

$BS_n$  has a size which is equal to the sum of `cpb_size` and an additional amount of buffering  $BS_{add}$ .  $BS_{add}$  is specified as:

$$BS_{add} \leq \text{MAX} [6 \times 1024, R_{vmax} \times 0.001] \text{ bytes}$$

where  $R_{vmax}$  is the maximum video bit rate of the AVC video stream, and

where `cpb_size` is the `CpbSize[ept_cnt_minus1]` size of the CPB for the byte stream format signalled in the NAL `hrd_parameters()` in the AVC video stream. If the NAL `hrd_parameters()` are not present in the AVC video stream, then the `cpb_size` shall be the size defined as  $1200 \times \text{MaxCPB}$  in Annex A of Rec. ITU-T H.264 | ISO/IEC 14496-10 for the applied level.

In the case of an audio elementary stream in a CSPTS, unless otherwise specified below, the following applies:

$$BS_n \leq 4096 \text{ bytes}$$

In the case of ISO/IEC 13818-7 ADTS audio elementary stream in a CSPTS the following applies to support 8 channels:

$$BS_n \leq 8976 \text{ bytes}$$

### 2.7.10 Transport stream

#### Sample rate locking in transport streams

In the transport stream there shall be a specified constant rational relationship between the audio sampling rate and the system clock frequency in the system target decoder, and likewise a specified rational relationship between the video frame rate and the system clock frequency. The `system_clock_frequency` is defined in 2.4.2.1. The video frame rate is specified in Rec. ITU-T H.262 | ISO/IEC 13818-2 or in ISO/IEC 11172-2. The audio sampling rate is specified in ISO/IEC 13818-3 or in ISO/IEC 11172-3. For all presentation units in all audio elementary streams in the transport stream, the

ratio of system\_clock\_frequency to the actual audio sampling rate, SCASR, is constant and equal to the value indicated in the following table at the nominal sampling rate indicated in the audio stream.

$$SCASR = \frac{\text{system\_clock\_frequency}}{\text{audio\_sample\_rate\_in\_the\_T - STD}} \quad (2-30)$$

The notation  $\frac{X}{Y}$  denotes real division.

Nominal audio sampling frequency (kHz)	16	32	22.05	44.1	24	48
SCASR	$\frac{27\ 000\ 000}{16\ 000}$	$\frac{27\ 000\ 000}{32\ 000}$	$\frac{27\ 000\ 000}{22\ 050}$	$\frac{27\ 000\ 000}{44\ 100}$	$\frac{27\ 000\ 000}{24\ 000}$	$\frac{27\ 000\ 000}{48\ 000}$

For all presentation units in each ISO/IEC 11172-2 video and Rec. ITU-T H.262 | ISO/IEC 13818-2 video stream in the transport stream, the ratio of system\_clock\_frequency to the actual video frame rate, SCFR, is constant and equal to the value indicated in the following table at the nominal frame rate indicated in the video stream.

$$SCFR = \frac{\text{system\_clock\_frequency}}{\text{frame\_rate\_in\_the\_T - STD}} \quad (2-31)$$

Nominal frame rate (Hz)	23.976	24	25	29.97	30	50	59.94	60
SCFR	1 126 125	1 125 000	1 080 000	900 900	900 000	540 000	450 450	450 000

The values of the SCFR are exact. The actual frame rate differs slightly from the nominal rate in cases where the nominal rate is 23.976, 29.97, or 59.94 frames per second.

For ISO/IEC 14496-2 video streams carried in a transport stream, the time base of the ISO/IEC 14496-2 video stream, as defined by vop\_time\_increment\_resolution, shall be locked to the STC and shall be exactly equal to N times system\_clock\_frequency divided by K, with N and K integers that have a fixed value within each visual object sequence, with K greater than or equal to N.

For Rec. ITU-T H.264 | ISO/IEC 14496-10 video streams, the time base of the Rec. ITU-T H.264 | ISO/IEC 14496-10 video stream shall be locked to the system clock frequency. The frequency of the AVC time base is defined by the AVC parameter time\_scale, and this frequency shall be exactly equal to N times system\_clock\_frequency divided by K, with N and K integers that have a fixed value within each AVC video sequence and K greater than or equal to N. For example, if the time\_scale is set to 90 000, then the frequency of the AVC time base is exactly equal to system\_clock\_frequency divided by 300.

## 2.8 Compatibility with ISO/IEC 11172

The program stream of this Recommendation | International Standard is defined to be forward compatible with ISO/IEC 11172-1. Decoders of the program stream as defined in this Recommendation | International Standard shall also support decoding of ISO/IEC 11172-1.

## 2.9 Registration of copyright identifiers

### 2.9.1 General

Parts 1, 2 and 3 of ISO/IEC 13818 provide support for the management of audiovisual works copyrighting. In Rec. ITU-T H.222.0 | ISO/IEC 13818-1 this is by means of a copyright descriptor, while Rec. ITU-T H.262 | ISO/IEC 13818-2 and ISO/IEC 13818-3 contain fields for identifying copyright holders through syntax fields in the elementary stream syntax. This Recommendation | International Standard presents the method of obtaining and registering copyright identifiers in Rec. ITU-T H.222.0 | ISO/IEC 13818-1.

Rec. ITU-T H.222.0 | ISO/IEC 13818-1 specifies a unique 32-bit copyright\_identifier which is a work type code identifier (such as ISBN, ISSN, ISRC, etc.) carried in the copyright descriptor. The copyright\_identifier enables identification of a wide number of Copyright Registration Authorities. Each Copyright Registration Authority may specify a syntax and semantic for identifying the audiovisual works or other copyrighted works within that particular copyright organization through appropriate use of the variable length additional\_copyright\_info field which contains the copyright number.

In the following subclause and Annexes L, M and N, the benefits and responsibilities of all parties to the registration of `copyright_identifier` are outlined.

### 2.9.2 Implementation of a Registration Authority (RA)

ISO/IEC JTC 1 shall call for nominations for an international organization which will serve as the Registration Authority for the **copyright\_identifier** as defined in 2.6.24. The selected organization shall serve as the Registration Authority. The so-named Registration Authority shall execute its duties in compliance with Annex H/JTC 1 Directives. The registered `copyright_identifier` is hereafter referred to as the Registered Identifier (RID).

Upon selection of the Registration Authority, JTC 1 shall require the creation of a Registration Management Group (RMG) which will review appeals filed by organizations whose request for a RID to be used in conjunction with Rec. ITU-T H.222.0 | ISO/IEC 13818-1 has been denied by the Registration Authority.

Annexes L, M and N provide information on the procedure for registering a unique copyright identifier.

## 2.10 Registration of private data format

The registration descriptor of Rec. ITU-T H.222.0 | ISO/IEC 13818-1 is provided by this text in order to enable users of this Specification to unambiguously carry data when its format is not recognized by this Specification. This provision will permit this Specification to carry all types of data while providing for a method of unambiguous identification of the characteristics of the underlying private data.

### 2.10.1 General

In the following subclause and Annexes O and P, the benefits and responsibilities of all parties to the registration of private data format are outlined.

### 2.10.2 Implementation of a Registration Authority (RA)

ISO/IEC JTC 1/SC 29 shall call for nominations from member bodies of ISO or National Committees of IEC which will serve as the Registration Authority for the **format\_identifier** as defined in 2.6.8 and 2.6.9. The selected organization shall serve as the Registration Authority. The so-named Registration Authority shall execute its duties in compliance with Annex H/JTC 1 Directives. The registered private data format identifier is hereafter referred to as the Registered Identifier (RID).

Upon selection of the Registration Authority, JTC 1 shall require the creation of a Registration Management Group (RMG) which will review appeals filed by organizations whose request for an RID to be used in conjunction with this Specification has been denied by the Registration Authority.

Annexes O and P provide information on the procedures for registering a unique format identifier.

## 2.11 Carriage of ISO/IEC 14496 data

### 2.11.1 Introduction

A Rec. ITU-T H.222.0 | ISO/IEC 13818-1 stream may carry individual ISO/IEC 14496-2 and 14496-3 elementary streams as well as ISO/IEC 14496-1 audiovisual scenes with its associated streams. Typically, the ISO/IEC 14496 streams will be elements of a Rec. ITU-T H.222.0 | ISO/IEC 13818-1 program, as defined by the PMT in a transport stream and the PSM in a program stream.

For the carriage of ISO/IEC 14496 data in transport streams and program streams, distinction is made between individual elementary streams and an ISO/IEC 14496-1 audiovisual scene with its associated streams. For carriage of individual ISO/IEC 14496-2 and 14496-3 elementary streams, only system tools from Rec. ITU-T H.222.0 | ISO/IEC 13818-1 are used, as defined in 2.11.2. For carriage of an audiovisual ISO/IEC 14496-1 scene and associated ISO/IEC 14496 elementary streams, contained in ISO/IEC 14496-1 SL\_packetized streams or M4Mux streams, tools from both Rec. ITU-T H.222.0 | ISO/IEC 13818-1 and from ISO/IEC 14496-1 are used, as defined in 2.11.3.

Carriage of Rec. ITU-T H.264 | ISO/IEC 14496-10 video over Rec. ITU-T H.222.0 | ISO/IEC 13818-1 streams is specified in 2.14.

Carriage of ISO/IEC 14496-17 text streams over Rec. ITU-T H.222.0 | ISO/IEC 13818-1 streams is specified in 2.15.

### 2.11.2 Carriage of individual ISO/IEC 14496-2 and 14496-3 Elementary Streams in PES packets

#### 2.11.2.1 Introduction

Individual ISO/IEC 14496-2 and 14496-3 elementary streams may be carried in PES packets as `PES_packet_data_bytes`. For PES packetization no specific data alignment constraints apply. For synchronization PTSs and, when appropriate,

DTSs are encoded in the header of the PES packet that carries the ISO/IEC 14496 elementary stream data; for PTS and DTS encoding the same constraints apply as for ISO/IEC 13818 elementary streams. See Table 2-152 for an overview of how to carry individual ISO/IEC 14496 streams within a Rec. ITU-T H.222.0 | ISO/IEC 13818-1 stream.

**Table 2-152 – Carriage of individual ISO/IEC 14496 streams in Rec. ITU-T H.222.0 | ISO/IEC 13818-1**

ISO/IEC 14496-2 visual	Carriage in PES packets	Stream_type = 0x10	Stream_id = '1110 xxxx'
ISO/IEC 14496-3 audio	Carriage in PES packets	Stream_type = 0x11	Stream_id = '110x xxxx'

If a PTS or DTS is present in the PES packet header it shall refer to the visual object that follows either the first VOP start code or the first still texture object startcode that commences in the PES packet. Each ISO/IEC 14496-2 video stream carried by Rec. ITU-T H.222.0 | ISO/IEC 13818-1 shall contain the information required to decode the ISO/IEC 14496-2 video stream; consequently, the stream shall contain Visual Object Sequence Headers, Visual Object Headers and Video Object Layer Headers.

In the case of an ISO/IEC 14496-3 elementary stream signalled by a stream\_type value of 0x11, before PES packetization the elementary stream data shall be first encapsulated in the LATM transport syntax defined in ISO/IEC 14496-3. In such a case, if a PTS is present in the PES packet header it shall refer to the first audio frame that follows the first syncword that commences in the payload of the PES packet.

In the case of an ISO/IEC 14496-3 elementary stream signalled by a stream\_type value of 0x1C, the first byte of each audio frame shall be the first byte of the payload of a PES packet; prior to PES packetization no encapsulation in any additional transport syntax shall be applied. An audio frame from an ISO/IEC 14496-3 elementary stream signalled by a stream\_type value of 0x1C may be fragmented for carriage in multiple PES packets. In the PES packet header the data\_alignment\_indicator shall be set to '1' in each PES packet that carries a complete such audio frame or the first fragment thereof. The data\_alignment\_indicator shall be set to '0' for PES packets carrying subsequent (non-first) fragments of an audio frame.

Carriage of individual ISO/IEC 14496-2 and ISO/IEC 14496-3 elementary streams in PES packets shall be identified by appropriate stream\_id and stream\_type values, indicating the use of ISO/IEC 14496-2 Visual or 14496-3 Audio. In addition, such carriage shall be signalled by the MPEG-4\_video descriptor or MPEG-4\_audio descriptor, respectively. These descriptors shall be conveyed in the descriptor loop for the respective elementary stream entry in the Program Map Table in case of a transport stream or in the Program Stream Map, when present, in case of a program stream. Rec. ITU-T H.222.0 | ISO/IEC 13818-1 does not specify presentation of ISO/IEC 14496-2 and ISO/IEC 14496-3 elementary streams in the context of a program.

Carriage of an individual ISO/IEC 14496-17 text streams in PES packets shall be identified by appropriate stream\_id and stream\_type values, indicating the use of ISO/IEC 14496-17 text.

**2.11.2.2 STD extensions for individual ISO/IEC 14496 elementary streams**

The T-STD model includes a transport buffer  $TB_n$  and a multiplex buffer  $B_n$  prior to decoding of each individual ISO/IEC 14496 elementary stream  $n$ . Note that in the T-STD the single multiplex buffer  $B_n$  is also applied for ISO/IEC 14496-2 video, as indicated in Figure 2-6, instead of the approach with two buffers  $MB_n$  and  $EB_n$  used for ISO/IEC 13818-2 video in the T-STD. For buffers  $TB_n$  and  $B_n$  and the rate  $R_{X_n}$  between  $TB_n$  and  $B_n$  the following constraints apply.

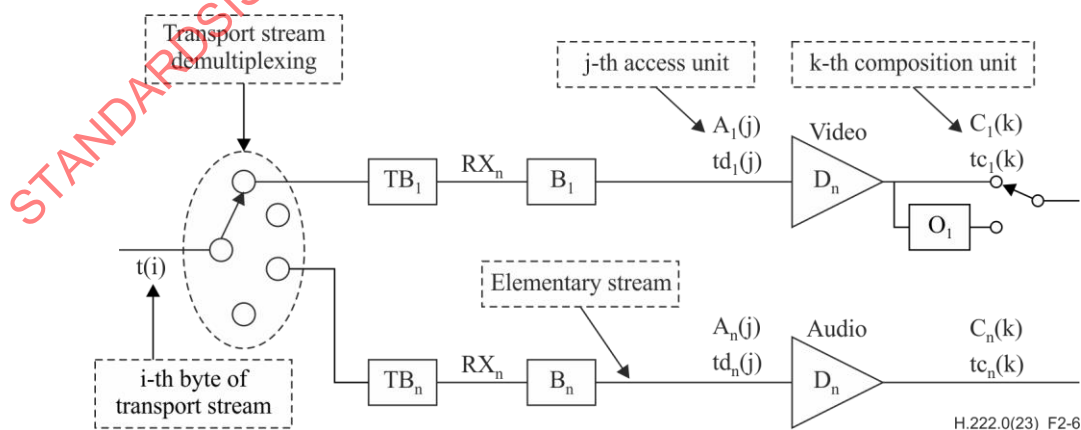

**Figure 2-6 – T-STD model extensions for individual ISO/IEC 14496 elementary streams**

In case of carriage of an ISO/IEC 14496-2 stream:

Size  $BS_n$  of Buffer  $B_n$ :

$$BS_n = BS_{\text{mux}} + BS_{\text{oh}} + VBV_{\text{max}}[\text{profile,level}]$$

where:

$BS_{\text{oh}}$ , packet overhead buffering, is defined as:

$$BS_{\text{oh}} = (1/750) \text{ seconds} \times \max\{R_{\text{max}}[\text{profile,level}], 2\,000\,000 \text{ bit/s}\}$$

and:

$BS_{\text{mux}}$ , additional multiplex buffering, is defined as:

$$BS_{\text{mux}} = 0.004 \text{ seconds} \times \max\{R_{\text{max}}[\text{profile,level}], 2\,000\,000 \text{ bit/s}\}$$

Rate  $R_{x_n}$ :

$$R_{x_n} = 1.2 \times R_{\text{max}}[\text{profile,level}]$$

where:

$VBV_{\text{max}}[\text{profile,level}]$  and  $R_{\text{max}}[\text{profile,level}]$  are defined in ISO/IEC 14496-2 for each profile and level. For profiles and levels for which no  $VBV_{\text{max}}$  value is specified, the size of  $B_n$  and the rate  $R_{x_n}$  are user defined.

For carriage of an ISO/IEC 14496-3 audio stream the following applies.

Size  $BS_n$  of Buffer  $B_n$ , whereby  $BS_n = BS_{\text{mux}} + BS_{\text{dec}} + BS_{\text{oh}}$ :

For ISO/IEC 14496-3 audio, except for ISO/IEC 14496-3 DST, ALS and SLS:

$BS_n = 3584$  bytes if 1-2 channels

Here, the size of the access unit decoding buffer  $BS_{\text{dec}}$ , and the PES packet overhead buffer  $BS_{\text{oh}}$  are constrained by:  $BS_{\text{dec}} + BS_{\text{oh}} \leq 2848$  bytes; a portion (736 bytes) of the 3584 byte buffer is allocated for buffering to allow multiplexing. The rest, 2848 bytes, are shared for access unit buffering  $BS_{\text{dec}}$ ,  $BS_{\text{oh}}$  and additional multiplexing.

$BS_n = 8976$  bytes if 3-8 channels

$BS_n = 12804$  bytes if 9-12 channels

$BS_n = 51216$  bytes if 13-48 channels

For ISO/IEC 14496-3 DST-64, ALS and SLS audio:

if number of audio channels  $\leq 8$  then  $BS_n = 1\,600\,000$  bytes,  
else  $BS_n = 200\,000 \times (\text{number of audio channels})$  bytes.

For ISO/IEC 14496-3 DST-128 audio:

$BS_n = 400\,000 \times (\text{number of audio channels})$  bytes.

For ISO/IEC 14496-3 DST-256 audio:

$BS_n = 800\,000 \times (\text{number of audio channels})$  bytes.

Rate  $R_{x_n}$ :

For ISO/IEC 14496-3 audio, except for ISO/IEC 14496-3 DST, ALS and SLS:

$R_{x_n} = 2\,000\,000$  bit/s if 1-2 channels

$R_{x_n} = 5\,529\,600$  bit/s if 3-8 channels

$R_{x_n} = 8\,294\,400$  bit/s if 9-12 channels

$R_{x_n} = 33\,177\,600$  bit/s if 13-48 channels

For ISO/IEC 14496-3 DST-64, ALS and SLS audio:

if number of audio channels  $\leq 8$  then  $R_{x_n} = 30\,000\,000$  bit/s,  
else  $R_{x_n} = 120\,000\,000$  bit/s.

For ISO/IEC 14496-3 DST-128 and DST-256 audio:

$R_{x_n} = 120\,000\,000$  bit/s.

The P-STD model includes a multiplex buffer  $B_n$  prior to decoding of each individual ISO/IEC 14496 elementary stream  $n$ . The size  $BS_n$  of buffer  $B_n$  in the P-STD is defined by the P-STD\_buffer\_size field in the PES packet header.

### 2.11.3 Carriage of audiovisual ISO/IEC 14496-1 scenes and associated ISO/IEC 14496 streams

#### 2.11.3.1 Introduction

This clause describes the encapsulation and signalling when an audiovisual scene represented by ISO/IEC 14496 data is carried in a Rec. ITU-T H.222.0 | ISO/IEC 13818-1 program stream or transport stream. ISO/IEC 14496 content consists of the initial object descriptor and a variable number of streams such as object descriptor streams, scene description streams (carrying either BIFS-Command or BIFS-Anim access units), IPMP streams, OCI streams and audiovisual streams. Each of the ISO/IEC 14496 streams shall be contained in an SL-packetized stream and may optionally be multiplexed into a M4Mux stream, both defined in ISO/IEC 14496-1. For carriage in Rec. ITU-T H.222.0 | ISO/IEC 13818-1 program stream or transport stream, these SL-packetized streams and M4Mux streams shall contain encoded Object Clock Reference (OCR) and M4Mux Clock Reference (FCR) fields as specified in 2.11.3.4 and in 2.11.3.5, respectively. The SL-packetized streams or M4Mux streams are then encapsulated either in PES packets or in ISO\_IEC\_14496\_sections prior to transport stream packetization and multiplexing or program stream multiplexing. ISO\_IEC\_14496\_sections are built on the long format of H.222.0 | ISO/IEC 13818-1 sections.

Additionally, an ISO/IEC 14496 audiovisual scene may refer to non SL-Packetized streams carried in an Rec. ITU-T H.222.0 | ISO/IEC 13818-1 transport stream using a "pid://PID\_NUMBER" URL scheme instead of a "od://OD\_ID" URL scheme.

ISO/IEC 14496 streams may derive their time base from the PCR of the program through the OCR\_ES\_ID mechanism.

#### 2.11.3.2 Assignment of ES\_ID values

An ISO/IEC 14496-1 scene carried over a Rec. ITU-T H.222.0 | ISO/IEC 13818-1 stream may associate a number of ISO/IEC 14496, ISO/IEC 13818 and other streams by the use of the ES\_ID parameter. The scene and the associated streams may be carried over the same Rec. ITU-T H.222.0 | ISO/IEC 13818-1 stream, but a scene may also reference streams carried elsewhere, for example over an IP network. How to identify such other means is not defined in this Specification.

ISO/IEC 14496-1 defines name scoping rules for identifiers. These rules allow the same ES\_ID value to be used for two different streams within ISO/IEC 14496 content. When one or multiple ISO/IEC 14496-1 scenes are carried in a Rec. ITU-T H.222.0 | ISO/IEC 13818-1 Program, duplicate ES\_ID values shall not occur within the program such that each ISO/IEC 14496 SL-packetized stream or ISO/IEC 14496-1 M4Mux channel has a unique ES\_ID value in the program.

#### 2.11.3.3 Timing of ISO/IEC 14496 scenes and associated streams

When carried over a Rec. ITU-T H.222.0 | ISO/IEC 13818-1 stream, the object time base of each ISO/IEC 14496 stream shall be locked to the Rec. ITU-T H.222.0 | ISO/IEC 13818-1 STC, that is:

$$\text{If } X(t) = f_{\text{stc}}(t)/f_{\text{object}}(t)$$

then the value of  $X(t)$  shall be constant at any time  $t$ .

where:

- $f_{\text{stc}}(t)$  denotes the intended frequency of the STC at time  $t$ , i.e., 27 000 000 Hz
- $f_{\text{object}}(t)$  denotes the frequency of the object time base at time  $t$

The object time base of ISO/IEC 14496 streams carried over a Rec. ITU-T H.222.0 | ISO/IEC 13818-1 stream is conveyed as follows:

- The object time base of an SL-packetized stream carried in PES packets without the use of the M4Mux shall be conveyed by coded OCRs in the SL packet header of that stream. See 2.11.3.4.
- The object time base of SL-packetized streams carried in PES packets within a M4Mux stream shall be conveyed by FCRs in that M4Mux stream. See 2.11.3.5. Consequently, all ISO/IEC 14496 streams contained within the same M4Mux stream share the same object time base.
- The object time base of an SL-packetized stream carried in sections shall be conveyed by another ISO/IEC 14496 stream within the transport stream or program stream as indicated by the OCR\_ES\_ID field in the ES descriptor for that stream.
- The object time base of an SL-packetized stream whose OCR\_ES\_ID identifies a non SL-packetized stream with a PID equal to the PCR PID is  $f_{\text{stc}}(t) / 300$

The following constraints shall apply for encoding of OCRs and FCRs in SL-packetized streams and M4Mux streams carried over a Rec. ITU-T H.222.0 | ISO/IEC 13818-1 stream:

- The OCRs and FCRs in each SL-packetized stream and each M4Mux stream associated with the same scene shall have the same resolution.
- The resolution of OCRs and FCRs for a scene,  $f_{cr}$ , shall have a value smaller than or equal to 90 000 Hz.
- The ratio  $(f_{stc}(t)/300)/f_{cr}$ , shall be an integer value larger than or equal to one. Consequently the resolution of the OCR and FCR syntax elements may only take values such as 90 000 Hz, 45 000 Hz, 30 000 Hz, 22 500 Hz, 18 000 Hz, etc.

Within the above constraints and the ISO/IEC 14496-1 constraint that the resolution  $f_{cr}$  shall represent an integer number of cycles per second,  $f_{cr}$  can be selected as appropriate for the scene.

The ISO/IEC 14496 time stamps coded in the SL packet header shall refer to instants of the object time base of the stream carried in the SL packet. The resolution of each such time stamp shall be of a factor  $2^k$  smaller than the resolution of the OCRs or FCRs associated with the stream, with  $k$  a positive integer larger than or equal to zero. To achieve the same wrap around, the length of the time stamp fields, `TimeStampLength`, shall be  $k$  bit smaller than the length of the OCR or FCR field, `OCRLength` and `FCRLength`, respectively. Hence for each stream the following conditions shall apply for encoding of time stamps:

- `TimeStampResolution` = (OCRResolution or FCRResolution respectively)/ $2^k$ , with  $k$  a positive integer larger than or equal to zero. ISO/IEC 14496-1 requires `TimeStampResolution` to represent an integer number of cycles per second.
- `TimeStampLength` = `OCRLength` or `FCRLength` respectively –  $k$ .

For SL-packetized streams inheriting their object time base from the PCR PID, the following considerations apply:

- `TimeStampResolution` = 90000 /  $2^k$ , with  $k$  a positive integer larger than or equal to zero.
- `TimeStampLength` = 33– $k$ .

For SL-packetized streams carrying an OCR, the relationship between a value of the STC and the corresponding value of the object time base of a stream is established by associating PTS fields in PES packet headers with the OCR or FCR in SL packet headers and M4Mux Stream packets respectively, as specified in 2.11.3.6 and 2.11.3.7.

For SL-packetized streams inheriting their time base from the PCR, the object time base of such a stream is  $f_{stc}(t) / 300$ .

#### 2.11.3.4 Delivery timing of SL-packetized streams

To carry ISO/IEC 14496 content in a Rec. ITU-T H.222.0 | ISO/IEC 13818-1 stream, ISO/IEC 14496-1 SL-packetized streams are used. In each SL-packetized stream carried in a PES packet without the use of M4Mux, the `objectClockReference` field shall be encoded as follows:

- 1) An `objectClockReference` (OCR) field shall be present in the first SL packet header of a SL-packetized stream.
- 2) The SL-packetized stream shall be constructed such that the time interval between the bytes containing the last bit of successive OCR fields shall be less than or equal to 0.7 s. Thus:

$$|t(i'') - t(i')| \leq 0.7 \text{ s}$$

for all  $i'$  and  $i''$  where  $i'$  and  $i''$  are the indexes of the bytes containing the last bit of consecutive OCR fields in the SL-packetized stream.

If an `objectClockReference` is encoded in an SL packet header, also the `instantBitrate` field shall be coded.

#### 2.11.3.5 Delivery timing of M4Mux streams

Next to SL-packetized streams also the ISO/IEC 14496-1 M4Mux tool may be used to carry ISO/IEC 14496 content in Rec. ITU-T H.222.0 | ISO/IEC 13818-1 streams. The payload of M4Mux packets shall consist of SL packets as specified in ISO/IEC 14496-1. In each M4Mux stream carried in a Rec. ITU-T H.222.0 | ISO/IEC 13818-1 stream the `fmxClockReference` field shall be encoded as follows:

- 1) An `fmxClockReference` (FCR) field shall be present in the first M4Mux packet of a M4Mux stream.
- 2) The M4Mux stream shall be constructed such that the time interval between the bytes containing the last bit of successive FCR fields shall be less than or equal to 0.7 s. Thus:

$$|t(i'') - t(i')| \leq 0.7 \text{ s}$$

for all  $i'$  and  $i''$  where  $i'$  and  $i''$  are the indexes of the bytes containing the last bit of consecutive FCR fields in the M4Mux stream.

- 3) All ISO/IEC 14496 time stamps within the SL-packetized streams carried within a M4Mux stream shall refer to instants of the object time base conveyed by the FCR fields in the M4Mux stream. The SL-packetized streams carried in M4Mux packets need not carry OCR fields. If OCR fields are present, they may be ignored.

#### 2.11.3.6 Carriage of SL-packetized streams in PES packets

A single ISO/IEC 14496-1 SL-packetized stream may be mapped into a single PES stream. One and only one SL packet from an SL-packetized stream shall constitute the payload of one PES packet. PES packets that carry an SL-packetized stream shall be identified by `stream_id = 0xFA` in the PES packet header.

When an OCR field is coded in the SL packet header, a PTS shall be encoded in the header of the PES packet that carries such SL packet header. This PTS shall be encoded with the 33-bit value of the 90-kHz portion of the STC that corresponds to the value of the object time base at the instant in time indicated by the OCR.

The `ES_ID` associated with the SL-packetized stream shall be signalled by an SL descriptor as specified in 2.6.46.

#### 2.11.3.7 Carriage of M4Mux streams in PES packets

PES packets with a payload consisting of M4Mux packets shall be identified by `stream_id = 0xFB` in the PES packet header. An integer number of M4Mux packets shall constitute the payload of one PES packet, i.e., the payload of a PES packet carrying a M4Mux stream shall start with a M4Mux packet header and shall end with the last byte of a M4Mux packet.

If an `fmxClockReference` (FCR) field is encoded in one of the M4Mux packets contained in a PES packet, then a PTS shall be encoded in the header of the PES packet that contains such M4Mux packet. This PTS shall be encoded with the 33-bit value of the 90-kHz portion of the STC that corresponds to the value of the object time base of the M4Mux stream at the instant in time indicated by the FCR. In case multiple M4Mux packets with an encoded FCR field are contained in a PES packet, the PTS shall correspond to the time indicated by the FCR in the first such M4Mux packet encountered in the payload of the PES packet.

The `ES_IDs` associated with each SL-packetized stream conveyed in the M4Mux stream shall be signalled by an FMC descriptor as specified in 2.6.44.

#### 2.11.3.8 Carriage of SL packets and M4Mux packets in sections

For transport of ISO/IEC 14496 content in sections, `ISO_IEC_14496_sections` are defined. Any ISO/IEC 14496 stream may be carried over `ISO_IEC_14496_sections`. A single `ISO_IEC_14496_section` shall contain either an entire SL packet of an SL-packetized stream or an integer number of M4Mux packets each carrying an SL packet of the same ISO/IEC 14496-1 elementary stream.

Table 2-153 shows the syntax of `ISO_IEC_14496_sections` defined to convey ISO/IEC 14496-1 elementary streams, qualified by the `table_id` as either object descriptor stream data, scene description stream data or any other ISO/IEC 14496 stream data. Object descriptor stream data consists of an Object Descriptor Table that comprises a number of object descriptors. The Object Descriptor Table may be transmitted in multiple `ISO_IEC_14496_sections`. Scene description data consists of a Scene Description Table that may comprise a number of BIFS commands. The Scene Description Table may be transmitted in multiple `ISO_IEC_14496_sections`. It is not required that a complete table be received in order to process its payload. However, the payload of sections shall be processed in the correct order, as indicated by the value of the `section_number` field in the `ISO_IEC_14496_section` header bytes. Other ISO/IEC 14496 stream data consists of an ISO/IEC 14496 table. The ISO/IEC 14496 table may be transmitted in multiple `ISO_IEC_14496_sections`.

Table 2-153 – Section syntax for transport of ISO/IEC 14496 stream

Syntax	No. of bits	Mnemonic
ISO_IEC_14496_section() {		
<b>table_id</b>	<b>8</b>	<b>uimsbf</b>
<b>section_syntax_indicator</b>	<b>1</b>	<b>bslbf</b>
<b>private_indicator</b>	<b>1</b>	<b>bslbf</b>
<b>reserved</b>	<b>2</b>	<b>bslbf</b>
<b>ISO_IEC_14496_section_length</b>	<b>12</b>	<b>uimsbf</b>
<b>table_id_extension</b>	<b>16</b>	<b>uimsbf</b>
<b>reserved</b>	<b>2</b>	<b>bslbf</b>
<b>version_number</b>	<b>5</b>	<b>uimsbf</b>
<b>current_next_indicator</b>	<b>1</b>	<b>bslbf</b>
<b>section_number</b>	<b>8</b>	<b>uimsbf</b>
<b>last_section_number</b>	<b>8</b>	<b>uimsbf</b>
if (PMT_has_SL_descriptor(current_PID)) {		
SL_Packet()		
}		
else if (PMT_has_FMC_descriptor(current_PID)) {		
for (i = 1; i < N1; i++)		
M4MuxPacket()		
}		
else {		
for (i = 1; i < N2; i++)		
<b>reserved</b>	<b>8</b>	<b>bslbf</b>
}		
<b>CRC_32</b>	<b>32</b>	<b>rpchof</b>
}		

**table\_id** – This 8-bit field shall be set to 0x04, 0x05, or 0x08, in case of an ISO\_IEC\_14496\_section. A value of 0x04 indicates an ISO\_IEC\_14496\_section that carries an ISO/IEC 14496-1 scene description stream. A value of 0x05 indicates an ISO\_IEC\_14496\_section that carries an ISO/IEC 14496-1 object descriptor stream. A value of 0x08 indicates an ISO\_IEC\_14496\_section that carries other ISO/IEC 14496 streams.

**section\_syntax\_indicator** – This 1-bit field shall be set to '1'.

**private\_indicator** – This 1-bit field shall not be specified by this Specification.

**ISO\_IEC\_14496\_section\_length** – This 12-bit field shall specify the number of remaining bytes in the section immediately following the ISO\_IEC\_14496\_section\_length field up to the end of the ISO\_IEC\_14496\_section. The value of this field shall not exceed 4093 (0xFFD).

**table\_id\_extension** – This 16-bit field shall not be specified by this Specification; its use and value are defined by the user.

**version\_number** – This 5-bit field shall represent the version number of the Object Descriptor Table or Scene Description Table respectively. The version number shall be incremented by 1 modulo 32 with each new version of the table. Version control is at the discretion of the application.

**current\_next\_indicator** – This 1-bit field shall be set to 1.

**section\_number** – This 8-bit field shall represent the number of the ISO\_IEC\_14496\_section. The section\_number field of the first ISO\_IEC\_14496\_section of the Object Descriptor Table or the Scene Description Table shall have a value equal to 0x00. The value of section\_number shall be incremented by 1 with each additional section in the table.

**last\_section\_number** – This 8-bit field shall specify the number of the last section of the Object Descriptor Table or Scene Description Table of which this section is a part.

**PMT\_has\_SL\_descriptor(current\_PID)** – A pseudo function that shall be true if an SL descriptor is contained in the descriptor loop in the Program Map Table for the Rec. ITU-T H.222.0 | ISO/IEC 13818-1 program element that conveys this ISO\_IEC\_14496\_section.

**SL\_Packet()** – A sync layer packet as specified in 10.2.2 of ISO/IEC 14496-1.

**PMT\_has\_FMC\_descriptor(current\_PID)** – A pseudo function that shall be true if an FMC descriptor is contained in the descriptor loop in the Program Map Table for the Rec. ITU-T H.222.0 | ISO/IEC 13818-1 program element that conveys this ISO\_IEC\_14496\_section.

**M4MuxPacket()** – A M4Mux packet as specified in 7.4.2.4 of ISO/IEC 14496-1.

**CRC\_32** – This 32-bit field shall contain the CRC value that gives a zero output of the registers in the decoder defined in Annex A after processing the entire ISO\_IEC\_14496\_section.

**2.11.3.9 T-STD extensions**

**2.11.3.9.1 T-STD Model for 14496 content**

Figure 2-7 shows extensions of the Transport System Target Decoder for delivery of ISO/IEC 14496 program elements encapsulated in Rec. ITU-T H.222.0 | ISO/IEC 13818-1 transport streams.

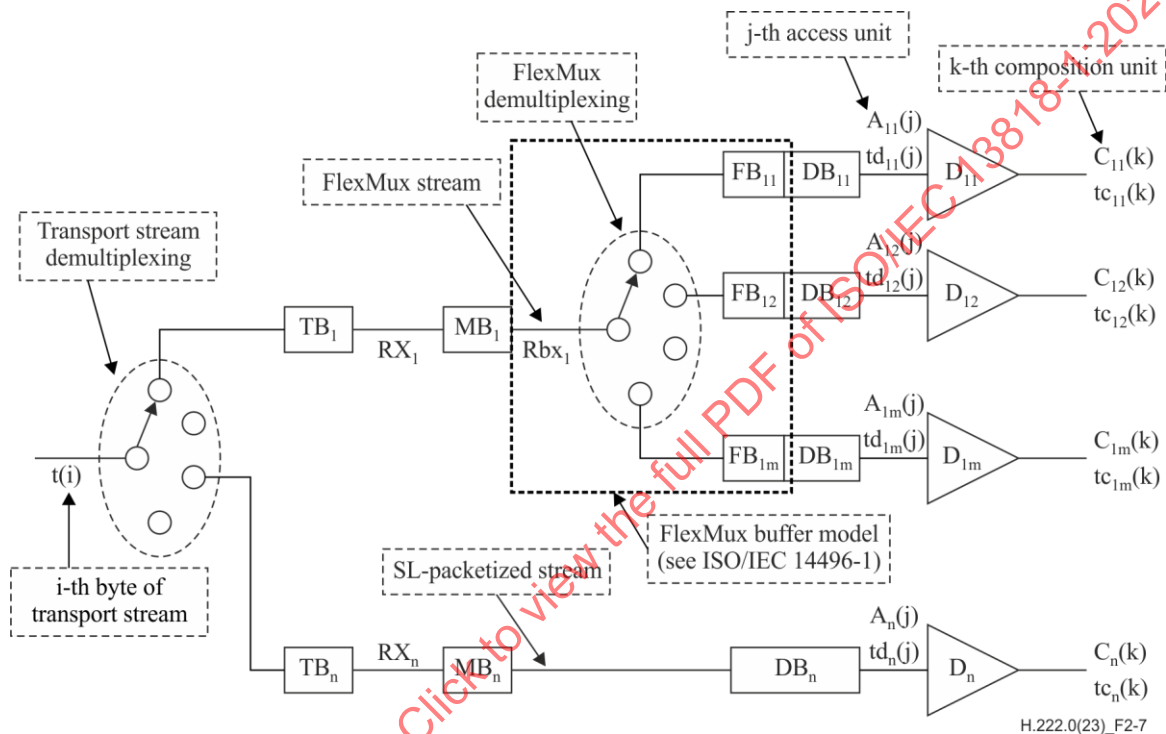

**Figure 2-7 – T-STD model for ISO/IEC 14496 content**

The following notation is used in Figure 2-7 and its description:

$TB_n$  is the transport buffer.

$MB_n$  is the multiplex buffer for M4Mux stream n or for SL-packetized stream n.

$FB_{np}$  is the M4Mux buffer for the elementary stream in M4Mux channel p of M4Mux stream n.

$DB_{np}$  is the decoder buffer for the elementary stream in M4Mux channel p of M4Mux stream n.

$DB_n$  is the decoder buffer for elementary stream n.

$D_{np}$  is the decoder for the elementary stream in M4Mux channel p of M4Mux stream n.

$D_n$  is the decoder for elementary stream n.

$Rx_n$  is the rate at which data are removed from  $TB_n$ .

$Rbx_n$  is the rate at which data are removed from  $MB_n$ .

$A_{np}(j)$  is the jth access unit in elementary stream in M4Mux channel p of M4Mux stream n.  $A_{np}(j)$  is indexed in decoding order.

$A_n(j)$  is the jth access unit in elementary stream n.  $A_n(j)$  is indexed in decoding order.

$Td_{np}(j)$  is the decoding time, measured in seconds, in the system target decoder of the jth access unit in elementary stream in M4Mux channel p of M4Mux stream n.

- $T_{d_n(j)}$  is the decoding time, measured in seconds, in the system target decoder of the  $j$ th access unit in elementary stream  $n$ .
- $C_{np}(k)$  is the  $k$ th composition unit in elementary stream in M4Mux channel  $p$  of M4Mux stream  $n$ .  $C_{np}(k)$  results from decoding  $A_{np}(j)$ .  $C_{np}(k)$  is indexed in composition order.
- $C_n(k)$  is the  $k$ th composition unit in elementary stream  $n$ .  $C_n(k)$  results from decoding  $A_n(j)$ .  $C_n(k)$  is indexed in composition order.
- $tc_{np}(k)$  is the composition time, measured in seconds, in the system target decoder of the  $k$ th composition unit in elementary stream in M4Mux channel  $p$  of M4Mux stream  $n$ .
- $tc_n(k)$  is the composition time, measured in seconds, in the system target decoder of the  $k$ th composition unit in elementary stream  $n$ .
- $t(i)$  indicates the time in seconds at which the  $i$ th byte of the transport stream enters the system target decoder.

### 2.11.3.9.2 Processing of M4Mux streams

Complete transport stream packets containing data from M4Mux stream  $n$  are passed to the transport buffer for M4Mux stream  $n$ ,  $TB_n$ . The size of  $TB_n$  is fixed at 512 bytes. All bytes that enter  $TB_n$  are removed from  $TB_n$  at a rate  $R_{x_n}$ , specified by the `TB_leak_rate` field in the MultiplexBuffer descriptor associated with M4Mux stream  $n$ . When there is no data in buffer  $TB_n$ , rate  $R_{x_n}$  is equal to zero. Duplicate transport stream packets are not delivered to  $MB_n$ .

In case of carriage in PES packets, the PES packet header and payload data bytes are delivered to buffer  $MB_n$ ; all other bytes leaving  $TB_n$  do not enter  $MB_n$ , and may be used to control the system. In case of carriage in ISO\_IEC\_14496\_sections, the section header, payload and CRC-32 data bytes are delivered to buffer  $MB_n$ ; all other bytes do not enter  $MB_n$  and may be used to control the system. In either case, the size of  $MB_n$  shall be specified by the `MB_buffer_size` field in the MultiplexBuffer descriptor.

The M4Mux Stream packet bytes in buffer  $MB_n$  are all delivered to their associated M4Mux buffer at the rate specified by the field `fmxRate` encoded in the M4Mux stream and in compliance with the M4Mux buffer model defined in 11.2.9 of ISO/IEC 14496-1. Only M4Mux packet payload data bytes in M4Mux channel  $p$  of M4Mux stream  $n$  enter buffer  $FB_{np}$ . M4Mux packet header bytes in M4Mux channel  $p$  of M4Mux stream  $n$  are discarded and may be used to control the system. The rate specified by the `fmxRate` field shall be applicable for all M4Mux packets in the stream immediately following the M4Mux Clock Reference channel packet up to the next encountered M4Mux Clock Reference channel packet. When there is no M4Mux stream data present in  $MB_n$ , no data is removed from  $MB_n$ . Bytes from the PES packet header or from the ISO\_IEC\_14496\_section header that immediately precede a M4Mux header are instantaneously removed and discarded and may be used to control the system. Bytes from the ISO\_IEC\_14496\_section CRC-32 fields that immediately follow the last M4Mux Stream packet in the section payload are removed instantaneously and discarded and may be used to verify the integrity of the data. Bytes from the M4Mux Clock Reference channel are instantaneously removed and discarded and may be used to lock the ISO/IEC 14496 object time base to the STC. When there is no PES packet or section payload data bytes, respectively present in  $MB_n$ , no data is removed from  $MB_n$ . All data that enters  $MB_n$  leaves it. All PES packet payload bytes of stream  $n$  enter the M4Mux demultiplexer instantaneously upon leaving  $MB_n$ .

### 2.11.3.9.3 Definition of M4Mux Buffer, $FB_{np}$

For each channel  $p$  of a M4Mux stream  $n$ , the size of M4Mux buffer  $FB_{np}$  is defined using the `M4MuxBufferSize` descriptor. M4Mux packet payload bytes are transferred from buffer  $FB_{np}$  to decoder buffer  $DB_{np}$  in compliance with the M4Mux buffer model defined in 11.2.9 of ISO/IEC 14496-1. Only SL packet payload bytes in M4Mux channel  $p$  of M4Mux stream  $n$  enter buffer  $DB_{np}$ . The SL packet header bytes in M4Mux channel  $p$  of M4Mux stream  $n$  are discarded and may be used to control the system.

### 2.11.3.9.4 Processing of SL-packetized streams

Complete transport stream packets containing data from SL-packetized stream  $n$  are passed to the transport buffer for SL-packetized stream  $n$ ,  $TB_n$ . All bytes that enter  $TB_n$  are removed at a rate  $R_{x_n}$ , specified by the `TB_leak_rate` field in the MultiplexBuffer descriptor. When there is no data in buffer  $TB_n$ , rate  $R_{x_n}$  is equal to zero. Duplicate transport stream packets are not delivered to  $MB_n$ .

In case of carriage in PES packets, the PES packet header and payload data bytes are delivered to buffer  $MB_n$ ; all other bytes leaving  $TB_n$  do not enter  $MB_n$ , and may be used to control the system. In case of carriage in ISO\_IEC\_14496\_sections, the section header, payload and CRC-32 data bytes are delivered to buffer  $MB_n$ ; all other bytes do not enter  $MB_n$  and may be used to control the system. In either case the size of  $MB_n$  is specified by the `MB_buffer_size` field in the MultiplexBuffer descriptor.

The SL-packetized stream bytes in buffer  $MB_n$  are all delivered to the decoder buffer  $DB_n$  at the rate specified by the field `instantBitRate` encoded in the SL-packetized stream and in compliance with the System Decoder Model defined in 7.4 of

ISO/IEC 14496-1. The rate specified by the instantBitRate field shall be applicable for all data bytes in the SL-packetized stream immediately following the instantBitRate field in the SL packet header up to the next encountered instantBitRate field. If there are no SL-packetized stream bytes in MB<sub>n</sub>, no bytes are removed from MB<sub>n</sub>. Bytes from the PES packet header or from the ISO\_IEC\_14496\_section header that immediately precede a SL packet header are instantaneously removed and discarded and may be used to control the system. Bytes from the ISO\_IEC\_14496\_section CRC-32 fields that immediately follow the last SL packet payload byte in the section are removed instantaneously and discarded and may be used to verify the integrity of the data. When there are no PES packet or section payload data bytes, respectively present in MB<sub>n</sub>, no data is removed from MB<sub>n</sub>. All data that enters MB<sub>n</sub> leaves it. All PES packet payload bytes of stream n enter buffer DB<sub>n</sub> instantaneously upon leaving MB<sub>n</sub>, with the exception of the SL packet headers. Bytes from the SL packet headers do not enter DB<sub>n</sub> and may be used to control the system. The size of decoder buffer DB<sub>n</sub> is given by the bufferSizeDB of the DecoderConfigDescriptor defined in ISO/IEC 14496-1.

**2.11.3.9.5 Buffer management**

Transport streams shall be constructed so that conditions defined in this subclause are satisfied.

TB<sub>n</sub> shall not overflow and shall be empty at least once every second. MB<sub>n</sub> shall not overflow. FB<sub>np</sub> shall not overflow. DB<sub>np</sub> and DB<sub>n</sub> shall neither underflow nor overflow. Underflow of DB<sub>np</sub> occurs when one or more bytes of an access unit are not present in DB<sub>np</sub> at the decoding time associated with this access unit. Underflow of DB<sub>n</sub> occurs when one or more bytes of an access unit are not present in DB<sub>n</sub> at the decoding time associated with this access unit.

**2.11.3.10 Carriage within a transport stream**

**2.11.3.10.1 Overview**

A transport stream may contain one or more programs, each described by a Program Map Table. ISO/IEC 14496 content can be conveyed in addition to the already defined stream types for such a program. Elements of the ISO/IEC 14496 content may be conveyed in one or more Rec. ITU-T H.222.0 | ISO/IEC 13818-1 program elements referenced by a unique PID value within a transport stream. As a special case, it is possible that a program within a transport stream consists only of ISO/IEC 14496 program elements. ISO/IEC 14496 content associated with a program and carried in the transport stream shall be referenced in the Program Map Table of that program. An initial object descriptor shall be used to define an ISO/IEC 14496-1 scene; the use of this descriptor is specified in 2.11.3.10.2.

Carriage of ISO/IEC 14496 content in a PID is signalled by a stream\_type value of 0x12 or 0x13 in the Program Map Table in association with that PID value. A value of 0x12 indicates carriage in PES packets. The stream\_id field in the PES packet header signals whether the PES packet contains a single SL packet or a number of M4Mux packets. A stream\_type value of 0x13 in the Program Map Table indicates that the program element carries an object descriptor stream or a BIFS-Command stream contained in sections. In this case the table\_id in the section header indicates whether an object descriptor stream is carried in the sections or a BIFS-Command stream. See also Table 2-154. The section contains either a single SL packet or a number of M4Mux packets, as indicated by the presence of an SL descriptor or a FMC descriptor respectively in the descriptor loop of the Program Map Table for the Rec. ITU-T H.222.0 | ISO/IEC 13818-1 program element that carries the sections. When ISO/IEC 14496 content is carried, the SL descriptor and the FMC descriptor shall specify the ES\_ID for each encapsulated ISO/IEC 14496 stream. When the assignment of ES\_ID values changes, the Program Map Table shall be updated and the version\_number of the PMT shall be incremented by 1 modulo 32. An example of a content access procedure for ISO/IEC 14496 program components within a transport stream is given in Annex R.

**Table 2-154 – ISO/IEC defined options for carriage of an ISO/IEC 14496 scene and associated streams in Rec. ITU-T H.222.0 | ISO/IEC 13818-1**

ISO/IEC 14496-1 object descriptor streams	Encapsulation in SL packets	Carriage in PES packets	Stream_type = 0x12	Stream_id = '1111 1010'
		Carriage in ISO_IEC_14496_sections	Stream_type = 0x13	Table_id = 0x05
	Encapsulation in SL packets followed by Multiplex into M4Mux packets	Carriage in PES packets	Stream_type = 0x12	Stream_id = '1111 1011'
		Carriage in ISO_IEC_14496_sections	Stream_type = 0x13	Table_id = 0x05
ISO/IEC 14496-1 scene description streams	Encapsulation in SL packets	Carriage in PES packets	Stream_type = 0x12	Stream_id = '1111 1010'
		Carriage in ISO_IEC_14496_sections	Stream_type = 0x13	Table_id = 0x04
	Encapsulation in SL packets followed by Multiplex into M4Mux packets	Carriage in PES packets	Stream_type = 0x12	Stream_id = '1111 1011'
		Carriage in ISO_IEC_14496_sections	Stream_type = 0x13	Table_id = 0x04

**Table 2-154 – ISO/IEC defined options for carriage of an ISO/IEC 14496 scene and associated streams in Rec. ITU-T H.222.0 | ISO/IEC 13818-1**

All other ISO/IEC 14496 streams	Encapsulation in SL packets	Carriage in PES packets	Stream_type = 0x12	Stream_id = '1111 1010'
	Encapsulation in SL packets followed by Multiplex into M4Mux packets	Carriage in PES packets	Stream_type = 0x12	Stream_id = '1111 1011'

**2.11.3.10.2 Initial Object Descriptor**

In case of carriage of an ISO/IEC 14496-1 scene, the ISO/IEC 14496-1 initial object descriptor serves as the initial access point to all associated streams. The initial object descriptor shall be conveyed in the IOD descriptor located in the descriptor loop immediately following the program\_info\_length field in the Program Map Table of the program to which the scene is associated. It contains ES\_Descriptors identifying the scene description and object descriptor streams that form part of this program. It may also contain ES\_Descriptors identifying one or more associated IPMP or OCI streams. Identification of streams is done by means of ES\_IDs as specified in clauses 7.2.1 and 7.2.6.5 of ISO/IEC 14496-1.

**2.11.3.11 P-STD Model for 14496 content**

Figure 2-8 shows the STD model when ISO/IEC 14496 systems data are carried in a program stream.

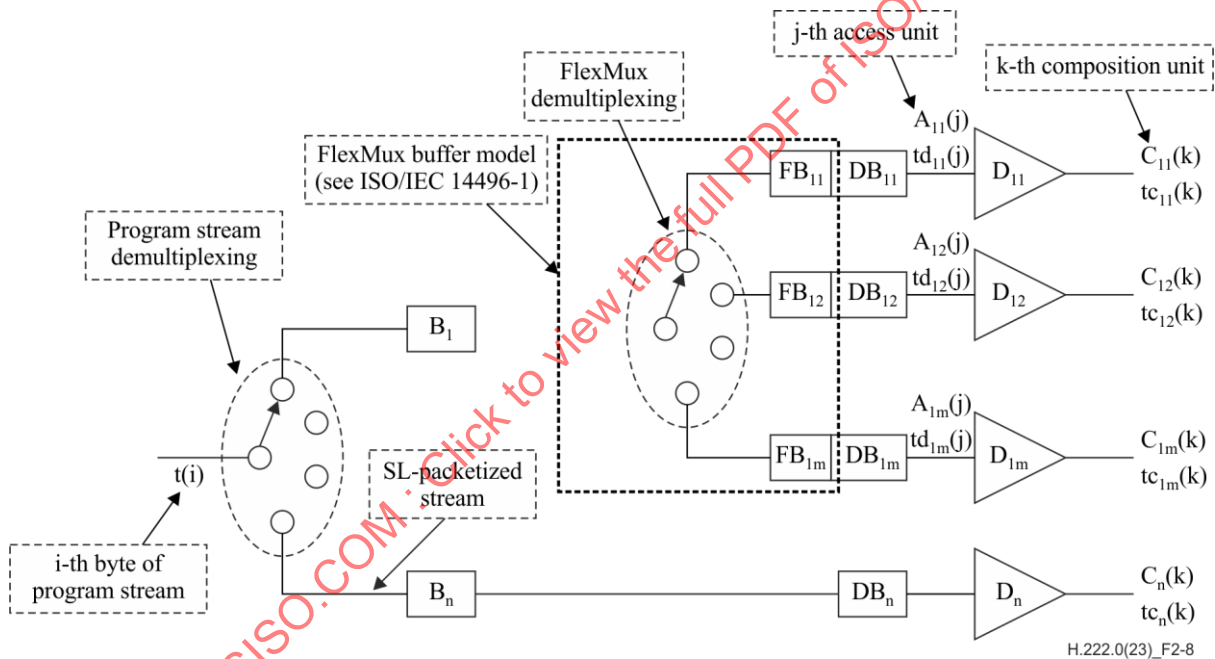

**Figure 2-8 – P-STD model for ISO/IEC 14496 Systems stream**

The following notation is used in Figure 2-8 and its description:

- $B_n$  is the input buffer for M4Mux stream n or for SL-packetized stream n.
- $FB_{np}$  is the M4Mux buffer for the elementary stream in M4Mux channel p of M4Mux stream n.
- $DB_{np}$  is the decoder buffer for the elementary stream in M4Mux channel p of M4Mux stream n.
- $DB_n$  is the decoder buffer for elementary stream n.
- $D_{np}$  is the decoder for elementary stream in M4Mux channel p of M4Mux stream n.
- $D_n$  is the decoder for elementary stream n.
- $A_{np}(j)$  is the jth access unit in elementary stream in M4Mux channel p of M4Mux stream n.  $A_{np}(j)$  is indexed in decoding order.
- $A_n(j)$  is the jth access unit in elementary stream n.  $A_n(j)$  is indexed in decoding order.
- $Td_{np}(j)$  is the decoding time, measured in seconds, in the system target decoder of the jth access unit in elementary stream in M4Mux channel p of M4Mux stream n.

- $T_{d_n(j)}$  is the decoding time, measured in seconds, in the system target decoder of the  $j$ th access unit in elementary stream  $n$ .
- $C_{np(k)}$  is the  $k$ th composition unit in elementary stream in M4Mux channel  $p$  of M4Mux stream  $n$ .  $C_{np(k)}$  results from decoding  $A_{np(j)}$ .  $C_{np(k)}$  is indexed in composition order.
- $C_n(k)$  is the  $k$ th composition unit in elementary stream  $n$ .  $C_n(k)$  results from decoding  $A_n(j)$ .  $C_n(k)$  is indexed in composition order.
- $tc_{np(k)}$  is the composition time, measured in seconds, in the system target decoder of the  $k$ th composition unit in elementary stream in M4Mux channel  $p$  of M4Mux stream  $n$ .
- $tc_n(k)$  is the composition time, measured in seconds, in the system target decoder of the  $k$ th composition unit in elementary stream  $n$ .
- $t(i)$  indicates the time in seconds at which the  $i$ th byte of the program stream enters the system target decoder.

### 2.11.3.11.1 Processing of M4Mux streams

At the input of the STD each byte in the payload of PES packets carrying a M4Mux stream  $n$  is transferred instantaneously to buffer  $B_n$ . The  $i$ -th byte enters  $B_n$  at time  $t(i)$ . PES packet header bytes do not enter buffer  $B_n$  and may be used to control the system. The size of  $B_n$  is specified by the P-STD\_buffer\_size field in the header of the PES packet that carries stream  $n$ .

The M4Mux stream packet bytes in buffer  $B_n$  are all delivered to their associated M4Mux buffer at the rate specified by the field `fmRate` encoded in the M4Mux stream and in compliance with the M4Mux buffer model defined in 7.4.2.9 of ISO/IEC 14496-1. Only M4Mux packet payload data bytes in M4Mux channel  $p$  of M4Mux stream  $n$  enter buffer  $FB_{np}$ . M4Mux packet header bytes in M4Mux channel  $p$  of M4Mux stream  $n$  are discarded and may be used to control the system. The rate specified by the `fmRate` field shall be applicable for all M4Mux packets in the stream up to the next encountered M4Mux Clock Reference channel packet. Bytes from the M4Mux Clock Reference channel are instantaneously removed and discarded and may be used to lock the ISO/IEC 14496 object time base to the STC. When there is no PES packet payload data present in  $B_n$ , no data is removed from  $B_n$ . All data that enters  $B_n$  leaves it. All PES packet payload bytes of stream  $n$  enter the M4Mux demultiplexer instantaneously upon leaving  $B_n$ .

### 2.11.3.11.2 Definition of M4Mux Buffer, $FB_{np}$

For each channel  $p$  of a M4Mux stream  $n$ , the size of M4Mux buffer  $FB_{np}$  is defined using the `M4MuxBufferSize` descriptor if a Program Stream Map is present in the program stream. M4Mux packet payload bytes are transferred from buffer  $FB_{np}$  to decoder buffer  $DB_{np}$  in compliance with the M4Mux buffer model defined in 7.4.2.9 of ISO/IEC 14496-1. Only SL packet payload bytes in M4Mux channel  $p$  of M4Mux stream  $n$  enter buffer  $DB_{np}$ . The SL packet header bytes in M4Mux channel  $p$  of M4Mux stream  $n$  are discarded and may be used to control the system.

### 2.11.3.11.3 Processing of SL-packetized streams

At the input of the STD each byte in the payload of PES packets carrying an SL-packetized stream  $n$  is transferred instantaneously to buffer  $B_n$ . The  $i$ -th byte enters  $B_n$  at time  $t(i)$ . PES packet header bytes do not enter buffer  $B_n$  and may be used to control the system. The size of  $B_n$  is specified by the P-STD\_buffer\_size field in the header of the PES packet that carries stream  $n$ . The SL-packetized stream bytes in buffer  $B_n$  are delivered to the decoder buffer  $DB_n$  at the rate specified by the field `instantBitRate` encoded in the SL-packetized stream and in compliance with the System Decoder Model defined in 7.1.4.1 of ISO/IEC 14496-1. The rate specified by the `instantBitRate` field shall be applicable for all data bytes in the SL-packetized stream up to the next encountered `instantBitRate` field. When there is no PES packet payload data present in  $B_n$ , no data is removed from  $B_n$ . All data that enters  $B_n$  leaves it. All bytes of stream  $n$  enter buffer  $DB_n$  instantaneously upon leaving  $B_n$ , with the exception of the SL packet headers. Bytes from the SL packet headers do not enter  $DB_n$  and may be used to control the system. The size of decoder buffer  $DB_n$  is given by the `bufferSizeDB` of the `DecoderConfigDescriptor` defined in ISO/IEC 14496-1.

### 2.11.3.11.4 Buffer management

Program streams shall be constructed so that  $B_n$  does not overflow.  $FB_{np}$  shall not overflow.  $DB_{np}$  and  $DB_n$  shall neither underflow nor overflow. Underflow of  $DB_{np}$  occurs when one or more bytes of an access unit are not present in  $DB_{np}$  at the decoding time associated with this access unit. Underflow of  $DB_n$  occurs when one or more bytes of an access unit are not present in  $DB_n$  at the decoding time associated with this access unit.

## 2.11.3.12 Carriage within a program stream

### 2.11.3.12.1 Overview

A program stream contains only one program. ISO/IEC 14496 data can be conveyed in addition to the already defined stream types for such a program. As a special case, it is also possible that a program stream carries only ISO/IEC 14496

data. If a Program Stream Map is present, ISO/IEC 14496 content carried in the program stream shall be referenced as follows. Carriage of ISO/IEC 14496-1 scenes and associated ISO/IEC 14496 streams in SL and M4Mux packets is indicated by the appropriate stream\_id and by an initial object descriptor; the use of this descriptor is specified in 2.11.3.12.2. For each carried ISO/IEC 14496 stream the SL descriptor and the FMC descriptor shall specify the ES\_ID. When the assignment of ES\_ID values changes, the Program Stream Map, if present, shall be updated and the program\_stream\_map\_version shall be incremented by 1 modulo 32. Note that in a Program Stream the ISO/IEC 14496 content may also be referenced by private means.

For an example of a content access procedure for ISO/IEC 14496 program components within a program stream, see Annex R.

### 2.11.3.12.2 Initial object descriptor

In case of carriage of an ISO/IEC 14496-1 scene, the ISO/IEC 14496 initial object descriptor serves as the initial access point to all associated streams. If a Program Stream Map is present in the program stream, the initial object descriptor shall be conveyed in the IOD descriptor that is located in the descriptor loop immediately following the program\_stream\_info\_length field. It contains ES\_Descriptors identifying the scene description and object descriptor streams of the scene that form part of this program. It may also contain ES\_Descriptors identifying one or more associated IPMP or OCI streams. Identification of streams is done by means of ES\_IDs as specified in clause 7.2.1 and 7.2.6.5 of ISO/IEC 14496-1. In a program stream, the initial object descriptor may also be conveyed by private means.

## 2.12 Carriage of metadata

### 2.12.1 Introduction

A Rec. ITU-T H.222.0 | ISO/IEC 13818-1 stream can carry metadata. The format of the metadata may be defined by ISO or by any other authority. This subclause defines how to carry the metadata; transport mechanisms are defined as well as metadata related-signalling, the applied metadata timing model and extensions of the STD model for decoding of metadata.

A metadata service is defined to be a coherent set of metadata of the same format delivered to a receiver for a specific purpose. Metadata services are contained in metadata streams; each metadata stream carries one or more metadata services. This Specification assumes the notion of metadata Access Units within a metadata service. The definition of a Metadata Access Unit is metadata format specific, but each metadata service is assumed to represent a concatenation (or a collection) of metadata Access Units.

When transporting a metadata service over a Rec. ITU-T H.222.0 | ISO/IEC 13818-1 stream, a unique metadata service id is assigned to each such service. A metadata service id references uniquely a metadata service among all the metadata services available on the same transport or program stream, and *not* unique *solely* within a metadata stream. The metadata service identifier is used to retrieve the metadata service and all the information needed to decode it.

Decoding of metadata may require the availability of decoder configuration data. If a metadata service carried in a Rec. ITU-T H.222.0 | ISO/IEC 13818-1 stream requires decoder configuration data for decoding, then this metadata decoder configuration data shall be carried within the same program of the same Rec. ITU-T H.222.0 | ISO/IEC 13818-1 stream.

Clause 2.12.2 discusses metadata timing, while 2.12.3 provides an overview of tools that are defined for transport of metadata over a Rec. ITU-T H.222.0 | ISO/IEC 13818-1 stream. The use of available transport tools is specified in 2.12.4 up to 2.12.8, and 2.12.9 specifies metadata related signalling. Finally, the STD model for metadata decoding is specified in 2.12.10.

Since many forms of metadata may be carried, it is essential to signal both the precise format and encoding of the metadata, and the semantic meaning the metadata conveys. The former is signalled by the metadata format, while the latter is signalled by the metadata application format. In other words, the metadata format conveys how the metadata shall be decoded, while the metadata application format conveys how to use the metadata, essentially which application uses the metadata. This division is important since it separates the encoding or representation of the metadata from its meaning, thereby allowing an application to be agnostic of the means by which its metadata is conveyed.

### 2.12.2 Metadata time-line model

Metadata may refer to time codes associated with the content, for example to indicate the beginning of a content segment. Each time indication made in the metadata refers to a certain metadata content time line specific to the actual metadata format and/or metadata application format. For example, one metadata (application) format may use UTC, while another metadata application format may use SMPTE time codes. To allow for transport of the content at any time over any media, the metadata content time line is expected but not required to be transport agnostic.

When transporting content and the associated metadata over Rec. ITU-T H.222.0 | ISO/IEC 13818-1 streams, accurate time references from the metadata to the content are to be maintained. The same is needed if the metadata is delivered over other means. To achieve this, the time line model of Figure 2-9 is assumed in this Specification.

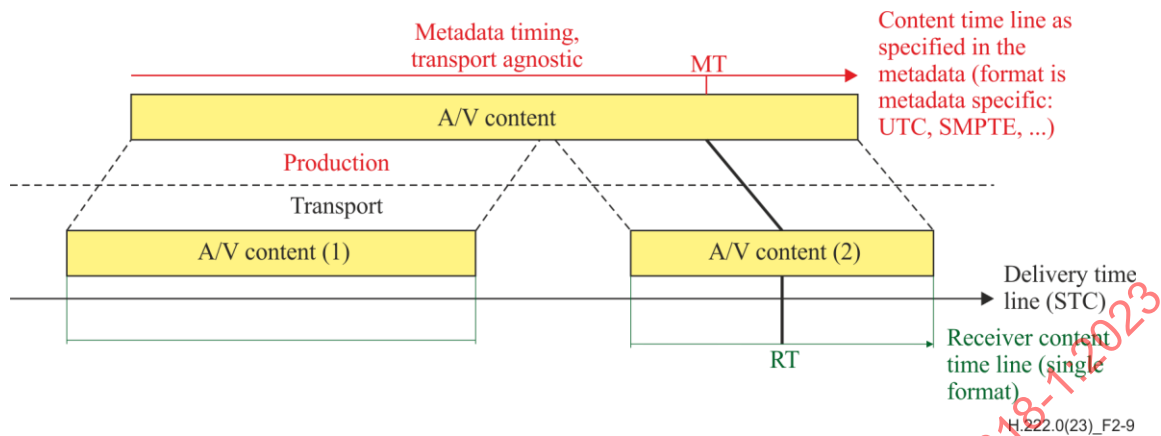

Figure 2-9 – Timing model for delivery of content and metadata

Metadata is associated with the audiovisual content, usually in a transport agnostic way, at production or any other stage prior to transport. Where needed, time information is embedded in the metadata to indicate for example specific segments within the content, using the metadata content time line used in the metadata. For example, UTC or SMPTE time codes may be used. The time line format is independent of any time code that may or may not be embedded in the audiovisual stream itself. For example, the metadata time line may utilize UTC, while SMPTE time codes are embedded in the video stream.

The following requirements shall be met for each metadata stream:

- no time discontinuities shall occur in the metadata content time line;
- the metadata content time line shall be locked to the sampling clock of the content;
- each time reference in the metadata stream refers to the same metadata content time line.

At transport, a transport-specific timing is associated with the content; this is the delivery time line. In the case of transport over a Rec. ITU-T H.222.0 | ISO/IEC 13818-1 stream, the delivery time line is provided by the System Time Clock, the STC. The content may be delivered as a contiguous piece of information, but it is also possible to interrupt the delivery of the content, for example in the case of news-flash interruptions of a program; in such and other cases time line discontinuities may occur.

When time references are used in the metadata, in the System Target Decoder (STD) these time references are to be associated unambiguously with time values in the received content. To achieve this, a receiver content time line is required. The STC can be used as the receiver content time line, but due to STC discontinuities that may occur, the STC does not necessarily offer an unambiguous time association. Therefore the NPT (Normal Play Time) concept from ISO/IEC 13818-6 DSM-CC is also available for use as the receiver content time line. In any playback mode, such as normal, reverse, slow motion, fast forward, fast backward and still picture, the NPT provides an unambiguous time association, independent of STC discontinuities, and independent of insertions of other content. Note that a new NPT\_reference\_descriptor needs to be transmitted when the STC rolls over.

To maintain the accurate time references from metadata to the content, information is needed how to map a metadata time, MT, defined on the metadata content time line to the corresponding receiver time, RT, of the receiver content time line. This is achieved by providing the offset in time (in 90-kHz units) between the metadata content time line and the receiver content time line. The offset is provided in the content labelling descriptor. The offset conveys the value of the metadata time base at the instant in time at which the receiver content time base reaches a specified value. See also Figure 2-9.

The timing in metadata systems may refer to a specific picture or audio frame, for example using SMPTE time codes. The offset in time between the metadata content time line and the receiver content time line is expressed in units of 90 kHz, and consequently the metadata time reference will translate into a 90-kHz value in receivers. To accommodate for inaccuracies, receivers shall assume that when reference is made to a picture or audio frame the closest match shall be used. For example, the translated 90-kHz metadata time reference shall be matched with the picture or frame whose PTS value is closest to the translated value.

When using NPT, during playback in any mode at any point in time the offset remains constant between the metadata time base and the NPT time base. As long as neither STC discontinuities nor insertions with other content occur, the same is true for the offset in time between the metadata time base and the STC time base, but only in normal playback mode. For privately defined time lines the offset is also required to be constant, but possibly within constraints not defined in this Specification.

When synchronous transport of metadata is applied in PES packets or by using the synchronized DSM-CC download protocol, PTSs are assigned to the metadata. Such PTS may for example indicate the point in time at which the metadata becomes valid. This implies *a priori* knowledge of how to associate the metadata to the delivery timing. However, synchronously transported metadata may also contain time references, which are to be mapped from the metadata content time line to the receiver content time line using the specified offset between both time lines. See also Figure 2-10.

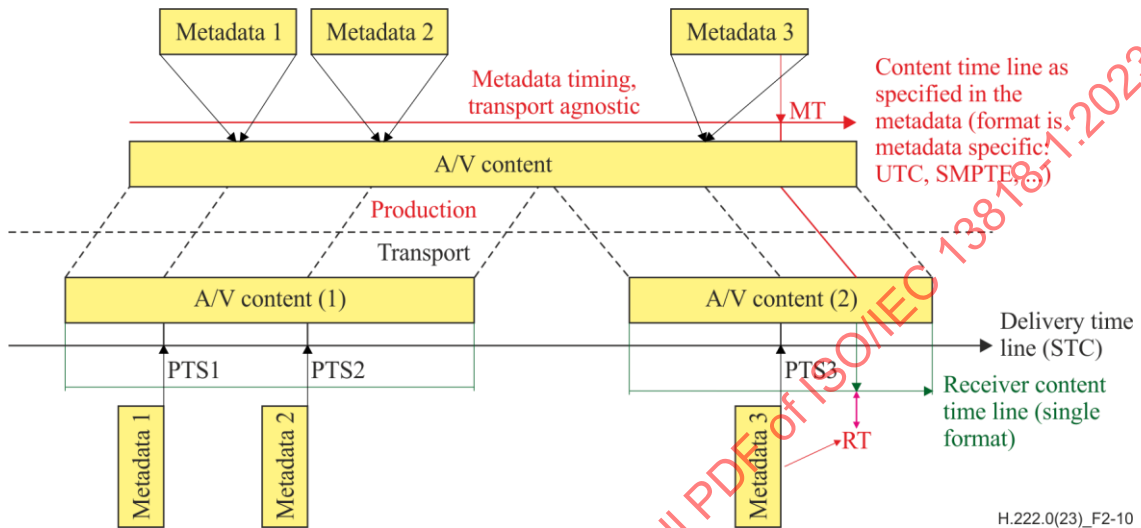

Figure 2-10 – Delivery of metadata in PES packets

### 2.12.3 Options for transport of metadata

To acknowledge the very diverse characteristics of metadata, a variety of tools is defined to transport the metadata over a Rec. ITU-T H.222.0 | ISO/IEC 13818-1 stream.

This Specification defines two tools for synchronous delivery of the metadata:

- carriage in PES packets;
- use of DSM-CC synchronized download protocol.

In addition, this Specification defines three tools for asynchronous delivery of metadata:

- carriage in metadata sections;
- use of DSM-CC data carousels;
- use of DSM-CC object carousels.

Note that some of the asynchronous transport options support carousels and file structures. The choice of transport tool depends on the requirements that apply to the delivery of the metadata, and the requirements of the tools, as described in the following subclauses.

Metadata may also be carried by private means such as PES packets with stream id value 0xBD or 0xBF (private\_stream\_id\_1 or private\_stream\_id\_2) or private sections. This Specification does not specify how to use private means for carriage of metadata, but allows for signalling of such metadata using the descriptors defined in 2.6.56 up to 2.6.63.

The basic referencing of metadata services is the same for all tools, using the metadata service id. However, there are differences per tool. When PES packets, metadata sections, or synchronized DSM-CC download sections are used, data from each metadata service is explicitly signalled within a metadata stream, using the metadata\_service\_id field. However, when using DSM-CC carousels, this signalling is left at the discretion of metadata applications. Note that this Specification allows for carriage of a metadata service in a DSM-CC carousel, but does not constrain how many metadata services can be carried in one DSM-CC carousel.

Metadata decoder configuration data is signalled explicitly when carried in a metadata descriptor, in PES packets with stream\_type 0x15 and stream\_id 0xFC, in metadata sections or in synchronized DSM-CC download sections. When

metadata decoder configuration data is carried in a DSM-CC carousel, the signalling of such data is required, but not defined by this Specification; instead, such signalling is left at the discretion of applications.

## 2.12.4 Use of PES packets to transport metadata

### 2.12.4.1 General

PES packets provide a mechanism for synchronous transport of metadata. By means of the PTS in the PES packet header the metadata access units are associated with a certain instant of the STC, without the need for time references in the metadata. This implies *a priori* knowledge of how to associate the metadata to the delivery timing. Specific *stream\_id* and *stream\_type* values are assigned to signal PES packets carrying metadata; see 2.12.9.

When using PES packets with a *stream\_type* of 0x15 and a *stream\_id* of 0xFC to transport the metadata, a Metadata Access Unit Wrapper shall be used as the tool to align PES packets and the metadata Access Units, using *metadata\_AU\_cells*. This allows random access indication, whose meaning depends on the format of the metadata, and a cell sequence counter to identify loss of *metadata\_AU\_cells*. Each metadata Access Unit is carried and, if appropriate, fragmented in one or more *metadata\_AU\_cells*. In each PES packet that carries metadata, the first *PES\_packet\_data\_byte* shall be the first byte of a *Metadata\_AU\_cell*. For each metadata Access Unit contained in the same PES packet, the PTS in the PES header applies. The PTS signals the time at which the metadata Access Units are decoded instantaneously and removed from buffer  $B_n$  in the STD. Note that the relationship between a decoded metadata Access Unit and audiovisual content is beyond the scope of this Specification.

A PES packet may contain a single *metadata\_AU\_cell*. This is useful if a metadata Access Unit does not fit into a single PES packet, in which case the fragmentation of the metadata Access Unit is handled by the *metadata\_AU\_cell*.

When metadata is carried by PES packets in a program stream, and if a Program Stream Map is applied in that program stream, then the Program Stream Map shall specify which PES packets contain the associated metadata.

### 2.12.4.2 Metadata Access Unit Wrapper

The metadata Access Unit Wrapper (see Table 2-155) shall be used when carrying metadata Access Units in PES packets with a *stream\_type* of 0x15 and a *stream\_id* value of 0xFC or in synchronized DSM-CC download sections of *stream\_type* 0x19. The wrapper defines a structure consisting of a concatenated number of *Metadata\_AU\_cells* (see Table 2-156). By coding the size of the contained metadata in each *metadata\_AU\_cell*, metadata agnostic parsing is possible in receivers: the parser can retrieve the metadata and provide it to a metadata decoder without *a priori* knowledge on any detail of the metadata. The *Metadata\_AU\_cell* shall be aligned with the transport; that is the first byte of the payload of the PES packet or synchronized DSM-CC download section shall be the first byte of a *Metadata\_AU\_cell*.

If a metadata Access Unit does not fit entirely into a *metadata\_AU\_cell*, then the metadata Access Unit shall be fragmented into multiple *metadata\_AU\_cells*, where the *fragmentation\_indication* in each such *metadata\_AU\_cell* signals that the *metadata\_AU\_cell* contains a fragment.

To each *Metadata\_AU\_cell* that is contained in the same PES packet or synchronized download section, the PTS as coded in the header of the PES packet or synchronized download section, respectively, applies.

Table 2-155 – Metadata Access Unit Wrapper

Syntax	No. of bits	Mnemonic
<pre>Metadata_AU_wrapper () {     for (i = 0; i &lt; N; i++){         Metadata_AU_cell ()     } }</pre>		

Table 2-156 – Metadata AU cell

Syntax	No. of bits	Mnemonic
<pre>Metadata_AU_cell () {     metadata_service_id     sequence_number     cell_fragment_indication     decoder_config_flag     random_access_indicator     reserved     AU_cell_data_length     for (i = 0; I &lt; AU_cell_data_length; i++){         AU_cell_data_byte     } }</pre>	<p>8</p> <p>8</p> <p>2</p> <p>1</p> <p>1</p> <p>4</p> <p>16</p> <p>8</p>	<p>uimsbf</p> <p>uimsbf</p> <p>bslbf</p> <p>bslbf</p> <p>bslbf</p> <p>bslbf</p> <p>uimsbf</p> <p>bslbf</p>

**metadata\_service\_id:** This 8-bit field identifies the metadata service associated with the metadata Access Unit carried in this metadata AU cell.

**sequence\_number:** This 8-bit field specifies the sequence number of the metadata\_AU\_cell. This number increments by one for each successive metadata\_AU\_cell constituting the metadata\_AU\_wrapper, independent of the coded value of the metadata\_service\_id.

**cell\_fragment\_indication:** This 2-bit field conveys information on the metadata Access Unit carried in this metadata\_AU\_cell, corresponding to Table 2-157.

Table 2-157 – Cell fragment indication

Value	Description
'11'	A single cell carrying a complete metadata Access Unit.
'10'	The first cell from a series of cells with data from one metadata Access Unit.
'01'	The last cell from a series of cells with data from one metadata Access Unit.
'00'	A cell from a series of cells with data from one metadata Access Unit, but neither the first nor the last one.

**random\_access\_indicator:** This 1-bit field, when coded with the value '1', indicates that the metadata carried in this metadata\_AU\_cell represents an entry point to the metadata service where decoding is possible without information from previous metadata\_AU\_cells. The meaning of a random access point is defined by the format of the metadata.

**decoder\_config\_flag:** This 1-bit field signals the presence of decoder configuration information in the carried metadata Access Unit. Note that this does not preclude the presence of metadata in the Access Unit next to decoder configuration data.

**AU\_cell\_data\_length:** This 16-bit field specifies the number of AU\_cell\_data\_bytes immediately following.

**AU\_cell\_data\_byte:** This 8-bit field contains contiguous bytes from a metadata Access Unit.

### 2.12.5 Use of the DSM-CC synchronized download protocol to transport metadata

For synchronized transport, in addition to PES packets, the DSM-CC synchronized download protocol can be used. When using synchronized DSM-CC download sections to transport the metadata, the Metadata Access Unit Wrapper defined in 2.12.4.2 shall be used as the tool to encapsulate metadata Access Units. This allows random access indication, whose meaning depends on the format of the metadata, and a cell sequence counter to identify loss of metadata\_AU\_cells. In each DSM-CC synchronized download section that carries metadata, the first byte of the payload shall be the first byte of a Metadata\_AU\_cell. For each metadata Access Unit contained in the same DSM-CC synchronized download section, the PTS in the section header applies. The PTS signals the time at which the metadata Access Units are decoded

instantaneously and removed from buffer  $B_n$  in the STD. Note that the relationship between a decoded metadata Access Unit and audiovisual content is beyond the scope of this Specification. A specific stream\_type value (as detailed in Table 2-34) is assigned to signal carriage of metadata in DSM-CC synchronized download sections.

**2.12.6 Use of metadata sections to transport metadata**

If asynchronous transport of metadata Access Units without a carousel delivery mechanism is needed, metadata sections can be utilized. The syntax and semantics of metadata sections are defined in this subclause. Each metadata section shall carry either one complete metadata Access Unit or a single part of one metadata Access Unit, as signalled by the section\_fragment\_indication field (see Table 2-158).

For transport in metadata sections, the metadata Access Units are structured in one or more Metadata Tables. Each Metadata Table contains one or more complete metadata Access Units from one or more metadata services. Conceptually, the transport mechanism of Metadata Tables is comparable to the transport mechanism of Program Map Tables and Program Association Tables. Each Metadata Table may be made up of multiple metadata sections. Each Metadata Table may contain metadata from multiple metadata services.

Specific stream\_type and table\_id values are assigned to metadata sections. Metadata decoder configuration data can also be carried in sections, signalled by a metadata description value, as assigned by the metadata decoder configuration descriptor.

**Table 2-158 – Section syntax for transport of metadata**

Syntax	No. of bits	Mnemonic
Metadata_section() {		
table_id	8	uimsbf
section_syntax_indicator	1	bslbf
private_indicator	1	bslbf
random_access_indicator	1	bslbf
decoder_config_flag	1	bslbf
metadata_section_length	12	uimsbf
metadata_service_id	8	uimsbf
reserved	8	bslbf
section_fragment_indication	2	bslbf
version_number	5	uimsbf
current_next_indicator	1	bslbf
section_number	8	uimsbf
last_section_number	8	uimsbf
for (i = 1; i < N; i++){		
metadata_byte	8	bslbf
}		
CRC_32	32	rpchof
}		

**table\_id:** The table\_id is an 8-bit field that shall be set to '0x06' for each metadata section.

**section\_syntax\_indicator:** This 1-bit field shall be set to '1'.

**private\_indicator:** This 1-bit field is not specified by this Specification.

**random\_access\_indicator:** This 1-bit field, when coded with the value '1', indicates that the metadata carried in this metadata section represents an access point to the metadata service where decoding is possible without information from previous metadata sections. The meaning of a random access point is defined by the format of the metadata.

**decoder\_config\_flag:** This 1-bit field, when coded with the value '1', indicates that decoder configuration information is present in the metadata Access Unit carried in this metadata section.

**metadata\_section\_length:** This 12-bit field shall specify the number of remaining bytes in the section immediately following the metadata\_section\_length field, and including the CRC. The value of this field shall not exceed 4093 (0xFFD).

**metadata\_service\_id:** This 8-bit field identifies the metadata service associated with the metadata Access Unit carried in this metadata section. Each Metadata Table may contain metadata from multiple metadata services.

**section\_fragment\_indication:** This 2-bit field conveys information on the fragmentation of the metadata Access unit carried in this metadata section, corresponding to Table 2-159.

**Table 2-159 – Section fragment indication**

Value	Description
'11'	A single metadata section carrying a complete metadata Access Unit.
'10'	The first metadata section from a series of metadata sections with data from one metadata Access Unit.
'01'	The last metadata section from a series of metadata sections with data from one metadata Access Unit.
'00'	A metadata section from a series of metadata sections with data from one metadata Access Unit, but neither the first nor the last one.

**version\_number:** This 5-bit field is the version number of the whole Metadata Table. The version number shall be incremented by 1 modulo 32 whenever the information contained within the Metadata Table changes. When the current\_next\_indicator is set to '1', then the version\_number shall be that of the currently applicable Metadata Table. When the current\_next\_indicator is set to '0', then the version\_number shall be that of the next applicable Metadata Table.

**current\_next\_indicator:** A 1-bit field, which when set to '1' indicates that the Metadata Table sent is currently applicable. When the bit is set to '0', it indicates that the Metadata Table sent is not yet applicable and shall be the next Metadata Table to become valid.

**section\_number:** This 8-bit field gives the number of the metadata section. The section\_number of the first section in a Metadata Table shall be 0x00. The section\_number shall be incremented by 1 with each additional section in this Metadata Table.

**last\_section\_number:** This 8-bit field specifies the number of the last section (that is, the section with the highest section\_number) of the complete Metadata Table of which this section is a part.

**metadata\_byte:** This 8-bit contains contiguous bytes from a metadata Access Unit.

**CRC\_32:** This 32-bit field shall contain the CRC value that gives a zero output of the registers in the decoder defined in Annex A after processing the entire metadata\_section.

### 2.12.7 Use of the DSM-CC data carousel to transport metadata

The DSM-CC tools as defined in ISO/IEC 13818-6 for Data Carousels can be used if a carousel delivery mechanism is required without the need to express the hierarchical organization of the metadata structure in the transport mechanism. Information on the carousel in which the metadata is contained, is included in the metadata descriptor defined in 2.6.60 and 2.6.62. A specific stream\_type value is assigned to signal carriage of metadata in the DSM-CC data carousel. Note that signalling of metadata services within a DSM-CC data carousel is required, but not defined by this Specification.

### 2.12.8 Use of the DSM-CC object carousel to transport metadata

If a carousel delivery mechanism is required with the capability to express the hierarchical organization of the metadata structure in the transport, then the DSM-CC tools and file structures as defined in ISO/IEC 13818-6 for User to User Object Carousels can be used. These file structures provide the tools to structure the metadata as deemed appropriate for efficient parsing of the metadata and for expressing the hierarchical organization of the metadata. Information needed to identify the carousel in which the metadata is contained, is included in the metadata descriptor defined in 2.6.60 and 2.6.61. This may be the IOP:IOR() as defined in 11.3.1 and 5.7.2.3 of ISO/IEC 13818-6 DSM-CC. A specific stream\_type value is assigned to signal carriage of metadata in the DSM-CC object carousel. Note that signalling of metadata services within a DSM-CC object carousel is required, but not defined by this Specification.

### 2.12.9 Metadata-related signalling

#### 2.12.9.1 General

Metadata-related signalling covers four distinct areas:

- signalling of metadata services and streams;
- signalling of content for use by a metadata system;
- association of metadata to content; and
- signalling of decoder configuration data.

### 2.12.9.2 Signalling of metadata services and streams

Carriage of metadata is signalled by a `stream_type` value in the inclusive range from 0x15 to 0x19, specifying which of the five methods described in 2.12.4 to 2.12.8 is used to transport the metadata, and if appropriate, by a `stream_id` value of 0xFC indicating a metadata stream.

To uniquely identify a metadata service a `metadata_service_id` value is assigned to each such service by the transport; the assigned value shall be unique within the transport or program stream carrying the metadata service. If the metadata is carried in PES packets with a `stream_id` of 0xFC, or in metadata sections, or in ISO/IEC 13818-6 synchronized download sections, the assigned `metadata_service_id` value is signalled explicitly in the header of the `metadata_AU_cell` or the metadata section. If a ISO/IEC 13818-6 carousel is used to carry the metadata, then the signalling of metadata services is left to the application. The metadata descriptor specifies the format of the metadata and provides information on the decoder configuration data, and is linked to the metadata service by carrying information on the metadata service it is associated with.

### 2.12.9.3 Signalling of content for use by a metadata system

In 2.6.56 and 2.6.57, a content labelling descriptor is defined that can be used to assign a metadata application format specific reference, the `content_reference_id_record`, to audiovisual or any other content carried over an MPEG-2 transport stream or program stream. The `content_reference_id_record` can be used by the metadata system as a label to refer to such content. The content may represent, for example, a program or a stream or segments thereof. The content labelling descriptor also provides information on the content time base used for time referencing from the metadata, including the constant offset in time between the metadata time base and the applied content time base. The descriptor allows carriage of private data. The `metadata_application_format` may define constraints on the `content_reference_record`, such as constraints on the time period during which it is valid.

### 2.12.9.4 Association of metadata to content

In 2.6.58 and 2.6.59 the metadata pointer descriptor is defined to associate a single metadata service to audiovisual or any other content in a Rec. ITU-T H.222.0 | ISO/IEC 13818-1 stream. The metadata is associated with the content within the context as defined by the location of the descriptor. In a transport stream, the descriptor may be located in the PMT in the descriptor loop for either the program or an elementary stream, but may also be located in tables not defined in this Specification, such as tables describing bouquets of broadcast services.

The metadata pointer descriptor points from the content's context to the metadata service associated with that content. The descriptor provides the value of the `metadata_service_id` that is assigned to the associated metadata service, as well as one or more locations of the associated metadata. The location may for example be within the same transport stream as the content, or within another transport stream, but also at a non-Rec. ITU-T H.222.0 | ISO/IEC 13818-1 stream location such as the Internet.

### 2.12.9.5 Signalling decoder configuration data

Decoding of metadata may require the availability of metadata decoder configuration data. If needed, decoder configuration data shall be contained in one of the metadata services in the same program in the same Rec. ITU-T H.222.0 | ISO/IEC 13818-1 stream as the metadata service. If decoder configuration data is needed to decode a metadata service, then the metadata descriptor either carries such data or provides the information on retrieval of the decoder configuration data from the same or another metadata service. In a transport stream such other service can be found by searching in the PMT for a `metadata_descriptor` with the `metadata_service_id` as specified in the `decoder_config_metadata_service_id` field (and with the same `metadata_format` and the same `metadata_application_format`).

### 2.12.9.6 Overview of metadata signalling

Figure 2-11 provides an example of metadata signalling, in which a single program, the "content program", carries the content (or essence) while the metadata is carried in a separate program, the "metadata program". In this example, the metadata program and the content program exist on the same transport stream.

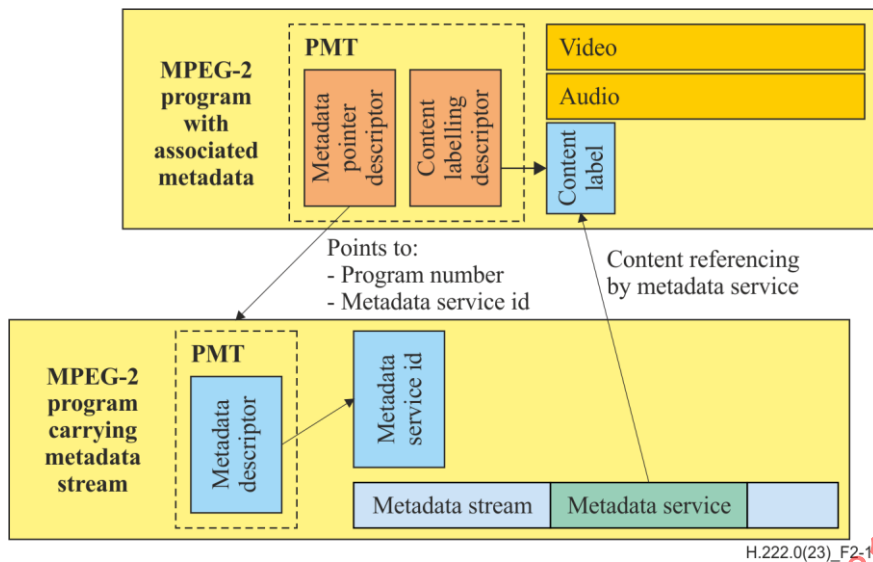

Figure 2-11 – Metadata signalling and referencing

In the content program there are two metadata-related descriptors, the content\_labelling descriptor and the metadata\_pointer descriptor. The content\_labelling descriptor associates a label, illustrated in the diagram by "content label" and encoded in the descriptor in the content\_reference\_id fields, with the content. The label can then be used by the metadata service to refer to the essence, either in whole, in part, or by a time-described segment. For example, the content\_labelling descriptor could provide the label "News of 1/1/02", and the metadata could then refer to a specific story item in the "News of 1/1/02", for example by providing the specific timing of the story item.

The metadata pointer descriptor provides information of where the metadata service can be found for the given content. In this example, the metadata is carried in a separate program, but it would be equally valid to have the metadata carried in the same program as the content, or provided by some means beyond the scope of this Specification, for instance from a URL. This descriptor also provides the metadata\_service\_id value that is assigned to the metadata service. This is required since a metadata stream could carry multiple metadata services for many different programs and each program needs to be able to uniquely identify its own metadata service.

In the metadata program, the metadata\_descriptor signals to which metadata service within a metadata stream it applies. If used, the metadata\_descriptor provides details of where to find the decoder configuration information.

Upon identifying a metadata pointer descriptor in the PMT by a receiver decoding the content program, the receiver retrieves the metadata\_descriptor from the metadata program. If needed first the decoder configuration data is retrieved, then the decoder is configured accordingly, after which the metadata service can start being decoded.

2.12.10 STD model for metadata

The STD model specifies normative constraints on Rec. ITU-T H.222.0 | ISO/IEC 13818-1 streams that carry metadata. For decoding of metadata in the STD, the regular T-STD and P-STD models are applicable with buffer  $B_n$ , input rate  $R_{x_n}$  of the metadata into  $B_n$  and output rate  $R_{metadata}$  out of  $B_n$  and into  $D_{metadata}$ , the metadata decoder. See Figure 2-12.

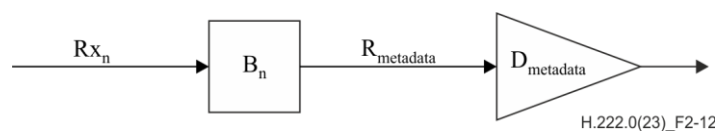

Figure 2-12 – Metadata decoding in the STD

The metadata enters buffer  $B_n$  at rate  $R_{x_n}$ . In the P-STD, rate  $R_{x_n}$  equals the rate of the program stream. In the T-STD, rate  $R_{x_n}$  is the rate out of  $TB_n$  and equal to the rate defined by the metadata\_input\_leak\_rate field in the metadata STD descriptor. The size  $BS_n$  of buffer  $B_n$  is equal to the size defined in the metadata\_buffer\_size field in the metadata STD descriptor. In case of synchronous delivery, metadata decoding is instantaneous and controlled by PTSs. At decode time, that is when the STC equals the PTS, the associated metadata is removed instantaneously from  $B_n$ . In case of asynchronous delivery, the metadata is removed from  $B_n$  at a rate  $R_{metadata}$  equal to the rate defined by the metadata\_output\_leak\_rate field in the metadata STD descriptor. Buffer  $B_n$  shall not overflow.

Note that the STD model defines constraints on the delivery of the metadata, without specifying any constraint on the timing used in the metadata.

## 2.13 Carriage of ISO 15938 data

### 2.13.1 Introduction

Carriage of metadata over a Rec. ITU-T H.222.0 | ISO/IEC 13818-1 stream as defined in 2.12 allows for carriage of ISO 15938 data by appropriate coding of the metadata\_format field. In this subclause, for the purpose to transport ISO 15938 data, a specific instance is defined. Carriage of ISO 15938 data shall meet each requirement defined in 2.12, but in addition the requirements defined in this subclause shall apply for transport of ISO 15938 data.

### 2.13.2 ISO 15938 decoder configuration data

Decoding of ISO 15938 data requires the availability of decoder configuration data. Consequently, when ISO 15938 data is carried in a Rec. ITU-T H.222.0 | ISO/IEC 13818-1 stream, then the metadata descriptor shall signal carriage of associated decoder configuration data in the same Rec. ITU-T H.222.0 | ISO/IEC 13818-1 stream by coding a value of the decoder\_config\_flags of either '001' or '010' or '011' or '100'.

## 2.14 Carriage of Rec. ITU-T H.264 | ISO/IEC 14496-10 video

### 2.14.1 Introduction

This Specification defines the carriage of Rec. ITU-T H.264 | ISO/IEC 14496-10 elementary stream within Rec. ITU-T H.222.0 | ISO/IEC 13818-1 systems, both for program and transport streams. Typically, a Rec. ITU-T H.264 | ISO/IEC 14496-10 stream will be an element of a Rec. ITU-T H.222.0 | ISO/IEC 13818-1 program, as defined by the PMT in a transport stream and the PSM in a program stream. The carriage and buffer management of AVC video streams is defined using existing parameters from this Recommendation | International Standard such as PTS and DTS, as well as information present within an AVC video stream.

Carriage of AVC video streams in a Rec. ITU-T H.222.0 | ISO/IEC 13818-1 stream defines accurate mapping between STD parameters and HRD parameters that may be present in an AVC video stream. Requirements are defined for the presence of HRD parameters in the AVC video stream, to ensure that it can be verified whether each STD requirement is met for each AVC video stream carried in a transport stream or a program stream.

NOTE 1 – Though the timing information present in the AVC video stream may not use a 90-kHz clock, the PTS and DTS timestamps need to be expressed in units of 90 kHz.

When a Rec. ITU-T H.264 | ISO/IEC 14496-10 stream is carried in a Rec. ITU-T H.222.0 | ISO/IEC 13818-1 stream, the Rec. ITU-T H.264 | ISO/IEC 14496-10 coded data shall be contained in PES packets. The Rec. ITU-T H.264 | ISO/IEC 14496-10 coded data shall comply with the byte stream format defined in Annex B of Rec. ITU-T H.264 | ISO/IEC 14496-10, with the following constraints:

- Each AVC access unit shall contain an access unit delimiter NAL Unit;  
NOTE 2 – Rec. ITU-T H.264 | ISO/IEC 14496-10 requires that an access unit delimiter NAL Unit, if present, is the first NAL Unit within an AVC access unit. Access unit delimiter NAL Units simplify the ability to detect the boundary between pictures; they avoid the need to process the content of slice headers, and they are particularly useful for the Baseline and Extended profiles where slice order can be arbitrary.
- All Sequence and Picture Parameter Sets (SPS and PPS) necessary for decoding the AVC video stream shall be present within that AVC video stream.  
NOTE 3 – Rec. ITU-T H.264 | ISO/IEC 14496-10 also allows delivery of SPS and PPS by external means. This Specification does not provide support for such delivery, and therefore requires SPS and PPS to be carried within the AVC video stream.
- Each AVC video sequence that contains hrd\_parameters() with the low\_delay\_hrd\_flag set to '1', shall carry VUI parameters in which the timing\_info\_present\_flag shall be set to '1'.  
NOTE 4 – If the low\_delay\_hrd\_flag is set to '1', then buffer underflow is allowed to occur in the STD model; see 2.14.3 and 2.14.4. Setting the timing\_info\_present\_flag to '1' ensures that the AVC video stream contains sufficient information to determine the DPB output time and the CPB removal time of AVC access units, also in case of underflow.

To provide display specific information such as aspect\_ratio, it is strongly recommended that each AVC video stream carries VUI parameters with sufficient information to ensure that the decoded AVC video stream can be displayed correctly by receivers.

When an AVC video stream conforms to one or more profiles defined in Annex G of Rec. ITU-T H.264 | ISO/IEC 14496-10, the following constraints additionally apply:

- The AVC video sub-bitstream of SVC as defined in 2.1.10 shall be an element of a Rec. ITU-T H.222.0 | ISO/IEC 13818-1 program and the stream\_type for this elementary stream shall be equal to 0x1B.
- For each SVC video sub-bitstream as defined in 2.1.142 that is an element of the same Rec. ITU-T H.222.0 | ISO/IEC 13818-1 program, the stream\_type for this elementary stream shall be equal to 0x1F.
- All subset Sequence Parameter Sets and Picture Parameter Sets necessary for decoding an SVC video sub-bitstream shall be present within the elementary stream carrying the SVC video sub-bitstream.
- In each elementary stream with stream\_type equal to 0x1F, exactly one VDRD\_drd\_nal\_unit as defined in 2.14.3.3 may precede all the NAL units of the same SVC dependency representation.
 

NOTE 5 – If any VDRD\_drd\_nal\_unit is included in any SVC dependency representation then the HRD model should include this VDRD\_drd\_nal\_unit in the buffer model as additional non-VCL NAL units. The NAL unit type 24 may be used in a different way by other specifications out of scope of this Specification. When carrying AVC base and SVC enhancement layers in different elementary streams, usage of VDRD is strongly recommended if access units are not aligned with PES packets.
- The TREF field as defined in 2.4.3.7 may be present in the PES headers of elementary streams with stream\_type equal to 0x1F. The TREF field shall be set and shall be present in the PES headers as specified in 2.14.3.5 and 2.14.3.6 respectively.
 

NOTE 6 – Currently the presence of TREF is only specified for elementary streams with stream\_type equal to 0x1F.
- When a Rec. ITU-T H.222.0 | ISO/IEC 13818-1 program includes more than one SVC video sub-bitstream, or more than one AVC video sub-bitstream of SVC and at least one SVC video sub-bitstream, a hierarchy descriptor as defined in 2.6.7 shall be used to indicate the dependencies of the related video sub-bitstreams.
- All NAL units of a re-assembled AVC access unit shall be passed to the decoder in the order of NAL units within an access unit as defined in Rec. ITU-T H.264 | ISO/IEC 14496-10.
 

NOTE 7 – If SEI NAL units are present in any SVC dependency representation of an SVC video sub-bitstream, these NAL units may require re-ordering to the order of NAL units within an access unit as defined in Rec. ITU-T H.264 | ISO/IEC 14496-10 before access unit re-assembling.
- The profile and level limitations indicated by profile\_idc and level\_idc syntax elements in the AVC\_video\_descriptor, if present, and the Type II HRD parameters in the AVC\_timing\_and\_HRD\_descriptor, if present, for an AVC video stream resulting from re-assembling (up to) the video sub-bitstream associated with the descriptors shall include NAL units with nal\_unit\_type syntax element equal to 14 in the AVC video sub-bitstream of SVC and, if present in the SVC video sub-bitstream, NAL units with nal\_unit\_type syntax element equal to 24.

When an AVC video stream conforms to one or more profiles defined in Annex H of Rec. ITU-T H.264 | ISO/IEC 14496-10, the following constraints additionally apply:

- The AVC video sub-bitstream of MVC or MVC base view sub-bitstream, as defined in 2.1.9 and 2.1.103, shall be an element of a Rec. ITU-T H.222.0 | ISO/IEC 13818-1 program and the stream\_type for this elementary stream shall be equal to 0x1B.
- For each MVC video sub-bitstream, as defined in 2.1.106, that is an element of the same Rec. ITU-T H.222.0 | ISO/IEC 13818-1 program, the stream\_type for this elementary stream shall be equal to 0x20.
- Each MVC video sub-bitstream shall be associated with one or more consecutive view order index values.
 

NOTE – According to the definitions in 2.1.106 and 2.1.103, respectively, an MVC video sub-bitstream or MVC base view sub-bitstream does not necessarily include view components for all view\_id values included in one MVC view\_id subset if one or more views are not required for decoding the transmitted views. As an example, consider a MVC bitstream having 4 views V1, V2, V3, and V4 in ascending order of view order index, where view V1 is the base view, view V2 is depending directly on V1, V3 is depending directly on V1 and V2, and V4 is depending directly on V2. Using such encoded views, two MVC sub-bitstreams M1 and M2 may be created as follows: M1 is associated with the output views V1 and V2, and M2 with the output view V4. In this example, it is possible that only M1 and M2 are transmitted to a receiver, thus sub-bitstream for V3 is not required to be transmitted since a combination of both sub-bitstreams M1 and M2 refers to the set of views V1, V2 and V4, and can be decoded without the presence of V3.
- Each view order index value shall be associated with exactly one MVC view\_id subset.
 

NOTE 8 – This restriction greatly simplifies the re-assembly of any decodable sub-bitstream.
- When a Rec. ITU-T H.222.0 | ISO/IEC 13818-1 program includes more than one MVC video sub-bitstream or more than one AVC video sub-bitstream of MVC and at least one MVC video sub-bitstream, one or more hierarchy descriptors as defined in 2.6.6 and 2.6.7 shall be used to indicate the dependencies of the related video sub-bitstreams. If more than one hierarchy descriptor is present for one elementary stream, the value of the syntax element hierarchy\_layer\_index shall be the same within the same elementary stream. The syntax element hierarchy\_type shall be set to the value 9 or 15.

NOTE – Provided an MVC video sub-bitstream B depends on video sub-bitstream A and this dependency is indicated using a hierarchy descriptor, further an MVC video sub-bitstream C depends on B and this dependency is also indicated using a second hierarchy descriptor, then this implicitly indicates a dependency of C on A and no third hierarchy descriptor is needed.

- The subset sequence parameter sets and picture parameter sets necessary for decoding an MVC video sub-bitstream shall be present within the elementary stream carrying the MVC video sub-bitstream.
- In each elementary stream with stream type equal to 0x20 exactly one VDRD\_nal\_unit, as defined in 2.14.3.3, may precede all the NAL units of the same MVC view-component subset.
 

NOTE 9 – If any VDRD\_nal\_unit is included in any MVC view component subset, then the HRD model should include this VDRD\_nal\_unit in the buffer model as additional non-VCL NAL units. The NAL unit type 24 may be used in a different way by other specifications out of scope of this Specification.
- All NAL units of a re-assembled AVC access unit shall be passed to the decoder in the order of NAL units within an access unit, as defined in Rec. ITU-T H.264 | ISO/IEC 14496-10.
 

NOTE 10 – If SEI NAL units are present in any MVC view-component subset of an MVC video sub-bitstream, these NAL units may require re-ordering to the order of NAL units within an access unit, as defined in Rec. ITU-T H.264 | ISO/IEC 14496-10 before access unit re-assembling.
- The profile\_idc and level\_idc indication in the AVC\_video\_descriptor, if present, and the Type II HRD parameters in the AVC\_timing\_and\_HRD\_descriptor, if present, for an AVC video stream resulting from re-assembling (up to) the MVC video sub-bitstream associated with the descriptors shall include NAL units with nal\_unit\_type syntax element equal to 14, if present, in the AVC video sub-bitstream of MVC or MVC base view sub-bitstream and, if present, in the MVC video sub-bitstream, NAL units with nal\_unit\_type syntax element equal to 20 and 24.

When an AVC video stream conforms to one or more profiles defined in Annex I of Rec. ITU-T H.264 | ISO/IEC 14496-10, the following constraints additionally apply:

- The AVC video sub-bitstream of MVCD or MVCD base view sub-bitstream, as defined in 2.1.10 and 2.1.108, shall be an element of a Rec. ITU-T H.222.0 | ISO/IEC 13818-1 program and the stream\_type for this elementary stream shall be equal to 0x1B.
- For each MVCD video sub-bitstream, as defined in 2.1.110, that is an element of the same Rec. ITU-T H.222.0 | ISO/IEC 13818-1 program, the stream\_type for this elementary stream shall be equal to 0x26.
- Each MVCD video sub-bitstream shall be associated with one or more consecutive view order index values.
- Each view order index value shall be associated to exactly one MVCD view\_id subset.

NOTE 11 – This restriction greatly simplifies the re-assembly of any decodable sub-bitstream.

- The subset sequence parameter sets and picture parameter sets necessary for decoding an MVCD video sub-bitstream shall be present within the elementary stream carrying the MVCD video sub-bitstream.
- In each elementary stream with stream type equal to 0x26 exactly one VDRD\_nal\_unit, as defined in 2.14.3.3, may precede all the NAL units of the same MVCD view-component subset.
 

NOTE 12 – If any VDRD\_nal\_unit is included in any MVCD view component subset, then the HRD model should include this VDRD\_nal\_unit in the buffer model as additional non-VCL NAL units. The NAL unit type 24 may be used in a different way by other specifications out of scope of this Specification.
- All NAL units of a re-assembled AVC access unit shall be passed to the decoder in the order of NAL units within an access unit, as defined in Rec. ITU-T H.264 | ISO/IEC 14496-10.

NOTE 13 – If SEI NAL units are present in any MVCD view-component subset of an MVCD video sub-bitstream, these NAL units may require re-ordering to the order of NAL units within an access unit, as defined in Rec. ITU-T H.264 | ISO/IEC 14496-10 before access unit re-assembling.

## 2.14.2 Carriage in PES packets

Rec. ITU-T H.264 | ISO/IEC 14496-10 Video is carried in PES packets as PES\_packet\_data\_bytes, using one of the 16 stream\_id values assigned to video, while signalling the Rec. ITU-T H.264 | ISO/IEC 14496-10 Video stream by means of the assigned stream-type value in the PMT or PSM (see Table 2-34). The highest level that may occur in an AVC video stream as well as a profile that the entire stream conforms to should be signalled using the AVC video descriptor. If an AVC video descriptor is associated with an AVC video stream, then this descriptor shall be conveyed in the descriptor loop for the respective elementary stream entry in the Program Map Table in case of a transport stream or in the Program Stream Map, when PSM is present, in case of a program stream. This Recommendation | International Standard does not specify presentation of Rec. ITU-T H.264 | ISO/IEC 14496-10 streams in the context of a program.

For PES packetization, no specific data alignment constraints apply. For synchronization and STD management, PTSs and, when appropriate, DTSSs are encoded in the header of the PES packet that carries the Rec. ITU-T H.264 |

ISO/IEC 14496-10 video elementary stream data. For PTS and DTS encoding, the constraints and semantics apply as defined in 2.4.3.7 and 2.7.

### 2.14.3 STD extensions

#### 2.14.3.1 T-STD extensions

The T-STD model includes a transport buffer  $TB_n$  and a multiplex buffer  $MB_n$  prior to buffer  $EB_n$  for decoding of each AVC video elementary stream  $n$  conforming to one or more profiles defined in Annex A of Rec. ITU-T H.264 | ISO/IEC 14496-10 video elementary stream  $n$ . See Figure 2-13.

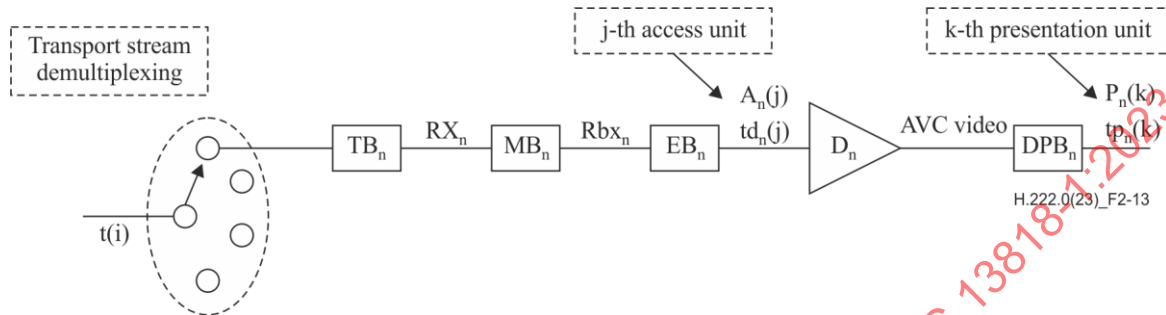

Figure 2-13 – T-STD model extensions for Rec. ITU-T H.264 | ISO/IEC 14496-10 video

NOTE – For carriage of AVC streams according to High, Progressive High, Constrained High, High 10, High 4:2:2, High 4:4:4 Predictive, High 10 Intra, High 4:2:2 Intra, High 4:4:4 Intra, or CAVLC 4:4:4 Intra profiles, bitrate and CPB buffer size limitations of this specification are more restrictive than the limits specified in Annex A of Rec. ITU-T H.264 | ISO/IEC 14496-10.

#### DPB<sub>n</sub> buffer management

Carriage of an AVC video stream over Rec. ITU-T H.222.0 | ISO/IEC 13818-1 does not impact the size of buffer  $DPB_n$ . For decoding of an AVC video stream in the STD the size of  $DPB_n$  is as defined in Rec. ITU-T H.264 | ISO/IEC 14496-10. The DPB buffer shall be managed as specified in Annex C of Rec. ITU-T H.264 | ISO/IEC 14496-10 (C.2 and C.4). A decoded AVC access unit enters  $DPB_n$  instantaneously upon decoding of the AVC access unit, hence at the CPB removal time of the AVC access unit. A decoded AVC access unit is presented at the DPB output time. If the AVC video stream provides insufficient information to determine the CPB removal time and the DPB output time of AVC access units, then these time instants shall be determined in the STD model from PTS and DTS timestamps as follows:

- 1) The CPB removal time of AVC access unit  $n$  is the instant in time indicated by  $DTS(n)$  where  $DTS(n)$  is the DTS value of AVC access unit  $n$ .
- 2) The DPB output time of AVC access unit  $n$  is the instant in time indicated by  $PTS(n)$  where  $PTS(n)$  is the PTS value of AVC access unit  $n$ .

NOTE 1 – AVC video sequences in which the `low_delay_hrd_flag` in `hrd_parameters()` is set to 1 carry sufficient information to determine the DPB output time and the CPB removal time of each AVC access unit. Hence for AVC access units for which STD underflow may occur, the CPB removal time and the DPB output time are defined by HRD parameters, and not by DTS and PTS timestamps.

#### TB<sub>n</sub>, MB<sub>n</sub> and EB<sub>n</sub> buffer management

The input to buffer  $TB_n$  and its size  $TBS_n$  are specified in 2.4.2.4. For buffers  $MB_n$  and  $EB_n$ , and for the rate  $R_{X_n}$  between  $TB_n$  and  $MB_n$  and the rate  $R_{bx_n}$  between  $MB_n$  and  $EB_n$  the following constraints apply for carriage of a Rec. ITU-T H.264 | ISO/IEC 14496-10 stream:

Size  $EBS_n$  of buffer  $EB_n$ :

$$EBS_n = \text{cpb\_size}$$

Where `cpb_size` is the size `CpbSize[cpb_cnt_minus1]` of the CPB for the byte stream format signalled in the NAL `hrd_parameters()` carried in VUI parameters in the AVC video stream. If NAL `hrd_parameters()` are not present in the AVC video stream, then the `cpb_size` shall be the size defined as  $1200 \times \text{MaxCPB}$  in Annex A of Rec. ITU-T H.264 | ISO/IEC 14496-10 for the level of the AVC video stream.

Size  $MBS_n$  of Buffer  $MB_n$ :

$$MBS_n = BS_{\text{mux}} + BS_{\text{oh}} + 1200 \times \text{MaxCPB}[\text{level}] - \text{cpb\_size}$$

where  $BS_{\text{oh}}$ , packet overhead buffering, is defined as:

$$BS_{oh} = (1/750) \text{ seconds} \times \max\{1200 \times \text{MaxBR}[\text{level}], 2\,000\,000 \text{ bit/s}\}$$

and  $BS_{mux}$ , additional multiplex buffering, is defined as:

$$BS_{mux} = 0.004 \text{ seconds} \times \max\{1200 \times \text{MaxBR}[\text{level}], 2\,000\,000 \text{ bit/s}\}$$

where  $\text{MaxCPB}[\text{level}]$  and  $\text{MaxBR}[\text{level}]$  are defined for the byte stream format in Table A.1 (Level Limits) in Rec. ITU-T H.264 | ISO/IEC 14496-10 for the level of the AVC video stream, and

where  $\text{cpb\_size}$  is the size  $\text{CpbSize}[\text{cpb\_cnt\_minus1}]$  of the CPB for the byte stream format signalled in the NAL  $\text{hrd\_parameters}()$  carried in VUI parameters in the AVC video stream. If NAL  $\text{hrd\_parameters}()$  are not present in the AVC video stream, then the  $\text{cpb\_size}$  shall be the size  $1200 \times \text{MaxCPB}$  defined in Annex A of Rec. ITU-T H.264 | ISO/IEC 14496-10 for the level of the AVC video stream.

Rate  $Rx_n$ :

when there is no data in  $TB_n$  then  $Rx_n$  is equal to zero.

Otherwise:  $Rx_n = \text{bit\_rate}$

where  $\text{bit\_rate}$  is  $1.2 \times \text{BitRate}[\text{SchedSelIdx}]$  of data flow into the CPB for the byte stream format and  $\text{BitRate}[\text{SchedSelIdx}]$  is as defined in Annex E of Rec. ITU-T H.264 | ISO/IEC 14496-10.

NOTE 2 – Annex E specifies the values for  $\text{BitRate}[\text{SchedSelIdx}]$  when NAL  $\text{hrd\_parameters}()$  is present in the VUI parameters of the AVC video stream and default values for  $\text{BitRate}[\text{SchedSelIdx}]$  based on profile and level when NAL  $\text{hrd\_parameters}()$  is not present.

#### **Transfer between $MB_n$ and $EB_n$**

If the  $\text{AVC\_timing\_and\_HRD\_descriptor}$  is present with the  $\text{hrd\_management\_valid\_flag}$  set to '1', then the transfer of data from  $MB_n$  to  $EB_n$  shall follow the HRD defined scheme for data arrival in the CPB as defined in Annex C of Rec. ITU-T H.264 | ISO/IEC 14496-10.

Otherwise, the leak method shall be used to transfer data from  $MB_n$  to  $EB_n$  as follows:

Rate  $Rbx_n$ :

$$Rbx_n = 1200 \times \text{MaxBR}[\text{level}]$$

where  $\text{MaxBR}[\text{level}]$  is defined for the byte stream format in Table A.1 (Level Limits) in Rec. ITU-T H.264 | ISO/IEC 14496-10 for each level.

If there is PES packet payload data in  $MB_n$ , and buffer  $EB_n$  is not full, the PES packet payload is transferred from  $MB_n$  to  $EB_n$  at a rate equal to  $Rbx_n$ . If  $EB_n$  is full, data are not removed from  $MB_n$ . When a byte of data is transferred from  $MB_n$  to  $EB_n$ , all PES packet header bytes that are in  $MB_n$  and precede that byte, are instantaneously removed and discarded. When there is no PES packet payload data present in  $MB_n$ , no data is removed from  $MB_n$ . All data that enters  $MB_n$  leaves it. All PES packet payload data bytes enter  $EB_n$  instantaneously upon leaving  $MB_n$ .

#### **Removal of AVC access units from $EB_n$**

Each AVC access unit  $A_n(j)$  that is present in  $EB_n$  is removed instantaneously at time  $td_n(j)$ . The decoding time  $td_n(j)$  is specified by the DTS or from the CPB removal time, as derived from information in the AVC video stream.

#### **STD delay**

The total delay of any Rec. ITU-T H.264 | ISO/IEC 14496-10 data other than AVC still picture data through the System Target Decoders buffers  $TB_n$ ,  $MB_n$ , and  $EB_n$  shall be constrained by  $td_n(j) - t(i) \leq 10$  seconds for all  $j$ , and all bytes  $i$  in AVC access unit  $A_n(j)$ .

The delay of any AVC still picture data through the System Target Decoders buffers  $TB_n$ ,  $MB_n$ , and  $EB_n$  shall be constrained by  $td_n(j) - t(i) \leq 60$  seconds for all  $j$ , and all bytes  $i$  in AVC access unit  $A_n(j)$ .

#### **Buffer management conditions**

Transport streams shall be constructed so that the following conditions for buffer management are satisfied:

- $TB_n$  shall not overflow and shall be empty at least once every second.
- $MB_n$ ,  $EB_n$ , and  $DPB_n$  shall not overflow.

- $EB_n$  shall not underflow, except when VUI parameters are present for the AVC video sequence with the `low_delay_hrd_flag` set to '1'. Underflow of  $EB_n$  occurs for AVC access unit  $A_n(j)$  when one or more bytes of  $A_n(j)$  are not present in  $EB_n$  at the decoding time  $td_n(j)$ .

NOTE 3 – An AVC video stream may carry information to determine compliance of the AVC video stream to the HRD, as specified in Annex C of Rec. ITU-T H.264 | ISO/IEC 14496-10. The presence of this information can be signalled in a transport stream using the AVC timing and HRD descriptor with the `hrd_management_valid_flag` set to '1'. Irrespective of the presence of this information, compliance of an AVC video stream to the T-STD ensures that HRD buffer management requirements for  $CPB_n$  are met when each byte in the AVC video stream is delivered to and removed from  $CPB_n$  in the HRD at exactly the same instant in time at which the byte is delivered to and removed from  $EB_n$  in the T-STD.

### 2.14.3.2 P-STD extensions

The P-STD model for the decoding of an AVC video elementary stream  $n$  conforming to one or more profiles defined in Annex A of Rec. ITU-T H.264 | ISO/IEC 14496-10 elementary stream includes a multiplex buffer  $B_n$  and a decoder  $D_n$  followed by a buffer  $DPB_n$  (see Figure 2-14). For each AVC video stream  $n$ , the size  $BS_n$  of buffer  $B_n$  in the P-STD is defined by the `P-STD_buffer_size` field in the PES packet header.

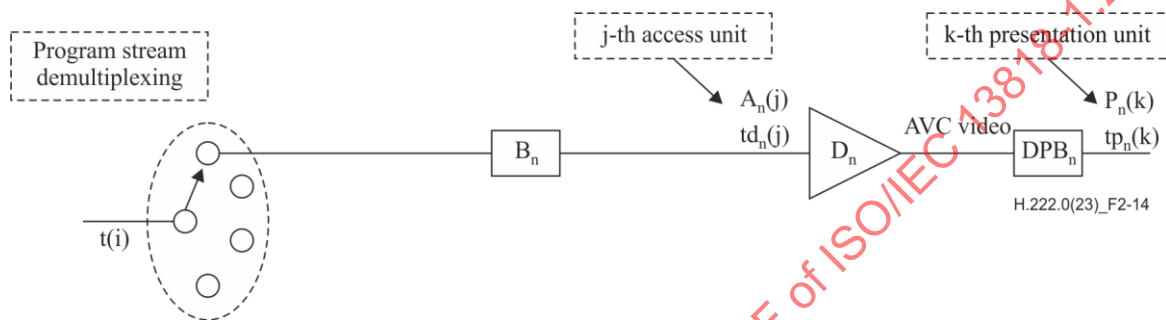

Figure 2-14 – P-STD model extensions for Rec. ITU-T H.264 | ISO/IEC 14496-10 video

#### DPB<sub>n</sub> buffer management

Buffer  $DPB_n$  shall be managed in exactly the same way as in the T-STD; see 2.14.3.1.

#### B<sub>n</sub> buffer management

The AVC access unit data enters buffer  $B_n$  as specified in 2.5.2.2. At time  $td_n(j)$ , AVC access unit  $A_n(j)$  is decoded and instantaneously removed from  $B_n$ . The decoding time  $td_n(j)$  is specified by the DTS or by the CPB removal time, derived from information in the AVC video stream. Upon decoding, the AVC access unit instantaneously enters  $DPB_n$  or is output without entry into  $DPB_n$ , according to the rules specified in Rec. ITU-T H.264 | ISO/IEC 14496-10.

#### STD delay

The total delay of any Rec. ITU-T H.264 | ISO/IEC 14496-10 data other than AVC still picture data through the System Target Decoders buffer  $B_n$  shall be constrained by  $td_n(j) - t(i) \leq 10$  seconds for all  $j$ , and all bytes  $i$  in AVC access unit  $A_n(j)$ .

The delay of any AVC still picture data through the System Target Decoders buffer  $B_n$  shall be constrained by  $td_n(j) - t(i) \leq 60$  seconds for all  $j$ , and all bytes  $i$  in AVC access unit  $A_n(j)$ .

#### Buffer management conditions

Program streams shall be constructed so that the following conditions for buffer management are satisfied:

- $B_n$  shall not overflow.
- $B_n$  shall not underflow, except when VUI parameters are present for the AVC video sequence with the `low_delay_hrd_flag` set to '1' or when `trick_mode` status is true. Underflow of  $B_n$  occurs for AVC access unit  $A_n(j)$  when one or more bytes of  $A_n(j)$  are not present in  $B_n$  at the decoding time  $td_n(j)$ .

### 2.14.3.3 View and dependency representation delimiter NAL unit

See Table 2-160.

Table 2-160 – View and dependency representation delimiter NAL unit

Syntax	No. of bits	Mnemonic
VDRD_nal_unit() {		
<b>forbidden_zero_bit</b>	<b>1</b>	<b>bslbf</b>
<b>nal_ref_idc</b>	<b>2</b>	<b>bslbf</b>
<b>nal_unit_type</b>	<b>5</b>	<b>bslbf</b>
}		

2.14.3.4 Semantics of view and dependency representation delimiter NAL unit

**forbidden\_zero\_bit** – shall be equal to 0x0

**nal\_ref\_idc** – shall be equal to 0x0

**nal\_unit\_type** – shall be equal to 0x18

2.14.3.5 T-STD extensions for SVC

The T-STD model described in 2.14.3.1 is applied if the received elementary stream is a video sub-bitstream of stream\_type 0x1B, i.e., only the AVC video sub-bitstream of SVC is received and decoded.

When there is a set of received video sub-bitstreams in a Rec. ITU-T H.222.0 | ISO/IEC 13818-1 program, for which dependencies may be signalled in the hierarchy\_descriptor as defined in 2.6.6, and when there is at least one of the video sub-bitstreams in the set of received elementary streams having the value of stream\_type equal to 0x1F, the T-STD model as described in 2.14.3.1 is extended as illustrated in Figure 2-15 and as specified below.

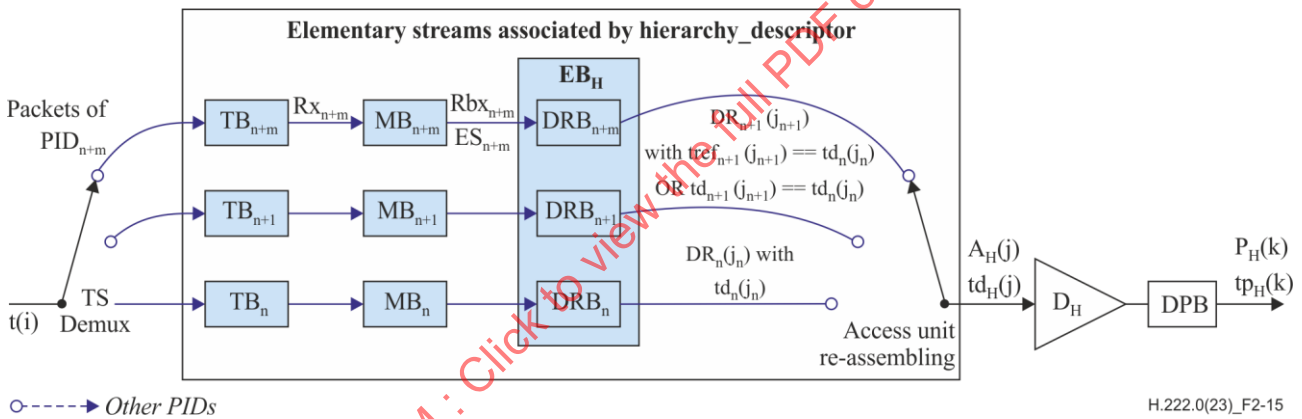

Figure 2-15 – T-STD model extensions for Rec. ITU-T H.264 | ISO/IEC 14496-10 video with scalable video sub-bitstreams

The following additional notations are used to describe the T-STD extensions and are illustrated in Figure 2-15.

- ES<sub>n</sub> is the received elementary stream associated with dependency\_id value equal to n
- ES<sub>H</sub> is the received elementary stream associated with the highest value H of dependency\_id present in the set of received elementary streams
- j is an index to the re-assembled access units
- j<sub>n</sub> is an index to the SVC dependency representations of the elementary stream associated with dependency\_id value equal to n
- DR<sub>n</sub>(j<sub>n</sub>) is the j<sub>n</sub>-th SVC dependency representation of video sub-bitstream associated with dependency\_id value equal to n
- A<sub>H</sub>(j) is the j-th access unit resulting from re-assembling (up to) the j<sub>H</sub>-th SVC dependency representations with dependency\_id value equal to H
- td<sub>n</sub>(j<sub>n</sub>) is the decoding time, measured in seconds, in the system target decoder of the j<sub>n</sub>-th SVC dependency representation of the video sub-bitstream associated with dependency\_id value equal to n
- td<sub>H</sub>(j) is the decoding time, measured in seconds, in the system target decoder of the j-th access unit A<sub>H</sub>(j) resulting from re-assembling (up to) the j<sub>H</sub>-th SVC dependency representations DR<sub>H</sub>(j<sub>H</sub>)

- $\text{tref}_n(j_n)$  is equal to the decoding time value  $\text{td}_{n-1}(j_{n-1})$  associated with the  $j_{n-1}$ -th SVC dependency representation  $\text{DR}_{n-1}(j_{n-1})$ , indicated by the TREF field of the PES header of the  $j_n$ -th SVC dependency representation  $\text{DR}_n(j_n)$  of the same access unit
- $\text{TB}_n$  is the transport buffer for elementary stream associated with  $\text{dependency\_id}$  value equal to  $n$
- $\text{TBS}_n$  is the size of the transport buffer  $\text{TB}_n$ , measured in bytes
- $\text{MB}_n$  is the multiplexing buffer for elementary stream associated with  $\text{dependency\_id}$  value equal to  $n$
- $\text{MBS}_n$  is the size of the multiplexing buffer  $\text{MB}_n$ , measured in bytes
- $\text{DRB}_n$  is the dependency representation buffer for elementary stream  $\text{ES}_n$
- $\text{DRBS}_n$  is the size of dependency representation buffer  $\text{DRB}_n$ , measured in bytes
- $\text{EB}_H$  is the elementary stream buffer for all video sub-bitstreams
- $\text{EBS}_H$  is the size of elementary stream buffer  $\text{EB}_H$ , measured in bytes
- $\text{RX}_n$  is the transfer rate from  $\text{TB}_n$  to  $\text{MB}_n$  as specified below
- $\text{Rbx}_n$  is the transfer rate from  $\text{MB}_n$  to  $\text{DRB}_n$  as specified below

### Carriage in PES packets

For correct re-assembling of the SVC dependency representations to an AVC access unit, if there is both an SVC dependency representation with any  $\text{dependency\_id}$  equal to  $n$  and an SVC dependency representation with  $\text{dependency\_id}$  equal to  $(n+1)$  in the same AVC access unit, the following applies:

- a PES packet per SVC dependency representation start shall be present, i.e., at most one SVC dependency representation may commence in the same PES packet;
- the PTS and, if applicable, the DTS value shall be provided in the PES header of each SVC dependency representation;
- if the DTS value of the SVC dependency representation with  $\text{dependency\_id}$  equal to  $n$  is different from the DTS value of the SVC dependency representation with  $\text{dependency\_id}$  equal to  $(n+1)$  of the same access unit, the TREF field as defined in 2.4.3.7 shall be present in the PES header extension of the SVC dependency representation with  $\text{dependency\_id}$  equal to  $(n+1)$  and the TREF field value shall be equal to the DTS value of the SVC dependency representation with  $\text{dependency\_id}$  equal to  $n$ .

### DPB buffer management

The DPB buffer management for the re-assembled AVC video stream shall conform to 2.14.3.1 using AVC access unit timing values, as DTS or CPB removal time, and PTS or DPB removal time, associated with the SVC dependency representations of the video sub-bitstream in elementary stream  $\text{ES}_H$ .

### $\text{TB}_n$ , $\text{MB}_n$ , $\text{EB}_n$ buffer management

The following applies:

- There is exactly one transport buffer  $\text{TB}$  as defined in 2.14.3.1 for each received elementary stream in the set of received video sub-bitstreams contained in elementary streams as shown in Figure 2-15.
- There is exactly one multiplexing buffer  $\text{MB}_0$  for the AVC video sub-bitstream of SVC in elementary stream  $\text{ES}_0$ , where the size of the multiplexing buffer  $\text{MBS}_0$  is constrained as follows:

$$\text{MBS}_0 = \text{BS}_{\text{mux},0} + \text{BS}_{\text{oh},0} + 1200 \times \text{MaxCPB}[\text{level}]_0 - \text{cpb\_size}_0$$

where  $\text{BS}_{\text{mux},0}$ ,  $\text{BS}_{\text{oh},0}$  are defined in 2.14.3.1 for the AVC video sub-bitstream of SVC in elementary stream  $\text{ES}_0$ ;

where  $\text{MaxCPB}[\text{level}]_0$  and  $\text{cpb\_size}_0$  for the elementary stream  $\text{ES}_0$  are defined as in 2.14.3.1.

NOTE 1 – If HRD parameters are present in at least one of the video sub-bitstreams, those parameters have to be carefully handled in order to not unnecessarily increase the multiplexing buffers allocation.

- There is exactly one multiplexing buffer  $\text{MB}_n$  for each received elementary stream associated with  $\text{dependency\_id}$  value not equal to 0, where the size of each multiplexing buffer  $\text{MBS}_n$  is constrained as follows:

$$\text{MBS}_n = \text{BS}_{\text{mux},n} + \text{BS}_{\text{oh},n}$$

where  $\text{BS}_{\text{mux},n}$ ,  $\text{BS}_{\text{oh},n}$  are defined in 2.14.3.1 for the AVC video stream resulting from re-assembling (up to) the SVC video sub-bitstream in elementary stream  $\text{ES}_n$ .

- There is exactly one elementary stream buffer  $EB_H$  for all the elementary streams in the set of received elementary streams as shown in Figure 2-15, of which the size  $EBS_H$  has the following value:

$$EBS_H = cpb\_size_H$$

where  $cpb\_size_H$  is the  $cpb\_size$  for the SVC video sub-bitstream in elementary stream  $ES_H$  as defined in 2.14.3.1 for the re-assembled AVC video stream.

- There is exactly one dependency representation buffer  $DRB_n$  for each elementary stream in the set of received elementary streams as shown in Figure 2-15, where each dependency representation buffer  $DRB_n$  in the set of received elementary streams is allocated within  $EB_H$ . Even though the size  $DRBS_n$  of individual  $DRB_n$  is not constrained, the sum of the sizes  $DRBS_n$  is constrained as follows:

$$EBS_H = \sum_n (DRBS_n)$$

- Transfer from  $TB_n$  to  $MB_n$  is applied as follows:

When there is no data in  $TB_n$  then  $Rx_n$  is equal to zero. Otherwise:

$$Rx_n = bit\_rate$$

where  $bit\_rate$  is  $1.2 \times BitRate[ SchedSelIdx ]$  of data flow into the CPB for the byte stream format and  $BitRate[ SchedSelIdx ]$  is as defined in Annex E of Rec. ITU-T H.264 | ISO/IEC 14496-10 when  $NAL\_hrd\_parameters()$  is present in the VUI parameters of the SVC video sub-bitstream.

NOTE 2 – Annex E also specifies default values for  $BitRate[ SchedSelIdx ]$  based on profile and level when  $NAL\_HRD$  parameters are not present in the VUI. The SVC video sub-bitstream level is determined by the level of AVC video stream resulting from re-assembling (up to) the associated video sub-bitstream  $n$  in elementary stream  $ES_n$ .

- Transfer from  $MB_n$  to  $DRB_n$  is applied as follows:

If the  $AVC\_timing\_and\_HRD\_descriptor$  is present with the  $hrd\_management\_valid\_flag$  set to '1' for elementary stream  $ES_H$ , then the transfer of data from  $MB_n$  to  $DRB_n$  shall follow the HRD defined scheme for data arrival in the CPB of elementary stream  $ES_H$  as defined in Annex C of Rec. ITU-T H.264 | ISO/IEC 14496-10.

Otherwise, the leak method shall be used to transfer data from  $MB_n$  to  $DRB_n$  as follows:

Rate  $Rbx_n$ :

$$Rbx_n = 1200 \times MaxBR[level]_n$$

where  $MaxBR[level]_n$  is defined for the byte stream format in Table A.1 (Level Limits) in Rec. ITU-T H.264 | ISO/IEC 14496-10 for the level of the AVC video stream resulting from re-assembling (up to) the associated video sub-bitstream  $n$  in elementary stream  $ES_n$ . If there is PES packet payload data in  $MB_n$ , and buffer  $EB_H$  is not full, the PES packet payload is transferred from  $MB_n$  to  $DRB_n$  at a rate equal to  $Rbx_n$ . If  $EB_H$  is full, data are not removed from  $MB_n$ . When a byte of data is transferred from  $MB_n$  to  $DRB_n$ , all PES packet header bytes that are in  $MB_n$  and precede that byte are instantaneously removed and discarded. When there is no PES packet payload data present in  $MB_n$ , no data is removed from  $MB_n$ . All data that enters  $MB_n$  leaves it. All PES packet payload data bytes enter  $DRB_n$  instantaneously upon leaving  $MB_n$ .

### Access unit re-assembling and EB removal

The following specifies the access unit re-assembling that results in AVC access unit  $A_H(j)$ :

- i) Collect all SVC dependency representations  $DR_n(j_n)$  starting with the highest value of  $dependency\_id$   $n$ , equal to  $H$ , to the lowest value of  $dependency\_id$   $n$ , equal to  $m$ , present in access unit  $A_H(j)$  following the rule below:
  - For each two corresponding  $DR_{y+1}(j_{y+1})$  and  $DR_y(j_y)$  of the SVC dependency representations collected for access unit  $A_H(j)$ , if  $TREF$  field is present for  $DR_{y+1}(j_{y+1})$ , the  $TREF$  value of  $DR_{y+1}(j_{y+1})$  shall be equal to the  $DTS$  value  $td_y(j_y)$  of  $DR_y(j_y)$ , otherwise the  $DTS$  value of  $td_{y+1}(j_{y+1})$  of  $DR_{y+1}(j_{y+1})$  shall be equal to  $DTS$  value  $td_y(j_y)$  of  $DR_y(j_y)$ .
- ii) Assemble the SVC dependency representations in consecutive order of  $dependency\_id$   $n$  starting from 'm' to 'H' for the  $j$ -th access unit  $A_H(j)$ . If SEI NAL units are present in any SVC dependency representation with  $dependency\_id$  not equal to 0, these NAL units shall be re-ordered to the order of NAL units within an access unit as defined in Rec. ITU-T H.264 | ISO/IEC 14496-10 before access unit re-assembling.

NOTE 2 – The number of SVC dependency representations for each access unit  $A_H(j)$  may vary depending on value of  $j$ . If  $m$  represents the lowest value of  $dependency\_id$  for access unit  $A_H(j)$ , then the collected and assembled SVC dependency representations include  $DR_m(j_m)$ ,  $DR_{m+1}(j_{m+1})$ , ...,  $DR_H(j_H)$ .

The following specifies the removal of access unit  $A_H(j)$  from buffer  $EB_H$ :

At time  $td_H(j)$  the AVC access unit  $A_H(j)$  shall be re-assembled and available for removal from buffer  $EB_H$ . The decoding time  $td_H(j)$  is specified by the DTS or by the CPB removal time that is associated with the SVC dependency representations in elementary stream  $ES_H$ , as derived from information in the re-assembled AVC video stream.

**STD delay**

The STD delay for re-assembled AVC access units shall follow the constraints specified in 2.14.3.1.

**Buffer management conditions**

Transport streams shall be constructed so that the following conditions for buffer management are satisfied:

- Each  $TB_n$  shall not overflow and shall be empty at least once every second.
- Each  $MB_n$ ,  $EB_H$ , and  $DPB$  shall not overflow.
- $EB_H$  shall not underflow, except when VUI parameters are present for the AVC video sequence of the re-assembled AVC video stream with the `low_delay_hrd_flag` set to '1'. Underflow of  $EB_H$  occurs for AVC access unit  $A_H(j)$  when one or more bytes of  $A_H(j)$  are not present in  $EB_H$  at the decoding time  $td_H(j)$ .

**2.14.3.6 P-STD extensions for SVC**

The P-STD model described in 2.14.3.2 is applied if the decoded elementary stream is a video sub-bitstream of `stream_type 0x1B`, i.e., only the AVC video sub-bitstream of SVC is decoded.

When there is a set of decoded video sub-bitstreams in a Rec. ITU-T H.222.0 | ISO/IEC 13818-1 program, for which dependencies may be signalled in the `hierarchy_descriptor` as defined in 2.6.6, and when there is at least one of the video sub-bitstreams in the set of decoded elementary streams having the value of `stream_type` equal to `0x1F`, the P-STD model as described in 2.14.3.2 is extended as illustrated in Figure 2-16 and as specified below.

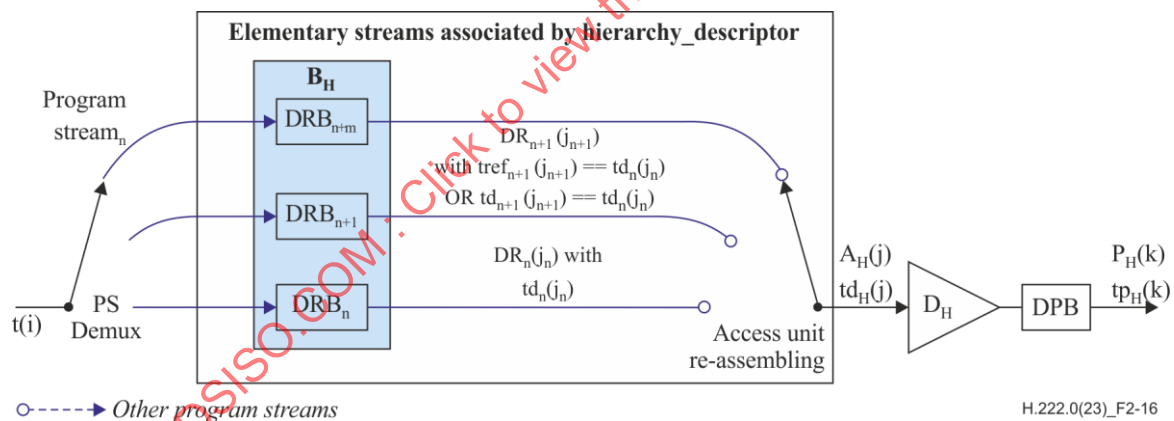

**Figure 2-16 – P-STD model extensions for Rec. ITU-T H.264 | ISO/IEC 14496-10 Video with scalable video sub-bitstreams**

The following additional notations are used to describe the P-STD extensions and are illustrated in Figure 2-16 above.

- $ES_n$  is the decoded elementary stream associated with `dependency_id` value equal to  $n$
- $ES_H$  is the decoded elementary stream associated with the highest value  $H$  of `dependency_id` in the set of decoded elementary streams
- $j$  is an index to the re-assembled access units
- $j_n$  is an index to the SVC dependency representations of the elementary stream associated with `dependency_id` value equal to  $n$
- $DR_n(j_n)$  is the  $j_n$ -th SVC dependency representation of video sub-bitstream associated with `dependency_id` value equal to  $n$

- $A_H(j)$  is the  $j$ -th access unit resulting from re-assembling (up to) the  $j_H$ -th SVC dependency representations with `dependency_id` value equal to  $H$
- $td_n(j_n)$  is the decoding time, measured in seconds, in the system target decoder of the  $j_n$ -th SVC dependency representation of the video sub-bitstream associated with `dependency_id` value equal to  $n$
- $td_H(j)$  is the decoding time, measured in seconds, in the system target decoder of the  $j$ -th access unit  $A_H(j)$  resulting from re-assembling (up to) the  $j_H$ -th SVC dependency representations  $DR_H(j_H)$
- $tref_n(j_n)$  is equal to the decoding time value  $td_{n-1}(j_{n-1})$  associated with the  $j_{n-1}$ -th SVC dependency representation  $DR_{n-1}(j_{n-1})$ , indicated by the TREF field of the PES header of the  $j_n$ -th SVC dependency representation  $DR_n(j_n)$  of the same access unit
- $B_H$  is the input buffer for all decoded video sub-bitstreams
- $BS_H$  is the size of the input buffer  $B_H$ , measured in bytes
- $DRB_n$  is the dependency representation buffer for elementary stream  $ES_n$
- $DRBS_n$  is the size of dependency representation buffer  $DRB_n$ , measured in bytes

### Carriage in PES packets

For correct re-assembling of the SVC dependency representations to an AVC access unit, if there is both an SVC dependency representation with any `dependency_id` equal to  $n$  and an SVC dependency representation with `dependency_id` equal to  $(n+1)$  in the same AVC access unit, the following applies:

- a PES packet per SVC dependency representation start shall be present, i.e., at most one SVC dependency representation may commence in the same PES packet;
- the PTS and, if applicable, the DTS value shall be provided in the PES header of each SVC dependency representation;
- if the DTS value of the SVC dependency representation with `dependency_id` equal to  $n$  is different from the DTS value of the SVC dependency representation with `dependency_id` equal to  $(n+1)$  of the same access unit, the TREF field as defined in 2.4.3.7 shall be present in the PES header extension of the SVC dependency representation with `dependency_id` equal to  $(n+1)$  and the TREF value shall be equal to the DTS value of the SVC dependency representation with `dependency_id` equal to  $n$ .

### DPB buffer management

The DPB buffer management for the re-assembled AVC video stream shall conform to 2.14.3.1 using AVC access unit timing values, as DTS or CPB removal time, and PTS or DPB removal time, associated with the SVC dependency representations of the video sub-bitstream in elementary stream  $ES_H$ .

### $B_n$ buffer management

The following applies:

- There is exactly one elementary stream buffer  $B_H$  for all the elementary streams in the set of decoded elementary streams as shown in Figure 2-16, where the size of  $BS_H$  is defined by the `P-STD_buffer_size` field in the PES packet header of elementary stream  $ES_H$ .
- There is exactly one dependency representation buffer  $DRB_n$  for each elementary stream in the set of decoded elementary streams as shown in Figure 2-16, where each dependency representation buffer  $DRB_n$  in the set of decoded elementary streams is allocated within  $BS_H$ . Even though the size  $DRBS_n$  of individual  $DRB_n$  is not constrained, the sum of the sizes  $DRBS_n$  is constrained as follows:

$$BS_H = \sum_n (DRBS_n)$$

where  $BS_H$  is the size of the input buffer for the SVC video sub-bitstream in elementary stream  $ES_H$  as defined in 2.14.3.2 for the re-assembled AVC video stream.

### Access unit re-assembling and B removal

The following specifies the access unit re-assembling that results in AVC access unit  $A_H(j)$ :

- Collect all SVC dependency representations  $DR_n(j_n)$  starting with the highest value of `dependency_id`  $n$ , equal to  $H$ , to the lowest value of `dependency_id`  $n$ , equal to  $m$ , present in access unit  $A_H(j)$  following the rule below:
  - For each two corresponding  $DR_{y+1}(j_{y+1})$  and  $DR_y(j_y)$  of the SVC dependency representations collected for access unit  $A_H(j)$ , if TREF field is present for  $DR_{y+1}(j_{y+1})$ , the TREF value of  $DR_{y+1}(j_{y+1})$   $tref_{y+1}(j_{y+1})$

shall be equal to the DTS value  $td_y(j_y)$  of  $DR_y(j_y)$ , otherwise the DTS value of  $td_{y+1}(j_{y+1})$  of  $DR_{y+1}(j_{y+1})$  shall be equal to DTS value  $td_y(j_y)$  of  $DR_y(j_y)$ .

- ii) Assemble the SVC dependency representations in consecutive order of dependency\_id n starting from 'm' to 'H' for the j-th access unit  $A_H(j)$ . If SEI NAL units are present in any SVC dependency representation with dependency\_id not equal to 0, these NAL units shall be re-ordered to the order of NAL units within an access unit as defined in Rec. ITU-T H.264 | ISO/IEC 14496-10 before access unit re-assembling.

NOTE – The number of SVC dependency representations for each access unit  $A_H(j)$  may vary depending on value of j. If m represents the lowest value of dependency\_id for access unit  $A_H(j)$ , then the collected and assembled SVC dependency representations include  $DR_m(j_m)$ ,  $DR_{m+1}(j_{m+1})$ , ...,  $DR_H(j_H)$ .

The following specifies the removal of access unit  $A_H(j)$  from buffer  $B_H$ :

At time  $td_H(j_H)$  the AVC access unit  $A_H(j_H)$  shall be re-assembled and available for removal from buffer  $B_H$ . The decoding time  $td_H(j)$  is specified by the DTS or by the CPB removal time that is associated with the SVC dependency representations in elementary stream  $ES_H$ , as derived from information in the re-assembled AVC video stream.

**STD delay**

The STD delay for the re-assembled AVC access units shall follow the constraints specified in 2.14.3.2.

**Buffer management conditions**

Program streams shall be constructed so that the following conditions for buffer management are satisfied:

- $B_H$  shall not overflow.
- $B_H$  shall not underflow, except when VUI parameters are present for the AVC video sequence of the re-assembled AVC video stream with the low\_delay\_hrd\_flag set to '1' or when trick\_mode status is true. Underflow of  $B_H$  occurs for AVC access unit  $A_H(j)$  when one or more bytes of  $A_H(j)$  are not present in  $B_H$  at the decoding time  $td_H(j)$ .

**2.14.3.7 T-STD extensions for MVC and MVCD**

The T-STD model described in 2.14.3.1 is applied if the received elementary stream is a video sub-bitstream of stream\_type 0x1B, i.e., only the AVC video sub-bitstream of MVC or MVC base view sub-bitstream is received and decoded.

When there is a set of received video sub-bitstreams and MVC video sub-bitstreams in a Rec. ITU-T H.222.0 | ISO/IEC 13818-1 program, of which dependencies may be signalled in the hierarchy descriptor, as defined in 2.6.7, and when there is at least one of the MVC video sub-bitstreams in the set of received elementary streams having the value of stream\_type equal to 0x20, the T-STD model as described in 2.14.3.1 is extended as illustrated in Figure 2-17 and as specified below.

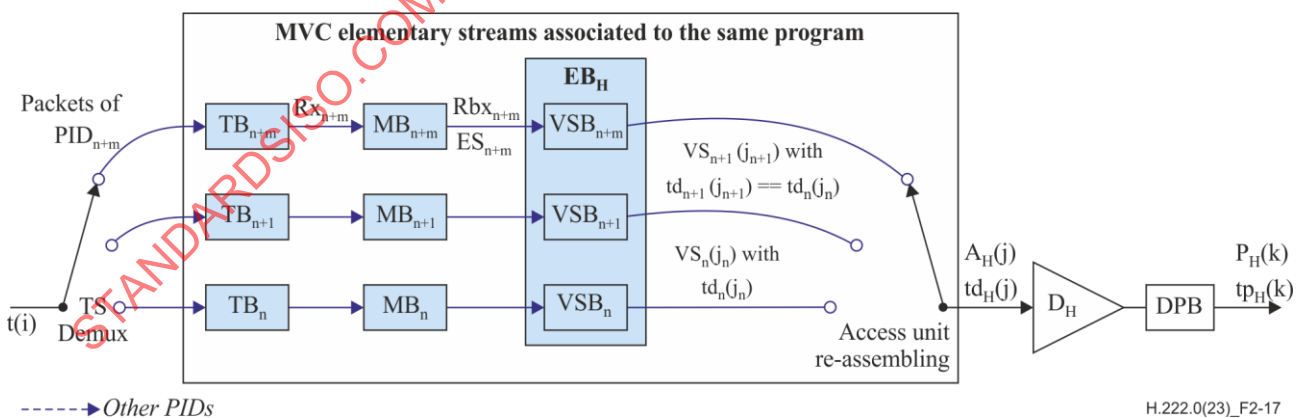

**Figure 2-17 – T-STD model extensions for Rec. ITU-T H.264 | ISO/IEC 14496-10 Video with MVC video sub-bitstreams**

The following additional notations are used to describe the T-STD extensions and are illustrated in Figure 2-17.

$ES_n$  is the received elementary stream associated with the n-th MVC video sub-bitstream, where n is the index to the MVC view\_id subsets starting with value 0 for the MVC view\_id subset containing the

	base view and ordered according to the minimum view order index contained in each MVC video sub-bitstream
$ES_H$	is the received elementary stream associated with the H-th MVC video sub-bitstream which includes the view components with the highest view order index present in all MVC video sub-bitstreams of received elementary streams
$j$	is an index to the re-assembled access units
$j_n$	is an index to the MVC view-component subsets of the elementary stream $ES_n$ associated with the n-th MVC video sub-bitstream
$VS_n(j_n)$	is the $j_n$ -th MVC view-component subset of the MVC video sub-bitstream associated with $ES_n$
$A_H(j)$	is the j-th access unit resulting from re-assembling (up to) the H-th MVC view-component subset associated with $ES_H$
$td_n(j_n)$	is the decoding time, measured in seconds, in the system target decoder of the MVC view-component subset $VS_n(j_n)$
$td_H(j)$	is the decoding time, measured in seconds, in the system target decoder of the j-th access unit $A_H(j)$ resulting from re-assembling (up to) the MVC view-component subset $VS_H(j_H)$
$TB_n$	is the transport buffer for elementary stream $ES_n$
$TBS_n$	is the size of the transport buffer $TB_n$ , measured in bytes
$MB_n$	is the multiplexing buffer for elementary stream $ES_n$
$MBS_n$	is the size of the multiplexing buffer $MB_n$ , measured in bytes
$VSB_n$	is the view component subset buffer for elementary stream $ES_n$
$VSBS_n$	is the size of view component subset buffer $VSBS_n$ , measured in bytes
$EB_H$	is the elementary stream buffer for the AVC video sub-bitstream of MVC and all MVC video sub-bitstreams
$EBS_H$	is the size of elementary stream buffer $EB_H$ , measured in bytes
$R_{x_n}$	transfer rate from $TB_n$ to $MB_n$ , as specified below
$R_{b_n}$	transfer rate from $MB_n$ to $VSBS_n$ , as specified below

### Carriage in PES packets

For correct re-assembling of the MVC view-component subsets to an AVC access unit, the following applies:

- a PES packet per MVC view-component subset start shall be present, i.e., at most one MVC view-component subset may commence in the same PES packet;
- the PTS and, if applicable, the DTS value shall be provided in the PES header of each MVC view-component subset.

### DPB buffer management

The DPB buffer management for the re-assembled AVC video stream shall conform to 2.14.3.1 using AVC access unit timing values, as DTS or CPB removal time, and PTS or DPB removal time, associated with the MVC view-component subsets of the MVC video sub-bitstream in elementary stream  $ES_H$ .

### $TB_n$ , $MB_n$ , $EB_n$ buffer management

The following applies:

- There is exactly one transport buffer  $TB$ , as defined in 2.14.3.1, for each received elementary stream in the set of received MVC video sub-bitstreams, including AVC video sub-bitstream of MVC, contained in elementary streams as shown in Figure 2-17.
- There is exactly one multiplexing buffer  $MB_0$  for the AVC video sub-bitstream of MVC in elementary stream  $ES_0$ , where the size of the multiplexing buffer  $MBS_0$  is constrained as follows:

$$MBS_0 = BS_{\text{mux},0} + BS_{\text{oh},0} + 1200 \times \text{MaxCPB}[\text{level}]_0 - \text{cpb\_size}_0$$

where  $BS_{\text{mux},0}$ ,  $BS_{\text{oh},0}$  are defined in 2.14.3.1 for the AVC video sub-bitstream of MVC in elementary stream  $ES_0$ .

where  $\text{MaxCPB}[\text{level}]_0$  and  $\text{cpb\_size}_0$  for the elementary stream  $ES_0$  are defined, as in 2.14.3.1.

NOTE 1 – If HRD parameters are present in at least one of the MVC video sub-bitstreams, those parameters have to be carefully handled in order to not unnecessarily increase the multiplexing buffers allocation.

- There is exactly one multiplexing buffer  $MB_n$  for each received elementary stream associated with view order index value not equal to 0, where the size of each multiplexing buffer  $MBS_n$  in the set of received elementary streams is constrained as follows:

$$MBS_n = BS_{mux,n} + BS_{oh,n}$$

where  $BS_{mux,n}$ ,  $BS_{oh,n}$  are defined in 2.14.3.1 for the AVC video stream resulting from re-assembling (up to) the MVC video sub-bitstream in elementary stream  $ES_n$ .

- There is exactly one elementary stream buffer  $EB_H$  for all the elementary streams in the set of received elementary streams as shown in Figure 2-17, of which the size  $EBS_H$  has the following value:

$$EBS_H = cpb\_size_H$$

where  $cpb\_size_H$  is the  $cpb\_size$  for the MVC video sub-bitstream in elementary stream  $ES_H$  as defined in 2.14.3.1 for the re-assembled AVC video stream.

- There is exactly one view component subset buffer  $VSBS_n$  for each elementary stream in the set of received elementary streams as shown in Figure 2-17, where each view component subset buffer  $VSBS_n$  in the set of received elementary streams is allocated within  $EB_H$ . Even though the size  $VSBS_n$  of individual  $VSBS_n$  is not constrained, the sum of the sizes  $VSBS_n$  is constrained as follows:

$$EBS_H = \sum_n (VSBS_n)$$

- Transfer from  $TB_n$  to  $MB_n$  is applied as follows:

Rate  $Rx_n$ :

when there is no data in  $TB_n$ , then  $Rx_n$  is equal to zero.

Otherwise:  $Rx_n = bit\_rate$

where  $bit\_rate$  is  $1.2 \times BitRate[ SchedSelIdx ]$  of data flow into the CPB for the byte stream format and  $BitRate[ SchedSelIdx ]$  is as defined in Annex E of Rec. ITU-T H.264 | ISO/IEC 14496-10 when  $NAL\_hrd\_parameters()$  is present in the VUI parameters of the MVC video sub-bitstream.

NOTE 2 – Annex E also specifies default values for  $BitRate[ SchedSelIdx ]$  based on profile and level when  $NAL\_HRD$  parameters are not present in the VUI. The MVC video sub-bitstream level is determined by the level of AVC video stream resulting from re-assembling (up to) the associated MVC video sub-bitstream  $n$  in elementary stream  $ES_n$ .

- Transfer from  $MB_n$  to  $VSBS_n$  is applied as follows:

If the AVC\_timing\_and\_HRD\_descriptor is present with the hrd\_management\_valid\_flag set to '1' for elementary stream  $ES_H$ , then the transfer of data from  $MB_n$  to  $VSBS_n$  shall follow the HRD defined scheme for data arrival in the CPB of elementary stream  $ES_H$  as defined in Annex C of Rec. ITU-T H.264 | ISO/IEC 14496-10.

Otherwise, the leak method shall be used to transfer data from  $MB_n$  to  $VSBS_n$  as follows:

Rate  $Rbx_n$ :

$$Rbx_n = 1200 \times MaxBR[level]_n$$

where  $MaxBR[level]_n$  is defined for the byte stream format in Table A.1 (Level limits) in Rec. ITU-T H.264 | ISO/IEC 14496-10 for the level of the AVC video stream resulting from re-assembling (up to) the associated MVC video sub-bitstream  $n$  in elementary stream  $ES_n$ . If there is PES packet payload data in  $MB_n$ , and buffer  $EB_H$  is not full, the PES packet payload is transferred from  $MB_n$  to  $VSBS_n$  at a rate equal to  $Rbx_n$ . If  $EB_H$  is full, data are not removed from  $MB_n$ . When a byte of data is transferred from  $MB_n$  to  $VSBS_n$ , all PES packet header bytes that are in  $MB_n$  and precede that byte are instantaneously removed and discarded. When there is no PES packet payload data present in  $MB_n$ , no data is removed from  $MB_n$ . All data that enters  $MB_n$  leaves it. All PES packet payload data bytes enter  $VSBS_n$  instantaneously upon leaving  $MB_n$ .

#### Access unit re-assembling and EB removal

The following specifies the access unit re-assembling that results in AVC access unit  $A_H(j)$ :

- Assemble the MVC view-component subsets for the  $j$ -th access unit  $A_H(j)$  following the rule below:

- For each two corresponding MVC view-component subsets  $VS_{y+1}(j_{y+1})$  and  $VS_y(j_y)$  collected for access unit  $A_H(j)$ , where  $VS_y$  is associated with a program element identified by the `hierarchy_layer_index` indicated in the associated hierarchy descriptor, and  $VS_{y+1}$  indicates the `hierarchy_layer_index` of  $VS_y$  as the `hierarchy_embedded_layer_index` in the hierarchy descriptor associated with program element associated with  $VS_{y+1}$ , the DTS value of  $td_{y+1}(j_{y+1})$  of  $VS_{y+1}(j_{y+1})$  shall be equal to DTS value  $td_y(j_y)$  of  $VS_y(j_y)$ .

NOTE 3 – If no hierarchy descriptor is present,  $VS_y$  is associated with the AVC sub-bitstream and  $VS_{y+1}$  is associated with the MVC sub-bitstream.

- ii) If SEI NAL units are present in any MVC view-component subset with view order index not equal to 0, these NAL units shall be re-ordered to the order of NAL units within an access unit, as defined in Rec. ITU-T H.264 | ISO/IEC 14496-10, before access unit re-assembling.

The following specifies the removal of access unit  $A_H(j)$  from buffer  $EB_H$ :

At the decoding time  $td_H(j)$ , the AVC access unit  $A_H(j)$  shall be re-assembled and available for removal from buffer  $EB_H$ . The decoding time  $td_H(j)$  is specified by the DTS or by the CPB removal time that is associated with the MVC view-component subsets in elementary stream  $ES_H$ , as derived from information in the re-assembled AVC video stream.

### STD delay

The STD delay for re-assembled AVC access units shall follow the constraints specified in 2.14.3.1.

### Buffer management conditions

Transport streams shall be constructed so that the following conditions for buffer management are satisfied:

- Each  $TB_n$  shall not overflow and shall be empty at least once every second.
- Each  $MB_n$ ,  $EB_H$ , and DPB shall not overflow.
- $EB_H$  shall not underflow, except when VUI parameters are present for the AVC video sequence of the re-assembled AVC video stream with the `low_delay_hrd_flag` set to '1'. Underflow of  $EB_H$  occurs for AVC access unit  $A_H(j)$  when one or more bytes of  $A_H(j)$  are not present in  $EB_H$  at the decoding time  $td_H(j)$ .

Buffer management for MVCD video sub-bitstream follows the same extensions as specified for MVC video in this clause. Carriage in PES packets for MVCD video sub-bitstream is specified below:

### Carriage of MVCD sub-bitstream in PES packets

For correct re-assembling of the MVCD view-component subsets to an AVC access unit, the following applies:

- a PES packet per MVCD view-component subset start shall be present, i.e., at most one MVCD view-component subset may commence in the same PES packet;
- the PTS and, if applicable, the DTS value shall be provided in the PES header of each MVCD view-component subset.

### 2.14.3.8 P-STD extensions for MVC

The P-STD model described in 2.14.3.2 is applied if the decoded elementary stream is a video sub-bitstream of `stream_type` 0x1B, i.e., only the AVC video sub-bitstream of MVC or MVC base view sub-bitstream is decoded.

When there is a set of decoded MVC video sub-bitstreams in a Rec. ITU-T H.222.0 | ISO/IEC 13818-1 program, of which view order index values may be signalled in the `MVC_extension_descriptor`, as defined in 2.6.78, and when there is at least one of the MVC video sub-bitstreams in the set of decoded elementary streams having the value of `stream_type` equal to 0x20, the P-STD model, as described in 2.14.3.2, is extended as illustrated in Figure 2-18 and as specified below.

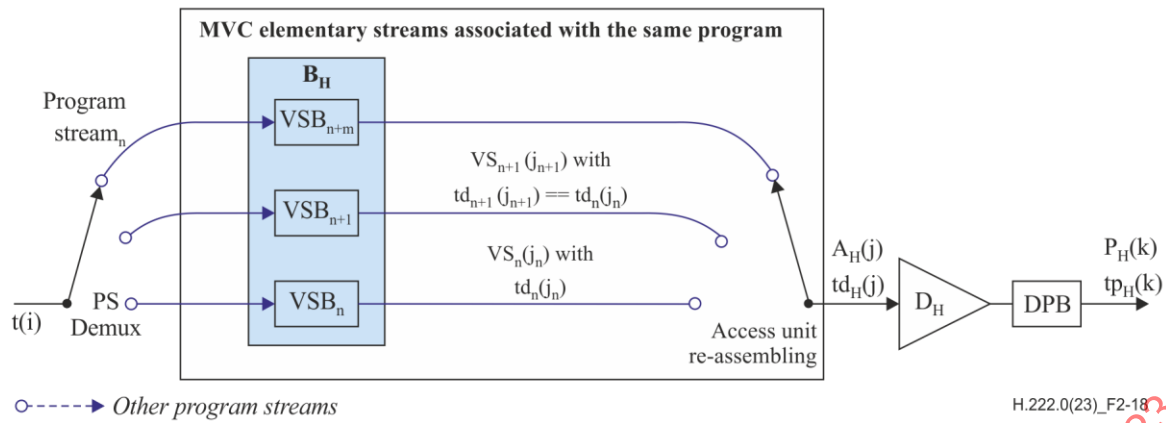

**Figure 2-18 – P-STD model extensions for Rec. ITU-T H.264 | ISO/IEC 14496-10 Video with MVC video sub-bitstreams**

The following additional notations are used to describe the P-STD extensions and are illustrated in Figure 2-18 above.

- $ES_n$  is the received elementary stream associated with the  $n$ -th MVC video sub-bitstream, where  $n$  is the index to the MVC view\_id subsets starting with value 0 for the MVC view\_id subset containing the base view and ordered according to the minimum view order index contained in each MVC view\_id subset
- $ES_H$  is the received elementary stream associated with the  $H$ -th MVC video sub-bitstream which includes the view components with the highest view order index present in all MVC view\_id subsets of received elementary streams
- $j$  is an index to the re-assembled access units
- $j_n$  is an index to the MVC view-component subsets of the elementary stream associated with the  $n$ -th MVC view\_id subset
- $VS_n(j_n)$  is the  $j_n$ -th MVC view-component subset of the MVC video sub-bitstream associated with  $ES_n$
- $A_H(j)$  is the  $j$ -th access unit resulting from re-assembling (up to) the  $H$ -th MVC view-component subset associated with  $ES_H$
- $td_n(j_n)$  is the decoding time, measured in seconds, in the system target decoder of the MVC view-component subset  $VS_n(j_n)$
- $td_H(j)$  is the decoding time, measured in seconds, in the system target decoder of the  $j$ -th access unit  $A_H(j)$  resulting from re-assembling (up to) the MVC view-component subset  $VS_H(j_H)$
- $B_H$  is the input buffer for all decoded MVC video sub-bitstreams
- $BS_H$  is the size of the input buffer  $B_H$ , measured in bytes
- $VSB_n$  is the view component subset buffer for elementary stream  $ES_n$
- $VSBS_n$  is the size of view component subset buffer  $VSB_n$ , measured in bytes

### Carriage in PES packets

For correct re-assembling of the MVC view-component subsets to an AVC access unit, the following applies:

- a PES packet per MVC view-component subset start shall be present, i.e., at most one MVC view-component subset may commence in the same PES packet;
- the PTS and, if applicable, the DTS value shall be provided in the PES header of each MVC view-component subset.

### DPB buffer management

The DPB buffer management for the re-assembled AVC video stream shall conform to 2.14.3.1 using AVC access unit timing values, as DTS or CPB removal time, and PTS or DPB removal time, associated with the MVC view-component subsets of the MVC video sub-bitstream in elementary stream  $ES_H$ .

**B<sub>n</sub> buffer management**

The following applies:

- There is exactly one elementary stream buffer B<sub>H</sub> for all the elementary streams in the set of decoded elementary streams as shown in Figure 2-18, where the size of BS<sub>H</sub> is defined by the P-STD\_buffer\_size field in the PES packet header of elementary stream ES<sub>H</sub>.
- There is exactly one view component subset buffer VSB<sub>n</sub> for each elementary stream in the set of decoded elementary streams as shown in Figure 2-18, where each view component subset buffer VSB<sub>n</sub> in the set of decoded elementary streams is allocated within BS<sub>H</sub>. Even though the size VSBS<sub>n</sub> of individual VSB<sub>n</sub> is not constrained, the sum of the sizes VSBS<sub>n</sub> is constrained as follows:

$$BS_H = \sum_n (VSBS_n)$$

where BS<sub>H</sub> is the size of the input buffer for the MVC video sub-bitstream in elementary stream ES<sub>H</sub>, as defined in 2.14.3.2, for the re-assembled AVC video stream.

**Access unit re-assembling and B removal**

The following specifies the access unit re-assembling that results in AVC access unit A<sub>H</sub>(j):

- Assemble the MVC view-component subsets for the j-th access unit A<sub>H</sub>(j) following the rule below:
  - For each two corresponding MVC view-component subsets VS<sub>y+1</sub>(j<sub>y+1</sub>) and VS<sub>y</sub>(j<sub>y</sub>) collected for access unit A<sub>H</sub>(j), where VS<sub>y</sub> is associated with a program element identified by the hierarchy\_layer\_index indicated in the associated hierarchy descriptor, and VS<sub>y+1</sub> references VS<sub>y</sub> by the hierarchy\_embedded\_layer\_index indicated in the hierarchy\_descriptor associated with program element associated with VS<sub>y+1</sub>, the DTS value of td<sub>y+1</sub>(j<sub>y+1</sub>) of VS<sub>y+1</sub>(j<sub>y+1</sub>) shall be equal to DTS value td<sub>y</sub>(j<sub>y</sub>) of VS<sub>y</sub>(j<sub>y</sub>).
 

NOTE – If no hierarchy descriptor is present, VS<sub>y</sub> is associated with the AVC sub-bitstream and VS<sub>y+1</sub> is associated with the MVC sub-bitstream.
- If SEI NAL units are present in any MVC view-component subset with view order index not equal to 0, these NAL units shall be re-ordered to the order of NAL units within an access unit, as defined in Rec. ITU-T H.264 | ISO/IEC 14496-10, before access unit re-assembling.

The following specifies the removal of access unit A<sub>H</sub>(j) from buffer B<sub>H</sub>:

At the decoding time td<sub>H</sub>(j<sub>H</sub>), the AVC access unit A<sub>H</sub>(j<sub>H</sub>) shall be re-assembled and available for removal from buffer B<sub>H</sub>. The decoding time td<sub>H</sub>(j) is specified by the DTS or by the CPB removal time that is associated with the MVC view-component subsets in elementary stream ES<sub>H</sub>, as derived from information in the re-assembled AVC video stream.

**STD delay**

The STD delay for the re-assembled AVC access units shall follow the constraints specified in 2.14.3.2.

**Buffer management conditions**

Program streams shall be constructed so that the following conditions for buffer management are satisfied:

- B<sub>H</sub> shall not overflow.
- B<sub>H</sub> shall not underflow, except when VUI parameters are present for the AVC video sequence of the re-assembled AVC video stream with the low\_delay\_hrd\_flag set to '1', or when trick\_mode status is true. Underflow of B<sub>H</sub> occurs for AVC access unit A<sub>H</sub>(j) when one or more bytes of A<sub>H</sub>(j) are not present in B<sub>H</sub> at the decoding time td<sub>H</sub>(j).

**2.15 Carriage of ISO/IEC 14496-17 text streams****2.15.1 Introduction**

This subclause defines the carriage of ISO/IEC 14496-17 elementary text streams within Rec. ITU-T H.222.0 | ISO/IEC 13818-1 systems, both for program and transport streams. Typically, an ISO/IEC 14496-17 text stream will be an element of an ISO/IEC 13818-1 program, as defined by the PMT in a transport stream and the PSM in a program stream. The carriage and buffer management of ISO/IEC 14496-17 text streams is defined using existing parameters from Rec. ITU-T H.222.0 | ISO/IEC 13818-1 such as PTS and DTS, as well as information from the ISO/IEC 14496-17 text stream. For this purpose, 2.15.3 specifies the decoding of ISO/IEC 14496-17 streams within the T-STD and P-STD models, using the Hypothetical Text Decoder (HTD) defined in ISO/IEC 14496-17.

When an ISO/IEC 14496-17 text stream is carried in a Rec. ITU-T H.222.0 | ISO/IEC 13818-1 stream, the ISO/IEC 14496-17 coded data shall be contained in PES packets, as defined in 2.15.2. Information needed to decode the ISO/IEC 14496-17 text stream is provided by the MPEG-4 text descriptor, specified in 2.6.70.

Applications that wish to transmit font streams as specified in ISO/IEC 14496-18, can reference the streamed fonts as specified in Annex A.1 of ISO/IEC 14496-17. To transmit ISO/IEC 14496-18 font streams, applications can use the data or object carousel as defined in ISO/IEC 13818-6.

### 2.15.2 Carriage in PES packets

ISO/IEC 14496-17 text streams are carried in PES packets, using one of the assigned 14 `stream_id_extension` values. If the `textFormat` field in `TextConfig()` is coded with the value 0x01, indicating Timed Text as specified in 3GPP TS 26.245, then the text stream consists of a concatenation of 3GPP Text Access Units in display order, whereby each Text Access Unit consists of one or more so-called TTUs. For carriage in PES packets, alignment between PES packets and TTUs is required; i.e., the first byte in the payload of a PES packet carrying an ISO/IEC 14496-17 text stream shall be the first byte of a TTU, which is the first byte of the TTU header specified in 7.4.2 in ISO/IEC 14496-17. There is no further need for alignment; hence, the first TTU in a PES packet may contain for example a non-first fragment of a Text Access unit or a Sample Description.

A PTS shall be coded in the PES packet header of each PES packet carrying an ISO/IEC 14496-17 text stream. The PTS shall refer to the first Text Access Unit that commences in the PES packet. A Text Access Unit commences in a PES packet if a TTU[1] with a complete text sample or the TTU[2] with the first fragment of a text sample is present in the PES packet. For identifying whether a TTU[2] carries the first or a subsequent text sample fragment, see 7.3.2.2 and 7.4.5 in ISO/IEC 14496-17.

### 2.15.3 STD extensions

#### 2.15.3.1 T-STD extensions

The T-STD model includes a transport buffer  $TB_n$  and a multiplex buffer  $B_n$  prior to the Hypothetical Text Decoder defined in ISO/IEC 14496-17. Transport stream packets with ISO/IEC 14496-17 data, as indicated by its PID, enter the buffer  $TB_n$ . Bytes are removed from  $TB_n$  to enter Buffer  $B_n$  at the rate  $R_{X_n}$ . Delivery of bytes from  $B_n$  to enter the TTU Decoder in the HTD is at rate  $R_{b_{X_n}}$ . See also Figure 2-19.

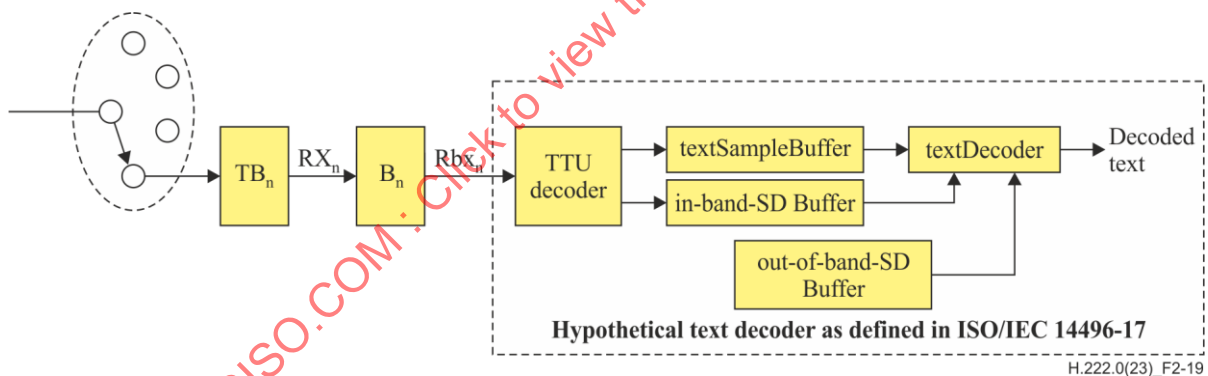

Figure 2-19 – T-STD model extensions for ISO/IEC 14496-17 text streams

#### Buffer management

The size  $TBS_n$  of  $TB_n$  is equal to 512 bytes. For ISO/IEC 14496-17 text streams, the size  $BS_n$  of  $B_n$  is equal to 4096 bytes. The rate  $R_{X_n}$  is equal to 2 000 000 bits/s. The rate  $R_{b_{X_n}}$  meets the delivery schedule defined for ISO/IEC 14496-17 data at the input of the HTD in clause 7.7 of ISO/IEC 14496-17, i.e.,  $R_{b_{X_n}} = R[\text{profile, level}]$  if the `textSampleBuffer` is not full and  $R_{b_{X_n}} = 0$  if the `textSampleBuffer` is full, where  $R[\text{profile, level}]$  is defined as the profile and level specific rate  $R$  in clause 7.8 of ISO/IEC 14496-17.

Each of the following requirements shall apply:

- Buffer  $TB_n$  shall not overflow.
- Buffer  $B_n$  shall not overflow.
- Each HTD requirement specified in clause 7.7 of ISO/IEC 14496-17 shall be met.

### 2.15.3.2 P-STD extensions

The P-STD model for the decoding of an ISO/IEC 14496-17 text stream includes a multiplex buffer  $B_n$  prior to the Hypothetical Text Decoder defined in ISO/IEC 14496-17. For each ISO/IEC 14496-17 text stream  $n$ , the size  $BS_n$  of buffer  $B_n$  in the P-STD is defined by the P-STD\_buffer\_size field in the PES packet header.

Each of the following requirements shall apply:

- Buffer  $B_n$  shall not overflow.
- Each HTD requirement specified in clause 7.7 of ISO/IEC 14496-17 shall be met.

## 2.16 Carriage of auxiliary video streams

ISO/IEC 23002-3 specifies auxiliary video streams. ISO/IEC 23002-3 auxiliary video streams can be carried over Rec. ITU-T H.222.0 | ISO/IEC 13818-1 streams as follows:

- in Table 2-27, 16 stream-id\_extension values are assigned to signal auxiliary video streams;
- in Table 2-34, one stream-type value is assigned to signal an auxiliary video stream;
- in Table 2-45, one descriptor tag is assigned to indicate an auxiliary video stream descriptor;
- in 2.6.74 the auxiliary video stream descriptor is specified;
- the auxiliary video stream descriptor is associated with each auxiliary video stream.

Auxiliary video streams provide additional information about a conventional primary video sequence, as specified in ISO/IEC 23002-3. The auxiliary video stream shall be synchronized with its primary video counterpart through the use of timestamps in the associated PES header based on the same PCR clock.

In case a program contains multiple video streams, it will be up to the application to specify the association between the video component and auxiliary video streams.

## 2.17 Carriage of HEVC

### 2.17.1 Constraints for the transport of HEVC

For HEVC video streams, HEVC temporal video sub-bitstreams or HEVC temporal video subsets, the following constraints additionally apply:

- Each HEVC access unit shall contain an access unit delimiter NAL unit.  
NOTE 1 – HEVC requires that an access unit delimiter NAL unit, if present, is the first NAL unit within an HEVC access unit. Access unit delimiter NAL units simplify the ability to detect the boundary between HEVC access units.
- An HEVC video stream or HEVC temporal video sub-bitstream of an HEVC video stream conforming to one or more profiles defined in Annex A of Rec. ITU-T H.265 | ISO/IEC 23008-2 shall be an element of a Rec. ITU-T H.222.0 | ISO/IEC 13818-1 program and the stream\_type for this elementary stream shall be equal to 0x24.  
NOTE 2 – Such a stream can be the HEVC base sub-partition of an HEVC video stream conforming to one or more profiles defined in Annex G or Annex H of Rec. ITU-T H.265 | ISO/IEC 23008-2.
- The video parameter sets, sequence parameter sets and picture parameter sets, as specified in Rec. ITU-T H.265 | ISO/IEC 23008-2, that are necessary for decoding an HEVC video stream or HEVC temporal video sub-bitstream shall be present within the elementary stream carrying that HEVC video stream or HEVC temporal video sub-bitstream.
- For each HEVC temporal video subset of an HEVC video stream conforming to one or more profiles defined in Annex A of Rec. ITU-T H.265 | ISO/IEC 23008-2 that is an element of the same Rec. ITU-T H.222.0 | ISO/IEC 13818-1 program, the stream\_type for this elementary stream shall be equal to 0x25.  
NOTE 3 – Such a stream can be an HEVC sub-partition of an HEVC video stream conforming to one or more profiles defined in Annex G or Annex H of Rec. ITU-T H.265 | ISO/IEC 23008-2.
- An HEVC enhancement sub-partition of an HEVC video stream conforming to one or more profiles defined in Annex G or Annex H of Rec. ITU-T H.265 | ISO/IEC 23008-2 shall be an element of an Rec. ITU-T H.222.0 | ISO/IEC 13818-1 program. The stream\_type for this elementary stream shall be set according to Table 2-34.
- The video parameter sets, sequence parameter sets, and picture parameter sets, as specified in Rec. ITU-T H.265 | ISO/IEC 23008-2, necessary for decoding an HEVC video stream, HEVC temporal video sub-bitstream, or HEVC base sub-partition shall be present within the elementary stream carrying that HEVC video stream, HEVC temporal video sub-bitstream, or HEVC base sub-partition.

- When a Rec. ITU-T H.222.0 | ISO/IEC 13818 1 program includes one or more elementary streams with stream\_type equal to 0x28, 0x29, 0x2A or 0x2B, at least one HEVC operation point descriptor shall be present in the program map table associated with the program.
- When a Rec. ITU-T H.222.0 | ISO/IEC 13818 1 program includes more than one elementary stream with the same stream\_type value of 0x24, 0x25 or in the range of 0x28 .. 0x2B and hierarchy cannot be implied as specified in Table 2-137, one hierarchy descriptor as defined in 2.6.7 shall be present for each elementary stream with a stream\_type value of 0x24, 0x25 and one HEVC hierarchy extension descriptor as defined in 2.6.102 shall be present for each elementary stream with a stream\_type value in the range of 0x28 .. 0x2B.
  - NOTE 4 – Hierarchy descriptors or HEVC hierarchy extension descriptors are needed to assign a hierarchy layer index to each elementary stream if hierarchy cannot be implied, as specified in Table 2-137.
- In each elementary stream with stream\_type equal to 0x24 with a hierarchy descriptor, the hierarchy\_type in the hierarchy descriptor shall be equal to 15.
- In each elementary stream with stream\_type equal to 0x25 with a hierarchy descriptor, the hierarchy\_type in the hierarchy descriptor shall be equal to 3.
- The video parameter sets, sequence parameter sets and picture parameter sets, as specified in Rec. ITU-T H.265 | ISO/IEC 23008-2, that are necessary for decoding the HEVC highest temporal sub-layer representation of an HEVC temporal video subset shall be present within the elementary stream carrying the HEVC temporal video sub-bitstream associated by a hierarchy descriptor.
- The aggregation of the HEVC temporal video sub-bitstream with associated HEVC temporal video subsets according to the hierarchy descriptors, as specified in 2.17.3, shall result in a valid HEVC video stream.
  - NOTE 5 – The resulting HEVC video stream contains a set of temporal sub-layers, as specified in Rec. ITU-T H.265 | ISO/IEC 23008-2, with TemporalId values forming a contiguous range of integer numbers.
- The aggregation, as specified in 2.17.4, of an HEVC enhancement sub-partition with all HEVC sub-partitions according to the HEVC operation signalled in the HEVC operation point descriptor shall result in a valid layered HEVC video stream.
  - NOTE 6 – The resulting HEVC video stream is the HEVC operation point of that HEVC enhancement sub-partition.
- Each HEVC picture with nuh\_layer\_id larger than 0 shall be contained within an elementary stream with a stream\_type equal to either 0x28, 0x29, 0x2A or 0x2B.
- An elementary stream ES<sub>te</sub> with stream\_type equal to either 0x29 or 0x2B shall satisfy the following:
  - The elementary stream ES<sub>te</sub> contains an HEVC temporal video subset which is a temporal enhancement for exactly one reference elementary stream ES<sub>ref</sub>, i.e., the layer L<sub>i</sub> present in the reference elementary stream ES<sub>ref</sub> shall also be present in the elementary stream ES<sub>te</sub>.
    - NOTE 7 – The reference elementary stream ES<sub>ref</sub> is either an HEVC temporal video sub-bitstream with a stream\_type equal to either 0x28 or 0x2A or another HEVC temporal video subset with stream\_type equal to either 0x29 or 0x2B, respectively, for which the same applies.

### Carriage in PES packets

Rec. ITU-T H.265 | ISO/IEC 23008-2 video is carried in PES packets as PES\_packet\_data\_bytes, using one of the 16 stream\_id values assigned to video, while signalling the Rec. ITU-T H.265 | ISO/IEC 23008-2 video stream, by means of the assigned stream\_type value in the PMT (see Table 2-34). The highest level that may occur in an HEVC video stream, as well as a profile and tier that the entire stream conforms to should be signalled using the HEVC video descriptor. If an HEVC video descriptor is associated with an HEVC video stream, an HEVC temporal video sub-bitstream, an HEVC temporal video subset or an HEVC enhancement sub-partition, then this descriptor shall be conveyed in the descriptor loop for the respective elementary stream entry in the program map table. This Recommendation | International Standard does not specify the presentation of Rec. ITU-T H.265 | ISO/IEC 23008-2 streams in the context of a program stream.

For PES packetization, no specific data alignment constraints apply. For synchronization and STD management, PTSs and, when appropriate, DTSs are encoded in the header of the PES packet that carries the ITU-T H.265 | ISO/IEC 23008-2 video elementary stream data. For PTS and DTS encoding, the constraints and semantics apply as defined in 2.4.3.7 and 2.7.

### DPB buffer management

Carriage of an HEVC video stream, an HEVC temporal video sub-stream, an HEVC temporal video subset or an HEVC enhancement sub-partition over Rec. ITU-T H.222.0 | ISO/IEC 13818-1 does not impact the size of the buffer DPB. For decoding of an HEVC video stream, an HEVC temporal video sub-bitstream or an HEVC temporal video sub-bitstream and its associated HEVC temporal video subsets in the STD, the size of DPB is as defined in Rec. ITU-T H.265 | ISO/IEC 23008-2. The DPB shall be managed as specified in Annex C of Rec. ITU-T H.265 | ISO/IEC 23008-2

(clauses C.3 and C.5). A decoded HEVC access unit enters the DPB instantaneously upon decoding the HEVC access unit, hence at the CPB removal time of the HEVC access unit. A decoded HEVC access unit is presented at the DPB output time. If the HEVC video stream, HEVC temporal video sub-bitstream or HEVC temporal video subset provides insufficient information to determine the CPB removal time and the DPB output time of HEVC access units, then these time instants shall be determined in the STD model from PTS and DTS timestamps as follows:

- 1) The CPB removal time of HEVC access unit  $n$  is the instant in time indicated by  $DTS(n)$  where  $DTS(n)$  is the DTS value of HEVC access unit  $n$ .
- 2) The DPB output time of HEVC access unit  $n$  is the instant in time indicated by  $PTS(n)$  where  $PTS(n)$  is the PTS value of HEVC access unit  $n$ .

NOTE 8 – HEVC video sequences in which the *low\_delay\_hrd\_flag* in the syntax structure *hrd\_parameters()* is set to 1 carry sufficient information to determine the DPB output time and the CPB removal time of each HEVC access unit. Hence for HEVC access units for which STD underflow may occur, the CPB removal time and the DPB output time are defined by HRD parameters, and not by DTS and PTS timestamps.

NOTE 9 – An HEVC video stream may carry information to determine compliance of the HEVC video stream to the HRD, as specified in Annex C of Rec. ITU-T H.265 | ISO/IEC 23008-2. The presence of this information can be signalled in a transport stream using the HEVC timing and HRD descriptor with the *hrd\_management\_valid\_flag* set to '1'. Irrespective of the presence of this information, compliance of an HEVC video stream to the T-STD ensures that HRD buffer management requirements for the CPB are met when each byte in the HEVC video stream is delivered to and removed from the CPB in the HRD at exactly the same instant in time at which the byte is delivered to and removed from  $EB_n$  in the T-STD.

### 2.17.2 T-STD Extensions for single layer HEVC

When there is an HEVC video stream or HEVC temporal video sub-bitstream in an ITU-T H.222.0 | ISO/IEC 13818-1 program and there is no HEVC temporal video subset associated with this elementary stream of stream\_type 0x24 in the same ITU-T H.222.0 | ISO/IEC 13818-1 program, the T-STD model as described in 2.4.2.1 is extended as illustrated in Figure 2-20 and as specified below.

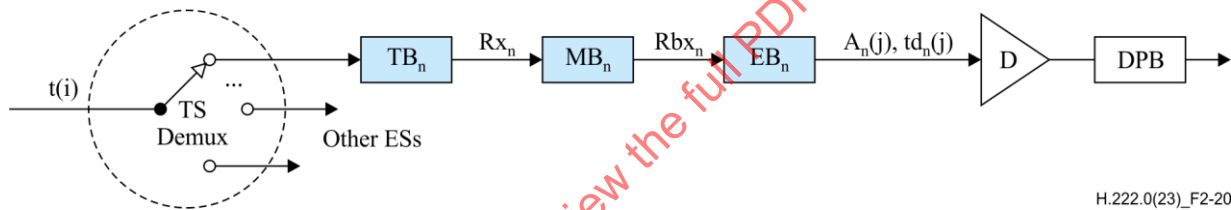

Figure 2-20 – T-STD model extensions for single layer HEVC

#### TB<sub>n</sub>, MB<sub>n</sub>, EB<sub>n</sub> buffer management

The following additional notations are used to describe the T-STD extensions and are illustrated in Figure 2-20.

$t(i)$  indicates the time in seconds at which the  $i$ -th byte of the transport stream enters the system target decoder

$TB_n$  is the transport buffer for elementary stream  $n$

$TBS$  is the size of the transport buffer  $TB_n$ , measured in bytes

$MB_n$  is the multiplexing buffer for elementary stream  $n$

$MBS_n$  is the size of the multiplexing buffer  $MB_n$ , measured in bytes

$EB_n$  is the elementary stream buffer for the HEVC video stream

$j$  is an index to the HEVC access unit of the HEVC video stream

$A_n(j)$  is the  $j$ -th access unit of the HEVC video bitstream

$td_n(j)$  is the decoding time of  $A_n(j)$ , measured in seconds, in the system target decoder

$R_{x_n}$  is the transfer rate from the transport buffer  $TB_n$  to the multiplex buffer  $MB_n$  as specified below.

$R_{b_{x_n}}$  is the transfer rate from the multiplex buffer  $MB_n$  to the elementary stream buffer  $EB_n$  as specified below.

The following apply:

- There is exactly one transport buffer  $TB_n$  for the received HEVC video stream or HEVC temporal video sub-bitstream where the size  $TBS$  is fixed to 512 bytes.
- There is exactly one multiplexing buffer  $MB_n$  for the HEVC video stream or HEVC temporal video sub-bitstream, where the size  $MBS_n$  of the multiplexing buffer  $MB$  is constrained as follows:

$$MBS_n = BS_{mux} + BS_{oh} + CpbNalFactor \times MaxCPB[tier, level] - cpb\_size$$

where  $BS_{oh}$ , packet overhead buffering, is defined as:

$$BS_{oh} = (1/750) \text{ seconds} \times \max\{ BrNalFactor \times MaxBR[tier, level], 2\,000\,000 \text{ bit/s} \}$$

and  $BS_{mux}$ , additional multiplex buffering, is defined as:

$$BS_{mux} = 0.004 \text{ seconds} \times \max\{ BrNalFactor \times MaxBR[tier, level], 2\,000\,000 \text{ bit/s} \}$$

$MaxCPB[tier, level]$  and  $MaxBR[tier, level]$  are taken from Annex A of Rec. ITU-T H.265 | ISO/IEC 23008-2 for the tier and level of the HEVC video stream or HEVC temporal video sub-bitstream where rates are expressed in bit/s.  $cpb\_size$  is taken from the HRD parameters, as specified in Annex E of Rec. ITU-T H.265 | ISO/IEC 23008-2, included in the HEVC video stream or HEVC temporal video sub-bitstream, where the size is expressed in bits. Implicit conversion is carried out according to Note 2 in 2.4.2.4.

- There is exactly one elementary stream buffer  $EB_n$  for all the elementary streams in the set of received elementary streams associated by hierarchy descriptors, with a total size  $EBS_n$

$$EBS_n = cpb\_size$$

where  $cpb\_size$  is taken from the HRD parameters, as specified in Annex E of Rec. ITU-T H.265 | ISO/IEC 23008-2, included in the HEVC video stream or the HEVC temporal video sub-bitstream, where the size is expressed in bits. Implicit conversion is carried out according to Note 2 in 2.4.2.4.

- Transfer from  $TB_n$  to  $MB_n$  is applied as follows:

When there is no data in  $TB_n$  then  $Rx_n$  is equal to zero. Otherwise:

$$Rx_n = \text{bit\_rate}$$

where  $\text{bit\_rate}$  is  $BrNalFactor/BrVlcFactor \times \text{BitRate}[\text{SchedSelIdx}]$  of data flow into the CPB for the byte stream format and  $\text{BitRate}[\text{SchedSelIdx}]$  is as defined in Annex E of Rec. ITU-T H.265 | ISO/IEC 23008-2 when  $NAL\ hrd\_parameters()$  is present in the VUI parameters of the HEVC video stream.

NOTE – Annex E also specifies default values for  $\text{BitRate}[\text{SchedSelIdx}]$  based on profile, tier and level when  $NAL\ HRD$  parameters are not present in the VUI.

- Transfer from  $MB_n$  to  $EB_n$  is applied as follows:

If the *HEVC\_timing\_and\_HRD\_descriptor* is present with the *hrd\_management\_valid\_flag* set to '1' for the elementary stream, then the transfer of data from  $MB_n$  to  $EB_n$  shall follow the HRD defined scheme for data arrival in the CPB of the elementary stream as defined in Annex C of Rec. ITU-T H.265 | ISO/IEC 23008-2.

Otherwise, the leak method shall be used to transfer data from  $MB_n$  to  $EB_n$  as follows:

$$Rbx_n = BrNalFactor \times MaxBR[tier, level]$$

where  $MaxBR[tier, level]$  is taken from Annex A of Rec. ITU-T H.265 | ISO/IEC 23008-2 for the tier and level of the HEVC video stream or HEVC temporal video sub-bitstream.

If there is PES packet payload data in  $MB_n$ , and buffer  $EB_n$  is not full, the PES packet payload is transferred from  $MB_n$  to  $EB_n$  at a rate equal to  $Rbx_n$ . If  $EB_n$  is full, data are not removed from  $MB_n$ . When a byte of data is transferred from  $MB_n$  to  $EB_n$ , all PES packet header bytes that are in  $MB_n$  and precede that byte are instantaneously removed and discarded. When there is no PES packet payload data present in  $MB_n$ , no data is removed from  $MB_n$ . All data that enters  $MB_n$  leaves it. All PES packet payload data bytes enter  $EB_n$  instantaneously upon leaving  $MB_n$ .

### STD delay

The STD delay of any ITU-T H.265 | ISO/IEC 23008-2 data other than HEVC still picture data through the system target decoders buffers  $TB_n$ ,  $MB_n$ , and  $EB_n$  shall be constrained by  $td_n(j) - t(i) \leq 10$  seconds for all  $j$ , and all bytes  $i$  in access unit  $A_n(j)$ .

The delay of any HEVC still picture data through the system target decoders  $TB_n$ ,  $MB_n$ , and  $EB_n$  shall be constrained by  $td_n(j) - t(i) \leq 60$  seconds for all  $j$ , and all bytes  $i$  in access unit  $A_n(j)$ .

### Buffer management conditions

Transport streams shall be constructed so that the following conditions for buffer management are satisfied:

- Each  $TB_n$  shall not overflow and shall be empty at least once every second.
- Each  $MB_n$ ,  $EB_n$  and DPB shall not overflow.

- $EB_n$  shall not underflow, except when VUI parameters are present for the HEVC video sequence with the *low\_delay\_hrd\_flag* set to '1'. Underflow of  $EB_n$  occurs for HEVC access unit  $A_n(j)$  when one or more bytes of  $A_n(j)$  are not present in  $EB_n$  at the decoding time  $td_n(j)$ .

**2.17.3 T-STD extensions for layered transport of HEVC temporal video subsets**

When there is an HEVC video sub-bitstream and at least one associated elementary stream of type 0x25 in an ITU-T H.222.0 | ISO/IEC 13818-1 program, the T-STD model as described in 2.4.2.1 is extended as illustrated in Figure 2-21 and as specified below.

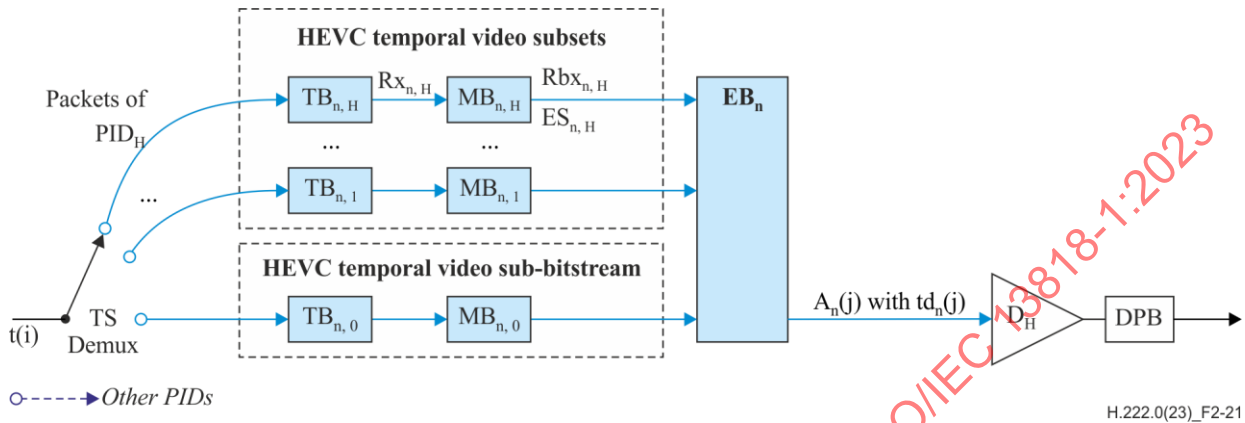

**Figure 2-21 – T-STD model extensions for layered transport of HEVC temporal video subsets**

The following additional notations are used to describe the T-STD extensions and are illustrated in Figure 2-21.

- $t(i)$  indicates the time in seconds at which the  $i$ -th byte of the transport stream enters the system target decoder.
- $H$  is the number of received HEVC temporal video subsets, associated by hierarchy descriptors with the same HEVC temporal video sub-bitstream.
- $k$  is an index identifying the  $H+1$  received elementary streams which contain exactly one HEVC temporal video sub-bitstream and  $H$  HEVC temporal video subsets associated by hierarchy descriptors. The index value  $k$  equal to 0 identifies the elementary stream which contains the HEVC temporal video sub-bitstream and index values  $k$  ranging from 1 up to  $H$  identify the associated HEVC temporal video subsets.
- $ES_{n,k}$  is the received elementary stream which contains the  $k$ -th HEVC temporal video subset or the HEVC temporal video sub-bitstream if  $k$  equals 0.
- $ES_{n,H}$  is the received elementary stream containing the highest HEVC temporal video subset present in the set of received elementary streams.
- $PID_H$  is the packet identifier value which identifies  $ES_{n,H}$ .
- $j$  is an index to the output access units.
- $A_n(j)$  is the  $j$ -th access unit of the HEVC complete temporal representation.
- $td_n(j)$  is the decoding time of  $A_n(j)$  in the system target decoder.
- $TB_{n,k}$  is the transport buffer for elementary stream  $k$ .
- $TBS_{n,k}$  is the size of the transport buffer  $TB_{n,k}$ , measured in bytes.
- $MB_{n,k}$  is the multiplexing buffer for elementary stream  $k$ .
- $MBS_{n,k}$  is the size of the multiplexing buffer  $MB_{n,k}$ , measured in bytes.
- $EB_n$  is the elementary stream buffer for the received HEVC temporal video sub-bitstream  $ES_{n,0}$  and the received HEVC temporal video subsets  $ES_{n,1}$  to  $ES_{n,H}$ .
- $EBS_n$  is the size of elementary stream buffer  $EB_n$ , measured in bytes.
- $R_{X_{n,k}}$  is the transfer rate from the  $k$ -th transport buffer  $TB_{n,k}$  to the  $k$ -th multiplex buffer  $MB_{n,k}$  as specified below.
- $R_{B_{X_{n,k}}}$  is the transfer rate from the  $k$ -th multiplex buffer  $MB_{n,k}$  to the elementary stream buffer  $EB_n$  as specified below.

NOTE – The index  $n$ , where used, indicates that the received elementary streams and associated buffers belong to a certain HEVC temporal video sub-bitstream and its associated HEVC temporal video subsets, distinguishing these elementary streams and associated buffers from other elementary streams and buffers, maintaining consistency with the notation in Figure 2-20.

### TB<sub>n,k</sub>, MB<sub>n,k</sub>, EB<sub>n</sub> buffer management

The following apply:

- There is one transport buffer TB<sub>n,k</sub> for each received elementary stream ES<sub>n,k</sub>, where the size TBS<sub>n,k</sub> is fixed to 512 bytes.
- There is one multiplex buffer MB<sub>n,k</sub> for each received elementary stream ES<sub>n,k</sub>, where the size MBS<sub>n,k</sub> of the multiplex buffer MB<sub>n,k</sub> is constrained as follows:

$$MBS_{n,k} = BS_{mux} + BS_{oh} + CpbNalFactor \times MaxCPB[tier, level] - cpb\_size$$

where

BS<sub>oh</sub>, packet overhead buffering, and BS<sub>mux</sub>, additional multiplex buffering, are as specified in 2.17.2;

MaxCPB[tier, level] and MaxBR[tier, level] are taken from the tier and level specification of HEVC for the tier and level of the HEVC highest temporal sub-layer representation associated with ES<sub>n,k</sub>;

cpb\_size is taken from the HRD parameters, as specified in Annex E of Rec. ITU-T H.265 | ISO/IEC 23008-2, included in the HEVC highest temporal sub-layer representation associated with ES<sub>n,k</sub>. In the HRD parameters, cpb\_size is expressed in bits, and its value is implicitly converted into a value expressed in bytes according to Note 2 in 2.4.2.4.

- There is exactly one elementary stream buffer EB<sub>n</sub> for the  $H + 1$  elementary streams in the set of received elementary streams ES<sub>n,0</sub> to ES<sub>n,H</sub>, with a total size EBS<sub>n</sub>

$$EBS_n = cpb\_size$$

where cpb\_size is taken from the HRD parameters, as specified in Annex E of Rec. ITU-T H.265 | ISO/IEC 23008-2, included in the HEVC highest temporal sub-layer representation associated with ES<sub>n,H</sub>. In the HRD parameters, cpb\_size is expressed in bits, and its value is implicitly converted into a value expressed in bytes according to Note 2 in 2.4.2.4.

- Transfer from TB<sub>n,k</sub> to MB<sub>n,k</sub> is applied as follows:

When there is no data in TB<sub>n,k</sub> then Rx<sub>n,k</sub> is equal to zero. Otherwise:

$$Rx_{n,k} = bit\_rate$$

where bit\_rate is as specified in 2.17.2.

- Transfer from MB<sub>n,k</sub> to EB<sub>n</sub> is applied as follows:

If the HEVC\_timing\_and\_HRD\_descriptor is present with the hrd\_management\_valid\_flag set to '1' for the HEVC video sub-bitstream, then the transfer of data from MB<sub>n,k</sub> to EB<sub>n</sub> shall follow the HRD defined scheme for data arrival in the CPB of elementary stream ES<sub>n,H</sub> as defined in Annex C of Rec. ITU-T H.265 | ISO/IEC 23008-2.

Otherwise, the leak method shall be used to transfer data from MB<sub>n,k</sub> to EB<sub>n</sub> as follows:

$$Rbx_{n,k} = BrNalFactor \times MaxBR[tier, level]$$

where MaxBR[tier, level] is defined for the byte stream format in Annex A of Rec. ITU-T H.265 | ISO/IEC 23008-2 for the tier and level of the HEVC video stream or the HEVC highest temporal sub-layer representation associated with ES<sub>n,k</sub>.

If there is PES packet payload data in MB<sub>n,k</sub>, and EB<sub>n</sub> is not full, the PES packet payload is transferred from MB<sub>n,k</sub> to EB<sub>n</sub> at a rate equal to Rbx<sub>n,k</sub>. If EB<sub>n</sub> is full, data are not removed from MB<sub>n,k</sub>. When a byte of data is transferred from MB<sub>n,k</sub> to EB<sub>n</sub>, all PES packet header bytes that are in MB<sub>n,k</sub> and precede that byte are instantaneously removed and discarded. When there is no PES packet payload data present in MB<sub>n,k</sub>, no data is removed from MB<sub>n,k</sub>. All data that enters MB<sub>n,k</sub> leaves it. All PES packet payload data bytes enter EB<sub>n</sub> instantaneously upon leaving MB<sub>n,k</sub>.

At the output of the elementary stream buffer EB<sub>n</sub>, the elementary streams are aggregated by removing all HEVC access units in ascending DTS order and transferring them to the HEVC decoder D<sub>H</sub>, irrespective of which elementary stream ES<sub>n,k</sub> each HEVC access unit belongs to.

### STD delay

The STD delay of any ITU-T H.265 | ISO/IEC 23008-2 data other than HEVC still picture data through the system target decoders buffers TB<sub>n,k</sub>, MB<sub>n,k</sub>, and EB<sub>n</sub> shall be constrained by  $td_n(j) - t(i) \leq 10$  seconds for all  $k$ , all  $j$ , and all bytes  $i$  in access unit A<sub>n</sub>( $j$ ).

The delay of any HEVC still picture data through the system target decoders  $TB_{n,k}$ ,  $MB_{n,k}$ , and  $EB_n$  shall be constrained by  $td_n(j) - t(i) \leq 60$  seconds for all  $k$ , all  $j$ , and all bytes  $i$  in access unit  $A_n(j)$ .

**Buffer management conditions**

Transport streams shall be constructed so that the following conditions for buffer management are satisfied:

- Each  $TB_{n,k}$  shall not overflow and shall be empty at least once every second.
- Each  $MB_{n,k}$ ,  $EB_n$ , and DPB shall not overflow.
- $EB_n$  shall not underflow, except when VUI parameters are present for the HEVC video sequence with the *low\_delay\_hrd\_flag* set to '1'. Underflow of  $EB_n$  occurs for HEVC access unit  $A_n(j)$  when one or more bytes of  $A_n(j)$  are not present in  $EB_n$  at the decoding time  $td_n(j)$ .

**2.17.4 T-STD extensions for layered transport of HEVC sub-partitions with bitstream-partition-specific CPB operation**

When there is at least one elementary stream with *stream\_type* value in the range of 0x28 to 0x2B in a Rec. ITU-T H.222.0 | ISO/IEC 13818-1 program, the T-STD model as described in 2.4.2.1 is extended for elementary streams with a *stream\_type* value in the range of 0x28 to 0x2B as illustrated in Figure 2-22 and as specified below.

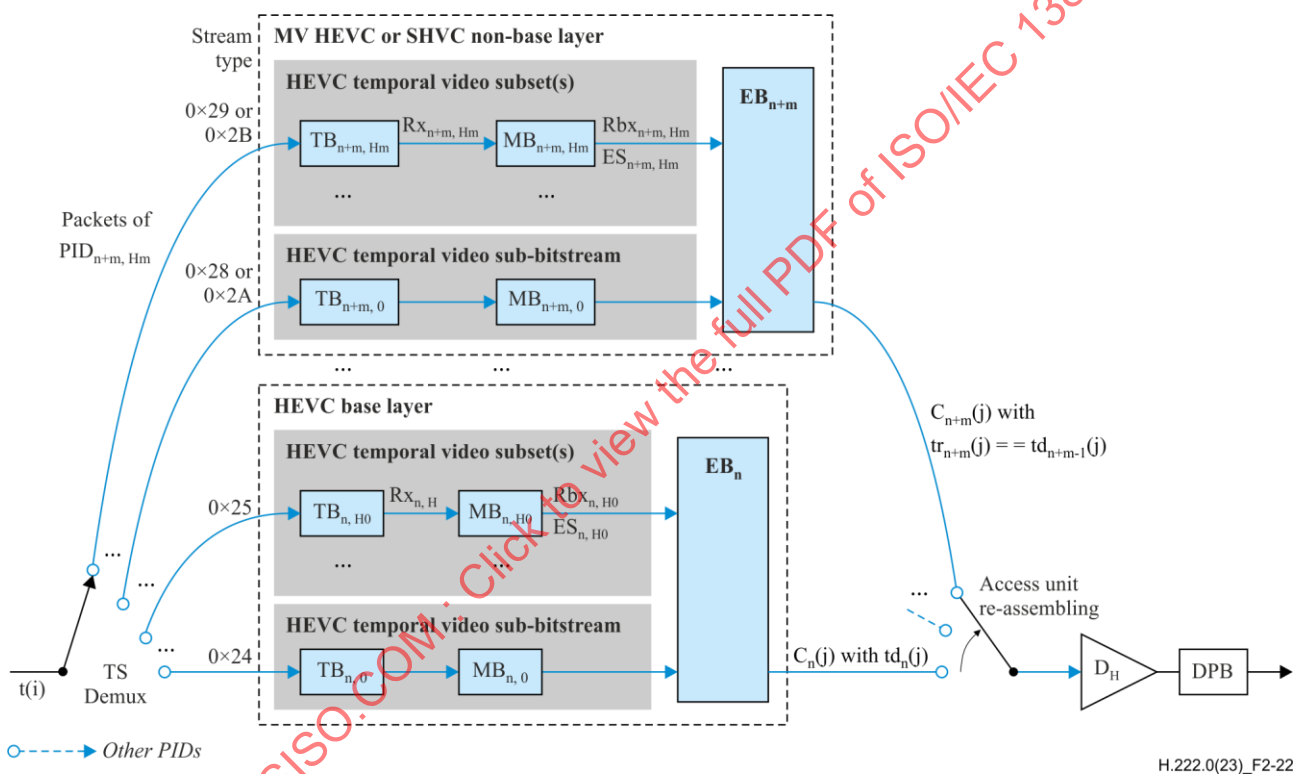

**Figure 2-22 – T-STD model extensions for bitstream-partition-specific CPB operation**

NOTE – The lower dashed box containing blocks that handle the HEVC base layer represents the T-STD buffer model as specified in 2.17.2, if there are no HEVC temporal video subsets, or 2.17.3, if the program contains at least one program element with *stream\_type* equal to 0x25.

The following additional notations are used to describe the T-STD extensions and are illustrated in Figure 2-22.

- $t(i)$  Indicates the time in seconds at which the  $i$ -th byte of the transport stream enters the system target decoder.
- $l$  Is an index into the received HEVC sub-partitions of *stream\_type* 0x28 or 0x2A (which include TemporalId 0). The order of HEVC sub-partitions is indicated by the HEVC operation point descriptor. The same index also applies to corresponding HEVC temporal enhancement sub-partitions. Here,  $l$  starts from  $n$ , which is associated with the HEVC base sub-partition, and runs up to  $(n+m)$ , where  $m$  is specified below.
- $m$  Is the number of received HEVC sub-partitions of *stream\_type* 0x28 or 0x2A.
- $H_l$  Is the number of received HEVC corresponding temporal enhancement sub-partitions of the  $l$ -th received HEVC sub-partition of *stream\_type* 0x28 or 0x2A, associated by HEVC hierarchy extension descriptors with the same HEVC base sub-partition.

$ES_{l,k}$	Is the received elementary stream which contains the k-th HEVC corresponding temporal enhancement sub-partition of the l-th received HEVC sub-partition of stream_type 0x28 or 0x2A, or the l-th HEVC sub-partition of stream_type 0x28 or 0x2A if k equals 0.
$ES_{n+m,Hm}$	Is the received elementary stream which contains the HEVC sub-partition of the highest HEVC operation point in the set of received elementary streams.
$PID_{n+m,Hm}$	Is the packet identifier value which identifies $ES_{n+m,Hm}$ .
j	Is an index to the output HEVC access units.
$C_l(j)$	Is the j-th HEVC layer component of the l-th received HEVC sub-partition of stream_type 0x28 or 0x2A or HEVC corresponding temporal enhancement sub-partition.
$A_n(j)$	Is the j-th HEVC access unit of the HEVC complete temporal representation.
$td_n(j)$	Is the decoding time of $A_n(j)$ in the system target decoder.
$tr_l(j)$	Is the value of TREF, if available in the PES header attached to $C_l(j)$ , else the decoding time of $A_n(j)$ in the system target decoder.
$TB_{l,k}$	Is the transport buffer for elementary stream $ES_{l,k}$ .
$TBS_{l,k}$	Is the size of the transport buffer $TB_{l,k}$ , measured in bytes.
$MB_{l,k}$	Is the multiplexing buffer for elementary stream $ES_{l,k}$ .
$MBS_{l,k}$	Is the size of the multiplexing buffer $MB_{l,k}$ , measured in bytes.
$EB_l$	Is the elementary stream buffer for the received HEVC temporal video sub-bitstream $ES_{l,0}$ and the received HEVC temporal video subsets $ES_{l,1}$ to $ES_{l,H}$ .
NOTE 1	– Each buffer $EB_l$ contains one partition as specified in Annex F of Rec. ITU-T H.265   ISO/IEC 23008-2.
$EBS_l$	Is the size of elementary stream buffer $EB_l$ , measured in bytes.
$RX_{l,k}$	Is the transfer rate from the k-th transport buffer $TB_{l,k}$ to the k-th multiplex buffer $MB_{l,k}$ as specified below.
$RbX_{l,k}$	Is the transfer rate from the k-th multiplex buffer $MB_{l,k}$ to the elementary stream buffer $EB_l$ as specified below.

NOTE 2 – The index n, where used, indicates that the received elementary streams and associated buffers belong to a certain HEVC base sub-partition, distinguishing these elementary streams and associated buffers from other elementary streams and buffers, maintaining consistency with the notation in Figure 2-1 and other T-STD extensions.

### **$TB_{l,k}$ , $MB_{l,k}$ , $EB_l$ buffer management**

The following applies:

- There is one transport buffer  $TB_{l,k}$  for each received elementary stream  $ES_{l,k}$ , where the size  $TBS_{l,k}$  is fixed to 512 bytes.
- There is one multiplex buffer  $MB_{l,k}$  for each received elementary stream  $ES_{l,k}$ , where the size  $MBS_{l,k}$  of the multiplex buffer  $MB_{l,k}$  is constrained as follows:

$$MBS_{l,k} = BS_{mux} + BS_{oh} + CpbNalFactor \times MaxCPB[tier, level] - cpb\_size$$

where

$BS_{oh}$ , packet overhead buffering, and  $BS_{mux}$ , additional multiplex buffering, are as specified in 2.17.2;

$MaxCPB[tier, level]$  and  $MaxBR[tier, level]$  are taken from the tier and level specification of the HEVC for the tier and level of  $ES_{l,k}$  the HEVC operation point associated with  $ES_{l,k}$ ;

$cpb\_size$  is taken from the sub-layer HRD parameters within the applicable  $hrd\_parameters()$ , as specified in Annex F of Rec. ITU-T H.265 | ISO/IEC 23008-2, for the HEVC operation point associated with  $ES_{l,k}$ . In the HRD parameters,  $cpb\_size$  is expressed in bits, and its value is implicitly converted into a value expressed in bytes according to Note 2 in 2.4.2.4.

- There is one elementary stream buffer  $EB_l$  for the  $HI + 1$  elementary streams in the set of received elementary streams  $ES_{l,0}$  to  $ES_{l,m,HI}$ , with a total size  $EBS_l$

$$EBS_l = cpb\_size$$

where  $cpb\_size$  is taken from the sub-layer HRD parameters within the applicable  $hrd\_parameters()$ , as specified in Annex F of Rec. ITU-T H.265 | ISO/IEC 23008-2, for the HEVC operation point associated with  $ES_{l,H}$ . In the HRD parameters,  $cpb\_size$  is expressed in bits, and its value is implicitly converted into a value expressed in bytes according to Note 2 in 2.4.2.4.

- Transfer from  $TB_{i,k}$  to  $MB_{i,k}$  is applied as follows:
  - When there is no data in  $TB_{i,k}$  then  $R_{X_{i,k}}$  is equal to zero.
  - Otherwise,  $R_{X_{i,k}} = \text{bit\_rate}$

$\text{bit\_rate}$  is taken from the NAL HRD parameters within the applicable  $\text{hrd\_parameters}()$ , as specified in Annex F of Rec. ITU-T H.265 | ISO/IEC 23008-2, for the HEVC operation point associated with  $ES_{i,k}$ , if sub-layer HRD parameters are present in the VPS and  $\text{nal\_hrd\_parameters\_present\_flag}$  is set to '1'.

Otherwise:

$\text{bit\_rate} = \text{BrNalFactor} / \text{BrVclFactor} \times \text{BitRate}_{\text{VCL}}$ , if sub-layer HRD parameters within the applicable  $\text{hrd\_parameters}()$ , as specified in Annex F of Rec. ITU-T H.265 | ISO/IEC 23008-2, for the HEVC operation point associated with  $ES_{i,k}$  are present in the VPS and  $\text{vcl\_hrd\_parameters\_present\_flag}$  is set to '1';  $\text{BitRate}_{\text{VCL}}$  is taken from the VCL HRD parameters.

$\text{BrNalFactor}$  and  $\text{BrVclFactor}$  are as defined in Rec. ITU-T H.265 | ISO/IEC 23008-2 for the profile, tier, and level of  $ES_{i,k}$  the HEVC operation point associated with  $ES_{i,k}$ .

In both cases, the index of the applicable  $\text{hrd\_parameters}()$  syntax structure in the active VPS of the HEVC video stream is given by:  $\text{bsp\_hrd\_idx}[\text{target\_ols}][0][\text{max\_temporal\_id}][\text{target\_schedule\_idx}][1+1]$  as specified in Annex F of Rec. ITU-T H.265 | ISO/IEC 23008-2, where  $\text{target\_ols}$  and  $\text{max\_temporal\_id}$  are signalled in the HEVC operation point descriptor for the HEVC operation point associated with  $ES_{i,k}$ , and  $\text{target\_schedule\_idx}$  is signalled in the HEVC timing and HRD descriptor.

- Transfer from  $MB_{i,k}$  to  $EB_1$  is applied as follows:
  - If the  $\text{HEVC\_timing\_and\_HRD\_descriptor}$  is present with the  $\text{hrd\_management\_valid\_flag}$  set to '1' for the HEVC video sub-bitstream, then the transfer of data from  $MB_{i,k}$  to  $EB_1$  shall follow the HRD defined scheme for data arrival in the CPB of elementary stream  $ES_{i,H}$  as defined in Annex C of Rec. ITU-T H.265 | ISO/IEC 23008-2.
  - Otherwise, the leak method shall be used to transfer data from  $MB_{i,k}$  to  $EB_1$  as follows:

$$R_{bx_{n,k}} = \text{BrNalFactor} \times \text{MaxBR}[\text{tier}, \text{level}]$$

where  $\text{MaxBR}[\text{tier}, \text{level}]$  is as defined for the byte stream format in the tier and level specification of Rec. ITU T H.265 | ISO/IEC 23008-2 (Table A.2) for the tier and level for  $ES_{i,k}$  signalled in the HEVC operation point descriptor for  $ES_{i,k}$ .

If there is PES packet payload data in  $MB_{i,k}$ , and  $EB_1$  is not full, the PES packet payload is transferred from  $MB_{i,k}$  to  $EB_1$  at a rate equal to  $R_{bx_{i,k}}$ . If  $EB_1$  is full, data are not removed from  $MB_{i,k}$ . When a byte of data is transferred from  $MB_{i,k}$  to  $EB_1$ , all PES packet header bytes that are in  $MB_{i,k}$  and precede that byte are instantaneously removed and discarded. When there is no PES packet payload data present in  $MB_{i,k}$ , no data is removed from  $MB_{i,k}$ . All data that enters  $MB_{i,k}$  leaves it. All PES packet payload data bytes enter  $EB_1$  instantaneously upon leaving  $MB_{i,k}$ .

**Aggregation of elementary streams**

The HEVC layer list for an HEVC operation point is the  $\text{OperationPointESList}[]$  associated with the HEVC operation point.

When there is no hierarchy descriptor or HEVC hierarchy extension descriptor present in the program map table associated with an Rec. ITU-T H.222.0 | ISO/IEC 13818-1 program, a value for the  $\text{hierarchy\_layer\_index}$  is implicitly assigned for each elementary stream with  $\text{stream\_type}$  0x24, 0x25, 0x28, 0x29, 0x2A and 0x2B as described in Table 2-161.

**Table 2-161 – Implied hierarchy\_layer\_index if no hierarchy descriptors are used**

Existing stream types	Implied hierarchy_layer_index for program element with stream_type value					
	0x24	0x25	0x28	0x29	0x2A	0x2B
0x24	0					
0x24, 0x25	0	1				
0x24, 0x28	0		1			
0x24, 0x25, 0x28	0	1	2			
0x24, 0x25, 0x28, 0x29	0	1	2	3		
0x24, 0x2A	0				1	
0x24, 0x2A, 0x2B	0				1	2
0x24, 0x25, 0x2A	0	1			2	
0x24, 0x25, 0x2A, 0x2B	0	1			2	3

The HEVC operation point is aggregated from the HEVC layer components at the output of the elementary stream buffers  $EB_l$  by determining the value of TREF, if available in the PES header, or else TREF is set to DTS, for the next HEVC layer component at the output of  $EB_{n+m}$ , and gathering all HEVC layer components with a DTS equal to TREF, in the order given by the HEVC layer list as specified above, and transferring them to the HEVC decoder  $D_H$ .

### Carriage in PES packets

For correct re-assembling of the HEVC layer components to an HEVC access unit, if there is an HEVC dependency representation in the same HEVC access unit in more than one elementary stream, the following applies:

- Each PES packet shall contain exactly one HEVC layer component;
- The PTS and, if applicable, the DTS value shall be provided in the PES header of each HEVC layer component;
- If the DTS value of the HEVC layer component in an elementary stream is different from the DTS value of the HEVC layer component of the same HEVC access unit in an ES listed in the hierarchy descriptor or the HEVC hierarchy extension descriptors of the first elementary stream, the TREF field as defined in 2.4.3.7 shall be present in the PES header extension of the HEVC layer component of first elementary stream and the TREF field value shall be equal to the DTS value of the HEVC layer component of the second elementary stream.

### STD delay

The STD delay of any Rec. ITU-T H.265 | ISO/IEC 23008-2 data other than HEVC still picture data through the System Target Decoders buffers  $TB_{l,k}$ ,  $MB_{l,k}$ , and  $EB_l$  shall be constrained by  $td_l(j) - t(i) \leq 10$  seconds for all  $l$ , all  $k$ , all  $j$ , and all bytes  $i$  in HEVC access unit  $A_n(j)$ .

The delay of any HEVC still picture data through the system target decoders  $TB_{l,k}$ ,  $MB_{l,k}$ , and  $EB_l$  shall be constrained by  $td_l(j) - t(i) \leq 60$  seconds for all  $l$ , all  $k$ , all  $j$ , and all bytes  $i$  in HEVC access unit  $A_n(j)$ .

### Buffer management conditions

Transport streams shall be constructed so that the following conditions for buffer management are satisfied:

- Each  $TB_{l,k}$  shall not overflow and shall be empty at least once every second;
- Each  $MB_{l,k}$ ,  $EB_l$ , and DPB shall not overflow;
- $EB_l$  shall not underflow, except when VUI parameters are present for the HEVC video sequence with the `low_delay_hrd_flag` set to '1'. Underflow of  $EB_l$  occurs for HEVC access unit  $A_n(j)$  when one or more bytes of  $A_n(j)$  are not present in  $EB_l$  at the decoding time  $td_n(j)$ .

## 2.17.5 T-STD Extensions for the carriage of HEVC tiles

### 2.17.5.1 Carriage of HEVC motion-constrained tile sets

There are alternative options to carry the HEVC tile substreams:

- I. Each HEVC tile substream is carried in a separate ES.
- II. More than one HEVC tile substreams is carried in a common ES. Within this ES, HEVC tile substream `af_descriptors` are used to indicate different HEVC tile substreams.

In the first approach, the sender generates one slice per tile and all slice headers are stripped off before packetizing the slice data of each slice into a PES packet, building a separate ES per HEVC tile substream. In addition, it generates a separate ES per subregion layout that provides suitable slice headers and parameters sets that, when combined with the slice data, result in a compliant HEVC bitstream. All ESs with stream type equal to 0x31 that belong to the same program shall be referenced in the HEVC subregion descriptor that is associated to that program. If using stream type equal to 0x31, all ESs referring to the picture shall be of type equal to 0x31.

The second approach eases the allocation of receiver buffers while it allows to remove HEVC tile substreams that are not part of the desired subregion from the output of the demultiplexer before they reach the CPB of the decoder. The usage of HEVC tile substream `af_descriptors` is indicated in the HEVC subregion descriptor. HEVC tile substream `af_descriptors` assign a unique substream ID to each TS packet. Adaptation field padding shall be used in order to align the end of an HEVC tile substream for an access unit with the end of a TS packet.

### 2.17.5.2 Carriage of HEVC motion-constrained tile sets as separate elementary streams

When HEVC motion-constrained tile sets are carried as separate elementary streams using the `stream_type` value 0x31, the data in each  $SBi$ , where  $i$  ranges from  $n$  to  $(n+m)$  in Figure 2-23, belongs to a certain HEVC tile substream and data of multiple substream buffers can be gathered to form the encoded representation of a subregion. Which set of ESs needs

to be aggregated in which order is signalled by the information conveyed in descriptors specified below, which are found in the PMT for that program. The buffer model shown in 2-23 is applicable when SubstreamMarkingFlag is set to '1'.

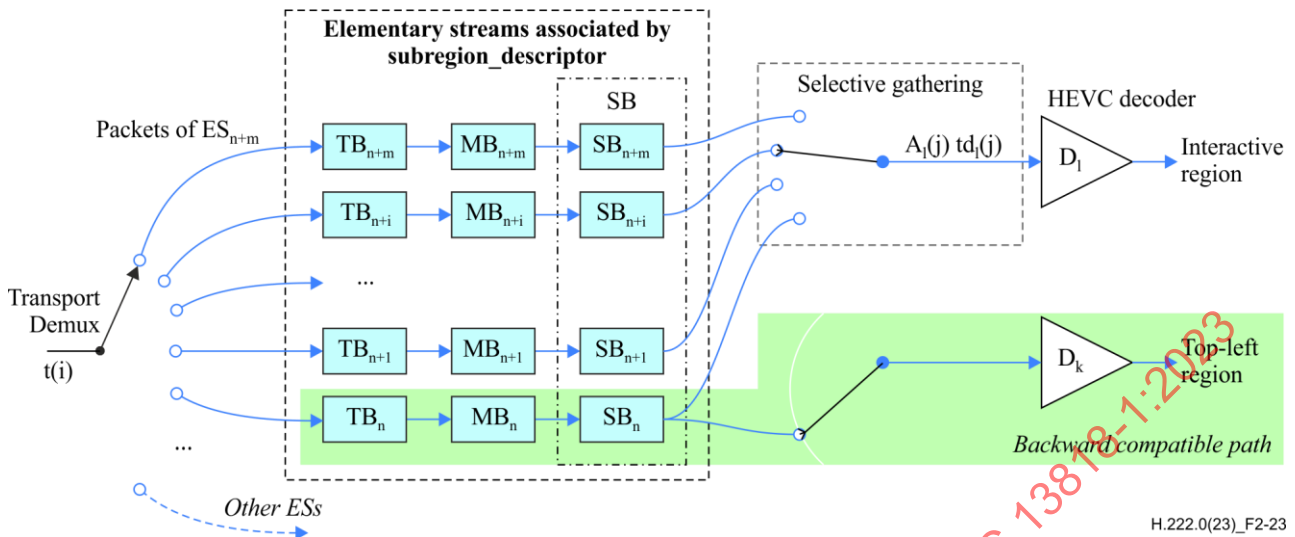

Figure 2-23 – T-STD model extensions for transport of HEVC tiles through individual ESs

For each subregion indexed by the value of *i* in the HEVC subregion descriptor, the parameter sets corresponding to the subregion shall be present in the HEVC tile substream with the SubstreamID equal to PreambleSubstreamID[*i*] signalled in the HEVC subregion descriptor. In an HEVC tile substream with an HEVC tile substream descriptor with a PreambleFlag resp. Flag[0] value equal to '0', the parameter sets corresponding to the subregion shall also be present.

NOTE – If any HEVC tile substream descriptor of an ES that belongs to a certain program contains a PreambleFlag resp. Flag[0] equal to '0', only one subregion size can be signalled in the HEVC subregion descriptor for that program.

**Process to access a subregion:**

The HEVC subregion descriptor and all HEVC tile substream descriptors shall be read.

First, the receiver chooses a suitable subregion size from the HEVC subregion descriptor based on the level indication or the subregion dimension. This selection implicitly results in a value *i*.

Next, it selects the ES that contains the upper left HEVC tile substream of the region to be displayed based on the SubstreamID.

Next, it checks if the applicable HEVC tile substream descriptor provides a PatternReference value.

With that PatternReference, it selects the applicable SubstreamOffset values:

$$SubstreamOffset[k][PatternReference][i] \text{ with } 0 < k < SubstreamCountMinus1[i]$$

If there is no explicit PatternReference value, which means that either descriptor\_length equals 1 or ReferenceFlag equals 0, the index *j* defaults to a value of 0.

For each PES packet of the ES<sub>x</sub> with an HEVC tile substream descriptor indicating a SubstreamID equal to SubstreamID<sub>x</sub>, the following operations are executed, if the stated condition is met:

- If PreambleFlag resp. Flag[0] signalled in the HEVC tile substream descriptor equals '1': prepend the PES packets with the same DTS of the ES with an HEVC tile substream descriptor indicating a SubstreamID equal to PreambleSubstreamID[*i*] signalled in the HEVC subregion descriptor
- If SubstreamCountMinus1[*i*] > 0: append the PES packets with the same DTS of ESs with an HEVC tile substream descriptor indicating a SubstreamID equal to AdditionalSubstreamID[*i*] given in the HEVC tile substream descriptor of ES<sub>x</sub> resp. (SubstreamID<sub>x</sub> + SubstreamOffset[*k*][*j*]), where the SubstreamOffset array is found in the subregion descriptor, with *j* given by the value of PatternReference in the HEVC tile substream descriptor of ES<sub>x</sub> and *k* ranging from 0 to SubstreamCountMinus1[*i*] prior to decoding. The order of the PES packets in the assembled bitstream is given by values of SubstreamID ordered with increasing values of the index *k*.

**TB<sub>n</sub>, MB<sub>n</sub>, EB<sub>n</sub> buffer management**

The following additional notations are used to describe the T-STD extensions and are illustrated in Figure 2-23.

- H is the number of received HEVC tile substreams of the subregion.
- ES<sub>n</sub> is the received elementary stream of the n-th HEVC tile substream of the subregion.
- TB<sub>n</sub> is the transport buffer for the n-th elementary stream of the subregion.
- TBS<sub>n</sub> is the size of the transport buffer TB<sub>n</sub> measured in bytes.
- MB<sub>n</sub> is the multiplex buffer for the n-th elementary stream.
- MBS<sub>n</sub> is the size of the multiplex buffer MB<sub>n</sub> measured in bytes.
- SB<sub>n</sub> is the substream buffer for the n-th elementary stream.
- SBS<sub>n</sub> is the size of the n-th substream buffer SB<sub>n</sub> measured in bytes.
- SB is the substream buffer for all the received H elementary streams.
- SBS is the size of elementary stream buffer EBH, measured in bytes.

The following applies:

- There is exactly one transport buffer TB<sub>n</sub> for each received elementary stream of the subregion as shown in Figure 2-23, where the size TBS<sub>n</sub> is fixed to 512 bytes.
- There is exactly one multiplex buffer MB<sub>n</sub> for each received elementary stream of the subregion as shown in Figure 2-23, where the size of the multiplex buffer MBS<sub>n</sub> is constrained as follows:

$$MBS_n = BS_{mux} + BS_{oh} + CpbNalFactor \times MaxCPB[tier, level] - cpb\_size \text{ (measured in bytes)}$$

where BS<sub>oh</sub>, packet overhead buffering, is defined as:

$$BS_{oh} = (1/750) \text{ seconds} \times \max\{ BrNalFactor \times MaxBR[tier, level], 2\,000\,000 \text{ bit/s} \}$$

and BS<sub>mux</sub>, additional multiplex buffering, is defined as:

$$BS_{mux} = 0.004 \text{ seconds} \times \max\{ BrNalFactor \times MaxBR[tier, level], 2\,000\,000 \text{ bit/s} \}$$

MaxCPB[tier, level] and MaxBR[tier, level] are taken from Annex A of Rec. ITU-T H.265 | ISO/IEC 23008-2 for the tier and level as indicated by the parameter sets set carried in the substream with the SubstreamID equal to to PreambleSubstreamID[i] signalled in the HEVC subregion descriptor. cpb\_size is taken from the HRD parameters, as specified in Annex E of Rec. ITU-T H.265 | ISO/IEC 23008-2, present in the parameter sets carried in the substream with the SubstreamID equal to to PreambleSubstreamID[i] signalled in the HEVC subregion descriptor.

- There is exactly one subregion buffer SB for all the elementary streams in the set of received elementary streams of the subregion as shown in Figure 2-23, of which the size SBS has the following value:

$$SBS = cpb\_size_n$$

where cpb\_size<sub>n</sub> is the cpb\_size taken from the HRD parameters, as specified in Annex E of Rec. ITU-T H.265 | ISO/IEC 23008-2, present in the parameter sets carried in the substream with the SubstreamID equal to to PreambleSubstreamID[i] signalled in the HEVC subregion descriptor.

- There is exactly one substream buffer SB<sub>k</sub> for each elementary stream in the set of received elementary streams of the subregion as shown in Figure 2-23, where each substream buffer SB<sub>k</sub> in the set of received elementary streams of the subregion is allocated within SB. Even though the size of the substream buffer SB<sub>k</sub> is not constrained, the sum of the sizes of all substream buffers SB<sub>n..n+m</sub> is constrained as follows:

$$SBS = \sum_k (SBS_k) \text{ with } n \leq k \leq n+m$$

NOTE – If PreambleFlag resp. Flag[0] signalled in the HEVC tile substream descriptor equals '1', the parameter sets present in the HEVC tile substream with the SubstreamID equal to to PreambleSubstreamID[i] signalled in the HEVC subregion descriptor are the same as the parameter sets encapsulated in the MCTS-EIS SEI message for the subregion. If PreambleFlag resp. Flag[0] signalled in the HEVC tile substream descriptor equals '0', the parameter sets present in that HEVC tile substream are the same as the parameter sets encapsulated in the MCTS-EIS SEI message for the subregion.

2.17.5.3 Carriage of HEVC motion-constrained tile sets in a common ES using AF descriptors

The following approach allows very simple buffer allocation for the buffer that gathers the ES data for the case that SubstreamMarkingFlag is set to 0, because it allows that only a single ES<sub>n</sub> is used for the whole panorama. In this case, a third buffer is introduced after MB, called "RB" (subregion buffer) if it gathers the data that belongs to a subregion (cf. Figure 2-24), or "EB" if it gathers an elementary stream that contains the whole panorama (cf. Figure 2-25).

If SubstreamMarkingFlag is set to 0, no TS packet shall contain data of different HEVC tile substreams. The signalling using HEVC tile substream af\_descriptors as specified in U.3.15 allows removing unnecessary HEVC tile substreams before they enter the MB and RB buffers.

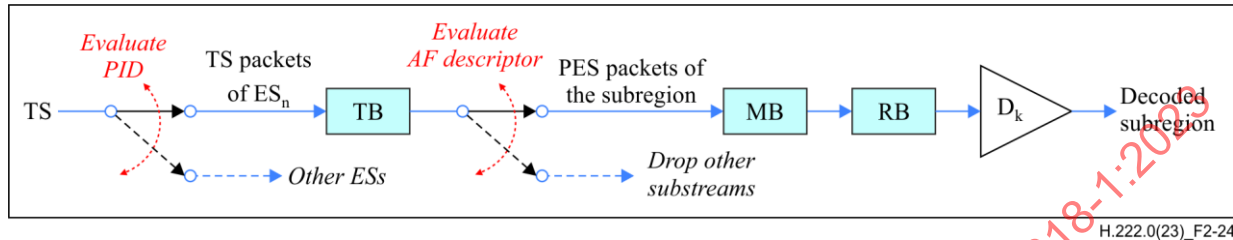

Figure 2-24 – T-STD model extensions for transport of HEVC tiles in a common ES using AF descriptors

The process to access a subregion is similar to the process described in 2.17.5.2:

First, the receiver chooses a suitable subregion size from the subregion descriptor based on the level indication or the subregion dimension. This selection implicitly results in a value *l*.

Next, it selects the SubstreamID<sub>x</sub> that relates to the upper left HEVC tile substream of the region to be displayed.

All adaptation fields of TS packets that belong to ES<sub>n</sub> are read and HEVC tile substream af\_descriptors are evaluated whenever they occur. A SubstreamID that is indicated in an HEVC tile substream af\_descriptor applies to the sequence of TS packets of the same ES<sub>n</sub> starting with the TS packet that contains the HEVC tile substream af\_descriptor indicating that SubstreamID up to the TS packet preceding the TS packet that contains an HEVC tile substream af\_descriptor indicating a different SubstreamID.

NOTE 1 – Adaptation field padding is used in the last TS packet that belongs to a certain HEVC tile substream, if otherwise the data block belonging to that substream does not extend to the last payload byte of a TS packet.

The receiver sets up an empty list of SubstreamIDs that belong to the subregion and adds

- the value 0 and
- the SubstreamID<sub>x</sub> of the upper left HEVC tile substream.

NOTE 2 – SubstreamID value 0 indicates a substream that belongs to any subregion, regardless of its position.

Next, it checks if the applicable HEVC tile substream af\_descriptor provides a PatternReference value. If there is no explicit PatternReference value, which means that either descriptor\_length equals 1 or ReferenceFlag equals 0, the index *j* defaults to a value of 0.

With that PatternReference, it selects the applicable SubstreamOffset values:

$$\text{SubstreamOffset}[k][\text{PatternReference}][i] \text{ with } 0 < k < \text{SubstreamCountMinus1}[i]$$

For each TS packet of the ES<sub>n</sub> with an HEVC tile substream af\_descriptor indicating a SubstreamID equal to SubstreamID<sub>x</sub>, the following operations are executed, if the stated condition is met:

- If SubstreamCountMinus1[*i*] > 0: add SubstreamID equal to AdditionalSubstreamID[*i*] to the list of SubstreamIDs that belong to the subregion, with *i* ranging from 0 to SubstreamCountMinus1[*i*].
- Else if the SubstreamOffset array is found in the subregion descriptor (for the selected subregion layout indexed by *i*), add (SubstreamID<sub>x</sub> + SubstreamOffset[*k*][*j*][*i*]) to the list of SubstreamIDs that belong to the subregion, with *j* given by the value of PatternReference in the HEVC tile substream af\_descriptor with SubstreamID<sub>x</sub> and *k* ranging from 0 to SubstreamCountMinus1[*i*].

For each sequence of TS packets of the ES<sub>n</sub> starting with an HEVC tile substream af\_descriptor indicating a SubstreamID that is contained in the list of SubstreamIDs that belong to the subregion, the TS packets are stored in the MB.

**TB, MB, RB buffer management**

The following notations are used to describe the T-STD extensions and are illustrated in Figure 2-24.

- H is the number of received HEVC tile substreams of the subregion.
- ES<sub>n</sub> is the received elementary stream that contains all HEVC tile substreams.
- TB is the transport buffer for the elementary stream that contains all HEVC tile substreams.
- TBS is the size of the transport buffer TB, measured in bytes.
- MB is the multiplex buffer for the elementary stream. It gathers HEVC tile substreams of the subregion.
- MBS is the size of the multiplex buffer MB, measured in bytes.
- RB is the subregion buffer for all the received H elementary streams of the subregion.
- RBS is the size of the subregion buffer, measured in bytes.

The following applies:

- There is exactly one transport buffer TB for each received elementary stream of the subregion as shown in Figure 2-24, where the size TBS is fixed to 512 bytes.
- There is exactly one multiplex buffer for each received elementary stream of the subregion as shown in Figure 2-24, where the size of the multiplex buffer MBS is constrained as follows:

$$MBS = BS_{\text{mux}} + BS_{\text{oh}} + \text{CpbNalFactor} \times \text{MaxCPB}[\text{tier}, \text{level}] - \text{cpb\_size} \text{ (measured in bytes)}$$

where

BS<sub>oh</sub>, packet overhead buffering, is defined as:

$$BS_{\text{oh}} = (1/750) \text{ seconds} \times \max\{ \text{BrNalFactor} \times \text{MaxBR}[\text{tier}, \text{level}], 2\,000\,000 \text{ bit/s} \}$$

and BS<sub>mux</sub>, additional multiplex buffering, is defined as:

$$BS_{\text{mux}} = 0.004 \text{ seconds} \times \max\{ \text{BrNalFactor} \times \text{MaxBR}[\text{tier}, \text{level}], 2\,000\,000 \text{ bit/s} \}$$

MaxCPB[*tier*, *level*] and MaxBR[*tier*, *level*] are taken from Annex A of Rec. ITU-T H.265 | ISO/IEC 23008-2 for the tier and level as indicated by the temporal motion-constrained tile sets SEI message or within the parameter sets in the motion-constrained tile sets extraction information set SEI message, as specified in D.2.30 and D.2.43 respectively of Rec. ITU-T H.265 | ISO/IEC 23008-2, for the temporal motion-constrained tile set conformed by all tiles within the H substreams of the subregion. *cpb\_size* is taken from the HRD parameters, as specified in Annex E of Rec. ITU-T H.265 | ISO/IEC 23008-2, present in the parameter sets, encapsulated in the MCTS-EIS SEI message, for the temporal motion-constrained tile set conformed by all tiles within the H HEVC tile substreams of the subregion, as defined in Rec. ITU-T H.265 | ISO/IEC 23008-2.

- There is exactly one subregion buffer RB for all HEVC tile substreams identified by the list of SubstreamIDs that belong to the subregion, as shown in Figure 2-24, of which the size RBS has the following value:

$$RBS = \text{cpb\_size}_H$$

where *cpb\_size<sub>H</sub>* is the *cpb\_size* taken from the HRD parameters, as specified in Annex E of Rec. ITU-T H.265 | ISO/IEC 23008-2, present in the parameter sets, encapsulated in the MCTS-EIS SEI message, for the temporal motion-constrained tile set conformed by all tiles within the H HEVC tile substreams of the subregion, as defined in Rec. ITU-T H.265 | ISO/IEC 23008-2.

**2.17.5.4 Carriage of HEVC motion-constrained tile sets in a common ES ignoring AF descriptors**

Alternatively, a receiver might decide to ignore the AF descriptors and select the HEVC tile substreams at bitstream level following the motion-constrained tile sets extraction information sets SEI message. In such a case, the profile and level required for decoding are the ones signalled for the subregion. The size of the buffers TB, MB, EB are specified below.

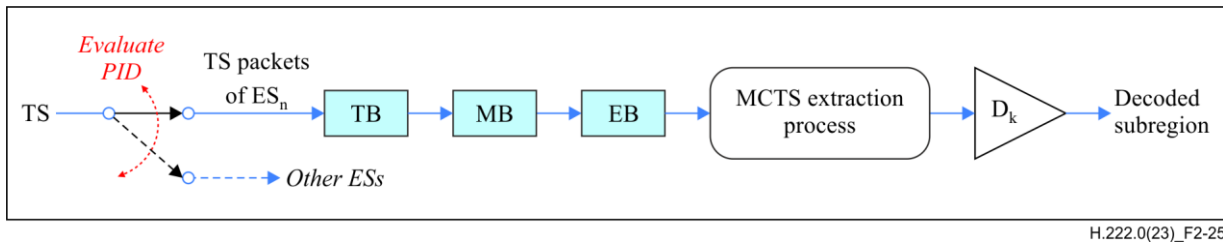

Figure 2-25 – T-STD model extension for transport of HEVC tiles in a common ES ignoring AF descriptors

**TB, MB, EB buffer management**

The following notations are used to describe the T-STD extensions and are illustrated in Figure 2-25 – T-STD model extension for transport of HEVC tiles in a common ES ignoring AF descriptors above.

- ES<sub>n</sub> is the received elementary stream that contains all HEVC tile substreams.
- TB is the transport buffer for the elementary stream that contains all HEVC tile substreams.
- TBS is the size of the transport buffer TB, measured in bytes.
- MB is the multiplex buffer for the elementary stream.
- MBS is the size of the multiplex buffer MB, measured in bytes.
- EB is the substream buffer for all the received H elementary streams of the subregion.
- EBS is the size of the substream buffer, measured in bytes.

The following applies:

- There is exactly one transport buffer TB for the received elementary stream as shown in Figure 2-25, where the size TBS is fixed to 512 bytes.
- There is exactly one multiplex buffer MB for the received elementary stream as shown in Figure 2-25, where the size of the multiplex buffer MBS is constrained as follows:

$$MBS = BS_{mux} + BS_{oh} + CpbNalFactor \times MaxCPB[tier, level] - cpb\_size \text{ (measured in bytes)}$$

where BS<sub>oh</sub>, packet overhead buffering, is defined as:

$$BS_{oh} = (1/750) \text{ seconds} \times \max\{ BrNalFactor \times MaxBR[tier, level], 2\,000\,000 \text{ bit/s} \}$$

and BS<sub>mux</sub>, additional multiplex buffering, is defined as:

$$BS_{mux} = 0.004 \text{ seconds} \times \max\{ BrNalFactor \times MaxBR[tier, level], 2\,000\,000 \text{ bit/s} \}$$

MaxCPB[tier, level] and MaxBR[tier, level] are taken from Annex A of Rec. ITU-T H.265 | ISO/IEC 23008-2 for the tier and level of the HEVC video stream or HEVC temporal video sub-bitstream. cpb\_size is taken from the HRD parameters, as specified in Annex E of Rec. ITU-T H.265 | ISO/IEC 23008-2, included in the HEVC video stream or HEVC temporal video sub-bitstream.

- There is exactly one elementary stream buffer EB for all HEVC tile substreams within the elementary stream, as shown in Figure 2-25, of which the size EBS has the following value:

$$EBS = cpb\_size$$

where cpb\_size is the cpb\_size taken from the HRD parameters, as specified in Annex E of Rec. ITU-T H.265 | ISO/IEC 23008-2, included in the HEVC video stream or the HEVC temporal video sub-bitstream.

**2.18 Carriage of green access units**

**2.18.1 Carriage of green access units in MPEG-2 sections**

Green access units are carried using the MPEG-2 private section syntax with the section\_syntax\_indicator element set to '0'. See Table 2-162.

Table 2-162 – Green access unit section syntax

Syntax	Bits	Mnemonic
Green_access_unit_section_message(){		
<b>table_ID</b>	8	<b>uimsbf</b>
<b>section_syntax_indicator</b>	1	<b>bslbf</b>
<b>private_indicator</b>	1	<b>bslbf</b>
<b>reserved</b>	2	<b>bslbf</b>
<b>private_section_length</b>	12	<b>uimsbf</b>
'0010'	4	<b>bslbf</b>
<b>Display_in_PTS [32..30]</b>	3	<b>bslbf</b>
<b>marker_bit</b>	1	<b>bslbf</b>
<b>Display_in_PTS [29..15]</b>	15	<b>bslbf</b>
<b>marker_bit</b>	1	<b>bslbf</b>
<b>Display_in_PTS [14..0]</b>	15	<b>bslbf</b>
<b>marker_bit</b>	1	<b>bslbf</b>
Green_AU()		
<b>CRC_32</b>	32	<b>rpchof</b>
}		

### 2.18.2 Semantics of green access unit section

**table\_id** – This shall be set to 0x09.

**section\_syntax\_indicator** – This shall be set to '0'.

**Display\_in\_PTS** – This is the 33-bit PTS specified similar to that defined in the PES header and is used with the associated video access unit.

**Green\_AU()** – Defined in 2.18.3.

### 2.18.3 Green access unit

The format of the green access unit is defined in Table 2-163. Green access units contain dynamic metadata and are carried in MPEG private section format.

Table 2-163 – Green access unit

Syntax	No. bits	Mnemonic
Green_AU(){		
<b>num_quality_levels</b>	4	<b>uimsbf</b>
<b>reserved</b>	4	<b>bslbf</b>
for (k=0; k < num_constant_backlight_voltage_time_intervals; k++) {		
for (j=0; j < num_max_variations; j++) {		
<b>lower_bound</b>	8	<b>uimsbf</b>
if (lower_bound > 0)		
<b>upper_bound</b>	8	<b>uimsbf</b>
<b>rgb_component_for_infinite_psnr</b>	8	<b>uimsbf</b>
for (i=1; i <= num_quality_levels; i++){		
<b>max_rgb_component</b>	8	<b>uimsbf</b>
<b>scaled_psnr_rgb</b>	8	<b>uimsbf</b>
}		
}		
}		
}		

As explained in 6.4 of ISO/IEC 23001-11, each combination of constant\_backlight\_voltage\_time\_interval and max\_variation is associated with contrast-enhancement metadata and a set of quality levels defined in Table 2-139.

The metadata in the Green\_AU is applicable to the presentation subsystem until the next Green\_AU containing metadata arrives.

Semantics for all the elements in Table 2-139 is defined in 6.4 of ISO/IEC 23001-11.

**2.18.4 Timing relationship between green access unit and media access unit**

The green access unit should be decoded and information should be available before the associated media access unit is decoded. Such a timing relationship guarantees that the metadata within the green access unit is made available to the display with sufficient lead time relative to the PTS of the associated media access unit. Note that the PTS of the media access unit and the PTS of the green access unit are identical. The green access unit is transmitted in the transport stream with a sufficient lead time so that the display control settings can be adjusted in advance of presentation time for correct operation. If  $\text{num\_constant\_backlight\_voltage\_time\_intervals} > 1$ , then the lead time should be equal to or larger than the largest  $\text{constant\_backlight\_voltage\_time\_interval}$ . The PMT shall not contain more than one green metadata component (stream\_type equal to 0x2C).

NOTE – Applications that use carouseling of green access unit data carouseling in a given program can do so as long as the display\_in\_PTS value is adjusted to conform to the PCR clock and T-STD buffer.

**2.18.5 Buffer model for processing green access units**

The buffer model reflects the processing required to handle green access units. The model can be used to establish constraints which can be used to verify the validity of dynamic green metadata prepared in accordance with this standard.

Figure 2-26 illustrates the buffer model for processing green access units.

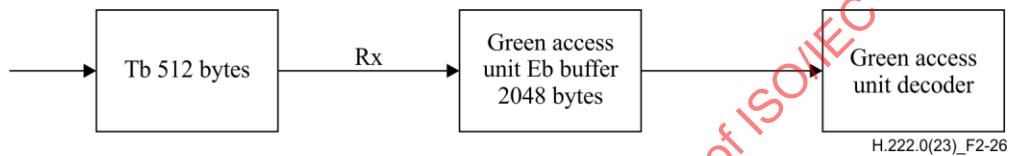

**Figure 2-26 – T-STD model extension for green access units**

MPEG-2 transport stream packets come into the model at the left, and are filtered by PID. Packets whose PID matches the green access unit PID flow into the 512 byte transport buffer. These buffered packets are removed at a rate of  $R_x = 300$  kbps (kilobits/second) and stored in the green access unit Eb buffer (2048 Bytes). Green access unit table sections are removed from the Eb buffer immediately after the full access unit is available (based on section length) and these are passed onto the green access unit decoder at a rate  $R_{bx} = 300$  kbps for decoding and each decoded access unit is associated with the video at time = display\_in\_PTS. The Eb buffer shall not overflow and the green access unit section shall be available in the Eb buffer at least 100 ms before display\_in\_PTS.

NOTE – In the worst-case, a green AU would contain 4488 bits. Under such conditions, the Eb buffer is large enough to hold up to three green AUs and the rate  $R_x$  is high enough to allow the removal of green AUs that are associated with video frames at 60 fps.

**2.19 Carriage of ISO/IEC 23008-3 MPEG-H 3D audio data**

**2.19.1 Introduction**

A Rec. ITU-T H.222.0 | ISO/IEC 13818-1 stream may carry ISO/IEC 23008-3 audio elementary streams. Typically, an ISO/IEC 23008-3 stream will be an element of a Rec. ITU-T H.222.0 | ISO/IEC 13818-1 program, as defined by the PMT in a Transport Stream and the PSM in a Program Stream.

**2.19.2 Carriage in PES packets**

Individual ISO/IEC 23008-3 elementary streams shall be carried in PES packets as PES\_packet\_data\_bytes. For PES packetization no specific data alignment constraints apply. For synchronization PTS is encoded in the header of the PES packet that carries the ISO/IEC 23008-3 elementary stream data; for PTS encoding the same constraints apply as for ISO/IEC 13818 elementary streams.

Before PES packetization the elementary stream data shall be first encapsulated in the MHAS transport syntax defined in clause 14 of ISO/IEC 23008-3. If a PTS is present in the PES packet header, it shall refer to the first mpeghAudioStreamPacket (MHAS packet) of MHASPacketType PACTYP\_MPEGH3DAFRAME that commences in the payload of the PES packet. This MHAS packet shall occur after the first MHAS packet of MHASPacketTypes PACTYP\_SYNC and PACTYPE\_MPEGH3DACFG that commences in the payload of the PES packet, if any are present. Note that additional MHAS packets of other packet types may be present between those MHAS packets (PACTYP\_SYNC, PACTYPE\_MPEGH3DACFG and PACTYP\_MPEGH3DAFRAME), e.g., PACTYP\_SYNCGAP, PACTYP\_AUDIOSCENEINFO or PACTYP\_AUDIOTRUNCATION.

It is recommended but not mandatory that in this case the first byte of the PES\_packet\_data\_bytes is the first byte of an mpegAudioStreamPacket with MHASPacketType set to PACTYP\_SYNC. In this case, the data\_alignment\_indicator in the PES packet header is set to '1'. According to 14.4.4 of ISO/IEC 23008-3, the mpegAudioStreamPacket yields an overall syncword of 0xC001A5.

To provide appropriate specific information, it is strongly recommended that each MPEG-H 3D audio stream carries audio scene information data with sufficient information to ensure that the decoded and rendered MPEG-H 3D audio stream can be presented correctly by receivers.

Carriage of ISO/IEC 23008-3 elementary streams in PES packets shall be identified by appropriate stream\_id and stream\_type values, indicating the use of ISO/IEC 23008-3 3D audio. In addition, an MPEG-H\_3dAudio\_descriptor() shall be present in the descriptor loop for the respective elementary stream entry in the Program Map Table in case of a transport stream.

### 2.19.3 STD extensions for ISO/IEC 23008-3 elementary streams

The T-STD model as defined in 2.4.2.1 includes a transport buffer  $TB_n$  and a multiplex buffer  $B_n$  prior to decoding of each ISO/IEC 23008-3 3D audio elementary stream  $n$ . For buffers  $TB_n$  and  $B_n$  and the rate  $R_{x_n}$  between  $TB_n$  and  $B_n$  the following constraints apply for the carriage of an ISO/IEC 23008-3 3D audio stream:

The size  $BS_n$  of the buffer  $B_n$ , is defined as  $BS_n = BS_{mux} + BS_{dec} + BS_{oh}$  with:

$BS_n = 3584$  bytes for 1-2 encoded audio channel signals

Here, the size of the access unit decoding buffer  $BS_{dec}$ , and the PES packet overhead buffer  $BS_{oh}$  are constrained by:  $BS_{dec} + BS_{oh} \leq 2848$  bytes; a portion (736 bytes) of the 3584 byte buffer is allocated for buffering to allow multiplexing. The rest, 2848 bytes, are shared for access unit buffering  $BS_{dec}$ ,  $BS_{oh}$  and additional multiplexing.

$BS_n = 8976$  bytes for 3-8 encoded audio channel signals

$BS_n = 12804$  bytes for 9-12 encoded audio channel signals

$BS_n = 51216$  bytes for 13-48 encoded audio channel signals

$BS_n = 136576$  bytes for 49-128 encoded audio channel signals

Rate  $R_{x_n}$ :

$R_{x_n} = 2\,000\,000$  bit/s for 1-2 encoded audio channel signals

$R_{x_n} = 5\,529\,600$  bit/s for 3-8 encoded audio channel signals

$R_{x_n} = 8\,294\,400$  bit/s for 9-12 encoded audio channel signals

$R_{x_n} = 33\,177\,600$  bit/s for 13-48 encoded audio channel signals

$R_{x_n} = 88\,473\,600$  bit/s for 49-128 encoded audio channel signals

### 2.19.4 STD extensions for multiple ISO/IEC 23008-3 elementary streams

ISO/IEC 23008-3 MPEG-H 3D audio allows encoding an audio program as several elementary streams. One single audio decoder decodes all elementary streams to one audio presentation. Each of those elementary streams carries one or more encoded audio channel signals.

For every single elementary stream the constraints for the buffer size  $BS_n$  and the rate  $R_{x_n}$  apply as described in 2.19.3 above.

As described in 14.6 of ISO/IEC 23008-3, the MHAS packets of each elementary stream are merged into one single stream before forwarding the data to the decoder. Note that based on user interactivity only a subset of the elementary streams may be merged into this single stream instead of the complete set of elementary streams.

Figure 2-27 illustrates an example of multiple elementary streams. Those streams are merged into one single intermediate stream and decoded by a single ISO/IEC 23008-3 3D audio decoder.

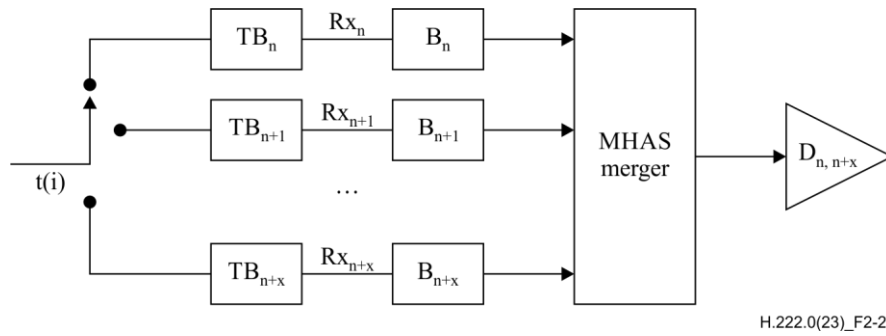

Figure 2-27 – Transport stream system target decoder for multiple audio elementary streams

In addition to the notation used and described in 2.4.2.1 to describe Figure 2-1 the following notation is used in Figure 2-27:

$D_{n,n+x}$  is the audio decoder for all x audio elementary streams n to n+x.

2.19.5 MPEG-2 Transport stream random access constraints and signalling

A TS packet containing the PES packet header of a 3D audio random access point (RAP) shall have an adaptation field. The payload\_unit\_start\_indicator bit shall be set to '1' in the TS packet header and the adaptation\_field\_control bits shall be set to '11' (as per 2.4.3.3). In addition, the random\_access\_indicator bit in the adaptation field of the TS packet that contains the PES packet header of the 3D audio RAP shall be set to '1' and follow the constraints specified in 2.4.3.5.

If the PES packet contains a RAP, then the MHAS packet of type PACTYP\_MPEGH3DAFRAME containing the RAP shall be the first MHAS packet of that type that commences in the PES packet. The audio data encapsulated in this MHAS packet shall follow the rules for a random access point as defined in 5.7 of ISO/IEC 23008-3.

2.20 Carriage of Quality Access Units in MPEG-2 sections

2.20.1 General description

Quality Access Units carrying dynamic quality metadata associated with one or more video frames, i.e., a given quality metric sample can be applicable for multiple video frames for a given DTS interval, until a new quality metric sample is declared. These access units are encapsulated in MPEG sections identified by stream\_type value of 0x2F.

Each Quality Access Unit contains configuration and timing information, as well as an array of quality values, corresponding one for one to the declared metrics. Each value is padded by preceding zero bytes, as needed, to the number of bytes indicated by field\_size\_bytes.

Quality\_access\_unit shall be carried in MPEG sections.

Every Quality Access Unit shall be a random access point.

NOTE – in order to make processing easier, each Quality Access Unit should be contained in a single TS packet.

The syntax for the Quality Access Units is provided in Table 2-164. The attribute definitions are aligned with those in ISO/IEC 23001-10.

Table 2-164 – Quality Access Unit

Syntax	No. bits	Mnemonic
Quality_Access_Unit() {		
field_size_bytes	8	uimsbf
metric_count	8	uimsbf
for ( i = 0; i < metric_count; i++) {		
metric_code	32	uimsbf
sample_count	8	uimsbf
for ( j = 0; j < sample_count; j++) {		
'0010'	4	bslbf
media_DTS [32..30]	3	uimsbf
marker_bit	1	bslbf

Table 2-164 – Quality Access Unit

Syntax	No. bits	Mnemonic
<b>media_DTS</b> [29..15]	<b>15</b>	<b>uimsbf</b>
<b>marker_bit</b>	<b>1</b>	<b>bslbf</b>
<b>media_DTS</b> [14..0]	<b>15</b>	<b>uimsbf</b>
<b>marker_bit</b>	<b>1</b>	<b>bslbf</b>
<b>quality_metric_sample</b>	<b>N</b>	<b>uimsbf</b>
}		
}		
}		

**field\_size\_bytes** – Size of the quality\_metric\_sample field. As such,  $N=8*\text{field\_size\_bytes}$

**metric\_count** – The number of metrics for quality values in the Quality Access Unit, as defined in 4.2 of ISO/IEC 23001-10.

**metric\_code** – The code name of the metrics in the Quality Access unit, as defined in 4.2 of ISO/IEC 23001-10.

**sample\_count** – Number of quality metric samples per metric.

**media\_DTS** – DTS of the media access unit described by the quality metric sample.

As such, quality\_metric\_sample is an array signalled using the 'i' and 'j' values of the loop.

**2.20.2 Buffer model for processing Quality Access Units**

The buffer model reflects processing required to handle Quality Access Units. The model can be used to establish constraints which can be used to verify the validity of dynamic Quality metadata prepared in accordance with this Standard.

Figure 2-28 illustrates the buffer model for processing Quality Access Units.

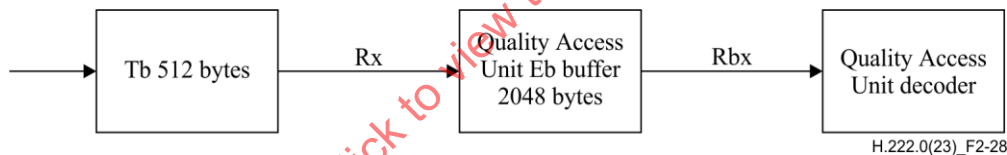

Figure 2-28 – Quality Access Unit decoder processing model

MPEG-2 Transport Stream packets come into the model at the left, and are filtered by PID. Packets whose PID matches the Quality Access Unit PID flow into the 512 byte transport buffer. These buffered packets are removed at a rate of  $R_x = 300$  kbps (kilobits/second) and stored in the Quality Access Unit Eb buffer (2048 Bytes). Quality Access Unit table sections are removed from the Eb buffer immediately after the full access unit is available (based on section length) and these are passed onto the Quality Access Unit decoder at a rate  $R_{bx} = 300$  kbps for decoding and association with the corresponding video frames. Eb buffer shall not overflow and the Quality Access Unit section shall be available in the Eb buffer to meet the requirement of DTS earlier than the DTS of the latest media access unit described in the corresponding Quality Access Unit.

**2.21 Carriage of sample variants**

**2.21.1 Introduction**

Carriage of metadata over a Rec. ITU-T H.222.0 | ISO/IEC 13818-1 stream as defined in 2.12 allows for carriage of sample variants as defined in clause 11 of ISO/IEC 23001-12:2018.

A sample variants metadata stream is associated with an audiovisual content in a Rec. ITU-T H.222.0 | ISO/IEC 13818-1 stream. There shall be only one audiovisual content stream associated with a sample variants metadata stream. There may be more than one sample variants metadata stream in a program that are associated with the same audiovisual content stream. Access to a sample variant is controlled by the protection scheme and media key and variant processing may be performed as specified in the variant processing model in clause 11.2.2 of ISO/IEC 23001-12:2018.

The decoder configuration data in the metadata descriptor of a sample variants metadata stream, as defined in clause 11.2.3 of ISO/IEC 23001-12:2018, associates the sample variants metadata stream with an audiovisual content stream.

### 2.21.2 Constraints

Sample variants shall be carried in an MPEG-2 TS metadata stream that complies with the following constraints:

1. The sample variant metadata shall be carried in a private metadata stream with `stream_id` set to 0xBD (private\_stream\_id\_1).
2. The sample variant metadata stream shall be carried in a PES stream with `stream_type` set to 0x15.
3. A `metadata_descriptor` (specified in 2.6.60) shall be used to signal the sample variants metadata stream in the PMT, in the `es_loop` for the elementary stream.
4. A four-character string, as defined in clause 11.2.3 of ISO/IEC 23001-12:2018, shall be used as the format identifier for both `metadata_format_identifier` and `metadata_application_format_identifier` in the `metadata_descriptor` to signal the sample variants metadata stream.

### 2.21.3 Sample Variants decoder configuration data

Decoding of sample variants requires the availability of decoder configuration data as defined in clause 11.2.4 of ISO/IEC 23001-12:2018. Consequently, when sample variants are carried in a Rec. ITU-T H.222.0 | ISO/IEC 13818-1 stream, then the metadata descriptor shall provide associated decoder configuration data in the same Rec. ITU-T H.222.0 | ISO/IEC 13818-1 stream and the coding of the `decoder_config_flags` shall be set to '001'.

## 2.22 Carriage of Media Orchestration Access Units

Media Orchestration Access Units shall adhere to the syntax and semantics of `timed_metadata_access_unit` (), as specified in clause 8.2.2 of ISO/IEC 23001-13.

## 2.23 Carriage of VVC

### 2.23.1 Constraints for the transport of VVC

For VVC video streams, VVC temporal video sub-bitstreams or VVC temporal video subsets, the following constraints additionally apply:

- Each VVC access unit shall contain an access unit delimiter NAL unit;

NOTE 1 – VVC requires that an access unit delimiter NAL unit is the first NAL unit within a VVC access unit. Access unit delimiter NAL units simplify the ability to detect the boundary between VVC access units.

- A VVC video stream or VVC temporal video sub-bitstream shall be an element of a Rec. ITU-T H.222.0 | ISO/IEC 13818-1 program and the `stream_type` for this elementary stream shall be equal to 0x33.
- The video parameter sets (when required), sequence parameter sets and picture parameter sets, as specified in Rec. ITU-T H.266 | ISO/IEC 23090-3, necessary for decoding a VVC video stream or VVC temporal video sub-bitstream shall be present within the elementary stream carrying that VVC video stream or VVC temporal video sub-bitstream.

NOTE 2 – A VVC video stream might not have any VPS NAL unit. In that case, the sequence parameter set refers to a video parameter set with `ID` equal to 0.

- For each VVC temporal video subset that is an element of the same Rec. ITU-T H.222.0 | ISO/IEC 13818-1 program, the `stream_type` for this elementary stream shall be equal to 0x34.
- When a Rec. ITU-T H.222.0 | ISO/IEC 13818-1 program includes more than one VVC temporal video subset, or more than one VVC temporal video sub-bitstream and at least one VVC temporal video subset, a hierarchy descriptor as defined in 2.6.7 shall be present for all associated elementary streams with `stream_type` equal to 0x32 or 0x33. The hierarchy descriptors shall be used to indicate the dependencies of all VVC temporal video sub-bitstreams and all VVC temporal video subsets.
- In each elementary stream with `stream_type` equal to 0x33 with a hierarchy descriptor the `hierarchy_type` in the hierarchy descriptor shall be equal to 15.
- In each elementary stream with `stream_type` equal to 0x34 with a hierarchy descriptor, the `hierarchy_type` in the hierarchy descriptor shall be equal to 3.
- The video parameter sets (when required), sequence parameter sets and picture parameter sets, as specified in Rec. ITU-T H.266 | ISO/IEC 23090-3, necessary for decoding the VVC highest temporal sublayer representation of a VVC temporal video subset shall be present within the elementary stream carrying the VVC temporal video sub-bitstream associated by a hierarchy descriptor.

- The aggregation of the VVC temporal video sub-bitstream with associated VVC temporal video subsets according to the hierarchy descriptors, as specified in 2.23.3, shall result in a valid VVC video stream.

NOTE 3 – The resulting VVC video stream contains a set of temporal sublayers, as specified in Rec. ITU-T H.266 | ISO/IEC 23090-3, with TemporalId values forming a contiguous range of integer numbers.

### Carriage in PES packets

Rec. ITU-T H.266 | ISO/IEC 23090-3 Video is carried in PES packets as PES\_packet\_data\_bytes, using one of the 16 stream\_id values assigned to video, while signalling the Rec. ITU-T H.266 | ISO/IEC 23090-3 video stream by means of the assigned stream-type value in the PMT (see Table 2-34). The highest level that may occur in a VVC video stream as well as a profile and tier that the entire stream conforms to should be signalled using the VVC video descriptor. If a VVC video descriptor is associated with a VVC video stream, a VVC temporal video sub-bitstream, a VVC temporal video subset, then this descriptor shall be conveyed in the descriptor loop for the respective elementary stream entry in the Program Map Table. This Recommendation | International Standard does not specify presentation of Rec. ITU-T H.266 | ISO/IEC 23090-3 streams in the context of a program.

For PES packetization, no specific data alignment constraints apply. For synchronization and STD management, PTSs and, when appropriate, DTSs are encoded in the header of the PES packet that carries the Rec. ITU-T H.266 | ISO/IEC 23090-3 video elementary stream data. For PTS and DTS encoding, the constraints and semantics apply as defined in 2.4.3.7 and 2.7.

### DPB buffer management

Carriage of a VVC video stream, a VVC temporal video sub-streams or a VVC temporal video subset over Rec. ITU-T H.222.0 | ISO/IEC 13818-1 does not impact the size of buffer DPB. For decoding of a VVC video stream, a VVC temporal video sub-bitstream or a VVC temporal video sub-bitstream and its associated VVC temporal video subsets in the STD, the size of DPB is as defined in Rec. ITU-T H.266 | ISO/IEC 23090-3. The DPB shall be managed as specified in Annex C of Rec. ITU-T H.266 | ISO/IEC 23090-3 (clauses C.3 and C.5). A decoded VVC access unit enters the DPB instantaneously upon decoding of the VVC access unit, hence at the CPB removal time of the VVC access unit. A decoded VVC access unit is presented at the DPB output time. If the VVC video stream, VVC temporal video sub-bitstream or VVC temporal video subset provides insufficient information to determine the CPB removal time and the DPB output time of VVC access units, then these time instants shall be determined in the STD model from PTS and DTS timestamps as follows:

- The CPB removal time of VVC access unit  $n$  is the instant in time indicated by  $DTS(n)$  where  $DTS(n)$  is the DTS value of VVC access unit  $n$ .
- The DPB output time of VVC access unit  $n$  is the instant in time indicated by  $PTS(n)$  where  $PTS(n)$  is the PTS value of VVC access unit  $n$ .

NOTE 4 – VVC video sequences in which the `low_delay_hrd_flag[ i ]` in the syntax structure `hrd_parameters()` is set to 1 carry sufficient information to determine the DPB output time and the CPB removal time of each VVC access unit. Hence for VVC access units for which STD underflow may occur, the CPB removal time and the DPB output time are defined by HRD parameters, and not by DTS and PTS timestamps.

NOTE 5 – A VVC video stream may carry information to determine compliance of the VVC video stream to the HRD, as specified in Annex C of Rec. ITU-T H.266 | ISO/IEC 23090-3. The presence of this information can be signalled in a transport stream using the VVC timing and HRD descriptor with the `hrd_management_valid_flag` set to '1'. Irrespective of the presence of this information, compliance of a VVC video stream to the T-STD ensures that HRD buffer management requirements for CPB are met when each byte in the VVC video stream is delivered to and removed from CPB in the HRD at exactly the same instant in time at which the byte is delivered to and removed from  $EB_n$  in the T-STD.

#### 2.23.2 T-STD Extensions for single layer VVC

When there is a VVC video stream or VVC temporal video sub-bitstream in a Rec. ITU-T H.222.0 | ISO/IEC 13818-1 program and there is no VVC temporal video subset associated with this elementary stream of stream\_type 0x33 in the same Rec. ITU-T H.222.0 | ISO/IEC 13818-1 program, the T-STD model as described in 2.4.2 is extended as illustrated in Figure 2-29 and as specified below.

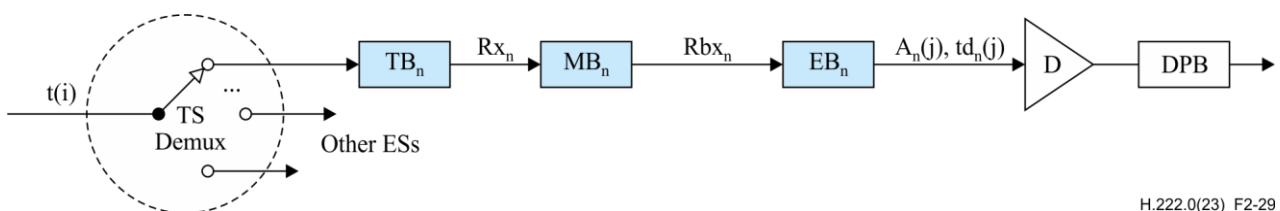

Figure 2-29 – T-STD model extensions for single layer VVC

**TB<sub>n</sub>, MB<sub>n</sub>, EB<sub>n</sub> buffer management**

The following additional notations are used to describe the T-STD extensions and are illustrated in Figure 2-29 above.

t(i) indicates the time in seconds at which the i-th byte of the Transport Stream enters the system target decoder

TB<sub>n</sub> is the transport buffer for elementary stream n

TBS is the size of the transport buffer TB<sub>n</sub>, measured in bytes

MB<sub>n</sub> is the multiplexing buffer for elementary stream n

MBS<sub>n</sub> is the size of the multiplexing buffer MB<sub>n</sub>, measured in bytes

EB<sub>n</sub> is the elementary stream buffer for the VVC video stream

j is an index to the VVC access unit of the VVC video stream

A<sub>n</sub>(j) is the j-th access unit of the VVC video bitstream

td<sub>n</sub>(j) is the decoding time of A<sub>n</sub>(j), measured in seconds, in the system target decoder

Rx<sub>n</sub> is the transfer rate from the transport buffer TB<sub>n</sub> to the multiplex buffer MB<sub>n</sub> as specified below.

Rbx<sub>n</sub> is the transfer rate from the multiplex buffer MB<sub>n</sub> to the elementary stream buffer EB<sub>n</sub> as specified below.

The following applies:

- There is exactly one transport buffer TB<sub>n</sub> for the received VVC video stream or VVC temporal video sub-bitstream where the size TBS is fixed to 512 bytes.
- There is exactly one multiplexing buffer MB<sub>n</sub> for the VVC video stream or VVC temporal video sub-bitstream, where the size MBS<sub>n</sub> of the multiplexing buffer MB is constrained as follows:

$$MBS_n = BS_{mux} + BS_{oh} + CpbNalFactor \times MaxCPB[tier, level] - cpb\_size$$

where BS<sub>oh</sub>, packet overhead buffering, is defined as:

$$BS_{oh} = (1/750) \text{ seconds} \times \max\{ BrNalFactor \times MaxBR[tier, level], 2\,000\,000 \text{ bit/s} \}$$

and BS<sub>mux</sub>, additional multiplex buffering, is defined as:

$$BS_{mux} = 0.004 \text{ seconds} \times \max\{ BrNalFactor \times MaxBR[tier, level], 2\,000\,000 \text{ bit/s} \}$$

CpbNalFactor and BrNalFactor are taken from Annex A of Rec. ITU-T H.266 | ISO/IEC 23090-3 for the profile of the VVC video stream or VVC temporal video sub-bitstream. MaxCPB[tier, level] and MaxBR[tier, level] are taken from Annex A of Rec. ITU-T H.266 | ISO/IEC 23090-3 for the tier and level of the VVC video stream or VVC temporal video sub-bitstream. cpb\_size is CpbSize[ k ][ SchedSelIdx ] corresponding to the NAL HRD parameters of data flow into the CPB for the byte stream format as specified in clause 7 of Rec. ITU-T H.266 | ISO/IEC 23090-3, included in the VVC video stream or VVC temporal video sub-bitstream, and k is the highest temporalId in the VVC video stream or VVC temporal video sub-bitstream.

- There is exactly one elementary stream buffer EB<sub>n</sub> for all the elementary streams in the set of received elementary streams associated by hierarchy descriptors, with a total size EBS<sub>n</sub>

$$EBS_n = cpb\_size \text{ (measured in bytes)}$$

where cpb\_size is CpbSize[ k ][ SchedSelIdx ] corresponding to the NAL HRD parameters of data flow into the CPB for the byte stream format as specified in clause 7 of Rec. ITU-T H.266 | ISO/IEC 23090-3, included in the VVC video stream or the VVC temporal video sub-bitstream, and k is the highest temporalId in the VVC video stream or VVC temporal video sub-bitstream.

- Transfer from TB<sub>n</sub> to MB<sub>n</sub> is applied as follows:

When there is no data in TB<sub>n</sub> then Rx<sub>n</sub> is equal to zero. Otherwise:

$$Rx_n = bit\_rate$$

where bit\_rate is BitRate[ k ][ SchedSelIdx ] corresponding to the NAL HRD parameters of data flow into the CPB for the byte stream format as defined in clause 7 of Rec. ITU-T H.266 | ISO/IEC 23090-3, and k is the highest temporalId in the VVC video stream or VVC temporal video sub-bitstream.

NOTE – When the NAL hrd\_parameters() is present in the SPS or VPS of the VVC video stream the bit\_rate is specified in sub\_layer\_hrd\_parameters( k ), with k being the highest temporalId in the VVC video stream or VVC temporal video sub-bitstream. Default values for BitRate[ k ][ SchedSelIdx ] are also specified based on profile, tier and level when NAL HRD parameters are not present in the SPS.

- Transfer from  $MB_n$  to  $EB_n$  is applied as follows:

If the `VVC_timing_and_HRD_descriptor` is present with the `hrd_management_valid_flag` set to '1' for the elementary stream, then the transfer of data from  $MB_n$  to  $EB_n$  shall follow the HRD defined scheme for data arrival in the CPB of elementary stream as defined in Annex C of Rec. ITU-T H.266 | ISO/IEC 23090-3.

Otherwise, the leak method shall be used to transfer data from  $MB_n$  to  $EB_n$  as follows:

$$Rbx_n = BrNalFactor \times MaxBR[tier, level]$$

where `BrNalFactor` is taken from Annex A of Rec. ITU-T H.266 | ISO/IEC 23090-3 for the profile of the VVC video stream or VVC temporal video sub-bitstream and `MaxBR[tier, level]` is taken from Annex A of Rec. ITU-T H.266 | ISO/IEC 23090-3 for the tier and level of the VVC video stream or VVC temporal video sub-bitstream.

If there is PES packet payload data in  $MB_n$ , and buffer  $EB_n$  is not full, the PES packet payload is transferred from  $MB_n$  to  $EB_n$  at a rate equal to  $Rbx_n$ . If  $EB_n$  is full, data are not removed from  $MB_n$ . When a byte of data is transferred from  $MB_n$  to  $EB_n$ , all PES packet header bytes that are in  $MB_n$  and precede that byte are instantaneously removed and discarded. When there is no PES packet payload data present in  $MB_n$ , no data is removed from  $MB_n$ . All data that enters  $MB_n$  leaves it. All PES packet payload data bytes enter  $EB_n$  instantaneously upon leaving  $MB_n$ .

**STD delay**

The STD delay of any Rec. ITU-T H.266 | ISO/IEC 23090-3 data other than VVC still picture data through the System Target Decoders buffers  $TB_n$ ,  $MB_n$ , and  $EB_n$  shall be constrained by  $td_n(j) - t(i) \leq 10$  seconds for all  $j$ , and all bytes  $i$  in access unit  $A_n(j)$ .

The delay of any VVC still picture data through the System Target Decoders  $TB_n$ ,  $MB_n$ , and  $EB_n$  shall be constrained by  $td_n(j) - t(i) \leq 60$  seconds for all  $j$ , and all bytes  $i$  in access unit  $A_n(j)$ .

**Buffer management conditions**

Transport streams shall be constructed so that the following conditions for buffer management are satisfied:

- Each  $TB_n$  shall not overflow and shall be empty at least once every second.
- Each  $MB_n$ ,  $EB_n$ , and DPB shall not overflow.
- $EB_n$  shall not underflow, except when HRD parameters are present for the VVC video sequence with the `low_delay_hrd_flag[ i ]` set to '1'. Underflow of  $EB_n$  occurs for VVC access unit  $A_n(j)$  when one or more bytes of  $A_n(j)$  are not present in  $EB_n$  at the decoding time  $td_n(j)$ .

**2.23.3 T-STD Extensions for layered transport of VVC temporal video subsets**

When there is a VVC video sub-bitstream and at least one associated elementary stream of type 0x34 in a Rec. ITU-T H.222.0 | ISO/IEC 13818-1 program, the T-STD model as described in 2.4.2 is extended as illustrated in Figure 2-30 and as specified below.

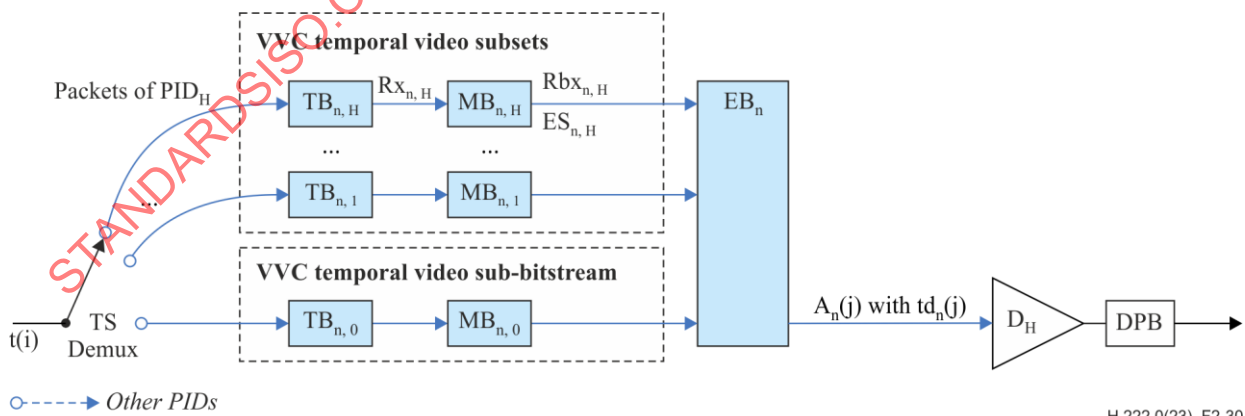

**Figure 2-30 – T-STD model extensions for layered transport of VVC temporal video subsets**

The following additional notations are used to describe the T-STD extensions and are illustrated in Figure 2-30 above.

- $t(i)$  indicates the time in seconds at which the  $i$ -th byte of the Transport Stream enters the system target decoder
- $H$  is the number of received VVC temporal video subsets, associated by hierarchy descriptors with the same VVC temporal video sub-bitstream.

- k is an index identifying the H+1 received elementary streams which contain exactly one VVC temporal video sub-bitstream and H VVC temporal video subsets associated by hierarchy descriptors. The index value k equal to 0 identifies the elementary stream which contains the VVC temporal video sub-bitstream and index values k ranging from 1 up to H identify the associated VVC temporal video subsets.
  - ES<sub>n,k</sub> is the received elementary stream which contains the k-th VVC temporal video subset or the VVC temporal video sub-bitstream if k equals 0
  - ES<sub>n,H</sub> is the received elementary stream containing the highest VVC temporal video subset present in the set of received elementary streams
  - PID<sub>H</sub> is the packet identifier value which identifies ES<sub>n,H</sub>
  - j is an index to the output access units
  - A<sub>n(j)</sub> is the j-th access unit of the VVC complete temporal representation
  - td<sub>n(j)</sub> is the decoding time of A<sub>n(j)</sub> in the system target decoder
  - TB<sub>n,k</sub> is the transport buffer for elementary stream k
  - TBS<sub>n,k</sub> is the size of the transport buffer TB<sub>n,k</sub>, measured in bytes
  - MB<sub>n,k</sub> is the multiplexing buffer for elementary stream k
  - MBS<sub>n,k</sub> is the size of the multiplexing buffer MB<sub>n,k</sub>, measured in bytes
  - EB<sub>n</sub> is the elementary stream buffer for the received VVC temporal video sub-bitstream ES<sub>n,0</sub> and the received VVC temporal video subsets ES<sub>n,1</sub> to ES<sub>n,H</sub>
  - EBS<sub>n</sub> is the size of elementary stream buffer EB<sub>n</sub>, measured in bytes
  - Rx<sub>n,k</sub> is the transfer rate from the k-th transport buffer TB<sub>n,k</sub> to the k-th multiplex buffer MB<sub>n,k</sub> as specified below
  - Rbx<sub>n,k</sub> is the transfer rate from the k-th multiplex buffer MB<sub>n,k</sub> to the elementary stream buffer EB<sub>n</sub> as specified below
- NOTE – The index n, where used, indicates that the received elementary streams and associated buffers belong to a certain VVC temporal video sub-bitstream and its associated VVC temporal video subsets, distinguishing these elementary streams and associated buffers from other elementary streams and buffers, maintaining consistency with the notation in Figure 2-29.

**TB<sub>n,k</sub>, MB<sub>n,k</sub>, EB<sub>n</sub> buffer management**

The following applies:

- There is one transport buffer TB<sub>n,k</sub> for each received elementary stream ES<sub>n,k</sub>, where the size TBS<sub>n,k</sub> is fixed to 512 bytes.
- There is one multiplex buffer MB<sub>n,k</sub> for each received elementary stream ES<sub>n,k</sub>, where the size MBS<sub>n,k</sub> of the multiplex buffer MB<sub>n,k</sub> is constrained as follows:

$$MBS_{n,k} = BS_{mux} + BS_{oh} + CpbNalFactor \times MaxCPB[tier, level] - cpb\_size \text{ (measured in bytes)}$$

where

BS<sub>oh</sub>, packet overhead buffering, and BS<sub>mux</sub>, additional multiplex buffering, are as specified in 2.23.2;

CpbNalFactor and BrNalFactor are taken from Annex A of Rec. ITU-T H.266 | ISO/IEC 23090-3 for the profile of the VVC video stream. MaxCPB[tier, level] and MaxBR[tier, level] are taken from Annex A of Rec. ITU-T H.266 | ISO/IEC 23090-3 for the tier and level of the VVC highest temporal sublayer representation associated with ES<sub>n,k</sub>;

cpb\_size is CpbSize[ k ][ SchedSelIdx ] corresponding to the NAL HRD parameters of data flow into the CPB for the byte stream format as specified in Rec. ITU-T H.266 | ISO/IEC 23090-3, included in the VVC highest temporal sublayer representation associated with ES<sub>n,k</sub> and k is the highest temporalId in the VVC highest temporal sublayer representation associated with ES<sub>n,k</sub>.

- There is exactly one elementary stream buffer EB<sub>n</sub> for the H + 1 elementary streams in the set of received elementary streams ES<sub>n,0</sub> to ES<sub>n,H</sub>, with a total size EBS<sub>n</sub>

$$EBS_n = cpb\_size \text{ (measured in bytes)}$$

where cpb\_size is CpbSize[ k ][ SchedSelIdx ] corresponding to the NAL HRD parameters of data flow into the CPB for the byte stream format as specified in Rec. ITU-T H.266 | ISO/IEC 23090-3, included in the VVC highest temporal sublayer representation associated with ES<sub>n,H</sub> and k is the highest temporalId in the VVC highest temporal sublayer representation associated with ES<sub>n,H</sub>.

- Transfer from  $TB_{n,k}$  to  $MB_{n,k}$  is applied as follows:

When there is no data in  $TB_{n,k}$  then  $R_{x_{n,k}}$  is equal to zero. Otherwise:

$$R_{x_{n,k}} = \text{bit\_rate}$$

where  $\text{bit\_rate}$  is  $\text{BitRate}[k][\text{SchedSelIdx}]$  corresponding to the NAL HRD parameters of data flow into the CPB for the byte stream format as defined in clause 7 of Rec. ITU-T H.266 | ISO/IEC 23090-3, included in the VVC highest temporal sublayer representation associated with  $ES_{n,k}$  and  $k$  is the highest temporalId in the VVC highest temporal sublayer representation associated with  $ES_{n,k}$ .

- Transfer from  $MB_{n,k}$  to  $EB_n$  is applied as follows:

If the  $VVC\_timing\_and\_HRD\_descriptor$  is present with the  $hrd\_management\_valid\_flag$  set to '1' for the VVC video sub-bitstream, then the transfer of data from  $MB_{n,k}$  to  $EB_n$  shall follow the HRD defined scheme for data arrival in the CPB of elementary stream  $ES_{n,H}$  as defined in Annex C of Rec. ITU-T H.266 | ISO/IEC 23090-3.

Otherwise, the leak method shall be used to transfer data from  $MB_{n,k}$  to  $EB_n$  as follows:

$$R_{b_{x_{n,k}}} = \text{BrNalFactor} \times \text{MaxBR}[\text{tier}, \text{level}]$$

where  $\text{BrNalFactor}$  is taken from Annex A of Rec. ITU-T H.266 | ISO/IEC 23090-3 for the profile of the VVC video stream and  $\text{MaxBR}[\text{tier}, \text{level}]$  is defined for the byte stream format in Annex A of Rec. ITU-T H.266 | ISO/IEC 23090-3 for the tier and level of the VVC video stream or the VVC highest temporal sublayer representation associated with  $ES_{n,H}$ .

If there is PES packet payload data in  $MB_{n,k}$ , and  $EB_n$  is not full, the PES packet payload is transferred from  $MB_{n,k}$  to  $EB_n$  at a rate equal to  $R_{b_{x_{n,k}}}$ . If  $EB_n$  is full, data are not removed from  $MB_{n,k}$ . When a byte of data is transferred from  $MB_{n,k}$  to  $EB_n$ , all PES packet header bytes that are in  $MB_{n,k}$  and precede that byte are instantaneously removed and discarded. When there is no PES packet payload data present in  $MB_{n,k}$ , no data is removed from  $MB_{n,k}$ . All data that enters  $MB_{n,k}$  leaves it. All PES packet payload data bytes enter  $EB_n$  instantaneously upon leaving  $MB_{n,k}$ .

At the output of the elementary stream buffer  $EB_n$ , the elementary streams are aggregated by removing all VVC access units in ascending DTS order and transferring them to the VVC decoder  $D_H$ , irrespective of which elementary stream  $ES_{n,k}$  each VVC access unit belongs to.

### STD delay

The STD delay of any Rec. ITU-T H.266 | ISO/IEC 23090-3 data other than VVC still picture data through the System Target Decoders buffers  $TB_{n,k}$ ,  $MB_{n,k}$ , and  $EB_n$  shall be constrained by  $t_{d_n(j)} - t(i) \leq 10$  seconds for all  $k$ , all  $j$ , and all bytes  $i$  in access unit  $A_n(j)$ .

The delay of any VVC still picture data through the System Target Decoders  $TB_{n,k}$ ,  $MB_{n,k}$ , and  $EB_n$  shall be constrained by  $t_{d_n(j)} - t(i) \leq 60$  seconds for all  $k$ , all  $j$ , and all bytes  $i$  in access unit  $A_n(j)$ .

### Buffer management conditions

Transport streams shall be constructed so that the following conditions for buffer management are satisfied:

- Each  $TB_{n,k}$  shall not overflow and shall be empty at least once every second.
- Each  $MB_{n,k}$ ,  $EB_n$ , and DPB shall not overflow.
- $EB_n$  shall not underflow, except when HRD parameters are present for the VVC video sequence with the  $\text{low\_delay\_hrd\_flag}[i]$  set to '1'. Underflow of  $EB_n$  occurs for VVC access unit  $A_n(j)$  when one or more bytes of  $A_n(j)$  are not present in  $EB_n$  at the decoding time  $t_{d_n(j)}$ .

## 2.24 Carriage of EVC

### 2.24.1 Constraints for the transport of EVC

For EVC video streams or EVC temporal video sub-bitstreams, the following constraints additionally apply:

- Each EVC access unit shall contain an access unit delimiter NAL unit;

NOTE 1 – EVC requires that an access unit delimiter NAL unit is the first NAL unit within an EVC access unit. Access unit delimiter NAL units simplify the ability to detect the boundary between EVC access units.

- An EVC video stream or EVC temporal video sub-bitstream shall be an element of a Rec. ITU-T H.222.0 | ISO/IEC 13818-1 program and the  $\text{stream\_type}$  for this elementary stream shall be equal to 0x35.
- The sequence parameter sets, picture parameter sets and adaptation parameter sets, as specified in ISO/IEC 23094-1, necessary for decoding an EVC video stream or EVC temporal video sub-bitstream shall be

present within the elementary stream carrying that EVC video stream or EVC temporal video sub-bitstream.

- In each elementary stream with stream\_type equal to 0x35 with a hierarchy descriptor the hierarchy\_type in the hierarchy descriptor shall be equal to 16.

**Carriage in PES packets**

ISO/IEC 23094-1 Video is carried in PES packets as PES\_packet\_data\_bytes, using one of the 16 stream\_id values assigned to video, while signalling the ISO/IEC 23094-1 video stream by means of the assigned stream-type value in the PMT (see Table 2-34). The highest level that may occur in an EVC video stream as well as profile and toolset identifications that the entire stream conforms to should be signalled using the EVC video descriptor. If an EVC video descriptor is associated with an EVC video stream or an EVC temporal video sub-bitstream, then this descriptor shall be conveyed in the descriptor loop for the respective elementary stream entry in the Program Map Table. This Recommendation | International Standard does not specify presentation of ISO/IEC 23094-1 streams in the context of a program.

Every EVC access unit shall be carried on exactly one PES packet. For PES packetization, no specific data alignment constraints apply. For synchronization and STD management, PTSs and, when appropriate, DTSs are encoded in the header of the PES packet that carries the ISO/IEC 23094-1 video elementary stream data. For PTS and DTS encoding, the constraints and semantics apply as defined in 2.4.3.7 and 2.7.

NOTE 2 – EVC video streams can emulate PES start codes (in contrast to other video codecs that mandate start code emulation prevention for the elementary stream).

**DPB buffer management**

Carriage of a EVC video stream or a EVC temporal video sub-streams over Rec. ITU-T H.222.0 | ISO/IEC 13818-1 does not impact the size of buffer DPB. The DPB shall be managed as specified in Annex C of ISO/IEC 23094-1 (clauses C.3 and C.5). A decoded EVC access unit enters the DPB instantaneously upon decoding of the EVC access unit, hence at the CPB removal time of the EVC access unit. A decoded EVC access unit is presented at the DPB output time. If the EVC video stream or an EVC temporal video sub-bitstream provides insufficient information to determine the CPB removal time and the DPB output time of EVC access units, then these time instants shall be determined in the STD model from PTS and DTS timestamps as follows:

- 1) The CPB removal time of EVC access unit n is the instant in time indicated by DTS(n) where DTS(n) is the DTS value of EVC access unit n.
- 2) The DPB output time of EVC access unit n is the instant in time indicated by PTS(n) where PTS(n) is the PTS value of EVC access unit n.

NOTE 3 – EVC video sequences in which the low\_delay\_hrd\_flag in the syntax structure hrd\_parameters() is set to 1 carry sufficient information to determine the DPB output time and the CPB removal time of each EVC access unit. Hence for EVC access units for which STD underflow may occur, the CPB removal time and the DPB output time are defined by HRD parameters, and not by DTS and PTS timestamps.

NOTE 4 – An EVC video stream may carry information to determine compliance of the EVC video stream to the HRD, as specified in Annex C of ISO/IEC 23094-1. The presence of this information can be signalled in a transport stream using the EVC timing and HRD descriptor with the hrd\_management\_valid\_flag set to '1'. Irrespective of the presence of this information, compliance of a EVC video stream to the T-STD ensures that HRD buffer management requirements for CPB are met when each byte in the EVC video stream is delivered to and removed from CPB in the HRD at exactly the same instant in time at which the byte is delivered to and removed from EB<sub>n</sub> in the T-STD.

**2.24.2 T-STD Extensions for single layer EVC**

When there is a EVC video stream or EVC temporal video sub-bitstream in a Rec. ITU-T H.222.0 | ISO/IEC 13818-1 program, the T-STD model as described in 2.4.2 is extended as illustrated in Figure 2-31 and as specified below.

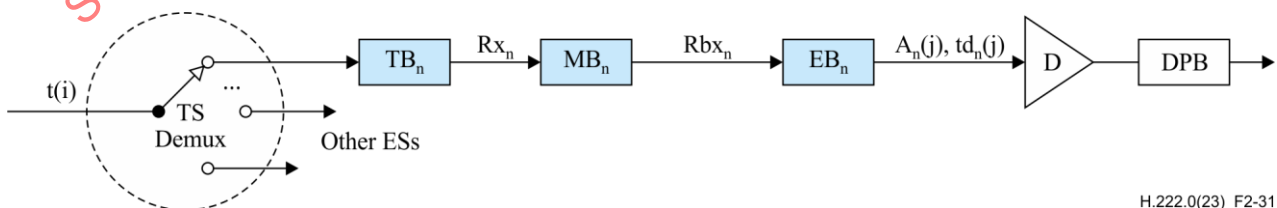

**Figure 2-31 – T-STD model extensions for single layer EVC**

H.222.0(23)\_F2-31

**TB<sub>n</sub>, MB<sub>n</sub>, EB<sub>n</sub> buffer management**

The following additional notations are used to describe the T-STD extensions and are illustrated in Figure 2-31.

t(i) indicates the time in seconds at which the i-th byte of the Transport Stream enters the system target decoder

TB<sub>n</sub> is the transport buffer for elementary stream n

TBS is the size of the transport buffer TB<sub>n</sub>, measured in bytes

MB<sub>n</sub> is the multiplexing buffer for elementary stream n

MBS<sub>n</sub> is the size of the multiplexing buffer MB<sub>n</sub>, measured in bytes

EB<sub>n</sub> is the elementary stream buffer for the EVC video stream

j is an index to the EVC access unit of the EVC video stream

A<sub>n</sub>(j) is the j-th access unit of the EVC video bitstream

td<sub>n</sub>(j) is the decoding time of A<sub>n</sub>(j), measured in seconds, in the system target decoder

Rx<sub>n</sub> is the transfer rate from the transport buffer TB<sub>n</sub> to the multiplex buffer MB<sub>n</sub> as specified below.

Rbx<sub>n</sub> is the transfer rate from the multiplex buffer MB<sub>n</sub> to the elementary stream buffer EB<sub>n</sub> as specified below.

The following applies:

- There is exactly one transport buffer TB<sub>n</sub> for the received EVC video stream or EVC temporal video sub-bitstream where the size TBS is fixed to 512 bytes.
- There is exactly one multiplexing buffer MB<sub>n</sub> for the EVC video stream or EVC temporal video sub-bitstream, where the size MBS<sub>n</sub> of the multiplexing buffer MB is constrained as follows:

$$MBS_n = BS_{mux} + BS_{oh} + CpbBrNalFactor \times MaxCPB[level] \times cpb\_size$$

where BS<sub>oh</sub>, packet overhead buffering, is defined as:

$$BS_{oh} = (1/750) \text{ seconds} \times \max\{ CpbBrNalFactor \times MaxBR[level], 2\,000\,000 \text{ bit/s} \}$$

and BS<sub>mux</sub>, additional multiplex buffering, is defined as:

$$BS_{mux} = 0.004 \text{ seconds} \times \max\{ CpbBrNalFactor \times MaxBR[level], 2\,000\,000 \text{ bit/s} \}$$

MaxCPB [level] and MaxBR[level] are taken from Annex A of ISO/IEC 23094-1 for the level of the EVC video stream or EVC temporal video sub-bitstream. cpb\_size is taken from the HRD parameters cpb\_size\_value\_minus1 [ SchedSelIdx ], as specified in Annex E of ISO/IEC 23094-1, included in the EVC video stream or EVC temporal video sub-bitstream.

- There is exactly one elementary stream buffer EB<sub>n</sub> for all the elementary streams in the set of received elementary streams associated by hierarchy descriptors, with a total size EBS<sub>n</sub>

$$EBS_n = cpb\_size \text{ (measured in bytes)}$$

where cpb\_size is taken from the HRD parameters, as specified in clause 7 of ISO/IEC 23094-1, included in the EVC video stream or the EVC temporal video sub-bitstream.

- Transfer from TB<sub>n</sub> to MB<sub>n</sub> is applied as follows:

When there is no data in TB<sub>n</sub> then Rx<sub>n</sub> is equal to zero. Otherwise:

$$Rx_n = bit\_rate$$

where bit\_rate is bit\_rate\_value\_minus1 [ SchedSelIdx ] + 1 corresponding to the NAL HRD parameters of data flow into the CPB for the byte stream format and bit\_rate\_value\_minus1 [ SchedSelIdx ] is as defined in Annex E of ISO/IEC 23094-1.

NOTE – When the NAL hrd\_parameters() is present in the SPS of the EVC video stream the bit\_rate is specified in sub\_layer\_hrd\_parameters( i ). Default values for bit\_rate\_value\_minus1 [ SchedSelIdx ] are also specified based on profile, tier and level when NAL HRD parameters are not present in the SPS. .

- Transfer from MB<sub>n</sub> to EB<sub>n</sub> is applied as follows:

If the EVC\_timing\_and\_HRD\_descriptor is present with the hrd\_management\_valid\_flag set to '1' for the elementary stream, then the transfer of data from MB<sub>n</sub> to EB<sub>n</sub> shall follow the HRD defined scheme for data arrival in the CPB of elementary stream as defined in Annex C of ISO/IEC 23094-1.

Otherwise, the leak method shall be used to transfer data from MB<sub>n</sub> to EB<sub>n</sub> as follows:

$$Rb_{x_n} = CpbBrNalFactor \times MaxBR[level]$$

where  $MaxBR[level]$  is taken from Annex A of ISO/IEC 23094-1 for the tier and level of the EVC video stream or EVC temporal video sub-bitstream.

If there is PES packet payload data in  $MB_n$ , and buffer  $EB_n$  is not full, the PES packet payload is transferred from  $MB_n$  to  $EB_n$  at a rate equal to  $Rb_{x_n}$ . If  $EB_n$  is full, data are not removed from  $MB_n$ . When a byte of data is transferred from  $MB_n$  to  $EB_n$ , all PES packet header bytes that are in  $MB_n$  and precede that byte are instantaneously removed and discarded. When there is no PES packet payload data present in  $MB_n$ , no data is removed from  $MB_n$ . All data that enters  $MB_n$  leaves it. All PES packet payload data bytes enter  $EB_n$  instantaneously upon leaving  $MB_n$ .

### STD delay

The STD delay of any ISO/IEC 23094-1 data other than EVC still picture data through the System Target Decoders buffers  $TB_n$ ,  $MB_n$ , and  $EB_n$  shall be constrained by  $td_n(j) - t(i) \leq 10$  seconds for all  $j$ , and all bytes  $i$  in access unit  $A_n(j)$ .

The delay of any EVC still picture data through the System Target Decoders  $TB_n$ ,  $MB_n$ , and  $EB_n$  shall be constrained by  $td_n(j) - t(i) \leq 60$  seconds for all  $j$ , and all bytes  $i$  in access unit  $A_n(j)$ .

### Buffer management conditions

Transport streams shall be constructed so that the following conditions for buffer management are satisfied:

- Each  $TB_n$  shall not overflow and shall be empty at least once every second.
- Each  $MB_n$ ,  $EB_n$ , and  $DPB$  shall not overflow.
- $EB_n$  shall not underflow, except when HRD parameters are present for the EVC video sequence with the `low_delay_hrd_flag` set to '1'. Underflow of  $EB_n$  occurs for EVC access unit  $A_n(j)$  when one or more bytes of  $A_n(j)$  are not present in  $EB_n$  at the decoding time  $td_n(j)$ .

## 2.25 Carriage of LCEVC

### 2.25.1 Constraints for the transport of LCEVC

For LCEVC video streams, the following constraints additionally apply:

- An LCEVC video stream shall be an element of an Rec. ITU-T H.222.0 | ISO/IEC 13818-1 program and the `stream_type` for this elementary stream shall be equal to the value defined in Table 2-34.
- A Rec. ITU-T H.222.0 | ISO/IEC 13818-1 program may include more than one LCEVC video stream.
- Each LCEVC video stream in a Rec. ITU-T H.222.0 | ISO/IEC 13818-1 program shall have an LCEVC video descriptor present in the descriptor loop of the program map section for the LCEVC video stream.
- It is possible that the same video elementary stream constitutes a base stream for more than one LCEVC video stream.
- For each LCEVC video stream in a Rec. ITU-T H.222.0 | ISO/IEC 13818-1 program, a video elementary stream in the same Rec. ITU-T H.222.0 | ISO/IEC 13818-1 program shall exist with an LCEVC linkage descriptor and the array of `lcevc_stream_tags` of this LCEVC linkage descriptor shall include one with the same value of `lcevc_stream_tag` of the LCEVC video descriptor of this LCEVC video stream.
- An LCEVC video stream enhances the base video elementary stream, element of the same Rec. ITU-T H.222.0 | ISO/IEC 13818-1 program, that carries the same `lcevc_stream_tag`, in its LCEVC linkage descriptor, as the `lcevc_stream_tag` indicated in the LCEVC video descriptor.
- The NAL units, as specified in ISO/IEC 23094-2, necessary for decoding an LCEVC video stream, shall be present within the elementary stream carrying that LCEVC video stream.

### 2.25.2 Carriage in PES packets

ISO/IEC 23094-2 video is carried in PES packets as `PES_packet_data_bytes`, using one of the 16 `stream_id` values assigned to video, while signalling the ISO/IEC 23094-2 video stream by means of the assigned stream-type value in the PMT (see Table 2-34). The highest level that may occur in an LCEVC video stream as well as a profile and tier that the entire stream conforms to should be signalled using the LCEVC video descriptor. If an LCEVC video descriptor is associated with an LCEVC video stream, then this descriptor shall be conveyed in the descriptor loop for the respective elementary stream entry in the program map table.

This Recommendation | International Standard does not specify the presentation of ISO/IEC 23094-2 streams in the context of a program.

For PES packetization, the following data alignment constraints apply:

- Only one access unit shall be carried within each PES packet.
- PES\_packet\_length of value 0 is allowed and shall indicate to the decoder that it should detect PES boundaries by means of the payload\_unit\_start\_indicator.

For synchronization and STD management, PTSs shall be encoded in the header of each PES packet that carries the ISO/IEC 23094-2 video elementary stream data. For PTS encoding, the constraints and semantics apply as defined in 2.4.3.7 and 2.7.

### 2.25.3 DPB buffer management

Carriage of a LCEVC video stream over Rec. ITU-T H.222.0 | ISO/IEC 13818-1 does not impact the size of buffer DPB. For decoding of a LCEVC video stream in the STD, the size of DPB is as defined in ISO/IEC 23094-2. The DPB shall be managed as specified in Annex C of ISO/IEC 23094-2 (clauses C.3 and C.5). A decoded LCEVC access unit enters the DPB instantaneously upon decoding of the LCEVC access unit, hence at the CPB removal time of the LCEVC access unit. A decoded LCEVC access unit is presented at the DPB output time. If the base video stream provides insufficient information to determine the CPB removal time and the DPB output time of LCEVC access units, then these time instants shall be determined in the STD model from PTS and DTS timestamps as follows:

- The CPB removal time of LCEVC access unit  $n$  is the instant in time indicated by  $DTS(n)$ , where  $DTS(n)$  is the DTS value of base access unit  $n$ .
- The DPB output time of LCEVC access unit  $n$  is the instant in time indicated by  $PTS(n)$ , where  $PTS(n)$  is the PTS value of base access unit  $n$ .

NOTE 1 – LCEVC video sequences in which the low\_delay\_hrd\_flag in the syntax structure hrd\_parameters() on the base stream is set to 1 carry sufficient information to determine the DPB output time and the CPB removal time of each LCEVC access unit. Hence, for base access units for which STD underflow can occur, the CPB removal time and the DPB output time are defined by HRD parameters, and not by DTS and PTS timestamps.

NOTE 2 – An LCEVC video stream may carry information to determine compliance of the LCEVC video stream to the HRD, as specified in Annex C of ISO/IEC 23094-2. The presence of this information can be signalled in a transport stream using the base timing and HRD descriptor with the hrd\_management\_valid\_flag set to '1'. Irrespective of the presence of this information, compliance of a base video stream to the T-STD ensures that HRD buffer management requirements for CPB are met when each byte in the LCEVC video stream is delivered to and removed from CPB in the HRD at exactly the same instant in time at which the byte is delivered to and removed from  $EB_n$  in the T-STD.

Annex A

CRC decoder model

(This annex forms an integral part of this Recommendation | International Standard.)

A.1 CRC decoder model

The 32-bit CRC decoder model is specified in Figure A.1.

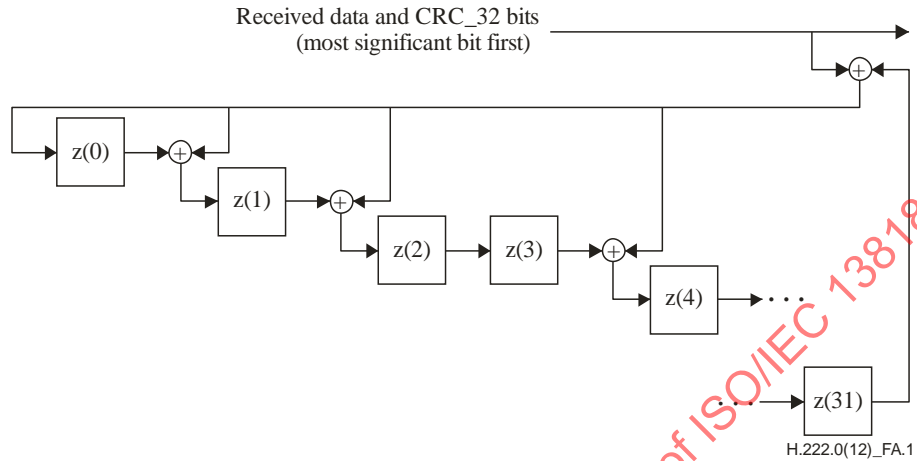

Figure A.1 – 32-bit CRC decoder model

The 32-bit CRC decoder operates at bit level and consists of 14 adders '+' and 32 delay elements z(i). The input of the CRC decoder is added to the output of z(31), and the result is provided to the input z(0) and to one of the inputs of each remaining adder. The other input of each remaining adder is the output of z(i), while the output of each remaining adder is connected to the input of z(i + 1), with i = 0, 1, 3, 4, 6, 7, 9, 10, 11, 15, 21, 22, and 25. Refer to Figure A.1.

This is the CRC calculated with the polynomial:

$$x^{32} + x^{26} + x^{23} + x^{22} + x^{16} + x^{12} + x^{11} + x^{10} + x^8 + x^7 + x^5 + x^4 + x^2 + x + 1 \tag{A-1}$$

Bytes are received at the input of the CRC decoder. Each byte is shifted into the CRC decoder one bit at a time, with the left most bit (msb) first. For example, if the input is byte 0x01 the seven '0's enter the CRC decoder first, followed by the one '1'. Before the CRC processing of the data of a section the output of each delay element z(i) is set to its initial value '1'. After this initialization, each byte of the section is provided to the input of the CRC decoder, including the four CRC\_32 bytes. After shifting the last bit of the last CRC\_32 byte into the decoder, i.e., into z(0) after the addition with the output of z(31), the output of all delay elements z(i) is read. In the case where there are no errors, each of the outputs of z(i) shall be zero. At the CRC encoder the CRC\_32 field is encoded with a value such that this is ensured.

## Annex B

### Digital storage medium command and control (DSM-CC)

(This annex does not form an integral part of this Recommendation | International Standard.)

#### B.1 Introduction

The DSM-CC protocol is a specific application protocol intended to provide the basic control functions and operations specific to managing a Rec. ITU-T H.222.0 | ISO/IEC 13818-1 bitstream on digital storage media. This DSM-CC is a low-level protocol above network/OS layers and below application layers.

The DSM-CC shall be transparent in the following sense:

- It is independent of the DSM used;
- it is independent of whether the DSM is located at a local or remote site;
- it is independent of the network protocol with which the DSM-CC is interfaced;
- it is independent of the various operating systems on which the DSM is operated.

#### B.1.1 Purpose

Many applications of Rec. ITU-T H.222.0 | ISO/IEC 13818-1 DSM Control Commands require access to a Rec. ITU-T H.222.0 | ISO/IEC 13818-1 bitstream stored on a variety of digital storage media at a local or remote site. Different DSM have their own specific control commands and thus, a user would need to know different sets of specific DSM control commands in order to access Rec. ITU-T H.222.0 | ISO/IEC 13818-1 bitstreams from different DSM. This brings many difficulties to the interface design of a Rec. ITU-T H.222.0 | ISO/IEC 13818-1 or ISO/IEC 11172-1 application system. To overcome this difficulty, a set of common DSM control commands, which is independent of the specific DSM used, is suggested in this annex. This annex is informative only. ISO/IEC 13818-6 defines DSM-CC extension with a broader scope.

#### B.1.2 Future applications

Beyond the immediate applications supported by the current DSM control commands, future applications based on extensions of DSM command control could include the following:

##### Video on demand

Video programs are provided as requested by a customer through various communication channels. The customer could select a video program from a list of programs available from a video server. Such applications could be used by hotels, cable TV, educational institutions, hospitals, etc.

##### Interactive video services

In these applications, the user provides frequent feedback controlling the manipulation of stored video and audio. These services can include video-based games, user-controlled video tours, electronic shopping, etc.

##### Video networks

Various applications may wish to exchange stored audio and video data through some type of computer network. Users could route AV information through the video network to their terminals. Electronic publishing and multimedia applications are examples of this kind of application.

#### B.1.3 Benefits

Specifying the DSM control commands independent of the DSM, end-users can perform Rec. ITU-T H.222.0 | ISO/IEC 13818-1 decoding without having to fully understand the detailed operation of the specific DSM used.

The DSM control commands are codes to give end users the assurance that the Rec. ITU-T H.222.0 | ISO/IEC 13818-1 bitstreams can be played and stored with the same semantics, independent of the DSM and user interface. They are fundamental commands for the control of DSM operation.

## ISO/IEC 13818-1:2023

### B.1.4 Basic functions

#### B.1.4.1 Stream selection

The DSM-CC provides the means to select a Rec. ITU-T H.222.0 | ISO/IEC 13818-1 bitstream upon which to perform the succeeding operations. Such operations include creation of a new bitstream. Parameters of this function include:

- index of the Rec. ITU-T H.222.0 | ISO/IEC 13818-1 bitstream (the mapping between this index and a name meaningful to an application is outside the scope of the current DSM-CC);
- mode (retrieval/storage).

#### B.1.4.2 Retrieval

The DSM-CC provides the means to:

- play an identified Rec. ITU-T H.222.0 | ISO/IEC 13818-1 bitstream;
- play from a given presentation time;
- set the playback speed (normal or fast);
- set the playback duration (until a specified presentation time, the end of the bitstream in forward play or the beginning in reverse play or the issuance of a stop command);
- set the direction (forward or reverse);
- pause;
- resume;
- change the access point in the bitstream;
- stop.

#### B.1.4.3 Storage

The DSM-CC provides the means to:

- cause storage of a valid bitstream for a specified duration;
- cause storage to stop.

DSM-CC provides a useful but limited subset of functionality that may be required in DSM based Rec. ITU-T H.222.0 | ISO/IEC 13818-1 applications. It is fully expected that significant additional capabilities will be added through subsequent extensions.

## B.2 General elements

### B.2.1 Scope

The scope of this work consists of the development of a Recommendation | International Standard to specify a useful set of commands for control of digital storage media on which a Rec. ITU-T H.222.0 | ISO/IEC 13818-1 bitstream is stored. The commands can perform remote control of a digital storage media in a general way independently of the specific DSM and apply to any Rec. ITU-T H.222.0 | ISO/IEC 13818-1 bitstream stored on a DSM.

### B.2.2 Overview of the DSM-CC application

The current DSM-CC syntax and semantics cover the single user to DSM application. The user's system is capable of retrieving a Rec. ITU-T H.222.0 | ISO/IEC 13818-1 bitstream and is also (optionally) capable of generating a Rec. ITU-T H.222.0 | ISO/IEC 13818-1 bitstream. The control channel over which the DSM commands and acknowledgements are sent is shown in Figure B.1 as an out-of-band channel. This can also be accomplished by inserting the DSM-CC commands and acknowledgements into the Rec. ITU-T H.222.0 | ISO/IEC 13818-1 bitstreams if an out-of-band channel is not available.

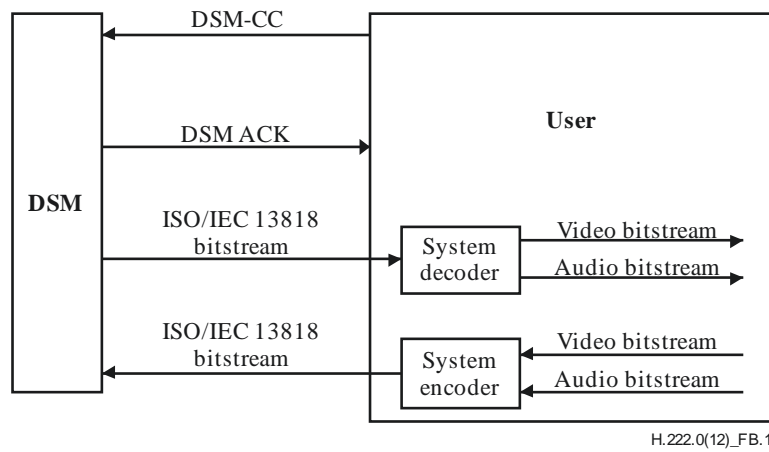
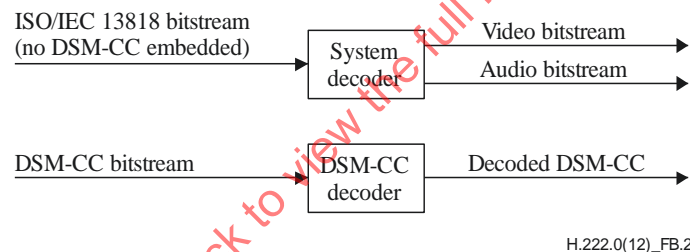

**Figure B.1 – Configuration of DSM-CC application**

**B.2.3 The transmission of DSM-CC commands and acknowledgements**

The DSM-CC is encoded into a DSM-CC bitstream according to the syntax and semantics defined in B.3.2 through B.3.9. The DSM-CC bitstream can be transmitted both as a stand-alone bitstream and in a Rec. ITU-T H.222.0 | ISO/IEC 13818-1 Systems bitstream.

When the DSM-CC bitstream is transmitted in stand-alone mode, its relationship to the Systems bitstream and the decoding process is illustrated in Figure B.2. In this case, the DSM-CC bitstream is not embedded in the Systems bitstream. This transmission mode can be used in the applications when the DSM is connected directly with the Rec. ITU-T H.222.0 | ISO/IEC 13818-1 decoder. It can also be used in the applications where the DSM-CC bitstream could be controlled and transmitted by other types of network multiplexors.



**Figure B.2 – BSM-CC bitstream decoded as a stand-alone bitstream**

For some applications, it is desirable to transmit the DSM-CC in a Rec. ITU-T H.222.0 | ISO/IEC 13818-1 systems bitstream so that some features of the Rec. ITU-T H.222.0 | ISO/IEC 13818-1 systems bitstream could be applied to the DSM-CC bitstream as well. In this case, the DSM-CC bitstream is embedded in the systems bitstream by the systems multiplexor.

The DSM-CC bitstream is encoded by the systems encoder in the following process. First, the DSM-CC bitstream is packetized into a packetized elementary stream (PES) according to the syntax described in 2.4.3.6. The PES packet is then multiplexed into either a program stream (PS) or a transport stream (TS) according to the requirement of the transmission media. The decoding procedures are the inverse of the encoding procedures and are illustrated in the block diagram of the Systems decoder depicted in Figure B.3.

In Figure B.3, the output of the Systems decoder is a video bitstream, audio bitstream and/or DSM-CC bitstream. The DSM-CC bitstream is identified by the stream\_id, value '1111 0010' as defined by the stream\_id Table 2-22. Once the DSM-CC bitstream is identified, it follows the rules as specified by T-STD or P-STD.

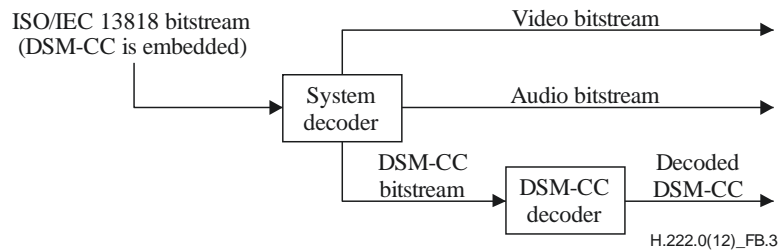

Figure B.3 – DSM-CC bitstream decoded as part of the system bitstream

## B.3 Technical elements

### B.3.1 Definitions

For the purposes of this Recommendation | International Standard, the following definitions apply:

**B.3.1.1 DSM-CC:** Digital Storage Media Command and Control Commands that are specified by Rec. ITU-T H.222.0 | ISO/IEC 13818-1 for the control of digital storage media at a local or remote site containing a Rec. ITU-T H.222.0 | ISO/IEC 13818-1 bitstream.

**B.3.1.2 DSM ACK:** The acknowledgement from the DSM-CC command receiver to the command initiator.

**B.3.1.3 MPEG bitstream:** An ISO/IEC 11172-1 Systems stream, Rec. ITU-T H.222.0 | ISO/IEC 13818-1 program stream or Rec. ITU-T H.222.0 | ISO/IEC 13818-1 transport stream.

**B.3.1.4 DSM-CC server:** A system, either local or remote, used to store and/or retrieve a Rec. ITU-T H.222.0 | ISO/IEC 13818-1 bitstream.

**B.3.1.5 point of random access:** A point in a Rec. ITU-T H.222.0 | ISO/IEC 13818-1 bitstream with the property that for at least one elementary stream within the bitstream, the next access unit, 'N', completely contained in the bitstream can be decoded without reference to previous access units, and for every elementary stream in the bitstream all access units with the same or later presentation times are completely contained subsequently in the bitstream and can be completely decoded by a system target decoder without access to information prior to the point of random access. The bitstream as stored on the DSM may have certain points of random access; the output of the DSM may include additional points of random access manufactured by the DSM's own manipulation of the stored material (e.g., storing quantization matrices so that a sequence header can be generated whenever necessary). A point of random access has an associated PTS, namely the actual or implied PTS of access unit 'N'.

**B.3.1.6 current operational PTS value:** The actual or implied PTS associated with the last point of random access preceding the last access unit provided from the DSM from the currently selected Rec. ITU-T H.222.0 | ISO/IEC 13818-1 bitstream. If no access unit has been provided from this Rec. ITU-T H.222.0 | ISO/IEC 13818-1 bitstream, the DSM is incapable of providing random access into the current bitstream, then the current operational PTS value is the first point of random access in the Rec. ITU-T H.222.0 | ISO/IEC 13818-1 bitstream.

**B.3.1.7 DSM-CC bitstream:** A sequence of bits satisfying the syntax of B.3.2.

### B.3.2 Specification of DSM-CC syntax

- Every DSM control command shall commence with a `start_code`, as specified in Table B.1.
- Every DSM control command shall have a `packet_length` to specify the number of bytes in a DSM-CC packet.
- When the DSM-CC bitstream is transmitted as a PES packet as defined in 2.4.3.6, the fields up to the `packet_length` field are identical to those specified in 2.4.3.6. In other words, if the DSM-CC packet is encapsulated in a PES packet, the PES packet start code is the only start code at the beginning of the packet.
- The actual control command or acknowledgement shall follow the last byte of the `packet_length` field.
- An acknowledgement stream shall be provided by the DSM control bitstream receiver after the requested operation is started or is completed, depending on the command received.
- At all times the DSM is responsible for providing a normative Rec. ITU-T H.222.0 | ISO/IEC 13818-1 stream. This may include manipulating the trick mode bits defined in 2.4.3.6.

Table B.1 – DSM-CC syntax

Syntax	No. of bits	Mnemonic
DSM_CC() {		
<b>packet_start_code_prefix</b>	<b>24</b>	<b>bslbf</b>
<b>stream_id</b>	<b>8</b>	<b>uimsbf</b>
<b>packet_length</b>	<b>16</b>	<b>uimsbf</b>
<b>command_id</b>	<b>8</b>	<b>uimsbf</b>
If (command_id == '01') {		
control()		
} else if (command_id == '02') {		
ack()		
}		
}		

### B.3.3 Semantics of fields in specification of DSM-CC syntax

**packet\_start\_code\_prefix** – This is a 24-bit code. Together with the stream\_id that follows it constitutes a DSM-CC packet start code that identifies the beginning of a DSM-CC packet bitstream. The packet\_start\_code\_prefix is the bit string '0000 0000 0000 0000 0000 0001' (0x000001).

**stream\_id** – This 8-bit field specifies the bitstream type and shall have a value '1111 0010' for the DSM-CC bitstream. Refer to Table 2-22.

**packet\_length** – This 16-bit field specifies the number of bytes in the DSM-CC packet immediately following the last byte of this field.

**command\_id** – This 8-bit unsigned integer identifies the bitstream is a control command or an acknowledgement stream. The values are defined in Table B.2.

Table B.2 – Command\_id assigned values

Value	Command_id
0x00	Forbidden
0x01	Control
0x02	Ack
0x03 .. 0xFF	Reserved

### B.3.4 Control layer

#### Constraints on setting flags in DSM-CC control

- At most one of the flags for select, playback and storage shall be set to '1' for each DSM control command. If none of these bits are set, then this command shall be ignored.
- At most one of pause\_mode, resume\_mode, stop\_mode, play\_flag, and jump\_flag shall be set for each retrieval command. If none of these bits are set, then this command shall be ignored.
- At most one of record\_flag and stop\_mode shall be selected for each storage command. If none of these bits are set, then this command shall be ignored.

See Table B.3.

Table B.3 – DSM-CC control

Syntax	No. of bits	Mnemonic
control() {		
<b>select_flag</b>	1	bslbf
<b>retrieval_flag</b>	1	bslbf
<b>storage_flag</b>	1	bslbf
<b>reserved</b>	12	bslbf
<b>marker_bit</b>	1	bslbf
If (select_flag == '1') {		
<b>bitstream_id</b> [31..17]	15	bslbf
<b>marker_bit</b>	1	bslbf
<b>bitstream_id</b> [16..2]	15	bslbf
<b>marker_bit</b>	1	bslbf
<b>bitstream_id</b> [1..0]	2	bslbf
<b>select_mode</b>	5	bslbf
<b>marker_bit</b>	1	bslbf
}		
if ( retrieve_flag == '1') {		
<b>jump_flag</b>	1	bslbf
<b>play_flag</b>	1	bslbf
<b>pause_mode</b>	1	bslbf
<b>resume_mode</b>	1	bslbf
<b>stop_mode</b>	1	bslbf
<b>reserved</b>	10	bslbf
<b>marker_bit</b>	1	bslbf
if (jump_flag == '1') {		
<b>reserved</b>	7	bslbf
<b>direction_indicator</b>	1	bslbf
time_code()		
}		
if (play_flag == '1'){		
<b>speed_mode</b>	1	bslbf
<b>direction_indicator</b>	1	bslbf
<b>reserved</b>	6	bslbf
time_code()		
}		
}		
if (storage_flag == '1') {		
<b>reserved</b>	6	bslbf
<b>record_flag</b>	1	bslbf
<b>stop_mode</b>	1	bslbf
if (record_flag == '1') {		
time_code()		
}		
}		
}		

**B.3.5 Semantics of fields in control layer**

**marker\_bit** – This is a 1-bit marker that is always set to '1' to avoid start code emulation.

**reserved\_bits** – This 12-bit field is reserved for future use by this Recommendation | International Standard for DSM control commands. Until otherwise specified by ITU-T | ISO/IEC it shall have the value '0000 0000 0000'.

**select\_flag** – This 1-bit flag when set to '1' specifies a bitstream selection operation. When it is set to '0' no bitstream selection operation shall occur.

**retrieval\_flag** – This 1-bit flag when set to '1' specifies that a specific retrieval (playback) action will occur. The operation starts from the current operational PTS value.

**storage\_flag** – This 1-bit flag when set to '1' specifies that a storage operation is to be executed.

**bitstream\_ID** – This 32-bit field is coded in three parts. The parts are combined to form an unsigned integer specifying which Rec. ITU-T H.222.0 | ISO/IEC 13818-1 bitstream is to be selected. It is the DSM server's responsibility to map the names of the Rec. ITU-T H.222.0 | ISO/IEC 13818-1 bitstreams stored on its DSM uniquely to a series of numbers which could be represented by the bitstream\_ID.

**select\_mode** – This 5-bit unsigned integer specifies which mode of bitstream operation is requested. Table B.4 specifies the defined modes.

**Table B.4 – Select mode assigned values**

Code	Mode
0x00	Forbidden
0x01	Storage
0x02	Retrieval
0x03 .. 0x1F	Reserved

**jump\_flag** – This 1-bit flag when set to '1' specifies a jump in the playback pointer to a new access unit. The new PTS is specified by a relative time\_code with respect to the current operational PTS value. This function is only valid when the current Rec. ITU-T H.222.0 | ISO/IEC 13818-1 bitstream is in the "stop" mode.

**play\_flag** – This 1-bit flag when set to '1' specifies to play a bitstream for a certain time period. The speed, direction, and play duration are additional parameters in the bit stream. The play starts from the current operational PTS value.

**pause\_mode** – This is a one-bit code specifying to pause the playback action and keep the playback pointer at the current operational PTS value.

**resume\_mode** – This is a one-bit code specifying to continue the playback action from the current operational PTS value. Resume only has meaning if the current bitstream is in the "pause" state, and the bitstream will be set to the forward play state at normal speed.

**stop\_mode** – This is a one-bit code specifying to stop a bitstream transmission.

**direction\_indicator** – This is a one-bit code to indicate the playback direction. If this bit is set to '1', it stands for a forward play. Otherwise it stands for a backward play.

**speed\_mode** – This is a 1-bit code to specify the speed scale. If this bit is set to '1', it specifies that the speed is normal play. If this bit is set to '0', it specifies that the speed is fast play (i.e., fast forward or fast reverse).

**record\_flag** – This is one-bit flag to specify the request of recording the bitstream from an end user to a DSM for a specified duration or until the reception of a stop command, whichever comes first.

### B.3.6 Acknowledgement layer

#### Constraints on setting flags in DSM-CC control

Only one of the acks bits specified below can be set to '1' for each DSM ack bitstream (see Table B.5).

Table B.5 – DSM-CC Acknowledgement

Syntax	No. of bits	Mnemonic
ack() {		
<b>select_ack</b>	<b>1</b>	<b>bslbf</b>
<b>retrieval_ack</b>	<b>1</b>	<b>bslbf</b>
<b>storage_ack</b>	<b>1</b>	<b>bslbf</b>
<b>error_ack</b>	<b>1</b>	<b>bslbf</b>
<b>reserved</b>	<b>10</b>	<b>bslbf</b>
<b>marker_bit</b>	<b>1</b>	<b>bslbf</b>
<b>cmd_status</b>	<b>1</b>	<b>bslbf</b>
If (cmd_status == '1' && (retrieval_ack == '1'    storage_ack == '1')) {		
time_code()		
}		
}		

**B.3.7 Semantics of fields in acknowledgement layer**

**select\_ack** – This 1-bit field when it is set to '1' indicates that the ack() command is to acknowledge a select command.

**retrieval\_ack** – This 1-bit field when set to '1' indicates that the ack() command is to acknowledge a retrieval command.

**storage\_ack** – This 1-bit field when set to '1' indicates that the ack() command is to acknowledge a storage command.

**error\_ack** – This 1-bit field when set to '1' indicates a DSM error. The defined errors are EOF (end of file on forward play or start of file on reverse play) on a stream being retrieved and Disk-Full on a stream being stored. If this bit is set to '1', cmd\_status is undefined. The current bitstream is still selected.

**cmd\_status** – This 1-bit flag set to '1' indicates that the command is accepted. When set to '0' it indicates the command is rejected. The semantics vary according to the command received as follows:

- If select\_ack is set and cmd\_status is set to '1', it specifies that the Rec. ITU-T H.222.0 | ISO/IEC 13818-1 bitstream is selected and the server is ready to provide the selected mode of operation. The current operational PTS value is set to the first point of random access of the newly selected Rec. ITU-T H.222.0 | ISO/IEC 13818-1 bitstream. If cmd\_status is set to '0', the operation has failed and no bitstream is selected.
- If retrieval\_ack is set and cmd\_status is set to '1', it specifies that the retrieval operation is initiated for all retrieval commands. The position of the current operational PTS pointer is reported by the succeeding time\_code.
- For the play\_flag command with infinite\_time\_flag != '1', a second acknowledgement will be sent. This will acknowledge that the play operation has ended by reaching the duration defined by the play\_flag command.
- If the cmd\_status is set to '0' in a retrieval acknowledgement, the operation has failed. Possible reasons for this failure include an invalid bitstream\_ID, jumping beyond the end of a file, or a function not supported such as reverse play in standard speed.
- If storage\_ack is set, it specifies that the storage operation is being started for the record\_flag command or is completed by the stop\_mode command. The PTS of the last complete access unit stored is reported by the succeeding time\_code.
- If the recording operation is ended by reaching the duration defined by the storage\_flag command, another acknowledgement shall be sent and the current operational PTS value after the recording shall be reported.
- If the cmd\_status is set to '0' in a storage acknowledgement, the operation has failed. Possible reasons for this failure include an invalid bitstream\_ID, or the inability of the DSM to store data.

**B.3.8 Time code**

**Constraints on time code**

- A forward operation of specified duration given by a time\_code terminates after the actual or implied PTS of an access unit is observed such that PTS minus the current operational PTS value at the start of the operation modulo  $2^{33}$  exceeds the duration.

- A backward operation of specified duration given by a `time_code` terminates after the actual or implied PTS of an access unit is observed such that current operational PTS value at the start of the operation minus that PTS modulo  $2^{33}$  exceeds the duration.
- For all the commands in the `control()` layer, the `time_code` is specified as a relative duration with respect to the current operational PTS value.
- For all the commands in the `ack()` layer, the `time_code` is specified by the current operational PTS value.

See Table B.6.

Table B.6 – Time code

Syntax	No. of bits	Mnemonic
<code>time_code() {</code>		
<b>reserved</b>	7	bslbf
<b>infinite_time_flag</b>	1	bslbf
if ( <code>infinite_time_flag == '0'</code> ) {		
<b>reserved</b>	4	bslbf
<b>PTS [32..30]</b>	3	bslbf
<b>marker</b>	1	bslbf
<b>PTS [29..15]</b>	15	bslbf
<b>marker_bit</b>	1	bslbf
<b>PTS [14..0]</b>	15	bslbf
<b>marker_bit</b>	1	bslbf
}		
}		

### B.3.9 Semantics of fields in time code

**infinite\_time\_flag** – This 1-bit flag when set to '1' indicates an infinite time period. This flag is set to '1' in applications where a time period for a specific operation could not be defined in advance.

**PTS [32..0]** – The presentation timestamp of the access unit of the bitstream. Depending upon the function, this can be an absolute value or a relative time delay in cycles of the 90-kHz system clock.

## Annex C

## Program-specific information

(This annex does not form an integral part of this Recommendation | International Standard.)

### C.1 Explanation of program-specific information in transport streams

Clause 2.4.4 contains the normative syntax, semantics and text concerning program-specific information. In all cases, compliance with the constraints of 2.4.4 is required. This annex provides explanatory information on how to use the PSI functions, and considers examples of how it may be used in practice.

### C.2 Introduction

This Recommendation | International Standard provides a method for describing the contents of transport stream packets for the purpose of the demultiplexing and presentation of programs. The coding specification accommodates this function through the program-specific information (PSI). This annex discusses the use of PSI.

The PSI may be thought of as belonging to six tables:

- 1) Program association table (PAT);
- 2) TS program map table (PMT);
- 3) Network information table (NIT);
- 4) Conditional access table (CAT).
- 5) Transport stream description table (TSDT); and
- 6) IPMP control information table.

The contents of the PAT, PMT, CAT and TSDT are specified in this Recommendation | International Standard. ICIT is defined in ISO/IEC 13818-11 (MPEG-2 IPMP).

The NIT is a private table, and the PID value of the transport stream packets which carry it is specified in the PAT. Both the NIT and ICIT must follow the structure defined in this Recommendation | International Standard.

### C.3 Functional mechanism

The tables listed above are conceptual in that they need never be regenerated in a specified form within a decoder. While these structures may be thought of as simple tables, they may be partitioned before they are sent in transport stream packets. The syntax supports this operation by allowing the tables to be partitioned into sections and by providing a normative mapping method into transport stream packet payloads. A method is also provided to carry private data in a similar format. This is advantageous as the same basic processing in the decoder can then be used for both the PSI data and the private data helping to keep cost down. For advice on the optimum placing of PSI in the transport stream, see Annex D.

Each section is uniquely identified by the combination of the following elements:

i) **table\_id**

The 8-bit table\_id identifies to which table the section belongs.

- Sections with table\_id 0x00 belong to the Program Association Table.
- Sections with table\_id 0x01 belong to the Conditional Access Table.
- Sections with table\_id 0x02 belong to the TS Program Map Table.
- Sections with table\_id 0x03 belong to the TS\_description\_section.
- Sections with table\_id 0x04 belong to the ISO\_IEC\_14496\_scene\_description\_section.
- Sections with table\_id 0x05 belong to the ISO\_IEC\_14496\_object\_descriptor\_section.
- Sections with table\_id 0x06 belong to the metadata\_section.
- Sections with table\_id 0x07 belong to the IPMP\_Control\_Information\_section.

Other values of the table\_id can be allocated by the user for private purposes.

It is possible to set up filters looking at the table\_id field to identify whether a new section belongs to a table of interest or not.

ii) **table\_id\_extension**

This 16-bit field exists in the long version of a section. In the Program Association Table it is used to identify the `transport_stream_id` of the stream – effectively a user-defined label which allows one transport stream to be distinguished from another within a network or across networks. In the conditional access table this field currently has no meaning and is therefore marked as "reserved" meaning that it shall be coded as 0xFFFF, but that a meaning may be defined by ITU-T | ISO/IEC in a subsequent revision of this Recommendation | International Standard. In a TS Program Map section the field contains the `program_number`, and thereby identifies the program to which the data in the section refers. The `table_id_extension` can also be used as a filter point in certain cases.

iii) **section\_number**

The `section_number` field allows the sections of a particular table to be reassembled in their original order by the decoder. There is no obligation within this Recommendation | International Standard that sections must be transmitted in numerical order, but this is recommended, unless it is desired to transmit some sections of the table more frequently than others, e.g., due to random access considerations.

iv) **version\_number**

When the characteristics of the transport stream described in the PSI change (e.g., extra programs added, different composition of elementary streams for a given program), then new PSI data has to be sent with the updated information as the most recently transmitted version of the sections marked as "current" must always be valid. Decoders need to be able to identify whether the most recently received section is identical with the section they have already processed/stored (in which case the section can be discarded), or whether it is different, and may therefore signify a configuration change. This is achieved by sending a section with the same `table_id`, `table_id_extension`, and `section_number` as the previous section containing the relevant data, but with the next value `version_number`.

v) **current\_next\_indicator**

It is important to know at what point in the bitstream the PSI is valid. Each section can therefore be numbered as valid "now" (current), or as valid in the immediate future (next). This allows the transmission of a future configuration in advance of the change, giving the decoder the opportunity to prepare for the change. There is however no obligation to transmit the next version of a section in advance, but if it is transmitted, then it shall be the next correct version of that section.

## C.4 The mapping of sections into transport stream packets

Sections are mapped directly into transport stream packets, that is to say, without a prior mapping into PES packets. Sections do not have to start at the beginning of transport stream packets, (although they may), because the start of the first section in the payload of a transport stream packet is pointed to by the `pointer_field`. The presence of the `pointer_field` is signalled by the `payload_unit_start_indicator` being set to a value of '1' in PSI packets. (In non-PSI packets, the indicator signals that a PES packet starts in the transport stream packet.) The `pointer_field` points to the start of the first section in the transport stream packet. There is never more than one `pointer_field` in a transport stream packet, as the start of any other section can be identified by counting the length of the first and any subsequent sections, since no gaps between sections within a transport stream packet are allowed by the syntax.

It is important to note that within transport stream packets of any single PID value, one section must be finished before the next one is allowed to be started, or else it is not possible to identify to which section header the data belongs. If a section finishes before the end of a transport stream packet, but it is not convenient to open another section, a stuffing mechanism is provided to fill up the space. Stuffing is performed by filling each remaining byte of the packet with the value 0xFF. Consequently the `table_id` value 0xFF is forbidden, or else this would be confused with stuffing. Once a 0xFF byte has occurred at the end of a section, then the rest of the transport stream packet must be stuffed with 0xFF bytes, allowing a decoder to discard the rest of the transport stream packet. Stuffing can also be performed using the normal `adaptation_field` mechanism.

## C.5 Repetition rates and random access

In systems where random access is a consideration, it is recommended to re-transmit PSI sections several times, even when changes do not occur in the configuration, as in the general case, a decoder needs the PSI data to identify the contents of the transport stream, to be able to start decoding. This Recommendation | International Standard does not place any requirements on the repetition or occurrence rate of PSI sections. Clearly though, repeating sections frequently helps random access applications, whilst causing an increase in the amount of bitrate used by PSI data. If program mappings are static or quasi-static, they may be stored in the decoder to allow faster access to the data than having to wait for it to be re-transmitted. The trade-off between the amount of storage required and the desired impact on channel acquisition time may be made by the decoder manufacturer.

## C.6 What is a program?

The concept of a program has a precise definition within this Recommendation | International Standard [refer to 2.1.125 program (system)]. For a transport stream the time base is defined by the PCR. This effectively creates a virtual channel within the transport stream.

Note that this is not the same definition as is commonly used in broadcasting, where a "program" is a collection of elementary streams not only with a common time base, but also with a common start and end time. A series of "broadcaster programs" (referred to in this annex as events) can be transmitted sequentially in a transport stream using the same program\_number to create a "broadcasting conventional" TV-channel (sometimes called a service).

Event descriptions could be transmitted in private\_sections().

A program is denoted by a program\_number which has significance only within a transport stream. The program\_number is a 16-bit unsigned integer and thus permits 65535 unique programs to exist within a transport stream (program\_number 0 is reserved for identification of the NIT). Where several transport streams are available to the decoder (e.g., in a cable network), in order to successfully demultiplex a program, the decoder must be notified of both the transport\_stream\_id (to find the right multiplex) and the program\_number of the service (to find the right program within the multiplex).

The transport stream mapping may be accomplished via the optional network information table. Note that the network information table may be stored in decoder non-volatile memory to reduce channel acquisition time. In this case, it needs to be transmitted only often enough to support timely decoder initialization set-up operations. The contents of the NIT are private, but shall take at least the minimum section structure.

## C.7 Allocation of program\_number

It may not be convenient in all cases to group together all the program elements which share a common clock reference as one program. It is conceivable to have a multi-service transport stream with only one set of PCRs, common to all. In general, though, a broadcaster may prefer to logically split up the transport stream into several programs, where the PCR\_PID (location of the clock reference) is always the same. This method of splitting the program elements into pseudo-independent programs can have several uses. Two examples follow:

i) *multilingual transmissions into separate markets*

One video stream may be accompanied by several audio streams in different languages. It is advisable to include an example of the ISO\_639\_language\_descriptor associated with each audio stream to enable the selection of the correct program and audio. It is reasonable to have several program definitions with different program\_numbers, where all the programs reference the same video stream and PCR\_PID, but have different audio PIDs. It is, however, also reasonable and possible to list the video stream and all the audio streams as one program, where this does not exceed the section size limit of 1024 bytes.

ii) *Very large program definitions*

There is a maximum limit on the length of a section of 1024 bytes (including section header and CRC\_32). This means that no single program definition may exceed this length. For the great majority of cases, even with each program element having several descriptors, this size is adequate. However, one may envisage cases in very high bitrate systems, which could exceed this limit. It is then in general possible to identify methods of splitting the references of the streams, so that they do not all have to be listed together. Some program elements could be referenced under more than one program, and some under only one or the other, but not both.

## C.8 Usage of PSI in a typical system

A communications system, especially in broadcast applications, may consist of many individual transport streams. Each one of the four PSI data structures may appear in each and every transport stream in a system. There must always be a complete version of the program association table listing all programs within the transport stream and a complete TS program map table, containing complete program definitions for all programs within the transport stream. If any streams are scrambled, then there must also be a conditional access table present listing the relevant Entitlement Management Messages (EMM) streams. The presence of a NIT is fully optional.

The PSI tables are mapped into transport stream packets via the section structure described above. Each section has a table\_id field in its header, allowing sections from PSI tables and private data in private\_sections to be mixed in transport stream packets of the same PID value or even in the same transport stream packet. Note, however, that within packets of the same PID, a complete section must be transmitted before the next section can be started. This is only possible for packets labelled as containing TS Program Map Table section or NIT packets however, since private sections may not be mapped into PAT or CAT packets.

It is required that all PAT sections be mapped into transport stream packets with PID = 0x0000 and all CA sections be mapped into packets with PID = 0x0001. PMT sections may be mapped into packets of user-selected PID value, listed as the PMT\_PID for each program in the Program Association Table. Likewise, the PID for the NIT-bearing transport stream packets is user-selected, but must be pointed to by the entry "program\_number = 0x00" in the PAT, if the NIT exists.

The contents of any CA parameter streams are entirely private, but EMMs and ECMs must also be sent in transport stream packets to be compliant with this Recommendation | International Standard.

Private data tables may be sent using the private\_section() syntax. Such tables could be used for example in a broadcasting environment to describe a service, an upcoming event, broadcast schedules and related information.

### C.9 The relationships of PSI structures

Figure C.1 shows an example of the relationship between the four PSI structures and the transport stream. Other examples are possible, but the figure shows the primary connections.

In the following subclauses, each PSI table is described.

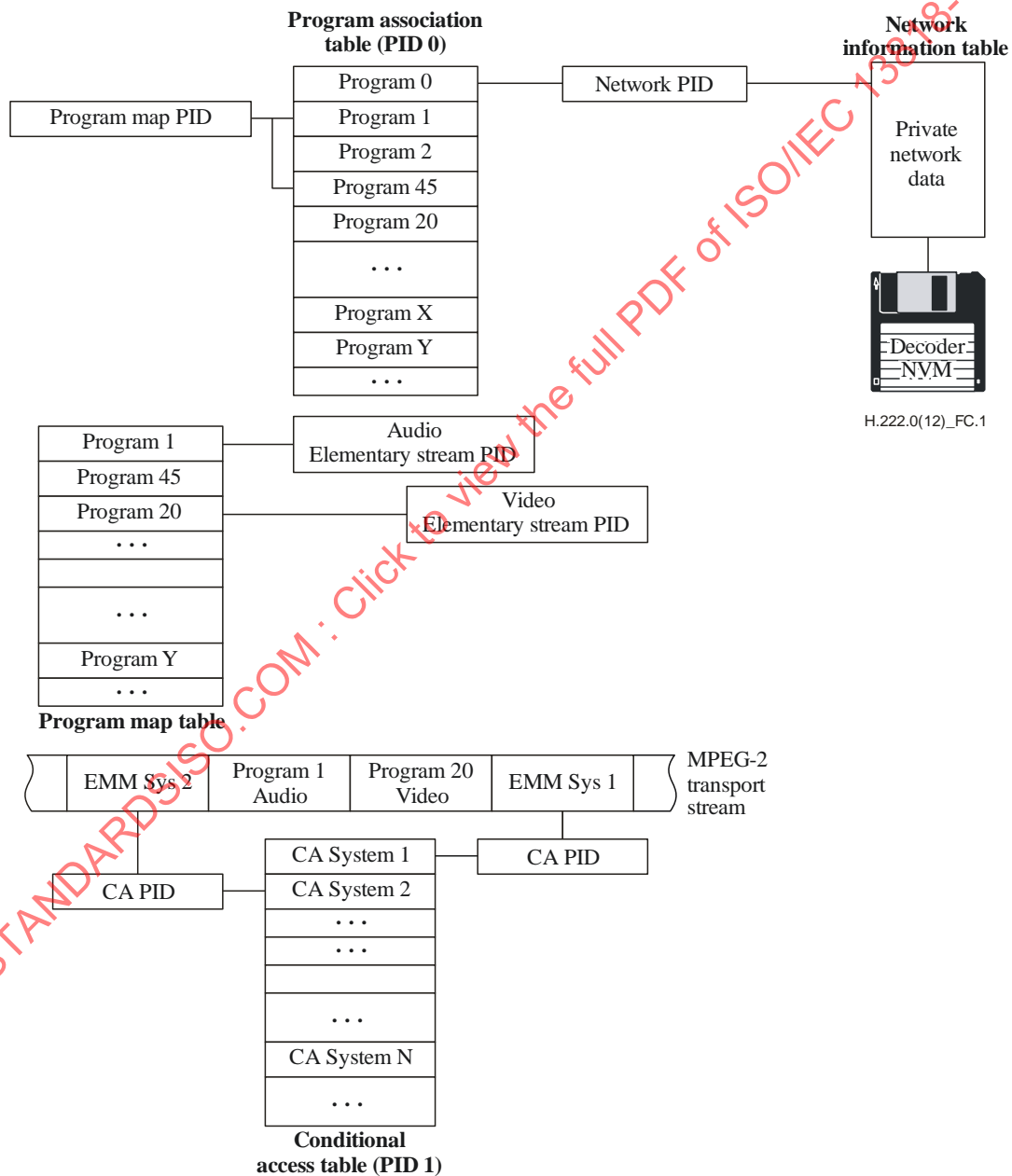

Figure C.1 – Program and network mapping relationships

### C.9.1 Program Association Table

Every transport stream must contain a complete valid Program Association Table. The Program Association Table gives the correspondence between a `program_number` and the PID of the transport stream packets that carry the definition of that program (the `PMT_PID`). The PAT may be partitioned into up to 255 sections before it is mapped into transport stream packets. Each section carries a part of the overall PAT. This partitioning may be desirable to minimize data loss in error conditions. That is, packet loss or bit errors may be localized to smaller sections of the PAT, thus allowing other sections to still be received and correctly decoded. If all PAT information is put into one section, an error causing a changed bit in the `table_id`, for example, would cause the loss of the entire PAT. However, this is still permitted as long as the section does not extend beyond the 1024-byte maximum length limit.

Program 0 (zero) is reserved and is used to specify the Network PID. This is a pointer to the transport stream packets which carry the network information table.

The program association table is always transmitted without encryption.

### C.9.2 Program map table

The program map table (MPT) provides the mapping between a program number and the program elements that comprise it. This table is present in transport stream packets having one or more privately-selected PID values. These transport stream packets may contain other private structures as defined by the `table_id` field. It is possible to have TS PMT sections referring to different programs carried in transport stream packets having a common PID value.

This Recommendation | International Standard requires a minimum of program identification: program number, PCR PID, stream types and program elements PIDs. Additional information for either programs or elementary streams may be conveyed by use of the `descriptor()` construct. Refer to C.9.6.

Private data may also be sent in transport stream packets denoted as carrying TS program map table sections. This is accomplished by the use of the `private_section()`. In a `private_section()` the application decides whether `version_number` and `current_next_indicator` represent the values of these fields for a single section or whether they are applicable to many sections as parts of a larger private table.

NOTE 1 – Transport stream packets containing the Program Map Table are transmitted unencrypted.

NOTE 2 – It is possible to transmit information on events in private descriptors carried within the `TS_program_map_section()`s.

### C.9.3 Conditional access table

The conditional access table (CAT) gives the association between one or more conditional access (CA) systems, their EMM streams and any special parameters associated with them.

NOTE – The (private) contents of the transport stream packets containing EMM and CA parameters if present will, in general, be encrypted (scrambled).

### C.9.4 Network information table

The contents of the network information table (NIT) are private and not specified by this Recommendation | International Standard. In general, it will contain mappings of user-selected services with `transport_stream_ids`, channel frequencies, satellite transponder numbers, modulation characteristics, etc.

### C.9.5 Private\_section()

`Private_sections()` can occur in two basic forms, the short version (where only the fields up to and including `section_length` are included) or the long version (where all the fields up to and including `last_section_number` are present, and after the private data bytes the `CRC_32` field is present).

`Private_section()`s can occur in PIDs which are labelled as `PMT_PIDs` or in transport stream packets with other PID values which contain exclusively `private_sections()`, including the PID allocated to the NIT. If the transport stream packets of the PID carrying the `private_section()`s are identified as a PID carrying `private_sections` (`stream_type` assignment value 0x05), then only `private_sections` may occur in transport stream packets of that PID value. The sections may be either of the short or long type.

### C.9.6 Descriptors

There are several normative descriptors defined in this Recommendation | International Standard. Many more private descriptors may also be defined. All descriptors have a common format: {tag, length, data}. Any privately defined descriptors must adhere to this format. The data portion of these private descriptors are privately defined.

One descriptor (the `CA_descriptor()`), is used to indicate the location (PID value of transport packets) of ECM data associated with program elements when it is found in a TS PMT section. When found in a CA section it refers to EMMs.

In order to extend the number of private\_descriptors available, the following mechanism could be used: A private descriptor\_tag could be privately defined to be constructed as a composite descriptor. This entails privately defining a further sub\_descriptor as the first field of the private data bytes of the private descriptor. The described structure is as indicated in Tables C.1 and C.2.

Table C.1 – Composite\_descriptor

Syntax	No. of bits	Mnemonic
<pre>Composite_descriptor(){     descriptor_tag(privately defined)     descriptor_length     for (i = 0; i &lt; N; i++){         sub_descriptor()     } }</pre>	<p>8</p> <p>8</p>	<p>uimsbf</p> <p>uimsbf</p>

Table C.2 – Sub-descriptor

Syntax	No. of bits	Mnemonic
<pre>sub_descriptor() {     sub_descriptor_tag     sub_descriptor_length     for (i = 0; i &lt; N; i++) {         private_data_byte     } }</pre>	<p>8</p> <p>8</p> <p>8</p>	<p>uimsbf</p> <p>uimsbf</p> <p>uimsbf</p>

### C.10 Bandwidth utilization and signal acquisition time

Any implementation of a Rec. ITU-T H.222.0 | ISO/IEC 13818-1 bitstream must make reasonable bandwidth demands for PSI information and, in applications where random access is a consideration, should promote fast signal acquisition. This subclause analyses this issue and gives some broadcast application examples.

The packet-based nature of the transport stream allows for the interspersing of PSI information with fine granularity in the multiplexed data. This provides significant flexibility in the construction and transmission of PSI.

Signal acquisition time in a real decoder is dependent on many factors, including: FDM tuning slew time, demultiplexing time, sequence headers, I-frame occurrence rate and scrambling key retrieval and processing.

This subclause examines both the bitrate and signal acquisition time impacts of the PSI syntax in 2.4.4.4 and 2.4.4.9. It is assumed that the conditional access table does not need to be received dynamically at every program change. This assumption is also made of the private EMM streams. This is because these streams do not contain the quickly-varying ECM components used for program element scrambling (encryption).

Also, in the discussion below, the time to acquire and process ECMs has been neglected.

Tables C.3 and C.4 provide bandwidth usage values for a range of transport stream conditions. One axis of the table is the number of programs contained in a single transport stream. The other axis is the frequency with which the PSI information is transmitted in the transport stream.

**Table C.3 – Program association table bandwidth usage (bit/s)  
Number of programs per transport stream**

Frequency of PA table Information (s <sup>-1</sup> )		1	5	10	32	128
	1	1504	1504	1504	1504	4512
	10	15040	15040	15040	15040	45120
	25	37600	37600	37600	37600	112800
	50	75200	75200	75200	75200	225600
	100	150400	150400	150400	150400	451200

NOTE – Since 46 **program\_association\_sections** fit into one transport packet, the numbers in the table do not change until the last column.

**Table C.4 – Program map table bandwidth usage (bit/s)  
Number of programs per transport stream**

Frequency of PM table Information (s <sup>-1</sup> )		1	5	10	32	128
	1	1504	1504	3008	7520	28576
	10	15040	15040	30080	75200	285760
	25	37600	37600	75200	188000	714400
	50	75200	75200	150400	376000	1428800
	100	150400	150400	300800	601600	2857600

This frequency will be a key determinant of the component of signal acquisition time due to PSI structures.

Both bandwidth usage tables assume that only the minimum program mapping information is provided. This means that the PID values and stream types are provided with no additional descriptors. All programs in the example are composed of two elementary streams. Program associations are 2 bytes long, while the minimal program map is 26 bytes long. There is additional overhead associated with version numbers, section lengths, etc. This will be on the order of 1-3% of the total PSI bitrate usage in sections of moderate to maximum length (a few hundred bytes to 1024 bytes) and will thus be ignored here.

The above assumptions allow forty-six (46) program associations to map into one Program Association Table transport stream packet (if no adaptation field is present). Similarly, seven (7) TS\_program\_map\_sections fit into a single transport stream packet. It may be noted that to facilitate easy "drop/add" it is possible to transmit only one (1) TS\_program\_map\_section per PMT\_PID. This may cause an undesirable increase in PSI bitrate usage, however.

Using a frequency of 25 Hz for the two PSI Tables, yields a worst-case contribution to the signal acquisition time of approximately 80 ms. This would only occur when the required PAT data was "just missed" and then, once the PAT was acquired and decoded, the required PMT data was also "just missed". This doubling of the worst case acquisition time is one disadvantage of the extra level of indirection introduced by the PAT structure. This effect could be reduced by coordinated transmission of related PAT and PMT packets. Presumably, the advantage that this approach offers for "drop/add" re-multiplexing operations is compensatory.

With the 25-Hz PSI frequency, the following examples may be constructed (all examples leave ample allowance for various datalink, FEC, CA and routing overheads):

#### 6-MHz CATV channel

- five 5.2-Mbit/s programs: 26.5 Mbit/s (includes transport overhead)
  - total PSI bandwidth: 5.2 kbit/s
  - CA bandwidth: 500 kbit/s
- total Rec. ITU-T H.222.0 | ISO/IEC 13818-1 transport bandwidth: 27.1 Mbit/s*
- PSI Overhead: 0.28%

#### OC-3 fibre channel (155 Mbit/s)

- 32 3.9-Mbit/s programs: 127.5 Mbit/s (includes transport overhead)
  - total PSI bandwidth: 225.6 kbit/s
  - CA bandwidth: 500 kbit/s
- total Rec. ITU-T H.222.0 | ISO/IEC 13818-1 transport bandwidth: 128.2 Mbit/s*
- PSI Overhead: 0.18%

**C-band satellite transponder**

- 128 256-kbit/s audio programs: 33.5 Mbit/s (includes transport overhead)
  - total PSI bandwidth: 826.4 kbit/s
  - CA bandwidth: 500 kbit/s
- total Rec. ITU-T H.222.0 | ISO/IEC 13818-1 transport bandwidth: 34.7 Mbit/s*
- PSI overhead: 2.4% (actually would be lower if only one PID used per program)

As expected, the percent overhead increases for lower-rate services since many more services are possible per transport stream. However, the overhead is not excessive in all cases. Higher transmission rates (than 25 Hz) for the PSI data may be used to decrease the impact on channel acquisition time with only modest bitrate demand increases.

STANDARDSISO.COM : Click to view the full PDF of ISO/IEC 13818-1:2023

## Annex D

## Systems timing model and application implications of this Recommendation | International Standard

(This annex does not form an integral part of this Recommendation | International Standard.)

### D.1 Introduction

The Rec. ITU-T H.222.0 | ISO/IEC 13818-1 Systems specification includes a specific timing model for the sampling, encoding, encoder buffering, transmission, reception, decoder buffering, decoding, and presentation of digital audio and video in combination. This model is embodied directly in the specification of the syntax and semantic requirements of compliant Rec. ITU-T H.222.0 | ISO/IEC 13818-1 data streams. Given that a decoding system receives a compliant bit stream that is delivered correctly in accordance with the timing model it is straightforward to implement the decoder such that it produces as output high quality audio and video which are properly synchronized. There is no normative requirement, however, that decoders be implemented in such a way as to provide such high quality presentation output. In applications where the data are not delivered to the decoder with correct timing, it may be possible to produce the desired presentation output; however, such capabilities are not in general guaranteed. This informative annex describes the Rec. ITU-T H.222.0 | ISO/IEC 13818-1 Systems timing model in detail, and gives some suggestions for implementing decoder systems to suit some typical applications.

#### D.1.1 Timing model

Rec. ITU-T H.222.0 | ISO/IEC 13818-1 Systems embodies a timing model in which all digitized pictures and audio samples that enter the encoder are presented exactly once each, after a constant end to end delay, at the output of the decoder. As such, the sample rates, i.e., the video frame rate and the audio sample rate, are precisely the same at the decoder as they are at the encoder. This timing model is diagrammed in Figure D.1:

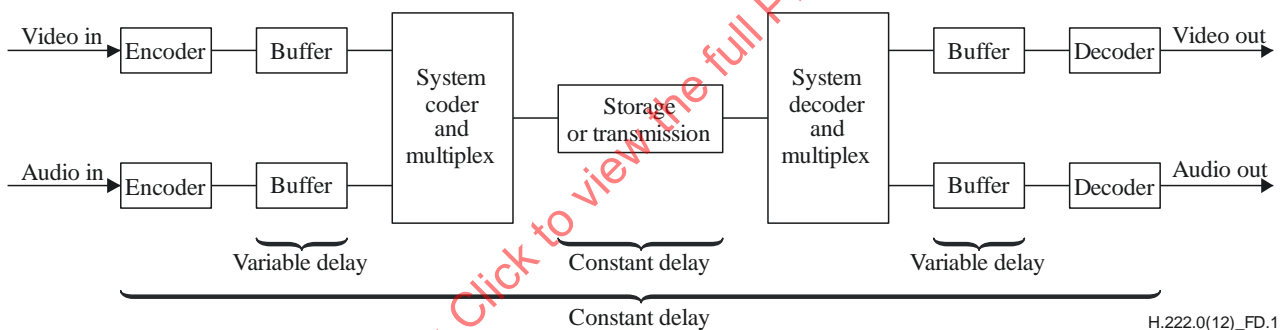

Figure D.1 – Constant delay model

As indicated in Figure D.1, the delay from the input to the encoder to the output or presentation from the decoder is constant in this model<sup>1)</sup> while the delay through each of the encoder and decoder buffers is variable. Not only is the delay through each of these buffers variable within the path of one elementary stream, but the individual buffer delays in the video and audio paths differ as well. Therefore, the relative location of coded bits representing audio or video in the combined stream does not indicate synchronization information. The relative location of coded audio and video is constrained only by the System Target Decoder (STD) model such that the decoder buffers must behave properly; therefore coded audio and video that represent sound and pictures that are to be presented simultaneously may be separated in time within the coded bit stream by as much as one second, which is the maximum decoder buffer delay that is allowed in the STD model.

The audio and video sample rates at the encoder are significantly different from one another, and may or may not have an exact and fixed relationship to one another, depending on whether the combined stream is a program stream or a transport stream, and on whether the System\_audio\_locked and System\_video\_locked flags are set in the program stream. The duration of a block of audio samples (an audio presentation unit) is generally not the same as the duration of a video picture.

<sup>1)</sup> Constant delay as indicated for the entire system is required for correct synchronization, however some deviations are possible. Network delay is discussed as being constant. Slight deviations may be tolerated, and network adaptation may allow greater variations of network delay. Both of these are discussed later.

There is a single, common system clock in the encoder, and this clock is used to create timestamps that indicate the correct presentation and decoding timing of audio and video, as well as to create timestamps that indicate the instantaneous values of the system clock itself at sampled intervals. The timestamps that indicate the presentation time of audio and video are called Presentation Time Stamps (PTS). Those that indicate the decoding time are called Decoding Timestamps (DTS), and those that indicate the value of the system clock are called the System Clock Reference (SCR) in program streams and the Program Clock Reference (PCR) in transport streams. It is the presence of this common system clock in the encoder, the timestamps that are created from it, and the recreation of the clock in the decoder and the correct use of the timestamps that provide the facility to synchronize properly the operation of the decoder.

Encoder implementations may not follow this model exactly; however, the data stream which results from the actual encoder, storage system, network, and one or more multiplexor must follow the model precisely. (Delivery of the data may deviate somewhat, depending on the application). Therefore in this annex, the term "encoder system clock" is used to mean either the actual common system clock as described in this model or the equivalent function, however it may be implemented.

Since the end-to-end delay through the entire system is constant, the audio and video presentations are precisely synchronized. The construction of System bit streams is constrained such that when they are decoded by a decoder that follows this model with the appropriately sized decoder buffers, those buffers are guaranteed never to overflow nor underflow, with specific exceptions allowing intentional underflow.

In order for the decoder system to incur the precise amount of delay that causes the entire end-to-end delay to be constant, it is necessary for the decoder to have a system clock whose frequency of operation and absolute instantaneous value match those of the encoder. The information necessary to convey the encoder's system clock is encoded in the SCR or PCR; this function is explained below.

Decoders which are implemented in accordance with this timing model such that they present audio samples and video pictures exactly once (with specific intentionally coded exceptions), at a constant rate, and such that decoder buffers behave as in the model, are referred to in this annex as precisely timed decoders, or those that produce precisely timed output. Decoder implementations are not required by this International Standard to present audio and video in accordance with this model; it is possible to construct decoders that do not have constant delay, or equivalently do not present each picture or audio sample exactly once. In such implementations, however, the synchronization between presented audio and video may not be precise, and the behaviour of the decoder buffers may not follow the reference decoder model. It is important to avoid overflow at the decoder buffers, as overflow causes a loss of data that may have significant effects on the resulting decoding process. This annex covers primarily the operation of such precisely timed decoders and some of the options that are available in implementing these decoders.

### D.1.2 Audio and video presentation synchronization

Within the coding of this Recommendation | International Standard Systems data are timestamps concerning the presentation and decoding of video pictures and blocks of audio samples. The pictures and blocks are called "Presentation Units", abbreviated PU. The sets of coded bits which represent the PUs and which are included within the Rec. ITU-T H.222.0 | ISO/IEC 13818-1 bit stream are called "Access Units", abbreviated AU. An audio access unit is abbreviated AAU, and a video access unit is abbreviated VAU. In ISO/IEC 13818-3 audio the term "audio frame" has the same meaning as AAU or APU (audio presentation unit) depending on the context. A video presentation unit (VPU) is a picture, and a VAU is a coded picture.

Some, but not necessarily all, AAUs and VAUs have associated with them PTSs. A PTS indicates the time that the PU which results from decoding the AU which is associated with the PTS should be presented to the user. The audio PTSs and video PTSs are both samples from a common time clock, which is referred to as the System Time Clock or STC. With the correct values of audio and video PTSs included in the data stream, and with the presentation of the audio and video PUs occurring at the time indicated by the appropriate PTSs in terms of the common STC, precise synchronization of the presented audio and video is achieved at the decoding system. While the STC is not part of the normative content of this Recommendation | International Standard, and the equivalent information is conveyed in this Recommendation | International Standard via such terms as the `system_clock_frequency`, the STC is an important and convenient element for explaining the timing model, and it is generally practical to implement encoders and decoders which include an STC in some form.

PTSs are required for the conveyance of accurate relative timing between audio and video, since the audio and video PUs generally have significantly different and essentially unrelated duration. For example, audio PUs of 1152 samples each at a sample rate of 44 100 samples per second have a duration of approximately 26.12 ms, and video PUs at a frame rate of 29.97 Hz have a duration of approximately 33.76 ms. In general the temporal boundaries of APUs and VPUs rarely, if ever, coincide. Separate PTSs for audio and video provide the information that indicates the precise temporal relation of audio and video PUs without requiring any specific relationship between the duration and interval of audio and video PUs.

The values of the PTS fields are defined in terms of the System Target Decoder or STD, which is a fundamental normative constraint on all System bit streams. The STD is a mathematical model of an idealized decoder which specifies precisely the movement of all bits into and out of the decoder's buffers, and the basic semantic constraint imposed on the bit stream is that the buffers within the STD must never overflow nor underflow, with specific exceptions provided for underflow in special cases. In the STD model the virtual decoder is always exactly synchronized with the data source, and audio and video decoding and presentation are exactly synchronized. While exact and consistent, the STD is somewhat simplified with respect to physical implementations of decoders in order to clarify its specification and to facilitate its broad application to a variety of decoder implementations. In particular, in the STD model each of the operations performed on the bit stream in the decoder is performed instantaneously, with the obvious exception of the time that bits spend in the decoder buffers. In a real decoder system the individual audio and video decoders do not perform instantaneously, and their delays must be taken into account in the design of the implementation. For example, if video pictures are decoded in exactly one picture presentation interval  $1/P$ , where  $P$  is the frame rate, and compressed video data are arriving at the decoder at bit rate  $R$ , the completion of removing bits associated with each picture is delayed from the time indicated in the PTS and DTS fields by  $1/P$ , and the video decoder buffer must be larger than that specified in the STD model by  $R/P$ . The video presentation is likewise delayed with respect to the STD, and the PTS should be handled accordingly. Since the video is delayed, the audio decoding and presentation should be delayed by a similar amount in order to provide correct synchronization. Delaying decoding and presentation of audio and video in a decoder may be implemented for example by adding a constant to the PTS values when they are used within the decoder.

Another difference between the STD and precise practical decoder implementation is that in the STD model the explicit assumption is made that the final audio and video output is presented to the user instantaneously and without further delay. This may not be the case in practice, particularly with cathode-ray tube displays, and this additional delay should also be taken into account in the design. Encoders are required to encode audio and video such that the correct synchronization is achieved when the data is decoded with the STD. Delays in the input and sampling of audio and video, such as video camera optical charge integration, must be taken into account in the encoder.

In the STD model proper synchronization is assumed and the timestamps and buffer behaviour are tested against this assumption as a condition of bit stream validity. Of course, in a physical decoder precise synchronization is not automatically the case, particularly upon start-up and in the presence of timing jitter. Precise decoder timing is a goal to be targeted by decoder designs. Inaccuracy in decoder timing affects the behaviour of the decoder buffers. These topics are covered in more detail in later subclauses of this annex.

The STD includes Decoding Time Stamps (DTS) as well as PTS fields. The DTS refers to the time that an AU is to be extracted from the decoder buffer and decoded in the STD model. Since the audio and video elementary stream decoders are instantaneous in the STD, the decoding time and presentation time are identical in most cases; the only exception occurs with video pictures which have undergone re-ordering within the coded bit stream, i.e., I- and P-pictures in the case of non-low-delay video sequences. In cases where re-ordering exists, a temporary delay buffer in the video decoder is used to store the appropriate decoded I- or P-picture until it should be presented. In all cases where the decoding and presentation times are identical in the STD, i.e., all AAUs, B-picture VAUs, and I- and P-picture VAUs within low-delay video sequences, the DTS is not coded, as it would have the same value as the PTS. Where the values differ, both are coded if either is coded. For all AUs where only the PTS is coded, this field may be interpreted as being both the PTS and the DTS.

Since PTS and DTS values are not required for every AAU and VAU, the decoder may choose to interpolate values which are not coded. PTS values are required with intervals not exceeding 700 ms in each elementary audio and video stream. These time intervals are measured in presentation time, that is, in the same context as the values of the fields, not in terms of the times that the fields are transmitted and received. In cases of data streams where the system, video and audio clocks are locked, as defined in the normative part of this Recommendation | International Standard, each AU following one for which a DTS or PTS is explicitly coded has an effective decoding time of the sum of that for the previous AU plus a fixed and specified difference in value of the STC. For example, in video coded at 29.97 Hz each picture has a difference in time of 3003 cycles of the 90-kHz portion of the STC from the previous picture when the video and system clocks are locked. The same time relationship exists for decoding successive AUs, although re-ordering delay in the decoder affects the relationship between decoder AUs and presented PUs. When the data stream is coded such that the video or audio clock is not locked to the system clock the time difference between decoding successive AUs may be estimated using the same values as indicated above; however, these time differences are not exact due to the fact that relationships between the frame rate, audio sample rate, and system clock frequency were not exact at the encoder.

Note that the PTS and DTS fields do not, by themselves, indicate the correct fullness of the decoder buffers at start up nor at any other time, and equivalently, they do not indicate the amount of time delay that should elapse upon receiving the initial bits of a data stream before decoding should start. This information is retrieved by combining the functions of the PTS and DTS fields and correct clock recovery, which is covered below. In the STD model, and therefore in decoders which are modelled after it, the decoder buffer behaviour is determined completely by the SCR (or PCR) values, the times that they are received, and the PTS and DTS values, assuming that data is delivered in accordance with the timing model. This information specifies the time that coded data spends in the decoder buffers. The amount of data that is in the coded data buffers is not explicitly specified, and this information is not necessary, since the timing is fully specified. Note also