**Information technology — High
efficiency coding and media delivery
in heterogeneous environments —**

**Part 2:
High efficiency video coding**

*Technologies de l'information — Codage à haute efficacité et livraison
des médias dans des environnements hétérogènes —*

Partie 2: Codage vidéo à haute efficacité

STANDARDSISO.COM : Click to view the full PDF of ISO/IEC 23008-2:2017



STANDARDSISO.COM : Click to view the full PDF of ISO/IEC 23008-2:2017



COPYRIGHT PROTECTED DOCUMENT

© ISO/IEC 2017, Published in Switzerland

All rights reserved. Unless otherwise specified, no part of this publication may be reproduced or utilized otherwise in any form or by any means, electronic or mechanical, including photocopying, or posting on the internet or an intranet, without prior written permission. Permission can be requested from either ISO at the address below or ISO's member body in the country of the requester.

ISO copyright office
Ch. de Blandonnet 8 • CP 401
CH-1214 Vernier, Geneva, Switzerland
Tel. +41 22 749 01 11
Fax +41 22 749 09 47
copyright@iso.org
www.iso.org

Contents

Foreword	xi
Introduction.....	xii
1 Scope.....	1
2 Normative references	1
3 Terms and definitions.....	1
4 Abbreviated terms	19
5 Conventions	20
5.1 General	20
5.2 Arithmetic operators.....	21
5.3 Logical operators	21
5.4 Relational operators	21
5.5 Bit-wise operators.....	21
5.6 Assignment operators.....	22
5.7 Range notation.....	22
5.8 Mathematical functions.....	22
5.9 Order of operation precedence.....	23
5.10 Variables, syntax elements, and tables	24
5.11 Text description of logical operations.....	25
5.12 Processes.....	26
6 Bitstream and picture formats, partitionings, scanning processes, and neighbouring relationships	26
6.1 Bitstream formats.....	26
6.2 Source, decoded, and output picture formats	27
6.3 Partitioning of pictures, slices, slice segments, tiles, coding tree units, and coding tree blocks	29
6.3.1 Partitioning of pictures into slices, slice segments, and tiles.....	29
6.3.2 Block and quadtree structures	31
6.3.3 Spatial or component-wise partitionings.....	31

ISO/IEC 23008-2:2017(E)

6.4	Availability processes	32
6.4.1	Derivation process for z-scan order block availability.....	32
6.4.2	Derivation process for prediction block availability.....	33
6.5	Scanning processes	34
6.5.1	Coding tree block raster and tile scanning conversion process	34
6.5.2	Z-scan order array initialization process	36
6.5.3	Up-right diagonal scan order array initialization process.....	36
6.5.4	Horizontal scan order array initialization process	37
6.5.5	Vertical scan order array initialization process	37
6.5.6	Traverse scan order array initialization process.....	37
7	Syntax and semantics.....	38
7.1	Method of specifying syntax in tabular form.....	38
7.2	Specification of syntax functions and descriptors.....	39
7.3	Syntax in tabular form	41
7.3.1	NAL unit syntax.....	41
7.3.2	Raw byte sequence payloads, trailing bits, and byte alignment syntax	42
7.3.3	Profile, tier and level syntax	51
7.3.4	Scaling list data syntax.....	53
7.3.5	Supplemental enhancement information message syntax	54
7.3.6	Slice segment header syntax	54
7.3.7	Short-term reference picture set syntax	59
7.3.8	Slice segment data syntax.....	60
7.4	Semantics	75
7.4.1	General.....	75
7.4.2	NAL unit semantics.....	75
7.4.3	Raw byte sequence payloads, trailing bits, and byte alignment semantics	85
7.4.4	Profile, tier, and level semantics	106
7.4.5	Scaling list data semantics.....	109
7.4.6	Supplemental enhancement information message semantics	111

7.4.7	Slice segment header semantics	112
7.4.8	Short-term reference picture set semantics	120
7.4.9	Slice segment data semantics.....	123
8	Decoding process.....	138
8.1	General decoding process.....	138
8.1.1	General.....	138
8.1.2	CVSG decoding process.....	139
8.1.3	Decoding process for a coded picture with nuh_layer_id equal to 0.....	139
8.2	NAL unit decoding process	141
8.3	Slice decoding process	141
8.3.1	Decoding process for picture order count.....	141
8.3.2	Decoding process for reference picture set	142
8.3.3	Decoding process for generating unavailable reference pictures	148
8.3.4	Decoding process for reference picture lists construction.....	149
8.3.5	Decoding process for collocated picture and no backward prediction flag.....	150
8.4	Decoding process for coding units coded in intra prediction mode.....	150
8.4.1	General decoding process for coding units coded in intra prediction mode.....	150
8.4.2	Derivation process for luma intra prediction mode	155
8.4.3	Derivation process for chroma intra prediction mode.....	157
8.4.4	Decoding process for intra blocks.....	158
8.5	Decoding process for coding units coded in inter prediction mode.....	170
8.5.1	General decoding process for coding units coded in inter prediction mode.....	170
8.5.2	Inter prediction process.....	171
8.5.3	Decoding process for prediction units in inter prediction mode.....	174
8.5.4	Decoding process for the residual signal of coding units coded in inter prediction mode	206
8.6	Scaling, transformation and array construction process prior to deblocking filter process....	210
8.6.1	Derivation process for quantization parameters.....	210
8.6.2	Scaling and transformation process.....	212

ISO/IEC 23008-2:2017(E)

8.6.3	Scaling process for transform coefficients.....	214
8.6.4	Transformation process for scaled transform coefficients.....	215
8.6.5	Residual modification process for blocks using a transform bypass.....	218
8.6.6	Residual modification process for transform blocks using cross-component prediction.....	218
8.6.7	Picture construction process prior to in-loop filter process.....	219
8.6.8	Residual modification process for blocks using adaptive colour transform.....	219
8.7	In-loop filter process	222
8.7.1	General.....	222
8.7.2	Deblocking filter process	222
8.7.3	Sample adaptive offset process.....	239
9	Parsing process	242
9.1	General	242
9.2	Parsing process for 0-th order Exp-Golomb codes.....	242
9.2.1	General.....	242
9.2.2	Mapping process for signed Exp-Golomb codes.....	244
9.3	CABAC parsing process for slice segment data	244
9.3.1	General.....	244
9.3.2	Initialization process	247
9.3.3	Binarization process	260
9.3.4	Decoding process flow	269
9.3.5	Arithmetic encoding process (informative).....	285

10 Sub-bitstream extraction process.....	291
Annex A (normative) Profiles, tiers and levels	293
A.1 Overview of profiles, tiers and levels.....	293
A.2 Requirements on video decoder capability.....	293
A.3 Profiles.....	293
A.4 Tiers and levels.....	308
Annex B (normative) Byte stream format	318
B.1 General.....	318
B.2 Byte stream NAL unit syntax and semantics.....	318
B.3 Byte stream NAL unit decoding process.....	319
B.4 Decoder byte-alignment recovery (informative).....	320
Annex C (normative) Hypothetical reference decoder.....	321
C.1 General.....	321
C.2 Operation of coded picture buffer (CPB).....	327
C.3 Operation of the decoded picture buffer (DPB).....	333
C.4 Bitstream conformance.....	335
C.5 Decoder conformance.....	337
Annex D (normative) Supplemental enhancement information.....	341
D.1 General.....	341
D.2 SEI payload syntax.....	341
D.3 SEI payload semantics.....	359
Annex E (normative) Video usability information.....	443
E.1 General.....	443
E.2 VUI syntax.....	443
E.3 VUI semantics.....	446
Annex F (normative) Common specifications for multi-layer extensions.....	470
F.1 General.....	470
F.2 References	470
F.3 Definitions	470

ISO/IEC 23008-2:2017(E)

F.4	Abbreviated terms	473
F.5	Conventions	473
F.6	Bitstream and picture formats, partitionings, scanning processes, and neighbouring relationships	474
F.7	Syntax and semantics.....	474
F.8	Decoding process.....	542
F.9	Parsing process	559
F.10	Specification of bitstream subsets	559
F.11	Profiles, tiers, and levels	561
F.12	Byte stream format	564
F.13	Hypothetical reference decoder	564
F.14	Supplemental enhancement information	589
F.15	Video usability information.....	617
Annex G (normative)	Multiview high efficiency video coding	620
G.1	General.....	620
G.2	References	620
G.3	Terms and definitions.....	620
G.4	Abbreviations.....	620
G.5	Conventions	620
G.6	Bitstream and picture formats, partitionings, scanning processes, and neighbouring relationships	620
G.7	Syntax and semantics.....	620
G.8	Decoding processes	620
G.9	Parsing process	622
G.10	Specification of bitstream subsets	622
G.11	Profiles, tiers, and levels	622
G.12	Byte stream format	628
G.13	Hypothetical reference decoder	628
G.14	Supplemental enhancement information	628
G.15	Video usability information.....	643

Annex H (normative) Scalable high efficiency video coding.....	644
H.1 General.....	644
H.2 References.....	644
H.3 Definitions.....	644
H.4 Abbreviations.....	644
H.5 Conventions.....	644
H.6 Bitstream and picture formats, partitionings, scanning processes, and neighbouring relationships	644
H.7 Syntax and semantics.....	644
H.8 Decoding processes.....	644
H.9 Parsing process.....	662
H.10 Specification of bitstream subsets.....	662
H.11 Profiles, tiers, and levels.....	663
H.12 Byte stream format.....	672
H.13 Hypothetical reference decoder.....	672
H.14 Supplemental enhancement information.....	672
H.15 Video usability information.....	672
Annex I (normative) 3D high efficiency video coding.....	673
I.1 General.....	673
I.2 References.....	673
I.3 Definitions.....	673
I.4 Abbreviations.....	674
I.5 Conventions.....	674
I.6 Bitstream and picture formats, partitionings, scanning processes, and neighbouring relationships	674
I.7 Syntax and semantics.....	677
I.8 Decoding process.....	711
I.9 Parsing process.....	774
I.10 Specification of bitstream subsets.....	781
I.11 Profiles, tiers, and levels.....	781

ISO/IEC 23008-2:2017(E)

I.12 Byte stream format.....783

I.13 Hypothetical reference decoder.....783

I.14 Supplemental enhancement information.....783

Bibliography.....795

STANDARDSISO.COM : Click to view the full PDF of ISO/IEC 23008-2:2017

Foreword

ISO (the International Organization for Standardization) and IEC (the International Electrotechnical Commission) form the specialized system for worldwide standardization. National bodies that are members of ISO or IEC participate in the development of International Standards through technical committees established by the respective organization to deal with particular fields of technical activity. ISO and IEC technical committees collaborate in fields of mutual interest. Other international organizations, governmental and non-governmental, in liaison with ISO and IEC, also take part in the work. In the field of information technology, ISO and IEC have established a joint technical committee, ISO/IEC JTC 1.

The procedures used to develop this document and those intended for its further maintenance are described in the ISO/IEC Directives, Part 1. In particular the different approval criteria needed for the different types of document should be noted. This document was drafted in accordance with the editorial rules of the ISO/IEC Directives, Part 2 (see www.iso.org/directives).

Attention is drawn to the possibility that some of the elements of this document may be the subject of patent rights. ISO and IEC shall not be held responsible for identifying any or all such patent rights. Details of any patent rights identified during the development of the document will be in the Introduction and/or on the ISO list of patent declarations received (see www.iso.org/patents).

Any trade name used in this document is information given for the convenience of users and does not constitute an endorsement.

For an explanation on the voluntary nature of standards, the meaning of ISO specific terms and expressions related to conformity assessment, as well as information about ISO's adherence to the World Trade Organization (WTO) principles in the Technical Barriers to Trade (TBT) see the following URL: www.iso.org/iso/foreword.html.

This document was prepared by ISO/IEC JTC 1, *Information technology*, Subcommittee SC 29, *Coding of audio, picture, multimedia and hypermedia information*, in collaboration with ITU-T. The identical text is published as ITU-T H.265.

This third edition cancels and replaces the second edition (ISO/IEC 23008-2:2015), which has been technically revised. It also incorporates the Amendment ISO/IEC 23008-2:2015/Amd 1:2015.

A list of all parts in the ISO/IEC 23008 series can be found on the ISO website.

Introduction

As the costs for both processing power and memory have reduced, network support for coded video data has diversified, and advances in video coding technology have progressed, the need has arisen for an industry standard for compressed video representation with substantially increased coding efficiency and enhanced robustness to network environments. Toward these ends the ITU-T Video Coding Experts Group (VCEG) and the ISO/IEC Moving Picture Experts Group (MPEG) formed a Joint Collaborative Team on Video Coding (JCT-VC) in 2010 and a Joint Collaborative Team on 3D Video Coding Extension Development (JCT-3V) in 2012 for development of a new Recommendation | International Standard. This document was developed in the JCT-VC and the JCT-3V.

Purpose

This document was developed in response to the growing need for higher compression of moving pictures for various applications such as videoconferencing, digital storage media, television broadcasting, internet streaming, and communications. It is also designed to enable the use of the coded video representation in a flexible manner for a wide variety of network environments as well as to enable the use of multi-core parallel encoding and decoding devices. The use of this document allows motion video to be manipulated as a form of computer data and to be stored on various storage media, transmitted and received over existing and future networks and distributed on existing and future broadcasting channels. Supports for higher bit depths and enhanced chroma formats, including the use of full-resolution chroma are provided. Support for scalability enables video transmission on networks with varying transmission conditions and other scenarios involving multiple bit rate services. Support for multiview enables representation of video content with multiple camera views and optional auxiliary information. Support for 3D enables joint representation of video content and depth information with multiple camera views.

Applications

This document is designed to cover a broad range of applications for video content including but not limited to the following:

- broadcast (cable TV on optical networks / copper, satellite, terrestrial, etc.);
- camcorders;
- content production and distribution;
- digital cinema;
- home cinema;
- internet streaming, download and play;
- medical imaging;
- mobile streaming, broadcast and communications;
- real-time conversational services (videoconferencing, videophone, telepresence, etc.);
- remote video surveillance;
- storage media (optical disks, digital video tape recorder, etc.);
- wireless display.

Publication and versions of this document

This document has been jointly developed by ITU-T Video Coding Experts Group (VCEG) and the ISO/IEC Moving Picture Experts Group (MPEG). It is published as technically-aligned twin text in both ITU-T and ISO/IEC. As the basis text has been drafted to become both an ITU-T Recommendation and an

ISO/IEC International Standard, the term “Specification” (with capitalization to indicate that it refers to the whole of the text) is used herein when the text refers to itself.

This is the fourth version of this document and the third edition published by ISO/IEC.

Rec. ITU-T H.265 | ISO/IEC 23008-2 version 1 refers to the first approved version of this document. The first edition published by ISO/IEC as ISO/IEC 23008-2:2013 corresponded to the first version.

Rec. ITU-T H.265 | ISO/IEC 23008-2 version 2 refers to the integrated text containing format range extensions, scalability extensions, multiview extensions, additional supplement enhancement information, and corrections to various minor defects in the prior content of the specification. The second edition published by ISO/IEC as ISO/IEC 23008-2:2015 corresponded to the second version.

Rec. ITU-T H.265 | ISO/IEC 23008-2 version 3 refers to the integrated text additionally containing 3D extensions, additional supplement enhancement information, and corrections to various minor defects in the prior content of the specification.

Rec. ITU-T H.265 | ISO/IEC 23008-2 version 4 refers to the integrated text additionally containing screen content coding extensions, additional supplement enhancement information, and corrections to various minor defects in the prior content of the specification. The third edition published by ISO/IEC as ISO/IEC 23008-2:2017 corresponds to the fourth version.

Profiles, tiers, and levels

This document is designed to be generic in the sense that it serves a wide range of applications, bit rates, resolutions, qualities, and services. Applications should cover, among other things, digital storage media, television broadcasting, and real-time communications. In the course of creating this document, various requirements from typical applications have been considered, necessary algorithmic elements have been developed, and these have been integrated into a single syntax. Hence, this document will facilitate video data interchange among different applications.

Considering the practicality of implementing the full syntax of this document, however, a limited number of subsets of the syntax are also stipulated by means of “profiles”, “tiers”, and “levels”. These and other related terms are formally defined in Clause 3.

A “profile” is a subset of the entire bitstream syntax that is specified in this document. Within the bounds imposed by the syntax of a given profile it is still possible to require a very large variation in the performance of encoders and decoders depending upon the values taken by syntax elements in the bitstream such as the specified size of the decoded pictures. In many applications, it is currently neither practical nor economic to implement a decoder capable of dealing with all hypothetical uses of the syntax within a particular profile.

In order to deal with this problem, “tiers” and “levels” are specified within each profile. A level of a tier is a specified set of constraints imposed on values of the syntax elements in the bitstream. These constraints may be simple limits on values. Alternatively they may take the form of constraints on arithmetic combinations of values (e.g. picture width multiplied by picture height multiplied by number of pictures decoded per second). A level specified for a lower tier is more constrained than a level specified for a higher tier.

Coded video content conforming to this document uses a common syntax. In order to achieve a subset of the complete syntax, flags, parameters, and other syntax elements are included in the bitstream that signal the presence or absence of syntactic elements that occur later in the bitstream.

Overview of the design characteristics

The coded representation specified in the syntax is designed to enable a high compression capability for a desired image or video quality. The algorithm is typically not lossless, as the exact source sample values are typically not preserved through the encoding and decoding processes. A number of techniques may be used to achieve highly efficient compression. Encoding algorithms (not specified in this Recommendation | International Standard) may select between inter and intra coding for block-shaped regions of each picture. Inter coding uses motion vectors for block-based inter prediction

to exploit temporal statistical dependencies between different pictures. Intra coding uses various spatial prediction modes to exploit spatial statistical dependencies in the source signal for a single picture. Motion vectors and intra prediction modes may be specified for a variety of block sizes in the picture. The prediction residual may then be further compressed using a transform to remove spatial correlation inside the transform block before it is quantized, producing a possibly irreversible process that typically discards less important visual information while forming a close approximation to the source samples. Finally, the motion vectors or intra prediction modes may also be further compressed using a variety of prediction mechanisms, and, after prediction, are combined with the quantized transform coefficient information and encoded using arithmetic coding.

How to read this document

It is suggested that the reader start with Clause 1 (Scope) and move on to Clause 3 (Terms and definitions). Clause 6 should be read for the geometrical relationship of the source, input, and output of the decoder. Clause 7 (Syntax and semantics) specifies the order to parse syntax elements from the bitstream. See 7.1 to 7.3 for syntactical order and see 7.4 for semantics; e.g. the scope, restrictions, and conditions that are imposed on the syntax elements. The actual parsing for most syntax elements is specified in Clause 9 (Parsing process). Clause 10 (Sub-bitstream extraction process) specifies the sub-bitstream extraction process. Finally, Clause 8 (Decoding process) specifies how the syntax elements are mapped into decoded samples. Throughout reading this document, the reader should refer to Clauses 2 (Normative references), 4 (Abbreviations), and 5 (Conventions) as needed. Annexes A through I also form an integral part of this document.

Annex A specifies profiles each being tailored to certain application domains, and defines the so-called tiers and levels of the profiles. Annex B specifies syntax and semantics of a byte stream format for delivery of coded video as an ordered stream of bytes. Annex C specifies the hypothetical reference decoder, bitstream conformance, decoder conformance, and the use of the hypothetical reference decoder to check bitstream and decoder conformance. Annex D specifies syntax and semantics for supplemental enhancement information message payloads. Annex E specifies syntax and semantics of the video usability information parameters of the sequence parameter set. Annex F specifies general multi-layer support for bitstreams and decoders. Annex G contains support for multiview coding. Annex H contains support for scalability. Annex I contains support for 3D coding.

Throughout this document, statements appearing with the preamble “NOTE” are informative and are not an integral part of this document.

Information technology — High efficiency coding and media delivery in heterogeneous environments —

Part 2: High efficiency video coding

1 Scope

This document specifies high efficiency video coding.

2 Normative references

The following documents are referred to in the text in such a way that some or all of their content constitutes requirements of this document. For dated references, only the edition cited applies. For undated references, the latest edition of the referenced document (including any amendments) applies.

ISO 11664-1, *Colorimetry — Part 1: CIE standard colorimetric observers*

ISO 12232, *Photography — Digital still cameras — Determination of exposure index, ISO speed ratings, standard output sensitivity, and recommended exposure index*

ISO/IEC 10646, *Information technology — Universal Coded Character Set (UCS)*

ISO/IEC 11578, *Information technology — Open Systems Interconnection — Remote Procedure Call (RPC)*

ISO/IEC 23001-11, *Information technology — MPEG Systems technologies — Part 11: Energy-efficient media consumption (green metadata)*

IETF RFC 1321, *The MD5 Message-Digest Algorithm*

IETF RFC 5646, *Tags for Identifying Languages*

Recommendation ITU-T T.35, *Procedure for the allocation of ITU-T defined codes for non-standard facilities*

CEN/TR 13233, *Advanced technical ceramics — Notations and symbols*

3 Terms and definitions

For the purposes of this document, the terms and definitions given in CEN/TR 13233 and the following apply.

ISO and IEC maintain terminological databases for use in standardization at the following addresses:

- IEC Electropedia: available at <http://www.electropedia.org/>
- ISO Online browsing platform: available at <http://www.iso.org/obp>

3.1

access unit

set of *NAL units* (3.84) that are associated with each other according to a specified classification rule, are consecutive in *decoding order* (3.44), and contain exactly one *coded picture* (3.26) with *nuh_layer_id* equal to 0

Note 1 to entry: In addition to containing the *VCL NAL units* (3.166) of the coded picture with *nuh_layer_id* equal to 0, an access unit may also contain non-VCL NAL units. The decoding of an access unit with the decoding process specified in Clause 8 always results in a decoded picture with *nuh_layer_id* equal to 0.

Note 2 to entry: An access unit is defined differently in Annex F and does not need to contain a coded picture with *nuh_layer_id* equal to 0.

3.2

AC transform coefficient

transform coefficient (3.160) for which the *frequency index* (3.57) in at least one of the two dimensions is non-zero

3.3

associated non-VCL NAL unit

non-VCL NAL unit (3.88) (when present) for a *VCL NAL unit* (3.166) where the VCL NAL unit is the *associated VCL NAL unit* (3.5) of the non-VCL NAL unit

3.4

associated IRAP picture

previous *IRAP picture* (3.66) in *decoding order* (3.44) (when present)

3.5

associated VCL NAL unit

preceding *VCL NAL unit* (3.166) in *decoding order* (3.44) for a *non-VCL NAL unit* (3.88) with *nal_unit_type* equal to EOS_NUT, EOB_NUT, FD_NUT, or SUFFIX_SEI_NUT, or in the ranges of RSV_NVCL45..RSV_NVCL47 or UNSPEC56..UNSPEC63; or otherwise, the next VCL NAL unit in decoding order

3.6

base layer

layer in which all *NAL units* (3.84) have *nuh_layer_id* equal to 0

3.7

bin

one bit of a *bin string* (3.10)

3.8

binarization

set of *bin strings* (3.10) for all possible values of a *syntax element* (3.149)

3.9

binarization process

unique mapping process of all possible values of a *syntax element* (3.149) onto a set of *bin strings* (3.10)

3.10

bin string

intermediate binary representation of values of *syntax elements* (3.149) from the *binarization* (3.8) of the syntax element

3.11

bi-predictive (B) slice

slice (3.132) that is decoded using *intra prediction* (3.64) or using *inter prediction* (3.62) with at most two *motion vectors* (3.82) and *reference indices* (3.119) to predict the sample values of each *block* (3.13)

3.12**bitstream**

sequence of bits, in the form of a *NAL unit stream* (3.85) or a *byte stream* (3.20), that forms the representation of *coded pictures* (3.25) and associated data forming one or more *CVSs* (3.29)

3.13**block**

MxN (M-column by N-row) array of samples or an MxN array of *transform coefficients* (3.160)

3.14**broken link**

location in a *bitstream* (3.12) at which it is indicated that some subsequent *pictures* (3.98) in *decoding order* (3.44) may contain serious visual artefacts due to unspecified operations performed in the generation of the bitstream

3.15**broken link access (BLA) access unit**

access unit (3.1) in which the *coded picture* (3.26) with *nuh_layer_id* equal to 0 is a *BLA picture* (3.16)

3.16**broken link access (BLA) picture**

IRAP picture (3.66) for which each *VCL NAL unit* (3.166) has *nal_unit_type* equal to BLA_W_LP, BLA_W_RADL, or BLA_N_LP

Note 1 to entry: A BLA picture does not refer to any pictures other than itself for *inter prediction* (3.62) in its *decoding process* (3.45), and may be the first picture in the *bitstream* (3.12) in decoding order, or may appear later in the bitstream. Each BLA picture begins a new *CVS* (3.29), and has the same effect on the decoding process as an *IDR picture* (3.60). However, a BLA picture contains *syntax elements* (3.149) that specify a non-empty *RPS* (3.124). When a BLA picture for which each VCL NAL unit has *nal_unit_type* equal to BLA_W_LP, it may have associated RASL pictures, which are not output by the decoder and may not be decodable, as they may contain references to pictures that are not present in the bitstream. When a BLA picture for which each VCL NAL unit has *nal_unit_type* equal to BLA_W_LP, it may also have associated RADL pictures, which are specified to be decoded. When a BLA picture for which each VCL NAL unit has *nal_unit_type* equal to BLA_W_RADL, it does not have associated RASL pictures but may have associated RADL pictures. When a BLA picture for which each VCL NAL unit has *nal_unit_type* equal to BLA_N_LP, it does not have any associated leading pictures.

3.17**buffering period**

set of *access units* (3.1) starting with an *access unit* that contains a buffering period SEI message and containing all subsequent access units in *decoding order* (3.44) up to but not including the next access unit (when present) that contains a buffering period SEI message

3.18**byte**

sequence of 8 bits, within which, when written or read as a sequence of bit values, the left-most and right-most bits represent the most and least significant bits, respectively

3.19**byte-aligned**

position in a *bitstream* (3.12) is byte-aligned when the position is an integer multiple of 8 bits from the position of the first bit in the *bitstream* and a bit or *byte* (3.18) or *syntax element* (3.149) is said to be byte-aligned when the position at which it appears in a *bitstream* is byte-aligned

3.20**byte stream**

sequence of bytes forming an encapsulation of a *NAL unit stream* (3.85) into a format containing *start code prefixes* (3.137) and *NAL units* (3.84)

Note 1 to entry: See Annex B.

3.21

chroma

Cb

Cr

sample array or single sample representing one of the two colour difference signals related to the primary colours

Note 1 to entry: The term chroma is used rather than the term chrominance in order to avoid the implication of the use of linear light transfer characteristics that is often associated with the term chrominance.

3.22

clean random access (CRA) access unit

access unit (3.1) in which the *coded picture* (3.24) with *nuh_layer_id* equal to 0 is a *CRA picture* (3.23)

3.23

clean random access (CRA) picture

IRAP picture (3.66) for which each *VCL NAL unit* (3.166) has *nal_unit_type* equal to CRA_NUT

Note 1 to entry: A CRA picture does not refer to any pictures other than itself for inter prediction in its decoding process, and may be the first picture in the bitstream in decoding order, or may appear later in the bitstream. A CRA picture may have associated RADL or RASL pictures. As with a BLA picture, a CRA picture may contain syntax elements that specify a non-empty *RPS* (3.124). When a CRA picture has *NoRaslOutputFlag* equal to 1, the associated RASL pictures are not output by the decoder, because they may not be decodable, as they may contain references to pictures that are not present in the bitstream.

3.24

coded picture

coded representation of a picture containing all coding tree units of the picture

3.25

coded picture buffer

CPB

first-in first-out buffer containing *decoding units* (3.44) in *decoding order* (3.42) specified in the *hypothetical reference decoder* (3.56) in Annex C

3.26

coded representation

data element as represented in its coded form

3.27

coded slice segment NAL unit

NAL unit (3.84) that has *nal_unit_type* in the range of TRAIL_N to RASL_R, inclusive, or in the range of BLA_W_LP to RSV_IRAP_VCL23, inclusive, which indicates that the NAL unit contains a coded *slice segment* (3.134)

3.28

coded layer-wise video sequence

CLVS

sequence of *pictures* (3.94) and the associated *non-VCL NAL units* (3.97) of the base layer of a *CVS* (3.29)

3.29

coded video sequence

CVS

sequence of *access units* (3.1) that consists, in *decoding order* (3.42), of an *IRAP access unit* (3.65) with *NoRaslOutputFlag* equal to 1, followed by zero or more access units that are not IRAP access units with *NoRaslOutputFlag* equal to 1, including all subsequent access units up to but not including any subsequent access unit that is an IRAP access unit with *NoRaslOutputFlag* equal to 1

Note 1 to entry: An IRAP access unit may be an IDR access unit, a BLA access unit, or a CRA access unit. The value of *NoRaslOutputFlag* is equal to 1 for each IDR access unit, each BLA access unit, and each CRA access unit that is the first access unit in the bitstream in decoding order, is the first access unit that follows an end of sequence NAL unit in decoding order, or has *HandleCraAsBlaFlag* equal to 1.

3.30**coded video sequence group
CVSG**

one or more consecutive *CVSs* (3.29) in *decoding order* (3.42) that collectively consist of an *IRAP access unit* (3.65) that activates a VPS RBSP *firstVpsRbsp* that was not already active followed by all subsequent access units, in decoding order, for which *firstVpsRbsp* is the active VPS RBSP up to the end of the *bitstream* (3.12) or up to but excluding the access unit that activates a different VPS RBSP than *firstVpsRbsp*, whichever is earlier in decoding order

3.31**coding block**

$N \times N$ *block* (3.13) of samples for some value of N such that the division of a *coding tree block* (3.32) into coding blocks is a *partitioning* (3.93)

3.32**coding tree block**

$N \times N$ *block* (3.13) of samples for some value of N such that the division of a *component* (3.35) into coding tree blocks is a *partitioning* (3.93)

3.33**coding tree unit**

coding tree block (3.32) of *luma* (3.81) samples, two corresponding coding tree blocks of *chroma* (3.20) samples of a *picture* (3.94) that has three sample arrays, or a coding tree block of samples of a monochrome *picture* or a picture that is coded using three separate colour planes and *syntax structures* (3.150) used to code the samples

3.34**coding unit**

coding block (3.31) of *luma* (3.81) samples, two corresponding coding blocks of *chroma* (3.21) samples of a *picture* (3.94) that has three sample arrays, or a coding block of samples of a monochrome picture or a picture that is coded using three separate colour planes and *syntax structures* (3.150) used to code the samples

3.35**component**

array or single sample from one of the three arrays [*luma* (3.81) and two *chroma* (3.21)] that compose a *picture* (3.94) in 4:2:0, 4:2:2, or 4:4:4 colour format or the array or a single sample of the array that compose a picture in monochrome format

3.36**context variable**

variable specified for the adaptive binary arithmetic *decoding process* (3.43) of a *bin* (3.7) by an equation containing recently decoded bins

3.37**cropped decoded picture**

result of cropping a *decoded picture* (3.38) based on the conformance cropping window specified in the *SPS* (3.129) that is referred to by the corresponding *coded picture* (3.24)

3.38**decoded picture**

picture derived by applying the *decoding process* (3.43) to a *coded picture* (3.24)

3.39**decoded picture buffer****DPB**

buffer holding *decoded pictures* (3.38) for reference, output reordering, or output delay specified for the *hypothetical reference decoder* (3.56)

3.40

decoder

embodiment of a *decoding process* (3.43)

3.41

decoder under test

DUT

decoder (3.40) that is tested for conformance to this document by operating the *hypothetical stream scheduler* (3.57) to deliver a conforming *bitstream* (3.12) to the decoder and to the *hypothetical reference decoder* (3.56) and comparing the values and timing or order of the output of the two decoders

3.42

decoding order

order in which *syntax elements* (3.149) are processed by the *decoding process* (3.43)

3.43

decoding process

process specified in this document that reads a *bitstream* (3.12) and derives *decoded pictures* (3.38) from it

3.44

decoding unit

access unit (3.1) if SubPicHrdFlag is equal to 0 or a subset of an access unit otherwise, consisting of one or more *VCL NAL units* (3.166) in an access unit and the *associated non-VCL NAL units* (3.3)

3.45

dependent slice segment

slice segment (3.134) for which the values of some *syntax elements* (3.149) of the *slice segment header* (3.135) are inferred from the values for the preceding *independent slice segment* (3.58) in *decoding order* (3.42)

3.46

display process

process not specified in this document having, as its input, the *cropped decoded pictures* (3.37) that are the output of the *decoding process* (3.43)

3.47

elementary stream

sequence of one or more *bitstreams* (3.12)

Note 1 to entry: An elementary stream that consists of two or more bitstreams would typically have been formed by splicing together two or more bitstreams (or parts thereof).

3.48

emulation prevention byte

byte (3.18) equal to 0x03 that is present within a *NAL unit* (3.84) when the *syntax elements* (3.149) of the *bitstream* (3.12) form certain patterns of *byte* (3.18) values in a manner that ensures that no sequence of consecutive *byte-aligned* (3.19) bytes in the NAL unit can contain a *start code prefix* (3.137)

3.49

encoder

embodiment of an *encoding process* (3.50)

3.50

encoding process

process that produces a *bitstream* (3.12) conforming to this document

Note 1 to entry: This process is not specified in this document.

3.51**field**

assembly of alternative rows of samples of a *frame* (3.54)

3.52**filler data NAL unit**

NAL unit (3.85) with *nal_unit_type* equal to *FD_NUT*

3.53**flag**

variable or single-bit *syntax element* (3.149) that can take one of the two possible values, 0 and 1

3.54**frame**

composition of a top *field* (3.51) and a bottom field, where sample rows 0, 2, 4, ... originate from the top field and sample rows 1, 3, 5, ... originate from the bottom field

3.55**frequency index**

one-dimensional or two-dimensional index associated with a *transform coefficient* (3.160) prior to an *inverse transform* (3.68) part of the *decoding process* (3.43)

3.56**hypothetical reference decoder****HRD**

hypothetical *decoder* (3.40) model that specifies constraints on the variability of conforming *NAL unit streams* (3.85) or conforming *byte streams* (3.20) that an *encoding process* (3.52) may produce

3.57**hypothetical stream scheduler****HSS**

hypothetical delivery mechanism used for checking the conformance of a *bitstream* (3.12) or a *decoder* (3.40) with regards to the timing and data flow of the input of a bitstream into the *hypothetical reference decoder* (3.56)

3.58**independent slice segment**

slice segment (3.134) for which the values of the *syntax elements* (3.149) of the *slice segment header* (3.135) are not inferred from the values for a preceding slice segment

3.59**instantaneous decoding refresh (IDR) access unit**

access unit (3.1) in which the *coded picture* (3.24) with *nuh_layer_id* equal to 0 is an *IDR picture* (3.61)

3.60**instantaneous decoding refresh (IDR) picture**

IRAP picture (3.66) for which each *VCL NAL unit* (3.166) has *nal_unit_type* equal to *IDR_W_RADL* or *IDR_N_LP*

Note 1 to entry: An IDR picture does not refer to any pictures other than itself for inter prediction in its decoding process, and may be the first picture in the bitstream in decoding order, or may appear later in the bitstream. Each IDR picture is the first picture of a *CVS* (3.29) in decoding order. When an IDR picture for which each VCL NAL unit has *nal_unit_type* equal to *IDR_W_RADL*, it may have associated RADL pictures. When an IDR picture for which each VCL NAL unit has *nal_unit_type* equal to *IDR_N_LP*, it does not have any associated leading pictures. An IDR picture does not have associated RASL pictures.

3.61**inter coding**

coding of a *coding block* (3.31), *slice* (3.132), or *picture* (3.94) that uses *inter prediction* (3.62)

3.62

inter prediction

prediction (3.98) derived in a manner that is dependent on data elements (e.g. sample values or motion vectors) of one or more *reference pictures* (3.120)

Note 1 to entry: A prediction from a reference picture that is the current picture itself is also inter prediction.

3.63

intra coding

coding of a *coding block* (3.31), *slice* (3.132), or *picture* (3.94) that uses *intra prediction* (3.64)

3.64

intra prediction

prediction (3.98) derived from only data elements (e.g. sample values) of the same decoded *slice* (3.132) without referring to a *reference picture* (3.120)

3.65

intra random access point (IRAP) access unit

access unit (3.1) in which the *coded picture* (3.24) with *nuh_layer_id* equal to 0 is an *IRAP picture* (3.66)

3.66

intra random access point (IRAP) picture

coded picture (3.24) for which each *VCL NAL unit* (3.166) has *nal_unit_type* in the range of BLA_W_LP to RSV_IRAP_VCL23, inclusive

Note 1 to entry: An IRAP picture does not refer to any pictures other than itself for inter prediction in its decoding process, and may be a BLA picture, a CRA picture or an IDR picture. The first picture in the bitstream in decoding order must be an IRAP picture. Provided the necessary parameter sets are available when they need to be activated, the IRAP picture and all subsequent non-RASL pictures in decoding order can be correctly decoded without performing the decoding process of any pictures that precede the IRAP picture in decoding order. There may be pictures in a bitstream that do not refer to any pictures other than itself for inter prediction in its decoding process that are not IRAP pictures.

3.67

intra (I) slice

slice (3.136) that is decoded using *intra prediction* (3.64) only

3.68

inverse transform

part of the *decoding process* (3.43) by which a set of *transform coefficients* (3.160) are converted into spatial-domain values

3.69

layer

<scalable> set of *VCL NAL units* (3.166) that all have a particular value of *nuh_layer_id* and the *associated non-VCL NAL units* (3.3)

Note 1 to entry: Depending on the context, either the first layer concept or the second layer concept applies. This first layer concept is also referred to as a scalable layer, wherein a layer may be a spatial scalable layer, a quality scalable layer, a view, etc. A temporal true subset of a scalable layer is not referred to as a layer but referred to as a sub-layer or temporal sub-layer.

Note 2 to entry: See also *layer* (3.70).

3.70

layer

<coding> one of a set of syntactical structures having a hierarchical relationship

Note 1 to entry: This second layer concept is also referred to as a coding layer, wherein higher layers contain lower layers, and the coding layers are the *CVS* (3.29), picture, slice, slice segment, and coding tree unit layers.

Note 2 to entry: See also *layer* (3.69).

3.71**layer identifier list**

list of *nuh_layer_id* values that is associated with a *layer set* (3.72) or an *operation point* (3.89) and can be used as an input to the *sub-bitstream extraction process* (3.141)

3.72**layer set**

set of layers represented within a *bitstream* (3.12) created from another bitstream by operation of the *sub-bitstream extraction process* (3.141) with the another bitstream, the target highest TemporalId equal to 6, and the target *layer identifier list* (3.69) equal to the layer identifier list associated with the layer set as inputs

3.73**leading picture**

picture (3.94) that precedes the associated *IRAP picture* (3.66) in *output order* (3.90)

3.74**leaf**

terminating node of a *tree* (3.163) that is a root node of a tree of depth 0

3.75**level**

<constraint> defined set of constraints on values that may be taken by the *syntax elements* (3.149) and variables of this document

Note 1 to entry: The same set of levels is defined for all profiles, with most aspects of the definition of each level being in common across different profiles. Individual implementations may, within the specified constraints, support a different level for each supported profile.

3.76**level**

<transform coefficient> value of a *transform coefficient* (3.160) prior to *scaling* (3.128)

3.77**list 0 (list 1) motion vector**

motion vector (3.82) associated with a reference index pointing into reference picture list 0 (list 1)

3.78**list 0 (list 1) prediction**

inter prediction (3.62) of the content of a *slice* (3.132) using a reference index pointing into reference picture list 0 (list 1)

3.79**long-term reference picture**

picture (3.94) that is marked as “used for long-term reference”

3.80**long-term reference picture set**

two *RPS* (3.124) lists that may contain *long-term reference pictures* (3.79)

3.81**luma**

Y or L

sample array or single sample representing the monochrome signal related to the primary colours

Note 1 to entry: The term luma is used rather than the term luminance in order to avoid the implication of the use of linear light transfer characteristics that is often associated with the term luminance. The symbol L is sometimes used instead of the symbol Y to avoid confusion with the symbol y as used for vertical location.

3.82

motion vector

two-dimensional vector used for *inter prediction* (3.62) that provides an offset from the coordinates in the *decoded picture* (3.38) to the coordinates in a *reference picture* (3.120)

3.83

nested SEI message

SEI message that is contained in a scalable nesting SEI message

3.84

network abstraction layer (NAL) unit

syntax structure (3.150) containing an indication of the type of data to follow and *bytes* (3.18) containing that data in the form of an *RBSP* (3.116) interspersed as necessary with *emulation prevention bytes* (3.48)

3.85

network abstraction layer (NAL) unit stream

sequence of *NAL units* (3.84)

3.86

non-nested SEI message

SEI message that is not contained in a scalable nesting SEI message

3.87

non-reference picture

picture (3.94) that is marked as “unused for reference”

Note 1 to entry: A non-reference picture contains samples that cannot be used for inter prediction in the decoding process of subsequent pictures in decoding order. In other words, once a picture is marked as “unused for reference”, it can never be marked back as “used for reference”.

3.88

non-VCL NAL unit

NAL unit (3.84) that is not a *VCL NAL unit* (3.166)

3.89

operation point

bitstream (3.12) created from another bitstream by operation of the *sub-bitstream extraction process* (3.141) with another bitstream, a target highest TemporalId, and a target *layer identifier list* (3.71) as inputs

Note 1 to entry: If the target highest TemporalId of an operation point is equal to the greatest value of TemporalId in the layer set associated with the target layer identification list, the operation point is identical to the layer set. Otherwise it is a subset of the layer set.

3.90

output order

order in which the *decoded pictures* (3.38) are output from the *decoded picture buffer* (3.39)

3.91

output time

time when a *decoded picture* (3.38) is to be output as specified by the *HRD* (3.56) according to the output timing *DPB* (3.39) operation

3.92

parameter

syntax element of a *VPS* (3.167), *SPS* (3.129) or *PPS* (3.95), or the second word of the defined term *quantization parameter* (3.109)

3.93

partitioning

division of a set into subsets such that each element of the set is in exactly one of the subsets

3.94**picture**

array of *luma* (3.81) samples in monochrome format or an array of *luma* samples and two corresponding arrays of *chroma* (3.21) samples in 4:2:0, 4:2:2, and 4:4:4 colour format

Note 1 to entry: A picture may be either a frame or a field. However, in one *CVS* (3.29), either all pictures are frames or all pictures are fields.

3.95**picture parameter set****PPS**

syntax structure (3.150) containing *syntax elements* (3.149) that apply to zero or more entire *coded pictures* (3.24) as determined by a syntax element found in each *slice segment header* (3.135)

3.96**picture order count****POC**

variable that is associated with each *picture* (3.94), uniquely identifies the associated picture among all pictures in the *CVS* (3.29), and, when the associated picture is to be output from the *decoded picture buffer* (3.39), indicates the position of the associated picture in *output order* (3.90) relative to the output order positions of the other pictures in the same *CVS* that are to be output from the decoded picture buffer

3.97**picture unit**

set of *NAL units* (3.84) that contain all *VCL NAL units* (3.166) of a *coded picture* and their *associated non-VCL NAL units* (3.3)

3.98**prediction**

embodiment of the *prediction process* (3.100)

3.99**prediction block**

rectangular $M \times N$ *block* (3.13) of samples on which the same *prediction* (3.98) is applied

3.100**prediction process**

use of a *predictor* (3.103) to provide an estimate of the data element (e.g. sample value or motion vector) currently being decoded

3.101**prediction unit**

prediction block (3.99) of *luma* (3.81) samples, two corresponding prediction blocks of *chroma* (3.21) samples of a *picture* (3.94) that has three sample arrays, or a prediction block of samples of a monochrome picture or a picture that is coded using three separate colour planes and *syntax structures* (3.150) used to predict the prediction block samples

3.102**predictive (P) slice**

slice (3.132) that is decoded using *intra prediction* (3.64) or using *inter prediction* (3.62) with at most one *motion vector* (3.82) and *reference index* (3.119) to predict the sample values of each *block* (3.13)

3.103**predictor**

combination of specified values or previously decoded data elements (e.g. sample value or motion vector) used in the *decoding process* (3.43) of subsequent data elements

3.104**prefix SEI message**

SEI message that is contained in a *prefix SEI NAL unit* (3.105)

3.105

prefix SEI NAL unit

SEI NAL unit (3.148) that has *nal_unit_type* equal to PREFIX_SEI_NUT

3.106

profile

specified subset of the syntax of this document

3.107

pulse code modulation

PCM

coding of the samples of a *block* (3.13) by directly representing the sample values without *prediction* (3.98) or application of a transform

3.108

quadtree

tree (3.163) in which a parent node can be split into four child nodes, each of which may become parent node for another split into four child nodes

3.109

quantization parameter

variable used by the decoding process (3.43) for scaling of transform coefficient levels

3.110

random access

act of starting the decoding process for a *bitstream* (3.12) at a point other than the beginning of the stream

3.111

random access decodable leading (RADL) access unit

access unit (3.1) in which the *coded picture* (3.24) with *nuh_layer_id* equal to 0 is a *RADL picture* (3.112)

3.112

random access decodable leading (RADL) picture

coded picture for which each *VCL NAL unit* (3.166) has *nal_unit_type* equal to RADL_R or RADL_N

Note 1 to entry: All RADL pictures are leading pictures. RADL pictures are not used as reference pictures for the decoding process of trailing pictures of the same associated IRAP picture. When present, all RADL pictures precede, in decoding order, all trailing pictures of the same associated IRAP picture.

3.113

random access skipped leading (RASL) access unit

access unit (3.1) in which the *coded picture* with *nuh_layer_id* equal to 0 is a RASL picture

3.114

random access skipped leading (RASL) picture

coded picture (3.24) for which each *VCL NAL unit* (3.166) has *nal_unit_type* equal to RASL_R or RASL_N

Note 1 to entry: All RASL pictures are leading pictures of an associated BLA or CRA picture. When the associated IRAP picture has *NoRaslOutputFlag* equal to 1, the RASL picture is not output and may not be correctly decodable, as the RASL picture may contain references to pictures that are not present in the bitstream. RASL pictures are not used as reference pictures for the decoding process of non-RASL pictures. When present, all RASL pictures precede, in decoding order, all trailing pictures of the same associated IRAP picture.

3.115

raster scan

mapping of a rectangular two-dimensional pattern to a one-dimensional pattern such that the first entries in the one-dimensional pattern are from the first top row of the two-dimensional pattern scanned from left to right, followed similarly by the second, third, etc. rows of the pattern (going down) each scanned from left to right

3.116**raw byte sequence payload****RBSP**

syntax structure (3.150) containing an integer number of *bytes* (3.18) that is encapsulated in a *NAL unit* (3.84) and that is either empty or has the form of a *string of data bits* (3.140) containing *syntax elements* (3.149) followed by an *RBSP stop bit* (3.117) and zero or more subsequent bits equal to 0

3.117**raw byte sequence payload (RBSP) stop bit**

bit equal to 1 present within a *raw byte sequence payload (RBSP)* (3.116) after a *string of data bits* (3.140), for which the location of the end within an RBSP can be identified by searching from the end of the RBSP for the RBSP stop bit, which is the last non-zero bit in the RBSP

3.118**recovery point**

point in the *bitstream* (3.12) at which the recovery of an exact or an approximate representation of the *decoded pictures* (3.38) represented by the bitstream is achieved after a *random access* (3.110) or *broken link* (3.14)

3.119**reference index**

index into a *reference picture list* (3.121)

3.120**reference picture**

picture (3.94) that is a *short-term reference picture* (3.130) or a *long-term reference picture* (3.79)

Note 1 to entry: A reference picture contains samples that may be used for inter prediction in the decoding process of subsequent pictures in decoding order.

3.121**reference picture list**

list of *reference pictures* (3.94) that is used for *inter prediction* (3.62) of a *P slice* (3.102) or *B slice* (3.11)

Note 1 to entry: For the decoding process of a P slice, there is one reference picture list – reference picture list 0. For the decoding process of a B slice, there are two reference picture lists – reference picture list 0 and reference picture list 1.

3.122**reference picture list 0**

reference picture list (3.121) used for *inter prediction* (3.62) of a *P slice* (3.102) or the first reference picture list used for inter prediction of a *B slice* (3.11)

3.123**reference picture list 1**

second *reference picture list* (3.121) used for *inter prediction* (3.62) of a *B slice* (3.11)

3.124**reference picture set****RPS**

set of *reference pictures* (3.120) associated with a *picture* (3.94), consisting of all reference pictures that are prior to the associated picture in *decoding order* (3.42), that may be used for *inter prediction* (3.62) of the associated picture or any picture following the associated picture in decoding order

Note 1 to entry: The RPS of a picture consists of five RPS lists, three of which are to contain short-term reference pictures and the other two are to contain long-term reference pictures.

3.125

reserved

<value of a particular syntax element> that may be used in the future by ITU-T | ISO/IEC

Note 1 to entry: These values cannot be used in *bitstreams* (3.12) conforming to this document, but can be used in *bistreams* conforming to future editions of this document.

3.126

residual

decoded difference between a *prediction* (3.98) of a sample or data element and its decoded value

3.127

sample aspect ratio

ratio between the intended horizontal distance between the columns and the intended vertical distance between the rows of the *luma* (3.81) sample array in a *picture* (3.94), which is specified for assisting the *display process* (3.46) (not specified in this document) and expressed as *h:v*, where *h* is the horizontal width and *v* is the vertical height, in arbitrary units of spatial distance

3.128

scaling

process of multiplying *transform coefficient levels* (3.161) by a factor, resulting in *transform coefficients* (3.160)

3.129

sequence parameter set

SPS

syntax structure (3.150) containing *syntax elements* (3.149) that apply to zero or more entire *CVSs* (3.29) as determined by the content of a syntax element found in the *PPS* (3.95) referred to by a syntax element found in each *slice segment header* (3.135)

3.130

short-term reference picture

picture (3.94) that is marked as “used for short-term reference”

3.131

short-term reference picture set

three *RPS* (3.124) lists that may contain short-term reference pictures

3.132

slice

integer number of *coding tree units* (3.33) contained in one *independent slice segment* (3.58) and all subsequent *dependent slice segments* (3.45) (if any) that precede the next independent slice segment (if any) within the same *access unit* (3.1)

3.133

slice header

slice segment header (3.135) of the *independent slice segment* (3.153) that is a current *slice segment* (3.134) or the most recent independent slice segment that precedes a current *dependent slice segment* (3.45) in *decoding order* (3.42)

3.134

slice segment

integer number of *coding tree units* (3.33) ordered consecutively in the *tile scan* (3.161) and contained in a single *NAL unit* (3.84)

3.135

slice segment header

part of a coded *slice segment* (3.134) containing the data elements pertaining to the first or all *coding tree units* (3.33) represented in the slice segment

3.136 source

term used to describe the video material or some of its attributes before encoding

3.137 start code prefix

unique sequence of three *bytes* (3.18) equal to 0x000001 embedded in the *byte stream* (3.20) as a prefix to each *NAL unit* (3.84)

Note 1 to entry: The location of a start code prefix can be used by a decoder to identify the beginning of a new NAL unit and the end of a previous NAL unit. Emulation of start code prefixes is prevented within NAL units by the inclusion of emulation prevention bytes.

3.138 step-wise temporal sub-layer access (STSA) access unit

access unit (3.1) in which the *coded picture* (3.24) with *nuh_layer_id* equal to 0 is an *STSA picture* (3.139)

3.139 step-wise temporal sub-layer access (STSA) picture

coded picture (3.24) for which each *VCL NAL unit* (3.166) has *nal_unit_type* equal to STSA_R or STSA_N

Note 1 to entry: An STSA picture does not use pictures with the same *TemporalId* as the STSA picture for inter prediction reference. Pictures following an STSA picture in decoding order with the same *TemporalId* as the STSA picture do not use pictures prior to the STSA picture in decoding order with the same *TemporalId* as the STSA picture for inter prediction reference. An STSA picture enables up-switching, at the STSA picture, to the sub-layer containing the STSA picture, from the immediately lower sub-layer. STSA pictures must have *TemporalId* greater than 0.

3.140 string of data bits SODB

sequence of some number of bits representing *syntax elements* (3.149) present within a *raw byte sequence payload* (3.116) prior to the *raw byte sequence payload stop bit* (3.117), where the left-most bit is considered to be the first and most significant bit, and the right-most bit is considered to be the last and least significant bit

3.141 sub-bitstream extraction process

specified process by which *NAL units* (3.84) in a *bitstream* (3.12) that do not belong to a target set, determined by a target highest *TemporalId* and a target *layer identifier list* (3.71), are removed from the bitstream, with the output sub-bitstream consisting of the NAL units in the bitstream that belong to the target set

3.142 sub-layer

temporal sub-layer

temporal scalable layer of a temporal scalable *bitstream* (3.12), consisting of *VCL NAL units* (3.166) with a particular value of the *TemporalId* variable and the associated *non-VCL NAL units* (3.88)

3.143 sub-layer non-reference (SLNR) picture

picture (3.94) that contains samples that cannot be used for *inter prediction* (3.62) in the *decoding process* (3.43) of subsequent pictures of the same *sub-layer* (3.142) in *decoding order* (3.42)

Note 1 to entry: Samples of an SLNR picture may be used for inter prediction in the decoding process of subsequent pictures of higher sub-layers in decoding order.

3.144

sub-layer reference picture

picture (3.93) that contains samples that may be used for *inter prediction* (3.62) in the *decoding process* (3.43) of subsequent pictures of the same *sub-layer* (3.142) in *decoding order* (3.42)

Note 1 to entry: Samples of a sub-layer reference picture may also be used for inter prediction in the decoding process of subsequent pictures of higher sub-layers in decoding order.

3.145

sub-layer representation

subset of the *bitstream* (3.12) consisting of *NAL units* (3.84) of a particular *sub-layer* (3.14) and the lower sub-layers

3.146

suffix SEI message

SEI message that is contained in a *suffix SEI NAL unit* (3.147)

3.147

suffix SEI NAL unit

SEI NAL unit (3.148) that has *nal_unit_type* equal to SUFFIX_SEI_NUT

3.148

supplemental enhancement information (SEI) NAL unit

NAL unit (3.84) that has *nal_unit_type* equal to PREFIX_SEI_NUT or SUFFIX_SEI_NUT

3.149

syntax element

element of data represented in the *bitstream* (3.12)

3.150

syntax structure

zero or more *syntax elements* (3.149) present together in the *bitstream* (3.12) in a specified order

3.151

temporal sub-layer access (TSA) access unit

access unit (3.1) in which the *coded picture* (3.24) with *nuh_layer_id* equal to 0 is a *TSA picture* (3.152)

3.152

temporal sub-layer access (TSA) picture

coded picture (3.24) for which each *VCL NAL unit* (3.166) has *nal_unit_type* equal to TSA_R or TSA_N

Note 1 to entry: to entry: A TSA picture and pictures following the TSA picture in decoding order do not use pictures prior to the TSA picture in decoding order with *TemporalId* greater than or equal to that of the TSA picture for inter prediction reference. A TSA picture enables up-switching, at the TSA picture, to the sub-layer containing the TSA picture or any higher sub-layer, from the immediately lower sub-layer. TSA pictures must have *TemporalId* greater than 0.

3.153

tier

specified category of *level* (3.75) constraints imposed on values of the *syntax elements* (3.149) in the *bitstream* (3.12)

Note 1 to entry: The level constraints are nested within a tier and a *decoder* (3.40) conforming to a certain tier and level would be capable of decoding all bitstreams that conform to the same tier or the lower tier of that level or any level below it.

3.154

tile

rectangular region of *coding tree blocks* (3.32) within a particular *tile column* (3.159) and a particular *tile row* (3.156) in a *picture* (3.94)

3.155**tile column**

rectangular region of *coding tree blocks* (3.32) having a height equal to the height of the *picture* (3.94) and a width specified by *syntax elements* (3.149) in the *picture parameter set* (3.95)

3.156**tile row**

rectangular region of *coding tree blocks* (3.32) having a height specified by *syntax elements* (3.149) in the *picture parameter set* (3.95) and a width equal to the width of the *picture* (3.94)

3.157**tile scan**

specific sequential ordering of *coding tree blocks* (3.32) *partitioning* (3.93) a *picture* (3.94) in which the coding tree blocks are ordered consecutively in coding tree block *raster scan* (3.115) in a *tile* (3.154)

Note 1 to entry: Tiles in a picture are ordered consecutively in a raster scan of the tiles of the picture.

3.158**trailing picture**

non-IRAP *picture* (3.94) that follows the *associated IRAP picture* (3.4) in *output order* (3.90)

Note 1 to entry: Trailing pictures associated with an IRAP picture also follow the IRAP picture in decoding order. Pictures that follow the associated IRAP picture in output order and precede the associated IRAP picture in decoding order are not allowed.

3.159**transform block**

rectangular MxN *block* (3.13) of samples on which the same transform is applied

3.160**transform coefficient**

scalar quantity, considered to be in a frequency domain, that is associated with a particular one-dimensional or two-dimensional *frequency index* (3.55) in an *inverse transform* (3.68) part of the *decoding process* (3.43)

3.161**transform coefficient level**

integer quantity representing the value associated with a particular two-dimensional frequency index in the decoding process prior to scaling for computation of a transform coefficient value

3.162**transform unit**

transform block (3.159) of *luma* (3.81) samples of size 8×8, 16×16, or 32×32 or four transform blocks of *luma* samples of size 4×4, two corresponding *transform blocks* of *chroma* (3.21) samples of a *picture* (3.94) in 4:2:0 colour format; or *transform block* of *luma* samples of size 8×8, 16×16, or 32×32, and four corresponding *transform blocks* of *chroma* samples, or four *transform blocks* of *luma* samples of size 4×4, and four corresponding *transform blocks* of *chroma* samples of a *picture* in 4:2:2 colour format; or *transform block* of *luma* samples of size 4×4, 8×8, 16×16, or 32×32, and two corresponding *transform blocks* of *chroma* samples of a *picture* in 4:4:4 colour format that is not coded using three separate colour planes and *syntax structures* (3.150) used to transform the *transform block* samples; or *transform block* of *luma* samples of size 8×8, 16×16, or 32×32 or four *transform blocks* of *luma* samples of size 4×4 of a monochrome *picture* or a *picture* in 4:4:4 colour format that is coded using three separate colour planes; and the associated *syntax structures* used to transform the *transform block* samples

3.163**tree**

finite set of nodes with a unique root node

3.164

universal unique identifier

UUID

identifier that is unique with respect to the space of all universal unique identifiers

3.165

unspecified

<value of a particular syntax element> not to be used in the future by ITU-T/ISO/IEC

Note 1 to entry: These values have no specific meaning in this document and will not be used in future editions of this document.

3.166

video coding layer (VCL) NAL unit

collective term for *coded slice segment NAL units* and the subset of *NAL units* that have *reserved* values of *nal_unit_type* that are classified as VCL NAL units in this document.

3.167

video parameter set

VPS

syntax structure (3.150) containing *syntax elements* (3.149) that apply to zero or more entire *CVSs* (3.29) as determined by the content of a syntax element found in the *SPS* (3.129) referred to by a syntax element found in the *PPS* (3.95) referred to by a syntax element found in each *slice segment header* (3.135)

3.168

z-scan order

specified sequential ordering of *blocks* (3.13) *partitioning* (3.93) a *picture* (3.94) where the order is identical to *coding tree block raster scan* of the *picture* when the *blocks* are of the same size as *coding tree blocks* and, when the *blocks* are of a smaller size than *coding tree blocks*, i.e. *coding tree blocks* are further partitioned into smaller *coding blocks*, the order traverses from *coding tree block* to *coding tree block* in *coding tree block raster scan* of the *picture*, and inside each *coding tree block*, which may be divided into *quadtrees* hierarchically to lower levels, the order traverses from *quadtree* to *quadtree* of a particular level in *quadtree-of-the-particular-level raster scan* of the *quadtree* of the immediately higher level

4 Abbreviated terms

B	bi-predictive
BLA	broken link access
CABAC	context-based adaptive binary arithmetic coding
CB	coding block
CBR	constant bit rate
CLVS	coded layer-wise video sequence
CPB	coded picture buffer
CRA	clean random access
CTB	coding tree block
CTU	coding tree unit
CU	coding unit
CVS	coded video sequence
CVSG	coded video sequence group
DPB	decoded picture buffer
DRAP	dependent random access point
DUT	decoder under test
EG	exponential-Golomb
FIFO	first-in, first-out
FIR	finite impulse response
FL	fixed-length
GDR	gradual decoding refresh
HRD	hypothetical reference decoder
HSS	hypothetical stream scheduler
I	intra
IDR	instantaneous decoding refresh
INBLD	independent non-base layer decoding
IRAP	intra random access point
LPS	least probable symbol
LSB	least significant bit
MPS	most probable symbol
MSB	most significant bit
MVP	motion vector prediction
NAL	network abstraction layer
P	predictive
PB	prediction block
PCM	pulse code modulation

ISO/IEC 23008-2:2017(E)

PPS	picture parameter set
PU	prediction unit
QP	quantization parameter
RADL	random access decodable leading (picture)
RASL	random access skipped leading (picture)
RBSP	raw byte sequence payload
RPS	reference picture set
SEI	supplemental enhancement information
SLNR	sub-layer non-reference (picture)
SODB	string of data bits
SPS	sequence parameter set
STSA	step-wise temporal sub-layer access
TB	transform block
TR	truncated rice
TSA	temporal sub-layer access
TU	transform unit
UCS	universal coded character set
UTF	ucs transmission format
UUID	universal unique identifier
VBR	variable bit rate
VCL	video coding layer
VPS	video parameter set
VUI	video usability information

5 Conventions

5.1 General

When the word “shall” is used to express a mandatory constraint on the values of syntax elements or on the results obtained by operation of the specified decoding process, it is the responsibility of the encoder to ensure that the constraint is fulfilled. When “shall” is used in reference to operations performed by the decoding process, any decoding process that produces identical cropped decoded pictures to those output from the decoding process described in this document conforms to the decoding process requirements of this document.

NOTE The mathematical operators used in this document are similar to those used in the C programming language. However, the results of integer division and arithmetic shift operations are defined more precisely, and additional operations are defined, such as exponentiation and real-valued division. Numbering and counting conventions generally begin from 0, e.g. “the first” is equivalent to the 0-th, “the second” is equivalent to the 1-th, etc.

5.2 Arithmetic operators

+	addition
-	subtraction (as a two-argument operator) or negation (as a unary prefix operator)
*	multiplication, including matrix multiplication
x^y	exponentiation. Specifies x to the power of y . In other contexts, such notation is used for superscripting not intended for interpretation as exponentiation.
/	integer division with truncation of the result toward zero. For example, $7 / 4$ and $-7 / -4$ are truncated to 1 and $-7 / 4$ and $7 / -4$ are truncated to -1.
÷	used to denote division in mathematical equations where no truncation or rounding is intended.
$\frac{x}{y}$	used to denote division in mathematical equations where no truncation or rounding is intended.
$\sum_{i=x}^y f(i)$	the summation of $f(i)$ with i taking all integer values from x up to and including y .
$x \% y$	modulus. Remainder of x divided by y , defined only for integers x and y with $x \geq 0$ and $y > 0$.

5.3 Logical operators

$x \&\& y$	Boolean logical “and” of x and y
$x \ \ y$	Boolean logical “or” of x and y
!	Boolean logical “not”
$x ? y : z$	if x is TRUE or not equal to 0, evaluates to the value of y ; otherwise, evaluates to the value of z .

5.4 Relational operators

>	greater than
>=	greater than or equal to
<	less than
<=	less than or equal to
= =	equal to
!=	not equal to

When a relational operator is applied to a syntax element or variable that has been assigned the value “na” (not applicable), the value “na” is treated as a distinct value for the syntax element or variable. The value “na” is considered not to be equal to any other value.

5.5 Bit-wise operators

&	bit-wise “and”. When operating on integer arguments, operates on a two's complement representation of the integer value. When operating on a binary argument that contains fewer bits than another argument, the shorter argument is extended by adding more significant bits equal to 0.
	bit-wise “or”. When operating on integer arguments, operates on a two's complement representation of the integer value. When operating on a binary argument that contains

fewer bits than another argument, the shorter argument is extended by adding more significant bits equal to 0.

- ^ bit-wise “exclusive or”. When operating on integer arguments, operates on a two's complement representation of the integer value. When operating on a binary argument that contains fewer bits than another argument, the shorter argument is extended by adding more significant bits equal to 0.
- x >> y arithmetic right shift of a two's complement integer representation of x by y binary digits. This function is defined only for non-negative integer values of y. Bits shifted into the MSBs as a result of the right shift have a value equal to the MSB of x prior to the shift operation.
- x << y arithmetic left shift of a two's complement integer representation of x by y binary digits. This function is defined only for non-negative integer values of y. Bits shifted into the LSBs as a result of the left shift have a value equal to 0.

5.6 Assignment operators

- = assignment operator
- ++ increment, i.e. x++ is equivalent to x = x + 1; when used in an array index, evaluates to the value of the variable prior to the increment operation.
- decrement, i.e. x-- is equivalent to x = x - 1; when used in an array index, evaluates to the value of the variable prior to the decrement operation.
- += increment by amount specified, i.e. x += 3 is equivalent to x = x + 3, and x += (-3) is equivalent to x = x + (-3).
- decrement by amount specified, i.e. x -= 3 is equivalent to x = x - 3, and x -= (-3) is equivalent to x = x - (-3).

5.7 Range notation

x = y..z x takes on integer values starting from y to z, inclusive, with x, y, and z being integer numbers and z being greater than y.

5.8 Mathematical functions

$$\text{Abs}(x) = \begin{cases} x & ; x \geq 0 \\ -x & ; x < 0 \end{cases} \tag{5-1}$$

Ceil(x) the smallest integer greater than or equal to x (5-2)

$$\text{Clip1}_Y(x) = \text{Clip3}(0, (1 \ll \text{BitDepth}_Y) - 1, x) \tag{5-3}$$

$$\text{Clip1}_C(x) = \text{Clip3}(0, (1 \ll \text{BitDepth}_C) - 1, x) \tag{5-4}$$

$$\text{Clip3}(x, y, z) = \begin{cases} x & ; z < x \\ y & ; z > y \\ z & ; \text{otherwise} \end{cases} \tag{5-5}$$

Cos(x) the trigonometric cosine function operating on an argument x in units of radians (5-6)

Floor(x) the largest integer less than or equal to x (5-7)

$$\text{GetCurrMsb}(cl, pl, pm, ml) = \begin{cases} pm + ml & ; pl - cl \geq ml / 2 \\ pm - ml & ; cl - pl > ml / 2 \\ pm & ; \text{otherwise} \end{cases} \quad (5-8)$$

$\text{Ln}(x)$ the natural logarithm of x (the base- e logarithm, where e is the natural logarithm base constant 2.718 281 828...)
(5-9)

$\text{Log}_2(x)$ the base-2 logarithm of x
(5-10)

$\text{Log}_{10}(x)$ the base-10 logarithm of x
(5-11)

$$\text{Min}(x, y) = \begin{cases} x & ; x \leq y \\ y & ; x > y \end{cases} \quad (5-12)$$

$$\text{Max}(x, y) = \begin{cases} x & ; x \geq y \\ y & ; x < y \end{cases} \quad (5-13)$$

$$\text{Round}(x) = \text{Sign}(x) * \text{Floor}(\text{Abs}(x) + 0.5) \quad (5-14)$$

$$\text{Sign}(x) = \begin{cases} 1 & ; x > 0 \\ 0 & ; x = 0 \\ -1 & ; x < 0 \end{cases} \quad (5-15)$$

$$\text{Sqrt}(x) = \sqrt{x} \quad (5-16)$$

$$\text{Swap}(x, y) = (y, x) \quad (5-17)$$

5.9 Order of operation precedence

When order of precedence in an expression is not indicated explicitly by use of parentheses, the following rules apply:

- Operations of a higher precedence are evaluated before any operation of a lower precedence.
- Operations of the same precedence are evaluated sequentially from left to right.

Table 5-1 specifies the precedence of operations from highest to lowest; a higher position in the table indicates a higher precedence.

NOTE For those operators that are also used in the C programming language, the order of precedence used in this document is the same as used in the C programming language.

Table 5-1 — Operation precedence from highest (at top of table) to lowest (at bottom of table)

operations (with operands x, y, and z)
"x++", "x--"
"!x", "-x" (as a unary prefix operator)
"xy"
"x * y", "x / y", "x ÷ y", " $\frac{x}{y}$ ", "x % y"

"x + y", "x - y" (as a two-argument operator), " $\sum_{i=x}^y f(i)$ "
"x << y", "x >> y"
"x < y", "x <= y", "x > y", "x >= y"
"x = y", "x != y"
"x & y"
"x y"
"x && y"
"x y"
"x ? y : z"
"x.y"
"x = y", "x += y", "x -= y"

5.10 Variables, syntax elements, and tables

Syntax elements in the bitstream are represented in **bold** type. Each syntax element is described by its name (all lower case letters with underscore characters), and one descriptor for its method of coded representation. The decoding process behaves according to the value of the syntax element and to the values of previously decoded syntax elements. When a value of a syntax element is used in the syntax tables or the text, it appears in regular (i.e. not bold) type.

In some cases, the syntax tables may use the values of other variables derived from syntax elements values. Such variables appear in the syntax tables, or text, named by a mixture of lower case and upper case letters and without any underscore characters. Variables starting with an upper case letter are derived for the decoding of the current syntax structure and all depending syntax structures. Variables starting with an upper case letter may be used in the decoding process for later syntax structures without mentioning the originating syntax structure of the variable. Variables starting with a lower case letter are only used within the clause in which they are derived.

In some cases, "mnemonic" names for syntax element values or variable values are used interchangeably with their numerical values. Sometimes "mnemonic" names are used without any associated numerical values. The association of values and names is specified in the text. The names are constructed from one or more groups of letters separated by an underscore character. Each group starts with an upper case letter and may contain more upper case letters.

NOTE The syntax is described in a manner that closely follows the C-language syntactic constructs.

Functions that specify properties of the current position in the bitstream are referred to as syntax functions. These functions are specified in 7.2 and assume the existence of a bitstream pointer with an indication of the position of the next bit to be read by the decoding process from the bitstream. Syntax functions are described by their names, which are constructed as syntax element names and end with left and right round parentheses including zero or more variable names (for definition) or values (for usage), separated by commas (if more than one variable).

Functions that are not syntax functions (including mathematical functions specified in 5.8) are described by their names, which start with an upper case letter, contain a mixture of lower and upper case letters without any underscore character, and end with left and right parentheses including zero or more variable names (for definition) or values (for usage) separated by commas (if more than one variable).

A one-dimensional array is referred to as a list. A two-dimensional array is referred to as a matrix. Arrays can either be syntax elements or variables. Subscripts or square parentheses are used for the indexing of arrays. In reference to a visual depiction of a matrix, the first subscript is used as a row

(vertical) index and the second subscript is used as a column (horizontal) index. The indexing order is reversed when using square parentheses rather than subscripts for indexing. Thus, an element of a matrix s at horizontal position x and vertical position y may be denoted either as $s[x][y]$ or as s_{yx} . A single column of a matrix may be referred to as a list and denoted by omission of the row index. Thus, the column of a matrix s at horizontal position x may be referred to as the list $s[x]$.

A specification of values of the entries in rows and columns of an array may be denoted by $\{ \{ \dots \} \{ \dots \} \}$, where each inner pair of brackets specifies the values of the elements within a row in increasing column order and the rows are ordered in increasing row order. Thus, setting a matrix s equal to $\{ \{ 1 6 \} \{ 4 9 \} \}$ specifies that $s[0][0]$ is set equal to 1, $s[1][0]$ is set equal to 6, $s[0][1]$ is set equal to 4, and $s[1][1]$ is set equal to 9.

Binary notation is indicated by enclosing the string of bit values by single quote marks. For example, '01000001' represents an eight-bit string having only its second and its last bits (counted from the most to the least significant bit) equal to 1.

Hexadecimal notation, indicated by prefixing the hexadecimal number by "0x", may be used instead of binary notation when the number of bits is an integer multiple of 4. For example, 0x41 represents an eight-bit string having only its second and its last bits (counted from the most to the least significant bit) equal to 1.

Numerical values not enclosed in single quotes and not prefixed by "0x" are decimal values.

A value equal to 0 represents a FALSE condition in a test statement. The value TRUE is represented by any value different from zero.

5.11 Text description of logical operations

In the text, a statement of logical operations as would be described mathematically in the following form:

```
if( condition 0 )
    statement 0
else if( condition 1 )
    statement 1
...
else /* informative remark on remaining condition */
    statement n
```

may be described in the following manner:

```
... as follows / ... the following applies
- If condition 0, statement 0
- Otherwise, if condition 1, statement 1
- ...
- Otherwise (informative remark on remaining condition), statement n
```

Each "If ... Otherwise, if ... Otherwise, ..." statement in the text is introduced with "... as follows" or "... the following applies" immediately followed by "If ...". The last condition of the "If ... Otherwise, if ... Otherwise, ..." is always an "Otherwise, ...". Interleaved "If ... Otherwise, if ... Otherwise, ..." statements can be identified by matching "... as follows" or "... the following applies" with the ending "Otherwise, ...".

In the text, a statement of logical operations as would be described mathematically in the following form:

```
if( condition 0a && condition 0b )
    statement 0
else if( condition 1a || condition 1b )
    statement 1
...
else
    statement n
```

may be described in the following manner:

ISO/IEC 23008-2:2017(E)

... as follows / ... the following applies

- If all of the following conditions are true, statement 0:
 - condition 0a
 - condition 0b
- Otherwise, if one or more of the following conditions are true, statement 1:
 - condition 1a
 - condition 1b
- ...
- Otherwise, statement n

In the text, a statement of logical operations as would be described mathematically in the following form:

```
if( condition 0)
    statement 0
if( condition 1)
    statement 1
```

may be described in the following manner:

When condition 0, statement 0

When condition 1, statement 1

5.12 Processes

Processes are used to describe the decoding of syntax elements. A process has a separate specification and invoking. All syntax elements and upper case variables that pertain to the current syntax structure and depending syntax structures are available in the process specification and invoking. A process specification may also have a lower case variable explicitly specified as input. Each process specification has explicitly specified an output. The output is a variable that can either be an upper case variable or a lower case variable.

When invoking a process, the assignment of variables is specified as follows:

- If the variables at the invoking and the process specification do not have the same name, the variables are explicitly assigned to lower case input or output variables of the process specification.
- Otherwise (the variables at the invoking and the process specification have the same name), assignment is implied.

In the specification of a process, a specific coding block may be referred to by the variable name having a value equal to the address of the specific coding block.

6 Bitstream and picture formats, partitionings, scanning processes, and neighbouring relationships

6.1 Bitstream formats

This clause specifies the relationship between the NAL unit stream and byte stream, either of which are referred to as the bitstream.

The bitstream can be in one of two formats: the NAL unit stream format or the byte stream format. The NAL unit stream format is conceptually the more “basic” type. It consists of a sequence of syntax structures called NAL units. This sequence is ordered in decoding order. There are constraints imposed on the decoding order (and contents) of the NAL units in the NAL unit stream.

The byte stream format can be constructed from the NAL unit stream format by ordering the NAL units in decoding order and prefixing each NAL unit with a start code prefix and zero or more zero-valued bytes to form a stream of bytes. The NAL unit stream format can be extracted from the byte stream format by searching for the location of the unique start code prefix pattern within this stream of bytes.

Methods of framing the NAL units in a manner other than the use of the byte stream format are outside the scope of this document. The byte stream format is specified in Annex B.

6.2 Source, decoded, and output picture formats

This subclause specifies the relationship between source and decoded pictures that is given via the bitstream.

The video source that is represented by the bitstream is a sequence of pictures in decoding order.

The source and decoded pictures are each comprised of one or more sample arrays:

- Luma (Y) only (monochrome);
- Luma and two chroma (YCbCr or YCgCo);
- Green, Blue and Red (GBR, also known as RGB);
- Arrays representing other unspecified monochrome or tri-stimulus colour samplings (for example, YZX, also known as XYZ);

For convenience of notation and terminology in this document, the variables and terms associated with these arrays are referred to as luma (or L or Y) and chroma, where the two chroma arrays are referred to as Cb and Cr, regardless of the actual colour representation method in use. The actual colour representation method in use can be indicated in syntax that is specified in Annex E.

The variables SubWidthC, and SubHeightC are specified in Table 6-1, depending on the chroma format sampling structure, which is specified through chroma_format_idc and separate_colour_plane_flag. Other values of chroma_format_idc, SubWidthC, and SubHeightC may be specified in the future by ITU-T | ISO/IEC.

Table 6-1 — SubWidthC, and SubHeightC values derived from chroma_format_idc and separate_colour_plane_flag

chroma_format_idc	separate_colour_plane_flag	Chroma format	SubWidthC	SubHeightC
0	0	monochrome	1	1
1	0	4:2:0	2	2
2	0	4:2:2	2	1
3	0	4:4:4	1	1
3	1	4:4:4	1	1

In monochrome sampling, there is only one sample array, which is nominally considered the luma array.

In 4:2:0 sampling, each of the two chroma arrays has half the height and half the width of the luma array.

In 4:2:2 sampling, each of the two chroma arrays has the same height and half the width of the luma array.

In 4:4:4 sampling, depending on the value of separate_colour_plane_flag, the following apply:

- If separate_colour_plane_flag is equal to 0, each of the two chroma arrays has the same height and width as the luma array.
- Otherwise (separate_colour_plane_flag is equal to 1), the three colour planes are separately processed as monochrome sampled pictures.

ISO/IEC 23008-2:2017(E)

The number of bits necessary for the representation of each of the samples in the luma and chroma arrays in a video sequence is in the range of 8 to 16, inclusive, and the number of bits used in the luma array may differ from the number of bits used in the chroma arrays.

When the value of chroma_format_idc is equal to 1, the nominal vertical and horizontal relative locations of luma and chroma samples in pictures are shown in Figure 6-1. Alternative chroma sample relative locations may be indicated in video usability information (see Annex E).

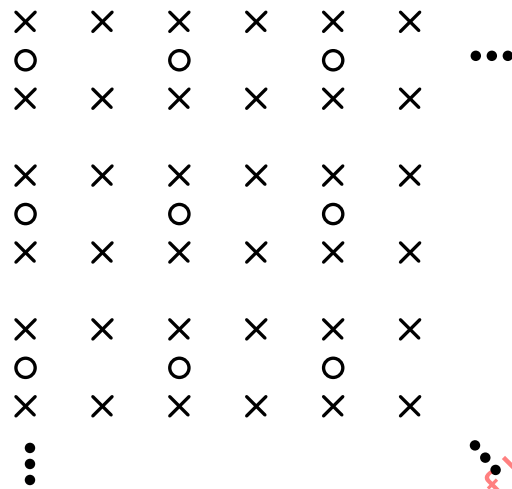

Guide:

- X = Location of luma sample
- O = Location of chroma sample

Figure 6-1 — Nominal vertical and horizontal locations of 4:2:0 luma and chroma samples in a picture

When the value of chroma_format_idc is equal to 2, the chroma samples are co-sited with the corresponding luma samples and the nominal locations in a picture are as shown in Figure 6-2.

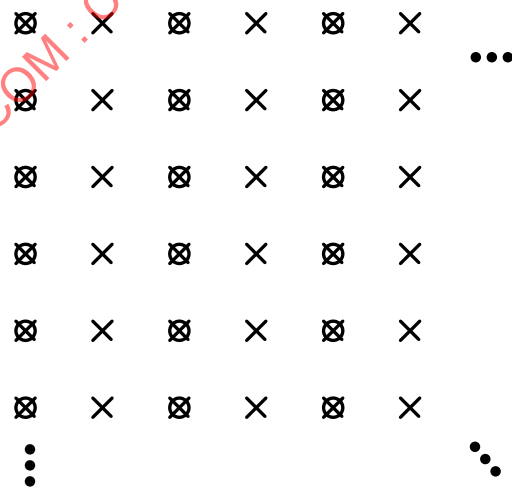

Guide:

- X = Location of luma sample
- ◻ = Location of chroma sample

Figure 6-2 — Nominal vertical and horizontal locations of 4:2:2 luma and chroma samples in a picture

When the value of `chroma_format_idc` is equal to 3, all array samples are co-sited for all cases of pictures and the nominal locations in a picture are as shown in Figure 6-3.

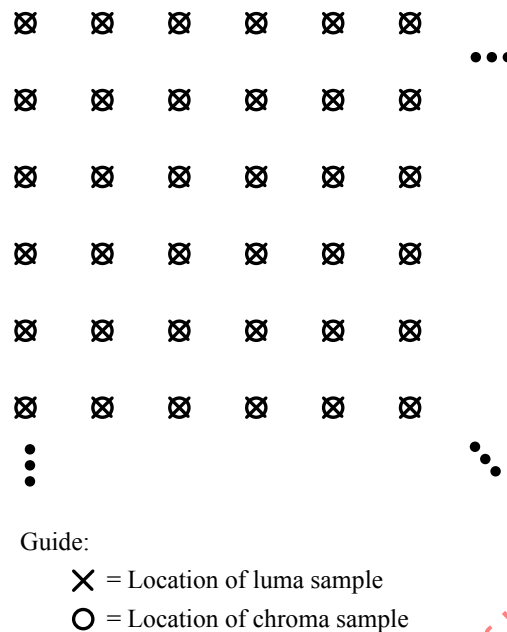

Figure 6-3 — Nominal vertical and horizontal locations of 4:4:4 luma and chroma samples in a picture

6.3 Partitioning of pictures, slices, slice segments, tiles, coding tree units, and coding tree blocks

6.3.1 Partitioning of pictures into slices, slice segments, and tiles

This subclause specifies how a picture is partitioned into slices, slice segments, and tiles. Pictures are divided into slices and tiles. A slice is a sequence of one or more slice segments starting with an independent slice segment and containing all subsequent dependent slice segments (if any) that precede the next independent slice segment (if any) within the same picture. A slice segment is a sequence of coding tree units. Likewise, a tile is a sequence of coding tree units.

For example, a picture may be divided into two slices as shown in Figure 6-4. In this example, the first slice is composed of an independent slice segment containing 4 coding tree units, a dependent slice segment containing 32 coding tree units, and another dependent slice segment containing 24 coding tree units; and the second slice consists of a single independent slice segment containing the remaining 39 coding tree units of the picture.

As another example, a picture may be divided into two tiles separated by a vertical tile boundary as shown in Figure 6-5. The left side of the figure illustrates a case in which the picture only contains one slice, starting with an independent slice segment and followed by four dependent slice segments. The right side of the figure illustrates an alternative case in which the picture contains two slices in the first tile and one slice in the second tile.

Unlike slices, tiles are always rectangular. A tile always contains an integer number of coding tree units, and may consist of coding tree units contained in more than one slice. Similarly, a slice may consist of coding tree units contained in more than one tile.

One or both of the following conditions shall be fulfilled for each slice and tile:

- All coding tree units in a slice belong to the same tile.
- All coding tree units in a tile belong to the same slice.

ISO/IEC 23008-2:2017(E)

NOTE 1 Within the same picture, there may be both slices that contain multiple tiles and tiles that contain multiple slices.

One or both of the following conditions shall be fulfilled for each slice segment and tile:

- All coding tree units in a slice segment belong to the same tile.
- All coding tree units in a tile belong to the same slice segment.

When a picture is coded using three separate colour planes (separate_colour_plane_flag is equal to 1), a slice contains only coding tree blocks of one colour component being identified by the corresponding value of colour_plane_id, and each colour component array of a picture consists of slices having the same colour_plane_id value. Coded slices with different values of colour_plane_id within a picture may be interleaved with each other under the constraint that for each value of colour_plane_id, the coded slice segment NAL units with that value of colour_plane_id shall be in the order of increasing coding tree block address in tile scan order for the first coding tree block of each coded slice segment NAL unit.

NOTE 2 When separate_colour_plane_flag is equal to 0, each coding tree block of a picture is contained in exactly one slice. When separate_colour_plane_flag is equal to 1, each coding tree block of a colour component is contained in exactly one slice (i.e. information for each coding tree block of a picture is present in exactly three slices and these three slices have different values of colour_plane_id).

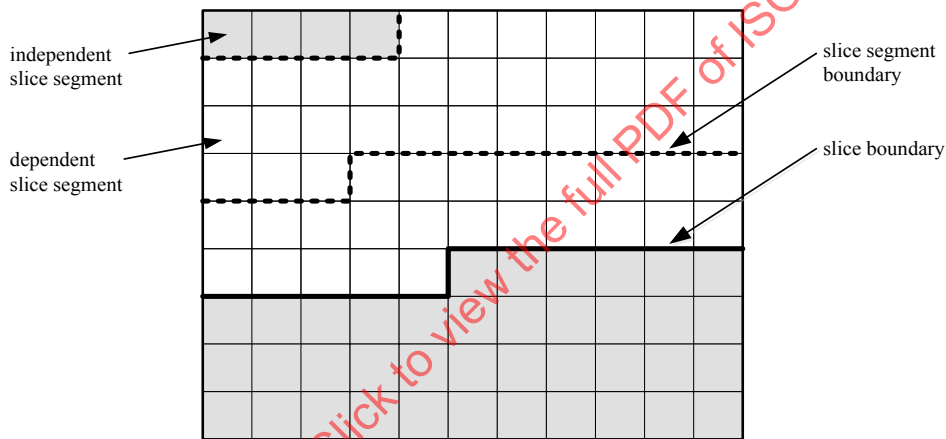

Figure 6-4 — A picture with 11 by 9 luma coding tree blocks that is partitioned into two slices, the first of which is partitioned into three slice segments (informative)

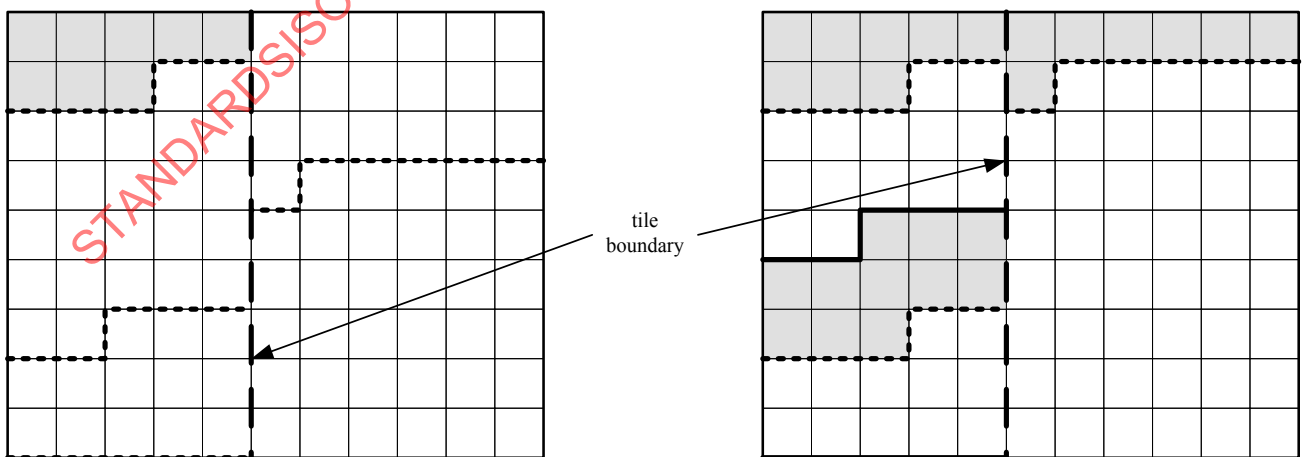

Figure 6-5 — A picture with 11 by 9 luma coding tree blocks that is partitioned into two tiles and one slice (left) or is partitioned into two tiles and three slices (right) (informative)

6.3.2 Block and quadtree structures

The samples are processed in units of coding tree blocks. The array size for each luma coding tree block in both width and height is $CtbSizeY$ in units of samples. The width and height of the array for each chroma coding tree block are $CtbWidthC$ and $CtbHeightC$, respectively, in units of samples.

Each coding tree block is assigned a partition signalling to identify the block sizes for intra or inter prediction and for transform coding. The partitioning is a recursive quadtree partitioning. The root of the quadtree is associated with the coding tree block. The quadtree is split until a leaf is reached, which is referred to as the coding block. When the component width is not an integer number of the coding tree block size, the coding tree blocks at the right component boundary are incomplete. When the component height is not an integer multiple of the coding tree block size, the coding tree blocks at the bottom component boundary are incomplete.

The coding block is the root node of two trees, the prediction tree and the transform tree. The prediction tree specifies the position and size of prediction blocks. The transform tree specifies the position and size of transform blocks. The splitting information for luma and chroma is identical for the prediction tree and may or may not be identical for the transform tree.

The blocks and associated syntax structures are grouped into “unit” structures as follows:

- One prediction block (monochrome picture or `separate_colour_plane_flag` is equal to 1) or three prediction blocks (luma and chroma components of a picture in 4:2:0 or 4:4:4 colour format) or five prediction blocks (luma and chroma components of a picture in 4:2:2 colour format) and the associated prediction syntax structures units are associated with a prediction unit.
- One transform block (monochrome picture or `separate_colour_plane_flag` is equal to 1) or three transform blocks (luma and chroma components of a picture in 4:2:0 or 4:4:4 colour format) or five transform blocks (luma and chroma components of a picture in 4:2:2 colour format) and the associated transform syntax structures units are associated with a transform unit.
- One coding block (monochrome picture or `separate_colour_plane_flag` is equal to 1) or three coding blocks (luma and chroma), the associated coding syntax structures and the associated prediction and transform units are associated with a coding unit.
- One coding tree block (monochrome picture or `separate_colour_plane_flag` is equal to 1) or three coding tree blocks (luma and chroma), the associated coding tree syntax structures and the associated coding units are associated with a coding tree unit.

6.3.3 Spatial or component-wise partitionings

The following divisions of processing elements of this document form spatial or component-wise partitionings:

- The division of each picture into components
- The division of each component into coding tree blocks
- The division of each picture into tile columns
- The division of each picture into tile rows
- The division of each tile column into tiles
- The division of each tile row into tiles
- The division of each tile into coding tree units
- The division of each picture into slices

ISO/IEC 23008-2:2017(E)

- The division of each slice into slice segments
- The division of each slice segment into coding tree units
- The division of each coding tree unit into coding tree blocks
- The division of each coding tree block into coding blocks, except that the coding tree blocks are incomplete at the right component boundary when the component width is not an integer multiple of the coding tree block size and the coding tree blocks are incomplete at the bottom component boundary when the component height is not an integer multiple of the coding tree block size
- The division of each coding tree unit into coding units, except that the coding tree units are incomplete at the right picture boundary when the picture width in luma samples is not an integer multiple of the luma coding tree block size and the coding tree units are incomplete at the bottom picture boundary when the picture height in luma samples is not an integer multiple of the luma coding tree block size
- The division of each coding unit into prediction units
- The division of each coding unit into transform units
- The division of each coding unit into coding blocks
- The division of each coding block into prediction blocks
- The division of each coding block into transform blocks
- The division of each prediction unit into prediction blocks
- The division of each transform unit into transform blocks.

6.4 Availability processes

6.4.1 Derivation process for z-scan order block availability

Inputs to this process are

- the luma location (x_{Curr} , y_{Curr}) of the top-left sample of the current block relative to the top-left luma sample of the current picture, and
- the luma location (x_{NbY} , y_{NbY}) covered by a neighbouring block relative to the top-left luma sample of the current picture.

Output of this process is the availability of the neighbouring block covering the location (x_{NbY} , y_{NbY}), denoted as $availableN$.

The minimum luma block address in z-scan order $minBlockAddrCurr$ of the current block is derived as follows:

$$minBlockAddrCurr = MinTbAddrZs[xCurr \gg MinTbLog2SizeY][yCurr \gg MinTbLog2SizeY] \quad (6-1)$$

The minimum luma block address in z-scan order $minBlockAddrN$ of the neighbouring block covering the location (x_{NbY} , y_{NbY}) is derived as follows.

- If one or more of the following conditions are true, $minBlockAddrN$ is set equal to -1 :
 - x_{NbY} is less than 0;
 - y_{NbY} is less than 0;

- $xNbY$ is greater than or equal to $pic_width_in_luma_samples$;
- $yNbY$ is greater than or equal to $pic_height_in_luma_samples$.
- Otherwise ($xNbY$ and $yNbY$ are inside the picture boundaries),

$$minBlockAddrN = MinTbAddrZs[xNbY \gg MinTbLog2SizeY][yNbY \gg MinTbLog2SizeY] \quad (6-2)$$

The neighbouring block availability $availableN$ is derived as follows.

- If one or more of the following conditions are true, $availableN$ is set equal to FALSE:
 - $minBlockAddrN$ is less than 0;
 - $minBlockAddrN$ is greater than $minBlockAddrCurr$;
 - the variable $SliceAddrRs$ associated with the slice segment containing the neighbouring block with the minimum luma block address $minBlockAddrN$ differs in value from the variable $SliceAddrRs$ associated with the slice segment containing the current block with the minimum luma block address $minBlockAddrCurr$;
 - the neighbouring block with the minimum luma block address $minBlockAddrN$ is contained in a different tile than the current block with the minimum luma block address $minBlockAddrCurr$.
- Otherwise, $availableN$ is set equal to TRUE.

6.4.2 Derivation process for prediction block availability

Inputs to this process are

- the luma location (xCb, yCb) of the top-left sample of the current luma coding block relative to the top-left luma sample of the current picture,
- a variable $nCbS$ specifying the size of the current luma coding block,
- the luma location (xPb, yPb) of the top-left sample of the current luma prediction block relative to the top-left luma sample of the current picture,
- two variables $nPbW$ and $nPbH$ specifying the width and the height of the current luma prediction block,
- a variable $partIdx$ specifying the partition index of the current prediction unit within the current coding unit, and
- the luma location ($xNbY, yNbY$) covered by a neighbouring prediction block relative to the top-left luma sample of the current picture.

Output of this process is the availability of the neighbouring prediction block covering the location ($xNbY, yNbY$), denoted as $availableN$ is derived as follows.

The variable $sameCb$ identifies whether the current luma prediction block and the neighbouring luma prediction block cover the same luma coding block, and is derived as follows:

- If all of the following conditions are true, $sameCb$ is set equal to TRUE:
 - xCb is less than or equal than $xNbY$;
 - yCb is less than or equal than $yNbY$;

ISO/IEC 23008-2:2017(E)

- $(x_{Cb} + n_{CbS})$ is greater than x_{NbY} ;
- $(y_{Cb} + n_{CbS})$ is greater than y_{NbY} .
- Otherwise, `sameCb` is set equal to `FALSE`.

The neighbouring prediction block availability `availableN` is derived as follows.

- If `sameCb` is equal to `FALSE`, the derivation process for z-scan order block availability as specified in 6.4.1 is invoked with (x_{Curr}, y_{Curr}) set equal to (x_{Pb}, y_{Pb}) and the luma location (x_{NbY}, y_{NbY}) as inputs, and the output is assigned to `availableN`.
- Otherwise, if all of the following conditions are true, `availableN` is set equal to `FALSE`:
 - $(n_{PbW} \ll 1)$ is equal to n_{CbS} ;
 - $(n_{PbH} \ll 1)$ is equal to n_{CbS} ;
 - `partIdx` is equal to 1;
 - $(y_{Cb} + n_{PbH})$ is less than or equal to y_{NbY} ;
 - $(x_{Cb} + n_{PbW})$ is greater than x_{NbY} .
- Otherwise, `availableN` is set equal to `TRUE`.

When `availableN` is equal to `TRUE` and `CuPredMode` $[x_{NbY}][y_{NbY}]$ is equal to `MODE_INTRA`, `availableN` is set equal to `FALSE`.

6.5 Scanning processes

6.5.1 Coding tree block raster and tile scanning conversion process

The list `colWidth` $[i]$ for i ranging from 0 to `num_tile_columns_minus1`, inclusive, specifying the width of the i -th tile column in units of CTBs, is derived as follows:

```
if( uniform_spacing_flag )
    for( i = 0; i <= num_tile_columns_minus1; i++ )
        colWidth[ i ] = (( i + 1 ) * PicWidthInCtbsY ) / ( num_tile_columns_minus1 + 1 ) -
            ( i * PicWidthInCtbsY ) / ( num_tile_columns_minus1 + 1 )
else {
    colWidth[ num_tile_columns_minus1 ] = PicWidthInCtbsY
    for( i = 0; i < num_tile_columns_minus1; i++ ) {
        colWidth[ i ] = column_width_minus1[ i ] + 1
        colWidth[ num_tile_columns_minus1 ] -= colWidth[ i ]
    }
}
```

(6-3)

The list `rowHeight` $[j]$ for j ranging from 0 to `num_tile_rows_minus1`, inclusive, specifying the height of the j -th tile row in units of CTBs, is derived as follows:

```

if( uniform_spacing_flag )
  for( j = 0; j <= num_tile_rows_minus1; j++ )
    rowHeight[ j ] = ( ( j + 1 ) * PicHeightInCtbsY ) / ( num_tile_rows_minus1 + 1 ) -
      ( j * PicHeightInCtbsY ) / ( num_tile_rows_minus1 + 1 )
else {
  rowHeight[ num_tile_rows_minus1 ] = PicHeightInCtbsY
  for( j = 0; j < num_tile_rows_minus1; j++ ) {
    rowHeight[ j ] = row_height_minus1[ j ] + 1
    rowHeight[ num_tile_rows_minus1 ] -= rowHeight[ j ]
  }
}

```

(6-4)

The list `colBd[i]` for `i` ranging from 0 to `num_tile_columns_minus1 + 1`, inclusive, specifying the location of the `i`-th tile column boundary in units of coding tree blocks, is derived as follows:

```

for( colBd[ 0 ] = 0, i = 0; i <= num_tile_columns_minus1; i++ )
  colBd[ i + 1 ] = colBd[ i ] + colWidth[ i ]

```

(6-5)

The list `rowBd[j]` for `j` ranging from 0 to `num_tile_rows_minus1 + 1`, inclusive, specifying the location of the `j`-th tile row boundary in units of coding tree blocks, is derived as follows:

```

for( rowBd[ 0 ] = 0, j = 0; j <= num_tile_rows_minus1; j++ )
  rowBd[ j + 1 ] = rowBd[ j ] + rowHeight[ j ]

```

(6-6)

The list `CtbAddrRsToTs[ctbAddrRs]` for `ctbAddrRs` ranging from 0 to `PicSizeInCtbsY - 1`, inclusive, specifying the conversion from a CTB address in CTB raster scan of a picture to a CTB address in tile scan, is derived as follows:

```

for( ctbAddrRs = 0; ctbAddrRs < PicSizeInCtbsY; ctbAddrRs++ ) {
  tbX = ctbAddrRs % PicWidthInCtbsY
  tbY = ctbAddrRs / PicWidthInCtbsY
  for( i = 0; i <= num_tile_columns_minus1; i++ )
    if( tbX >= colBd[ i ] )
      tileX = i
  for( j = 0; j <= num_tile_rows_minus1; j++ )
    if( tbY >= rowBd[ j ] )
      tileY = j
  CtbAddrRsToTs[ ctbAddrRs ] = 0
  for( i = 0; i < tileX; i++ )
    CtbAddrRsToTs[ ctbAddrRs ] += rowHeight[ tileY ] * colWidth[ i ]
  for( j = 0; j < tileY; j++ )
    CtbAddrRsToTs[ ctbAddrRs ] += PicWidthInCtbsY * rowHeight[ j ]
  CtbAddrRsToTs[ ctbAddrRs ] += ( tbY - rowBd[ tileY ] ) * colWidth[ tileX ] + tbX - colBd[ tileX ]
}

```

(6-7)

The list `CtbAddrTsToRs[ctbAddrTs]` for `ctbAddrTs` ranging from 0 to `PicSizeInCtbsY - 1`, inclusive, specifying the conversion from a CTB address in tile scan to a CTB address in CTB raster scan of a picture, is derived as follows:

```

for( ctbAddrRs = 0; ctbAddrRs < PicSizeInCtbsY; ctbAddrRs++ )
  CtbAddrTsToRs[ CtbAddrRsToTs[ ctbAddrRs ] ] = ctbAddrRs

```

(6-8)

The list `TileId[ctbAddrTs]` for `ctbAddrTs` ranging from 0 to `PicSizeInCtbsY - 1`, inclusive, specifying the conversion from a CTB address in tile scan to a tile ID, is derived as follows:

```

for( j = 0, tileIdx = 0; j <= num_tile_rows_minus1; j++ )
  for( i = 0; i <= num_tile_columns_minus1; i++, tileIdx++ )
    for( y = rowBd[ j ]; y < rowBd[ j + 1 ]; y++ )
      for( x = colBd[ i ]; x < colBd[ i + 1 ]; x++ )
        TileId[ CtbAddrRsToTs[ y * PicWidthInCtbsY + x ] ] = tileIdx

```

(6-9)

ISO/IEC 23008-2:2017(E)

The values of `ColumnWidthInLumaSamples[i]`, specifying the width of the *i*-th tile column in units of luma samples, are set equal to `colWidth[i] << CtbLog2SizeY` for *i* ranging from 0 to `num_tile_columns_minus1`, inclusive.

The values of `RowHeightInLumaSamples[j]`, specifying the height of the *j*-th tile row in units of luma samples, are set equal to `rowHeight[j] << CtbLog2SizeY` for *j* ranging from 0 to `num_tile_rows_minus1`, inclusive.

6.5.2 Z-scan order array initialization process

The array `MinTbAddrZs` with elements `MinTbAddrZs[x][y]` for *x* ranging from 0 to $(\text{PicWidthInCtbsY} \ll (\text{CtbLog2SizeY} - \text{MinTbLog2SizeY})) - 1$, inclusive, and *y* ranging from 0 to $(\text{PicHeightInCtbsY} \ll (\text{CtbLog2SizeY} - \text{MinTbLog2SizeY})) - 1$, specifying the conversion from a location (*x*, *y*) in units of minimum blocks to a minimum block address in z-scan order, inclusive, is derived as follows:

```
for( y = 0; y < ( PicHeightInCtbsY << ( CtbLog2SizeY - MinTbLog2SizeY ) ); y++ )
  for( x = 0; x < ( PicWidthInCtbsY << ( CtbLog2SizeY - MinTbLog2SizeY ) ); x++ ) {
    tbX = ( x << MinTbLog2SizeY ) >> CtbLog2SizeY
    tbY = ( y << MinTbLog2SizeY ) >> CtbLog2SizeY
    ctbAddrRs = PicWidthInCtbsY * tbY + tbX
    MinTbAddrZs[ x ][ y ] = CtbAddrRsToTs[ ctbAddrRs ] <<
      ( ( CtbLog2SizeY - MinTbLog2SizeY ) * 2 )
    for( i = 0, p = 0; i < ( CtbLog2SizeY - MinTbLog2SizeY ); i++ ) {
      m = 1 << i
      p += ( m & x ? m * m : 0 ) + ( m & y ? 2 * m * m : 0 )
    }
    MinTbAddrZs[ x ][ y ] += p
  }
}
```

(6-10)

6.5.3 Up-right diagonal scan order array initialization process

Input to this process is a block size `blkSize`.

Output of this process is the array `diagScan[sPos][sComp]`. The array index `sPos` specify the scan position ranging from 0 to $(\text{blkSize} * \text{blkSize}) - 1$. The array index `sComp` equal to 0 specifies the horizontal component and the array index `sComp` equal to 1 specifies the vertical component. Depending on the value of `blkSize`, the array `diagScan` is derived as follows:

```
i = 0
x = 0
y = 0
stopLoop = FALSE
while( !stopLoop ) {
  while( y >= 0 ) {
    if( x < blkSize && y < blkSize ) {
      diagScan[ i ][ 0 ] = x
      diagScan[ i ][ 1 ] = y
      i++
    }
    y--
    x++
  }
  y
  x
  if( i >= blkSize * blkSize )
    stopLoop = TRUE
}
```

(6-11)

6.5.4 Horizontal scan order array initialization process

Input to this process is a block size blkSize.

Output of this process is the array horScan[sPos][sComp]. The array index sPos specifies the scan position ranging from 0 to (blkSize * blkSize) - 1. The array index sComp equal to 0 specifies the horizontal component and the array index sComp equal to 1 specifies the vertical component. Depending on the value of blkSize, the array horScan is derived as follows:

```

i = 0
for( y = 0; y < blkSize; y++ )
  for( x = 0; x < blkSize; x++ ) {
    horScan[ i ][ 0 ] = x
    horScan[ i ][ 1 ] = y
    i++
  }

```

(6-12)

6.5.5 Vertical scan order array initialization process

Input to this process is a block size blkSize.

Output of this process is the array verScan[sPos][sComp]. The array index sPos specifies the scan position ranging from 0 to (blkSize * blkSize) - 1. The array index sComp equal to 0 specifies the horizontal component and the array index sComp equal to 1 specifies the vertical component. Depending on the value of blkSize, the array verScan is derived as follows:

```

i = 0
for( x = 0; x < blkSize; x++ )
  for( y = 0; y < blkSize; y++ ) {
    verScan[ i ][ 0 ] = x
    verScan[ i ][ 1 ] = y
    i++
  }

```

(6-13)

6.5.6 Traverse scan order array initialization process

Input to this process is a block size blkSize.

Output of this process is the array travScan[sPos][sComp]. The array index sPos specifies the scan position ranging from 0 to (blkSize * blkSize) - 1, inclusive. The array index sComp equal to 0 specifies the horizontal component and the array index sComp equal to 1 specifies the vertical component. Depending on the value of blkSize, the array travScan is derived as follows:

```

i = 0
for( y = 0; y < blkSize; y++ )
  if( y % 2 == 0 )
    for( x = 0; x < blkSize; x++ ) {
      travScan[ i ][ 0 ] = x
      travScan[ i ][ 1 ] = y
      i++
    }
  else
    for( x = blkSize - 1; x >= 0; x-- ) {
      travScan[ i ][ 0 ] = x
      travScan[ i ][ 1 ] = y
      i++
    }

```

(6-14)

7 Syntax and semantics

7.1 Method of specifying syntax in tabular form

The syntax tables specify a superset of the syntax of all allowed bitstreams. Additional constraints on the syntax may be specified, either directly or indirectly, in other clauses.

NOTE An actual decoder is expected to implement some means for identifying entry points into the bitstream and some means to identify and handle non-conforming bitstreams. The methods for identifying and handling errors and other such situations are not specified in this document.

The following table lists examples of the syntax specification format. When **syntax_element** appears, it specifies that a syntax element is parsed from the bitstream and the bitstream pointer is advanced to the next position beyond the syntax element in the bitstream parsing process.

	Descriptor
/* A statement can be a syntax element with an associated descriptor or can be an expression used to specify conditions for the existence, type, and quantity of syntax elements, as in the following two examples */	
syntax_element	ue(v)
conditioning statement	
/* A group of statements enclosed in curly brackets is a compound statement and is treated functionally as a single statement. */	
{	
statement	
statement	
...	
}	
/* A "while" structure specifies a test of whether a condition is true, and if true, specifies evaluation of a statement (or compound statement) repeatedly until the condition is no longer true */	
while(condition)	
statement	
/* A "do ... while" structure specifies evaluation of a statement once, followed by a test of whether a condition is true, and if true, specifies repeated evaluation of the statement until the condition is no longer true */	
do	
statement	
while(condition)	
/* An "if ... else" structure specifies a test of whether a condition is true and, if the condition is true, specifies evaluation of a primary statement, otherwise, specifies evaluation of an alternative statement. The "else" part of the structure and the associated alternative statement is omitted if no alternative statement evaluation is needed */	
if(condition)	
primary statement	
else	
alternative statement	

/* A "for" structure specifies evaluation of an initial statement, followed by a test of a condition, and if the condition is true, specifies repeated evaluation of a primary statement followed by a subsequent statement until the condition is no longer true. */	
for(initial statement; condition; subsequent statement)	
primary statement	

7.2 Specification of syntax functions and descriptors

The functions presented here are used in the syntactical description. These functions are expressed in terms of the value of a bitstream pointer that indicates the position of the next bit to be read by the decoding process from the bitstream.

byte_aligned() is specified as follows:

- If the current position in the bitstream is on a byte boundary, i.e. the next bit in the bitstream is the first bit in a byte, the return value of byte_aligned() is equal to TRUE.
- Otherwise, the return value of byte_aligned() is equal to FALSE.

more_data_in_byte_stream(), which is used only in the byte stream NAL unit syntax structure specified in Annex B, is specified as follows:

- If more data follow in the byte stream, the return value of more_data_in_byte_stream() is equal to TRUE.
- Otherwise, the return value of more_data_in_byte_stream() is equal to FALSE.

more_data_in_payload() is specified as follows:

- If byte_aligned() is equal to TRUE and the current position in the sei_payload() syntax structure is $8 * \text{payloadSize}$ bits from the beginning of the sei_payload() syntax structure, the return value of more_data_in_payload() is equal to FALSE.
- Otherwise, the return value of more_data_in_payload() is equal to TRUE.

more_rbsp_data() is specified as follows:

- If there is no more data in the RBSP, the return value of more_rbsp_data() is equal to FALSE.
- Otherwise, the RBSP data are searched for the last (least significant, right-most) bit equal to 1 that is present in the RBSP. Given the position of this bit, which is the first bit (rbsp_stop_one_bit) of the rbsp_trailing_bits() syntax structure, the following apply:
 - If there is more data in an RBSP before the rbsp_trailing_bits() syntax structure, the return value of more_rbsp_data() is equal to TRUE.
 - Otherwise, the return value of more_rbsp_data() is equal to FALSE.

The method for enabling determination of whether there is more data in the RBSP is specified by the application (or in Annex B for applications that use the byte stream format).

more_rbsp_trailing_data() is specified as follows:

- If there is more data in an RBSP, the return value of more_rbsp_trailing_data() is equal to TRUE.
- Otherwise, the return value of more_rbsp_trailing_data() is equal to FALSE.

ISO/IEC 23008-2:2017(E)

`next_bits(n)` provides the next bits in the bitstream for comparison purposes, without advancing the bitstream pointer. It provides a look at the next n bits in the bitstream with n being its argument. When used within the byte stream format as specified in Annex B and fewer than n bits remain within the byte stream, `next_bits(n)` returns a value of 0.

`payload_extension_present()` is specified as follows:

- If the current position in the `sei_payload()` syntax structure is not the position of the last (least significant, right-most) bit that is equal to 1 that is less than $8 * \text{payloadSize}$ bits from the beginning of the syntax structure (i.e. the position of the `payload_bit_equal_to_one` syntax element), the return value of `payload_extension_present()` is equal to TRUE.
- Otherwise, the return value of `payload_extension_present()` is equal to FALSE.

`pic_layer_id(picX)` returns the value of the `nuh_layer_id` of the VCL NAL units in the picture `picX`.

`read_bits(n)` reads the next n bits from the bitstream and advances the bitstream pointer by n bit positions. When n is equal to 0, `read_bits(n)` is specified to return a value equal to 0 and to not advance the bitstream pointer.

The following descriptors specify the parsing process of each syntax element:

- `ae(v)`: context-adaptive arithmetic entropy-coded syntax element. The parsing process for this descriptor is specified in 9.3.
- `b(8)`: byte having any pattern of bit string (8 bits). The parsing process for this descriptor is specified by the return value of the function `read_bits(8)`.
- `f(n)`: fixed-pattern bit string using n bits written (from left to right) with the left bit first. The parsing process for this descriptor is specified by the return value of the function `read_bits(n)`.
- `i(n)`: signed integer using n bits. When n is “v” in the syntax table, the number of bits varies in a manner dependent on the value of other syntax elements. The parsing process for this descriptor is specified by the return value of the function `read_bits(n)` interpreted as a two's complement integer representation with most significant bit written first.
- `se(v)`: signed integer 0-th order Exp-Golomb-coded syntax element with the left bit first. The parsing process for this descriptor is specified in 9.2.
- `st(v)`: null-terminated string encoded as UTF-8 characters as specified in ISO/IEC 10646. The parsing process is specified as follows: `st(v)` begins at a byte-aligned position in the bitstream and reads and returns a series of bytes from the bitstream, beginning at the current position and continuing up to but not including the next byte-aligned byte that is equal to 0x00, and advances the bitstream pointer by $(\text{stringLength} + 1) * 8$ bit positions, where `stringLength` is equal to the number of bytes returned.

NOTE The `st(v)` syntax descriptor is only used in this document when the current position in the bitstream is a byte-aligned position.

- `u(n)`: unsigned integer using n bits. When n is “v” in the syntax table, the number of bits varies in a manner dependent on the value of other syntax elements. The parsing process for this descriptor is specified by the return value of the function `read_bits(n)` interpreted as a binary representation of an unsigned integer with most significant bit written first.
- `ue(v)`: unsigned integer 0-th order Exp-Golomb-coded syntax element with the left bit first. The parsing process for this descriptor is specified in 9.2.

7.3 Syntax in tabular form

7.3.1 NAL unit syntax

7.3.1.1 General NAL unit syntax

	Descriptor
nal_unit(NumBytesInNalUnit) {	
nal_unit_header()	
NumBytesInRbsp = 0	
for(i = 2; i < NumBytesInNalUnit; i++)	
if(i + 2 < NumBytesInNalUnit && next_bits(24) == 0x000003) {	
rbsp_byte [NumBytesInRbsp++]	b(8)
rbsp_byte [NumBytesInRbsp++]	b(8)
i += 2	
emulation_prevention_three_byte /* equal to 0x03 */	f(8)
} else	
rbsp_byte [NumBytesInRbsp++]	b(8)
}	

7.3.1.2 NAL unit header syntax

	Descriptor
nal_unit_header() {	
forbidden_zero_bit	f(1)
nal_unit_type	u(6)
nuh_layer_id	u(6)
nuh_temporal_id_plus1	u(3)
}	

7.3.2 Raw byte sequence payloads, trailing bits, and byte alignment syntax

7.3.2.1 Video parameter set RBSP syntax

	Descriptor
<code>video_parameter_set_rbsp() {</code>	
vps_video_parameter_set_id	u(4)
vps_base_layer_internal_flag	u(1)
vps_base_layer_available_flag	u(1)
vps_max_layers_minus1	u(6)
vps_max_sub_layers_minus1	u(3)
vps_temporal_id_nesting_flag	u(1)
vps_reserved_0xffff_16bits	u(16)
profile_tier_level(1, vps_max_sub_layers_minus1)	
vps_sub_layer_ordering_info_present_flag	u(1)
for(i = (vps_sub_layer_ordering_info_present_flag ? 0 : vps_max_sub_layers_minus1); i <= vps_max_sub_layers_minus1; i++) {	
vps_max_dec_pic_buffering_minus1[i]	ue(v)
vps_max_num_reorder_pics[i]	ue(v)
vps_max_latency_increase_plus1[i]	ue(v)
}	
vps_max_layer_id	u(6)
vps_num_layer_sets_minus1	ue(v)
for(i = 1; i <= vps_num_layer_sets_minus1; i++)	
for(j = 0; j <= vps_max_layer_id; j++)	
layer_id_included_flag[i][j]	u(1)
vps_timing_info_present_flag	u(1)
if(vps_timing_info_present_flag) {	
vps_num_units_in_tick	u(32)
vps_time_scale	u(32)
vps_poc_proportional_to_timing_flag	u(1)
if(vps_poc_proportional_to_timing_flag)	
vps_num_ticks_poc_diff_one_minus1	ue(v)
vps_num_hrd_parameters	ue(v)
for(i = 0; i < vps_num_hrd_parameters; i++) {	
hrd_layer_set_idx[i]	ue(v)
if(i > 0)	
cprms_present_flag[i]	u(1)
hrd_parameters(cprms_present_flag[i], vps_max_sub_layers_minus1)	
}	
}	
}	

vps_extension_flag	u(1)
if(vps_extension_flag)	
while(more_rbsp_data())	
vps_extension_data_flag	u(1)
rbsp_trailing_bits()	
}	

7.3.2.2 Sequence parameter set Rbsp syntax

7.3.2.2.1 General sequence parameter set Rbsp syntax

	Descriptor
seq_parameter_set_rbsp() {	
sps_video_parameter_set_id	u(4)
sps_max_sub_layers_minus1	u(3)
sps_temporal_id_nesting_flag	u(1)
profile_tier_level(1, sps_max_sub_layers_minus1)	
sps_seq_parameter_set_id	ue(v)
chroma_format_idc	ue(v)
if(chroma_format_idc == 3)	
separate_colour_plane_flag	u(1)
pic_width_in_luma_samples	ue(v)
pic_height_in_luma_samples	ue(v)
conformance_window_flag	u(1)
if(conformance_window_flag) {	
conf_win_left_offset	ue(v)
conf_win_right_offset	ue(v)
conf_win_top_offset	ue(v)
conf_win_bottom_offset	ue(v)
}	
bit_depth_luma_minus8	ue(v)
bit_depth_chroma_minus8	ue(v)
log2_max_pic_order_cnt_lsb_minus4	ue(v)
sps_sub_layer_ordering_info_present_flag	u(1)
for(i = (sps_sub_layer_ordering_info_present_flag ? 0 : sps_max_sub_layers_minus1); i <= sps_max_sub_layers_minus1; i++) {	
sps_max_dec_pic_buffering_minus1[i]	ue(v)
sps_max_num_reorder_pics[i]	ue(v)
sps_max_latency_increase_plus1[i]	ue(v)
}	
log2_min_luma_coding_block_size_minus3	ue(v)
log2_diff_max_min_luma_coding_block_size	ue(v)

log2_min_luma_transform_block_size_minus2	ue(v)
log2_diff_max_min_luma_transform_block_size	ue(v)
max_transform_hierarchy_depth_inter	ue(v)
max_transform_hierarchy_depth_intra	ue(v)
scaling_list_enabled_flag	u(1)
if(scaling_list_enabled_flag) {	
sps_scaling_list_data_present_flag	u(1)
if(sps_scaling_list_data_present_flag)	
scaling_list_data()	
}	
amp_enabled_flag	u(1)
sample_adaptive_offset_enabled_flag	u(1)
pcm_enabled_flag	u(1)
if(pcm_enabled_flag) {	
pcm_sample_bit_depth_luma_minus1	u(4)
pcm_sample_bit_depth_chroma_minus1	u(4)
log2_min_pcm_luma_coding_block_size_minus3	ue(v)
log2_diff_max_min_pcm_luma_coding_block_size	ue(v)
pcm_loop_filter_disabled_flag	u(1)
}	
num_short_term_ref_pic_sets	ue(v)
for(i = 0; i < num_short_term_ref_pic_sets; i++)	
st_ref_pic_set(i)	
long_term_ref_pics_present_flag	u(1)
if(long_term_ref_pics_present_flag) {	
num_long_term_ref_pics_sps	ue(v)
for(i = 0; i < num_long_term_ref_pics_sps; i++) {	
lt_ref_pic_poc_lsb_sps[i]	u(v)
used_by_curr_pic_lt_sps_flag[i]	u(1)
}	
}	
sps_temporal_mvp_enabled_flag	u(1)
strong_intra_smoothing_enabled_flag	u(1)
vui_parameters_present_flag	u(1)
if(vui_parameters_present_flag)	
vui_parameters()	
sps_extension_present_flag	u(1)
if(sps_extension_present_flag) {	
sps_range_extension_flag	u(1)

sps_multilayer_extension_flag	u(1)
sps_3d_extension_flag	u(1)
sps_scc_extension_flag	u(1)
sps_extension_4bits	u(4)
}	
if(sps_range_extension_flag)	
sps_range_extension()	
if(sps_multilayer_extension_flag)	
sps_multilayer_extension() /* specified in Annex F */	
if(sps_3d_extension_flag)	
sps_3d_extension() /* specified in Annex I */	
if(sps_scc_extension_flag)	
sps_scc_extension()	
if(sps_extension_4bits)	
while(more_rbsp_data())	
sps_extension_data_flag	u(1)
rbsp_trailing_bits()	
}	

7.3.2.2.2 Sequence parameter set range extension syntax

	Descriptor
sps_range_extension() {	
transform_skip_rotation_enabled_flag	u(1)
transform_skip_context_enabled_flag	u(1)
implicit_rdpcm_enabled_flag	u(1)
explicit_rdpcm_enabled_flag	u(1)
extended_precision_processing_flag	u(1)
intra_smoothing_disabled_flag	u(1)
high_precision_offsets_enabled_flag	u(1)
persistent_rice_adaptation_enabled_flag	u(1)
cabac_bypass_alignment_enabled_flag	u(1)
}	

7.3.2.2.3 Sequence parameter set screen content coding extension syntax

	Descriptor
<code>sps_scc_extension() {</code>	
sps_curr_pic_ref_enabled_flag	u(1)
palette_mode_enabled_flag	u(1)
if(palette_mode_enabled_flag) {	
palette_max_size	ue(v)
delta_palette_max_predictor_size	ue(v)
sps_palette_predictor_initializer_present_flag	u(1)
if(sps_palette_predictor_initializer_present_flag) {	
sps_num_palette_predictor_initializer_minus1	ue(v)
numComps = (chroma_format_idc == 0) ? 1 : 3	
for(comp = 0; comp < numComps; comp++)	
for(i = 0; i <= sps_num_palette_predictor_initializer_minus1; i++)	
sps_palette_predictor_initializers[comp][i]	u(v)
}	
}	
}	
motion_vector_resolution_control_idc	u(2)
intra_boundary_filtering_disabled_flag	u(1)
}	

7.3.2.3 Picture parameter set RBSP syntax

7.3.2.3.1 General picture parameter set RBSP syntax

	Descriptor
<code>pic_parameter_set_rbsp() {</code>	
pps_pic_parameter_set_id	ue(v)
pps_seq_parameter_set_id	ue(v)
dependent_slice_segments_enabled_flag	u(1)
output_flag_present_flag	u(1)
num_extra_slice_header_bits	u(3)
sign_data_hiding_enabled_flag	u(1)
cabac_init_present_flag	u(1)
num_ref_idx_l0_default_active_minus1	ue(v)
num_ref_idx_l1_default_active_minus1	ue(v)
init_qp_minus26	se(v)
constrained_intra_pred_flag	u(1)
transform_skip_enabled_flag	u(1)
cu_qp_delta_enabled_flag	u(1)
if(cu_qp_delta_enabled_flag)	

diff_cu_qp_delta_depth	ue(v)
pps_cb_qp_offset	se(v)
pps_cr_qp_offset	se(v)
pps_slice_chroma_qp_offsets_present_flag	u(1)
weighted_pred_flag	u(1)
weighted_bipred_flag	u(1)
transquant_bypass_enabled_flag	u(1)
tiles_enabled_flag	u(1)
entropy_coding_sync_enabled_flag	u(1)
if(tiles_enabled_flag) {	
num_tile_columns_minus1	ue(v)
num_tile_rows_minus1	ue(v)
uniform_spacing_flag	u(1)
if(!uniform_spacing_flag) {	
for(i = 0; i < num_tile_columns_minus1; i++)	
column_width_minus1[i]	ue(v)
for(i = 0; i < num_tile_rows_minus1; i++)	
row_height_minus1[i]	ue(v)
}	
loop_filter_across_tiles_enabled_flag	u(1)
}	
pps_loop_filter_across_slices_enabled_flag	u(1)
deblocking_filter_control_present_flag	u(1)
if(deblocking_filter_control_present_flag) {	
deblocking_filter_override_enabled_flag	u(1)
pps_deblocking_filter_disabled_flag	u(1)
if(!pps_deblocking_filter_disabled_flag) {	
pps_beta_offset_div2	se(v)
pps_tc_offset_div2	se(v)
}	
}	
pps_scaling_list_data_present_flag	u(1)
if(pps_scaling_list_data_present_flag)	
scaling_list_data()	
lists_modification_present_flag	u(1)
log2_parallel_merge_level_minus2	ue(v)
slice_segment_header_extension_present_flag	u(1)
pps_extension_present_flag	u(1)
if(pps_extension_present_flag) {	

pps_range_extension_flag	u(1)
pps_multilayer_extension_flag	u(1)
pps_3d_extension_flag	u(1)
pps_scc_extension_flag	u(1)
pps_extension_4bits	u(4)
}	
if(pps_range_extension_flag)	
pps_range_extension()	
if(pps_multilayer_extension_flag)	
pps_multilayer_extension() /* specified in Annex F */	
if(pps_3d_extension_flag)	
pps_3d_extension() /* specified in Annex I */	
if(pps_scc_extension_flag)	
pps_scc_extension()	
if(pps_extension_4bits)	
while(more_rbsp_data())	
pps_extension_data_flag	u(1)
rbsp_trailing_bits()	
}	

7.3.2.3.2 Picture parameter set range extension syntax

	Descriptor
pps_range_extension() {	
if(transform_skip_enabled_flag)	
log2_max_transform_skip_block_size_minus2	ue(v)
cross_component_prediction_enabled_flag	u(1)
chroma_qp_offset_list_enabled_flag	u(1)
if(chroma_qp_offset_list_enabled_flag) {	
diff_cu_chroma_qp_offset_depth	ue(v)
chroma_qp_offset_list_len_minus1	ue(v)
for(i = 0; i <= chroma_qp_offset_list_len_minus1; i++) {	
cb_qp_offset_list[i]	se(v)
cr_qp_offset_list[i]	se(v)
}	
}	
log2_sao_offset_scale_luma	ue(v)
log2_sao_offset_scale_chroma	ue(v)
}	

7.3.2.3.3 Picture parameter set screen content coding extension syntax

	Descriptor
pps_scc_extension() {	
pps_curr_pic_ref_enabled_flag	u(1)
residual_adaptive_colour_transform_enabled_flag	u(1)
if(residual_adaptive_colour_transform_enabled_flag) {	
pps_slice_act_qp_offsets_present_flag	u(1)
pps_act_y_qp_offset_plus5	se(v)
pps_act_cb_qp_offset_plus5	se(v)
pps_act_cr_qp_offset_plus3	se(v)
}	
pps_palette_predictor_initializer_present_flag	u(1)
if(pps_palette_predictor_initializer_present_flag) {	
pps_num_palette_predictor_initializer	ue(v)
if(pps_num_palette_predictor_initializer > 0) {	
monochrome_palette_flag	u(1)
luma_bit_depth_entry_minus8	ue(v)
if(!monochrome_palette_flag)	
chroma_bit_depth_entry_minus8	ue(v)
numComps = monochrome_palette_flag ? 1 : 3	
for(comp = 0; comp < numComps; comp++)	
for(i = 0; i < pps_num_palette_predictor_initializer; i++)	
pps_palette_predictor_initializers[comp][i]	u(v)
}	
}	
}	
}	

7.3.2.4 Supplemental enhancement information RBSP syntax

	Descriptor
sei_rbsp() {	
do	
sei_message()	
while(more_rbsp_data())	
rbsp_trailing_bits()	
}	

7.3.2.5 Access unit delimiter RBSP syntax

	Descriptor
access_unit_delimiter_rbsp() {	
pic_type	u(3)
rbsp_trailing_bits()	
}	

7.3.2.6 End of sequence RBSP syntax

end_of_seq_rbsp() {	Descriptor
}	

7.3.2.7 End of bitstream RBSP syntax

end_of_bitstream_rbsp() {	Descriptor
}	

7.3.2.8 Filler data RBSP syntax

filler_data_rbsp() {	Descriptor
while(next_bits(8) == 0xFF)	
ff_byte /* equal to 0xFF */	f(8)
rbsp_trailing_bits()	
}	

7.3.2.9 Slice segment layer RBSP syntax

slice_segment_layer_rbsp() {	Descriptor
slice_segment_header()	
slice_segment_data()	
rbsp_slice_segment_trailing_bits()	
}	

7.3.2.10 RBSP slice segment trailing bits syntax

rbsp_slice_segment_trailing_bits() {	Descriptor
rbsp_trailing_bits()	
while(more_rbsp_trailing_data())	
cabac_zero_word /* equal to 0x0000 */	f(16)
}	

7.3.2.11 RBSP trailing bits syntax

rbsp_trailing_bits() {	Descriptor
rbsp_stop_one_bit /* equal to 1 */	f(1)
while(!byte_aligned())	
rbsp_alignment_zero_bit /* equal to 0 */	f(1)
}	

7.3.2.12 Byte alignment syntax

	Descriptor
byte_alignment() {	
alignment_bit_equal_to_one /* equal to 1 */	f(1)
while(!byte_aligned())	
alignment_bit_equal_to_zero /* equal to 0 */	f(1)
}	

7.3.3 Profile, tier and level syntax

	Descriptor
profile_tier_level(profilePresentFlag, maxNumSubLayersMinus1) {	
if(profilePresentFlag) {	
general_profile_space	u(2)
general_tier_flag	u(1)
general_profile_idc	u(5)
for(j = 0; j < 32; j++)	
general_profile_compatibility_flag[j]	u(1)
general_progressive_source_flag	u(1)
general_interlaced_source_flag	u(1)
general_non_packed_constraint_flag	u(1)
general_frame_only_constraint_flag	u(1)
if(general_profile_idc == 4 general_profile_compatibility_flag[4] general_profile_idc == 5 general_profile_compatibility_flag[5] general_profile_idc == 6 general_profile_compatibility_flag[6] general_profile_idc == 7 general_profile_compatibility_flag[7] general_profile_idc == 8 general_profile_compatibility_flag[8] general_profile_idc == 9 general_profile_compatibility_flag[9] general_profile_idc == 10 general_profile_compatibility_flag[10]) { /* The number of bits in this syntax structure is not affected by this condition */	
general_max_12bit_constraint_flag	u(1)
general_max_10bit_constraint_flag	u(1)
general_max_8bit_constraint_flag	u(1)
general_max_422chroma_constraint_flag	u(1)
general_max_420chroma_constraint_flag	u(1)
general_max_monochrome_constraint_flag	u(1)
general_intra_constraint_flag	u(1)
general_one_picture_only_constraint_flag	u(1)
general_lower_bit_rate_constraint_flag	u(1)
if(general_profile_idc == 5 general_profile_compatibility_flag[5] general_profile_idc == 9 general_profile_compatibility_flag[9] general_profile_idc == 10 general_profile_compatibility_flag[10]) {	
general_max_14bit_constraint_flag	u(1)
general_reserved_zero_33bits	u(33)
} else	

general_reserved_zero_34bits	u(34)
} else	
general_reserved_zero_43bits	u(43)
if((general_profile_idc >= 1 && general_profile_idc <= 5) general_profile_idc == 9 general_profile_compatibility_flag[1] general_profile_compatibility_flag[2] general_profile_compatibility_flag[3] general_profile_compatibility_flag[4] general_profile_compatibility_flag[5] general_profile_compatibility_flag[9]) /* The number of bits in this syntax structure is not affected by this condition */	
general_inbld_flag	u(1)
else	
general_reserved_zero_bit	u(1)
}	
general_level_idc	u(8)
for(i = 0; i < maxNumSubLayersMinus1; i++) {	
sub_layer_profile_present_flag[i]	u(1)
sub_layer_level_present_flag[i]	u(1)
}	
if(maxNumSubLayersMinus1 > 0)	
for(i = maxNumSubLayersMinus1; i < 8; i++)	
reserved_zero_2bits[i]	u(2)
for(i = 0; i < maxNumSubLayersMinus1; i++) {	
if(sub_layer_profile_present_flag[i]) {	
sub_layer_profile_space[i]	u(2)
sub_layer_tier_flag[i]	u(1)
sub_layer_profile_idc[i]	u(5)
for(j = 0; j < 32; j++)	
sub_layer_profile_compatibility_flag[i][j]	u(1)
sub_layer_progressive_source_flag[i]	u(1)
sub_layer_interlaced_source_flag[i]	u(1)
sub_layer_non_packed_constraint_flag[i]	u(1)
sub_layer_frame_only_constraint_flag[i]	u(1)
if(sub_layer_profile_idc[i] == 4 sub_layer_profile_compatibility_flag[i][4] sub_layer_profile_idc[i] == 5 sub_layer_profile_compatibility_flag[i][5] sub_layer_profile_idc[i] == 6 sub_layer_profile_compatibility_flag[i][6] sub_layer_profile_idc[i] == 7 sub_layer_profile_compatibility_flag[i][7] sub_layer_profile_idc[i] == 8 sub_layer_profile_compatibility_flag[i][8] sub_layer_profile_idc[i] == 9 sub_layer_profile_compatibility_flag[i][9] sub_layer_profile_idc[i] == 10 sub_layer_profile_compatibility_flag[i][10]) { /* The number of bits in this syntax structure is not affected by this condition */	
sub_layer_max_12bit_constraint_flag[i]	u(1)
sub_layer_max_10bit_constraint_flag[i]	u(1)

sub_layer_max_8bit_constraint_flag[i]	u(1)
sub_layer_max_422chroma_constraint_flag[i]	u(1)
sub_layer_max_420chroma_constraint_flag[i]	u(1)
sub_layer_max_monochrome_constraint_flag[i]	u(1)
sub_layer_intra_constraint_flag[i]	u(1)
sub_layer_one_picture_only_constraint_flag[i]	u(1)
sub_layer_lower_bit_rate_constraint_flag[i]	u(1)
if(sub_layer_profile_idc == 5 sub_layer_profile_compatibility_flag[5]) {	
sub_layer_max_14bit_constraint_flag	u(1)
sub_layer_reserved_zero_33bits[i]	u(33)
} else	
sub_layer_reserved_zero_34bits[i]	u(34)
} else	
sub_layer_reserved_zero_43bits[i]	u(43)
if((sub_layer_profile_idc[i] >= 1 && sub_layer_profile_idc[i] <= 5) sub_layer_profile_idc[i] == 9 sub_layer_profile_compatibility_flag[1] sub_layer_profile_compatibility_flag[2] sub_layer_profile_compatibility_flag[3] sub_layer_profile_compatibility_flag[4] sub_layer_profile_compatibility_flag[5] sub_layer_profile_compatibility_flag[9]) /* The number of bits in this syntax structure is not affected by this condition */	
sub_layer_inbld_flag[i]	u(1)
else	
sub_layer_reserved_zero_bit[i]	u(1)
}	
if(sub_layer_level_present_flag[i])	
sub_layer_level_idc[i]	u(8)
}	
}	

7.3.4 Scaling list data syntax

	Descriptor
scaling_list_data() {	
for(sizeId = 0; sizeId < 4; sizeId++)	
for(matrixId = 0; matrixId < 6; matrixId += (sizeId == 3) ? 3 : 1) {	
scaling_list_pred_mode_flag[sizeId][matrixId]	u(1)
if(!scaling_list_pred_mode_flag[sizeId][matrixId])	
scaling_list_pred_matrix_id_delta[sizeId][matrixId]	ue(v)
else {	
nextCoef = 8	

coefNum = Min(64, (1 << (4 + (sizeId << 1))))	
if(sizeId > 1) {	
scaling_list_dc_coef_minus8 [sizeId - 2][matrixId]	se(v)
nextCoef = scaling_list_dc_coef_minus8[sizeId - 2][matrixId] + 8	
}	
for(i = 0; i < coefNum; i++) {	
scaling_list_delta_coef	se(v)
nextCoef = (nextCoef + scaling_list_delta_coef + 256) % 256	
ScalingList[sizeId][matrixId][i] = nextCoef	
}	
}	
}	
}	

7.3.5 Supplemental enhancement information message syntax

	Descriptor
sei_message() {	
payloadType = 0	
while(next_bits(8) == 0xFF) {	
ff_byte /* equal to 0xFF */	f(8)
payloadType += 255	
}	
last_payload_type_byte	u(8)
payloadType += last_payload_type_byte	
payloadSize = 0	
while(next_bits(8) == 0xFF) {	
ff_byte /* equal to 0xFF */	f(8)
payloadSize += 255	
}	
last_payload_size_byte	u(8)
payloadSize += last_payload_size_byte	
sei_payload(payloadType, payloadSize)	
}	

7.3.6 Slice segment header syntax

7.3.6.1 General slice segment header syntax

	Descriptor
slice_segment_header() {	
first_slice_segment_in_pic_flag	u(1)
if(nal_unit_type >= BLA_W_LP && nal_unit_type <= RSV_IRAP_VCL23)	
no_output_of_prior_pics_flag	u(1)

slice_pic_parameter_set_id	ue(v)
if(!first_slice_segment_in_pic_flag) {	
if(dependent_slice_segments_enabled_flag)	
dependent_slice_segment_flag	u(1)
slice_segment_address	u(v)
}	
if(!dependent_slice_segment_flag) {	
for(i = 0; i < num_extra_slice_header_bits; i++)	
slice_reserved_flag[i]	u(1)
slice_type	ue(v)
if(output_flag_present_flag)	
pic_output_flag	u(1)
if(separate_colour_plane_flag == 1)	
colour_plane_id	u(2)
if(nal_unit_type != IDR_W_RADL && nal_unit_type != IDR_N_LP) {	
slice_pic_order_cnt_lsb	u(v)
short_term_ref_pic_set_sps_flag	u(1)
if(!short_term_ref_pic_set_sps_flag)	
st_ref_pic_set(num_short_term_ref_pic_sets)	
else if(num_short_term_ref_pic_sets > 1)	
short_term_ref_pic_set_idx	u(v)
if(long_term_ref_pics_present_flag) {	
if(num_long_term_ref_pics_sps > 0)	
num_long_term_sps	ue(v)
num_long_term_pics	ue(v)
for(i = 0; i < num_long_term_sps + num_long_term_pics; i++) {	
if(i < num_long_term_sps) {	
if(num_long_term_ref_pics_sps > 1)	
lt_idx_sps[i]	u(v)
} else {	
poc_lsb_lt[i]	u(v)
used_by_curr_pic_lt_flag[i]	u(1)
}	
delta_poc_msb_present_flag[i]	u(1)
if(delta_poc_msb_present_flag[i])	
delta_poc_msb_cycle_lt[i]	ue(v)
}	
}	
}	
if(sps_temporal_mvp_enabled_flag)	

slice_temporal_mvp_enabled_flag	u(1)
}	
if(sample_adaptive_offset_enabled_flag) {	
slice_sao_luma_flag	u(1)
if(ChromaArrayType != 0)	
slice_sao_chroma_flag	u(1)
}	
if(slice_type == P slice_type == B) {	
num_ref_idx_active_override_flag	u(1)
if(num_ref_idx_active_override_flag) {	
num_ref_idx_l0_active_minus1	ue(v)
if(slice_type == B)	
num_ref_idx_l1_active_minus1	ue(v)
}	
if(lists_modification_present_flag && NumPicTotalCurr > 1)	
ref_pic_lists_modification()	
if(slice_type == B)	
mvd_l1_zero_flag	u(1)
if(cabac_init_present_flag)	
cabac_init_flag	u(1)
if(slice_temporal_mvp_enabled_flag) {	
if(slice_type == B)	
collocated_from_l0_flag	u(1)
if((collocated_from_l0_flag && num_ref_idx_l0_active_minus1 > 0) (!collocated_from_l0_flag && num_ref_idx_l1_active_minus1 > 0))	
collocated_ref_idx	ue(v)
}	
if((weighted_pred_flag && slice_type == P) (weighted_bipred_flag && slice_type == B))	
pred_weight_table()	
five_minus_max_num_merge_cand	ue(v)
if(motion_vector_resolution_control_idc == 2)	
use_integer_mv_flag	u(1)
}	
slice_qp_delta	se(v)
if(pps_slice_chroma_qp_offsets_present_flag) {	
slice_cb_qp_offset	se(v)
slice_cr_qp_offset	se(v)
}	

if(pps_slice_act_qp_offsets_present_flag) {	
slice_act_y_qp_offset	se(v)
slice_act_cb_qp_offset	se(v)
slice_act_cr_qp_offset	se(v)
}	
if(chroma_qp_offset_list_enabled_flag)	
cu_chroma_qp_offset_enabled_flag	u(1)
if(deblocking_filter_override_enabled_flag)	
deblocking_filter_override_flag	u(1)
if(deblocking_filter_override_flag) {	
slice_deblocking_filter_disabled_flag	u(1)
if(!slice_deblocking_filter_disabled_flag) {	
slice_beta_offset_div2	se(v)
slice_tc_offset_div2	se(v)
}	
}	
if(pps_loop_filter_across_slices_enabled_flag && (slice_sao_luma_flag slice_sao_chroma_flag !slice_deblocking_filter_disabled_flag))	
slice_loop_filter_across_slices_enabled_flag	u(1)
}	
if(tiles_enabled_flag entropy_coding_sync_enabled_flag) {	
num_entry_point_offsets	ue(v)
if(num_entry_point_offsets > 0) {	
offset_len_minus1	ue(v)
for(i = 0; i < num_entry_point_offsets; i++)	
entry_point_offset_minus1[i]	u(v)
}	
}	
if(slice_segment_header_extension_present_flag) {	
slice_segment_header_extension_length	ue(v)
for(i = 0; i < slice_segment_header_extension_length; i++)	
slice_segment_header_extension_data_byte[i]	u(8)
}	
byte_alignment()	
}	

7.3.6.2 Reference picture list modification syntax

ref_pic_lists_modification() {	Descriptor
ref_pic_list_modification_flag_l0	u(1)

if(ref_pic_list_modification_flag_l0)	
for(i = 0; i <= num_ref_idx_l0_active_minus1; i++)	
list_entry_l0[i]	u(v)
if(slice_type == B) {	
ref_pic_list_modification_flag_l1	u(1)
if(ref_pic_list_modification_flag_l1)	
for(i = 0; i <= num_ref_idx_l1_active_minus1; i++)	
list_entry_l1[i]	u(v)
}	
}	

7.3.6.3 Weighted prediction parameters syntax

	Descriptor
pred_weight_table() {	
luma_log2_weight_denom	ue(v)
if(ChromaArrayType != 0)	
delta_chroma_log2_weight_denom	se(v)
for(i = 0; i <= num_ref_idx_l0_active_minus1; i++)	
if((pic_layer_id(RefPicList0[i]) != nuh_layer_id) (PicOrderCnt(RefPicList0[i]) != PicOrderCnt(CurrPic)))	
luma_weight_l0_flag[i]	u(1)
if(ChromaArrayType != 0)	
for(i = 0; i <= num_ref_idx_l0_active_minus1; i++)	
if((pic_layer_id(RefPicList0[i]) != nuh_layer_id) (PicOrderCnt(RefPicList0[i]) != PicOrderCnt(CurrPic)))	
chroma_weight_l0_flag[i]	u(1)
for(i = 0; i <= num_ref_idx_l0_active_minus1; i++) {	
if(luma_weight_l0_flag[i]) {	
delta_luma_weight_l0[i]	se(v)
luma_offset_l0[i]	se(v)
}	
if(chroma_weight_l0_flag[i])	
for(j = 0; j < 2; j++) {	
delta_chroma_weight_l0[i][j]	se(v)
delta_chroma_offset_l0[i][j]	se(v)
}	
}	
if(slice_type == B) {	
for(i = 0; i <= num_ref_idx_l1_active_minus1; i++)	
if((pic_layer_id(RefPicList0[i]) != nuh_layer_id) (PicOrderCnt(RefPicList1[i]) != PicOrderCnt(CurrPic)))	

luma_weight_l1_flag[i]	u(1)
if(ChromaArrayType != 0)	
for(i = 0; i <= num_ref_idx_l1_active_minus1; i++)	
if((pic_layer_id(RefPicList0[i]) != nuh_layer_id) (PicOrderCnt(RefPicList1[i]) != PicOrderCnt(CurrPic)))	
chroma_weight_l1_flag[i]	u(1)
for(i = 0; i <= num_ref_idx_l1_active_minus1; i++) {	
if(luma_weight_l1_flag[i]) {	
delta_luma_weight_l1[i]	se(v)
luma_offset_l1[i]	se(y)
}	
if(chroma_weight_l1_flag[i])	
for(j = 0; j < 2; j++) {	
delta_chroma_weight_l1[i][j]	se(v)
delta_chroma_offset_l1[i][j]	se(v)
}	
}	
}	
}	

7.3.7 Short-term reference picture set syntax

	Descriptor
st_ref_pic_set(stRpsIdx) {	
if(stRpsIdx != 0)	
inter_ref_pic_set_prediction_flag	u(1)
if(inter_ref_pic_set_prediction_flag) {	
if(stRpsIdx == num_short_term_ref_pic_sets)	
delta_idx_minus1	ue(v)
delta_rps_sign	u(1)
abs_delta_rps_minus1	ue(v)
for(j = 0; j <= NumDeltaPocs[RefRpsIdx]; j++) {	
used_by_curr_pic_flag[j]	u(1)
if(!used_by_curr_pic_flag[j])	
use_delta_flag[j]	u(1)
}	
} else {	
num_negative_pics	ue(v)
num_positive_pics	ue(v)
for(i = 0; i < num_negative_pics; i++) {	
delta_poc_s0_minus1[i]	ue(v)
used_by_curr_pic_s0_flag[i]	u(1)

}	
for(i = 0; i < num_positive_pics; i++) {	
delta_poc_s1_minus1 [i]	ue(v)
used_by_curr_pic_s1_flag [i]	u(1)
}	
}	
}	

7.3.8 Slice segment data syntax

7.3.8.1 General slice segment data syntax

slice_segment_data() {	Descriptor
do {	
coding_tree_unit()	
end_of_slice_segment_flag	ae(v)
CtbAddrInTs++	
CtbAddrInRs = CtbAddrTsToRs[CtbAddrInTs]	
if(!end_of_slice_segment_flag && ((tiles_enabled_flag && TileId[CtbAddrInTs] != TileId[CtbAddrInTs - 1]) (entropy_coding_sync_enabled_flag && (CtbAddrInRs % PicWidthInCtbsY = = 0 TileId[CtbAddrInTs] != TileId[CtbAddrTsToRs[CtbAddrInRs - 1]]))))){	
end_of_subset_one_bit /* equal to 1 */	ae(v)
byte_alignment()	
}	
} while(!end_of_slice_segment_flag)	
}	

7.3.8.2 Coding tree unit syntax

coding_tree_unit() {	Descriptor
xCtb = (CtbAddrInRs % PicWidthInCtbsY) << CtbLog2SizeY	
yCtb = (CtbAddrInRs / PicWidthInCtbsY) << CtbLog2SizeY	
if(slice_sao_luma_flag slice_sao_chroma_flag)	
sao(xCtb >> CtbLog2SizeY, yCtb >> CtbLog2SizeY)	
coding_quadtree(xCtb, yCtb, CtbLog2SizeY, 0)	
}	

7.3.8.3 Sample adaptive offset syntax

sao(rx, ry) {	Descriptor
if(rx > 0) {	
leftCtbInSliceSeg = CtbAddrInRs > SliceAddrRs	

leftCtbInTile = TileId[CtbAddrInTs] == TileId[CtbAddrRsToTs[CtbAddrInRs - 1]]	
if(leftCtbInSliceSeg && leftCtbInTile)	
sao_merge_left_flag	ae(v)
}	
if(ry > 0 && !sao_merge_left_flag) {	
upCtbInSliceSeg = (CtbAddrInRs - PicWidthInCtbsY) >= SliceAddrRs	
upCtbInTile = TileId[CtbAddrInTs] == TileId[CtbAddrRsToTs[CtbAddrInRs - PicWidthInCtbsY]]	
if(upCtbInSliceSeg && upCtbInTile)	
sao_merge_up_flag	ae(v)
}	
if(!sao_merge_up_flag && !sao_merge_left_flag)	
for(cIdx = 0; cIdx < (ChromaArrayType != 0 ? 3 : 1); cIdx++)	
if((slice_sao_luma_flag && cIdx == 0) (slice_sao_chroma_flag && cIdx > 0)) {	
if(cIdx == 0)	
sao_type_idx_luma	ae(v)
else if(cIdx == 1)	
sao_type_idx_chroma	ae(v)
if(SaoTypeIdx[cIdx][rx][ry] != 0) {	
for(i = 0; i < 4; i++)	
sao_offset_abs [cIdx][rx][ry][i]	ae(v)
if(SaoTypeIdx[cIdx][rx][ry] == 1) {	
for(i = 0; i < 4; i++)	
if(sao_offset_abs[cIdx][rx][ry][i] != 0)	
sao_offset_sign [cIdx][rx][ry][i]	ae(v)
sao_band_position [cIdx][rx][ry]	ae(v)
} else {	
if(cIdx == 0)	
sao_eo_class_luma	ae(v)
if(cIdx == 1)	
sao_eo_class_chroma	ae(v)
}	
}	
}	
}	

7.3.8.4 Coding quadtree syntax

	Descriptor
coding_quadtree(x0, y0, log2CbSize, cqtDepth) {	
if(x0 + (1 << log2CbSize) <= pic_width_in_luma_samples && y0 + (1 << log2CbSize) <= pic_height_in_luma_samples && log2CbSize > MinCbLog2SizeY)	
split_cu_flag [x0][y0]	ae(v)
if(cu_qp_delta_enabled_flag && log2CbSize >= Log2MinCuQpDeltaSize) {	
IsCuQpDeltaCoded = 0	
CuQpDeltaVal = 0	
}	
if(cu_chroma_qp_offset_enabled_flag && log2CbSize >= Log2MinCuChromaQpOffsetSize)	
IsCuChromaQpOffsetCoded = 0	
if(split_cu_flag[x0][y0]) {	
x1 = x0 + (1 << (log2CbSize - 1))	
y1 = y0 + (1 << (log2CbSize - 1))	
coding_quadtree(x0, y0, log2CbSize - 1, cqtDepth + 1)	
if(x1 < pic_width_in_luma_samples)	
coding_quadtree(x1, y0, log2CbSize - 1, cqtDepth + 1)	
if(y1 < pic_height_in_luma_samples)	
coding_quadtree(x0, y1, log2CbSize - 1, cqtDepth + 1)	
if(x1 < pic_width_in_luma_samples && y1 < pic_height_in_luma_samples)	
coding_quadtree(x1, y1, log2CbSize - 1, cqtDepth + 1)	
} else	
coding_unit(x0, y0, log2CbSize)	
}	

7.3.8.5 Coding unit syntax

	Descriptor
coding_unit(x0, y0, log2CbSize) {	
if(transquant_bypass_enabled_flag)	
cu_transquant_bypass_flag	ae(v)
if(slice_type != I)	
cu_skip_flag [x0][y0]	ae(v)
nCbS = (1 << log2CbSize)	
if(cu_skip_flag[x0][y0])	
prediction_unit(x0, y0, nCbS, nCbS)	
else {	
if(slice_type != I)	
pred_mode_flag	ae(v)

if(palette_mode_enabled_flag && CuPredMode[x0][y0] == MODE_INTRA && log2CbSize <= MaxTbLog2SizeY)	
palette_mode_flag [x0][y0]	ae(v)
if(palette_mode_flag[x0][y0])	
palette_coding(x0, y0, nCbS)	
else {	
if(CuPredMode[x0][y0] != MODE_INTRA log2CbSize == MinCbLog2SizeY)	
part_mode	ae(v)
if(CuPredMode[x0][y0] == MODE_INTRA) {	
if(PartMode == PART_2Nx2N && pcm_enabled_flag && log2CbSize >= Log2MinIpcmCbSizeY && log2CbSize <= Log2MaxIpcmCbSizeY)	
pcm_flag [x0][y0]	ae(v)
if(pcm_flag[x0][y0]) {	
while(!byte_aligned())	
pcm_alignment_zero_bit	f(1)
pcm_sample(x0, y0, log2CbSize)	
} else {	
pbOffset = (PartMode == PART_NxN) ? (nCbS > 2) : nCbS	
for(j = 0; j < nCbS; j = j + pbOffset)	
for(i = 0; i < nCbS; i = i + pbOffset)	
prev_intra_luma_pred_flag [x0 + i][y0 + j]	ae(v)
for(j = 0; j < nCbS; j = j + pbOffset)	
for(i = 0; i < nCbS; i = i + pbOffset)	
if(prev_intra_luma_pred_flag[x0 + i][y0 + j])	
mpm_idx [x0 + i][y0 + j]	ae(v)
else	
rem_intra_luma_pred_mode [x0 + i][y0 + j]	ae(v)
if(ChromaArrayType == 3)	
for(j = 0; j < nCbS; j = j + pbOffset)	
for(i = 0; i < nCbS; i = i + pbOffset)	
intra_chroma_pred_mode [x0 + i][y0 + j]	ae(v)
else if(ChromaArrayType != 0)	
intra_chroma_pred_mode[x0][y0]	ae(v)
}	
} else {	
if(PartMode == PART_2Nx2N)	
prediction_unit(x0, y0, nCbS, nCbS)	
else if(PartMode == PART_2NxN) {	

prediction_unit(x0, y0, nCbS, nCbS / 2)	
prediction_unit(x0, y0 + (nCbS / 2), nCbS, nCbS / 2)	
} else if(PartMode == PART_Nx2N) {	
prediction_unit(x0, y0, nCbS / 2, nCbS)	
prediction_unit(x0 + (nCbS / 2), y0, nCbS / 2, nCbS)	
} else if(PartMode == PART_2NxN) {	
prediction_unit(x0, y0, nCbS, nCbS / 4)	
prediction_unit(x0, y0 + (nCbS / 4), nCbS, nCbS * 3 / 4)	
} else if(PartMode == PART_2NxN) {	
prediction_unit(x0, y0, nCbS, nCbS * 3 / 4)	
prediction_unit(x0, y0 + (nCbS * 3 / 4), nCbS, nCbS / 4)	
} else if(PartMode == PART_nLx2N) {	
prediction_unit(x0, y0, nCbS / 4, nCbS)	
prediction_unit(x0 + (nCbS / 4), y0, nCbS * 3 / 4, nCbS)	
} else if(PartMode == PART_nRx2N) {	
prediction_unit(x0, y0, nCbS * 3 / 4, nCbS)	
prediction_unit(x0 + (nCbS * 3 / 4), y0, nCbS / 4, nCbS)	
} else { /* PART_NxN */	
prediction_unit(x0, y0, nCbS / 2, nCbS / 2)	
prediction_unit(x0 + (nCbS / 2), y0, nCbS / 2, nCbS / 2)	
prediction_unit(x0, y0 + (nCbS / 2), nCbS / 2, nCbS / 2)	
prediction_unit(x0 + (nCbS / 2), y0 + (nCbS / 2), nCbS / 2, nCbS / 2)	
}	
}	
if(!pcm_flag[x0][y0]) {	
if(CuPredMode[x0][y0] != MODE_INTRA && !(PartMode == PART_2Nx2N && merge_flag[x0][y0]))	
rqt_root_cbf	ae(v)
if(rqt_root_cbf) {	
MaxTrafoDepth = (CuPredMode[x0][y0] == MODE_INTRA ? (max_transform_hierarchy_depth_intra + IntraSplitFlag) : max_transform_hierarchy_depth_inter)	
transform_tree(x0, y0, x0, y0, log2CbSize, 0, 0)	
}	
}	
}	
}	
}	

7.3.8.6 Prediction unit syntax

	Descriptor
prediction_unit(x0, y0, nPbW, nPbH) {	
if(cu_skip_flag[x0][y0]) {	
if(MaxNumMergeCand > 1)	
merge_idx [x0][y0]	ae(v)
} else { /* MODE_INTER */	
merge_flag [x0][y0]	ae(v)
if(merge_flag[x0][y0]) {	
if(MaxNumMergeCand > 1)	
merge_idx [x0][y0]	ae(v)
} else {	
if(slice_type == B)	
inter_pred_idc [x0][y0]	ae(v)
if(inter_pred_idc[x0][y0] != PRED_L1) {	
if(num_ref_idx_l0_active_minus1 > 0)	
ref_idx_l0 [x0][y0]	ae(v)
mvd_coding(x0, y0, 0)	
mvp_l0_flag [x0][y0]	ae(v)
}	
if(inter_pred_idc[x0][y0] != PRED_L0) {	
if(num_ref_idx_l1_active_minus1 > 0)	
ref_idx_l1 [x0][y0]	ae(v)
if(mvd_l1_zero_flag && inter_pred_idc[x0][y0] == PRED_BI) {	
MvdL1[x0][y0][0] = 0	
MvdL1[x0][y0][1] = 0	
} else	
mvd_coding(x0, y0, 1)	
mvp_l1_flag [x0][y0]	ae(v)
}	
}	
}	
}	
}	
}	

7.3.8.7 PCM sample syntax

	Descriptor
pcm_sample(x0, y0, log2CbSize) {	
for(i = 0; i < 1 << (log2CbSize << 1); i++)	
pcm_sample_luma [i]	u(v)
if(ChromaArrayType != 0)	
for(i = 0; i < ((2 << (log2CbSize << 1)) / (SubWidthC * SubHeightC)); i++)	

pcm_sample_chroma[i]	u(v)
}	

7.3.8.8 Transform tree syntax

	Descriptor
transform_tree(x0, y0, xBase, yBase, log2TrafoSize, trafoDepth, blkIdx) {	
if(log2TrafoSize <= MaxTbLog2SizeY && log2TrafoSize > MinTbLog2SizeY && trafoDepth < MaxTrafoDepth && !(IntraSplitFlag && (trafoDepth == 0)))	
split_transform_flag[x0][y0][trafoDepth]	ae(v)
if((log2TrafoSize > 2 && ChromaArrayType != 0) ChromaArrayType == 3) {	
if(trafoDepth == 0 cbf_cb[xBase][yBase][trafoDepth - 1]) {	
cbf_cb[x0][y0][trafoDepth]	ae(v)
if(ChromaArrayType == 2 && (!split_transform_flag[x0][y0][trafoDepth] log2TrafoSize == 3))	
cbf_cb[x0][y0 + (1 << (log2TrafoSize - 1))][trafoDepth]	ae(v)
}	
if(trafoDepth == 0 cbf_cr[xBase][yBase][trafoDepth - 1]) {	
cbf_cr[x0][y0][trafoDepth]	ae(v)
if(ChromaArrayType == 2 && (!split_transform_flag[x0][y0][trafoDepth] log2TrafoSize == 3))	
cbf_cr[x0][y0 + (1 << (log2TrafoSize - 1))][trafoDepth]	ae(v)
}	
}	
if(split_transform_flag[x0][y0][trafoDepth]) {	
x1 = x0 + (1 << (log2TrafoSize - 1))	
y1 = y0 + (1 << (log2TrafoSize - 1))	
transform_tree(x0, y0, x0, y0, log2TrafoSize - 1, trafoDepth + 1, 0)	
transform_tree(x1, y0, x0, y0, log2TrafoSize - 1, trafoDepth + 1, 1)	
transform_tree(x0, y1, x0, y0, log2TrafoSize - 1, trafoDepth + 1, 2)	
transform_tree(x1, y1, x0, y0, log2TrafoSize - 1, trafoDepth + 1, 3)	
} else {	
if(CuPredMode[x0][y0] == MODE_INTRA trafoDepth != 0 cbf_cb[x0][y0][trafoDepth] cbf_cr[x0][y0][trafoDepth] (ChromaArrayType == 2 && (cbf_cb[x0][y0 + (1 << (log2TrafoSize - 1))][trafoDepth] cbf_cr[x0][y0 + (1 << (log2TrafoSize - 1))][trafoDepth])))	
cbf_luma[x0][y0][trafoDepth]	ae(v)
transform_unit(x0, y0, xBase, yBase, log2TrafoSize, trafoDepth, blkIdx)	
}	
}	

7.3.8.9 Motion vector difference syntax

	Descriptor
<code>mvd_coding(x0, y0, reflist) {</code>	
abs_mvd_greater0_flag[0]	ae(v)
abs_mvd_greater0_flag[1]	ae(v)
if(abs_mvd_greater0_flag[0])	
abs_mvd_greater1_flag[0]	ae(v)
if(abs_mvd_greater0_flag[1])	
abs_mvd_greater1_flag[1]	ae(v)
if(abs_mvd_greater0_flag[0]) {	
if(abs_mvd_greater1_flag[0])	
abs_mvd_minus2[0]	ae(v)
mvd_sign_flag[0]	ae(v)
}	
if(abs_mvd_greater0_flag[1]) {	
if(abs_mvd_greater1_flag[1])	
abs_mvd_minus2[1]	ae(v)
mvd_sign_flag[1]	ae(v)
}	
}	
}	

7.3.8.10 Transform unit syntax

	Descriptor
<code>transform_unit(x0, y0, xBase, yBase, log2TrafoSize, trafoDepth, blkIdx) {</code>	
<code>log2TrafoSizeC = Max(2, log2TrafoSize - (ChromaArrayType == 3 ? 0 : 1))</code>	
<code>cbfDepthC = trafoDepth - (ChromaArrayType != 3 && log2TrafoSize == 2 ? 1 : 0)</code>	
<code>xC = (ChromaArrayType != 3 && log2TrafoSize == 2) ? xBase : x0</code>	
<code>yC = (ChromaArrayType != 3 && log2TrafoSize == 2) ? yBase : y0</code>	
<code>cbfLuma = cbf_luma[x0][y0][trafoDepth]</code>	
<code>cbfChroma =</code> <code> cbf_cb[xC][yC][cbfDepthC] </code> <code> cbf_cr[xC][yC][cbfDepthC] </code> <code> (ChromaArrayType == 2 &&</code> <code> [cbf_cb[xC][yC + (1 << log2TrafoSizeC)][cbfDepthC] </code> <code> cbf_cr[xC][yC + (1 << log2TrafoSizeC)][cbfDepthC]))</code>	
if(cbfLuma cbfChroma) {	
<code>xP = (x0 >> MinCbLog2SizeY) << MinCbLog2SizeY</code>	
<code>yP = (y0 >> MinCbLog2SizeY) << MinCbLog2SizeY</code>	
<code>nCbS = 1 << MinCbLog2SizeY</code>	

<pre> if(residual_adaptive_colour_transform_enabled_flag && (CuPredMode[x0][y0] == MODE_INTER (PartMode == PART_2Nx2N && intra_chroma_pred_mode[x0][y0] == 4) (intra_chroma_pred_mode[xP][yP] == 4 && intra_chroma_pred_mode[xP + nCbS/2][yP] == 4 && intra_chroma_pred_mode[xP][yP + nCbS/2] == 4 && intra_chroma_pred_mode[xP + nCbS/2][yP + nCbS/2] == 4))) </pre>	
tu_residual_act_flag [x0][y0]	ae(v)
delta_qp()	
if(cbfChroma && !cu_transquant_bypass_flag)	
chroma_qp_offset()	
if(cbfLuma)	
residual_coding(x0, y0, log2TrafoSize, 0)	
if(log2TrafoSize > 2 ChromaArrayType == 3) {	
<pre> if(cross_component_prediction_enabled_flag && cbfLuma && (CuPredMode[x0][y0] == MODE_INTER intra_chroma_pred_mode[x0][y0] == 4)) </pre>	
cross_comp_pred(x0, y0, 0)	
for(tIdx = 0; tIdx < (ChromaArrayType == 2 ? 2 : 1); tIdx++)	
if(cbf_cb[x0][y0 + (tIdx << log2TrafoSizeC)][trafoDepth])	
residual_coding(x0, y0 + (tIdx << log2TrafoSizeC), log2TrafoSizeC, 1)	
<pre> if(cross_component_prediction_enabled_flag && cbfLuma && (CuPredMode[x0][y0] == MODE_INTER intra_chroma_pred_mode[x0][y0] == 4)) </pre>	
cross_comp_pred(x0, y0, 1)	
for(tIdx = 0; tIdx < (ChromaArrayType == 2 ? 2 : 1); tIdx++)	
if(cbf_cr[x0][y0 + (tIdx << log2TrafoSizeC)][trafoDepth])	
residual_coding(x0, y0 + (tIdx << log2TrafoSizeC), log2TrafoSizeC, 2)	
} else if(blkIdx == 3) {	
for(tIdx = 0; tIdx < (ChromaArrayType == 2 ? 2 : 1); tIdx++)	
if(cbf_cb[xBase][yBase + (tIdx << log2TrafoSizeC)][trafoDepth - 1])	
residual_coding(xBase, yBase + (tIdx << log2TrafoSizeC), log2TrafoSize, 1)	
for(tIdx = 0; tIdx < (ChromaArrayType == 2 ? 2 : 1); tIdx++)	
if(cbf_cr[xBase][yBase + (tIdx << log2TrafoSizeC)][trafoDepth - 1])	
residual_coding(xBase, yBase + (tIdx << log2TrafoSizeC), log2TrafoSize, 2)	
}	
}	
}	

7.3.8.11 Residual coding syntax

	Descriptor
residual_coding(x0, y0, log2TrafoSize, cIdx) {	
if(transform_skip_enabled_flag && !cu_transquant_bypass_flag && (log2TrafoSize <= Log2MaxTransformSkipSize))	
transform_skip_flag [x0][y0][cIdx]	ae(v)
if(CuPredMode[x0][y0] = MODE_INTER && explicit_rdpkm_enabled_flag && (transform_skip_flag[x0][y0][cIdx] cu_transquant_bypass_flag)) {	
explicit_rdpkm_flag [x0][y0][cIdx]	ae(v)
if(explicit_rdpkm_flag[x0][y0][cIdx])	
explicit_rdpkm_dir_flag [x0][y0][cIdx]	ae(v)
}	
last_sig_coeff_x_prefix	ae(v)
last_sig_coeff_y_prefix	ae(v)
if(last_sig_coeff_x_prefix > 3)	
last_sig_coeff_x_suffix	ae(v)
if(last_sig_coeff_y_prefix > 3)	
last_sig_coeff_y_suffix	ae(v)
lastScanPos = 16	
lastSubBlock = (1 << (log2TrafoSize - 2)) * (1 << (log2TrafoSize - 2)) - 1	
do {	
if(lastScanPos == 0) {	
lastScanPos = 16	
lastSubBlock--	
}	
lastScanPos--	
xS = ScanOrder[log2TrafoSize - 2][scanIdx][lastSubBlock][0]	
yS = ScanOrder[log2TrafoSize - 2][scanIdx][lastSubBlock][1]	
xC = (xS << 2) + ScanOrder[2][scanIdx][lastScanPos][0]	
yC = (yS << 2) + ScanOrder[2][scanIdx][lastScanPos][1]	
} while((xC != LastSignificantCoeffX) (yC != LastSignificantCoeffY))	
for(i = lastSubBlock; i >= 0; i--) {	
xS = ScanOrder[log2TrafoSize - 2][scanIdx][i][0]	
yS = ScanOrder[log2TrafoSize - 2][scanIdx][i][1]	
escapeDataPresent = 0	
inferSbDcSigCoeffFlag = 0	
if((i < lastSubBlock) && (i > 0)) {	
coded_sub_block_flag [xS][yS]	ae(v)
inferSbDcSigCoeffFlag = 1	
}	

for(n = (i = lastSubBlock) ? lastScanPos - 1 : 15; n >= 0; n--) {	
xC = (xS << 2) + ScanOrder[2][scanIdx][n][0]	
yC = (yS << 2) + ScanOrder[2][scanIdx][n][1]	
if(coded_sub_block_flag[xS][yS] && (n > 0 !inferSbDcSigCoeffFlag)) {	
sig_coeff_flag [xC][yC]	ae(v)
if(sig_coeff_flag[xC][yC])	
inferSbDcSigCoeffFlag = 0	
}	
}	
firstSigScanPos = 16	
lastSigScanPos = -1	
numGreater1Flag = 0	
lastGreater1ScanPos = -1	
for(n = 15; n >= 0; n--) {	
xC = (xS << 2) + ScanOrder[2][scanIdx][n][0]	
yC = (yS << 2) + ScanOrder[2][scanIdx][n][1]	
if(sig_coeff_flag[xC][yC]) {	
if(numGreater1Flag < 8) {	
coeff_abs_level_greater1_flag [n]	ae(v)
numGreater1Flag++	
if(coeff_abs_level_greater1_flag[n] && lastGreater1ScanPos == -1)	
lastGreater1ScanPos = n	
else if(coeff_abs_level_greater1_flag[n])	
escapeDataPresent = 1	
} else	
escapeDataPresent = 1	
if(lastSigScanPos == -1)	
lastSigScanPos = n	
firstSigScanPos = n	
}	
}	
if(cu_transquant_bypass_flag (CuPredMode[x0][y0] == MODE_INTRA && implicit_rdpcm_enabled_flag && transform_skip_flag[x0][y0][cldx] && (predModeIntra == 10 predModeIntra == 26)) explicit_rdpcm_flag[x0][y0][cldx])	
signHidden = 0	
else	
signHidden = lastSigScanPos - firstSigScanPos > 3	
if(lastGreater1ScanPos != -1) {	
coeff_abs_level_greater2_flag [lastGreater1ScanPos]	ae(v)

if(coeff_abs_level_greater2_flag[lastGreater1ScanPos])	
escapeDataPresent = 1	
}	
for(n = 15; n >= 0; n--) {	
xC = (xS << 2) + ScanOrder[2][scanIdx][n][0]	
yC = (yS << 2) + ScanOrder[2][scanIdx][n][1]	
if(sig_coeff_flag[xC][yC] && (!sign_data_hiding_enabled_flag !signHidden (n != firstSigScanPos)))	
coeff_sign_flag[n]	ae(v)
}	
numSigCoeff = 0	
sumAbsLevel = 0	
for(n = 15; n >= 0; n--) {	
xC = (xS << 2) + ScanOrder[2][scanIdx][n][0]	
yC = (yS << 2) + ScanOrder[2][scanIdx][n][1]	
if(sig_coeff_flag[xC][yC]) {	
baseLevel = 1 + coeff_abs_level_greater1_flag[n] + coeff_abs_level_greater2_flag[n]	
if(baseLevel == ((numSigCoeff < 8) ? (n == lastGreater1ScanPos) ? 3 : 2) : 1))	
coeff_abs_level_remaining[n]	ae(v)
TransCoeffLevel[x0][y0][cIdx][xC][yC] = (coeff_abs_level_remaining[n] + baseLevel) * (1 - 2 * coeff_sign_flag[n])	
if(sign_data_hiding_enabled_flag && signHidden) {	
sumAbsLevel += (coeff_abs_level_remaining[n] + baseLevel)	
if((n == firstSigScanPos) && ((sumAbsLevel % 2) == 1))	
TransCoeffLevel[x0][y0][cIdx][xC][yC] = -TransCoeffLevel[x0][y0][cIdx][xC][yC]	
}	
numSigCoeff++	
}	
}	
}	
}	

7.3.8.12 Cross-component prediction syntax

cross_comp_pred(x0, y0, c) {	Descriptor
log2_res_scale_abs_plus1[c]	ae(v)
if(log2_res_scale_abs_plus1[c] != 0)	
res_scale_sign_flag[c]	ae(v)
}	

7.3.8.13 Palette syntax

	Descriptor
palette_coding(x0, y0, nCbS) {	
palettePredictionFinished = 0	
NumPredictedPaletteEntries = 0	
for(predictorEntryIdx = 0; predictorEntryIdx < PredictorPaletteSize && !palettePredictionFinished && NumPredictedPaletteEntries < palette_max_size; predictorEntryIdx++) {	
palette_predictor_run	ae(v)
if(palette_predictor_run != 1) {	
if(palette_predictor_run > 1)	
predictorEntryIdx += palette_predictor_run - 1	
PalettePredictorEntryReuseFlags[predictorEntryIdx] = 1	
NumPredictedPaletteEntries++	
} else	
palettePredictionFinished = 1	
}	
if(NumPredictedPaletteEntries < palette_max_size)	
num_signalled_palette_entries	ae(v)
numComps = (ChromaArrayType == 0) ? 1 : 3	
for(cIdx = 0; cIdx < numComps; cIdx++)	
for(i = 0; i < num_signalled_palette_entries; i++)	
new_palette_entries [cIdx][i]	ae(v)
if(CurrentPaletteSize != 0)	
palette_escape_val_present_flag	ae(v)
if(MaxPaletteIndex > 0) {	
num_palette_indices_minus1	ae(v)
adjust = 0	
for(i = 0; i <= num_palette_indices_minus1; i++) {	
if(MaxPaletteIndex - adjust > 0) {	
palette_index_idc	ae(v)
PaletteIndexIdc[i] = palette_index_idc	
}	
adjust = 1	
}	
copy_above_indices_for_final_run_flag	ae(v)
palette_transpose_flag	ae(v)
}	
if(palette_escape_val_present_flag) {	
delta_qp()	

if (!cu_transquant_bypass_flag)	
chroma_qp_offset()	
}	
remainingNumIndices = num_palette_indices_minus1 + 1	
PaletteScanPos = 0	
log2BlockSize = Log2(nCbS)	
while(PaletteScanPos < nCbS * nCbS) {	
xC = x0 + ScanOrder[log2BlockSize][3][PaletteScanPos][0]	
yC = y0 + ScanOrder[log2BlockSize][3][PaletteScanPos][1]	
if(PaletteScanPos > 0) {	
xcPrev = x0 + ScanOrder[log2BlockSize][3][PaletteScanPos - 1][0]	
ycPrev = y0 + ScanOrder[log2BlockSize][3][PaletteScanPos - 1][1]	
}	
PaletteRun = nCbS * nCbS - PaletteScanPos - 1	
CopyAboveIndicesFlag[xC][yC] = 0	
if(MaxPaletteIndex > 0)	
if(PaletteScanPos >= nCbS && CopyAboveIndicesFlag[xcPrev][ycPrev] == 0)	
if(remainingNumIndices > 0 && PaletteScanPos < nCbS * nCbS - 1) {	
copy_above_palette_indices_flag	ae(v)
CopyAboveIndicesFlag[xC][yC] = copy_above_palette_indices_flag	
} else	
if(PaletteScanPos == nCbS * nCbS - 1 && remainingNumIndices > 0)	
CopyAboveIndicesFlag[xC][yC] = 0	
else	
CopyAboveIndicesFlag[xC][yC] = 1	
if (CopyAboveIndicesFlag[xC][yC] == 0) {	
currNumIndices = num_palette_indices_minus1 + 1 - remainingNumIndices	
CurrPaletteIndex = PaletteIndexIdc[currNumIndices]	
}	
if(MaxPaletteIndex > 0) {	
if (CopyAboveIndicesFlag[xC][yC] == 0)	
remainingNumIndices - = 1	
PaletteMaxRun = nCbS * nCbS - PaletteScanPos - 1 - remainingNumIndices - copy_above_indices_for_final_run_flag	
if(remainingNumIndices > 0 CopyAboveIndicesFlag[xC][yC] != copy_above_indices_for_final_run_flag)	
if(PaletteMaxRun > 0) {	
palette_run_prefix	ae(v)
if((palette_run_prefix > 1) && (PaletteMaxRun != (1 << (palette_run_prefix - 1))))	

palette_run_suffix	ae(v)
}	
}	
runPos = 0	
while (runPos <= PaletteRun) {	
xR = x0 + ScanOrder[log2BlockSize][3][PaletteScanPos][0]	
yR = y0 + ScanOrder[log2BlockSize][3][PaletteScanPos][1]	
if(CopyAboveIndicesFlag[xC][yC] == 0) {	
CopyAboveIndicesFlag[xR][yR] = 0	
PaletteIndexMap[xR][yR] = CurrPaletteIndex	
} else {	
CopyAboveIndicesFlag[xR][yR] = 1	
PaletteIndexMap[xR][yR] = PaletteIndexMap[xR][yR - 1]	
}	
runPos++	
PaletteScanPos++	
}	
}	
if(palette_escape_val_present_flag) {	
for(cIdx = 0; cIdx < numComps; cIdx++)	
for(sPos = 0; sPos < nCbS * nCbS; sPos++) {	
xC = x0 + ScanOrder[log2BlockSize][3][sPos][0]	
yC = y0 + ScanOrder[log2BlockSize][3][sPos][1]	
if(PaletteIndexMap[xC][yC] == MaxPaletteIndex)	
if(cIdx == 0 (xC % 2 == 0 && yC % 2 == 0 && ChromaArrayType == 1) (xC % 2 == 0 && !palette_transpose_flag && ChromaArrayType == 2) (yC % 2 == 0 && palette_transpose_flag && ChromaArrayType == 2) ChromaArrayType == 3) {	
palette_escape_val	ae(v)
PaletteEscapeVal[cIdx][xC][yC] = palette_escape_val	
}	
}	
}	
}	
}	

7.3.8.14 Delta QP syntax

delta_qp() {	Descriptor
if(cu_qp_delta_enabled_flag && !IsCuQpDeltaCoded) {	
cu_qp_delta_abs	ae(v)
if(cu_qp_delta_abs)	

cu_qp_delta_sign_flag	ae(v)
}	
}	

7.3.8.15 Chroma QP offset syntax

	Descriptor
chroma_qp_offset() {	
if(cu_chroma_qp_offset_enabled_flag && !IsCuChromaQpOffsetCoded) {	
cu_chroma_qp_offset_flag	ae(v)
if(cu_chroma_qp_offset_flag && chroma_qp_offset_list_len_minus1 > 0)	
cu_chroma_qp_offset_idx	ae(v)
}	
}	
}	

7.4 Semantics

7.4.1 General

Semantics associated with the syntax structures and with the syntax elements within these structures are specified in this subclause. When the semantics of a syntax element are specified using a table or a set of tables, values that are not specified in the table(s) shall not be present in the bitstream unless otherwise specified in this document.

7.4.2 NAL unit semantics

7.4.2.1 General NAL unit semantics

NumBytesInNalUnit specifies the size of the NAL unit in bytes. This value is required for decoding of the NAL unit. Some form of demarcation of NAL unit boundaries is necessary to enable inference of NumBytesInNalUnit. One such demarcation method is specified in Annex B for the byte stream format. Other methods of demarcation may be specified outside of this document.

NOTE 1 The VCL is specified to efficiently represent the content of the video data. The NAL is specified to format that data and provide header information in a manner appropriate for conveyance on a variety of communication channels or storage media. All data are contained in NAL units, each of which contains an integer number of bytes. A NAL unit specifies a generic format for use in both packet-oriented and bitstream systems. The format of NAL units for both packet-oriented transport and byte stream is identical except that each NAL unit can be preceded by a start code prefix and extra padding bytes in the byte stream format specified in Annex B.

rbsp_byte[i] is the i-th byte of an RBSP. An RBSP is specified as an ordered sequence of bytes as follows:

The RBSP contains an SODB as follows:

- If the SODB is empty (i.e. zero bits in length), the RBSP is also empty.
- Otherwise, the RBSP contains the SODB as follows:
 - The first byte of the RBSP contains the (most significant, left-most) eight bits of the SODB; the next byte of the RBSP contains the next eight bits of the SODB, etc., until fewer than eight bits of the SODB remain.
 - **rbsp_trailing_bits**() are present after the SODB as follows:
 - The first (most significant, left-most) bits of the final RBSP byte contains the remaining bits of the SODB (if any).

ISO/IEC 23008-2:2017(E)

- The next bit consists of a single `rbsp_stop_one_bit` equal to 1.
- When the `rbsp_stop_one_bit` is not the last bit of a byte-aligned byte, one or more `rbsp_alignment_zero_bit` is present to result in byte alignment.
- One or more `cabac_zero_word` 16-bit syntax elements equal to 0x0000 may be present in some RBSPs after the `rbsp_trailing_bits()` at the end of the RBSP.

Syntax structures having these RBSP properties are denoted in the syntax tables using an “_rbsp” suffix. These structures are carried within NAL units as the content of the `rbsp_byte[i]` data bytes. The association of the RBSP syntax structures to the NAL units is as specified in Table 7-1.

NOTE 2 When the boundaries of the RBSP are known, the decoder can extract the SODB from the RBSP by concatenating the bits of the bytes of the RBSP and discarding the `rbsp_stop_one_bit`, which is the last (least significant, right-most) bit equal to 1, and discarding any following (less significant, farther to the right) bits that follow it, which are equal to 0. The data necessary for the decoding process is contained in the SODB part of the RBSP.

emulation_prevention_three_byte is a byte equal to 0x03. When an `emulation_prevention_three_byte` is present in the NAL unit, it shall be discarded by the decoding process.

The last byte of the NAL unit shall not be equal to 0x00.

Within the NAL unit, the following three-byte sequences shall not occur at any byte-aligned position:

- 0x000000;
- 0x000001;
- 0x000002.

Within the NAL unit, any four-byte sequence that starts with 0x000003 other than the following sequences shall not occur at any byte-aligned position:

- 0x00000300;
- 0x00000301;
- 0x00000302;
- 0x00000303.

7.4.2.2 NAL unit header semantics

forbidden_zero_bit shall be equal to 0.

nal_unit_type specifies the type of RBSP data structure contained in the NAL unit as specified in Table 7-1.

NAL units that have `nal_unit_type` in the range of UNSPEC48..UNSPEC63, inclusive, for which semantics are not specified, shall not affect the decoding process specified in this document.

NOTE 1 NAL unit types in the range of UNSPEC48..UNSPEC63 can be used as determined by the application. No decoding process for these values of `nal_unit_type` is specified in this document. Since different applications might use these NAL unit types for different purposes, particular care must be exercised in the design of encoders that generate NAL units with these `nal_unit_type` values, and in the design of decoders that interpret the content of NAL units with these `nal_unit_type` values.

For purposes other than determining the amount of data in the decoding units of the bitstream (as specified in Annex C), decoders shall ignore (remove from the bitstream and discard) the contents of all NAL units that use reserved values of `nal_unit_type`.

NOTE 2 This requirement allows future definition of compatible extensions to this document.

Table 7-1 — NAL unit type codes and NAL unit type classes

nal_unit_type	Name of nal_unit_type	Content of NAL unit and RBSP syntax structure	NAL unit type class
0 1	TRAIL_N TRAIL_R	Coded slice segment of a non-TSA, non-STSA trailing picture slice_segment_layer_rbsp()	VCL
2 3	TSA_N TSA_R	Coded slice segment of a TSA picture slice_segment_layer_rbsp()	VCL
4 5	STSA_N STSA_R	Coded slice segment of an STSA picture slice_segment_layer_rbsp()	VCL
6 7	RADL_N RADL_R	Coded slice segment of a RADL picture slice_segment_layer_rbsp()	VCL
8 9	RASL_N RASL_R	Coded slice segment of a RASL picture slice_segment_layer_rbsp()	VCL
10 12 14	RSV_VCL_N10 RSV_VCL_N12 RSV_VCL_N14	Reserved non-IRAP SLNR VCL NAL unit types	VCL
11 13 15	RSV_VCL_R11 RSV_VCL_R13 RSV_VCL_R15	Reserved non-IRAP sub-layer reference VCL NAL unit types	VCL
16 17 18	BLA_W_LP BLA_W_RADL BLA_N_LP	Coded slice segment of a BLA picture slice_segment_layer_rbsp()	VCL
19 20	IDR_W_RADL IDR_N_LP	Coded slice segment of an IDR picture slice_segment_layer_rbsp()	VCL
21	CRA_NUT	Coded slice segment of a CRA picture slice_segment_layer_rbsp()	VCL
22 23	RSV_IRAP_VCL22 RSV_IRAP_VCL23	Reserved IRAP VCL NAL unit types	VCL
24..31	RSV_VCL24. RSV_VCL31	Reserved non-IRAP VCL NAL unit types	VCL
32	VPS_NUT	Video parameter set video_parameter_set_rbsp()	non-VCL
33	SPS_NUT	Sequence parameter set seq_parameter_set_rbsp()	non-VCL
34	PPS_NUT	Picture parameter set pic_parameter_set_rbsp()	non-VCL
35	AUD_NUT	Access unit delimiter access_unit_delimiter_rbsp()	non-VCL
36	EOS_NUT	End of sequence end_of_seq_rbsp()	non-VCL
37	EOB_NUT	End of bitstream end_of_bitstream_rbsp()	non-VCL
38	FD_NUT	Filler data filler_data_rbsp()	non-VCL
39	PREFIX_SEI_NUT	Supplemental enhancement information	non-VCL

ISO/IEC 23008-2:2017(E)

40	SUFFIX_SEI_NUT	sei_rbsp()	
41..47	RSV_NVCL41.. RSV_NVCL47	Reserved	non-VCL
48..63	UNSPEC48.. UNSPEC63	Unspecified	non-VCL

NOTE 3 A CRA picture may have associated RASL or RADL pictures present in the bitstream.

NOTE 4 A BLA picture having nal_unit_type equal to BLA_W_LP may have associated RASL or RADL pictures present in the bitstream. A BLA picture having nal_unit_type equal to BLA_W_RADL does not have associated RASL pictures present in the bitstream, but may have associated RADL pictures in the bitstream. A BLA picture having nal_unit_type equal to BLA_N_LP does not have associated leading pictures present in the bitstream.

NOTE 5 An IDR picture having nal_unit_type equal to IDR_N_LP does not have associated leading pictures present in the bitstream. An IDR picture having nal_unit_type equal to IDR_W_RADL does not have associated RASL pictures present in the bitstream, but may have associated RADL pictures in the bitstream.

NOTE 6 An SLNR picture is not included in any of RefPicSetStCurrBefore, RefPicSetStCurrAfter and RefPicSetLtCurr of any picture with the same value of TemporalId, and may be discarded without affecting the decodability of other pictures with the same value of TemporalId.

All coded slice segment NAL units of an access unit shall have the same value of nal_unit_type. A picture or an access unit is also referred to as having a nal_unit_type equal to the nal_unit_type of the coded slice segment NAL units of the picture or access unit.

If a picture has nal_unit_type equal to TRAIL_N, TSA_N, STSA_N, RADL_N, RASL_N, RSV_VCL_N10, RSV_VCL_N12, or RSV_VCL_N14, the picture is an SLNR picture. Otherwise, the picture is a sub-layer reference picture.

Each picture, other than the first picture in the bitstream in decoding order, is considered to be associated with the previous IRAP picture in decoding order.

When a picture is a leading picture, it shall be a RADL or RASL picture.

When a picture is a trailing picture, it shall not be a RADL or RASL picture.

When a picture is a leading picture, it shall precede, in decoding order, all trailing pictures that are associated with the same IRAP picture.

No RASL pictures shall be present in the bitstream that are associated with a BLA picture having nal_unit_type equal to BLA_W_RADL or BLA_N_LP.

No RASL pictures shall be present in the bitstream that are associated with an IDR picture.

No RADL pictures shall be present in the bitstream that are associated with a BLA picture having nal_unit_type equal to BLA_N_LP or that are associated with an IDR picture having nal_unit_type equal to IDR_N_LP.

NOTE 7 It is possible to perform random access at the position of an IRAP access unit by discarding all access units before the IRAP access unit (and to correctly decode the IRAP picture and all the subsequent non-RASL pictures in decoding order), provided each parameter set is available (either in the bitstream or by external means not specified in this document) when it needs to be activated.

Any picture that has PicOutputFlag equal to 1 that precedes an IRAP picture in decoding order shall precede the IRAP picture in output order and shall precede any RADL picture associated with the IRAP picture in output order.

Any RASL picture associated with a CRA or BLA picture shall precede any RADL picture associated with the CRA or BLA picture in output order.

Any RASL picture associated with a CRA picture shall follow, in output order, any IRAP picture that precedes the CRA picture in decoding order.

When `sps_temporal_id_nesting_flag` is equal to 1 and `TemporalId` is greater than 0, the `nal_unit_type` shall be equal to `TSA_R`, `TSA_N`, `RADL_R`, `RADL_N`, `RASL_R`, or `RASL_N`.

nuh_layer_id specifies the identifier of the layer to which a VCL NAL unit belongs or the identifier of a layer to which a non-VCL NAL unit applies. The value of `nuh_layer_id` shall be in the range of 0 to 62, inclusive. The value of 63 may be specified in the future by ITU-T | ISO/IEC. For purposes other than determining the amount of data in the decoding units of the bitstream, decoders shall ignore all data that follow the value 63 for `nuh_layer_id` in a NAL unit, and decoders conforming to a profile specified in Annex A and not supporting the INBLD capability specified in Annex F shall ignore (i.e. remove from the bitstream and discard) all NAL units with values of `nuh_layer_id` not equal to 0.

NOTE 8 The value of 63 for `nuh_layer_id` may be used to indicate an extended layer identifier in a future extension of this document.

The value of `nuh_layer_id` shall be the same for all VCL NAL units of a coded picture. The value of `nuh_layer_id` of a coded picture is the value of the `nuh_layer_id` of the VCL NAL units of the coded picture.

When `nal_unit_type` is equal to `EOB_NUT`, the value of `nuh_layer_id` shall be equal to 0.

nuh_temporal_id_plus1 minus 1 specifies a temporal identifier for the NAL unit. The value of `nuh_temporal_id_plus1` shall not be equal to 0.

The variable `TemporalId` is specified as follows:

$$\text{TemporalId} = \text{nuh_temporal_id_plus1} - 1 \quad (7-1)$$

When `nal_unit_type` is in the range of `BLA_W_LP` to `RSV_IRAP_VCL23`, inclusive, i.e. the coded slice segment belongs to an IRAP picture, `TemporalId` shall be equal to 0.

When `nal_unit_type` is equal to `TSA_R` or `TSA_N`, `TemporalId` shall not be equal to 0.

When `nuh_layer_id` is equal to 0 and `nal_unit_type` is equal to `STSA_R` or `STSA_N`, `TemporalId` shall not be equal to 0.

The value of `TemporalId` shall be the same for all VCL NAL units of an access unit. The value of `TemporalId` of a coded picture or an access unit is the value of the `TemporalId` of the VCL NAL units of the coded picture or the access unit. The value of `TemporalId` of a sub-layer representation is the greatest value of `TemporalId` of all VCL NAL units in the sub-layer representation.

The value of `TemporalId` for non-VCL NAL units is constrained as follows:

- If `nal_unit_type` is equal to `VPS_NUT` or `SPS_NUT`, `TemporalId` shall be equal to 0 and the `TemporalId` of the access unit containing the NAL unit shall be equal to 0.
- Otherwise, if `nal_unit_type` is equal to `EOS_NUT` or `EOB_NUT`, `TemporalId` shall be equal to 0.
- Otherwise, if `nal_unit_type` is equal to `AUD_NUT` or `FD_NUT`, `TemporalId` shall be equal to the `TemporalId` of the access unit containing the NAL unit.
- Otherwise, `TemporalId` shall be greater than or equal to the `TemporalId` of the access unit containing the NAL unit.

NOTE 9 When the NAL unit is a non-VCL NAL unit, the value of `TemporalId` is equal to the minimum value of the `TemporalId` values of all access units to which the non-VCL NAL unit applies. When `nal_unit_type` is equal to `PPS_NUT`, `TemporalId` may be greater than or equal to the `TemporalId` of the containing access unit, as all PPSs may be included in the beginning of a bitstream, wherein the first coded picture has `TemporalId` equal to 0. When `nal_unit_type` is equal to `PREFIX_SEI_NUT` or `SUFFIX_SEI_NUT`, `TemporalId` may be greater than or equal to the `TemporalId` of the containing access unit, as an SEI NAL unit may contain information, e.g. in a buffering period SEI message or a picture timing SEI message, that applies to a bitstream subset that includes access units for which the `TemporalId` values are greater than the `TemporalId` of the access unit containing the SEI NAL unit.

ISO/IEC 23008-2:2017(E)

7.4.2.3 Encapsulation of an SODB within an RBSP (informative)

This subclause does not form an integral part of this document.

The form of encapsulation of an SODB within an RBSP and the use of the emulation_prevention_three_byte for encapsulation of an RBSP within a NAL unit is described for the following purposes:

- to prevent the emulation of start codes within NAL units while allowing any arbitrary SODB to be represented within a NAL unit;
- to enable identification of the end of the SODB within the NAL unit by searching the RBSP for the rbsp_stop_one_bit starting at the end of the RBSP;
- to enable a NAL unit to have a size greater than that of the SODB under some circumstances (using one or more cabac_zero_word syntax elements).

The encoder can produce a NAL unit from an RBSP by the following procedure.

1. The RBSP data are searched for byte-aligned bits of the following binary patterns:

'00000000 00000000 000000xx' (where 'xx' represents any two-bit pattern: '00', '01', '10', or '11'),

and a byte equal to 0x03 is inserted to replace the bit pattern with the pattern:

'00000000 00000000 00000011 000000xx',

and finally, when the last byte of the RBSP data is equal to 0x00 (which can only occur when the RBSP ends in a cabac_zero_word), a final byte equal to 0x03 is appended to the end of the data. The last zero byte of a byte-aligned three-byte sequence 0x000000 in the RBSP (which is replaced by the four-byte sequence 0x00000300) is taken into account when searching the RBSP data for the next occurrence of byte-aligned bits with the binary patterns specified above.

2. The resulting sequence of bytes is then prefixed with the NAL unit header, within which the nal_unit_type indicates the type of RBSP data structure in the NAL unit.

The process specified above results in the construction of the entire NAL unit.

This process can allow any SODB to be represented in a NAL unit while ensuring both of the following.

- No byte-aligned start code prefix is emulated within the NAL unit.
- No sequence of 8 zero-valued bits followed by a start code prefix, regardless of byte-alignment, is emulated within the NAL unit.

7.4.2.4 Order of NAL units and association to coded pictures, access units, and coded video sequences

7.4.2.4.1 General

This subclause specifies constraints on the order of NAL units in the bitstream.

Any order of NAL units in the bitstream obeying these constraints is referred to in the text as the decoding order of NAL units. Within a NAL unit, the syntax in 7.3, D.2, and E.2 specifies the decoding order of syntax elements. Decoders shall be capable of receiving NAL units and their syntax elements in decoding order.

7.4.2.4.2 Order of VPS, SPS, PPS RBSPs and their activation

This subclause specifies the activation process of VPSs, SPSs, and PPSs.

NOTE 1 The VPS, SPS, and PPS mechanism decouples the transmission of infrequently changing information from the transmission of coded block data. VPSs, SPSs, and PPSs may, in some applications, be conveyed “out-of-band”.

A PPS RBSP includes parameters that can be referred to by the coded slice segment NAL units of one or more coded pictures. Each PPS RBSP is initially considered not active for the base layer at the start of the operation of the decoding process. At most one PPS RBSP is considered active for the base layer at any given moment during the operation of the decoding process, and the activation of any particular PPS RBSP for the base layer results in the deactivation of the previously-active PPS RBSP for the base layer (if any).

When a PPS RBSP (with a particular value of `pps_pic_parameter_set_id`) is not active for the base layer and it is referred to by a coded slice segment NAL unit with `nuh_layer_id` equal to 0 (using a value of `slice_pic_parameter_set_id` equal to the `pps_pic_parameter_set_id` value), it is activated for the base layer. This PPS RBSP is called the active PPS RBSP for the base layer until it is deactivated by the activation of another PPS RBSP for the base layer. A PPS RBSP, with that particular value of `pps_pic_parameter_set_id`, shall be available to the decoding process prior to its activation, included in at least one access unit with `TemporalId` less than or equal to the `TemporalId` of the PPS NAL unit or provided through external means, and the PPS NAL unit containing the PPS RBSP shall have `nuh_layer_id` equal to 0.

Any PPS NAL unit containing the value of `pps_pic_parameter_set_id` for the active PPS RBSP for a coded picture (and consequently for the layer containing the coded picture) shall have the same content as that of the active PPS RBSP for the coded picture, unless it follows the last VCL NAL unit of the coded picture and precedes the first VCL NAL unit of another coded picture.

An SPS RBSP includes parameters that can be referred to by one or more PPS RBSPs or one or more SEI NAL units containing an active parameter sets SEI message. Each SPS RBSP is initially considered not active for the base layer at the start of the operation of the decoding process. At most, one SPS RBSP is considered active for the base layer at any given moment during the operation of the decoding process, and the activation of any particular SPS RBSP for the base layer results in the deactivation of the previously-active SPS RBSP for the base layer (if any).

When an SPS RBSP (with a particular value of `sps_seq_parameter_set_id`) is not already active for the base layer and it is referred to by an activation of a PPS RBSP (in which `pps_seq_parameter_set_id` is equal to the `sps_seq_parameter_set_id` value) for the base layer or, when `vps_base_layer_internal_flag` is equal to 1 and `vps_base_layer_available_flag` is equal to 1, is referred to by an SEI NAL unit containing an active parameter sets SEI message (in which `active_seq_parameter_set_id[0]` is equal to the `sps_seq_parameter_set_id` value), it is activated for the base layer. This SPS RBSP is called the active SPS RBSP for the base layer until it is deactivated by the activation of another SPS RBSP for the base layer. An SPS RBSP, with that particular value of `sps_seq_parameter_set_id`, shall be available to the decoding process prior to its activation, included in at least one access unit with `TemporalId` equal to 0 or provided through external means, and the SPS NAL unit containing the SPS RBSP shall have `nuh_layer_id` equal to 0. An activated SPS RBSP for the base layer shall remain active for the entire CVS.

NOTE 2 Because an IRAP access unit with `NoRasOutputFlag` equal to 1 begins a new CVS and an activated SPS RBSP for the base layer must remain active for the entire CVS, an SPS RBSP can only be activated for the base layer by an active parameter sets SEI message when the active parameter sets SEI message is part of an IRAP access unit with `NoRasOutputFlag` equal to 1.

Any SPS NAL unit with `nuh_layer_id` equal to 0 containing the value of `sps_seq_parameter_set_id` for the active SPS RBSP for the base layer for a CVS shall have the same content as that of the active SPS RBSP for the base layer for the CVS, unless it follows the last access unit of the CVS and precedes the first VCL NAL unit and the first SEI NAL unit containing an active parameter sets SEI message (when present) of another CVS.

ISO/IEC 23008-2:2017(E)

A VPS RBSP includes parameters that can be referred to by one or more SPS RBSPs or one or more SEI NAL units containing an active parameter sets SEI message. Each VPS RBSP is initially considered not active at the start of the operation of the decoding process. At most one VPS RBSP is considered active at any given moment during the operation of the decoding process, and the activation of any particular VPS RBSP results in the deactivation of the previously-active VPS RBSP (if any).

When a VPS RBSP (with a particular value of `vps_video_parameter_set_id`) is not already active and it is referred to by activation of an SPS RBSP (in which `sps_video_parameter_set_id` is equal to the `vps_video_parameter_set_id` value) for the base layer, or is referred to by an SEI NAL unit containing an active parameter sets SEI message (in which `active_video_parameter_set_id` is equal to the `vps_video_parameter_set_id` value), it is activated. This VPS RBSP is called the active VPS RBSP until it is deactivated by the activation of another VPS RBSP. A VPS RBSP, with that particular value of `vps_video_parameter_set_id`, shall be available to the decoding process prior to its activation, included in at least one access unit with `TemporalId` equal to 0 or provided through external means, and the VPS NAL unit containing the VPS RBSP shall have `nuh_layer_id` equal to 0. An activated VPS RBSP shall remain active for the entire CVS.

NOTE 3 Because an IRAP access unit with `NoRaslOutputFlag` equal to 1 begins a new CVS and an activated VPS RBSP must remain active for the entire CVS, a VPS RBSP can only be activated by an active parameter sets SEI message when the active parameter sets SEI message is part of an IRAP access unit with `NoRaslOutputFlag` equal to 1.

Any VPS NAL unit containing the value of `vps_video_parameter_set_id` for the active VPS RBSP for a CVS shall have the same content as that of the active VPS RBSP for the CVS, unless it follows the last access unit of the CVS and precedes the first VCL NAL unit, the first SPS NAL unit, and the first SEI NAL unit containing an active parameter sets SEI message (when present) of another CVS.

NOTE 4 If VPS RBSP, SPS RBSP, or PPS RBSP are conveyed within the bitstream, these constraints impose an order constraint on the NAL units that contain the VPS RBSP, SPS RBSP, or PPS RBSP, respectively. Otherwise (VPS RBSP, SPS RBSP, or PPS RBSP are conveyed by other means not specified in this document), they must be available to the decoding process in a timely fashion such that these constraints are obeyed.

All constraints that are expressed on the relationship between the values of the syntax elements and the values of variables derived from those syntax elements in VPSs, SPSs, and PPSs and other syntax elements are expressions of constraints that apply only to the active VPS RBSP, the active SPS RBSP for the base layer, and the active PPS RBSP for the base layer. If any VPS RBSP, SPS RBSP, and PPS RBSP is present that is never activated in the bitstream, its syntax elements shall have values that would conform to the specified constraints if it was activated by reference in an otherwise conforming bitstream.

NOTE 5 In the context of this subclause, activation of a parameter set RBSP is for the base layer only. Thus, the constraint above on never-activated parameter set RBSPs applies to those parameter set RBSPs with `nuh_layer_id` equal to 0 only, because parameter set RBSPs with `nuh_layer_id` greater than 0 are not allowed to be referred to by the base layer.

During operation of the decoding process (see Clause 8), the values of parameters of the active VPS RBSP, the active SPS RBSP for the base layer, and the active PPS RBSP for the base layer are considered in effect. For interpretation of SEI messages, the values of the active VPS RBSP, the active SPS RBSP for the base layer, and the active PPS RBSP for the base layer for the operation of the decoding process for the VCL NAL units of the coded picture with `nuh_layer_id` equal to 0 in the same access unit are considered in effect unless otherwise specified in the SEI message semantics.

7.4.2.4.3 Order of access units and association to CVSs

A bitstream conforming to this document consists of one or more CVSs.

A CVS consists of one or more access units. The order of NAL units and coded pictures and their association to access units is described in 7.4.2.4.4.

The first access unit of a CVS is an IRAP access unit with `NoRaslOutputFlag` equal to 1.

It is a requirement of bitstream conformance that, when present, the next access unit after an access unit that contains an end of sequence NAL unit or an end of bitstream NAL unit shall be an IRAP access unit, which may be an IDR access unit, a BLA access unit, or a CRA access unit.

7.4.2.4.4 Order of NAL units and coded pictures and their association to access units

This subclause specifies the order of NAL units and coded pictures and their association to access units for CVSs that conform to one or more of the profiles specified in Annex A and that are decoded using the decoding process specified in Clauses 2 through 10.

An access unit consists of one coded picture with `nuh_layer_id` equal to 0, zero or more VCL NAL units with `nuh_layer_id` greater than 0, and zero or more non-VCL NAL units. The association of VCL NAL units to coded pictures is described in 7.4.2.4.5.

The first access unit in the bitstream starts with the first NAL unit of the bitstream.

Let `firstBIPicNalUnit` be the first VCL NAL unit of a coded picture with `nuh_layer_id` equal to 0. The first of any of the following NAL units preceding `firstBIPicNalUnit` and succeeding the last VCL NAL unit preceding `firstBIPicNalUnit`, if any, specifies the start of a new access unit.

NOTE 1 The last VCL NAL unit preceding `firstBIPicNalUnit` in decoding order may have `nuh_layer_id` greater than 0.

- access unit delimiter NAL unit with `nuh_layer_id` equal to 0 (when present);
- VPS NAL unit with `nuh_layer_id` equal to 0 (when present);
- SPS NAL unit with `nuh_layer_id` equal to 0 (when present);
- PPS NAL unit with `nuh_layer_id` equal to 0 (when present);
- Prefix SEI NAL unit with `nuh_layer_id` equal to 0 (when present);
- NAL units with `nal_unit_type` in the range of RSV_NVCL41..RSV_NVCL44 with `nuh_layer_id` equal to 0 (when present);
- NAL units with `nal_unit_type` in the range of UNSPEC48..UNSPEC55 with `nuh_layer_id` equal to 0 (when present).

NOTE 2 The first NAL unit preceding `firstBIPicNalUnit` and succeeding the last VCL NAL unit preceding `firstBIPicNalUnit`, if any, can only be one of the above-listed NAL units.

When there is none of the above NAL units preceding `firstBIPicNalUnit` and succeeding the last VCL NAL unit preceding `firstBIPicNalUnit`, if any, `firstBIPicNalUnit` starts a new access unit.

The order of the coded pictures and non-VCL NAL units within an access unit shall obey the following constraints.

- When an access unit delimiter NAL unit with `nuh_layer_id` equal to 0 is present, it shall be the first NAL unit. There shall be at most one access unit delimiter NAL unit with `nuh_layer_id` equal to 0 in any access unit.
- When any VPS NAL units, SPS NAL units, PPS NAL units, prefix SEI NAL units, NAL units with `nal_unit_type` in the range of RSV_NVCL41..RSV_NVCL44, or NAL units with `nal_unit_type` in the range of UNSPEC48..UNSPEC55 are present, they shall not follow the last VCL NAL unit of the access unit.
- NAL units having `nal_unit_type` equal to FD_NUT or SUFFIX_SEI_NUT, or in the range of RSV_NVCL45..RSV_NVCL47 or UNSPEC56..UNSPEC63 shall not precede the first VCL NAL unit of the access unit.

ISO/IEC 23008-2:2017(E)

- When an end of sequence NAL unit with `nuh_layer_id` equal to 0 is present, it shall be the last NAL unit among all NAL units with `nuh_layer_id` equal to 0 in the access unit other than an end of bitstream NAL unit (when present).
- When an end of bitstream NAL unit is present, it shall be the last NAL unit in the access unit.

NOTE 3 Decoders conforming to profiles specified in Annex A do not use NAL units with `nuh_layer_id` greater than 0, e.g. access unit delimiter NAL units with `nuh_layer_id` greater than 0, for access unit boundary detection, except for identification of a NAL unit as a VCL or non-VCL NAL unit. Consequently, HRD parameters carried in non-nested buffering period, picture timing, and decoding unit information SEI messages apply to access units based on such access unit boundary detection.

The structure of access units not containing any NAL units with `nal_unit_type` equal to `FD_NUT`, `VPS_NUT`, `SPS_NUT`, `PPS_NUT`, `RSV_VCL_N10`, `RSV_VCL_R11`, `RSV_VCL_N12`, `RSV_VCL_R13`, `RSV_VCL_N14`, or `RSV_VCL_R15`, `RSV_IRAP_VCL22`, or `RSV_IRAP_VCL23`, or in the range of `RSV_VCL24..RSV_VCL31`, `RSV_NVCL41..RSV_NVCL47`, or `UNSPEC48..UNSPEC63` is shown in Figure 7-1.

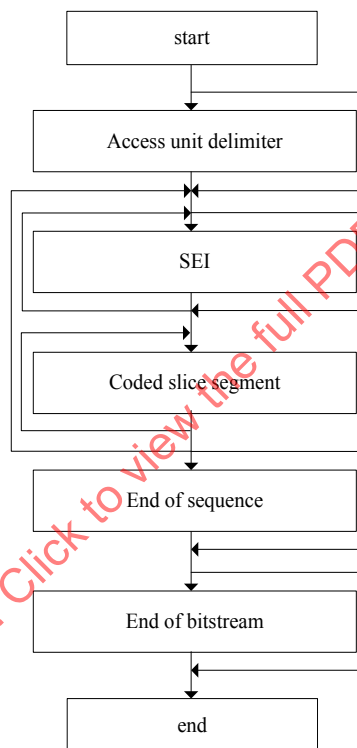

Figure 7-1 — Structure of an access unit not containing any NAL units with `nal_unit_type` equal to `FD_NUT`, `SUFFIX_SEI_NUT`, `VPS_NUT`, `SPS_NUT`, `PPS_NUT`, `RSV_VCL_N10`, `RSV_VCL_R11`, `RSV_VCL_N12`, `RSV_VCL_R13`, `RSV_VCL_N14`, `RSV_VCL_R15`, `RSV_IRAP_VCL22`, or `RSV_IRAP_VCL23`, or in the range of `RSV_VCL24..RSV_VCL31`, `RSV_NVCL41..RSV_NVCL47`, or `UNSPEC48..UNSPEC63`

7.4.2.4.5 Order of VCL NAL units and association to coded pictures

This subclause specifies the order of VCL NAL units and association to coded pictures.

Each VCL NAL unit is part of a coded picture.

The order of the VCL NAL units within a coded picture is constrained as follows.

- The first VCL NAL unit of the coded picture shall have `first_slice_segment_in_pic_flag` equal to 1.

- Let sliceSegAddrA and sliceSegAddrB be the slice_segment_address values of any two coded slice segment NAL units A and B within the same coded picture. When either of the following conditions is true, coded slice segment NAL unit A shall precede the coded slice segment NAL unit B:
 - TileId[CtbAddrRsToTs[sliceSegAddrA]] is less than TileId[CtbAddrRsToTs[sliceSegAddrB]];
 - TileId[CtbAddrRsToTs[sliceSegAddrA]] is equal to TileId[CtbAddrRsToTs[sliceSegAddrB]] and CtbAddrRsToTs[sliceSegAddrA] is less than CtbAddrRsToTs[sliceSegAddrB] .

7.4.3 Raw byte sequence payloads, trailing bits, and byte alignment semantics

7.4.3.1 Video parameter set RBSP semantics

NOTE 1 VPS NAL units are required to be available to the decoding process prior to their activation (either in the bitstream or by external means), as specified in 7.4.2.4.2. However, the VPS RBSP contains information that is not necessary for operation of the decoding process specified in Clauses 2 through 10. For purposes other than determining the amount of data in the decoding units of the bitstream (as specified in Annex C), decoders conforming to a profile specified in Annex A but not supporting the INBLD capability specified in Annex F can ignore (remove from the bitstream and discard) the content of all VPS NAL units.

Any two instances of the syntax structure hrd_parameters() included in a VPS RBSP shall not have the same content.

vps_video_parameter_set_id identifies the VPS for reference by other syntax elements.

vps_base_layer_internal_flag and **vps_base_layer_available_flag** specify the following.

- If vps_base_layer_internal_flag is equal to 1 and vps_base_layer_available_flag is equal to 1, the base layer is present in the bitstream.
- Otherwise, if vps_base_layer_internal_flag is equal to 0 and vps_base_layer_available_flag is equal to 1, the base layer is provided by an external means not specified in this document.
- Otherwise, if vps_base_layer_internal_flag is equal to 1 and vps_base_layer_available_flag is equal to 0, the base layer is not available (neither present in the bitstream nor provided by external means) but the VPS includes information of the base layer as if it were present in the bitstream.
- Otherwise (vps_base_layer_internal_flag is equal to 0 and vps_base_layer_available_flag is equal to 0), the base layer is not available (neither present in the bitstream nor provided by external means) but the VPS includes information of the base layer as if it were provided by an external means not specified in this document.

vps_max_layers_minus1 plus 1 specifies the maximum allowed number of layers in each CVS referring to the VPS. It is a requirement of bitstream conformance that, when vps_base_layer_internal_flag is equal to 0, vps_max_layers_minus1 shall be greater than 0. vps_max_layers_minus1 shall be less than 63 in bitstreams conforming to this version of this document. The value of 63 for vps_max_layers_minus1 is reserved for future use by ITU-T | ISO/IEC. Although the value of vps_max_layers_minus1 is required to be less than 63 in this version of this document, decoders shall allow the value of vps_max_layers_minus1 equal to 63 to appear in the syntax.

NOTE 2 The value of 63 for vps_max_layers_minus1 may be used to indicate an extended number of layers in a future extension where more than 63 layers in a bitstream need to be supported.

The variable MaxLayersMinus1 is set equal to Min(62, vps_max_layers_minus1).

vps_max_sub_layers_minus1 plus 1 specifies the maximum number of temporal sub-layers that may be present in each CVS referring to the VPS. The value of vps_max_sub_layers_minus1 shall be in the range of 0 to 6, inclusive.

vps_temporal_id_nesting_flag, when `vps_max_sub_layers_minus1` is greater than 0, specifies whether inter prediction is additionally restricted for CVSs referring to the VPS. When `vps_max_sub_layers_minus1` is equal to 0, `vps_temporal_id_nesting_flag` shall be equal to 1.

NOTE 3 The syntax element `vps_temporal_id_nesting_flag` is used to indicate that temporal sub-layer up-switching, i.e. switching from decoding of up to any TemporalId tIdN to decoding up to any TemporalId tIdM that is greater than tIdN, is always possible.

vps_reserved_0xffff_16bits shall be equal to 0xFFFF in bitstreams conforming to this version of this document. Other values for `vps_reserved_0xffff_16bits` are reserved for future use by ITU-T | ISO/IEC. Decoders shall ignore the value of `vps_reserved_0xffff_16bits`.

vps_sub_layer_ordering_info_present_flag equal to 1 specifies that `vps_max_dec_pic_buffering_minus1[i]`, `vps_max_num_reorder_pics[i]`, and `vps_max_latency_increase_plus1[i]` are present for `vps_max_sub_layers_minus1 + 1` sub-layers. `vps_sub_layer_ordering_info_present_flag` equal to 0 specifies that the values of `vps_max_dec_pic_buffering_minus1[vps_max_sub_layers_minus1]`, `vps_max_num_reorder_pics[vps_max_sub_layers_minus1]`, and `vps_max_latency_increase_plus1[vps_max_sub_layers_minus1]` apply to all sub-layers. When `vps_base_layer_internal_flag` is equal to 0, `vps_sub_layer_ordering_info_present_flag` shall be equal to 0, and decoders shall ignore the value of `vps_sub_layer_ordering_info_present_flag`.

vps_max_dec_pic_buffering_minus1[i] plus 1 specifies the maximum required size of the decoded picture buffer for the CVS in units of picture storage buffers when `HighestTid` is equal to `i`. The value of `vps_max_dec_pic_buffering_minus1[i]` shall be in the range of 0 to `MaxDpbSize - 1` (as specified in A.4), inclusive. When `i` is greater than 0, `vps_max_dec_pic_buffering_minus1[i]` shall be greater than or equal to `vps_max_dec_pic_buffering_minus1[i - 1]`. When `vps_max_dec_pic_buffering_minus1[i]` is not present for `i` in the range of 0 to `vps_max_sub_layers_minus1 - 1`, inclusive, due to `vps_sub_layer_ordering_info_present_flag` being equal to 0, it is inferred to be equal to `vps_max_dec_pic_buffering_minus1[vps_max_sub_layers_minus1]`. When `vps_base_layer_internal_flag` is equal to 0, `vps_max_dec_pic_buffering_minus1[i]` shall be equal to 0, and decoders shall ignore the value of `vps_max_dec_pic_buffering_minus1[i]`.

vps_max_num_reorder_pics[i] indicates the maximum allowed number of pictures with `PicOutputFlag` equal to 1 that can precede any picture with `PicOutputFlag` equal to 1 in the CVS in decoding order and follow that picture with `PicOutputFlag` equal to 1 in output order when `HighestTid` is equal to `i`. The value of `vps_max_num_reorder_pics[i]` shall be in the range of 0 to `vps_max_dec_pic_buffering_minus1[i]`, inclusive. When `i` is greater than 0, `vps_max_num_reorder_pics[i]` shall be greater than or equal to `vps_max_num_reorder_pics[i - 1]`. When `vps_max_num_reorder_pics[i]` is not present for `i` in the range of 0 to `vps_max_sub_layers_minus1 - 1`, inclusive, due to `vps_sub_layer_ordering_info_present_flag` being equal to 0, it is inferred to be equal to `vps_max_num_reorder_pics[vps_max_sub_layers_minus1]`. When `vps_base_layer_internal_flag` is equal to 0, `vps_max_num_reorder_pics[i]` shall be equal to 0, and decoders shall ignore the value of `vps_max_num_reorder_pics[i]`.

vps_max_latency_increase_plus1[i] not equal to 0 is used to compute the value of `VpsMaxLatencyPictures[i]`, which specifies the maximum number of pictures with `PicOutputFlag` equal to 1 that can precede any picture with `PicOutputFlag` equal to 1 in the CVS in output order and follow that picture with `PicOutputFlag` equal to 1 in decoding order when `HighestTid` is equal to `i`.

When `vps_max_latency_increase_plus1[i]` is not equal to 0, the value of `VpsMaxLatencyPictures[i]` is specified as follows:

$$\text{VpsMaxLatencyPictures}[i] = \text{vps_max_num_reorder_pics}[i] + \text{vps_max_latency_increase_plus1}[i] - 1 \quad (7-2)$$

When `vps_max_latency_increase_plus1[i]` is equal to 0, no corresponding limit is expressed.

The value of `vps_max_latency_increase_plus1[i]` shall be in the range of 0 to $2^{32} - 2$, inclusive. When `vps_max_latency_increase_plus1[i]` is not present for `i` in the range of 0 to `vps_max_sub_layers_minus1 - 1`, inclusive, due to `vps_sub_layer_ordering_info_present_flag` being equal to 0, it is inferred to be equal to `vps_max_latency_increase_plus1[vps_max_sub_layers_minus1]`.

When `vps_base_layer_internal_flag` is equal to 0, `vps_max_latency_increase_plus1[i]` shall be equal to 0, and decoders shall ignore the value of `vps_max_latency_increase_plus1[i]`.

vps_max_layer_id specifies the maximum allowed value of `nuh_layer_id` of all NAL units in each CVS referring to the VPS. `vps_max_layer_id` shall be less than 63 in bitstreams conforming to this version of this document. The value of 63 for `vps_max_layer_id` is reserved for future use by ITU-T | ISO/IEC. Although the value of `vps_max_layer_id` is required to be less than 63 in this version of this document, decoders shall allow a value of `vps_max_layer_id` equal to 63 to appear in the syntax.

vps_num_layer_sets_minus1 plus 1 specifies the number of layer sets that are specified by the VPS. The value of `vps_num_layer_sets_minus1` shall be in the range of 0 to 1023, inclusive.

layer_id_included_flag[i][j] equal to 1 specifies that the value of `nuh_layer_id` equal to `j` is included in the layer identifier list `LayerSetLayerIdList[i]`. **layer_id_included_flag[i][j]** equal to 0 specifies that the value of `nuh_layer_id` equal to `j` is not included in the layer identifier list `LayerSetLayerIdList[i]`.

The value of `NumLayersInIdList[0]` is set equal to 1 and the value of `LayerSetLayerIdList[0][0]` is set equal to 0.

For each value of `i` in the range of 1 to `vps_num_layer_sets_minus1`, inclusive, the variable `NumLayersInIdList[i]` and the layer identifier list `LayerSetLayerIdList[i]` are derived as follows:

```
n = 0
for( m = 0; m <= vps_max_layer_id; m++ )
    if( layer_id_included_flag[ i ][ m ] )
        LayerSetLayerIdList[ i ][ n++ ] = m
NumLayersInIdList[ i ] = n
```

(7-3)

For each value of `i` in the range of 1 to `vps_num_layer_sets_minus1`, inclusive, `NumLayersInIdList[i]` shall be in the range of 1 to `vps_max_sub_layers_minus1 + 1`, inclusive.

When `NumLayersInIdList[iA]` is equal to `NumLayersInIdList[iB]` for any `iA` and `iB` in the range of 0 to `vps_num_layer_sets_minus1`, inclusive, with `iA` not equal to `iB`, the value of `LayerSetLayerIdList[iA][n]` shall not be equal to `LayerSetLayerIdList[iB][n]` for at least one value of `n` in the range of 0 to `NumLayersInIdList[iA]`, inclusive.

A layer set is identified by the associated layer identifier list. The `i`-th layer set specified by the VPS is associated with the layer identifier list `LayerSetLayerIdList[i]`, for `i` in the range of 0 to `vps_num_layer_sets_minus1`, inclusive.

A layer set consists of all operation points that are associated with the same layer identifier list.

Each operation point is identified by the associated layer identifier list, denoted as `OpLayerIdList`, which consists of the list of `nuh_layer_id` values of all NAL units included in the operation point, in increasing order of `nuh_layer_id` values, and a variable `OpTid`, which is equal to the highest `TemporalId` of all NAL units included in the operation point. The bitstream subset associated with the operation point identified by `OpLayerIdList` and `OpTid` is the output of the sub-bitstream extraction process as specified in Clause 10 with the bitstream, the target highest `TemporalId` equal to `OpTid`, and the target layer identifier list equal to `OpLayerIdList` as inputs. The `OpLayerIdList` and `OpTid` that identify an operation point are also referred to as the `OpLayerIdList` and `OpTid` associated with the operation point, respectively.

vps_timing_info_present_flag equal to 1 specifies that `vps_num_units_in_tick`, `vps_time_scale`, `vps_poc_proportional_to_timing_flag`, and `vps_num_hrd_parameters` are present in the VPS. **vps_timing_info_present_flag** equal to 0 specifies that `vps_num_units_in_tick`, `vps_time_scale`, `vps_poc_proportional_to_timing_flag`, and `vps_num_hrd_parameters` are not present in the VPS.

vps_num_units_in_tick is the number of time units of a clock operating at the frequency `vps_time_scale` Hz that corresponds to one increment (called a clock tick) of a clock tick counter. The value of `vps_num_units_in_tick` shall be greater than 0. A clock tick, in units of seconds, is equal to the quotient of `vps_num_units_in_tick` divided by `vps_time_scale`. For example, when the picture rate of a video signal is 25 Hz, `vps_time_scale` may be equal to 27 000 000 and `vps_num_units_in_tick` may be equal to 1 080 000, and consequently a clock tick may be 0.04 s.

vps_time_scale is the number of time units that pass in one second. For example, a time coordinate system that measures time using a 27 MHz clock has a `vps_time_scale` of 27 000 000. The value of `vps_time_scale` shall be greater than 0.

vps_poc_proportional_to_timing_flag equal to 1 indicates that the picture order count value for each picture in the CVS that is not the first picture in the CVS, in decoding order, is proportional to the output time of the picture relative to the output time of the first picture in the CVS. `vps_poc_proportional_to_timing_flag` equal to 0 indicates that the picture order count value for each picture in the CVS that is not the first picture in the CVS, in decoding order, may or may not be proportional to the output time of the picture relative to the output time of the first picture in the CVS.

vps_num_ticks_poc_diff_one_minus1 plus 1 specifies the number of clock ticks corresponding to a difference of picture order count values equal to 1. The value of `vps_num_ticks_poc_diff_one_minus1` shall be in the range of 0 to $2^{32} - 2$, inclusive.

vps_num_hrd_parameters specifies the number of `hrd_parameters()` syntax structures present in the VPS RBSP before the `vps_extension_flag` syntax element. The value of `vps_num_hrd_parameters` shall be in the range of 0 to `vps_num_layer_sets_minus1` + 1, inclusive.

hrd_layer_set_idx[i] specifies the index, into the list of layer sets specified by the VPS, of the layer set to which the *i*-th `hrd_parameters()` syntax structure in the VPS applies. The value of `hrd_layer_set_idx[i]` shall be in the range of (`vps_base_layer_internal_flag` ? 0 : 1) to `vps_num_layer_sets_minus1`, inclusive.

It is a requirement of bitstream conformance that the value of `hrd_layer_set_idx[i]` shall not be equal to the value of `hrd_layer_set_idx[j]` for any value of *j* not equal to *i*.

cprms_present_flag[i] equal to 1 specifies that the HRD parameters that are common for all sub-layers are present in the *i*-th `hrd_parameters()` syntax structure in the VPS. `cprms_present_flag[i]` equal to 0 specifies that the HRD parameters that are common for all sub-layers are not present in the *i*-th `hrd_parameters()` syntax structure in the VPS and are derived to be the same as the (*i* - 1)-th `hrd_parameters()` syntax structure in the VPS. `cprms_present_flag[0]` is inferred to be equal to 1.

vps_extension_flag equal to 0 specifies that no `vps_extension_data_flag` syntax elements are present in the VPS RBSP syntax structure. `vps_extension_flag` equal to 1 specifies that there are `vps_extension_data_flag` syntax elements present in the VPS RBSP syntax structure. Decoders conforming to a profile specified in Annex A but not supporting the INBLD capability specified in Annex F shall ignore all data that follow the value 1 for `vps_extension_flag` in a VPS NAL unit.

vps_extension_data_flag may have any value. Its presence and value do not affect decoder conformance to profiles specified in Annex A. Decoders conforming to a profile specified in Annex A but not supporting the INBLD capability specified in Annex F shall ignore all `vps_extension_data_flag` syntax elements.

7.4.3.2 Sequence parameter set RBSP semantics

7.4.3.2.1 General sequence parameter set RBSP semantics

sps_video_parameter_set_id specifies the value of the `vps_video_parameter_set_id` of the active VPS.

sps_max_sub_layers_minus1 plus 1 specifies the maximum number of temporal sub-layers that may be present in each CVS referring to the SPS. The value of `sps_max_sub_layers_minus1` shall be in the range of 0 to 6, inclusive. The value of `sps_max_sub_layers_minus1` shall be less than or equal to `vps_max_sub_layers_minus1`.

sps_temporal_id_nesting_flag, when `sps_max_sub_layers_minus1` is greater than 0, specifies whether inter prediction is additionally restricted for CVSs referring to the SPS. When `vps_temporal_id_nesting_flag` is equal to 1, `sps_temporal_id_nesting_flag` shall be equal to 1. When `sps_max_sub_layers_minus1` is equal to 0, `sps_temporal_id_nesting_flag` shall be equal to 1.

NOTE 1 The syntax element `sps_temporal_id_nesting_flag` is used to indicate that temporal up-switching, i.e. switching from decoding up to any TemporalId `tIdN` to decoding up to any TemporalId `tIdM` that is greater than `tIdN`, is always possible in the CVS.

sps_seq_parameter_set_id provides an identifier for the SPS for reference by other syntax elements. The value of `sps_seq_parameter_set_id` shall be in the range of 0 to 15, inclusive.

chroma_format_idc specifies the chroma sampling relative to the luma sampling as specified in 6.2. The value of `chroma_format_idc` shall be in the range of 0 to 3, inclusive.

separate_colour_plane_flag equal to 1 specifies that the three colour components of the 4:4:4 chroma format are coded separately. `separate_colour_plane_flag` equal to 0 specifies that the colour components are not coded separately. When `separate_colour_plane_flag` is not present, it is inferred to be equal to 0. When `separate_colour_plane_flag` is equal to 1, the coded picture consists of three separate components, each of which consists of coded samples of one colour plane (Y, Cb, or Cr) and uses the monochrome coding syntax. In this case, each colour plane is associated with a specific `colour_plane_id` value.

NOTE 2 There is no dependency in decoding processes between the colour planes having different `colour_plane_id` values. For example, the decoding process of a monochrome picture with one value of `colour_plane_id` does not use any data from monochrome pictures having different values of `colour_plane_id` for inter prediction.

Depending on the value of `separate_colour_plane_flag`, the value of the variable `ChromaArrayType` is assigned as follows:

- If `separate_colour_plane_flag` is equal to 0, `ChromaArrayType` is set equal to `chroma_format_idc`.
- Otherwise (`separate_colour_plane_flag` is equal to 1), `ChromaArrayType` is set equal to 0.

pic_width_in_luma_samples specifies the width of each decoded picture in units of luma samples. `pic_width_in_luma_samples` shall not be equal to 0 and shall be an integer multiple of `MinCbSizeY`.

pic_height_in_luma_samples specifies the height of each decoded picture in units of luma samples. `pic_height_in_luma_samples` shall not be equal to 0 and shall be an integer multiple of `MinCbSizeY`.

conformance_window_flag equal to 1 indicates that the conformance cropping window offset parameters follow next in the SPS. `conformance_window_flag` equal to 0 indicates that the conformance cropping window offset parameters are not present.

conf_win_left_offset, **conf_win_right_offset**, **conf_win_top_offset**, and **conf_win_bottom_offset** specify the samples of the pictures in the CVS that are output from the decoding process, in terms of a rectangular region specified in picture coordinates for output. When `conformance_window_flag` is equal to 0, the values of `conf_win_left_offset`, `conf_win_right_offset`, `conf_win_top_offset`, and `conf_win_bottom_offset` are inferred to be equal to 0.

The conformance cropping window contains the luma samples with horizontal picture coordinates from `SubWidthC * conf_win_left_offset` to `pic_width_in_luma_samples - (SubWidthC * conf_win_right_offset + 1)` and vertical picture coordinates from `SubHeightC * conf_win_top_offset` to `pic_height_in_luma_samples - (SubHeightC * conf_win_bottom_offset + 1)`, inclusive.

The value of `SubWidthC * (conf_win_left_offset + conf_win_right_offset)` shall be less than `pic_width_in_luma_samples`, and the value of `SubHeightC * (conf_win_top_offset + conf_win_bottom_offset)` shall be less than `pic_height_in_luma_samples`.

When ChromaArrayType is not equal to 0, the corresponding specified samples of the two chroma arrays are the samples having picture coordinates (x / SubWidthC, y / SubHeightC), where (x, y) are the picture coordinates of the specified luma samples.

NOTE 3 The conformance cropping window offset parameters are only applied at the output. All internal decoding processes are applied to the uncropped picture size.

bit_depth_luma_minus8 specifies the bit depth of the samples of the luma array BitDepth_Y and the value of the luma quantization parameter range offset QpBdOffset_Y as follows:

$$\text{BitDepth}_Y = 8 + \text{bit_depth_luma_minus8} \quad (7-4)$$

$$\text{QpBdOffset}_Y = 6 * \text{bit_depth_luma_minus8} \quad (7-5)$$

$\text{bit_depth_luma_minus8}$ shall be in the range of 0 to 8, inclusive.

bit_depth_chroma_minus8 specifies the bit depth of the samples of the chroma arrays BitDepth_C and the value of the chroma quantization parameter range offset QpBdOffset_C as follows:

$$\text{BitDepth}_C = 8 + \text{bit_depth_chroma_minus8} \quad (7-6)$$

$$\text{QpBdOffset}_C = 6 * \text{bit_depth_chroma_minus8} \quad (7-7)$$

$\text{bit_depth_chroma_minus8}$ shall be in the range of 0 to 8, inclusive.

log2_max_pic_order_cnt_lsb_minus4 specifies the value of the variable MaxPicOrderCntLsb that is used in the decoding process for picture order count as follows:

$$\text{MaxPicOrderCntLsb} = 2^{(\text{log2_max_pic_order_cnt_lsb_minus4} + 4)} \quad (7-8)$$

The value of $\text{log2_max_pic_order_cnt_lsb_minus4}$ shall be in the range of 0 to 12, inclusive.

sps_sub_layer_ordering_info_present_flag equal to 1 specifies that $\text{sps_max_dec_pic_buffering_minus1}[i]$, $\text{sps_max_num_reorder_pics}[i]$, and $\text{sps_max_latency_increase_plus1}[i]$ are present for $\text{sps_max_sub_layers_minus1} + 1$ sub-layers. $\text{sps_sub_layer_ordering_info_present_flag}$ equal to 0 specifies that the values of $\text{sps_max_dec_pic_buffering_minus1}[\text{sps_max_sub_layers_minus1}]$, $\text{sps_max_num_reorder_pics}[\text{sps_max_sub_layers_minus1}]$, and $\text{sps_max_latency_increase_plus1}[\text{sps_max_sub_layers_minus1}]$ apply to all sub-layers.

sps_max_dec_pic_buffering_minus1[i] plus 1 specifies the maximum required size of the decoded picture buffer for the CVS in units of picture storage buffers when HighestTid is equal to i. The value of $\text{sps_max_dec_pic_buffering_minus1}[i]$ shall be in the range of 0 to $\text{MaxDpbSize} - 1$, inclusive, where MaxDpbSize is as specified in A.4. When i is greater than 0, $\text{sps_max_dec_pic_buffering_minus1}[i]$ shall be greater than or equal to $\text{sps_max_dec_pic_buffering_minus1}[i - 1]$. The value of $\text{sps_max_dec_pic_buffering_minus1}[i]$ shall be less than or equal to $\text{vps_max_dec_pic_buffering_minus1}[i]$ for each value of i. When $\text{sps_max_dec_pic_buffering_minus1}[i]$ is not present for i in the range of 0 to $\text{sps_max_sub_layers_minus1} - 1$, inclusive, due to $\text{sps_sub_layer_ordering_info_present_flag}$ being equal to 0, it is inferred to be equal to $\text{sps_max_dec_pic_buffering_minus1}[\text{sps_max_sub_layers_minus1}]$.

sps_max_num_reorder_pics[i] indicates the maximum allowed number of pictures with PicOutputFlag equal to 1 that can precede any picture with PicOutputFlag equal to 1 in the CVS in decoding order and follow that picture with PicOutputFlag equal to 1 in output order when HighestTid is equal to i. The value of $\text{sps_max_num_reorder_pics}[i]$ shall be in the range of 0 to $\text{sps_max_dec_pic_buffering_minus1}[i]$, inclusive. When i is greater than 0, $\text{sps_max_num_reorder_pics}[i]$ shall be greater than or equal to $\text{sps_max_num_reorder_pics}[i - 1]$. The value of $\text{sps_max_num_reorder_pics}[i]$ shall be less than or equal to $\text{vps_max_num_reorder_pics}[i]$ for each value of i. When $\text{sps_max_num_reorder_pics}[i]$ is not present for i in the range of 0 to $\text{sps_max_sub_layers_minus1} - 1$, inclusive, due to $\text{sps_sub_layer_ordering_info_present_flag}$ being equal to 0, it is inferred to be equal to $\text{sps_max_num_reorder_pics}[\text{sps_max_sub_layers_minus1}]$.

sps_max_latency_increase_plus1[i] not equal to 0 is used to compute the value of **SpsMaxLatencyPictures**[i], which specifies the maximum number of pictures with **PicOutputFlag** equal to 1 that can precede any picture with **PicOutputFlag** equal to 1 in the CVS in output order and follow that picture with **PicOutputFlag** equal to 1 in decoding order when **HighestTid** is equal to i.

When **sps_max_latency_increase_plus1**[i] is not equal to 0, the value of **SpsMaxLatencyPictures**[i] is specified as follows:

$$\text{SpsMaxLatencyPictures}[i] = \text{sps_max_num_reorder_pics}[i] + \text{sps_max_latency_increase_plus1}[i] - 1 \quad (7-9)$$

When **sps_max_latency_increase_plus1**[i] is equal to 0, no corresponding limit is expressed.

The value of **sps_max_latency_increase_plus1**[i] shall be in the range of 0 to $2^{32} - 2$, inclusive. When **vps_max_latency_increase_plus1**[i] is not equal to 0, the value of **sps_max_latency_increase_plus1**[i] shall not be equal to 0 and shall be less than or equal to **vps_max_latency_increase_plus1**[i] for each value of i. When **sps_max_latency_increase_plus1**[i] is not present for i in the range of 0 to **sps_max_sub_layers_minus1** - 1, inclusive, due to **sps_sub_layer_ordering_info_present_flag** being equal to 0, it is inferred to be equal to **sps_max_latency_increase_plus1**[**sps_max_sub_layers_minus1**].

log2_min_luma_coding_block_size_minus3 plus 3 specifies the minimum luma coding block size.

log2_diff_max_min_luma_coding_block_size specifies the difference between the maximum and minimum luma coding block size.

The variables **MinCbLog2SizeY**, **CtbLog2SizeY**, **MinCbSizeY**, **CtbSizeY**, **PicWidthInMinCbsY**, **PicWidthInCtbsY**, **PicHeightInMinCbsY**, **PicHeightInCtbsY**, **PicSizeInMinCbsY**, **PicSizeInCtbsY**, **PicSizeInSamplesY**, **PicWidthInSamplesC**, and **PicHeightInSamplesC** are derived as follows:

$$\text{MinCbLog2SizeY} = \text{log2_min_luma_coding_block_size_minus3} + 3 \quad (7-10)$$

$$\text{CtbLog2SizeY} = \text{MinCbLog2SizeY} + \text{log2_diff_max_min_luma_coding_block_size} \quad (7-11)$$

$$\text{MinCbSizeY} = 1 \ll \text{MinCbLog2SizeY} \quad (7-12)$$

$$\text{CtbSizeY} = 1 \ll \text{CtbLog2SizeY} \quad (7-13)$$

$$\text{PicWidthInMinCbsY} = \text{pic_width_in_luma_samples} / \text{MinCbSizeY} \quad (7-14)$$

$$\text{PicWidthInCtbsY} = \text{Ceil}(\text{pic_width_in_luma_samples} \div \text{CtbSizeY}) \quad (7-15)$$

$$\text{PicHeightInMinCbsY} = \text{pic_height_in_luma_samples} / \text{MinCbSizeY} \quad (7-16)$$

$$\text{PicHeightInCtbsY} = \text{Ceil}(\text{pic_height_in_luma_samples} \div \text{CtbSizeY}) \quad (7-17)$$

$$\text{PicSizeInMinCbsY} = \text{PicWidthInMinCbsY} * \text{PicHeightInMinCbsY} \quad (7-18)$$

$$\text{PicSizeInCtbsY} = \text{PicWidthInCtbsY} * \text{PicHeightInCtbsY} \quad (7-19)$$

$$\text{PicSizeInSamplesY} = \text{pic_width_in_luma_samples} * \text{pic_height_in_luma_samples} \quad (7-20)$$

$$\text{PicWidthInSamplesC} = \text{pic_width_in_luma_samples} / \text{SubWidthC} \quad (7-21)$$

$$\text{PicHeightInSamplesC} = \text{pic_height_in_luma_samples} / \text{SubHeightC} \quad (7-22)$$

The variables **CtbWidthC** and **CtbHeightC**, which specify the width and height, respectively, of the array for each chroma coding tree block, are derived as follows:

- If **chroma_format_idc** is equal to 0 (monochrome) or **separate_colour_plane_flag** is equal to 1, **CtbWidthC** and **CtbHeightC** are both equal to 0.

ISO/IEC 23008-2:2017(E)

— Otherwise, CtbWidthC and CtbHeightC are derived as follows:

$$\text{CtbWidthC} = \text{CtbSizeY} / \text{SubWidthC} \quad (7-23)$$

$$\text{CtbHeightC} = \text{CtbSizeY} / \text{SubHeightC} \quad (7-24)$$

log2_min_luma_transform_block_size_minus2 plus 2 specifies the minimum luma transform block size.

The variable MinTbLog2SizeY is set equal to log2_min_luma_transform_block_size_minus2 + 2. The CVS shall not contain data that result in MinTbLog2SizeY greater than or equal to MinCbLog2SizeY.

log2_diff_max_min_luma_transform_block_size specifies the difference between the maximum and minimum luma transform block size.

The variable MaxTbLog2SizeY is set equal to log2_min_luma_transform_block_size_minus2 + 2 + log2_diff_max_min_luma_transform_block_size.

The CVS shall not contain data that result in MaxTbLog2SizeY greater than Min(CtbLog2SizeY, 5).

The array ScanOrder[log2BlockSize][scanIdx][sPos][sComp] specifies the mapping of the scan position sPos, ranging from 0 to (1 << log2BlockSize) * (1 << log2BlockSize) - 1, inclusive, to horizontal and vertical components of the scan-order matrix. The array index scanIdx equal to 0 specifies an up-right diagonal scan order, scanIdx equal to 1 specifies a horizontal scan order, scanIdx equal to 2 specifies a vertical scan order, and scanIdx equal to 3 specifies a traverse scan order. The array index sComp equal to 0 specifies the horizontal component and the array index sComp equal to 1 specifies the vertical component. The array ScanOrder is derived as follows.

For the variable log2BlockSize ranging from 0 to 5, inclusive, the scanning order array ScanOrder is derived as follows.

- For log2BlockSize ranging from 0 to 3, inclusive, the up-right diagonal scan order array initialization process as specified in 6.5.3 is invoked with 1 << log2BlockSize as input, and the output is assigned to ScanOrder[log2BlockSize][0].
- For log2BlockSize ranging from 0 to 3, inclusive, the horizontal scan order array initialization process as specified in 6.5.4 is invoked with 1 << log2BlockSize as input, and the output is assigned to ScanOrder[log2BlockSize][1].
- For log2BlockSize ranging from 0 to 3, inclusive, the vertical scan order array initialization process as specified in 6.5.5 is invoked with 1 << log2BlockSize as input, and the output is assigned to ScanOrder[log2BlockSize][2].
- For log2BlockSize ranging from 2 to 5, inclusive, the traverse scan order array initialization process as specified in 6.5.6 is invoked with 1 << log2BlockSize as input, and the output is assigned to ScanOrder[log2BlockSize][3].

max_transform_hierarchy_depth_inter specifies the maximum hierarchy depth for transform units of coding units coded in inter prediction mode. The value of max_transform_hierarchy_depth_inter shall be in the range of 0 to CtbLog2SizeY - MinTbLog2SizeY, inclusive.

max_transform_hierarchy_depth_intra specifies the maximum hierarchy depth for transform units of coding units coded in intra prediction mode. The value of max_transform_hierarchy_depth_intra shall be in the range of 0 to CtbLog2SizeY - MinTbLog2SizeY, inclusive.

scaling_list_enabled_flag equal to 1 specifies that a scaling list is used for the scaling process for transform coefficients. scaling_list_enabled_flag equal to 0 specifies that scaling list is not used for the scaling process for transform coefficients.

sps_scaling_list_data_present_flag equal to 1 specifies that the scaling_list_data() syntax structure is present in the SPS. sps_scaling_list_data_present_flag equal to 0 specifies that the scaling_list_data()

syntax structure is not present in the SPS. When not present, the value of `sps_scaling_list_data_present_flag` is inferred to be equal to 0.

amp_enabled_flag equal to 1 specifies that asymmetric motion partitions, i.e. PartMode equal to PART_2NxN_U, PART_2NxN_D, PART_nLx2N, or PART_nRx2N, may be used in coding tree blocks. `amp_enabled_flag` equal to 0 specifies that asymmetric motion partitions cannot be used in coding tree blocks.

sample_adaptive_offset_enabled_flag equal to 1 specifies that the sample adaptive offset process is applied to the reconstructed picture after the deblocking filter process. `sample_adaptive_offset_enabled_flag` equal to 0 specifies that the sample adaptive offset process is not applied to the reconstructed picture after the deblocking filter process.

pcm_enabled_flag equal to 0 specifies that PCM-related syntax (`pcm_sample_bit_depth_luma_minus1`, `pcm_sample_bit_depth_chroma_minus1`, `log2_min_pcm_luma_coding_block_size_minus3`, `log2_diff_max_min_pcm_luma_coding_block_size`, `pcm_loop_filter_disabled_flag`, `pcm_flag`, `pcm_alignment_zero_bit` syntax elements and `pcm_sample()` syntax structure) is not present in the CVS.

NOTE 4 When `MinCbLog2SizeY` is equal to 6 and `pcm_enabled_flag` is equal to 1, PCM sample data-related syntax (`pcm_flag`, `pcm_alignment_zero_bit` syntax elements and `pcm_sample()` syntax structure) is not present in the CVS, because the maximum size of coding blocks that can convey PCM sample data-related syntax is restricted to be less than or equal to $\text{Min}(\text{CtbLog2SizeY}, 5)$. Hence, `MinCbLog2SizeY` equal to 6 with `pcm_enabled_flag` equal to 1 is not an appropriate setting to convey PCM sample data in the CVS.

pcm_sample_bit_depth_luma_minus1 specifies the number of bits used to represent each of PCM sample values of the luma component as follows:

$$\text{PcmBitDepth}_Y = \text{pcm_sample_bit_depth_luma_minus1} + 1 \quad (7-25)$$

The value of `PcmBitDepthY` shall be less than or equal to the value of `BitDepthY`.

pcm_sample_bit_depth_chroma_minus1 specifies the number of bits used to represent each of PCM sample values of the chroma components as follows:

$$\text{PcmBitDepth}_C = \text{pcm_sample_bit_depth_chroma_minus1} + 1 \quad (7-26)$$

The value of `PcmBitDepthC` shall be less than or equal to the value of `BitDepthC`. When `ChromaArrayType` is equal to 0, `pcm_sample_bit_depth_chroma_minus1` is not used in the decoding process and decoders shall ignore its value.

log2_min_pcm_luma_coding_block_size_minus3 plus 3 specifies the minimum size of coding blocks with `pcm_flag` equal to 1.

The variable `Log2MinIpcmCbSizeY` is set equal to `log2_min_pcm_luma_coding_block_size_minus3` + 3. The value of `Log2MinIpcmCbSizeY` shall be in the range of $\text{Min}(\text{MinCbLog2SizeY}, 5)$ to $\text{Min}(\text{CtbLog2SizeY}, 5)$, inclusive.

log2_diff_max_min_pcm_luma_coding_block_size specifies the difference between the maximum and minimum size of coding blocks with `pcm_flag` equal to 1.

The variable `Log2MaxIpcmCbSizeY` is set equal to `log2_diff_max_min_pcm_luma_coding_block_size` + `Log2MinIpcmCbSizeY`. The value of `Log2MaxIpcmCbSizeY` shall be less than or equal to $\text{Min}(\text{CtbLog2SizeY}, 5)$.

pcm_loop_filter_disabled_flag specifies whether the loop filter process is disabled on reconstructed samples in a coding unit with `pcm_flag` equal to 1 as follows:

- If `pcm_loop_filter_disabled_flag` is equal to 1, the deblocking filter and sample adaptive offset filter processes on the reconstructed samples in a coding unit with `pcm_flag` equal to 1 are disabled.

ISO/IEC 23008-2:2017(E)

- Otherwise (`pcm_loop_filter_disabled_flag` value is equal to 0), the deblocking filter and sample adaptive offset filter processes on the reconstructed samples in a coding unit with `pcm_flag` equal to 1 are not disabled.

When `pcm_loop_filter_disabled_flag` is not present, it is inferred to be equal to 0.

num_short_term_ref_pic_sets specifies the number of `st_ref_pic_set()` syntax structures included in the SPS. The value of `num_short_term_ref_pic_sets` shall be in the range of 0 to 64, inclusive.

NOTE 5 A decoder is expected to allocate memory for a total number of `num_short_term_ref_pic_sets` + 1 `st_ref_pic_set()` syntax structures since there can be a `st_ref_pic_set()` syntax structure directly signalled in the slice headers of a current picture. A `st_ref_pic_set()` syntax structure directly signalled in the slice headers of a current picture has an index equal to `num_short_term_ref_pic_sets`.

long_term_ref_pics_present_flag equal to 0 specifies that no long-term reference picture is used for inter prediction of any coded picture in the CVS. **long_term_ref_pics_present_flag** equal to 1 specifies that long-term reference pictures may be used for inter prediction of one or more coded pictures in the CVS.

num_long_term_ref_pics_sps specifies the number of candidate long-term reference pictures that are specified in the SPS. The value of `num_long_term_ref_pics_sps` shall be in the range of 0 to 32, inclusive.

lt_ref_pic_poc_lsb_sps[*i*] specifies the picture order count modulo `MaxPicOrderCntLsb` of the *i*-th candidate long-term reference picture specified in the SPS. The number of bits used to represent `lt_ref_pic_poc_lsb_sps`[*i*] is equal to $\log_2_{\text{max_pic_order_cnt_lsb_minus4}} + 4$.

used_by_curr_pic_lt_sps_flag[*i*] equal to 0 specifies that the *i*-th candidate long-term reference picture specified in the SPS is not used for reference by a picture that includes in its long-term RPS the *i*-th candidate long-term reference picture specified in the SPS.

sps_temporal_mvp_enabled_flag equal to 1 specifies that `slice_temporal_mvp_enabled_flag` is present in the slice headers of non-IDR pictures in the CVS. **sps_temporal_mvp_enabled_flag** equal to 0 specifies that `slice_temporal_mvp_enabled_flag` is not present in slice headers and that temporal motion vector predictors are not used in the CVS.

strong_intra_smoothing_enabled_flag equal to 1 specifies that bi-linear interpolation is conditionally used in the intra prediction filtering process in the CVS as specified in 8.4.4.2.3. **strong_intra_smoothing_enabled_flag** equal to 0 specifies that the bi-linear interpolation is not used in the CVS.

vui_parameters_present_flag equal to 1 specifies that the `vui_parameters()` syntax structure as specified in Annex E is present. **vui_parameters_present_flag** equal to 0 specifies that the `vui_parameters()` syntax structure as specified in Annex E is not present.

sps_extension_present_flag equal to 1 specifies that the syntax elements `sps_range_extension_flag`, `sps_multilayer_extension_flag`, `sps_3d_extension_flag`, `sps_scc_extension_flag`, and `sps_extension_4bits` are present in the SPS RBSP syntax structure. **sps_extension_present_flag** equal to 0 specifies that these syntax elements are not present.

sps_range_extension_flag equal to 1 specifies that the `sps_range_extension()` syntax structure is present in the SPS RBSP syntax structure. **sps_range_extension_flag** equal to 0 specifies that this syntax structure is not present. When not present, the value of `sps_range_extension_flag` is inferred to be equal to 0.

sps_multilayer_extension_flag equal to 1 specifies that the `sps_multilayer_extension()` syntax structure (specified in Annex F) is present in the SPS RBSP syntax structure. **sps_multilayer_extension_flag** equal to 0 specifies that the `sps_multilayer_extension()` syntax structure is not present. When not present, the value of `sps_multilayer_extension_flag` is inferred to be equal to 0.

sps_3d_extension_flag equal to 1 specifies that the `sps_3d_extension()` syntax structure (specified in Annex I) is present in the SPS RBSP syntax structure. **sps_3d_extension_flag** equal to 0 specifies that the

`sps_3d_extension()` syntax structure is not present. When not present, the value of `sps_3d_extension_flag` is inferred to be equal to 0.

`sps_scc_extension_flag` equal to 1 specifies that the `sps_scc_extension()` syntax structure is present in the SPS RBSP syntax structure. `sps_scc_extension_flag` equal to 0 specifies that this syntax structure is not present. When not present, the value of `sps_scc_extension_flag` is inferred to be equal to 0.

`sps_extension_4bits` equal to 0 specifies that no `sps_extension_data_flag` syntax elements are present in the SPS RBSP syntax structure. When present, `sps_extension_4bits` shall be equal to 0 in bitstreams conforming to this version of this document. Values of `sps_extension_4bits` not equal to 0 are reserved for future use by ITU-T | ISO/IEC. Decoders shall allow the value of `sps_extension_4bits` to be not equal to 0 and shall ignore all `sps_extension_data_flag` syntax elements in an SPS NAL unit. When not present, the value of `sps_extension_4bits` is inferred to be equal to 0.

`sps_extension_data_flag` may have any value. Its presence and value do not affect decoder conformance to profiles specified in this version of this document. Decoders conforming to this version of this document shall ignore all `sps_extension_data_flag` syntax elements.

7.4.3.2.2 Sequence parameter set range extension semantics

`transform_skip_rotation_enabled_flag` equal to 1 specifies that a rotation is applied to the residual data block for intra 4x4 blocks coded using a transform skip operation. `transform_skip_rotation_enabled_flag` equal to 0 specifies that this rotation is not applied. When not present, the value of `transform_skip_rotation_enabled_flag` is inferred to be equal to 0.

`transform_skip_context_enabled_flag` equal to 1 specifies that a particular context is used for the parsing of the `sig_coeff_flag` for transform blocks with a skipped transform. `transform_skip_context_enabled_flag` equal to 0 specifies that the presence or absence of transform skipping or a transform bypass for transform blocks is not used in the context selection for this flag. When not present, the value of `transform_skip_context_enabled_flag` is inferred to be equal to 0.

`implicit_rdpcm_enabled_flag` equal to 1 specifies that the residual modification process for blocks using a transform bypass may be used for intra blocks in the CVS. `implicit_rdpcm_enabled_flag` equal to 0 specifies that the residual modification process is not used for intra blocks in the CVS. When not present, the value of `implicit_rdpcm_enabled_flag` is inferred to be equal to 0.

`explicit_rdpcm_enabled_flag` equal to 1 specifies that the residual modification process for blocks using a transform bypass may be used for inter blocks in the CVS. `explicit_rdpcm_enabled_flag` equal to 0 specifies that the residual modification process is not used for inter blocks in the CVS. When not present, the value of `explicit_rdpcm_enabled_flag` is inferred to be equal to 0.

`extended_precision_processing_flag` equal to 1 specifies that an extended dynamic range is used for coefficient parsing and inverse transform processing. `extended_precision_processing_flag` equal to 0 specifies that the extended dynamic range is not used. When not present, the value of `extended_precision_processing_flag` is inferred to be equal to 0.

The variables `CoeffMinY`, `CoeffMinC`, `CoeffMaxY`, and `CoeffMaxC` are derived as follows:

$$\text{CoeffMin}_Y = -(1 \ll (\text{extended_precision_processing_flag} ? \text{Max}(15, \text{BitDepth}_Y + 6) : 15)) \quad (7-27)$$

$$\text{CoeffMin}_C = -(1 \ll (\text{extended_precision_processing_flag} ? \text{Max}(15, \text{BitDepth}_C + 6) : 15)) \quad (7-28)$$

$$\text{CoeffMax}_Y = (1 \ll (\text{extended_precision_processing_flag} ? \text{Max}(15, \text{BitDepth}_Y + 6) : 15)) - 1 \quad (7-29)$$

$$\text{CoeffMax}_C = (1 \ll (\text{extended_precision_processing_flag} ? \text{Max}(15, \text{BitDepth}_C + 6) : 15)) - 1 \quad (7-30)$$

`intra_smoothing_disabled_flag` equal to 1 specifies that the filtering process of neighbouring samples is unconditionally disabled for intra prediction. `intra_smoothing_disabled_flag` equal to 0 specifies that the filtering process of neighbouring samples is not disabled. When not present, the value of `intra_smoothing_disabled_flag` is inferred to be equal to 0.

high_precision_offsets_enabled_flag equal to 1 specifies that weighted prediction offset values are signalled using a bit-depth-dependent precision. **high_precision_offsets_enabled_flag** equal to 0 specifies that weighted prediction offset values are signalled with a precision equivalent to eight bit processing.

The variables $WpOffsetBdShift_Y$, $WpOffsetBdShift_C$, $WpOffsetHalfRange_Y$, and $WpOffsetHalfRange_C$ are derived as follows:

$$WpOffsetBdShift_Y = \text{high_precision_offsets_enabled_flag} ? 0 : (\text{BitDepth}_Y - 8) \quad (7-31)$$

$$WpOffsetBdShift_C = \text{high_precision_offsets_enabled_flag} ? 0 : (\text{BitDepth}_C - 8) \quad (7-32)$$

$$WpOffsetHalfRange_Y = 1 \ll (\text{high_precision_offsets_enabled_flag} ? (\text{BitDepth}_Y - 1) : 7) \quad (7-33)$$

$$WpOffsetHalfRange_C = 1 \ll (\text{high_precision_offsets_enabled_flag} ? (\text{BitDepth}_C - 1) : 7) \quad (7-34)$$

persistent_rice_adaptation_enabled_flag equal to 1 specifies that the Rice parameter derivation for the binarization of `coeff_abs_level_remaining[]` is initialized at the start of each sub-block using mode dependent statistics accumulated from previous sub-blocks. **persistent_rice_adaptation_enabled_flag** equal to 0 specifies that no previous sub-block state is used in Rice parameter derivation. When not present, the value of **persistent_rice_adaptation_enabled_flag** is inferred to be equal to 0.

cabac_bypass_alignment_enabled_flag equal to 1 specifies that a CABAC alignment process is used prior to bypass decoding of the syntax elements `coeff_sign_flag[]` and `coeff_abs_level_remaining[]`. **cabac_bypass_alignment_enabled_flag** equal to 0 specifies that no CABAC alignment process is used prior to bypass decoding. When not present, the value of **cabac_bypass_alignment_enabled_flag** is inferred to be equal to 0.

7.4.3.2.3 Sequence parameter set screen content coding extension semantics

sps_curr_pic_ref_enabled_flag equal to 1 specifies that a picture in the CVS may be included in a reference picture list of a slice of the picture itself. **sps_curr_pic_ref_enabled_flag** equal to 0 specifies that a picture in the CVS is never included in a reference picture list of a slice of the picture itself. When not present, the value of **sps_curr_pic_ref_enabled_flag** is inferred to be equal to 0.

palette_mode_enabled_flag equal to 1 specifies that the decoding process for palette mode may be used for intra blocks. **palette_mode_enabled_flag** equal to 0 specifies that the decoding process for palette mode is not applied. When not present, the value of **palette_mode_enabled_flag** is inferred to be equal to 0.

palette_max_size specifies the maximum allowed palette size. When not present, the value of **palette_max_size** is inferred to be 0.

delta_palette_max_predictor_size specifies the difference between the maximum allowed palette predictor size and the maximum allowed palette size. When not present, the value of **delta_palette_max_predictor_size** is inferred to be 0. The variable `PaletteMaxPredictorSize` is derived as follows:

$$\text{PaletteMaxPredictorSize} = \text{palette_max_size} + \text{delta_palette_max_predictor_size} \quad (7-35)$$

It is a requirement of bitstream conformance that the value of **delta_palette_max_predictor_size** shall be equal to 0 when **palette_max_size** is equal to 0.

sps_palette_predictor_initializer_present_flag equal to 1 specifies that the sequence palette predictors are initialized using the `sps_palette_predictor_initializers`. **sps_palette_predictor_initializer_present_flag** equal to 0 specifies that the entries in the sequence palette predictor are initialized to 0. When not present, the value of **sps_palette_predictor_initializer_present_flag** is inferred to be equal to 0.

It is a requirement of bitstream conformance that the value of **sps_palette_predictor_initializer_present_flag** shall be equal to 0 when **palette_max_size** is equal to 0.

sps_num_palette_predictor_initializer_minus1 plus 1 specifies the number of entries in the sequence palette predictor initializer.

It is a requirement of bitstream conformance that the value of **sps_num_palette_predictor_initializer_minus1** plus 1 shall be less than or equal to **PaletteMaxPredictorSize**.

sps_palette_predictor_initializers[comp][i] specifies the value of the comp-th component of the i-th palette entry in the SPS that is used to initialize the array **PredictorPaletteEntries**. For values of i in the range of 0 to **sps_num_palette_predictor_initializer_minus1**, inclusive, the value of the **sps_palette_predictor_initializers**[0][i] shall be in the range of 0 to $(1 \ll \text{BitDepth}_v) - 1$, inclusive, and the values of **sps_palette_predictor_initializers**[1][i] and **sps_palette_predictor_initializers**[2][i] shall be in the range of 0 to $(1 \ll \text{BitDepth}_c) - 1$, inclusive.

motion_vector_resolution_control_idc controls the presence and inference of the **use_integer_mv_flag** that specifies the resolution of motion vectors for inter prediction. The value of **motion_vector_resolution_control_idc** shall not be equal to 3 in bitstreams conforming to this version of this document. The value of 3 for **motion_vector_resolution_control_idc** is reserved for future use by ITU-T | ISO/IEC. When not present, the value of **motion_vector_resolution_control_idc** is inferred to be equal to 0.

intra_boundary_filtering_disabled_flag equal to 1 specifies that the intra boundary filtering process is unconditionally disabled for intra prediction. **intra_boundary_filtering_disabled_flag** equal to 0 specifies that the intra boundary filtering process may be used. When not present, the value of **intra_boundary_filtering_disabled_flag** is inferred to be equal to 0.

7.4.3.3 Picture parameter set RBSP semantics

7.4.3.3.1 General picture parameter set RBSP semantics

pps_pic_parameter_set_id identifies the PPS for reference by other syntax elements. The value of **pps_pic_parameter_set_id** shall be in the range of 0 to 63, inclusive.

pps_seq_parameter_set_id specifies the value of **sps_seq_parameter_set_id** for the active SPS. The value of **pps_seq_parameter_set_id** shall be in the range of 0 to 15, inclusive.

dependent_slice_segments_enabled_flag equal to 1 specifies the presence of the syntax element **dependent_slice_segment_flag** in the slice segment headers for coded pictures referring to the PPS. **dependent_slice_segments_enabled_flag** equal to 0 specifies the absence of the syntax element **dependent_slice_segment_flag** in the slice segment headers for coded pictures referring to the PPS.

output_flag_present_flag equal to 1 indicates that the **pic_output_flag** syntax element is present in the associated slice headers. **output_flag_present_flag** equal to 0 indicates that the **pic_output_flag** syntax element is not present in the associated slice headers.

num_extra_slice_header_bits specifies the number of extra slice header bits that are present in the slice header RBSP for coded pictures referring to the PPS. The value of **num_extra_slice_header_bits** shall be in the range of 0 to 2, inclusive, in bitstreams conforming to this version of this document. Other values for **num_extra_slice_header_bits** are reserved for future use by ITU-T | ISO/IEC. However, decoders shall allow **num_extra_slice_header_bits** to have any value.

sign_data_hiding_enabled_flag equal to 0 specifies that sign bit hiding is disabled. **sign_data_hiding_enabled_flag** equal to 1 specifies that sign bit hiding is enabled.

cabac_init_present_flag equal to 1 specifies that **cabac_init_flag** is present in slice headers referring to the PPS. **cabac_init_present_flag** equal to 0 specifies that **cabac_init_flag** is not present in slice headers referring to the PPS.

num_ref_idx_l0_default_active_minus1 specifies the inferred value of **num_ref_idx_l0_active_minus1** for P and B slices with **num_ref_idx_active_override_flag** equal to 0. The value of **num_ref_idx_l0_default_active_minus1** shall be in the range of 0 to 14, inclusive.

num_ref_idx_l1_default_active_minus1 specifies the inferred value of num_ref_idx_l1_active_minus1 with num_ref_idx_active_override_flag equal to 0. The value of num_ref_idx_l1_default_active_minus1 shall be in the range of 0 to 14, inclusive.

init_qp_minus26 plus 26 specifies the initial value of SliceQp_Y for each slice referring to the PPS. The initial value of SliceQp_Y is modified at the slice segment layer when a non-zero value of slice_qp_delta is decoded. The value of init_qp_minus26 shall be in the range of $-(26 + QpBdOffset_Y)$ to +25, inclusive.

constrained_intra_pred_flag equal to 0 specifies that intra prediction allows usage of residual data and decoded samples of neighbouring coding blocks coded using intra or inter prediction modes. constrained_intra_pred_flag equal to 1 specifies constrained intra prediction, in which case intra prediction only uses residual data and decoded samples from neighbouring coding blocks coded using intra prediction modes.

NOTE 1 Encoders that operate in error-prone environments should be designed with consideration of the potential for error propagation caused by references to other pictures and references to areas within the current picture that use other pictures as references.

transform_skip_enabled_flag equal to 1 specifies that transform_skip_flag may be present in the residual coding syntax. transform_skip_enabled_flag equal to 0 specifies that transform_skip_flag is not present in the residual coding syntax.

cu_qp_delta_enabled_flag equal to 1 specifies that the diff_cu_qp_delta_depth syntax element is present in the PPS and that cu_qp_delta_abs may be present in the transform unit syntax and the palette syntax. cu_qp_delta_enabled_flag equal to 0 specifies that the diff_cu_qp_delta_depth syntax element is not present in the PPS and that cu_qp_delta_abs is not present in the transform unit syntax and the palette syntax.

diff_cu_qp_delta_depth specifies the difference between the luma coding tree block size and the minimum luma coding block size of coding units that convey cu_qp_delta_abs and cu_qp_delta_sign_flag. The value of diff_cu_qp_delta_depth shall be in the range of 0 to log₂diff_max_min_luma_coding_block_size, inclusive. When not present, the value of diff_cu_qp_delta_depth is inferred to be equal to 0.

The variable Log2MinCuQpDeltaSize is derived as follows:

$$\text{Log2MinCuQpDeltaSize} = \text{CtbLog2SizeY} - \text{diff_cu_qp_delta_depth} \quad (7-36)$$

pps_cb_qp_offset and **pps_cr_qp_offset** specify the offsets to the luma quantization parameter Qp'_Y used for deriving Qp'_{cb} and Qp'_{cr}, respectively. The values of pps_cb_qp_offset and pps_cr_qp_offset shall be in the range of -12 to +12, inclusive. When ChromaArrayType is equal to 0, pps_cb_qp_offset and pps_cr_qp_offset are not used in the decoding process and decoders shall ignore their value.

pps_slice_chroma_qp_offsets_present_flag equal to 1 indicates that the slice_cb_qp_offset and slice_cr_qp_offset syntax elements are present in the associated slice headers. pps_slice_chroma_qp_offsets_present_flag equal to 0 indicates that these syntax elements are not present in the associated slice headers. When ChromaArrayType is equal to 0, pps_slice_chroma_qp_offsets_present_flag shall be equal to 0.

weighted_pred_flag equal to 0 specifies that weighted prediction is not applied to P slices. weighted_pred_flag equal to 1 specifies that weighted prediction is applied to P slices.

weighted_bipred_flag equal to 0 specifies that the default weighted prediction is applied to B slices. weighted_bipred_flag equal to 1 specifies that weighted prediction is applied to B slices.

transquant_bypass_enabled_flag equal to 1 specifies that cu_transquant_bypass_flag is present. transquant_bypass_enabled_flag equal to 0 specifies that cu_transquant_bypass_flag is not present.

tiles_enabled_flag equal to 1 specifies that there is more than one tile in each picture referring to the PPS. tiles_enabled_flag equal to 0 specifies that there is only one tile in each picture referring to the PPS.

It is a requirement of bitstream conformance that the value of `tiles_enabled_flag` shall be the same for all PPSs that are activated within a CVS.

entropy_coding_sync_enabled_flag equal to 1 specifies that a specific synchronization process for context variables, and when applicable, Rice parameter initialization states and palette predictor variables, is invoked before decoding the coding tree unit which includes the first coding tree block of a row of coding tree blocks in each tile in each picture referring to the PPS, and a specific storage process for context variables, and when applicable, Rice parameter initialization states and palette predictor variables, is invoked after decoding the coding tree unit which includes the second coding tree block of a row of coding tree blocks in each tile in each picture referring to the PPS. `entropy_coding_sync_enabled_flag` equal to 0 specifies that no specific synchronization process for context variables, and when applicable, Rice parameter initialization states and palette predictor variables, is required to be invoked before decoding the coding tree unit which includes the first coding tree block of a row of coding tree blocks in each tile in each picture referring to the PPS, and no specific storage process for context variables, and when applicable, Rice parameter initialization states and palette predictor variables, is required to be invoked after decoding the coding tree unit which includes the second coding tree block of a row of coding tree blocks in each tile in each picture referring to the PPS.

It is a requirement of bitstream conformance that the value of `entropy_coding_sync_enabled_flag` shall be the same for all PPSs that are activated within a CVS.

When `entropy_coding_sync_enabled_flag` is equal to 1 and the first coding tree block in a slice is not the first coding tree block of a row of coding tree blocks in a tile, it is a requirement of bitstream conformance that the last coding tree block in the slice shall belong to the same row of coding tree blocks as the first coding tree block in the slice.

When `entropy_coding_sync_enabled_flag` is equal to 1 and the first coding tree block in a slice segment is not the first coding tree block of a row of coding tree blocks in a tile, it is a requirement of bitstream conformance that the last coding tree block in the slice segment shall belong to the same row of coding tree blocks as the first coding tree block in the slice segment.

num_tile_columns_minus1 plus 1 specifies the number of tile columns partitioning the picture. `num_tile_columns_minus1` shall be in the range of 0 to $\text{PicWidthInCtbsY} - 1$, inclusive. When not present, the value of `num_tile_columns_minus1` is inferred to be equal to 0.

num_tile_rows_minus1 plus 1 specifies the number of tile rows partitioning the picture. `num_tile_rows_minus1` shall be in the range of 0 to $\text{PicHeightInCtbsY} - 1$, inclusive. When not present, the value of `num_tile_rows_minus1` is inferred to be equal to 0.

When `tiles_enabled_flag` is equal to 1, `num_tile_columns_minus1` and `num_tile_rows_minus1` shall not be both equal to 0.

uniform_spacing_flag equal to 1 specifies that tile column boundaries and likewise tile row boundaries are distributed uniformly across the picture. `uniform_spacing_flag` equal to 0 specifies that tile column boundaries and likewise tile row boundaries are not distributed uniformly across the picture but signalled explicitly using the syntax elements `column_width_minus1[i]` and `row_height_minus1[i]`. When not present, the value of `uniform_spacing_flag` is inferred to be equal to 1.

column_width_minus1[i] plus 1 specifies the width of the *i*-th tile column in units of coding tree blocks.

row_height_minus1[i] plus 1 specifies the height of the *i*-th tile row in units of coding tree blocks.

The following variables are derived by invoking the coding tree block raster and tile scanning conversion process as specified in 6.5.1:

- the list `CtbAddrRsToTs[ctbAddrRs]` for `ctbAddrRs` ranging from 0 to $\text{PicSizeInCtbsY} - 1$, inclusive, specifying the conversion from a CTB address in CTB raster scan of a picture to a CTB address in tile scan;

ISO/IEC 23008-2:2017(E)

- the list `CtbAddrTsToRs[ctbAddrTs]` for `ctbAddrTs` ranging from 0 to `PicSizeInCtbsY - 1`, inclusive, specifying the conversion from a CTB address in tile scan to a CTB address in CTB raster scan of a picture;
- the list `TileId[ctbAddrTs]` for `ctbAddrTs` ranging from 0 to `PicSizeInCtbsY - 1`, inclusive, specifying the conversion from a CTB address in tile scan to a tile ID;
- the list `ColumnWidthInLumaSamples[i]` for `i` ranging from 0 to `num_tile_columns_minus1`, inclusive, specifying the width of the `i`-th tile column in units of luma samples;
- the list `RowHeightInLumaSamples[j]` for `j` ranging from 0 to `num_tile_rows_minus1`, inclusive, specifying the height of the `j`-th tile row in units of luma samples.

The values of `ColumnWidthInLumaSamples[i]` for `i` ranging from 0 to `num_tile_columns_minus1`, inclusive, and `RowHeightInLumaSamples[j]` for `j` ranging from 0 to `num_tile_rows_minus1`, inclusive, shall all be greater than 0.

The array `MinTbAddrZs` with elements `MinTbAddrZs[x][y]` for `x` ranging from 0 to $(\text{PicWidthInCtbsY} \ll (\text{CtbLog2SizeY} - \text{MinTbLog2SizeY})) - 1$, inclusive, and `y` ranging from 0 to $(\text{PicHeightInCtbsY} \ll (\text{CtbLog2SizeY} - \text{MinTbLog2SizeY})) - 1$, inclusive, specifying the conversion from a location (x, y) in units of minimum transform blocks to a transform block address in z-scan order, is derived by invoking the z-scan order array initialization process as specified in 6.5.2.

loop_filter_across_tiles_enabled_flag equal to 1 specifies that in-loop filtering operations may be performed across tile boundaries in pictures referring to the PPS. **loop_filter_across_tiles_enabled_flag** equal to 0 specifies that in-loop filtering operations are not performed across tile boundaries in pictures referring to the PPS. The in-loop filtering operations include the deblocking filter and sample adaptive offset filter operations. When not present, the value of **loop_filter_across_tiles_enabled_flag** is inferred to be equal to 1.

pps_loop_filter_across_slices_enabled_flag equal to 1 specifies that in-loop filtering operations may be performed across left and upper boundaries of slices referring to the PPS. **pps_loop_filter_across_slices_enabled_flag** equal to 0 specifies that in-loop filtering operations are not performed across left and upper boundaries of slices referring to the PPS. The in-loop filtering operations include the deblocking filter and sample adaptive offset filter operations.

NOTE 2 Loop filtering across slice boundaries can be enabled while loop filtering across tile boundaries is disabled and vice versa.

deblocking_filter_control_present_flag equal to 1 specifies the presence of deblocking filter control syntax elements in the PPS. **deblocking_filter_control_present_flag** equal to 0 specifies the absence of deblocking filter control syntax elements in the PPS.

deblocking_filter_override_enabled_flag equal to 1 specifies the presence of **deblocking_filter_override_flag** in the slice headers for pictures referring to the PPS. **deblocking_filter_override_enabled_flag** equal to 0 specifies the absence of **deblocking_filter_override_flag** in the slice headers for pictures referring to the PPS. When not present, the value of **deblocking_filter_override_enabled_flag** is inferred to be equal to 0.

pps_deblocking_filter_disabled_flag equal to 1 specifies that the operation of deblocking filter is not applied for slices referring to the PPS in which **slice_deblocking_filter_disabled_flag** is not present. **pps_deblocking_filter_disabled_flag** equal to 0 specifies that the operation of the deblocking filter is applied for slices referring to the PPS in which **slice_deblocking_filter_disabled_flag** is not present. When not present, the value of **pps_deblocking_filter_disabled_flag** is inferred to be equal to 0.

pps_beta_offset_div2 and **pps_tc_offset_div2** specify the default deblocking parameter offsets for β and tC (divided by 2) that are applied for slices referring to the PPS, unless the default deblocking parameter offsets are overridden by the deblocking parameter offsets present in the slice headers of the slices referring to the PPS. The values of **pps_beta_offset_div2** and **pps_tc_offset_div2** shall both be in

the range of -6 to 6 , inclusive. When not present, the value of `pps_beta_offset_div2` and `pps_tc_offset_div2` are inferred to be equal to 0 .

pps_scaling_list_data_present_flag equal to 1 specifies that the scaling list data used for the pictures referring to the PPS are derived based on the scaling lists specified by the active SPS and the scaling lists specified by the PPS. `pps_scaling_list_data_present_flag` equal to 0 specifies that the scaling list data used for the pictures referring to the PPS are inferred to be equal to those specified by the active SPS. When `scaling_list_enabled_flag` is equal to 0 , the value of `pps_scaling_list_data_present_flag` shall be equal to 0 . When `scaling_list_enabled_flag` is equal to 1 , `sps_scaling_list_data_present_flag` is equal to 0 , and `pps_scaling_list_data_present_flag` is equal to 0 , the default scaling list data are used to derive the array `ScalingFactor` as described in the scaling list data semantics as specified in 7.4.5.

lists_modification_present_flag equal to 1 specifies that the syntax structure `ref_pic_lists_modification()` is present in the slice segment header. `lists_modification_present_flag` equal to 0 specifies that the syntax structure `ref_pic_lists_modification()` is not present in the slice segment header.

log2_parallel_merge_level_minus2 plus 2 specifies the value of the variable `Log2ParMrgLevel`, which is used in the derivation process for luma motion vectors for merge mode as specified in 8.5.3.2.2 and the derivation process for spatial merging candidates as specified in 8.5.3.2.3. The value of `log2_parallel_merge_level_minus2` shall be in the range of 0 to $CtbLog2SizeY - 2$, inclusive.

The variable `Log2ParMrgLevel` is derived as follows:

$$\text{Log2ParMrgLevel} = \text{log2_parallel_merge_level_minus2} + 2 \quad (7-37)$$

NOTE 3 The value of `Log2ParMrgLevel` indicates the built-in capability of parallel derivation of the merging candidate lists. For example, when `Log2ParMrgLevel` is equal to 6 , the merging candidate lists for all the PUs and CUs contained in a 64×64 block can be derived in parallel.

slice_segment_header_extension_present_flag equal to 0 specifies that no slice segment header extension syntax elements are present in the slice segment headers for coded pictures referring to the PPS. `slice_segment_header_extension_present_flag` equal to 1 specifies that slice segment header extension syntax elements are present in the slice segment headers for coded pictures referring to the PPS.

pps_extension_present_flag equal to 1 specifies that the syntax elements `pps_range_extension_flag`, `pps_multilayer_extension_flag`, `pps_3d_extension_flag`, `pps_scc_extension_flag`, and `pps_extension_4bits` are present in the picture parameter set RBSP syntax structure. `pps_extension_present_flag` equal to 0 specifies that these syntax elements are not present.

pps_range_extension_flag equal to 1 specifies that the `pps_range_extension()` syntax structure is present in the PPS RBSP syntax structure. `pps_range_extension_flag` equal to 0 specifies that this syntax structure is not present. When not present, the value of `pps_range_extension_flag` is inferred to be equal to 0 .

pps_multilayer_extension_flag equal to 1 specifies that the `pps_multilayer_extension()` syntax structure is present in the PPS RBSP syntax structure. `pps_multilayer_extension_flag` equal to 0 specifies that the `pps_multilayer_extension()` syntax structure is not present. When not present, the value of `pps_multilayer_extension_flag` is inferred to be equal to 0 .

pps_3d_extension_flag equal to 1 specifies that the `pps_3d_extension()` syntax structure (specified in Annex I) is present in the PPS RBSP syntax structure. `pps_3d_extension_flag` equal to 0 specifies that the `pps_3d_extension()` syntax structure is not present. When not present, the value of `pps_3d_extension_flag` is inferred to be equal to 0 .

pps_scc_extension_flag equal to 1 specifies that the `pps_scc_extension()` syntax structure is present in the PPS RBSP syntax structure. `pps_scc_extension_flag` equal to 0 specifies that this syntax structure is not present. When not present, the value of `pps_scc_extension_flag` is inferred to be equal to 0 .

pps_extension_4bits equal to 0 specifies that no **pps_extension_data_flag** syntax elements are present in the PPS Rbsp syntax structure. When present, **pps_extension_4bits** shall be equal to 0 in bitstreams conforming to this version of this document. Values of **pps_extension_4bits** not equal to 0 are reserved for future use by ITU-T | ISO/IEC. Decoders shall allow the value of **pps_extension_4bits** to be not equal to 0 and shall ignore all **pps_extension_data_flag** syntax elements in a PPS NAL unit. When not present, the value of **pps_extension_4bits** is inferred to be equal to 0.

pps_extension_data_flag may have any value. Its presence and value do not affect decoder conformance to profiles specified in this version of this document. Decoders conforming to this version of this document shall ignore all **pps_extension_data_flag** syntax elements.

7.4.3.3.2 Picture parameter set range extension semantics

log2_max_transform_skip_block_size_minus2 plus 2 specifies the maximum transform block size for which **transform_skip_flag** may be present in coded pictures referring to the PPS. When not present, the value of **log2_max_transform_skip_block_size_minus2** is inferred to be equal to 0. When present, the value of **log2_max_transform_skip_block_size_minus2** shall be less than or equal to $\text{MaxTbLog2SizeY} - 2$.

The variable **Log2MaxTransformSkipSize** is derived as follows:

$$\text{Log2MaxTransformSkipSize} = \text{log2_max_transform_skip_block_size_minus2} + 2 \quad (7-38)$$

cross_component_prediction_enabled_flag equal to 1 specifies that **log2_res_scale_abs_plus1** and **res_scale_sign_flag** may be present in the transform unit syntax for pictures referring to the PPS. **cross_component_prediction_enabled_flag** equal to 0 specifies that **log2_res_scale_abs_plus1** and **res_scale_sign_flag** are not present for pictures referring to the PPS. When not present, the value of **cross_component_prediction_enabled_flag** is inferred to be equal to 0. When **ChromaArrayType** is not equal to 3, it is a requirement of bitstream conformance that the value of **cross_component_prediction_enabled_flag** shall be equal to 0.

chroma_qp_offset_list_enabled_flag equal to 1 specifies that the **cu_chroma_qp_offset_flag** may be present in the transform unit syntax. **chroma_qp_offset_list_enabled_flag** equal to 0 specifies that the **cu_chroma_qp_offset_flag** is not present in the transform unit syntax. When **ChromaArrayType** is equal to 0, it is a requirement of bitstream conformance that the value of **chroma_qp_offset_list_enabled_flag** shall be equal to 0.

diff_cu_chroma_qp_offset_depth specifies the difference between the luma coding tree block size and the minimum luma coding block size of coding units that convey **cu_chroma_qp_offset_flag**. The value of **diff_cu_chroma_qp_offset_depth** shall be in the range of 0 to **log2_diff_max_min_luma_coding_block_size**, inclusive.

The variable **Log2MinCuChromaQpOffsetSize** is derived as follows:

$$\text{Log2MinCuChromaQpOffsetSize} = \text{CtbLog2SizeY} - \text{diff_cu_chroma_qp_offset_depth} \quad (7-39)$$

chroma_qp_offset_list_len_minus1 plus 1 specifies the number of **cb_qp_offset_list[i]** and **cr_qp_offset_list[i]** syntax elements that are present in the PPS. The value of **chroma_qp_offset_list_len_minus1** shall be in the range of 0 to 5, inclusive.

cb_qp_offset_list[i] and **cr_qp_offset_list[i]** specify offsets used in the derivation of Qp'_{cb} and Qp'_{cr} , respectively. The values of **cb_qp_offset_list[i]** and **cr_qp_offset_list[i]** shall be in the range of -12 to +12, inclusive.

log2_sao_offset_scale_luma is the base 2 logarithm of the scaling parameter that is used to scale SAO offset values for luma samples. The value of **log2_sao_offset_scale_luma** shall be in the range of 0 to $\text{Max}(0, \text{BitDepth}_Y - 10)$, inclusive. When not present, the value of **log2_sao_offset_scale_luma** is inferred to be equal to 0.

log2_sao_offset_scale_chroma is the base 2 logarithm of the scaling parameter that is used to scale SAO offset values for chroma samples. The value of **log2_sao_offset_scale_chroma** shall be in the range

of 0 to $\text{Max}(0, \text{BitDepth}_c - 10)$, inclusive. When not present, the value of $\text{log}_2\text{-sao_offset_scale_chroma}$ is inferred to be equal to 0.

7.4.3.3.3 Picture parameter set screen content coding extension semantics

pps_curr_pic_ref_enabled_flag equal to 1 specifies that a picture referring to the PPS may be included in a reference picture list of a slice of the picture itself. **pps_curr_pic_ref_enabled_flag** equal to 0 specifies that a picture referring to the PPS is never included in a reference picture list of a slice of the picture itself. When not present, the value of **pps_curr_pic_ref_enabled_flag** is inferred to be equal to 0.

It is a requirement of bitstream conformance that when **sps_curr_pic_ref_enabled_flag** is equal to 0, the value of **pps_curr_pic_ref_enabled_flag** shall be equal to 0.

The variable **TwoVersionsOfCurrDecPicFlag** is derived as follows:

$$\begin{aligned} \text{TwoVersionsOfCurrDecPicFlag} = & \text{pps_curr_pic_ref_enabled_flag} \ \&\& \\ & (\text{sample_adaptive_offset_enabled_flag} \ || \ !\text{pps_deblocking_filter_disabled_flag} \ || \\ & \text{deblocking_filter_override_enabled_flag}) \end{aligned} \quad (7-40)$$

When **sps_max_dec_pic_buffering_minus1[TemporalId]** is equal to 0, the value of **TwoVersionsOfCurrDecPicFlag** shall be equal to 0.

residual_adaptive_colour_transform_enabled_flag equal to 1 specifies that an adaptive colour transform may be applied to the residual in the decoding process. **residual_adaptive_colour_transform_enabled_flag** equal to 0 specifies that adaptive colour transform is not applied to the residual. When not present, the value of **residual_adaptive_colour_transform_enabled_flag** is inferred to be equal to 0.

When **ChromaArrayType** is not equal to 3, **residual_adaptive_colour_transform_enabled_flag** shall be equal to 0.

pps_slice_act_qp_offsets_present_flag equal to 1 specifies that **slice_act_y_qp_offset**, **slice_act_cb_qp_offset**, **slice_act_cr_qp_offset** are present in the slice header. **pps_slice_act_qp_offsets_present_flag** equal to 0 specifies that **slice_act_y_qp_offset**, **slice_act_cb_qp_offset**, **slice_act_cr_qp_offset** are not present in the slice header. When not present, the value of **pps_slice_act_qp_offsets_present_flag** is inferred to be equal to 0.

pps_act_y_qp_offset_plus5, **pps_act_cb_qp_offset_plus5** and **pps_act_cr_qp_offset_plus3** are used to determine the offsets that are applied to the quantization parameter values **qP** derived in 8.6.2 for the luma, Cb and Cr components, respectively, when **tu_residual_act_flag[xTbY][yTbY]** is equal to 1. When not present, the values of **pps_act_y_qp_offset_plus5**, **pps_act_cb_qp_offset_plus5** and **pps_act_cr_qp_offset_plus3** are inferred to be equal to 0.

The variable **PpsActQpOffsetY** is set equal to **pps_act_y_qp_offset_plus5** – 5.

The variable **PpsActQpOffsetCb** is set equal to **pps_act_cb_qp_offset_plus5** – 5.

The variable **PpsActQpOffsetCr** is set equal to **pps_act_cr_qp_offset_plus3** – 3.

NOTE The constant offset values of 5, 5, and 3 above are applied because the adaptive colour transformation that is applied to the residual when **tu_residual_act_flag[xTbY][yTbY]** is equal to 1 is not an orthonormal transformation.

It is a requirement of bitstream conformance that the values of **PpsActQpOffsetY**, **PpsActQpOffsetCb**, and **PpsActQpOffsetCr** shall be in the range of –12 to +12, inclusive.

pps_palette_predictor_initializer_present_flag equal to 1 specifies that the palette predictor initializers used for the pictures referring to the PPS are derived based on the palette predictor initializers specified by the PPS. **pps_palette_predictor_initializer_flag** equal to 0 specifies that the palette predictor initializers used for the pictures referring to the PPS are inferred to be equal to those specified by the active SPS. When not present, the value of **pps_palette_predictor_initializer_present_flag** is inferred to be equal to 0.

ISO/IEC 23008-2:2017(E)

It is a requirement of bitstream conformance that the value of `pps_palette_predictor_initializer_present_flag` shall be equal to 0 when either `palette_max_size` is equal to 0 or `palette_mode_enabled_flag` is equal to 0.

pps_num_palette_predictor_initializer specifies the number of entries in the picture palette predictor initializer.

It is a requirement of bitstream conformance that the value of `pps_num_palette_predictor_initializer` shall be less than or equal to `PaletteMaxPredictorSize`.

monochrome_palette_flag equal to 1 specifies that the pictures that refer to this PPS are monochrome. `monochrome_palette_flag` equal to 0 specifies that the pictures that refer to this PPS have multiple components.

It is a requirement of bitstream conformance that the value of the `monochrome_palette_flag` shall be equal to (`chroma_format_idc = 0`).

luma_bit_depth_entry_minus8 plus 8 specifies the bit depth of the luma component of the entries of the palette predictor initializer. It is a requirement of bitstream conformance that the value of `luma_bit_depth_entry_minus8` shall be equal to the value of `bit_depth_luma_minus8`.

chroma_bit_depth_entry_minus8 plus 8 specifies the bit depth of the chroma components of the entries of the palette predictor initializer. It is a requirement of bitstream conformance that the value of `chroma_bit_depth_entry_minus8` shall be equal to the value of `bit_depth_chroma_minus8`.

pps_palette_predictor_initializers[comp][i] specifies the value of the comp-th component of the i-th palette entry in the PPS that is used to initialize the array `PredictorPaletteEntries`. For values of i in the range of 0 to `pps_num_palette_predictor_initializer - 1`, inclusive, the number of bits used to represent `pps_palette_predictor_initializers[0][i]` is `luma_bit_depth_entry_minus8 + 8`, and the number of bits used to represent `pps_palette_predictor_initializers[1][i]` and `pps_palette_predictor_initializers[2][i]` is `chroma_bit_depth_entry_minus8 + 8`.

7.4.3.4 Supplemental enhancement information RBSP semantics

Supplemental Enhancement Information (SEI) contains information that is not necessary to decode the samples of coded pictures from VCL NAL units. An SEI RBSP contains one or more SEI messages.

7.4.3.5 Access unit delimiter RBSP semantics

The access unit delimiter may be used to indicate the type of slices present in the coded pictures in the access unit containing the access unit delimiter NAL unit and to simplify the detection of the boundary between access units. There is no normative decoding process associated with the access unit delimiter.

pic_type indicates that the `slice_type` values for all slices of the coded pictures in the access unit containing the access unit delimiter NAL unit are members of the set listed in Table 7-2 for the given value of `pic_type`. The value of `pic_type` shall be equal to 0, 1, or 2 in bitstreams conforming to this version of this document. Other values of `pic_type` are reserved for future use by ITU-T | ISO/IEC. Decoders conforming to this version of this document shall ignore reserved values of `pic_type`.

Table 7-2 — Interpretation of `pic_type`

<code>pic_type</code>	<code>slice_type</code> values that may be present in the coded picture
0	I
1	P, I
2	B, P, I

7.4.3.6 End of sequence RBSP semantics

When included in a NAL unit with `nuh_layer_id` equal to 0, the end of sequence RBSP specifies that the current access unit is the last access unit in the coded video sequence in decoding order and the next subsequent access unit in the bitstream in decoding order (if any) is an IRAP access unit with `NoRaslOutputFlag` equal to 1. The syntax content of the SODB and RBSP for the end of sequence RBSP are empty.

7.4.3.7 End of bitstream RBSP semantics

The end of bitstream RBSP indicates that no additional NAL units are present in the bitstream that are subsequent to the end of bitstream RBSP in decoding order. The syntax content of the SODB and RBSP for the end of bitstream RBSP are empty.

NOTE When an elementary stream contains more than one bitstream, the last NAL unit of the last access unit of a bitstream must contain an end of bitstream NAL unit and the first access unit of the subsequent bitstream must be an IRAP access unit. This IRAP access unit may be a CRA, BLA, or IDR access unit.

7.4.3.8 Filler data RBSP semantics

The filler data RBSP contains bytes whose value shall be equal to 0xFF. No normative decoding process is specified for a filler data RBSP.

ff_byte is a byte equal to 0xFF.

7.4.3.9 Slice segment layer RBSP semantics

The slice segment layer RBSP consists of a slice segment header and slice segment data.

7.4.3.10 RBSP slice segment trailing bits semantics

cabac_zero_word is a byte-aligned sequence of two bytes equal to 0x0000.

Let `NumBytesInVclNalUnits` be the sum of the values of `NumBytesInNalUnit` for all VCL NAL units of a coded picture.

Let `BinCountsInNalUnits` be the number of times that the parsing process function `DecodeBin()`, specified in 9.3.4.3, is invoked to decode the contents of all VCL NAL units of a coded picture.

Let the variable `RawMinCuBits` be derived as follows:

$$\text{RawMinCuBits} = \text{MinCbSize}_Y * \text{MinCbSize}_Y * (\text{BitDepth}_Y + 2 * \text{BitDepth}_C / (\text{SubWidth}_C * \text{SubHeight}_C)) \quad (7-41)$$

The value of `BinCountsInNalUnits` shall be less than or equal to $(32 \div 3) * \text{NumBytesInVclNalUnits} + (\text{RawMinCuBits} * \text{PicSizeInMinCbs}_Y) \div 32$.

NOTE The constraint on the maximum number of bins resulting from decoding the contents of the coded slice segment NAL units can be met by inserting a number of `cabac_zero_word` syntax elements to increase the value of `NumBytesInVclNalUnits`. Each `cabac_zero_word` is represented in a NAL unit by the three-byte sequence 0x000003 (as a result of the constraints on NAL unit contents that result in requiring inclusion of an `emulation_prevention_three_byte` for each `cabac_zero_word`).

7.4.3.11 RBSP trailing bits semantics

rbsp_stop_one_bit shall be equal to 1.

rbsp_alignment_zero_bit shall be equal to 0.

7.4.3.12 Byte alignment semantics

alignment_bit_equal_to_one shall be equal to 1.

alignment_bit_equal_to_zero shall be equal to 0.

7.4.4 Profile, tier, and level semantics

general_profile_space specifies the context for the interpretation of `general_profile_idc` and `general_profile_compatibility_flag[j]` for all values of `j` in the range of 0 to 31, inclusive. The value of `general_profile_space` shall be equal to 0 in bitstreams conforming to this version of this document. Other values for `general_profile_space` are reserved for future use by ITU-T | ISO/IEC. Decoders shall ignore the CVS when `general_profile_space` is not equal to 0.

general_tier_flag specifies the tier context for the interpretation of `general_level_idc` as specified in Annex A.

general_profile_idc, when `general_profile_space` is equal to 0, indicates a profile to which the CVS conforms as specified in Annex A. Bitstreams shall not contain values of `general_profile_idc` other than those specified in Annex A. Other values of `general_profile_idc` are reserved for future use by ITU-T | ISO/IEC.

general_profile_compatibility_flag[j] equal to 1, when `general_profile_space` is equal to 0, indicates that the CVS conforms to the profile indicated by `general_profile_idc` equal to `j` as specified in Annex A. When `general_profile_space` is equal to 0, `general_profile_compatibility_flag[general_profile_idc]` shall be equal to 1. The value of `general_profile_compatibility_flag[j]` shall be equal to 0 for any value of `j` that is not specified as an allowed value of `general_profile_idc` in Annex A.

general_progressive_source_flag and **general_interlaced_source_flag** are interpreted as follows:

- If `general_progressive_source_flag` is equal to 1 and `general_interlaced_source_flag` is equal to 0, the source scan type of the pictures in the CVS should be interpreted as progressive only.
- Otherwise, if `general_progressive_source_flag` is equal to 0 and `general_interlaced_source_flag` is equal to 1, the source scan type of the pictures in the CVS should be interpreted as interlaced only.
- Otherwise, if `general_progressive_source_flag` is equal to 0 and `general_interlaced_source_flag` is equal to 0, the source scan type of the pictures in the CVS should be interpreted as unknown or unspecified.
- Otherwise (`general_progressive_source_flag` is equal to 1 and `general_interlaced_source_flag` is equal to 1), the source scan type of each picture in the CVS is indicated at the picture level using the syntax element `source_scan_type` in a picture timing SEI message.

NOTE 1 Decoders can ignore the values of `general_progressive_source_flag` and `general_interlaced_source_flag` for purposes other than determining the value to be inferred for `frame_field_info_present_flag` when `vui_parameters_present_flag` is equal to 0, as there are no other decoding process requirements associated with the values of these flags. Moreover, the actual source scan type of the pictures is outside the scope of this document, and the method by which the encoder selects the values of `general_progressive_source_flag` and `general_interlaced_source_flag` is unspecified.

general_non_packed_constraint_flag equal to 1 specifies that there are neither frame packing arrangement SEI messages nor segmented rectangular frame packing arrangement SEI messages present in the CVS. `general_non_packed_constraint_flag` equal to 0 indicates that there may or may not be one or more frame packing arrangement SEI messages or segmented rectangular frame packing arrangement SEI messages present in the CVS.

NOTE 2 Decoders can ignore the value of `general_non_packed_constraint_flag`, as there are no decoding process requirements associated with the presence or interpretation of frame packing arrangement SEI messages or segmented rectangular frame packing arrangement SEI messages.

general_frame_only_constraint_flag equal to 1 specifies that `field_seq_flag` is equal to 0. `general_frame_only_constraint_flag` equal to 0 indicates that `field_seq_flag` may or may not be equal to 0.

NOTE 3 Decoders can ignore the value of `general_frame_only_constraint_flag`, as there are no decoding process requirements associated with the value of `field_seq_flag`.

NOTE 4 When `general_progressive_source_flag` is equal to 1, `general_frame_only_constraint_flag` may or may not be equal to 1.

`general_max_12bit_constraint_flag`, `general_max_10bit_constraint_flag`, `general_max_8bit_constraint_flag`, `general_max_422chroma_constraint_flag`, `general_max_420chroma_constraint_flag`, `general_max_monochrome_constraint_flag`, `general_intra_constraint_flag`, `general_one_picture_only_constraint_flag`, `general_lower_bit_rate_constraint_flag`, and `general_max_14bit_constraint_flag`, when present, have semantics specified in Annex A when the profile indicated by `general_profile_idc` or `general_profile_compatibility_flag[j]` is a profile specified in Annex A. When `profilePresentFlag` is equal to 1 and one or more of these syntax elements are not present, their values are inferred to be equal to 0. When `general_profile_idc` is not equal to 10 and is not in the range of 4 to 7, inclusive, and `general_profile_compatibility_flag[10]` is not equal to 1 and `general_profile_compatibility_flag[j]` is not equal to 1 for any value of `j` in the range of 4 to 7, inclusive, the value of each of these syntax elements shall be equal to 0.

`general_reserved_zero_33bits`, when present, shall be equal to 0 in bitstreams conforming to this version of this document. Other values for `general_reserved_zero_33bits` are reserved for future use by ITU-T | ISO/IEC. Decoders shall ignore the value of `general_reserved_zero_33bits`.

`general_reserved_zero_34bits`, when present, shall be equal to 0 in bitstreams conforming to this version of this document. Other values for `general_reserved_zero_34bits` are reserved for future use by ITU-T | ISO/IEC. Decoders shall ignore the value of `general_reserved_zero_34bits`.

`general_reserved_zero_43bits`, when present, shall be equal to 0 in bitstreams conforming to this version of this document. Other values for `general_reserved_zero_43bits` are reserved for future use by ITU-T | ISO/IEC. Decoders shall ignore the value of `general_reserved_zero_43bits`.

`general_inbld_flag` equal to 1 specifies that the INBLD capability as specified in Annex F is required for decoding of the layer to which the `profile_tier_level()` syntax structure applies. `general_inbld_flag` equal to 0 specifies that the INBLD capability as specified in Annex F is not required for decoding of the layer to which the `profile_tier_level()` syntax structure applies. When `profilePresentFlag` is equal to 1 and `general_profile_idc` is not present, the value of `general_profile_idc` is inferred to be equal to 0. When `general_profile_idc` is not equal to 9 and is not in the range of 1 to 5, inclusive, and `general_profile_compatibility_flag[9]` is not equal to 1 and `general_profile_compatibility_flag[j]` is not equal to 1 for any value of `j` in the range of 1 to 5, inclusive, the value of `general_inbld_flag` shall be equal to 0.

`general_reserved_zero_bit`, when present, shall be equal to 0 in bitstreams conforming to this version of this document. The value 1 for `general_reserved_zero_1bit` is reserved for future use by ITU-T | ISO/IEC. Decoders shall ignore the value of `general_reserved_zero_bit`.

`general_level_idc` indicates a level to which the CVS conforms as specified in Annex A. Bitstreams shall not contain values of `general_level_idc` other than those specified in Annex A. Other values of `general_level_idc` are reserved for future use by ITU-T | ISO/IEC.

NOTE 5 A greater value of `general_level_idc` indicates a higher level. The maximum level signalled in the VPS for a CVS may be higher than the level signalled in the SPS for the same CVS.

NOTE 6 When the coded video sequence conforms to multiple profiles, `general_profile_idc` is expected to indicate the profile that provides the preferred decoded result or the preferred bitstream identification, as determined by the encoder (in a manner not specified in this document).

NOTE 7 The syntax elements `general_reserved_zero_33bits`, `general_reserved_zero_34bits` and `general_reserved_zero_43bits` may be used in future versions of this document to indicate further constraints on the bitstream (e.g. that a particular syntax combination that would otherwise be permitted by the indicated values of `general_profile_compatibility_flag[j]`, is not used).

`sub_layer_profile_present_flag[i]` equal to 1, specifies that profile information is present in the `profile_tier_level()` syntax structure for the sub-layer representation with `TemporalId` equal to `i`.

sub_layer_profile_present_flag[i] equal to 0 specifies that profile information is not present in the profile_tier_level() syntax structure for the sub-layer representation with TemporalId equal to i. When profilePresentFlag is equal to 0, sub_layer_profile_present_flag[i] shall be equal to 0.

sub_layer_level_present_flag[i] equal to 1 specifies that level information is present in the profile_tier_level() syntax structure for the sub-layer representation with TemporalId equal to i. sub_layer_level_present_flag[i] equal to 0 specifies that level information is not present in the profile_tier_level() syntax structure for the sub-layer representation with TemporalId equal to i.

reserved_zero_2bits[i] shall be equal to 0 in bitstreams conforming to this version of this document. Other values for reserved_zero_2bits[i] are reserved for future use by ITU-T | ISO/IEC. Decoders shall ignore the value of reserved_zero_2bits[i].

The semantics of the syntax elements **sub_layer_profile_space[i], sub_layer_tier_flag[i], sub_layer_profile_idc[i], sub_layer_profile_compatibility_flag[i][j], sub_layer_progressive_source_flag[i], sub_layer_interlaced_source_flag[i], sub_layer_non_packed_constraint_flag[i], sub_layer_frame_only_constraint_flag[i], sub_layer_max_12bit_constraint_flag[i], sub_layer_max_10bit_constraint_flag[i], sub_layer_max_8bit_constraint_flag[i], sub_layer_max_422chroma_constraint_flag[i], sub_layer_max_420chroma_constraint_flag[i], sub_layer_max_monochrome_constraint_flag[i], sub_layer_intra_constraint_flag[i], sub_layer_one_picture_only_constraint_flag[i], sub_layer_lower_bit_rate_constraint_flag[i], sub_layer_max_14bit_constraint_flag, sub_layer_reserved_zero_33bits[i], sub_layer_reserved_zero_34bits[i], sub_layer_reserved_zero_43bits[i], sub_layer_inbld_flag[i], sub_layer_reserved_zero_bit[i], and sub_layer_level_idc[i]** are, apart from the specification of the inference of not present values, the same as the syntax elements **general_profile_space, general_tier_flag, general_profile_idc, general_profile_compatibility_flag[j], general_progressive_source_flag, general_interlaced_source_flag, general_non_packed_constraint_flag, general_frame_only_constraint_flag, general_max_12bit_constraint_flag, general_max_10bit_constraint_flag, general_max_8bit_constraint_flag, general_max_422chroma_constraint_flag, general_max_420chroma_constraint_flag, general_max_monochrome_constraint_flag, general_intra_constraint_flag, general_one_picture_only_constraint_flag, general_lower_bit_rate_constraint_flag, general_max_14bit_constraint_flag, general_reserved_zero_33bits, general_reserved_zero_34bits, general_reserved_zero_43bits, general_inbld_flag, general_reserved_zero_bit, and general_level_idc**, respectively, but apply to the sub-layer representation with TemporalId equal to i.

When not present, the value of sub_layer_tier_flag[i] is inferred to be equal to 0.

NOTE 8 It is possible that sub_layer_tier_flag[i] is not present and sub_layer_level_idc[i] is present. In this case, a default value of sub_layer_tier_flag[i] is needed for interpretation of sub_layer_level_idc[i].

When the profile_tier_level() syntax structure is included in an SPS or is the first profile_tier_level() syntax structure in a VPS, and any of the syntax elements **sub_layer_profile_space[i], sub_layer_profile_idc[i], sub_layer_profile_compatibility_flag[i][j], sub_layer_progressive_source_flag[i], sub_layer_interlaced_source_flag[i], sub_layer_non_packed_constraint_flag[i], sub_layer_frame_only_constraint_flag[i], sub_layer_max_12bit_constraint_flag[i], sub_layer_max_10bit_constraint_flag[i], sub_layer_max_8bit_constraint_flag[i], sub_layer_max_422chroma_constraint_flag[i], sub_layer_max_420chroma_constraint_flag[i], sub_layer_max_monochrome_constraint_flag[i], sub_layer_intra_constraint_flag[i], sub_layer_one_picture_only_constraint_flag[i], sub_layer_lower_bit_rate_constraint_flag[i], sub_layer_max_14bit_constraint_flag, sub_layer_reserved_zero_33bits[i], sub_layer_reserved_zero_34bits[i], sub_layer_reserved_zero_43bits[i], sub_layer_inbld_flag[i], sub_layer_reserved_zero_1bit[i], and sub_layer_level_idc[i]** is not present for any value of i in the range of 0 to maxNumSubLayersMinus1 – 1, inclusive, in the profile_tier_level() syntax structure, the value of the syntax element is inferred as follows (in decreasing order of i values from maxNumSubLayersMinus1 – 1 to 0):

- If the value of *i* is equal to `maxNumSubLayersMinus1`, the value of the syntax element is inferred to be equal to the value of the corresponding syntax element prefixed with “general_” of the same `profile_tier_level()` syntax structure.

NOTE 9 For example, in this case, if `sub_layer_profile_space[i]` is not present, the value is inferred to be equal to `general_profile_space` of the same `profile_tier_level()` syntax structure.

- Otherwise (the value of *i* is less than `maxNumSubLayersMinus1`), the value of the syntax element is inferred to be equal to the corresponding syntax element with *i* being replaced with *i* + 1 of the same `profile_tier_level()` syntax structure.

NOTE 10 For example, in this case, if `sub_layer_profile_space[i]` is not present, the value is inferred to be equal to `sub_layer_profile_space[i + 1]` of the same `profile_tier_level()` syntax structure.

7.4.5 Scaling list data semantics

`scaling_list_pred_mode_flag[sizeId][matrixId]` equal to 0 specifies that the values of the scaling list are the same as the values of a reference scaling list. The reference scaling list is specified by `scaling_list_pred_matrix_id_delta[sizeId][matrixId]`. `scaling_list_pred_mode_flag[sizeId][matrixId]` equal to 1 specifies that the values of the scaling list are explicitly signalled.

`scaling_list_pred_matrix_id_delta[sizeId][matrixId]` specifies the reference scaling list used to derive `ScalingList[sizeId][matrixId]` as follows:

- If `scaling_list_pred_matrix_id_delta[sizeId][matrixId]` is equal to 0, the scaling list is inferred from the default scaling list `ScalingList[sizeId][matrixId][i]` as specified in Table 7-5 and Table 7-6 for $i = 0..Min(63, (1 << (4 + (sizeId << 1))) - 1)$.
- Otherwise, the scaling list is inferred from the reference scaling list as follows:

$$refMatrixId = matrixId - scaling_list_pred_matrix_id_delta[sizeId][matrixId] * (sizeId = 3 ? 3 : 1) \tag{7-42}$$

$$ScalingList[sizeId][matrixId][i] = ScalingList[sizeId][refMatrixId][i] \text{ with } i = 0..Min(63, (1 << (4 + (sizeId << 1))) - 1) \tag{7-43}$$

If `sizeId` is less than or equal to 2, the value of `scaling_list_pred_matrix_id_delta[sizeId][matrixId]` shall be in the range of 0 to `matrixId`, inclusive. Otherwise (`sizeId` is equal to 3), the value of `scaling_list_pred_matrix_id_delta[sizeId][matrixId]` shall be in the range of 0 to `matrixId / 3`, inclusive.

Table 7-3 — Specification of `sizeId`

Size of quantization matrix	<code>sizeId</code>
4x4	0
8x8	1
16x16	2
32x32	3

Table 7-4 — Specification of matrixId according to sizeId, prediction mode and colour component

sizeId	CuPredMode	cldx (colour component)	matrixId
0, 1, 2, 3	MODE_INTRA	0 (Y)	0
0, 1, 2, 3	MODE_INTRA	1 (Cb)	1
0, 1, 2, 3	MODE_INTRA	2 (Cr)	2
0, 1, 2, 3	MODE_INTER	0 (Y)	3
0, 1, 2, 3	MODE_INTER	1 (Cb)	4
0, 1, 2, 3	MODE_INTER	2 (Cr)	5

scaling_list_dc_coef_minus8[sizeId - 2][matrixId] plus 8 specifies the value of the variable ScalingFactor[2][matrixId][0][0] for the scaling list for the 16x16 size when sizeId is equal to 2 and specifies the value of ScalingFactor[3][matrixId][0][0] for the scaling list for the 32x32 size when sizeId is equal to 3. The value of scaling_list_dc_coef_minus8[sizeId - 2][matrixId] shall be in the range of -7 to 247, inclusive.

When scaling_list_pred_mode_flag[sizeId][matrixId] is equal to 0, scaling_list_pred_matrix_id_delta[sizeId][matrixId] is equal to 0, and sizeId is greater than 1, the value of scaling_list_dc_coef_minus8[sizeId - 2][matrixId] is inferred to be equal to 8.

When scaling_list_pred_matrix_id_delta[sizeId][matrixId] is not equal to 0 and sizeId is greater than 1, the value of scaling_list_dc_coef_minus8[sizeId - 2][matrixId] is inferred to be equal to scaling_list_dc_coef_minus8[sizeId - 2][refMatrixId], where the value of refMatrixId is given by Formula (7-42).

scaling_list_delta_coef specifies the difference between the current matrix coefficient ScalingList[sizeId][matrixId][i] and the previous matrix coefficient

ScalingList[sizeId][matrixId][i - 1], when scaling_list_pred_mode_flag[sizeId][matrixId] is equal to 1. The value of scaling_list_delta_coef shall be in the range of -128 to 127, inclusive. The value of ScalingList[sizeId][matrixId][i] shall be greater than 0.

Table 7-5 — Specification of default values of ScalingList[0][matrixId][i] with i = 0..15

i	0	1	2	3	4	5	6	7	8	9	10	11	12	13	14	15
ScalingList[0][0..5][i]	16	16	16	16	16	16	16	16	16	16	16	16	16	16	16	16

Table 7-6 — Specification of default values of ScalingList[1..3][matrixId][i] with i = 0..63

i	0	1	2	3	4	5	6	7	8	9	10	11	12	13	14	15
ScalingList[1..3][0..2][i]	16	16	16	16	16	16	16	16	16	16	17	16	17	16	17	18
ScalingList[1..3][3..5][i]	16	16	16	16	16	16	16	16	16	16	17	17	17	17	17	18
i - 16	0	1	2	3	4	5	6	7	8	9	10	11	12	13	14	15
ScalingList[1..3][0..2][i]	17	18	18	17	18	21	19	20	21	20	19	21	24	22	22	24
ScalingList[1..3][3..5][i]	18	18	18	18	18	20	20	20	20	20	20	20	24	24	24	24
i - 32	0	1	2	3	4	5	6	7	8	9	10	11	12	13	14	15
ScalingList[1..3][0..2][i]	24	22	22	24	25	25	27	30	27	25	25	29	31	35	35	31
ScalingList[1..3][3..5][i]	24	24	24	24	25	25	25	25	25	25	25	28	28	28	28	28
i - 48	0	1	2	3	4	5	6	7	8	9	10	11	12	13	14	15

ScalingList[1..3][0..2][i]	29	36	41	44	41	36	47	54	54	47	65	70	65	88	88	11 5
ScalingList[1..3][3..5][i]	28	33	33	33	33	33	41	41	41	41	54	54	54	71	71	91

The four-dimensional array ScalingFactor[sizeId][matrixId][x][y], with $x, y = 0..(1 \ll (2 + \text{sizeId})) - 1$, specifies the array of scaling factors according to the variables sizeId specified in Table 7-3 and matrixId specified in Table 7-4.

The elements of the quantization matrix of size 4x4, ScalingFactor[0][matrixId][][], are derived as follows:

$$\text{ScalingFactor}[0][\text{matrixId}][x][y] = \text{ScalingList}[0][\text{matrixId}][i] \quad (7-44)$$

with $i = 0..15$, $\text{matrixId} = 0..5$, $x = \text{ScanOrder}[2][0][i][0]$, and $y = \text{ScanOrder}[2][0][i][1]$.

The elements of the quantization matrix of size 8x8, ScalingFactor[1][matrixId][][], are derived as follows:

$$\text{ScalingFactor}[1][\text{matrixId}][x][y] = \text{ScalingList}[1][\text{matrixId}][i] \quad (7-45)$$

with $i = 0..63$, $\text{matrixId} = 0..5$, $x = \text{ScanOrder}[3][0][i][0]$, and $y = \text{ScanOrder}[3][0][i][1]$.

The elements of the quantization matrix of size 16x16, ScalingFactor[2][matrixId][][], are derived as follows:

$$\text{ScalingFactor}[2][\text{matrixId}][x * 2 + k][y * 2 + j] = \text{ScalingList}[2][\text{matrixId}][i] \quad (7-46)$$

with $i = 0..63$, $j = 0..1$, $k = 0..1$, $\text{matrixId} = 0..5$, $x = \text{ScanOrder}[3][0][i][0]$, and $y = \text{ScanOrder}[3][0][i][1]$.

$$\text{ScalingFactor}[2][\text{matrixId}][0][0] = \text{scaling_list_dc_coef_minus8}[0][\text{matrixId}] + 8 \quad (7-47)$$

with $\text{matrixId} = 0..5$.

The elements of the quantization matrix of size 32x32, ScalingFactor[3][matrixId][][], are derived as follows:

$$\text{ScalingFactor}[3][\text{matrixId}][x * 4 + k][y * 4 + j] = \text{ScalingList}[3][\text{matrixId}][i] \quad (7-48)$$

with $i = 0..63$, $j = 0..3$, $k = 0..3$, $\text{matrixId} = 0, 3$, $x = \text{ScanOrder}[3][0][i][0]$, and $y = \text{ScanOrder}[3][0][i][1]$.

$$\text{ScalingFactor}[3][\text{matrixId}][0][0] = \text{scaling_list_dc_coef_minus8}[1][\text{matrixId}] + 8 \quad (7-49)$$

with $\text{matrixId} = 0, 3$.

When ChromaArrayType is equal to 3, the elements of the chroma quantization matrix of size 32x32, ScalingFactor[3][matrixId][][], with $\text{matrixId} = 1, 2, 4$, and 5, are derived as follows:

$$\text{ScalingFactor}[3][\text{matrixId}][x * 4 + k][y * 4 + j] = \text{ScalingList}[2][\text{matrixId}][i] \quad (7-50)$$

with $i = 0..63$, $j = 0..3$, $k = 0..3$, $x = \text{ScanOrder}[3][0][i][0]$, and $y = \text{ScanOrder}[3][0][i][1]$.

$$\text{ScalingFactor}[3][\text{matrixId}][0][0] = \text{scaling_list_dc_coef_minus8}[0][\text{matrixId}] + 8 \quad (7-51)$$

7.4.6 Supplemental enhancement information message semantics

Each SEI message consists of the variables specifying the type payloadType and size payloadSize of the SEI message payload. SEI message payloads are specified in Annex D. The derived SEI message payload size payloadSize is specified in bytes and shall be equal to the number of RBSP bytes in the SEI message payload.

ISO/IEC 23008-2:2017(E)

NOTE The NAL unit byte sequence containing the SEI message might include one or more emulation prevention bytes (represented by `emulation_prevention_three_byte` syntax elements). Since the payload size of an SEI message is specified in RBSP bytes, the quantity of emulation prevention bytes is not included in the size `payloadSize` of an SEI payload.

ff_byte is a byte equal to 0xFF identifying a need for a longer representation of the syntax structure that it is used within.

last_payload_type_byte is the last byte of the payload type of an SEI message.

last_payload_size_byte is the last byte of the payload size of an SEI message.

7.4.7 Slice segment header semantics

7.4.7.1 General slice segment header semantics

When present, the value of the slice segment header syntax elements `slice_pic_parameter_set_id`, `pic_output_flag`, `no_output_of_prior_pics_flag`, `slice_pic_order_cnt_lsb`, `short_term_ref_pic_set_sps_flag`, `short_term_ref_pic_set_idx`, `num_long_term_sps`, `num_long_term_pics`, and `slice_temporal_mvp_enabled_flag` shall be the same in all slice segment headers of a coded picture. When present, the value of the slice segment header syntax elements `lt_idx_sps[i]`, `poc_lsb_lt[i]`, `used_by_curr_pic_lt_flag[i]`, `delta_poc_msb_present_flag[i]`, and `delta_poc_msb_cycle_lt[i]` shall be the same in all slice segment headers of a coded picture for each possible value of `i`.

first_slice_segment_in_pic_flag equal to 1 specifies that the slice segment is the first slice segment of the picture in decoding order. `first_slice_segment_in_pic_flag` equal to 0 specifies that the slice segment is not the first slice segment of the picture in decoding order.

NOTE 1 This syntax element may be used for detection of the boundary between coded pictures that are consecutive in decoding order. However, when IDR pictures are consecutive in decoding order and have the same NAL unit type, loss of the first slice of an IDR picture can cause a problem with detection of the boundary between the coded pictures. This can occur, e.g. in the transmission of all-intra-coded video in an error-prone environment. This problem can be mitigated by alternately using the two different IDR NAL unit types (IDR_W_RADL and IDR_N_LP) for any two consecutive IDR pictures. The use of the temporal sub-layer zero index SEI message can also be helpful, as that SEI message includes the syntax element `irap_pic_id`, the value of which is different for IRAP pictures that are consecutive in decoding order. Some system environments have other provisions that can be helpful for picture boundary detection as well, such as the use of presentation timestamps in Rec. ITU-T H.222.0 | ISO/IEC 13818-1 systems, access unit framing in the ISO/IEC 14496-12 ISO base media file format, or the marker bit in IETF RFC 3550 real-time transport protocol headers.

no_output_of_prior_pics_flag affects the output of previously-decoded pictures in the decoded picture buffer after the decoding of an IDR or a BLA picture that is not the first picture in the bitstream as specified in Annex C.

slice_pic_parameter_set_id specifies the value of `pps_pic_parameter_set_id` for the PPS in use. The value of `slice_pic_parameter_set_id` shall be in the range of 0 to 63, inclusive.

Let `activePPS` be the PPS that has `pps_pic_parameter_set_id` equal to `slice_pic_parameter_set_id`, and let `activeSPS` be the SPS that has `sps_seq_parameter_set_id` equal to `pps_seq_parameter_set_id` of `activePPS`. It is a requirement of bitstream conformance that the following constraints apply:

- The value of `TemporalId` of `activePPS` shall be less than or equal to the value of `TemporalId` of the current picture.
- The value of `nuh_layer_id` of `activePPS` shall be less than or equal to the value of `nuh_layer_id` of the current picture.
- The value of `nuh_layer_id` of `activeSPS` shall be less than or equal to the value of `nuh_layer_id` of the current picture.

dependent_slice_segment_flag equal to 1 specifies that the value of each slice segment header syntax element that is not present is inferred to be equal to the value of the corresponding slice segment header syntax element in the slice header. When not present, the value of **dependent_slice_segment_flag** is inferred to be equal to 0.

The variable **SliceAddrRs** is derived as follows:

- If **dependent_slice_segment_flag** is equal to 0, **SliceAddrRs** is set equal to **slice_segment_address**.
- Otherwise, **SliceAddrRs** is set equal to **SliceAddrRs** of the preceding slice segment containing the coding tree block for which the coding tree block address is $\text{CtbAddrTsToRs}[\text{CtbAddrRsToTs}[\text{slice_segment_address}] - 1]$.

slice_segment_address specifies the address of the first coding tree block in the slice segment, in coding tree block raster scan of a picture. The length of the **slice_segment_address** syntax element is $\text{Ceil}(\text{Log}_2(\text{PicSizeInCtbsY}))$ bits. The value of **slice_segment_address** shall be in the range of 0 to $\text{PicSizeInCtbsY} - 1$, inclusive, and the value of **slice_segment_address** shall not be equal to the value of **slice_segment_address** of any other coded slice segment NAL unit of the same coded picture. When **slice_segment_address** is not present, it is inferred to be equal to 0.

The variable **CtbAddrInRs**, specifying a coding tree block address in coding tree block raster scan of a picture, is set equal to **slice_segment_address**. The variable **CtbAddrInTs**, specifying a coding tree block address in tile scan, is set equal to $\text{CtbAddrRsToTs}[\text{CtbAddrInRs}]$. The variable **CuQpDeltaVal**, specifying the difference between a luma quantization parameter for the coding unit containing **cu_qp_delta_abs** and its prediction, is set equal to 0. The variables **CuQpOffsetCb** and **CuQpOffsetCr**, specifying values to be used when determining the respective values of the Qp'_{cb} and Qp'_{cr} quantization parameters for the coding unit containing **cu_chroma_qp_offset_flag**, are both set equal to 0.

slice_reserved_flag[*i*] has semantics and values that are reserved for future use by ITU-T | ISO/IEC. Decoders shall ignore the presence and value of **slice_reserved_flag**[*i*].

slice_type specifies the coding type of the slice according to Table 7-7.

Table 7-7 — Name association to slice_type

slice_type	Name of slice_type
0	B (B slice)
1	P (P slice)
2	I (I slice)

When **nal_unit_type** has a value in the range of **BLA_W_LP** to **RSV_IRAP_VCL23**, inclusive, i.e. the picture is an IRAP picture, **nuh_layer_id** is equal to 0, and **pps_curr_pic_ref_enabled_flag** is equal to 0, **slice_type** shall be equal to 2.

When **sps_max_dec_pic_buffering_minus1**[*TemporalId*] is equal to 0, **nuh_layer_id** is equal to 0, and **pps_curr_pic_ref_enabled_flag** is equal to 0, **slice_type** shall be equal to 2.

pic_output_flag affects the decoded picture output and removal processes as specified in Annex C. When **pic_output_flag** is not present, it is inferred to be equal to 1.

colour_plane_id specifies the colour plane associated with the current slice RBSP when **separate_colour_plane_flag** is equal to 1. The value of **colour_plane_id** shall be in the range of 0 to 2, inclusive. **colour_plane_id** values 0, 1, and 2 correspond to the Y, Cb, and Cr planes, respectively.

NOTE 2 There is no dependency between the decoding processes of pictures having different values of **colour_plane_id**.

slice_pic_order_cnt_lsb specifies the picture order count modulo **MaxPicOrderCntLsb** for the current picture. The length of the **slice_pic_order_cnt_lsb** syntax element is $\text{log}_2\text{max_pic_order_cnt_lsb_minus4} + 4$ bits. The value of the **slice_pic_order_cnt_lsb** shall be in the

range of 0 to $\text{MaxPicOrderCntLsb} - 1$, inclusive. When $\text{slice_pic_order_cnt_lsb}$ is not present, $\text{slice_pic_order_cnt_lsb}$ is inferred to be equal to 0, except as specified in 8.3.3.1.

short_term_ref_pic_set_sps_flag equal to 1 specifies that the short-term RPS of the current picture is derived based on one of the $\text{st_ref_pic_set}()$ syntax structures in the active SPS that is identified by the syntax element $\text{short_term_ref_pic_set_idx}$ in the slice header. $\text{short_term_ref_pic_set_sps_flag}$ equal to 0 specifies that the short-term RPS of the current picture is derived based on the $\text{st_ref_pic_set}()$ syntax structure that is directly included in the slice headers of the current picture. When $\text{num_short_term_ref_pic_sets}$ is equal to 0, the value of $\text{short_term_ref_pic_set_sps_flag}$ shall be equal to 0.

short_term_ref_pic_set_idx specifies the index, into the list of the $\text{st_ref_pic_set}()$ syntax structures included in the active SPS, of the $\text{st_ref_pic_set}()$ syntax structure that is used for derivation of the short-term RPS of the current picture. The syntax element $\text{short_term_ref_pic_set_idx}$ is represented by $\text{Ceil}(\text{Log}_2(\text{num_short_term_ref_pic_sets}))$ bits. When not present, the value of $\text{short_term_ref_pic_set_idx}$ is inferred to be equal to 0. The value of $\text{short_term_ref_pic_set_idx}$ shall be in the range of 0 to $\text{num_short_term_ref_pic_sets} - 1$, inclusive.

The variable CurrRpsIdx is derived as follows:

- If $\text{short_term_ref_pic_set_sps_flag}$ is equal to 1, CurrRpsIdx is set equal to $\text{short_term_ref_pic_set_idx}$.
- Otherwise, CurrRpsIdx is set equal to $\text{num_short_term_ref_pic_sets}$.

num_long_term_sps specifies the number of entries in the long-term RPS of the current picture that are derived based on the candidate long-term reference pictures specified in the active SPS. The value of num_long_term_sps shall be in the range of 0 to $\text{num_long_term_ref_pics_sps}$, inclusive. When not present, the value of num_long_term_sps is inferred to be equal to 0.

num_long_term_pics specifies the number of entries in the long-term RPS of the current picture that are directly signalled in the slice header. When not present, the value of $\text{num_long_term_pics}$ is inferred to be equal to 0.

When nuh_layer_id is equal to 0, the value of $\text{num_long_term_pics}$ shall be less than or equal to $\text{sps_max_dec_pic_buffering_minus1}[\text{TemporalId}] - \text{NumNegativePics}[\text{CurrRpsIdx}] - \text{NumPositivePics}[\text{CurrRpsIdx}] - \text{num_long_term_sps} - \text{TwoVersionsOfCurrDecPicFlag}$.

lt_idx_sps[i] specifies an index, into the list of candidate long-term reference pictures specified in the active SPS, of the i -th entry in the long-term RPS of the current picture. The number of bits used to represent $\text{lt_idx_sps}[i]$ is equal to $\text{Ceil}(\text{Log}_2(\text{num_long_term_ref_pics_sps}))$. When not present, the value of $\text{lt_idx_sps}[i]$ is inferred to be equal to 0. The value of $\text{lt_idx_sps}[i]$ shall be in the range of 0 to $\text{num_long_term_ref_pics_sps} - 1$, inclusive.

poc_lsb_lt[i] specifies the value of the picture order count modulo MaxPicOrderCntLsb of the i -th entry in the long-term RPS of the current picture. The length of the $\text{poc_lsb_lt}[i]$ syntax element is $\text{log}_2\text{_max_pic_order_cnt_lsb_minus4} + 4$ bits.

used_by_curr_pic_lt_flag[i] equal to 0 specifies that the i -th entry in the long-term RPS of the current picture is not used for reference by the current picture.

The variables $\text{PocLsbLt}[i]$ and $\text{UsedByCurrPicLt}[i]$ are derived as follows:

- If i is less than num_long_term_sps , $\text{PocLsbLt}[i]$ is set equal to $\text{lt_ref_pic_poc_lsb_sps}[\text{lt_idx_sps}[i]]$ and $\text{UsedByCurrPicLt}[i]$ is set equal to $\text{used_by_curr_pic_lt_sps_flag}[\text{lt_idx_sps}[i]]$.
- Otherwise, $\text{PocLsbLt}[i]$ is set equal to $\text{poc_lsb_lt}[i]$ and $\text{UsedByCurrPicLt}[i]$ is set equal to $\text{used_by_curr_pic_lt_flag}[i]$.

delta_poc_msb_present_flag[i] equal to 1 specifies that **delta_poc_msb_cycle_lt**[i] is present. **delta_poc_msb_present_flag**[i] equal to 0 specifies that **delta_poc_msb_cycle_lt**[i] is not present.

Let **prevTid0Pic** be the previous picture in decoding order that has **TemporalId** equal to 0 and is not a RASL, RADL, or SLNR picture. Let **setOfPrevPocVals** be a set consisting of the following:

- the **PicOrderCntVal** of **prevTid0Pic**;
- the **PicOrderCntVal** of each picture in the RPS of **prevTid0Pic**;
- the **PicOrderCntVal** of each picture that follows **prevTid0Pic** in decoding order and precedes the current picture in decoding order.

When there is more than one value in **setOfPrevPocVals** for which the value modulo **MaxPicOrderCntLsb** is equal to **PocLsbLt**[i], **delta_poc_msb_present_flag**[i] shall be equal to 1.

delta_poc_msb_cycle_lt[i] is used to determine the value of the most significant bits of the picture order count value of the i-th entry in the long-term RPS of the current picture. When **delta_poc_msb_cycle_lt**[i] is not present, it is inferred to be equal to 0.

The variable **DeltaPocMsbCycleLt**[i] is derived as follows:

$$\begin{aligned} &\text{if}(i = 0 \mid i = \text{num_long_term_sps}) \\ &\quad \text{DeltaPocMsbCycleLt}[i] = \text{delta_poc_msb_cycle_lt}[i] \\ &\text{else} \\ &\quad \text{DeltaPocMsbCycleLt}[i] = \text{delta_poc_msb_cycle_lt}[i] + \text{DeltaPocMsbCycleLt}[i - 1] \end{aligned} \quad (7-52)$$

slice_temporal_mvp_enabled_flag specifies whether temporal motion vector predictors can be used for inter prediction. If **slice_temporal_mvp_enabled_flag** is equal to 0, the syntax elements of the current picture shall be constrained such that no temporal motion vector predictor is used in decoding of the current picture. Otherwise (**slice_temporal_mvp_enabled_flag** is equal to 1), temporal motion vector predictors may be used in decoding of the current picture. When not present, the value of **slice_temporal_mvp_enabled_flag** is inferred to be equal to 0.

Let **currLayerId** be equal to **nuh_layer_id** of the current NAL unit. When both **slice_temporal_mvp_enabled_flag** and **TemporalId** are equal to 0, the syntax elements for all coded pictures with **nuh_layer_id** equal to **currLayerId** that follow the current picture in decoding order shall be constrained such that no temporal motion vector from any picture with **nuh_layer_id** equal to **currLayerId** that precedes the current picture in decoding order is used in decoding of any coded picture that follows the current picture in decoding order.

NOTE 3 When **slice_temporal_mvp_enabled_flag** is equal to 0 in an I slice, it has no impact on the normative decoding process of the picture but merely expresses a bitstream constraint.

NOTE 4 When **slice_temporal_mvp_enabled_flag** is equal to 0 in a slice with **TemporalId** equal to 0, decoders can empty “motion vector storage” for all reference pictures with **nuh_layer_id** equal to **currLayerId** in the decoded picture buffer.

slice_sao_luma_flag equal to 1 specifies that SAO is enabled for the luma component in the current slice; **slice_sao_luma_flag** equal to 0 specifies that SAO is disabled for the luma component in the current slice. When **slice_sao_luma_flag** is not present, it is inferred to be equal to 0.

slice_sao_chroma_flag equal to 1 specifies that SAO is enabled for the chroma component in the current slice; **slice_sao_chroma_flag** equal to 0 specifies that SAO is disabled for the chroma component in the current slice. When **slice_sao_chroma_flag** is not present, it is inferred to be equal to 0.

num_ref_idx_active_override_flag equal to 1 specifies that the syntax element **num_ref_idx_l0_active_minus1** is present for P and B slices and that the syntax element **num_ref_idx_l1_active_minus1** is present for B slices. **num_ref_idx_active_override_flag** equal to 0 specifies that the syntax elements **num_ref_idx_l0_active_minus1** and **num_ref_idx_l1_active_minus1** are not present.

num_ref_idx_l0_active_minus1 specifies the maximum reference index for reference picture list 0 that may be used to decode the slice. num_ref_idx_l0_active_minus1 shall be in the range of 0 to 14, inclusive. When the current slice is a P or B slice and num_ref_idx_l0_active_minus1 is not present, num_ref_idx_l0_active_minus1 is inferred to be equal to num_ref_idx_l0_default_active_minus1.

num_ref_idx_l1_active_minus1 specifies the maximum reference index for reference picture list 1 that may be used to decode the slice. num_ref_idx_l1_active_minus1 shall be in the range of 0 to 14, inclusive. When num_ref_idx_l1_active_minus1 is not present, num_ref_idx_l1_active_minus1 is inferred to be equal to num_ref_idx_l1_default_active_minus1.

mvd_l1_zero_flag equal to 1 indicates that the mvd_coding(x0, y0, 1) syntax structure is not parsed and MvdL1[x0][y0][compIdx] is set equal to 0 for compIdx = 0..1. mvd_l1_zero_flag equal to 0 indicates that the mvd_coding(x0, y0, 1) syntax structure is parsed.

cabac_init_flag specifies the method for determining the initialization table used in the initialization process for context variables. When cabac_init_flag is not present, it is inferred to be equal to 0.

collocated_from_l0_flag equal to 1 specifies that the collocated picture used for temporal motion vector prediction is derived from reference picture list 0. collocated_from_l0_flag equal to 0 specifies that the collocated picture used for temporal motion vector prediction is derived from reference picture list 1. When collocated_from_l0_flag is not present, it is inferred to be equal to 1.

collocated_ref_idx specifies the reference index of the collocated picture used for temporal motion vector prediction.

When slice_type is equal to P or when slice_type is equal to B and collocated_from_l0_flag is equal to 1, collocated_ref_idx refers to a picture in list 0, and the value of collocated_ref_idx shall be in the range of 0 to num_ref_idx_l0_active_minus1, inclusive.

When slice_type is equal to B and collocated_from_l0_flag is equal to 0, collocated_ref_idx refers to a picture in list 1, and the value of collocated_ref_idx shall be in the range of 0 to num_ref_idx_l1_active_minus1, inclusive.

When collocated_ref_idx is not present, the value of collocated_ref_idx is inferred to be equal to 0.

When slice_temporal_mvp_enabled_flag is equal to 1, it is a requirement of bitstream conformance that, for all slices of the current picture that have slice_type not equal to 2 (if any), the picture referred to by collocated_ref_idx shall be the same and shall not be the current picture.

NOTE 5 This implies that when pps_curr_pic_ref_enabled_flag is equal to 1 and the current picture is the only reference picture in the reference picture list, slice_temporal_mvp_enabled_flag would be constrained to be equal to 0.

five_minus_max_num_merge_cand specifies the maximum number of merging MVP candidates supported in the slice subtracted from 5. The maximum number of merging MVP candidates, MaxNumMergeCand is derived as follows:

$$\text{MaxNumMergeCand} = 5 - \text{five_minus_max_num_merge_cand} \quad (7-53)$$

The value of MaxNumMergeCand shall be in the range of 1 to 5, inclusive.

use_integer_mv_flag equal to 1 specifies that the resolution of motion vectors for inter prediction in the current slice is integer. use_integer_mv_flag equal to 0 specifies that the resolution of motion vectors for inter prediction in the current slice that refer to pictures other than the current picture is fractional with quarter-sample precision in units of luma samples. When not present, the value of use_integer_mv_flag is inferred to be equal to motion_vector_resolution_control_idc.

slice_qp_delta specifies the initial value of Qp_Y to be used for the coding blocks in the slice until modified by the value of CuQpDeltaVal in the coding unit layer. The initial value of the Qp_Y quantization parameter for the slice, SliceQp_Y, is derived as follows:

$$\text{SliceQp}_Y = 26 + \text{init_qp_minus26} + \text{slice_qp_delta} \quad (7-54)$$

The value of SliceQp_Y shall be in the range of $-\text{QpBdOffset}_Y$ to +51, inclusive.

slice_cb_qp_offset specifies a difference to be added to the value of pps_cb_qp_offset when determining the value of the Qp'_{cb} quantization parameter. The value of $\text{slice_cb_qp_offset}$ shall be in the range of -12 to +12, inclusive. When $\text{slice_cb_qp_offset}$ is not present, it is inferred to be equal to 0. The value of $\text{pps_cb_qp_offset} + \text{slice_cb_qp_offset}$ shall be in the range of -12 to +12, inclusive.

slice_cr_qp_offset specifies a difference to be added to the value of pps_cr_qp_offset when determining the value of the Qp'_{cr} quantization parameter. The value of $\text{slice_cr_qp_offset}$ shall be in the range of -12 to +12, inclusive. When $\text{slice_cr_qp_offset}$ is not present, it is inferred to be equal to 0. The value of $\text{pps_cr_qp_offset} + \text{slice_cr_qp_offset}$ shall be in the range of -12 to +12, inclusive.

slice_act_y_qp_offset, **slice_act_cb_qp_offset** and **slice_act_cr_qp_offset** specify offsets to the quantization parameter values qP derived in 8.6.2 for luma, Cb, and Cr components, respectively. The values of $\text{slice_act_y_qp_offset}$, $\text{slice_act_cb_qp_offset}$ and $\text{slice_act_cr_qp_offset}$ shall be in the range of -12 to +12, inclusive. When not present, the values of $\text{slice_act_y_qp_offset}$, $\text{slice_act_cb_qp_offset}$, and $\text{slice_act_cr_qp_offset}$ are inferred to be equal to 0. The value of $\text{PpsActQpOffset}_Y + \text{slice_act_y_qp_offset}$ shall be in the range of -12 to +12, inclusive. The value of $\text{PpsActQpOffset}_{Cb} + \text{slice_act_cb_qp_offset}$ shall be in the range of -12 to +12, inclusive. The value of $\text{PpsActQpOffset}_{Cr} + \text{slice_act_cr_qp_offset}$ shall be in the range of -12 to +12, inclusive.

cu_chroma_qp_offset_enabled_flag equal to 1 specifies that the $\text{cu_chroma_qp_offset_flag}$ may be present in the transform unit syntax. $\text{cu_chroma_qp_offset_flag}$ equal to 0 specifies that the $\text{cu_chroma_qp_offset_flag}$ is not present in the transform unit syntax. When not present, the value of $\text{cu_chroma_qp_offset_enabled_flag}$ is inferred to be equal to 0.

deblocking_filter_override_flag equal to 1 specifies that deblocking parameters are present in the slice header. $\text{deblocking_filter_override_flag}$ equal to 0 specifies that deblocking parameters are not present in the slice header. When not present, the value of $\text{deblocking_filter_override_flag}$ is inferred to be equal to 0.

slice_deblocking_filter_disabled_flag equal to 1 specifies that the operation of the deblocking filter is not applied for the current slice. $\text{slice_deblocking_filter_disabled_flag}$ equal to 0 specifies that the operation of the deblocking filter is applied for the current slice. When $\text{slice_deblocking_filter_disabled_flag}$ is not present, it is inferred to be equal to $\text{pps_deblocking_filter_disabled_flag}$.

slice_beta_offset_div2 and **slice_tc_offset_div2** specify the deblocking parameter offsets for β and tC (divided by 2) for the current slice. The values of $\text{slice_beta_offset_div2}$ and $\text{slice_tc_offset_div2}$ shall both be in the range of -6 to 6, inclusive. When not present, the values of $\text{slice_beta_offset_div2}$ and $\text{slice_tc_offset_div2}$ are inferred to be equal to $\text{pps_beta_offset_div2}$ and $\text{pps_tc_offset_div2}$, respectively.

slice_loop_filter_across_slices_enabled_flag equal to 1 specifies that in-loop filtering operations may be performed across the left and upper boundaries of the current slice. $\text{slice_loop_filter_across_slices_enabled_flag}$ equal to 0 specifies that in-loop operations are not performed across left and upper boundaries of the current slice. The in-loop filtering operations include the deblocking filter and sample adaptive offset filter. When $\text{slice_loop_filter_across_slices_enabled_flag}$ is not present, it is inferred to be equal to $\text{pps_loop_filter_across_slices_enabled_flag}$.

num_entry_point_offsets specifies the number of $\text{entry_point_offset_minus1}[i]$ syntax elements in the slice header. When not present, the value of $\text{num_entry_point_offsets}$ is inferred to be equal to 0.

The value of $\text{num_entry_point_offsets}$ is constrained as follows:

- If $\text{tiles_enabled_flag}$ is equal to 0 and $\text{entropy_coding_sync_enabled_flag}$ is equal to 1, the value of $\text{num_entry_point_offsets}$ shall be in the range of 0 to $\text{PicHeightInCtbs}_Y - 1$, inclusive.
- Otherwise, if $\text{tiles_enabled_flag}$ is equal to 1 and $\text{entropy_coding_sync_enabled_flag}$ is equal to 0, the value of $\text{num_entry_point_offsets}$ shall be in the range of 0 to $(\text{num_tile_columns_minus1} + 1) * (\text{num_tile_rows_minus1} + 1) - 1$, inclusive.

— Otherwise, when `tiles_enabled_flag` is equal to 1 and `entropy_coding_sync_enabled_flag` is equal to 1, the value of `num_entry_point_offsets` shall be in the range of 0 to $(\text{num_tile_columns_minus1} + 1) * \text{PicHeightInCtbsY} - 1$, inclusive.

offset_len_minus1 plus 1 specifies the length, in bits, of the `entry_point_offset_minus1[i]` syntax elements. The value of `offset_len_minus1` shall be in the range of 0 to 31, inclusive.

entry_point_offset_minus1[i] plus 1 specifies the *i*-th entry point offset in bytes, and is represented by `offset_len_minus1` plus 1 bits. The slice segment data that follow the slice segment header consists of `num_entry_point_offsets` + 1 subsets, with subset index values ranging from 0 to `num_entry_point_offsets`, inclusive. The first byte of the slice segment data is considered byte 0. When present, emulation prevention bytes that appear in the slice segment data portion of the coded slice segment NAL unit are counted as part of the slice segment data for purposes of subset identification. Subset 0 consists of bytes 0 to `entry_point_offset_minus1[0]`, inclusive, of the coded slice segment data, subset *k*, with *k* in the range of 1 to `num_entry_point_offsets` - 1, inclusive, consists of bytes `firstByte[k]` to `lastByte[k]`, inclusive, of the coded slice segment data with `firstByte[k]` and `lastByte[k]` defined as:

$$\text{firstByte}[k] = \sum_{n=1}^k (\text{entry_point_offset_minus1}[n - 1] + 1) \quad (7-55)$$

$$\text{lastByte}[k] = \text{firstByte}[k] + \text{entry_point_offset_minus1}[k] \quad (7-56)$$

The last subset (with subset index equal to `num_entry_point_offsets`) consists of the remaining bytes of the coded slice segment data.

When `tiles_enabled_flag` is equal to 1 and `entropy_coding_sync_enabled_flag` is equal to 0, each subset shall consist of all coded bits of all coding tree units in the slice segment that are within the same tile, and the number of subsets (i.e. the value of `num_entry_point_offsets` + 1) shall be equal to the number of tiles that contain coding tree units that are in the coded slice segment.

NOTE 6 When `tiles_enabled_flag` is equal to 1 and `entropy_coding_sync_enabled_flag` is equal to 0, each slice needs to include either a subset of the coding tree units of one tile (in which case the syntax element `entry_point_offset_minus1[i]` is not present) or all coding tree units of an integer number of complete tiles.

When `tiles_enabled_flag` is equal to 0 and `entropy_coding_sync_enabled_flag` is equal to 1, each subset *k* with *k* in the range of 0 to `num_entry_point_offsets`, inclusive, shall consist of all coded bits of all coding tree units in the slice segment that include luma coding tree blocks that are in the same luma coding tree block row of the picture, and the number of subsets (i.e. the value of `num_entry_point_offsets` + 1) shall be equal to the number of coding tree block rows of the picture that contain coding tree units that are in the coded slice segment.

NOTE 7 The last subset (i.e. subset *k* for *k* equal to `num_entry_point_offsets`) may or may not contain all coding tree units that include luma coding tree blocks that are in a luma coding tree block row of the picture.

When `tiles_enabled_flag` is equal to 1 and `entropy_coding_sync_enabled_flag` is equal to 1, each subset *k* with *k* in the range of 0 to `num_entry_point_offsets`, inclusive, shall consist of all coded bits of all coding tree units in the slice segment that include luma coding tree blocks that are in the same luma coding tree block row within a tile, and the number of subsets (i.e. the value of `num_entry_point_offsets` + 1) shall be equal to the number of luma coding tree block row scans in the tile scan for the coding tree units of the coded slice segment.

slice_segment_header_extension_length specifies the length of the slice segment header extension data in bytes, not including the bits used for signalling `slice_segment_header_extension_length` itself. The value of `slice_segment_header_extension_length` shall be in the range of 0 to 256, inclusive. When not present, the value of `slice_segment_header_extension_length` is inferred to be equal to 0.

slice_segment_header_extension_data_byte may have any value. Decoders shall ignore the value of **slice_segment_header_extension_data_byte**. Its value does not affect decoder conformance to profiles specified in Annex A.

7.4.7.2 Reference picture list modification semantics

ref_pic_list_modification_flag_l0 equal to 1 indicates that reference picture list 0 is specified explicitly by a list of **list_entry_l0[i]** values. **ref_pic_list_modification_flag_l0** equal to 0 indicates that reference picture list 0 is determined implicitly. When **ref_pic_list_modification_flag_l0** is not present in the slice header, it is inferred to be equal to 0.

list_entry_l0[i] specifies the index of the reference picture in **RefPicListTemp0** to be placed at the current position of reference picture list 0. The length of the **list_entry_l0[i]** syntax element is $\text{Ceil}(\text{Log}_2(\text{NumPicTotalCurr}))$ bits. The value of **list_entry_l0[i]** shall be in the range of 0 to $\text{NumPicTotalCurr} - 1$, inclusive. When the syntax element **list_entry_l0[i]** is not present in the slice header, it is inferred to be equal to 0.

The variable **NumPicTotalCurr** is derived as follows:

```

NumPicTotalCurr = 0
for( i = 0; i < NumNegativePics[ CurrRpsIdx ]; i++ )
    if( UsedByCurrPicS0[ CurrRpsIdx ][ i ] )
        NumPicTotalCurr++
for( i = 0; i < NumPositivePics[ CurrRpsIdx ]; i++ )
    if( UsedByCurrPicS1[ CurrRpsIdx ][ i ] )
        NumPicTotalCurr++
for( i = 0; i < num_long_term_sps + num_long_term_pics; i++ )
    if( UsedByCurrPicLt[ i ] )
        NumPicTotalCurr++
if( pps_curr_pic_ref_enabled_flag )
    NumPicTotalCurr++

```

(7-57)

ref_pic_list_modification_flag_l1 equal to 1 indicates that reference picture list 1 is specified explicitly by a list of **list_entry_l1[i]** values. **ref_pic_list_modification_flag_l1** equal to 0 indicates that reference picture list 1 is determined implicitly. When **ref_pic_list_modification_flag_l1** is not present in the slice header, it is inferred to be equal to 0.

list_entry_l1[i] specifies the index of the reference picture in **RefPicListTemp1** to be placed at the current position of reference picture list 1. The length of the **list_entry_l1[i]** syntax element is $\text{Ceil}(\text{Log}_2(\text{NumPicTotalCurr}))$ bits. The value of **list_entry_l1[i]** shall be in the range of 0 to $\text{NumPicTotalCurr} - 1$, inclusive. When the syntax element **list_entry_l1[i]** is not present in the slice header, it is inferred to be equal to 0.

7.4.7.3 Weighted prediction parameters semantics

luma_log2_weight_denom is the base 2 logarithm of the denominator for all luma weighting factors. The value of **luma_log2_weight_denom** shall be in the range of 0 to 7, inclusive.

delta_chroma_log2_weight_denom is the difference of the base 2 logarithm of the denominator for all chroma weighting factors. When **delta_chroma_log2_weight_denom** is not present, it is inferred to be equal to 0.

The variable **ChromaLog2WeightDenom** is derived to be equal to **luma_log2_weight_denom** + **delta_chroma_log2_weight_denom**, and the value shall be in the range of 0 to 7, inclusive.

luma_weight_l0_flag[i] equal to 1 specifies that weighting factors for the luma component of list 0 prediction using **RefPicList0[i]** are present. **luma_weight_l0_flag[i]** equal to 0 specifies that these weighting factors are not present. When **luma_weight_l0_flag[i]** is not present, it is inferred to be equal to 0.

chroma_weight_l0_flag[i] equal to 1 specifies that weighting factors for the chroma prediction values of list 0 prediction using RefPicList0[i] are present. chroma_weight_l0_flag[i] equal to 0 specifies that these weighting factors are not present. When chroma_weight_l0_flag[i] is not present, it is inferred to be equal to 0.

delta_luma_weight_l0[i] is the difference of the weighting factor applied to the luma prediction value for list 0 prediction using RefPicList0[i].

The variable LumaWeightL0[i] is derived to be equal to $(1 \ll \text{luma_log2_weight_denom}) + \text{delta_luma_weight_l0}[i]$. When luma_weight_l0_flag[i] is equal to 1, the value of delta_luma_weight_l0[i] shall be in the range of -128 to 127, inclusive. When luma_weight_l0_flag[i] is equal to 0, LumaWeightL0[i] is inferred to be equal to $2^{\text{luma_log2_weight_denom}}$.

luma_offset_l0[i] is the additive offset applied to the luma prediction value for list 0 prediction using RefPicList0[i]. The value of luma_offset_l0[i] shall be in the range of -WpOffsetHalfRange_v to WpOffsetHalfRange_v - 1, inclusive. When luma_weight_l0_flag[i] is equal to 0, luma_offset_l0[i] is inferred to be equal to 0.

delta_chroma_weight_l0[i][j] is the difference of the weighting factor applied to the chroma prediction values for list 0 prediction using RefPicList0[i] with j equal to 0 for Cb and j equal to 1 for Cr.

The variable ChromaWeightL0[i][j] is derived to be equal to $(1 \ll \text{ChromaLog2WeightDenom}) + \text{delta_chroma_weight_l0}[i][j]$. When chroma_weight_l0_flag[i] is equal to 1, the value of delta_chroma_weight_l0[i][j] shall be in the range of -128 to 127, inclusive. When chroma_weight_l0_flag[i] is equal to 0, ChromaWeightL0[i][j] is inferred to be equal to $2^{\text{ChromaLog2WeightDenom}}$.

delta_chroma_offset_l0[i][j] is the difference of the additive offset applied to the chroma prediction values for list 0 prediction using RefPicList0[i] with j equal to 0 for Cb and j equal to 1 for Cr.

The variable ChromaOffsetL0[i][j] is derived as follows:

$$\begin{aligned} \text{ChromaOffsetL0}[i][j] = & \text{Clip3}(-\text{WpOffsetHalfRange}_c, \text{WpOffsetHalfRange}_c - 1, \\ & (\text{WpOffsetHalfRange}_c + \text{delta_chroma_offset_l0}[i][j] - \\ & ((\text{WpOffsetHalfRange}_c * \text{ChromaWeightL0}[i][j]) \gg \text{ChromaLog2WeightDenom}))) \end{aligned} \quad (7-58)$$

The value of delta_chroma_offset_l0[i][j] shall be in the range of $-4 * \text{WpOffsetHalfRange}_c$ to $4 * \text{WpOffsetHalfRange}_c - 1$, inclusive. When chroma_weight_l0_flag[i] is equal to 0, ChromaOffsetL0[i][j] is inferred to be equal to 0.

luma_weight_l1_flag[i], **chroma_weight_l1_flag**[i], **delta_luma_weight_l1**[i], **luma_offset_l1**[i], **delta_chroma_weight_l1**[i][j], and **delta_chroma_offset_l1**[i][j] have the same semantics as luma_weight_l0_flag[i], chroma_weight_l0_flag[i], delta_luma_weight_l0[i], luma_offset_l0[i], delta_chroma_weight_l0[i][j], and delta_chroma_offset_l0[i][j], respectively, with l0, L0, list 0, and List0 replaced by l1, L1, list 1, and List1, respectively.

The variable sumWeightL0Flags is derived to be equal to the sum of luma_weight_l0_flag[i] + 2 * chroma_weight_l0_flag[i], for i = 0..num_ref_idx_l0_active_minus1.

When slice_type is equal to B, the variable sumWeightL1Flags is derived to be equal to the sum of luma_weight_l1_flag[i] + 2 * chroma_weight_l1_flag[i], for i = 0..num_ref_idx_l1_active_minus1.

It is a requirement of bitstream conformance that, when slice_type is equal to P, sumWeightL0Flags shall be less than or equal to 24, and when slice_type is equal to B, the sum of sumWeightL0Flags and sumWeightL1Flags shall be less than or equal to 24.

7.4.8 Short-term reference picture set semantics

The st_ref_pic_set(stRpsIdx) syntax structure may be present in an SPS or in a slice header. Depending on whether the syntax structure is included in a slice header or an SPS, the following apply:

- If present in a slice header, the `st_ref_pic_set(stRpsIdx)` syntax structure specifies the short-term RPS of the current picture (the picture containing the slice), and the following apply:
 - The content of the `st_ref_pic_set(stRpsIdx)` syntax structure shall be the same in all slice headers of the current picture.
 - The value of `stRpsIdx` shall be equal to the syntax element `num_short_term_ref_pic_sets` in the active SPS.
 - The short-term RPS of the current picture is also referred to as the `num_short_term_ref_pic_sets`-th candidate short-term RPS in the semantics specified in the remainder of this subclause.
- Otherwise (present in an SPS), the `st_ref_pic_set(stRpsIdx)` syntax structure specifies a candidate short-term RPS, and the term "the current picture" in the semantics specified in the remainder of this subclause refers to each picture that has `short_term_ref_pic_set_idx` equal to `stRpsIdx` in a CVS that has the SPS as the active SPS.

inter_ref_pic_set_prediction_flag equal to 1 specifies that the `stRpsIdx`-th candidate short-term RPS is predicted from another candidate short-term RPS, which is referred to as the source candidate short-term RPS. When `inter_ref_pic_set_prediction_flag` is not present, it is inferred to be equal to 0.

delta_idx_minus1 plus 1 specifies the difference between the value of `stRpsIdx` and the index, into the list of the candidate short-term RPSs specified in the SPS, of the source candidate short-term RPS. The value of `delta_idx_minus1` shall be in the range of 0 to `stRpsIdx - 1`, inclusive. When `delta_idx_minus1` is not present, it is inferred to be equal to 0.

The variable `RefRpsIdx` is derived as follows:

$$\text{RefRpsIdx} = \text{stRpsIdx} - (\text{delta_idx_minus1} + 1) \quad (7-59)$$

delta_rps_sign and **abs_delta_rps_minus1** together specify the value of the variable `deltaRps` as follows:

$$\text{deltaRps} = (1 - 2 * \text{delta_rps_sign}) * (\text{abs_delta_rps_minus1} + 1) \quad (7-60)$$

The variable `deltaRps` represents the value to be added to the picture order count difference values of the source candidate short-term RPS to obtain the picture order count difference values of the `stRpsIdx`-th candidate short-term RPS. The value of `abs_delta_rps_minus1` shall be in the range of 0 to $2^{15} - 1$, inclusive.

used_by_curr_pic_flag[j] equal to 0 specifies that the `j`-th entry in the source candidate short-term RPS is not used for reference by the current picture.

use_delta_flag[j] equal to 1 specifies that the `j`-th entry in the source candidate short-term RPS is included in the `stRpsIdx`-th candidate short-term RPS. **use_delta_flag[j]** equal to 0 specifies that the `j`-th entry in the source candidate short-term RPS is not included in the `stRpsIdx`-th candidate short-term RPS. When **use_delta_flag[j]** is not present, its value is inferred to be equal to 1.

When `inter_ref_pic_set_prediction_flag` is equal to 1, the variables `DeltaPocS0[stRpsIdx][i]`, `UsedByCurrPicS0[stRpsIdx][i]`, `NumNegativePics[stRpsIdx]`, `DeltaPocS1[stRpsIdx][i]`, `UsedByCurrPicS1[stRpsIdx][i]`, and `NumPositivePics[stRpsIdx]` are derived as follows:

```
i = 0
for( j = NumPositivePics[ RefRpsIdx ] - 1; j >= 0; j-- ) {
    dPoc = DeltaPocS1[ RefRpsIdx ][ j ] + deltaRps
    if( dPoc < 0 && use_delta_flag[ NumNegativePics[ RefRpsIdx ] + j ] ) {
        DeltaPocS0[ stRpsIdx ][ i ] = dPoc
        UsedByCurrPicS0[ stRpsIdx ][ i++ ] =
        used_by_curr_pic_flag[ NumNegativePics[ RefRpsIdx ] + j ]
    }
}
```

```

    }
}
if( deltaRps < 0 && use_delta_flag[ NumDeltaPocs[ RefRpsIdx ] ] ) {
    DeltaPocS0[ stRpsIdx ][ i ] = deltaRps
    UsedByCurrPicS0[ stRpsIdx ][ i++ ] = used_by_curr_pic_flag[ NumDeltaPocs[ RefRpsIdx ] ]
}
for( j = 0; j < NumNegativePics[ RefRpsIdx ]; j++ ) {
    dPoc = DeltaPocS0[ RefRpsIdx ][ j ] + deltaRps
    if( dPoc < 0 && use_delta_flag[ j ] ) {
        DeltaPocS0[ stRpsIdx ][ i ] = dPoc
        UsedByCurrPicS0[ stRpsIdx ][ i++ ] = used_by_curr_pic_flag[ j ]
    }
}
}
NumNegativePics[ stRpsIdx ] = i

```

```

i = 0
for( j = NumNegativePics[ RefRpsIdx ] - 1; j >= 0; j-- ) {
    dPoc = DeltaPocS0[ RefRpsIdx ][ j ] + deltaRps
    if( dPoc > 0 && use_delta_flag[ j ] ) {
        DeltaPocS1[ stRpsIdx ][ i ] = dPoc
        UsedByCurrPicS1[ stRpsIdx ][ i++ ] = used_by_curr_pic_flag[ j ]
    }
}
if( deltaRps > 0 && use_delta_flag[ NumDeltaPocs[ RefRpsIdx ] ] ) {
    DeltaPocS1[ stRpsIdx ][ i ] = deltaRps
    UsedByCurrPicS1[ stRpsIdx ][ i++ ] = used_by_curr_pic_flag[ NumDeltaPocs[ RefRpsIdx ] ]
}
for( j = 0; j < NumPositivePics[ RefRpsIdx ]; j++ ) {
    dPoc = DeltaPocS1[ RefRpsIdx ][ j ] + deltaRps
    if( dPoc > 0 && use_delta_flag[ NumNegativePics[ RefRpsIdx ] + j ] ) {
        DeltaPocS1[ stRpsIdx ][ i ] = dPoc
        UsedByCurrPicS1[ stRpsIdx ][ i++ ] =
used_by_curr_pic_flag[ NumNegativePics[ RefRpsIdx ] + j ]
    }
}
}
NumPositivePics[ stRpsIdx ] = i

```

num_negative_pics specifies the number of entries in the stRpsIdx-th candidate short-term RPS that have picture order count values less than the picture order count value of the current picture. When nuh_layer_id of the current picture is equal to 0, the value of num_negative_pics shall be in the range of 0 to sps_max_dec_pic_buffering_minus1[sps_max_sub_layers_minus1], inclusive.

num_positive_pics specifies the number of entries in the stRpsIdx-th candidate short-term RPS that have picture order count values greater than the picture order count value of the current picture. When nuh_layer_id of the current picture is equal to 0, the value of num_positive_pics shall be in the range of 0 to sps_max_dec_pic_buffering_minus1[sps_max_sub_layers_minus1] - num_negative_pics, inclusive.

delta_poc_s0_minus1[i] plus 1, when i is equal to 0, specifies the difference between the picture order count values of the current picture and i-th entry in the stRpsIdx-th candidate short-term RPS that has picture order count value less than that of the current picture, or, when i is greater than 0, specifies the difference between the picture order count values of the (i - 1)-th entry and the i-th entry in the stRpsIdx-th candidate short-term RPS that have picture order count values less than the picture order count value of the current picture. The value of delta_poc_s0_minus1[i] shall be in the range of 0 to 2¹⁵ - 1, inclusive.

used_by_curr_pic_s0_flag[*i*] equal to 0 specifies that the *i*-th entry in the *stRpsIdx*-th candidate short-term RPS that has picture order count value less than that of the current picture is not used for reference by the current picture.

delta_poc_s1_minus1[*i*] plus 1, when *i* is equal to 0, specifies the difference between the picture order count values of the current picture and the *i*-th entry in the *stRpsIdx*-th candidate short-term RPS that has picture order count value greater than that of the current picture, or, when *i* is greater than 0, specifies the difference between the picture order count values of the *i*-th entry and the (*i* - 1)-th entry in the current candidate short-term RPS that have picture order count values greater than the picture order count value of the current picture. The value of **delta_poc_s1_minus1**[*i*] shall be in the range of 0 to $2^{15} - 1$, inclusive.

used_by_curr_pic_s1_flag[*i*] equal to 0 specifies that the *i*-th entry in the current candidate short-term RPS that has picture order count value greater than that of the current picture is not used for reference by the current picture.

When **inter_ref_pic_set_prediction_flag** is equal to 0, the variables **NumNegativePics**[*stRpsIdx*], **NumPositivePics**[*stRpsIdx*], **UsedByCurrPicS0**[*stRpsIdx*][*i*], **UsedByCurrPicS1**[*stRpsIdx*][*i*], **DeltaPocS0**[*stRpsIdx*][*i*], and **DeltaPocS1**[*stRpsIdx*][*i*] are derived as follows:

$$\text{NumNegativePics}[\text{stRpsIdx}] = \text{num_negative_pics} \quad (7-63)$$

$$\text{NumPositivePics}[\text{stRpsIdx}] = \text{num_positive_pics} \quad (7-64)$$

$$\text{UsedByCurrPicS0}[\text{stRpsIdx}][i] = \text{used_by_curr_pic_s0_flag}[i] \quad (7-65)$$

$$\text{UsedByCurrPicS1}[\text{stRpsIdx}][i] = \text{used_by_curr_pic_s1_flag}[i] \quad (7-66)$$

— If *i* is equal to 0, the following apply:

$$\text{DeltaPocS0}[\text{stRpsIdx}][i] = -(\text{delta_poc_s0_minus1}[i] + 1) \quad (7-67)$$

$$\text{DeltaPocS1}[\text{stRpsIdx}][i] = \text{delta_poc_s1_minus1}[i] + 1 \quad (7-68)$$

— Otherwise, the following apply:

$$\text{DeltaPocS0}[\text{stRpsIdx}][i] = \text{DeltaPocS0}[\text{stRpsIdx}][i - 1] - (\text{delta_poc_s0_minus1}[i] + 1) \quad (7-69)$$

$$\text{DeltaPocS1}[\text{stRpsIdx}][i] = \text{DeltaPocS1}[\text{stRpsIdx}][i - 1] + (\text{delta_poc_s1_minus1}[i] + 1) \quad (7-70)$$

The variable **NumDeltaPocs**[*stRpsIdx*] is derived as follows:

$$\text{NumDeltaPocs}[\text{stRpsIdx}] = \text{NumNegativePics}[\text{stRpsIdx}] + \text{NumPositivePics}[\text{stRpsIdx}] \quad (7-71)$$

7.4.9 Slice segment data semantics

7.4.9.1 General slice segment data semantics

end_of_slice_segment_flag equal to 0 specifies that another coding tree unit is following in the slice. **end_of_slice_segment_flag** equal to 1 specifies the end of the slice segment, i.e. that no further coding tree unit follows in the slice segment.

end_of_subset_one_bit shall be equal to 1.

7.4.9.2 Coding tree unit semantics

The coding tree unit is the root node of the coding quadtree structure.

7.4.9.3 Sample adaptive offset semantics

sao_merge_left_flag equal to 1 specifies that the syntax elements `sao_type_idx_luma`, `sao_type_idx_chroma`, `sao_band_position`, `sao_eo_class_luma`, `sao_eo_class_chroma`, `sao_offset_abs`, and `sao_offset_sign` are derived from the corresponding syntax elements of the left coding tree block. `sao_merge_left_flag` equal to 0 specifies that these syntax elements are not derived from the corresponding syntax elements of the left coding tree block. When `sao_merge_left_flag` is not present, it is inferred to be equal to 0.

sao_merge_up_flag equal to 1 specifies that the syntax elements `sao_type_idx_luma`, `sao_type_idx_chroma`, `sao_band_position`, `sao_eo_class_luma`, `sao_eo_class_chroma`, `sao_offset_abs`, and `sao_offset_sign` are derived from the corresponding syntax elements of the above coding tree block. `sao_merge_up_flag` equal to 0 specifies that these syntax elements are not derived from the corresponding syntax elements of the above coding tree block. When `sao_merge_up_flag` is not present, it is inferred to be equal to 0.

sao_type_idx_luma specifies the offset type for the luma component. The array `SaoTypeIdx[cldx][rx][ry]` specifies the offset type as specified in Table 7-8 for the coding tree block at the location (`rx`, `ry`) for the colour component `cldx`. The value of `SaoTypeIdx[0][rx][ry]` is derived as follows:

- If `sao_type_idx_luma` is present, `SaoTypeIdx[0][rx][ry]` is set equal to `sao_type_idx_luma`.
- Otherwise (`sao_type_idx_luma` is not present), `SaoTypeIdx[0][rx][ry]` is derived as follows:
 - If `sao_merge_left_flag` is equal to 1, `SaoTypeIdx[0][rx][ry]` is set equal to `SaoTypeIdx[0][rx - 1][ry]`.
 - Otherwise, if `sao_merge_up_flag` is equal to 1, `SaoTypeIdx[0][rx][ry]` is set equal to `SaoTypeIdx[0][rx][ry - 1]`.
 - Otherwise, `SaoTypeIdx[0][rx][ry]` is set equal to 0.

sao_type_idx_chroma specifies the offset type for the chroma components. The values of `SaoTypeIdx[cldx][rx][ry]` are derived as follows for `cldx` equal to 1..2:

- If `sao_type_idx_chroma` is present, `SaoTypeIdx[cldx][rx][ry]` is set equal to `sao_type_idx_chroma`.
- Otherwise (`sao_type_idx_chroma` is not present), `SaoTypeIdx[cldx][rx][ry]` is derived as follows:
 - If `sao_merge_left_flag` is equal to 1, `SaoTypeIdx[cldx][rx][ry]` is set equal to `SaoTypeIdx[cldx][rx - 1][ry]`.
 - Otherwise, if `sao_merge_up_flag` is equal to 1, `SaoTypeIdx[cldx][rx][ry]` is set equal to `SaoTypeIdx[cldx][rx][ry - 1]`.
 - Otherwise, `SaoTypeIdx[cldx][rx][ry]` is set equal to 0.

Table 7-8 — Specification of the SAO type

SaoTypeIdx[cldx][rx][ry]	SAO type (informative)
0	Not applied
1	Band offset
2	Edge offset

sao_offset_abs[cldx][rx][ry][i] specifies the offset value of `i`-th category for the coding tree block at the location (`rx`, `ry`) for the colour component `cldx`.

When $\text{sao_offset_abs}[cIdx][rx][ry][i]$ is not present, it is inferred as follows:

- If $\text{sao_merge_left_flag}$ is equal to 1, $\text{sao_offset_abs}[cIdx][rx][ry][i]$ is inferred to be equal to $\text{sao_offset_abs}[cIdx][rx-1][ry][i]$.
- Otherwise, if sao_merge_up_flag is equal to 1, $\text{sao_offset_abs}[cIdx][rx][ry][i]$ is inferred to be equal to $\text{sao_offset_abs}[cIdx][rx][ry-1][i]$.
- Otherwise, $\text{sao_offset_abs}[cIdx][rx][ry][i]$ is inferred to be equal to 0.

sao_offset_sign $[cIdx][rx][ry][i]$ specifies the sign of the offset value of i -th category for the coding tree block at the location (rx, ry) for the colour component $cIdx$.

When $\text{sao_offset_sign}[cIdx][rx][ry][i]$ is not present, it is inferred as follows:

- If $\text{sao_merge_left_flag}$ is equal to 1, $\text{sao_offset_sign}[cIdx][rx][ry][i]$ is inferred to be equal to $\text{sao_offset_sign}[cIdx][rx-1][ry][i]$.
- Otherwise, if sao_merge_up_flag is equal to 1, $\text{sao_offset_sign}[cIdx][rx][ry][i]$ is inferred to be equal to $\text{sao_offset_sign}[cIdx][rx][ry-1][i]$.
- Otherwise, if $\text{SaoTypeIdx}[cIdx][rx][ry]$ is equal to 2, the following apply:
 - If i is equal to 0 or 1, $\text{sao_offset_sign}[cIdx][rx][ry][i]$ is inferred to be equal 0.
 - Otherwise (i is equal to 2 or 3), $\text{sao_offset_sign}[cIdx][rx][ry][i]$ is inferred to be equal 1.
- Otherwise, $\text{sao_offset_sign}[cIdx][rx][ry][i]$ is inferred to be equal 0.

The variable log2OffsetScale is derived as follows:

- If $cIdx$ is equal to 0, log2OffsetScale is set equal to $\text{log2_sao_offset_scale_luma}$.
- Otherwise ($cIdx$ is equal to 1 or 2), log2OffsetScale is set equal to $\text{log2_sao_offset_scale_chroma}$.

The list $\text{SaoOffsetVal}[cIdx][rx][ry][i]$ for i ranging from 0 to 4, inclusive, is derived as follows:

$$\begin{aligned} \text{SaoOffsetVal}[cIdx][rx][ry][0] &= 0 \\ \text{for}(i = 0; i < 4; i++) \\ \text{SaoOffsetVal}[cIdx][rx][ry][i+1] &= (1 - 2 * \text{sao_offset_sign}[cIdx][rx][ry][i]) * \\ &\quad \text{sao_offset_abs}[cIdx][rx][ry][i] \ll \text{log2OffsetScale} \end{aligned} \quad (7-72)$$

sao_band_position $[cIdx][rx][ry]$ specifies the displacement of the band offset of the sample range when $\text{SaoTypeIdx}[cIdx][rx][ry]$ is equal to 1.

When $\text{sao_band_position}[cIdx][rx][ry]$ is not present, it is inferred as follows:

- If $\text{sao_merge_left_flag}$ is equal to 1, $\text{sao_band_position}[cIdx][rx][ry]$ is inferred to be equal to $\text{sao_band_position}[cIdx][rx-1][ry]$.
- Otherwise, if sao_merge_up_flag is equal to 1, $\text{sao_band_position}[cIdx][rx][ry]$ is inferred to be equal to $\text{sao_band_position}[cIdx][rx][ry-1]$.
- Otherwise, $\text{sao_band_position}[cIdx][rx][ry]$ is inferred to be equal to 0.

sao_eo_class_luma specifies the edge offset class for the luma component. The array $\text{SaoEoClass}[cIdx][rx][ry]$ specifies the offset type as specified in Table 7-9 for the coding tree block at the location (rx, ry) for the colour component $cIdx$. The value of $\text{SaoEoClass}[0][rx][ry]$ is derived as follows:

ISO/IEC 23008-2:2017(E)

- If `sao_eo_class_luma` is present, `SaoEoClass[0][rx][ry]` is set equal to `sao_eo_class_luma`.
- Otherwise (`sao_eo_class_luma` is not present), `SaoEoClass[0][rx][ry]` is derived as follows:
 - If `sao_merge_left_flag` is equal to 1, `SaoEoClass[0][rx][ry]` is set equal to `SaoEoClass[0][rx - 1][ry]`.
 - Otherwise, if `sao_merge_up_flag` is equal to 1, `SaoEoClass[0][rx][ry]` is set equal to `SaoEoClass[0][rx][ry - 1]`.
 - Otherwise, `SaoEoClass[0][rx][ry]` is set equal to 0.

sao_eo_class_chroma specifies the edge offset class for the chroma components. The values of `SaoEoClass[cIdx][rx][ry]` are derived as follows for `cIdx` equal to 1..2:

- If `sao_eo_class_chroma` is present, `SaoEoClass[cIdx][rx][ry]` is set equal to `sao_eo_class_chroma`.
- Otherwise (`sao_eo_class_chroma` is not present), `SaoEoClass[cIdx][rx][ry]` is derived as follows:
 - If `sao_merge_left_flag` is equal to 1, `SaoEoClass[cIdx][rx][ry]` is set equal to `SaoEoClass[cIdx][rx - 1][ry]`.
 - Otherwise, if `sao_merge_up_flag` is equal to 1, `SaoEoClass[cIdx][rx][ry]` is set equal to `SaoEoClass[cIdx][rx][ry - 1]`.
 - Otherwise, `SaoEoClass[cIdx][rx][ry]` is set equal to 0.

Table 7-9 — Specification of the SAO edge offset class

<code>SaoEoClass[cIdx][rx][ry]</code>	SAO edge offset class (informative)
0	1D 0-degree edge offset
1	1D 90-degree edge offset
2	1D 135-degree edge offset
3	1D 45-degree edge offset

7.4.9.4 Coding quadtree semantics

split_cu_flag[x0][y0] specifies whether a coding unit is split into coding units with half horizontal and vertical size. The array indices `x0`, `y0` specify the location (`x0`, `y0`) of the top-left luma sample of the considered coding block relative to the top-left luma sample of the picture.

When `split_cu_flag[x0][y0]` is not present, the following apply:

- If `log2CbSize` is greater than `MinCbLog2SizeY`, the value of `split_cu_flag[x0][y0]` is inferred to be equal to 1.
- Otherwise (`log2CbSize` is equal to `MinCbLog2SizeY`), the value of `split_cu_flag[x0][y0]` is inferred to be equal to 0.

The array `CtDepth[x][y]` specifies the coding tree depth for a luma coding block covering the location (`x`, `y`). When `split_cu_flag[x0][y0]` is equal to 0, `CtDepth[x][y]` is inferred to be equal to `cqtDepth` for `x = x0..x0 + nCbS - 1` and `y = y0..y0 + nCbS - 1`.

7.4.9.5 Coding unit semantics

cu_transquant_bypass_flag equal to 1 specifies that the scaling and transform process as specified in 8.6 and the in-loop filter process as specified in 8.7 are bypassed. When **cu_transquant_bypass_flag** is not present, it is inferred to be equal to 0.

cu_skip_flag[x_0][y_0] equal to 1 specifies that for the current coding unit, when decoding a P or B slice, no more syntax elements except the merging candidate index **merge_idx**[x_0][y_0] are parsed after **cu_skip_flag**[x_0][y_0]. **cu_skip_flag**[x_0][y_0] equal to 0 specifies that the coding unit is not skipped. The array indices x_0 , y_0 specify the location (x_0 , y_0) of the top-left luma sample of the considered coding block relative to the top-left luma sample of the picture.

When **cu_skip_flag**[x_0][y_0] is not present, it is inferred to be equal to 0.

pred_mode_flag equal to 0 specifies that the current coding unit is coded in inter prediction mode. **pred_mode_flag** equal to 1 specifies that the current coding unit is coded in intra prediction mode. The variable **CuPredMode**[x][y] is derived as follows for $x = x_0..x_0 + nCbS - 1$ and $y = y_0..y_0 + nCbS - 1$:

- If **pred_mode_flag** is equal to 0, **CuPredMode**[x][y] is set equal to **MODE_INTER**.
- Otherwise (**pred_mode_flag** is equal to 1), **CuPredMode**[x][y] is set equal to **MODE_INTRA**.

When **pred_mode_flag** is not present, the variable **CuPredMode**[x][y] is derived as follows for $x = x_0..x_0 + nCbS - 1$ and $y = y_0..y_0 + nCbS - 1$:

- If **slice_type** is equal to I, **CuPredMode**[x][y] is inferred to be equal to **MODE_INTRA**.
- Otherwise (**slice_type** is equal to P or B), when **cu_skip_flag**[x_0][y_0] is equal to 1, **CuPredMode**[x][y] is inferred to be equal to **MODE_SKIP**.

palette_mode_flag[x_0][y_0] equal to 1 specifies that the current coding unit is coded using the palette mode. **palette_mode_flag**[x_0][y_0] equal to 0 specifies that the current coding unit is not coded using the palette mode. The array indices x_0 and y_0 specify the location (x_0 , y_0) of the top-left luma sample of the considered coding block relative to the top-left luma sample of the picture.

When **palette_mode_flag**[x_0][y_0] is not present, it is inferred to be equal to 0.

part_mode specifies the partitioning mode of the current coding unit. The semantics of **part_mode** depend on **CuPredMode**[x_0][y_0]. The variables **PartMode** and **IntraSplitFlag** are derived from the value of **part_mode** as defined in Table 7-10.

The value of **part_mode** is restricted as follows:

- If **CuPredMode**[x_0][y_0] is equal to **MODE_INTRA**, **part_mode** shall be equal to 0 or 1.
- Otherwise (**CuPredMode**[x_0][y_0] is equal to **MODE_INTER**), the following apply:
 - If **log2CbSize** is greater than **MinCbLog2SizeY** and **amp_enabled_flag** is equal to 1, **part_mode** shall be in the range of 0 to 2, inclusive, or in the range of 4 to 7, inclusive.
 - Otherwise, if **log2CbSize** is greater than **MinCbLog2SizeY** and **amp_enabled_flag** is equal to 0, or **log2CbSize** is equal to 3, **part_mode** shall be in the range of 0 to 2, inclusive.
 - Otherwise (**log2CbSize** is greater than 3 and equal to **MinCbLog2SizeY**), the value of **part_mode** shall be in the range of 0 to 3, inclusive.

When **part_mode** is not present, the variables **PartMode** and **IntraSplitFlag** are derived as follows:

- **PartMode** is set equal to **PART_2Nx2N**.
- **IntraSplitFlag** is set equal to 0.

pcm_flag[x0][y0] equal to 1 specifies that the pcm_sample() syntax structure is present and the transform_tree() syntax structure is not present in the coding unit including the luma coding block at the location (x0, y0). pcm_flag[x0][y0] equal to 0 specifies that pcm_sample() syntax structure is not present. When pcm_flag[x0][y0] is not present, it is inferred to be equal to 0.

The value of pcm_flag[x0 + i][y0 + j] with $i = 1..nC_bS - 1$, $j = 1..nC_bS - 1$ is inferred to be equal to pcm_flag[x0][y0].

pcm_alignment_zero_bit is a bit equal to 0.

Table 7-10 — Name association to prediction mode and partitioning type

CuPredMode[x0][y0]	part_mode	IntraSplitFlag	PartMode
MODE_INTRA	0	0	PART_2Nx2N
	1	1	PART_NxN
MODE_INTER	0	0	PART_2Nx2N
	1	0	PART_2NxN
	2	0	PART_Nx2N
	3	0	PART_NxN
	4	0	PART_2NxN _U
	5	0	PART_2NxN _D
	6	0	PART_nLx2N
	7	0	PART_nRx2N

The syntax elements **prev_intra_luma_pred_flag**[x0 + i][y0 + j], **mpm_idx**[x0 + i][y0 + j] and **rem_intra_luma_pred_mode**[x0 + i][y0 + j] specify the intra prediction mode for luma samples. The array indices x0 + i, y0 + j specify the location (x0 + i, y0 + j) of the top-left luma sample of the considered prediction block relative to the top-left luma sample of the picture. When prev_intra_luma_pred_flag[x0 + i][y0 + j] is equal to 1, the intra prediction mode is inferred from a neighbouring intra-predicted prediction unit according to 8.4.2.

intra_chroma_pred_mode[x0][y0] specifies the intra prediction mode for chroma samples. The array indices x0, y0 specify the location (x0, y0) of the top-left luma sample of the considered prediction block relative to the top-left luma sample of the picture.

rqt_root_cbf equal to 1 specifies that the transform_tree() syntax structure is present for the current coding unit. rqt_root_cbf equal to 0 specifies that the transform_tree() syntax structure is not present for the current coding unit.

When rqt_root_cbf is not present, its value is inferred to be equal to 1.

7.4.9.6 Prediction unit semantics

mvp_l0_flag[x0][y0] specifies the motion vector predictor index of list 0 where x0, y0 specify the location (x0, y0) of the top-left luma sample of the considered prediction block relative to the top-left luma sample of the picture.

When mvp_l0_flag[x0][y0] is not present, it is inferred to be equal to 0.

mvp_l1_flag[x0][y0] has the same semantics as mvp_l0_flag, with l0 and list 0 replaced by l1 and list 1, respectively.

merge_flag[x0][y0] specifies whether the inter prediction parameters for the current prediction unit are inferred from a neighbouring inter-predicted partition. The array indices x0, y0 specify the location (x0, y0) of the top-left luma sample of the considered prediction block relative to the top-left luma sample of the picture.

When merge_flag[x0][y0] is not present, it is inferred as follows:

- If $\text{CuPredMode}[x0][y0]$ is equal to MODE_SKIP , $\text{merge_flag}[x0][y0]$ is inferred to be equal to 1.
- Otherwise, $\text{merge_flag}[x0][y0]$ is inferred to be equal to 0.

merge_idx $[x0][y0]$ specifies the merging candidate index of the merging candidate list where $x0, y0$ specify the location $(x0, y0)$ of the top-left luma sample of the considered prediction block relative to the top-left luma sample of the picture.

When $\text{merge_idx}[x0][y0]$ is not present, it is inferred to be equal to 0.

inter_pred_idc $[x0][y0]$ specifies whether list0, list1, or bi-prediction is used for the current prediction unit according to Table 7-11. The array indices $x0, y0$ specify the location $(x0, y0)$ of the top-left luma sample of the considered prediction block relative to the top-left luma sample of the picture.

Table 7-11 — Name association to inter prediction mode

inter_pred_idc	Name of inter_pred_idc	
	$(nPbW + nPbH) \neq 12$	$(nPbW + nPbH) = 12$
0	PRED_L0	PRED_L0
1	PRED_L1	PRED_L1
2	PRED_BI	na

When $\text{inter_pred_idc}[x0][y0]$ is not present, it is inferred to be equal to PRED_L0 .

ref_idx_l0 $[x0][y0]$ specifies the list 0 reference picture index for the current prediction unit. The array indices $x0, y0$ specify the location $(x0, y0)$ of the top-left luma sample of the considered prediction block relative to the top-left luma sample of the picture.

When $\text{ref_idx_l0}[x0][y0]$ is not present, it is inferred to be equal to 0.

ref_idx_l1 $[x0][y0]$ has the same semantics as ref_idx_l0 , with l0 and list 0 replaced by l1 and list 1, respectively.

7.4.9.7 PCM sample semantics

pcm_sample_luma $[i]$ represents a coded luma sample value in the raster scan within the coding unit. The number of bits used to represent each of these samples is PcmBitDepth_Y .

pcm_sample_chroma $[i]$ represents a coded chroma sample value in the raster scan within the coding unit. The first half of the values represent coded Cb samples and the remaining half of the values represent coded Cr samples. The number of bits used to represent each of these samples is PcmBitDepth_C .

7.4.9.8 Transform tree semantics

split_transform_flag $[x0][y0][\text{trafoDepth}]$ specifies whether a block is split into four blocks with half horizontal and half vertical size for the purpose of transform coding. The array indices $x0, y0$ specify the location $(x0, y0)$ of the top-left luma sample of the considered block relative to the top-left luma sample of the picture. The array index trafoDepth specifies the current subdivision level of a coding block into blocks for the purpose of transform coding. trafoDepth is equal to 0 for blocks that correspond to coding blocks.

The variable interSplitFlag is derived as follows:

- If $\text{max_transform_hierarchy_depth_inter}$ is equal to 0 and $\text{CuPredMode}[x0][y0]$ is equal to MODE_INTER and PartMode is not equal to PART_2Nx2N and trafoDepth is equal to 0, interSplitFlag is set equal to 1.
- Otherwise, interSplitFlag is set equal to 0.

ISO/IEC 23008-2:2017(E)

When `split_transform_flag[x0][y0][trafoDepth]` is not present, it is inferred as follows:

- If one or more of the following conditions are true, the value of `split_transform_flag[x0][y0][trafoDepth]` is inferred to be equal to 1:
 - `log2TrafoSize` is greater than `MaxTbLog2SizeY`;
 - `IntraSplitFlag` is equal to 1 and `trafoDepth` is equal to 0;
 - `interSplitFlag` is equal to 1.
- Otherwise, the value of `split_transform_flag[x0][y0][trafoDepth]` is inferred to be equal to 0.

`cbf_luma[x0][y0][trafoDepth]` equal to 1 specifies that the luma transform block contains one or more transform coefficient levels not equal to 0. The array indices `x0`, `y0` specify the location (`x0`, `y0`) of the top-left luma sample of the considered transform block relative to the top-left luma sample of the picture. The array index `trafoDepth` specifies the current subdivision level of a coding block into blocks for the purpose of transform coding. `trafoDepth` is equal to 0 for blocks that correspond to coding blocks.

When `cbf_luma[x0][y0][trafoDepth]` is not present, it is inferred to be equal to 1.

`cbf_cb[x0][y0][trafoDepth]` equal to 1 specifies that the Cb transform block contains one or more transform coefficient levels not equal to 0. The array indices `x0`, `y0` specify the top-left location (`x0`, `y0`) of the considered transform block. The array index `trafoDepth` specifies the current subdivision level of a coding block into blocks for the purpose of transform coding. `trafoDepth` is equal to 0 for blocks that correspond to coding blocks.

When `cbf_cb[x0][y0][trafoDepth]` is not present, it is inferred to be equal to 0.

`cbf_cr[x0][y0][trafoDepth]` equal to 1 specifies that the Cr transform block contains one or more transform coefficient levels not equal to 0. The array indices `x0`, `y0` specify the top-left location (`x0`, `y0`) of the considered transform block. The array index `trafoDepth` specifies the current subdivision level of a coding block into blocks for the purpose of transform coding. `trafoDepth` is equal to 0 for blocks that correspond to coding blocks.

When `cbf_cr[x0][y0][trafoDepth]` is not present, it is inferred to be equal to 0.

7.4.9.9 Motion vector difference semantics

`abs_mvd_greater0_flag[compIdx]` specifies whether the absolute value of a motion vector component difference is greater than 0.

`abs_mvd_greater1_flag[compIdx]` specifies whether the absolute value of a motion vector component difference is greater than 1.

When `abs_mvd_greater1_flag[compIdx]` is not present, it is inferred to be equal to 0.

`abs_mvd_minus2[compIdx]` plus 2 specifies the absolute value of a motion vector component difference.

When `abs_mvd_minus2[compIdx]` is not present, it is inferred to be equal to -1.

`mvd_sign_flag[compIdx]` specifies the sign of a motion vector component difference as follows:

- If `mvd_sign_flag[compIdx]` is equal to 0, the corresponding motion vector component difference has a positive value.
- Otherwise (`mvd_sign_flag[compIdx]` is equal to 1), the corresponding motion vector component difference has a negative value.

When `mvd_sign_flag[compIdx]` is not present, it is inferred to be equal to 0.

The motion vector difference $lMvd[compIdx]$ for $compIdx = 0..1$ is derived as follows:

$$lMvd[compIdx] = abs_mvd_greater0_flag[compIdx] * (abs_mvd_minus2[compIdx] + 2) * (1 - 2 * mvd_sign_flag[compIdx]) \quad (7-73)$$

The variable $MvdLX[x0][y0][compIdx]$, with X being 0 or 1, specifies the difference between a list X vector component to be used and its prediction. The value of $MvdLX[x0][y0][compIdx]$ shall be in the range of -2^{15} to $2^{15} - 1$, inclusive. The array indices $x0, y0$ specify the location $(x0, y0)$ of the top-left luma sample of the considered prediction block relative to the top-left luma sample of the picture. The horizontal motion vector component difference is assigned $compIdx = 0$ and the vertical motion vector component is assigned $compIdx = 1$.

- If $refList$ is equal to 0, $MvdL0[x0][y0][compIdx]$ is set equal to $lMvd[compIdx]$ for $compIdx = 0..1$.
- Otherwise ($refList$ is equal to 1), $MvdL1[x0][y0][compIdx]$ is set equal to $lMvd[compIdx]$ for $compIdx = 0..1$.

7.4.9.10 Transform unit semantics

The transform coefficient levels are represented by the arrays $TransCoeffLevel[x0][y0][cIdx][xC][yC]$, which are either specified in 7.3.8.11 or inferred as follows. The array indices $x0, y0$ specify the location $(x0, y0)$ of the top-left luma sample of the considered transform block relative to the top-left luma sample of the picture. The array index $cIdx$ specifies an indicator for the colour component; it is equal to 0 for Y, 1 for Cb, and 2 for Cr. The array indices xC and yC specify the transform coefficient location (xC, yC) within the current transform block. When the value of $TransCoeffLevel[x0][y0][cIdx][xC][yC]$ is not specified in 7.3.8.11, it is inferred to be equal to 0.

tu_residual_act_flag $[x0][y0]$ equal to 1 specifies that adaptive colour transform is applied to the residual samples of the current transform unit. **tu_residual_act_flag** $[x0][y0]$ equal to 0 specifies that adaptive colour transform is not applied to the residual samples of the current transform unit. When **tu_residual_act_flag** $[x0][y0]$ is not present, it is inferred to be equal to 0.

When **cu_transquant_bypass_flag** is equal to 1 and **bit_depth_luma_minus8** is not equal to **bit_depth_chroma_minus8**, the value of **tu_residual_act_flag** $[x0][y0]$, when present, shall be equal to 0.

7.4.9.11 Residual coding semantics

For intra prediction, different scanning orders are used. The variable **scanIdx** specifies which scan order is used where **scanIdx** equal to 0 specifies an up-right diagonal scan order, **scanIdx** equal to 1 specifies a horizontal scan order, and **scanIdx** equal to 2 specifies a vertical scan order. The value of **scanIdx** is derived as follows:

- If **CuPredMode** $[x0][y0]$ is equal to **MODE_INTRA** and one or more of the following conditions are true:
 - **log2TrafoSize** is equal to 2.
 - **log2TrafoSize** is equal to 3 and **cIdx** is equal to 0.
 - **log2TrafoSize** is equal to 3 and **ChromaArrayType** is equal to 3.

predModeIntra is derived as follows:

- If **cIdx** is equal to 0, **predModeIntra** is set equal to **IntraPredModeY** $[x0][y0]$.
- Otherwise, **predModeIntra** is set equal to **IntraPredModeC**.

scanIdx is derived as follows:

ISO/IEC 23008-2:2017(E)

- If `predModeIntra` is in the range of 6 to 14, inclusive, `scanIdx` is set equal to 2.
 - Otherwise if `predModeIntra` is in the range of 22 to 30, inclusive, `scanIdx` is set equal to 1.
 - Otherwise, `scanIdx` is set equal to 0.
- Otherwise, `scanIdx` is set equal to 0.

transform_skip_flag[`x0`][`y0`][`cIdx`] specifies whether a transform is applied to the associated transform block or not. The array indices `x0`, `y0` specify the location (`x0`, `y0`) of the top-left luma sample of the considered transform block relative to the top-left luma sample of the picture. The array index `cIdx` specifies an indicator for the colour component; it is equal to 0 for luma, equal to 1 for Cb, and equal to 2 for Cr. `transform_skip_flag`[`x0`][`y0`][`cIdx`] equal to 1 specifies that no transform is applied to the current transform block. `transform_skip_flag`[`x0`][`y0`][`cIdx`] equal to 0 specifies that the decision whether transform is applied to the current transform block or not depends on other syntax elements. When `transform_skip_flag`[`x0`][`y0`][`cIdx`] is not present, it is inferred to be equal to 0.

explicit_rdpem_flag[`x0`][`y0`][`cIdx`] specifies whether the residual modification process for blocks using a transform bypass is applied to the associated transform block or not. The array indices `x0`, `y0` specify the location (`x0`, `y0`) of the top-left luma sample of the considered transform block relative to the top-left luma sample of the picture. The array index `cIdx` specifies an indicator for the colour component; it is equal to 0 for luma, equal to 1 for Cb, and equal to 2 for Cr. `explicit_rdpem_flag`[`x0`][`y0`][`cIdx`] equal to 1 specifies that the residual modification process is applied to the current transform block. `explicit_rdpem_flag`[`x0`][`y0`][`cIdx`] equal to 0 specifies that no residual modification process is applied to the current transform block. When `explicit_rdpem_flag`[`x0`][`y0`][`cIdx`] is not present, it is inferred to be equal to 0.

explicit_rdpem_dir_flag[`x0`][`y0`][`cIdx`] specifies the direction to be used by the residual modification process for the associated transform block. The array indices `x0`, `y0` specify the location (`x0`, `y0`) of the top-left luma sample of the considered transform block relative to the top-left luma sample of the picture. The array index `cIdx` specifies an indicator for the colour component; it is equal to 0 for luma, equal to 1 for Cb, and equal to 2 for Cr.

last_sig_coeff_x_prefix specifies the prefix of the column position of the last significant coefficient in scanning order within a transform block. The values of `last_sig_coeff_x_prefix` shall be in the range of 0 to ($\log_2 \text{TrafoSize} \ll 1$) - 1, inclusive.

last_sig_coeff_y_prefix specifies the prefix of the row position of the last significant coefficient in scanning order within a transform block. The values of `last_sig_coeff_y_prefix` shall be in the range of 0 to ($\log_2 \text{TrafoSize} \ll 1$) - 1, inclusive.

last_sig_coeff_x_suffix specifies the suffix of the column position of the last significant coefficient in scanning order within a transform block. The values of `last_sig_coeff_x_suffix` shall be in the range of 0 to ($1 \ll ((\text{last_sig_coeff_x_prefix} \gg 1) - 1)$) - 1, inclusive.

The column position of the last significant coefficient in scanning order within a transform block `LastSignificantCoeffX` is derived as follows:

- If `last_sig_coeff_x_suffix` is not present, the following applies:

$$\text{LastSignificantCoeffX} = \text{last_sig_coeff_x_prefix} \quad (7-74)$$

- Otherwise (`last_sig_coeff_x_suffix` is present), the following applies:

$$\text{LastSignificantCoeffX} = (1 \ll ((\text{last_sig_coeff_x_prefix} \gg 1) - 1)) * (2 + (\text{last_sig_coeff_x_prefix} \& 1)) + \text{last_sig_coeff_x_suffix} \quad (7-75)$$

last_sig_coeff_y_suffix specifies the suffix of the row position of the last significant coefficient in scanning order within a transform block. The values of **last_sig_coeff_y_suffix** shall be in the range of 0 to $(1 \ll ((\text{last_sig_coeff_y_prefix} \gg 1) - 1)) - 1$, inclusive.

The row position of the last significant coefficient in scanning order within a transform block **LastSignificantCoeffY** is derived as follows:

- If **last_sig_coeff_y_suffix** is not present, the following applies:

$$\text{LastSignificantCoeffY} = \text{last_sig_coeff_y_prefix} \quad (7-76)$$

- Otherwise (**last_sig_coeff_y_suffix** is present), the following applies:

$$\text{LastSignificantCoeffY} = (1 \ll ((\text{last_sig_coeff_y_prefix} \gg 1) - 1)) * (2 + (\text{last_sig_coeff_y_prefix} \& 1)) + \text{last_sig_coeff_y_suffix} \quad (7-77)$$

When **scanIdx** is equal to 2, the coordinates are swapped as follows:

$$(\text{LastSignificantCoeffX}, \text{LastSignificantCoeffY}) = \text{Swap}(\text{LastSignificantCoeffX}, \text{LastSignificantCoeffY}) \quad (7-78)$$

coded_sub_block_flag[xS][yS] specifies the following for the sub-block at location (xS, yS) within the current transform block, where a sub-block is a (4x4) array of 16 transform coefficient levels:

- If **coded_sub_block_flag[xS][yS]** is equal to 0, the 16 transform coefficient levels of the sub-block at location (xS, yS) are inferred to be equal to 0.
- Otherwise (**coded_sub_block_flag[xS][yS]** is equal to 1), the following apply:
 - If (xS, yS) is equal to (0, 0) and (LastSignificantCoeffX, LastSignificantCoeffY) is not equal to (0, 0), at least one of the 16 **sig_coeff_flag** syntax elements is present for the sub-block at location (xS, yS).
 - Otherwise, at least one of the 16 transform coefficient levels of the sub-block at location (xS, yS) has a non-zero value.

When **coded_sub_block_flag[xS][yS]** is not present, it is inferred as follows:

- If one or more of the following conditions are true, **coded_sub_block_flag[xS][yS]** is inferred to be equal to 1:
 - (xS, yS) is equal to (0, 0).
 - (xS, yS) is equal to (LastSignificantCoeffX >> 2, LastSignificantCoeffY >> 2).
- Otherwise, **coded_sub_block_flag[xS][yS]** is inferred to be equal to 0.

sig_coeff_flag[xC][yC] specifies for the transform coefficient location (xC, yC) within the current transform block whether the corresponding transform coefficient level at the location (xC, yC) is non-zero as follows:

- If **sig_coeff_flag[xC][yC]** is equal to 0, the transform coefficient level at the location (xC, yC) is set equal to 0.
- Otherwise (**sig_coeff_flag[xC][yC]** is equal to 1), the transform coefficient level at the location (xC, yC) has a non-zero value.

When **sig_coeff_flag[xC][yC]** is not present, it is inferred as follows:

ISO/IEC 23008-2:2017(E)

- If (x_C, y_C) is the last significant location (LastSignificantCoeffX, LastSignificantCoeffY) in scan order or all of the following conditions are true, sig_coeff_flag[x_C][y_C] is inferred to be equal to 1:
 - ($x_C \& 3, y_C \& 3$) is equal to (0, 0).
 - inferSbDcSigCoeffFlag is equal to 1.
 - coded_sub_block_flag[x_S][y_S] is equal to 1.
- Otherwise, sig_coeff_flag[x_C][y_C] is inferred to be equal to 0.

coeff_abs_level_greater1_flag[n] specifies for the scanning position n whether there are absolute values of transform coefficient levels greater than 1.

When coeff_abs_level_greater1_flag[n] is not present, it is inferred to be equal to 0.

coeff_abs_level_greater2_flag[n] specifies for the scanning position n whether there are absolute values of transform coefficient levels greater than 2.

When coeff_abs_level_greater2_flag[n] is not present, it is inferred to be equal to 0.

coeff_sign_flag[n] specifies the sign of a transform coefficient level for the scanning position n as follows:

- If coeff_sign_flag[n] is equal to 0, the corresponding transform coefficient level has a positive value.
- Otherwise (coeff_sign_flag[n] is equal to 1), the corresponding transform coefficient level has a negative value.

When coeff_sign_flag[n] is not present, it is inferred to be equal to 0.

coeff_abs_level_remaining[n] is the remaining absolute value of a transform coefficient level that is coded with Golomb-Rice code at the scanning position n . When coeff_abs_level_remaining[n] is not present, it is inferred to be equal to 0.

It is a requirement of bitstream conformance that the value of coeff_abs_level_remaining[n] shall be constrained such that the corresponding value of TransCoeffLevel[x_0][y_0][$cIdx$][x_C][y_C] is in the range of CoeffMin _{γ} to CoeffMax _{γ} , inclusive, for $cIdx$ equal to 0, and in the range of CoeffMin _{c} to CoeffMax _{c} , inclusive, for $cIdx$ not equal to 0.

7.4.9.12 Cross-component prediction semantics

log2_res_scale_abs_plus1[c] minus 1 specifies the base 2 logarithm of the magnitude of the scaling factor ResScaleVal used in cross-component residual prediction. When not present, log2_res_scale_abs_plus1 is inferred to be equal to 0.

res_scale_sign_flag[c] specifies the sign of the scaling factor used in cross-component residual prediction as follows:

- If res_scale_sign_flag[c] is equal to 0, the corresponding ResScaleVal has a positive value.
- Otherwise (res_scale_sign_flag[c] is equal to 1), the corresponding ResScaleVal has a negative value.

The variable ResScaleVal[$cIdx$][x_0][y_0] specifies the scaling factor used in cross-component residual prediction. The array indices x_0, y_0 specify the location (x_0, y_0) of the top-left luma sample of the considered transform block relative to the top-left luma sample of the picture. The array index $cIdx$ specifies an indicator for the colour component; it is equal to 1 for Cb, and equal to 2 for Cr.

The variable ResScaleVal[$cIdx$][x_0][y_0] is derived as follows:

— If $\log_2\text{res_scale_abs_plus1}[cIdx - 1]$ is equal to 0, the following applies:

$$\text{ResScaleVal}[cIdx][x0][y0] = 0 \quad (7-79)$$

— Otherwise ($\log_2\text{res_scale_abs_plus1}[cIdx - 1]$ is not equal to 0), the following applies:

$$\text{ResScaleVal}[cIdx][x0][y0] = (1 \ll (\log_2\text{res_scale_abs_plus1}[cIdx - 1] - 1)) * (1 - 2 * \text{res_scale_sign_flag}[cIdx - 1]) \quad (7-80)$$

7.4.9.13 Palette semantics

In the following semantics, the array indices $x0$, $y0$ specify the location $(x0, y0)$ of the top-left luma sample of the considered coding block relative to the top-left luma sample of the picture.

The predictor palette consists of palette entries from previous coding units that are used to predict the entries in the current palette.

The variable `PredictorPaletteSize` specifies the size of the predictor palette. `PredictorPaletteSize` is derived as specified in 8.4.4.2.7.

The variable `PalettePredictorEntryReuseFlags[i]` equal to 1 specifies that the i -th entry in the predictor palette is reused in the current palette. `PalettePredictorEntryReuseFlags[i]` equal to 0 specifies that the i -th entry in the predictor palette is not an entry in the current palette. All elements of the array `PalettePredictorEntryReuseFlags[i]` are initialized to 0.

palette_predictor_run is used to determine the number of zeros that precede a non-zero entry in the array `PalettePredictorEntryReuseFlags`.

It is a requirement of bitstream conformance that the value of `palette_predictor_run` shall be in the range of 0 to $(\text{PredictorPaletteSize} - \text{predictorEntryIdx})$, inclusive, where `predictorEntryIdx` corresponds to the current position in the array `PalettePredictorEntryReuseFlags`. The variable `NumPredictedPaletteEntries` specifies the number of entries in the current palette that are reused from the predictor palette. The value of `NumPredictedPaletteEntries` shall be in the range of 0 to `palette_max_size`, inclusive.

num_signalled_palette_entries specifies the number of entries in the current palette that are explicitly signalled.

When `num_signalled_palette_entries` is not present, it is inferred to be equal to 0.

The variable `CurrentPaletteSize` specifies the size of the current palette and is derived as follows:

$$\text{CurrentPaletteSize} = \text{NumPredictedPaletteEntries} + \text{num_signalled_palette_entries} \quad (7-81)$$

The value of `CurrentPaletteSize` shall be in the range of 0 to `palette_max_size`, inclusive.

new_palette_entries $[cIdx][i]$ specifies the value for the i -th signalled palette entry for the colour component $cIdx$.

The variable `PredictorPaletteEntries[cIdx][i]` specifies the i -th element in the predictor palette for the colour component $cIdx$.

The variable `CurrentPaletteEntries[cIdx][i]` specifies the i -th element in the current palette for the colour component $cIdx$ and is derived as follows:

```

numComps = ( ChromaArrayType == 0 ) ? 1 : 3
numPredictedPaletteEntries = 0
for( i = 0; i < PredictorPaletteSize; i++ )
    if( PalettePredictorEntryReuseFlags[ i ] ) {
        for( cIdx = 0; cIdx < numComps; cIdx++ )
            CurrentPaletteEntries[ cIdx ][ numPredictedPaletteEntries ] =
                PredictorPaletteEntries[ cIdx ][ i ]
        numPredictedPaletteEntries++
    }

```

```

    }
    for( cIdx = 0; cIdx < numComps; cIdx++ )
        for( i = 0; i < num_signalled_palette_entries; i++ )
            CurrentPaletteEntries[ cIdx ][ numPredictedPaletteEntries + i ] = new_palette_entries[ cIdx ][ i ]
    }
    (7-82)

```

palette_escape_val_present_flag equal to 1 specifies that the current coding unit contains at least one escape coded sample. **palette_escape_val_present_flag** equal to 0 specifies that there are no escape coded samples in the current coding unit. When not present, the value of **palette_escape_val_present_flag** is inferred to be equal to 1.

The variable **MaxPaletteIndex** specifies the maximum possible value for a palette index for the current coding unit. The value of **MaxPaletteIndex** is set equal to **CurrentPaletteSize - 1 + palette_escape_val_present_flag**.

num_palette_indices_minus1 plus 1 is the number of palette indices explicitly signalled or inferred for the current block.

When **num_palette_indices_minus1** is not present, it is inferred to be equal to 0.

palette_index_idc is an indication of an index to the array represented by **CurrentPaletteEntries**. The value of **palette_index_idc** shall be in the range of 0 to **MaxPaletteIndex**, inclusive, for the first index in the block and in the range of 0 to (**MaxPaletteIndex - 1**), inclusive, for the remaining indices in the block.

When **palette_index_idc** is not present, it is inferred to be equal to 0.

The variable **PaletteIndexIdc[i]** stores the *i*-th **palette_index_idc** explicitly signalled or inferred. All elements of the array **PaletteIndexIdc[i]** are initialized to 0.

copy_above_indices_for_final_run_flag equal to 1 specifies that the palette indices of the last positions in the coding unit are copied from the palette indices in the row above. **copy_above_indices_for_final_run_flag** equal to 0 specifies that the palette indices of the last positions in the coding unit are copied from **PaletteIndexIdc[num_palette_indices_minus1]**.

When **copy_above_indices_for_final_run_flag** is not present, it is inferred to be equal to 0.

palette_transpose_flag equal to 1 specifies that the transpose process is applied to the reconstructed sample array at the output of palette mode decoding as specified in 8.4.4.2.7 in the current coding unit. **palette_transpose_flag** equal to 0 specifies that the transpose process is not applied to the reconstructed sample array at the output of palette mode decoding 8.4.4.2.7 in the current coding unit.

copy_above_palette_indices_flag equal to 1 specifies that the palette index is equal to the palette index at the same location in the row above. **copy_above_palette_indices_flag** equal to 0 specifies that an indication of the palette index of the sample is coded in the bitstream or inferred.

The variable **CopyAboveIndicesFlag[xC][yC]** equal to 1 specifies that the palette index is copied from the palette index in the row above. **CopyAboveIndicesFlag[xC][yC]** equal to 0 specifies that the palette index is explicitly coded in the bitstream or inferred. The array indices *xC*, *yC* specify the location (*xC*, *yC*) of the sample relative to the top-left luma sample of the picture.

The variable **PaletteIndexMap[xC][yC]** specifies a palette index, which is an index to the array represented by **CurrentPaletteEntries**. The array indices *xC*, *yC* specify the location (*xC*, *yC*) of the sample relative to the top-left luma sample of the picture. The value of **PaletteIndexMap[xC][yC]** shall be in the range of 0 to **MaxPaletteIndex**, inclusive.

The variable **adjustedRefPaletteIndex** is derived as follows:

```

adjustedRefPaletteIndex = MaxPaletteIndex + 1
log2BlkSize = Log2( nCbs ) - 2
if( PaletteScanPos > 0 ) {
    xcPrev = x0 + ScanOrder[ log2BlkSize ][ 3 ][ PaletteScanPos - 1 ][ 0 ]
    ycPrev = y0 + ScanOrder[ log2BlkSize ][ 3 ][ PaletteScanPos - 1 ][ 1 ]
    if( CopyAboveIndicesFlag[ xcPrev ][ ycPrev ] = 0 )

```

adjustedRefPaletteIndex = PaletteIndexMap[xcPrev][ycPrev] (7-83)

else

adjustedRefPaletteIndex = PaletteIndexMap[xC][yC - 1]

When CopyAboveIndicesFlag[xC][yC] is equal to 0, the variable CurrPaletteIndex is derived as follows:

if(CurrPaletteIndex >= adjustedRefPaletteIndex)
CurrPaletteIndex++ (7-84)

The variable PaletteRun specifies the number of consecutive locations minus 1 with the same palette index as the position in the above row when CopyAboveIndicesFlag[xC][yC] is equal to 1 or specifies the number of consecutive locations minus 1 with the same palette index when CopyAboveIndicesFlag[xC][yC] is equal to 0.

The variable PaletteMaxRun represents the maximum possible value for PaletteRun. It is a requirement of bitstream conformance that the value of PaletteMaxRun shall be greater than or equal to 0.

palette_run_prefix specifies the prefix part in the binarization of PaletteRun.

palette_run_suffix specifies the suffix part in the binarization of PaletteRun. When palette_run_suffix is not present, the value of palette_run_suffix is inferred to be equal to 0.

The value of PaletteRun is derived as follows:

— If palette_run_prefix is less than 2, the following applies:

PaletteRun = palette_run_prefix (7-85)

— Otherwise (palette_run_prefix is greater than or equal to 2), the following applies:

PrefixOffset = 1 << (palette_run_prefix - 1)

PaletteRun = PrefixOffset + palette_run_suffix (7-86)

palette_escape_val specifies the quantized escape coded sample value for a component.

The variable PaletteEscapeVal[cIdx][xC][yC] specifies the escape value of a sample for which PaletteIndexMap[xC][yC] is equal to MaxPaletteIndex and palette_escape_val_present_flag is equal to 1. The array index cIdx specifies the colour component. The array indices xC, yC specify the location (xC, yC) of the sample relative to the top-left luma sample of the picture.

It is a requirement of bitstream conformance that PaletteEscapeVal[cIdx][xC][yC] shall be in the range of 0 to $(1 \ll (\text{BitDepth}_Y + 1)) - 1$, inclusive, for cIdx equal to 0, and in the range of 0 to $(1 \ll (\text{BitDepth}_C + 1)) - 1$, inclusive, for cIdx not equal to 0.

7.4.9.14 Delta QP semantics

cu_qp_delta_abs specifies the absolute value of the difference CuQpDeltaVal between the luma quantization parameter of the current coding unit and its prediction.

cu_qp_delta_sign_flag specifies the sign of CuQpDeltaVal as follows:

— If cu_qp_delta_sign_flag is equal to 0, the corresponding CuQpDeltaVal has a positive value.

— Otherwise (cu_qp_delta_sign_flag is equal to 1), the corresponding CuQpDeltaVal has a negative value.

When cu_qp_delta_sign_flag is not present, it is inferred to be equal to 0.

When cu_qp_delta_abs is present, the variables IsCuQpDeltaCoded and CuQpDeltaVal are derived as follows:

ISO/IEC 23008-2:2017(E)

$$\text{IsCuQpDeltaCoded} = 1 \quad (7-87)$$

$$\text{CuQpDeltaVal} = \text{cu_qp_delta_abs} * (1 - 2 * \text{cu_qp_delta_sign_flag}) \quad (7-88)$$

The value of CuQpDeltaVal shall be in the range of $-(26 + \text{QpBdOffsetY} / 2)$ to $+(25 + \text{QpBdOffsetY} / 2)$, inclusive.

7.4.9.15 Chroma QP offset semantics

cu_chroma_qp_offset_flag, when present and equal to 1, specifies that an entry in the `cb_qp_offset_list[]` is used to determine the value of CuQpOffsetCb and a corresponding entry in the `cr_qp_offset_list[]` is used to determine the value of CuQpOffsetCr. `cu_chroma_qp_offset_flag` equal to 0 specifies that these lists are not used to determine the values of CuQpOffsetCb and CuQpOffsetCr.

cu_chroma_qp_offset_idx, when present, specifies the index into the `cb_qp_offset_list[]` and `cr_qp_offset_list[]` that is used to determine the value of CuQpOffsetCb and CuQpOffsetCr. When present, the value of `cu_chroma_qp_offset_idx` shall be in the range of 0 to `chroma_qp_offset_list_len_minus1`, inclusive. When not present, the value of `cu_chroma_qp_offset_idx` is inferred to be equal to 0.

When `cu_chroma_qp_offset_flag` is present, the following apply:

- The variable `IsCuChromaQpOffsetCoded` is set equal to 1.
- The variables `CuQpOffsetCb` and `CuQpOffsetCr` are derived as follows:
 - If `cu_chroma_qp_offset_flag` is equal to 1, the following apply:

$$\text{CuQpOffsetCb} = \text{cb_qp_offset_list}[\text{cu_chroma_qp_offset_idx}] \quad (7-89)$$

$$\text{CuQpOffsetCr} = \text{cr_qp_offset_list}[\text{cu_chroma_qp_offset_idx}] \quad (7-90)$$

- Otherwise (`cu_chroma_qp_offset_flag` is equal to 0), `CuQpOffsetCb` and `CuQpOffsetCr` are both set equal to 0.

NOTE When `cu_chroma_qp_offset_enabled_flag` is equal to 0, `CuQpOffsetCb` and `CuQpOffsetCr` are not modified after being initialized to 0 for the slice as specified in 7.4.7.1.

8 Decoding process

8.1 General decoding process

8.1.1 General

Input to this process is a bitstream. Output of this process is a list of decoded pictures.

The decoding process is specified such that all decoders that conform to a specified profile, tier, and level will produce numerically identical cropped decoded output pictures when invoking the decoding process associated with that profile for a bitstream conforming to that profile, tier and level. Any decoding process that produces identical cropped decoded output pictures to those produced by the process described herein (with the correct output order or output timing, as specified) conforms to the decoding process requirements of this document.

NOTE For the purpose of best-effort decoding, a decoder that conforms to a particular profile at a given tier and level may additionally decode some bitstreams conforming to a different tier, level or profile without necessarily using a decoding process that produces numerically identical cropped decoded output pictures to those produced by the process specified herein (without claiming conformance to the other profile, tier and level).

At the beginning of decoding a CVSG, after activating the VPS RBSP that is active for the entire CVSG and before decoding any VCL NAL units of the CVSG, 8.1.2 is invoked with the CVSG as input.

8.1.2 CVSG decoding process

Input to this process is a CVSG. Output of this process is a list of decoded pictures.

The layer identifier list `TargetDecLayerIdList`, which specifies the list of `nuh_layer_id` values, in increasing order of `nuh_layer_id` values, of the NAL units to be decoded, is specified as follows:

- If some external means, not specified in this document, is available to set `TargetDecLayerIdList`, `TargetDecLayerIdList` is set by the external means.
- Otherwise, if the decoding process is invoked in a bitstream conformance test as specified in C.1, `TargetDecLayerIdList` is set as specified in C.1.
- Otherwise, `TargetDecLayerIdList` contains only one `nuh_layer_id` value that is equal to 0.

The variable `HighestTid`, which identifies the highest temporal sub-layer to be decoded, is specified as follows:

- If some external means, not specified in this document, is available to set `HighestTid`, `HighestTid` is set by the external means.
- Otherwise, if the decoding process is invoked in a bitstream conformance test as specified in C.1, `HighestTid` is set as specified in C.1.
- Otherwise, `HighestTid` is set equal to `sps_max_sub_layers_minus1`.

The variable `SubPicHrdFlag` is specified as follows:

- If the decoding process is invoked in a bitstream conformance test as specified in C.1, `SubPicHrdFlag` is set as specified in C.1.
- Otherwise, `SubPicHrdFlag` is set equal to `(SubPicHrdPreferredFlag && sub_pic_hrd_params_present_flag)`.

The sub-bitstream extraction process as specified in Clause 10 is applied with the CVSG, `HighestTid`, and `TargetDecLayerIdList` as inputs, and the output is assigned to a bitstream referred to as `BitstreamToDecode`.

8.1.3 is repeatedly invoked for each coded picture with `nuh_layer_id` equal to 0 in `BitstreamToDecode` in decoding order.

8.1.3 Decoding process for a coded picture with `nuh_layer_id` equal to 0

The decoding processes specified in this subclause apply to each coded picture with `nuh_layer_id` equal to 0, referred to as the current picture and denoted by the variable `CurrPic`, in `BitstreamToDecode`.

Depending on the value of `chroma_format_idc`, the number of sample arrays of the current picture is as follows:

- If `chroma_format_idc` is equal to 0, the current picture consists of 1 sample array S_L .
- Otherwise (`chroma_format_idc` is not equal to 0), the current picture consists of 3 sample arrays S_L , S_{Cb} , S_{Cr} .

The decoding process for the current picture takes as inputs the syntax elements and upper-case variables from Clause 7. When interpreting the semantics of each syntax element in each NAL unit, the term “the bitstream” (or part thereof, e.g. a CVS of the bitstream) refers to `BitstreamToDecode` (or part thereof).

When the current picture is a BLA picture that has `nal_unit_type` equal to `BLA_W_LP` or is a CRA picture, the following apply:

ISO/IEC 23008-2:2017(E)

- If some external means not specified in this document is available to set the variable `UseAltCpbParamsFlag` to a value, `UseAltCpbParamsFlag` is set equal to the value provided by the external means.
- Otherwise, the value of `UseAltCpbParamsFlag` is set equal to 0.

When the current picture is an IRAP picture, the following apply:

- If the current picture is an IDR picture, a BLA picture, the first picture in the bitstream in decoding order, or the first picture that follows an end of sequence NAL unit in decoding order, the variable `NoRaslOutputFlag` is set equal to 1.
- Otherwise, if some external means not specified in this document is available to set the variable `HandleCraAsBlaFlag` to a value for the current picture, the variable `HandleCraAsBlaFlag` is set equal to the value provided by the external means and the variable `NoRaslOutputFlag` is set equal to `HandleCraAsBlaFlag`.
- Otherwise, the variable `HandleCraAsBlaFlag` is set equal to 0 and the variable `NoRaslOutputFlag` is set equal to 0.

Depending on the value of `separate_colour_plane_flag`, the decoding process is structured as follows:

- If `separate_colour_plane_flag` is equal to 0, the decoding process is invoked a single time with the current picture being the output.
- Otherwise (`separate_colour_plane_flag` is equal to 1), the decoding process is invoked three times. Inputs to the decoding process are all NAL units of the coded picture with identical value of `colour_plane_id`. The decoding process of NAL units with a particular value of `colour_plane_id` is specified as if only a CVS with monochrome colour format with that particular value of `colour_plane_id` would be present in the bitstream. The output of each of the three decoding processes is assigned to one of the 3 sample arrays of the current picture, with the NAL units with `colour_plane_id` equal to 0, 1, and 2 being assigned to S_L , S_{Cb} , and S_{Cr} , respectively.

NOTE 1 The variable `ChromaArrayType` is derived as equal to 0 when `separate_colour_plane_flag` is equal to 1 and `chroma_format_idc` is equal to 3. In the decoding process, the value of this variable is evaluated resulting in operations identical to that of monochrome pictures (when `chroma_format_idc` is equal to 0).

The decoding process operates as follows for the current picture `CurrPic`:

1. The decoding of NAL units is specified in 8.2.
2. The processes in 8.3 specify the following decoding processes using syntax elements in the slice segment layer and above:
 - Variables and functions relating to picture order count are derived as specified in 8.3.1. This needs to be invoked only for the first slice segment of a picture.
 - The decoding process for RPS in 8.3.2 is invoked, wherein reference pictures may be marked as “unused for reference” or “used for long-term reference”. This needs to be invoked only for the first slice segment of a picture.
 - A picture storage buffer in the DPB is allocated for storage of the decoded sample values of the current picture after the invocation of the in-loop filter process as specified in 8.7. This version of the current decoded picture is referred to as the current decoded picture after the invocation of the in-loop filter process. When `TwoVersionsOfCurrDecPicFlag` is equal to 0 and `pps_curr_pic_ref_enabled_flag` is equal to 1, this picture storage buffer is marked as “used for long-term reference”. When `TwoVersionsOfCurrDecPicFlag` is equal to 1, another picture storage buffer in the DPB is allocated for storage of the decoded sample values of the current

picture immediately before the invocation of the in-loop filter process as specified in 8.7, and is marked as “used for long-term reference”. This version of the current decoded picture is referred to as the current decoded picture before the invocation of the in-loop filter process. This needs to be invoked only for the first slice segment of a picture.

NOTE 2 When `TwoVersionsOfCurrDecPicFlag` is equal to 0, there is only one version of the current decoded picture. In this case, if `pps_curr_pic_ref_enabled_flag` is equal to 1, the current decoded picture is marked as “used for long-term reference” during the decoding of the current picture and will be marked as “used for short-term reference” at the end of the decoding of the current picture, otherwise it is not marked at all during the decoding of the current picture and will be marked as “used for short-term reference” at the end of the decoding of the current picture. When `TwoVersionsOfCurrDecPicFlag` is equal to 1, there are two versions of the current decoded picture, one of which is marked as “used for long-term reference” during the decoding of the current picture and will be marked as “unused for reference” at the end of the decoding of the current picture, and the other version is not marked at all during the decoding of the current picture and will be marked as “used for short-term reference” at the end of the decoding of the current picture.

- When the current picture is a BLA picture or is a CRA picture with `NoRaslOutputFlag` equal to 1, the decoding process for generating unavailable reference pictures specified in 8.3.3 is invoked, which needs to be invoked only for the first slice segment of a picture.
 - `PicOutputFlag` is set as follows:
 - If the current picture is a RASL picture and `NoRaslOutputFlag` of the associated IRAP picture is equal to 1, `PicOutputFlag` is set equal to 0.
 - Otherwise, `PicOutputFlag` is set equal to `pic_output_flag`.
 - At the beginning of the decoding process for each P or B slice, the decoding process for reference picture lists construction specified in 8.3.4 is invoked for derivation of reference picture list 0 (`RefPicList0`) and, when decoding a B slice, reference picture list 1 (`RefPicList1`), and the decoding process for collocated picture and no backward prediction flag specified in 8.3.5 is invoked for derivation of the variables `ColPic` and `NoBackwardPredFlag`.
3. The processes in 8.4, 8.5, 8.6, and 8.7 specify decoding processes using syntax elements in all syntax structure layers. It is a requirement of bitstream conformance that the coded slices of the picture shall contain slice segment data for every coding tree unit of the picture, such that the division of the picture into slices, the division of the slices into slice segments, and the division of the slice segments into coding tree units each forms a partitioning of the picture.
 4. After all slices of the current picture have been decoded, the current decoded picture after the invocation of the in-loop filter process as specified in 8.7 is marked as “used for short-term reference”. When `TwoVersionsOfCurrDecPicFlag` is equal to 1, the current decoded picture before the invocation of the in-loop filter process as specified in 8.7 is marked as “unused for reference”.

8.2 NAL unit decoding process

Inputs to this process are NAL units of the current picture and their associated non-VCL NAL units.

Outputs of this process are the parsed RBSP syntax structures encapsulated within the NAL units.

The decoding process for each NAL unit extracts the RBSP syntax structure from the NAL unit and then parses the RBSP syntax structure.

8.3 Slice decoding process

8.3.1 Decoding process for picture order count

Output of this process is `PicOrderCntVal`, the picture order count of the current picture.

ISO/IEC 23008-2:2017(E)

Picture order counts are used to identify pictures, for deriving motion parameters in merge mode and motion vector prediction, and for decoder conformance checking (see C.5).

Each coded picture is associated with a picture order count variable, denoted as `PicOrderCntVal`.

When the current picture is not an IRAP picture with `NoRaslOutputFlag` equal to 1, the variables `prevPicOrderCntLsb` and `prevPicOrderCntMsb` are derived as follows:

- Let `prevTid0Pic` be the previous picture in decoding order that has `TemporalId` equal to 0 and that is not a RASL, RADL, or SLNR picture.
- The variable `prevPicOrderCntLsb` is set equal to `slice_pic_order_cnt_lsb` of `prevTid0Pic`.
- The variable `prevPicOrderCntMsb` is set equal to `PicOrderCntMsb` of `prevTid0Pic`.

The variable `PicOrderCntMsb` of the current picture is derived as follows:

- If the current picture is an IRAP picture with `NoRaslOutputFlag` equal to 1, `PicOrderCntMsb` is set equal to 0.
- Otherwise, `PicOrderCntMsb` is derived as follows:

```
if ( ( slice_pic_order_cnt_lsb < prevPicOrderCntLsb ) &&  
      ( ( prevPicOrderCntLsb - slice_pic_order_cnt_lsb ) >= ( MaxPicOrderCntLsb / 2 ) ) )  
    PicOrderCntMsb = prevPicOrderCntMsb + MaxPicOrderCntLsb  
else if ( ( slice_pic_order_cnt_lsb > prevPicOrderCntLsb ) &&  
          ( ( slice_pic_order_cnt_lsb - prevPicOrderCntLsb ) >= ( MaxPicOrderCntLsb / 2 ) ) )  
    PicOrderCntMsb = prevPicOrderCntMsb - MaxPicOrderCntLsb  
else  
    PicOrderCntMsb = prevPicOrderCntMsb
```

(8-1)

`PicOrderCntVal` is derived as follows:

$$\text{PicOrderCntVal} = \text{PicOrderCntMsb} + \text{slice_pic_order_cnt_lsb} \quad (8-2)$$

NOTE 1 All IDR pictures will have `PicOrderCntVal` equal to 0 since `slice_pic_order_cnt_lsb` is inferred to be 0 for IDR pictures and `prevPicOrderCntLsb` and `prevPicOrderCntMsb` are both set equal to 0.

The value of `PicOrderCntVal` shall be in the range of -2^{31} to $2^{31} - 1$, inclusive. In one CVS, the `PicOrderCntVal` values for any two coded pictures shall not be the same.

The function `PicOrderCnt(picX)` is specified as follows:

$$\text{PicOrderCnt}(\text{picX}) = \text{PicOrderCntVal of the picture picX} \quad (8-3)$$

The function `DiffPicOrderCnt(picA, picB)` is specified as follows:

$$\text{DiffPicOrderCnt}(\text{picA}, \text{picB}) = \text{PicOrderCnt}(\text{picA}) - \text{PicOrderCnt}(\text{picB}) \quad (8-4)$$

The bitstream shall not contain data that result in values of `DiffPicOrderCnt(picA, picB)` used in the decoding process that are not in the range of -2^{15} to $2^{15} - 1$, inclusive.

NOTE 2 Let X be the current picture and Y and Z be two other pictures in the same CVS, Y and Z are considered to be in the same output order direction from X when both `DiffPicOrderCnt(X, Y)` and `DiffPicOrderCnt(X, Z)` are positive or both are negative.

8.3.2 Decoding process for reference picture set

This process is invoked once per picture, after decoding of a slice header but prior to the decoding of any coding unit and prior to the decoding process for reference picture list construction for the slice as

specified in 8.3.4. This process may result in one or more reference pictures in the DPB being marked as “unused for reference” or “used for long-term reference”.

NOTE 1 The RPS is an absolute description of the reference pictures used in the decoding process of the current and future coded pictures. The RPS signalling is explicit in the sense that all reference pictures included in the RPS are listed explicitly.

A decoded picture in the DPB can be marked as “unused for reference”, “used for short-term reference”, or “used for long-term reference”, but only one among these three at any given moment during the operation of the decoding process. Assigning one of these markings to a picture implicitly removes another of these markings when applicable. When a picture is referred to as being marked as “used for reference”, this collectively refers to the picture being marked as “used for short-term reference” or “used for long-term reference” (but not both).

The variable `currPicLayerId` is set equal to `nuh_layer_id` of the current picture.

When the current picture is an IRAP picture with `NoRaslOutputFlag` equal to 1, all reference pictures with `nuh_layer_id` equal to `currPicLayerId` currently in the DPB (if any) are marked as “unused for reference”.

Short-term reference pictures are identified by their `PicOrderCntVal` values. Long-term reference pictures are identified either by their `PicOrderCntVal` values or their `slice_pic_order_cnt_lsb` values.

Five lists of picture order count values are constructed to derive the RPS. These five lists are `PocStCurrBefore`, `PocStCurrAfter`, `PocStFoll`, `PocLtCurr`, and `PocLtFoll`, with `NumPocStCurrBefore`, `NumPocStCurrAfter`, `NumPocStFoll`, `NumPocLtCurr`, and `NumPocLtFoll` number of elements, respectively. The five lists and the five variables are derived as follows:

- If the current picture is an IDR picture, `PocStCurrBefore`, `PocStCurrAfter`, `PocStFoll`, `PocLtCurr`, and `PocLtFoll` are all set to be empty, and `NumPocStCurrBefore`, `NumPocStCurrAfter`, `NumPocStFoll`, `NumPocLtCurr`, and `NumPocLtFoll` are all set equal to 0.
- Otherwise, the following applies:

```

for( i = 0, j = 0, k = 0; i < NumNegativePics[ CurrRpsIdx ]; i++ )
    if( UsedByCurrPicS0[ CurrRpsIdx ][ i ] )
        PocStCurrBefore[ j++ ] = PicOrderCntVal + DeltaPocS0[ CurrRpsIdx ][ i ]
    else
        PocStFoll[ k++ ] = PicOrderCntVal + DeltaPocS0[ CurrRpsIdx ][ i ]
NumPocStCurrBefore = j

for( i = 0, j = 0; i < NumPositivePics[ CurrRpsIdx ]; i++ )
    if( UsedByCurrPicS1[ CurrRpsIdx ][ i ] )
        PocStCurrAfter[ j++ ] = PicOrderCntVal + DeltaPocS1[ CurrRpsIdx ][ i ]
    else
        PocStFoll[ k++ ] = PicOrderCntVal + DeltaPocS1[ CurrRpsIdx ][ i ]
NumPocStCurrAfter = j
NumPocStFoll = k
for( i = 0, j = 0, k = 0; i < num_long_term_sps + num_long_term_pics; i++ ) {
    pocLt = PocLsbLt[ i ]
    if( delta_poc_msb_present_flag[ i ] )
        pocLt += PicOrderCntVal - DeltaPocMsbCycleLt[ i ] * MaxPicOrderCntLsb -
                PicOrderCntVal & ( MaxPicOrderCntLsb - 1 )
    if( UsedByCurrPicLt[ i ] ) {
        PocLtCurr[ j ] = pocLt
        CurrDeltaPocMsbPresentFlag[ j++ ] = delta_poc_msb_present_flag[ i ]
    } else {
        PocLtFoll[ k ] = pocLt
        FollDeltaPocMsbPresentFlag[ k++ ] = delta_poc_msb_present_flag[ i ]
    }
}

```

(8-5)

```

    }
  }
  NumPocLtCurr = j
  NumPocLtFoll = k

```

where $PicOrderCntVal$ is the picture order count of the current picture as specified in 8.3.1.

NOTE 2 A value of $CurrRpsIdx$ in the range of 0 to $num_short_term_ref_pic_sets - 1$, inclusive, indicates that a candidate short-term RPS from the active SPS for the current layer is being used, where $CurrRpsIdx$ is the index of the candidate short-term RPS into the list of candidate short-term RPSs signalled in the active SPS for the current layer. $CurrRpsIdx$ equal to $num_short_term_ref_pic_sets$ indicates that the short-term RPS of the current picture is directly signalled in the slice header.

For each i in the range of 0 to $NumPocLtCurr - 1$, inclusive, when $CurrDeltaPocMsbPresentFlag[i]$ is equal to 1, it is a requirement of bitstream conformance that the following conditions apply:

- There shall be no j in the range of 0 to $NumPocStCurrBefore - 1$, inclusive, for which $PocLtCurr[i]$ is equal to $PocStCurrBefore[j]$.
- There shall be no j in the range of 0 to $NumPocStCurrAfter - 1$, inclusive, for which $PocLtCurr[i]$ is equal to $PocStCurrAfter[j]$.
- There shall be no j in the range of 0 to $NumPocStFoll - 1$, inclusive, for which $PocLtCurr[i]$ is equal to $PocStFoll[j]$.
- There shall be no j in the range of 0 to $NumPocLtCurr - 1$, inclusive, where j is not equal to i , for which $PocLtCurr[i]$ is equal to $PocLtCurr[j]$.

For each i in the range of 0 to $NumPocLtFoll - 1$, inclusive, when $FollDeltaPocMsbPresentFlag[i]$ is equal to 1, it is a requirement of bitstream conformance that the following conditions apply:

- There shall be no j in the range of 0 to $NumPocStCurrBefore - 1$, inclusive, for which $PocLtFoll[i]$ is equal to $PocStCurrBefore[j]$.
- There shall be no j in the range of 0 to $NumPocStCurrAfter - 1$, inclusive, for which $PocLtFoll[i]$ is equal to $PocStCurrAfter[j]$.
- There shall be no j in the range of 0 to $NumPocStFoll - 1$, inclusive, for which $PocLtFoll[i]$ is equal to $PocStFoll[j]$.
- There shall be no j in the range of 0 to $NumPocLtFoll - 1$, inclusive, where j is not equal to i , for which $PocLtFoll[i]$ is equal to $PocLtFoll[j]$.
- There shall be no j in the range of 0 to $NumPocLtCurr - 1$, inclusive, for which $PocLtFoll[i]$ is equal to $PocLtCurr[j]$.

For each i in the range of 0 to $NumPocLtCurr - 1$, inclusive, when $CurrDeltaPocMsbPresentFlag[i]$ is equal to 0, it is a requirement of bitstream conformance that the following conditions apply:

- There shall be no j in the range of 0 to $NumPocStCurrBefore - 1$, inclusive, for which $PocLtCurr[i]$ is equal to $(PocStCurrBefore[j] \& (MaxPicOrderCntLsb - 1))$.
- There shall be no j in the range of 0 to $NumPocStCurrAfter - 1$, inclusive, for which $PocLtCurr[i]$ is equal to $(PocStCurrAfter[j] \& (MaxPicOrderCntLsb - 1))$.
- There shall be no j in the range of 0 to $NumPocStFoll - 1$, inclusive, for which $PocLtCurr[i]$ is equal to $(PocStFoll[j] \& (MaxPicOrderCntLsb - 1))$.

- There shall be no j in the range of 0 to $\text{NumPocLtCurr} - 1$, inclusive, where j is not equal to i , for which $\text{PocLtCurr}[i]$ is equal to $(\text{PocLtCurr}[j] \& (\text{MaxPicOrderCntLsb} - 1))$.

For each i in the range of 0 to $\text{NumPocLtFoll} - 1$, inclusive, when $\text{FollDeltaPocMsbPresentFlag}[i]$ is equal to 0, it is a requirement of bitstream conformance that the following conditions apply:

- There shall be no j in the range of 0 to $\text{NumPocStCurrBefore} - 1$, inclusive, for which $\text{PocLtFoll}[i]$ is equal to $(\text{PocStCurrBefore}[j] \& (\text{MaxPicOrderCntLsb} - 1))$.
- There shall be no j in the range of 0 to $\text{NumPocStCurrAfter} - 1$, inclusive, for which $\text{PocLtFoll}[i]$ is equal to $(\text{PocStCurrAfter}[j] \& (\text{MaxPicOrderCntLsb} - 1))$.
- There shall be no j in the range of 0 to $\text{NumPocStFoll} - 1$, inclusive, for which $\text{PocLtFoll}[i]$ is equal to $(\text{PocStFoll}[j] \& (\text{MaxPicOrderCntLsb} - 1))$.
- There shall be no j in the range of 0 to $\text{NumPocLtFoll} - 1$, inclusive, where j is not equal to i , for which $\text{PocLtFoll}[i]$ is equal to $(\text{PocLtFoll}[j] \& (\text{MaxPicOrderCntLsb} - 1))$.
- There shall be no j in the range of 0 to $\text{NumPocLtCurr} - 1$, inclusive, for which $\text{PocLtFoll}[i]$ is equal to $(\text{PocLtCurr}[j] \& (\text{MaxPicOrderCntLsb} - 1))$.

The variable NumPicTotalCurr is derived as specified in 7.4.7.2. It is a requirement of bitstream conformance that the following applies to the value of NumPicTotalCurr :

- If the current picture is a BLA or CRA picture, the value of NumPicTotalCurr shall be equal to $\text{pps_curr_pic_ref_enabled_flag}$.
- Otherwise, when the current picture contains a P or B slice, the value of NumPicTotalCurr shall not be equal to 0.

The RPS of the current picture consists of five RPS lists; $\text{RefPicSetStCurrBefore}$, $\text{RefPicSetStCurrAfter}$, RefPicSetStFoll , RefPicSetLtCurr and RefPicSetLtFoll . $\text{RefPicSetStCurrBefore}$, $\text{RefPicSetStCurrAfter}$, and RefPicSetStFoll are collectively referred to as the short-term RPS. RefPicSetLtCurr and RefPicSetLtFoll are collectively referred to as the long-term RPS.

NOTE 3 $\text{RefPicSetStCurrBefore}$, $\text{RefPicSetStCurrAfter}$, and RefPicSetLtCurr contain all reference pictures that may be used for inter prediction of the current picture and one or more pictures that follow the current picture in decoding order. RefPicSetStFoll and RefPicSetLtFoll consist of all reference pictures that are *not* used for inter prediction of the current picture but may be used in inter prediction for one or more pictures that follow the current picture in decoding order.

The derivation process for the RPS and picture marking are performed according to the following ordered steps:

1. The following applies:

```

for(  $i = 0$ ;  $i < \text{NumPocLtCurr}$ ;  $i++$  )
    if( ! $\text{CurrDeltaPocMsbPresentFlag}[i]$  )
        if( there is a reference picture picX in the DPB with
             $\text{PicOrderCntVal} \& (\text{MaxPicOrderCntLsb} - 1)$ 
                equal to  $\text{PocLtCurr}[i]$  and  $\text{nuh\_layer\_id}$  equal to  $\text{currPicLayerId}$  )
             $\text{RefPicSetLtCurr}[i] = \text{picX}$ 
        else
             $\text{RefPicSetLtCurr}[i] = \text{"no reference picture"}$ 
    else
        if( there is a reference picture picX in the DPB with  $\text{PicOrderCntVal}$  equal to  $\text{PocLtCurr}[i]$ 
            and  $\text{nuh\_layer\_id}$  equal to  $\text{currPicLayerId}$  )
             $\text{RefPicSetLtCurr}[i] = \text{picX}$ 

```

```

else
    RefPicSetLtCurr[ i ] = "no reference picture"
for( i = 0; i < NumPocLtFoll; i++ )
    if( !FollDeltaPocMsbPresentFlag[ i ] )
        if( there is a reference picture picX in the DPB with
            PicOrderCntVal & ( MaxPicOrderCntLsb - 1 )
                equal to PocLtFoll[ i ] and nuh_layer_id equal to currPicLayerId )
            RefPicSetLtFoll[ i ] = picX
        else
            RefPicSetLtFoll[ i ] = "no reference picture"
else
    if( there is a reference picture picX in the DPB with PicOrderCntVal equal to PocLtFoll[ i ]
        and nuh_layer_id equal to currPicLayerId )
        RefPicSetLtFoll[ i ] = picX
    else
        RefPicSetLtFoll[ i ] = "no reference picture"

```

2. All reference pictures that are included in RefPicSetLtCurr or RefPicSetLtFoll and have nuh_layer_id equal to currPicLayerId are marked as "used for long-term reference".
3. The following applies:

```

for( i = 0; i < NumPocStCurrBefore; i++ )
    if( there is a short-term reference picture picX in the DPB
        with PicOrderCntVal equal to PocStCurrBefore[ i ] and nuh_layer_id equal to
            currPicLayerId )
        RefPicSetStCurrBefore[ i ] = picX
    else
        RefPicSetStCurrBefore[ i ] = "no reference picture"

for( i = 0; i < NumPocStCurrAfter; i++ )
    if( there is a short-term reference picture picX in the DPB
        with PicOrderCntVal equal to PocStCurrAfter[ i ] and nuh_layer_id equal to
            currPicLayerId )
        RefPicSetStCurrAfter[ i ] = picX
    else
        RefPicSetStCurrAfter[ i ] = "no reference picture"

for( i = 0; i < NumPocStFoll; i++ )
    if( there is a short-term reference picture picX in the DPB
        with PicOrderCntVal equal to PocStFoll[ i ] and nuh_layer_id equal to currPicLayerId )
        RefPicSetStFoll[ i ] = picX
    else
        RefPicSetStFoll[ i ] = "no reference picture"

```

4. All reference pictures in the DPB that are not included in RefPicSetLtCurr, RefPicSetLtFoll, RefPicSetStCurrBefore, RefPicSetStCurrAfter, or RefPicSetStFoll and have nuh_layer_id equal to currPicLayerId are marked as "unused for reference".

NOTE 4 There can be one or more entries in the RPS lists that are equal to "no reference picture" because the corresponding pictures are not present in the DPB. Entries in RefPicSetStFoll or RefPicSetLtFoll that are equal to "no reference picture" should be ignored. An unintentional picture loss should be inferred for each entry in RefPicSetStCurrBefore, RefPicSetStCurrAfter, or RefPicSetLtCurr that is equal to "no reference picture".

NOTE 5 A picture cannot be included in more than one of the five RPS lists.

It is a requirement of bitstream conformance that the RPS is restricted as follows:

- There shall be no entry in RefPicSetStCurrBefore, RefPicSetStCurrAfter, or RefPicSetLtCurr for which one or more of the following are true:
 - The entry is equal to “no reference picture”.
 - The entry is an SLNR picture and has TemporalId equal to that of the current picture.
 - The entry is a picture that has TemporalId greater than that of the current picture.
- There shall be no entry in RefPicSetLtCurr or RefPicSetLtFoll for which the difference between the picture order count value of the current picture and the picture order count value of the entry is greater than or equal to 2^{24} .
- When the current picture is a TSA picture, there shall be no picture included in the RPS with TemporalId greater than or equal to the TemporalId of the current picture.
- When the current picture is an STSA picture, there shall be no picture included in RefPicSetStCurrBefore, RefPicSetStCurrAfter, or RefPicSetLtCurr that has TemporalId equal to that of the current picture.
- When the current picture is a picture that follows, in decoding order, an STSA picture that has TemporalId equal to that of the current picture, there shall be no picture that has TemporalId equal to that of the current picture included in RefPicSetStCurrBefore, RefPicSetStCurrAfter, or RefPicSetLtCurr that precedes the STSA picture in decoding order.
- When the current picture is a CRA picture, there shall be no picture included in the RPS that precedes, in output order or decoding order, any preceding IRAP picture in decoding order (when present).
- When the current picture is a trailing picture, there shall be no picture in RefPicSetStCurrBefore, RefPicSetStCurrAfter, or RefPicSetLtCurr that was generated by the decoding process for generating unavailable reference pictures as specified in 8.3.3.
- When the current picture is a trailing picture, there shall be no picture in the RPS that precedes the associated IRAP picture in output order or decoding order.
- When the current picture is a RADL picture, there shall be no picture included in RefPicSetStCurrBefore, RefPicSetStCurrAfter, or RefPicSetLtCurr that is any of the following:
 - A RASL picture
 - A picture that was generated by the decoding process for generating unavailable reference pictures as specified in 8.3.3
 - A picture that precedes the associated IRAP picture in decoding order
- When sps_temporal_id_nesting_flag is equal to 1, the following apply:
 - Let tIdA be the value of TemporalId of the current picture picA.
 - Any picture picB with TemporalId equal to tIdB that is less than or equal to tIdA shall not be included in RefPicSetStCurrBefore, RefPicSetStCurrAfter, or RefPicSetLtCurr of picA when there exists a picture picC that has TemporalId less than tIdB, follows picB in decoding order, and precedes picA in decoding order.

8.3.3 Decoding process for generating unavailable reference pictures

8.3.3.1 General decoding process for generating unavailable reference pictures

This process is invoked once per coded picture when the current picture is a BLA picture or is a CRA picture with NoRaslOutputFlag equal to 1.

NOTE This process is primarily specified only for the specification of syntax constraints for RASL pictures. The entire specification of the decoding process for RASL pictures associated with an IRAP picture that has NoRaslOutputFlag equal to 1 is included herein only for purposes of specifying constraints on the allowed syntax content of such RASL pictures. During the decoding process, any RASL pictures associated with an IRAP picture that has NoRaslOutputFlag equal to 1 may be ignored, as these pictures are not specified for output and have no effect on the decoding process of any other pictures that are specified for output. However, in HRD operations as specified in Annex C, RASL access units may need to be taken into consideration in derivation of CPB arrival and removal times.

When this process is invoked, the following apply:

- For each RefPicSetStFoll[i], with i in the range of 0 to NumPocStFoll – 1, inclusive, that is equal to “no reference picture”, a picture is generated as specified in 8.3.3.2, and the following apply:
 - The value of PicOrderCntVal for the generated picture is set equal to PocStFoll[i].
 - The value of PicOutputFlag for the generated picture is set equal to 0.
 - The generated picture is marked as “used for short-term reference”.
 - RefPicSetStFoll[i] is set to be the generated reference picture.
 - The value of nuh_layer_id for the generated picture is set equal to nuh_layer_id of the current picture.
- For each RefPicSetLtFoll[i], with i in the range of 0 to NumPocLtFoll – 1, inclusive, that is equal to “no reference picture”, a picture is generated as specified in 8.3.3.2, and the following apply:
 - The value of PicOrderCntVal for the generated picture is set equal to PocLtFoll[i].
 - The value of slice_pic_order_cnt_lsb for the generated picture is inferred to be equal to (PocLtFoll[i] & (MaxPicOrderCntLsb – 1)).
 - The value of PicOutputFlag for the generated picture is set equal to 0.
 - The generated picture is marked as “used for long-term reference”.
 - RefPicSetLtFoll[i] is set to be the generated reference picture.
 - The value of nuh_layer_id for the generated picture is set equal to nuh_layer_id of the current picture.

8.3.3.2 Generation of one unavailable picture

When this process is invoked, an unavailable picture is generated as follows:

- The value of each element in the sample array S_L for the picture is set equal to $1 \ll (\text{BitDepth}_Y - 1)$.
- When ChromaArrayType is not equal to 0, the value of each element in the sample arrays S_{Cb} and S_{Cr} for the picture is set equal to $1 \ll (\text{BitDepth}_C - 1)$.

- The prediction mode $\text{CuPredMode}[x][y]$ is set equal to MODE_INTRA for $x = 0..\text{pic_width_in_luma_samples} - 1, y = 0..\text{pic_height_in_luma_samples} - 1$.

8.3.4 Decoding process for reference picture lists construction

This process is invoked at the beginning of the decoding process for each P or B slice.

Reference pictures are addressed through reference indices as specified in 8.5.3.3.2. A reference index is an index into a reference picture list. When decoding a P slice, there is a single reference picture list RefPicList0 . When decoding a B slice, there is a second independent reference picture list RefPicList1 in addition to RefPicList0 .

At the beginning of the decoding process for each slice, the reference picture lists RefPicList0 and, for B slices, RefPicList1 are derived as follows.

If $\text{TwoVersionsOfCurrDecPicFlag}$ is equal to 1, let the variable currPic be the current decoded picture before the invocation of the in-loop filter process; otherwise ($\text{TwoVersionsOfCurrDecPicFlag}$ is equal to 0), let the variable currPic be the current decoded picture after the invocation of the in-loop filter process. The variable $\text{NumRpsCurrTempList0}$ is set equal to $\text{Max}(\text{num_ref_idx_l0_active_minus1} + 1, \text{NumPicTotalCurr})$ and the list RefPicListTemp0 is constructed as follows:

```

rIdx = 0
while( rIdx < NumRpsCurrTempList0 ) {
  for( i = 0; i < NumPocStCurrBefore && rIdx < NumRpsCurrTempList0; rIdx++, i++ )
    RefPicListTemp0[ rIdx ] = RefPicSetStCurrBefore[ i ]
  for( i = 0; i < NumPocStCurrAfter && rIdx < NumRpsCurrTempList0; rIdx++, i++ )
    RefPicListTemp0[ rIdx ] = RefPicSetStCurrAfter[ i ]
  for( i = 0; i < NumPocLtCurr && rIdx < NumRpsCurrTempList0; rIdx++, i++ )
    RefPicListTemp0[ rIdx ] = RefPicSetLtCurr[ i ]
  if( pps_curr_pic_ref_enabled_flag )
    RefPicListTemp0[ rIdx++ ] = currPic
}

```

The list RefPicList0 is constructed as follows:

```

for( rIdx = 0; rIdx <= num_ref_idx_l0_active_minus1; rIdx++ )
  RefPicList0[ rIdx ] = ref_pic_list_modification_flag_l0 ? RefPicListTemp0[ list_entry_l0[ rIdx ] ] :
    RefPicListTemp0[ rIdx ]
if( pps_curr_pic_ref_enabled_flag && !ref_pic_list_modification_flag_l0 &&
    NumRpsCurrTempList0 > ( num_ref_idx_l0_active_minus1 + 1 ) )
  RefPicList0[ num_ref_idx_l0_active_minus1 ] = currPic

```

When the slice is a B slice, the variable $\text{NumRpsCurrTempList1}$ is set equal to $\text{Max}(\text{num_ref_idx_l1_active_minus1} + 1, \text{NumPicTotalCurr})$ and the list RefPicListTemp1 is constructed as follows:

```

rIdx = 0
while( rIdx < NumRpsCurrTempList1 ) {
  for( i = 0; i < NumPocStCurrAfter && rIdx < NumRpsCurrTempList1; rIdx++, i++ )
    RefPicListTemp1[ rIdx ] = RefPicSetStCurrAfter[ i ]
  for( i = 0; i < NumPocStCurrBefore && rIdx < NumRpsCurrTempList1; rIdx++, i++ )
    RefPicListTemp1[ rIdx ] = RefPicSetStCurrBefore[ i ]
  for( i = 0; i < NumPocLtCurr && rIdx < NumRpsCurrTempList1; rIdx++, i++ )
    RefPicListTemp1[ rIdx ] = RefPicSetLtCurr[ i ]
  if( pps_curr_pic_ref_enabled_flag )
    RefPicListTemp1[ rIdx++ ] = currPic
}

```

When the slice is a B slice, the list RefPicList1 is constructed as follows:

$$\begin{aligned} \text{for(rIdx = 0; rIdx} \leq \text{num_ref_idx_l1_active_minus1; rIdx++)} & \quad (8-11) \\ \text{RefPicList1[rIdx]} &= \text{ref_pic_list_modification_flag_l1 ? RefPicListTemp1[list_entry_l1[rIdx]] :} \\ & \quad \text{RefPicListTemp1[rIdx]} \end{aligned}$$

It is a requirement of bitstream conformance that when nuh_layer_id is equal to 0, nal_unit_type has a value in the range of BLA_W_LP to RSV_IRAP_VCL23, inclusive (i.e. the picture is an IRAP picture), pps_curr_pic_ref_enabled_flag is equal to 1, and slice_type is not equal to 2, RefPicList0 and RefPicList1 shall not contain entries that refer to a picture other than the current picture.

8.3.5 Decoding process for collocated picture and no backward prediction flag

This process is invoked at the beginning of the decoding process for each P or B slice, after decoding of the slice header as well as the invocation of the decoding process for reference picture set as specified in 8.3.2 and the invocation of the decoding process for reference picture list construction for the slice as specified in 8.3.4, but prior to the decoding of any coding unit.

When slice_temporal_mvp_enabled_flag is equal to 1, the variable ColPic is derived as follows:

- If slice_type is equal to B and collocated_from_l0_flag is equal to 0, ColPic is set equal to RefPicList1[collocated_ref_idx].
- Otherwise (slice_type is equal to B and collocated_from_l0_flag is equal to 1, or slice_type is equal to P), ColPic is set equal to RefPicList0[collocated_ref_idx].

The variable NoBackwardPredFlag is derived as follows:

- If DiffPicOrderCnt(aPic, CurrPic) is less than or equal to 0 for each picture aPic in RefPicList0 or RefPicList1 of the current slice, NoBackwardPredFlag is set equal to 1.
- Otherwise, NoBackwardPredFlag is set equal to 0.

8.4 Decoding process for coding units coded in intra prediction mode

8.4.1 General decoding process for coding units coded in intra prediction mode

Inputs to this process are

- a luma location (xCb, yCb) specifying the top-left sample of the current luma coding block relative to the top-left luma sample of the current picture, and
- a variable log2CbSize specifying the size of the current luma coding block.

Output of this process is a modified reconstructed picture before deblocking filtering.

The derivation process for quantization parameters as specified in 8.6.1 is invoked with the luma location (xCb, yCb) as input.

A variable nCbS is set equal to $1 \ll \log_2 \text{CbSize}$.

When residual_adaptive_colour_transform_enabled_flag is equal to 1, the residual sample arrays resSamplesL, resSamplesCb, and resSamplesCr store the residual samples of the current coding unit.

Depending on the values of pcm_flag[xCb][yCb], palette_mode_flag[xCb][yCb], and IntraSplitFlag, the decoding process for luma samples is specified as follows:

- If pcm_flag[xCb][yCb] is equal to 1, the reconstructed picture is modified as follows:

$$\begin{aligned} S_L[xCb + i][yCb + j] &= \\ \text{pcm_sample_luma[(nCbS * j) + i]} &\ll (\text{BitDepth}_Y - \text{PcmBitDepth}_Y), \text{ with } i, j = 0..nCbS - 1 \end{aligned} \quad (8-12)$$

— Otherwise ($\text{pcm_flag}[x_{Cb}][y_{Cb}]$ is equal to 0), if $\text{palette_mode_flag}[x_{Cb}][y_{Cb}]$ is equal to 1, the following ordered steps apply:

1. The decoding process for palette intra blocks as specified in 8.4.4.2.7 is invoked with the luma location (x_{Cb}, y_{Cb}) , the variable cIdx set equal to 0, and nCbSX and nCbSY both set equal to nCbS as inputs, and the output is an $\text{nCbS} \times \text{nCbS}$ array of reconstructed palette sample values, $\text{recSamples}[x][y]$, $x, y = 0..nCbS - 1$.
2. The reconstructed picture is modified as follows for $x, y = 0..nCbS - 1$ and $y = 0..nCbS - 1$:
 - If $\text{palette_transpose_flag}$ is equal to 1, the following applies:

$$\text{SL}[x_{Cb} + x][y_{Cb} + y] = \text{recSamples}[y][x] \quad (8-13)$$

— Otherwise ($\text{palette_transpose_flag}$ is equal to 0), the following applies:

$$\text{SL}[x_{Cb} + x][y_{Cb} + y] = \text{recSamples}[x][y] \quad (8-14)$$

— Otherwise ($\text{pcm_flag}[x_{Cb}][y_{Cb}]$ is equal to 0, $\text{palette_mode_flag}[x_{Cb}][y_{Cb}]$ is equal to 0), if IntraSplitFlag is equal to 0, the following ordered steps apply:

1. The derivation process for the intra prediction mode as specified in 8.4.2 is invoked with the luma location (x_{Cb}, y_{Cb}) as input.
2. If $\text{residual_adaptive_colour_transform_enabled_flag}$ is equal to 1, the following apply:

— The general decoding process for intra blocks as specified in 8.4.4.1 is invoked with the luma location (x_{Cb}, y_{Cb}) , the variable log2TrafoSize set equal to log2CbSize , the variable trafoDepth set equal to 0, the variable predModeIntra set equal to $\text{IntraPredModeY}[x_{Cb}][y_{Cb}]$, the variable cIdx set equal to 0 and variable controlParaAct set equal to 1 as inputs, and the output is a modified residual sample array resSamplesL .

— The general decoding process for intra blocks as specified in 8.4.4.1 is invoked with the chroma location (x_{Cb}, y_{Cb}) , the variable log2TrafoSize set equal to log2CbSize , the variable trafoDepth set equal to 0, the variable predModeIntra set equal to IntraPredModeC , the variable cIdx set equal to 1 and variable controlParaAct set equal to 1 as inputs, and the output is a modified residual sample array resSamplesCb .

— The general decoding process for intra blocks as specified in 8.4.4.1 is invoked with the chroma location (x_{Cb}, y_{Cb}) , the variable log2TrafoSize set equal to log2CbSize , the variable trafoDepth set equal to 0, the variable predModeIntra set equal to IntraPredModeC , the variable cIdx set equal to 2 and variable controlParaAct set equal to 1 as inputs, and the output is a modified residual sample array resSamplesCr .

— The residual modification process for blocks using adaptive colour transform as specified in 8.6.8 is invoked with location (x_{Cb}, y_{Cb}) , the variable log2TrafoSize set equal to log2CbSize , the variable trafoDepth set equal to 0, the variable resSampleArrayL set equal to resSamplesL , the variable resSampleArrayCb set equal to resSamplesCb and the variable resSampleArrayCr set equal to resSamplesCr as inputs, and the outputs are modified versions of resSampleL , resSampleCb and resSampleCr .

3. The general decoding process for intra blocks as specified in 8.4.4.1 is invoked with the luma location (x_{Cb}, y_{Cb}) , the variable log2TrafoSize set equal to log2CbSize , the variable trafoDepth set equal to 0, the variable predModeIntra set equal to $\text{IntraPredModeY}[x_{Cb}][y_{Cb}]$, the variable cIdx set equal to 0, the variable controlParaAct set equal to $(\text{residual_adaptive_colour_transform_enabled_flag} ? 2 : 0)$, and the array resSamplesL when

ISO/IEC 23008-2:2017(E)

controlParaAct is equal to 2 as inputs, and the output is a modified reconstructed picture before deblocking filtering.

— Otherwise ($\text{pcm_flag}[x_{Cb}][y_{Cb}]$ is equal to 0, $\text{palette_mode_flag}[x_{Cb}][y_{Cb}]$ is equal to 0, and IntraSplitFlag is equal to 1), for the variable blkIdx proceeding over the values 0..3, the following ordered steps apply:

1. The variable x_{Pb} is set equal to $x_{Cb} + (n_{CbS} \gg 1) * (\text{blkIdx} \% 2)$.
2. The variable y_{Pb} is set equal to $y_{Cb} + (n_{CbS} \gg 1) * (\text{blkIdx} / 2)$.
3. The derivation process for the intra prediction mode as specified in 8.4.2 is invoked with the luma location (x_{Pb}, y_{Pb}) as input.
4. If $\text{residual_adaptive_colour_transform_enabled_flag}$ is equal to 1, the following apply:
 - The general decoding process for intra blocks as specified in 8.4.4.1 is invoked with the luma location (x_{Pb}, y_{Pb}) , the variable log2TrafoSize set equal to $\text{log2CbSize} - 1$, the variable trafoDepth set equal to 1, the variable predModeIntra set equal to $\text{IntraPredModeY}[x_{Pb}][y_{Pb}]$, the variable cIdx set equal to 0 and variable controlParaAct equal to 1 as inputs, and the output is a modified residual sample array resSamplesL .
 - The general decoding process for intra blocks as specified in 8.4.4.1 is invoked with the chroma location (x_{Pb}, y_{Pb}) , the variable log2TrafoSize set equal to $\text{log2CbSize} - 1$, the variable trafoDepth set equal to 1, the variable predModeIntra set equal to IntraPredModeC , the variable cIdx set equal to 1 and variable controlParaAct equal to 1 as inputs, and the output is a modified residual sample array resSamplesCb .
 - The general decoding process for intra blocks as specified in 8.4.4.1 is invoked with the chroma location (x_{Pb}, y_{Pb}) , the variable log2TrafoSize set equal to $\text{log2CbSize} - 1$, the variable trafoDepth set equal to 1, the variable predModeIntra set equal to IntraPredModeC , the variable cIdx set equal to 2 and variable controlParaAct set equal to 1 as inputs, and the output is a modified residual sample array resSamplesCr .
 - The residual modification process for blocks using adaptive colour transform as specified in 8.6.8 is invoked with location (x_{Cb}, y_{Cb}) , the variable log2TrafoSize set equal to $\text{log2CbSize} - 1$, the variable trafoDepth set equal to 1, the variable resSampleArrayL set equal to resSamplesL , the variable resSampleArrayCb set equal to resSamplesCb and the variable resSampleArrayCr set equal to resSamplesCr as inputs, and the outputs are modified versions of resSampleL , resSampleCb and resSampleCr .
5. The general decoding process for intra blocks as specified in 8.4.4.1 is invoked with the luma location (x_{Pb}, y_{Pb}) , the variable log2TrafoSize set equal to $\text{log2CbSize} - 1$, the variable trafoDepth set equal to 1, the variable predModeIntra set equal to $\text{IntraPredModeY}[x_{Pb}][y_{Pb}]$, the variable cIdx set equal to 0, the variable controlParaAct set equal to $(\text{residual_adaptive_colour_transform_enabled_flag} ? 2 : 0)$, and the array resSamplesL when controlParaAct is equal to 2 as inputs, and the output is a modified reconstructed picture before deblocking filtering.

When ChromaArrayType is not equal to 0, the following applies.

The variable log2CbSizeC is set equal to $\text{log2CbSize} - (\text{ChromaArrayType} = 3 ? 0 : 1)$.

Depending on the values of $\text{pcm_flag}[x_{Cb}][y_{Cb}]$ and IntraSplitFlag , the decoding process for chroma samples is specified as follows:

— If $\text{pcm_flag}[x_{Cb}][y_{Cb}]$ is equal to 1, the reconstructed picture is modified as follows:

$$S_{cb}[x_{Cb} / \text{SubWidthC} + i][y_{Cb} / \text{SubHeightC} + j] = \text{pcm_sample_chroma}[(n_{CbS} / \text{SubWidthC} * j) + i] \ll (\text{BitDepth}_c - \text{PcmBitDepth}_c),$$

with $i = 0..n_{CbS} / \text{SubWidthC} - 1$ and $j = 0..n_{CbS} / \text{SubHeightC} - 1$ (8-15)

$$S_{cr}[x_{Cb} / \text{SubWidthC} + i][y_{Cb} / \text{SubHeightC} + j] = \text{pcm_sample_chroma}[(n_{CbS} / \text{SubWidthC} * (j + n_{CbS} / \text{SubHeightC})) + i] \ll (\text{BitDepth}_c - \text{PcmBitDepth}_c),$$

with $i = 0..n_{CbS} / \text{SubWidthC} - 1$ and $j = 0..n_{CbS} / \text{SubHeightC} - 1$ (8-16)

— Otherwise ($\text{pcm_flag}[x_{Cb}][y_{Cb}]$ is equal to 0), if $\text{palette_mode_flag}[x_{Cb}][y_{Cb}]$ is equal to 1 the following ordered steps apply:

1. n_{CbSX} is set as follows:

— If $\text{palette_transpose_flag}$ is equal to 1, n_{CbSX} is set equal to $(n_{CbS} / \text{SubHeightC})$, n_{CbY} is set equal to $(n_{CbS} / \text{SubWidthC})$.

— Otherwise ($\text{palette_transpose_flag}$ is equal to 0) n_{CbSX} is set equal to $(n_{CbS} / \text{SubWidthC})$, n_{CbY} is set equal to $(n_{CbS} / \text{SubHeightC})$.

2. The decoding process for palette intra blocks as specified in 8.4.4.2.7 is invoked with the chroma location (x_{Cb}, y_{Cb}) , the variable cIdx set equal to 1, n_{CbSX} , and n_{CbSY} as inputs, and the output is an $(n_{CbS} / \text{SubWidthC}) \times (n_{CbS} / \text{SubHeightC})$ array of reconstructed palette sample values, $\text{recSamples}[x][y]$, $x = 0 \dots n_{CbS} / \text{SubWidthC} - 1$, $y = 0..n_{CbS} / \text{SubHeightC} - 1$, when $\text{palette_transpose_flag}$ is equal to 0, or an $(n_{CbS} / \text{SubHeightC}) \times (n_{CbS} / \text{SubWidthC})$ array of reconstructed palette sample values, $\text{recSamples}[x][y]$, $x = 0 \dots n_{CbS} / \text{SubHeightC} - 1$, $y = 0..n_{CbS} / \text{SubWidthC} - 1$ when $\text{palette_transpose_flag}$ is equal to 1.

3. The reconstructed picture is modified as follows:

— If $\text{palette_transpose_flag}$ is equal to 1, the following applies:

$$S_{cb}[x_{Cb} / \text{SubWidthC} + x][y_{Cb} / \text{SubHeightC} + y] = \text{recSamples}[y][x],$$

with $x = 0..n_{CbS} / \text{SubWidthC} - 1$ and $y = 0..n_{CbS} / \text{SubHeightC} - 1$ (8-17)

— Otherwise ($\text{palette_transpose_flag}$ is equal to 0), the following applies:

$$S_{cb}[x_{Cb} / \text{SubWidthC} + x][y_{Cb} / \text{SubHeightC} + y] = \text{recSamples}[x][y],$$

with $x = 0..n_{CbS} / \text{SubWidthC} - 1$ and $y = 0..n_{CbS} / \text{SubHeightC} - 1$ (8-18)

4. The decoding process for palette intra blocks as specified in 8.4.4.2.7 is invoked with the chroma location (x_{Cb}, y_{Cb}) , the variable cIdx set equal to 2, n_{CbSX} set equal to $n_{CbS} / \text{SubWidthC}$, and n_{CbSY} set equal to $n_{CbS} / \text{SubHeightC}$ as inputs, and the output is an $(n_{CbS} / \text{SubWidthC}) \times (n_{CbS} / \text{SubHeightC})$ array of reconstructed palette sample values, $\text{recSamples}[x][y]$, $x = 0..n_{CbS} / \text{SubWidthC} - 1$, $y = 0..n_{CbS} / \text{SubHeightC} - 1$, when $\text{palette_transpose_flag}$ is equal to 0, or an $(n_{CbS} / \text{SubHeightC}) \times (n_{CbS} / \text{SubWidthC})$ array of reconstructed palette sample values, $\text{recSamples}[x][y]$, $x = 0..n_{CbS} / \text{SubHeightC} - 1$, $y = 0..n_{CbS} / \text{SubWidthC} - 1$, when $\text{palette_transpose_flag}$ is equal to 1.

5. The reconstructed picture is modified as follows:

— If $\text{palette_transpose_flag}$ is equal to 1, the following applies:

$$S_{cr}[x_{Cb} / \text{SubWidthC} + x][y_{Cb} / \text{SubHeightC} + y] = \text{recSamples}[y][x],$$

with $x = 0..n_{CbS} / \text{SubWidthC} - 1$ and $y = 0..n_{CbS} / \text{SubHeightC} - 1$ (8-19)

— Otherwise (palette_transpose_flag is equal to 0), the following applies:

$$\begin{aligned} \text{SCr}[\text{xCb} / \text{SubWidthC} + \text{x}][\text{yCb} / \text{SubHeightC} + \text{y}] &= \text{recSamples}[\text{x}][\text{y}], \\ \text{with } \text{x} &= 0.. \text{nCbS} / \text{SubWidthC} - 1 \text{ and } \text{y} = 0.. \text{nCbS} / \text{SubHeightC} - 1 \end{aligned} \quad (8-20)$$

— Otherwise (pcm_flag[xCb][yCb] is equal to 0, palette_mode_flag[xCb][yCb] is equal to 0), if IntraSplitFlag is equal to 0 or ChromaArrayType is not equal to 3, the following ordered steps apply:

1. The derivation process for the chroma intra prediction mode as specified in 8.4.3 is invoked with the luma location (xCb, yCb) as input, and the output is the variable IntraPredModeC.
2. The general decoding process for intra blocks as specified in 8.4.4.1 is invoked with the chroma location (xCb / SubWidthC, yCb / SubHeightC), the variable log2TrafoSize set equal to log2CbSizeC, the variable trafoDepth set equal to 0, the variable predModeIntra set equal to IntraPredModeC, the variable cldx set equal to 1, the variable controlParaAct set equal to (residual_adaptive_colour_transform_enabled_flag ? 2 : 0), and the array resSamplesCb when controlParaAct is equal to 2 as inputs, and the output is a modified reconstructed picture before deblocking filtering.
3. The general decoding process for intra blocks as specified in 8.4.4.1 is invoked with the chroma location (xCb / SubWidthC, yCb / SubHeightC), the variable log2TrafoSize set equal to log2CbSizeC, the variable trafoDepth set equal to 0, the variable predModeIntra set equal to IntraPredModeC, the variable cldx set equal to 2, the variable controlParaAct set equal to (residual_adaptive_colour_transform_enabled_flag ? 2 : 0), and the array resSamplesCr when controlParaAct is equal to 2 as inputs, and the output is a modified reconstructed picture before deblocking filtering.

— Otherwise (pcm_flag[xCb][yCb] is equal to 0, palette_mode_flag[xCb][yCb] is equal to 0, IntraSplitFlag is equal to 1, and ChromaArrayType is equal to 3), for the variable blkIdx proceeding over the values 0..3, the following ordered steps apply:

1. The variable xPb is set equal to $\text{xCb} + (\text{nCbS} \gg 1) * (\text{blkIdx} \% 2)$.
2. The variable yPb is set equal to $\text{yCb} + (\text{nCbS} \gg 1) * (\text{blkIdx} / 2)$.
3. The derivation process for the chroma intra prediction mode as specified in 8.4.3 is invoked with the luma location (xPb, yPb) as input, and the output is the variable IntraPredModeC.
4. The general decoding process for intra blocks as specified in 8.4.4.1 is invoked with the chroma location (xPb, yPb), the variable log2TrafoSize set equal to $\text{log2CbSizeC} - 1$, the variable trafoDepth set equal to 1, the variable predModeIntra set equal to IntraPredModeC, the variable cldx set equal to 1, the variable controlParaAct set equal to (residual_adaptive_colour_transform_enabled_flag ? 2 : 0), and the array resSamplesCb when controlParaAct is equal to 2 as inputs, and the output is a modified reconstructed picture before deblocking filtering.
5. The general decoding process for intra blocks as specified in 8.4.4.1 is invoked with the chroma location (xPb, yPb), the variable log2TrafoSize set equal to $\text{log2CbSizeC} - 1$, the variable trafoDepth set equal to 1, the variable predModeIntra set equal to IntraPredModeC, the variable cldx set equal to 2, the variable controlParaAct set equal to (residual_adaptive_colour_transform_enabled_flag ? 2 : 0), and the array resSamplesCr when controlParaAct is equal to 2 as inputs, and the output is a modified reconstructed picture before deblocking filtering.

8.4.2 Derivation process for luma intra prediction mode

Input to this process is a luma location (x_{Pb} , y_{Pb}) specifying the top-left sample of the current luma prediction block relative to the top-left luma sample of the current picture.

In this process, the luma intra prediction mode $\text{IntraPredModeY}[x_{Pb}][y_{Pb}]$ is derived.

Table 8-1 specifies the value for the intra prediction mode and the associated names.

Table 8-1 — Specification of intra prediction mode and associated names

Intra prediction mode	Associated name
0	INTRA_PLANAR
1	INTRA_DC
2..34	INTRA_ANGULAR2..INTRA_ANGULAR34

$\text{IntraPredModeY}[x_{Pb}][y_{Pb}]$ labelled 0..34 represents directions of predictions as illustrated in Figure 8-1.

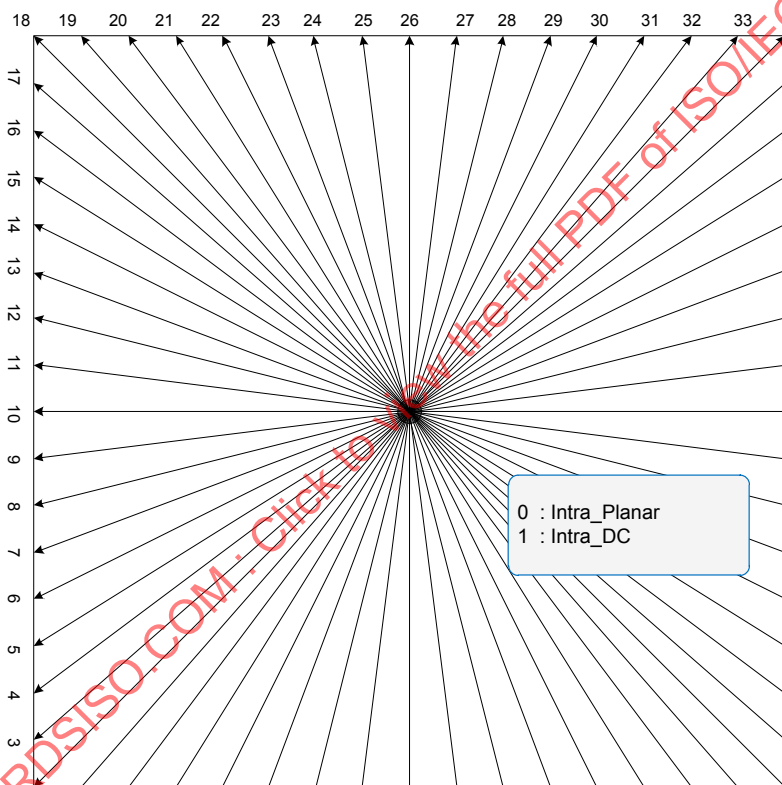

Figure 8-1 — Intra prediction mode directions (informative)

$\text{IntraPredModeY}[x_{Pb}][y_{Pb}]$ is derived by the following ordered steps:

1. The neighbouring locations (x_{NbA} , y_{NbA}) and (x_{NbB} , y_{NbB}) are set equal to ($x_{Pb} - 1$, y_{Pb}) and (x_{Pb} , $y_{Pb} - 1$), respectively.
2. For X being replaced by either A or B, the variables $\text{candIntraPredModeX}$ are derived as follows:
 - The availability derivation process for a block in z-scan order as specified in 6.4.1 is invoked with the location (x_{Curr} , y_{Curr}) set equal to (x_{Pb} , y_{Pb}) and the neighbouring location (x_{NbY} , y_{NbY}) set equal to (x_{NbX} , y_{NbX}) as inputs, and the output is assigned to availableX .

- The candidate intra prediction mode $\text{candIntraPredModeX}$ is derived as follows:
 - If availableX is equal to FALSE, $\text{candIntraPredModeX}$ is set equal to INTRA_DC.
 - Otherwise, if $\text{CuPredMode}[xNbX][yNbX]$ is not equal to MODE_INTRA or $\text{pcm_flag}[xNbX][yNbX]$ is equal to 1, $\text{candIntraPredModeX}$ is set equal to INTRA_DC.
 - Otherwise, if X is equal to B and $yPb - 1$ is less than $((yPb \gg \text{CtbLog2SizeY}) \ll \text{CtbLog2SizeY})$, $\text{candIntraPredModeB}$ is set equal to INTRA_DC.
 - Otherwise, $\text{candIntraPredModeX}$ is set equal to $\text{IntraPredModeY}[xNbX][yNbX]$.

3. The $\text{candModeList}[x]$ with $x = 0..2$ is derived as follows:

- If $\text{candIntraPredModeB}$ is equal to $\text{candIntraPredModeA}$, the following apply:
 - If $\text{candIntraPredModeA}$ is less than 2 (i.e. equal to INTRA_PLANAR or INTRA_DC), $\text{candModeList}[x]$ with $x = 0..2$ is derived as follows:

$$\text{candModeList}[0] = \text{INTRA_PLANAR} \quad (8-21)$$

$$\text{candModeList}[1] = \text{INTRA_DC} \quad (8-22)$$

$$\text{candModeList}[2] = \text{INTRA_ANGULAR26} \quad (8-23)$$

- Otherwise, $\text{candModeList}[x]$ with $x = 0..2$ is derived as follows:

$$\text{candModeList}[0] = \text{candIntraPredModeA} \quad (8-24)$$

$$\text{candModeList}[1] = 2 + ((\text{candIntraPredModeA} + 29) \% 32) \quad (8-25)$$

$$\text{candModeList}[2] = 2 + ((\text{candIntraPredModeA} - 2 + 1) \% 32) \quad (8-26)$$

- Otherwise ($\text{candIntraPredModeB}$ is not equal to $\text{candIntraPredModeA}$), the following apply:

- $\text{candModeList}[0]$ and $\text{candModeList}[1]$ are derived as follows:

$$\text{candModeList}[0] = \text{candIntraPredModeA} \quad (8-27)$$

$$\text{candModeList}[1] = \text{candIntraPredModeB} \quad (8-28)$$

- If neither of $\text{candModeList}[0]$ and $\text{candModeList}[1]$ is equal to INTRA_PLANAR, $\text{candModeList}[2]$ is set equal to INTRA_PLANAR.

- Otherwise, if neither of $\text{candModeList}[0]$ and $\text{candModeList}[1]$ is equal to INTRA_DC, $\text{candModeList}[2]$ is set equal to INTRA_DC.

- Otherwise, $\text{candModeList}[2]$ is set equal to INTRA_ANGULAR26.

4. $\text{IntraPredModeY}[xPb][yPb]$ is derived by applying the following procedure:

- If $\text{prev_intra_luma_pred_flag}[xPb][yPb]$ is equal to 1, the $\text{IntraPredModeY}[xPb][yPb]$ is set equal to $\text{candModeList}[\text{mpm_idx}[xPb][yPb]]$.

- Otherwise, $\text{IntraPredModeY}[xPb][yPb]$ is derived by applying the following ordered steps:

- 1) The array $\text{candModeList}[x]$, $x = 0..2$ is modified as the following ordered steps:

- i. When $\text{candModeList}[0]$ is greater than $\text{candModeList}[1]$, both values are swapped as follows:

$$(\text{candModeList}[0], \text{candModeList}[1]) = \text{Swap}(\text{candModeList}[0], \text{candModeList}[1]) \quad (8-29)$$

- ii. When $\text{candModeList}[0]$ is greater than $\text{candModeList}[2]$, both values are swapped as follows:

$$(\text{candModeList}[0], \text{candModeList}[2]) = \text{Swap}(\text{candModeList}[0], \text{candModeList}[2]) \quad (8-30)$$

- iii. When $\text{candModeList}[1]$ is greater than $\text{candModeList}[2]$, both values are swapped as follows:

$$(\text{candModeList}[1], \text{candModeList}[2]) = \text{Swap}(\text{candModeList}[1], \text{candModeList}[2]) \quad (8-31)$$

2) $\text{IntraPredModeY}[xPb][yPb]$ is derived by the following ordered steps:

- i. $\text{IntraPredModeY}[xPb][yPb]$ is set equal to $\text{rem_intra_luma_pred_mode}[xPb][yPb]$.
- ii. For i equal to 0 to 2, inclusive, when $\text{IntraPredModeY}[xPb][yPb]$ is greater than or equal to $\text{candModeList}[i]$, the value of $\text{IntraPredModeY}[xPb][yPb]$ is incremented by one.

8.4.3 Derivation process for chroma intra prediction mode

This process is only invoked when ChromaArrayType is not equal to 0.

Input to this process is a luma location (xPb, yPb) specifying the top-left sample of the current chroma prediction block relative to the top-left luma sample of the current picture.

Output of this process is the variable IntraPredModeC .

The variable modeIdx is derived using $\text{intra_chroma_pred_mode}[xPb][yPb]$ and $\text{IntraPredModeY}[xPb][yPb]$ as specified in Table 8-2.

The chroma intra prediction mode IntraPredModeC is derived as follows:

- If ChromaArrayType is equal to 2, IntraPredModeC is set using modeIdx as specified in Table 8-3.
- Otherwise, IntraPredModeC is set equal to modeIdx .

Table 8-2 — Specification of modeIdx

$\text{intra_chroma_pred_mode}[xPb][yPb]$	$\text{IntraPredModeY}[xPb][yPb]$				
	0	26	10	1	X ($0 \leq X \leq 34$)
0	34	0	0	0	0
1	26	34	26	26	26
2	10	10	34	10	10
3	1	1	1	34	1
4	0	26	10	1	X

Table 8-3 — Specification of intraPredModeC when ChromaArrayType is equal to 2

modeIdx	X <= 2	3	4	5	6	7	8	9	10	11	12	13	14	15	16	17	
IntraPredModeC	X	2	2	2	3	5	7	8	10	12	13	15	17	18	19	20	
modeIdx	18	19	20	21	22	23	24	25	26	27	28	29	30	31	32	33	34
IntraPredModeC	21	22	23	23	24	24	25	25	26	27	27	28	28	29	29	30	31

8.4.4 Decoding process for intra blocks

8.4.4.1 General decoding process for intra blocks

Inputs to this process are

- a sample location (xTb0, yTb0) specifying the top-left sample of the current transform block relative to the top-left sample of the current picture,
- a variable log2TrafoSize specifying the size of the current transform block,
- a variable trafoDepth specifying the hierarchy depth of the current block relative to the coding unit,
- a variable predModeIntra specifying the intra prediction mode,
- a variable cIdx specifying the colour component of the current block,
- a variable controlParaAct specifying the applicable processes, and
- when controlParaAct is equal to 2, a residual sample array resSamplesRec specifying the reconstructed residual samples for the current colour component of the current coding block.

Output of this process is a modified reconstructed picture before deblocking filtering when controlParaAct is not equal to 1, or a modified residual sample array resSampleArray for the current colour component of the current coding block when controlParaAct is equal to 1.

The luma sample location (xTbY, yTbY) specifying the top-left sample of the current luma transform block relative to the top-left luma sample of the current picture is derived as follows:

$$(xTbY, yTbY) = (cIdx = 0) ? (xTb0, yTb0) : (xTb0 * SubWidthC, yTb0 * SubHeightC) \quad (8-32)$$

The variable splitFlag is derived as follows:

- If cIdx is equal to 0, splitFlag is set equal to split_transform_flag[xTbY][yTbY][trafoDepth].
- Otherwise, if all of the following conditions are true, splitFlag is set equal to 1.
 - cIdx is greater than 0.
 - split_transform_flag[xTbY][yTbY][trafoDepth] is equal to 1.
 - log2TrafoSize is greater than 2.
- Otherwise, splitFlag is set equal to 0.

Depending on the value of splitFlag, the following apply:

- If splitFlag is equal to 1, the following ordered steps apply:
 1. The variables xTb1 and yTb1 are derived as follows:

- If $cIdx$ is equal to 0 or $ChromaArrayType$ is not equal to 2, the following apply:
 - The variable $xTb1$ is set equal to $xTb0 + (1 \ll (\log_2TrafoSize - 1))$.
 - The variable $yTb1$ is set equal to $yTb0 + (1 \ll (\log_2TrafoSize - 1))$.
 - Otherwise ($ChromaArrayType$ is equal to 2 and $cIdx$ is greater than 0), the following apply:
 - The variable $xTb1$ is set equal to $xTb0 + (1 \ll (\log_2TrafoSize - 1))$.
 - The variable $yTb1$ is set equal to $yTb0 + (2 \ll (\log_2TrafoSize - 1))$.
2. The general decoding process for intra blocks as specified in this subclause is invoked with the location $(xTb0, yTb0)$, the variable $\log_2TrafoSize$ set equal to $\log_2TrafoSize - 1$, the variable $trafoDepth$ set equal to $trafoDepth + 1$, the intra prediction mode $predModelIntra$, the variable $cIdx$, the variable $controlParaAct$, and the array $resSamplesRec$ when $controlParaAct$ is equal to 2 as inputs, and the output is a modified reconstructed picture before deblocking filtering when $controlParaAct$ is not equal to 1 or a modified residual sample array $resSampleArray$ when $controlParaAct$ is equal to 1.
 3. The general decoding process for intra blocks as specified in this subclause is invoked with the location $(xTb1, yTb0)$, the variable $\log_2TrafoSize$ set equal to $\log_2TrafoSize - 1$, the variable $trafoDepth$ set equal to $trafoDepth + 1$, the intra prediction mode $predModelIntra$, the variable $cIdx$, the variable $controlParaAct$, and the array $resSamplesRec$ when $controlParaAct$ is equal to 2 as inputs, and the output is a modified reconstructed picture before deblocking filtering when $controlParaAct$ is not equal to 1 or a modified residual sample array $resSampleArray$ when $controlParaAct$ is equal to 1.
 4. The general decoding process for intra blocks as specified in this subclause is invoked with the location $(xTb0, yTb1)$, the variable $\log_2TrafoSize$ set equal to $\log_2TrafoSize - 1$, the variable $trafoDepth$ set equal to $trafoDepth + 1$, the intra prediction mode $predModelIntra$, the variable $cIdx$, the variable $controlParaAct$, and the array $resSamplesRec$ when $controlParaAct$ is equal to 2 as inputs, and the output is a modified reconstructed picture before deblocking filtering when $controlParaAct$ is not equal to 1 or a modified residual sample array $resSampleArray$ when $controlParaAct$ is equal to 1.
 5. The general decoding process for intra blocks as specified in this subclause is invoked with the location $(xTb1, yTb1)$, the variable $\log_2TrafoSize$ set equal to $\log_2TrafoSize - 1$, the variable $trafoDepth$ set equal to $trafoDepth + 1$, the intra prediction mode $predModelIntra$, the variable $cIdx$, the variable $controlParaAct$, and the array $resSamplesRec$ when $controlParaAct$ is equal to 2 as inputs, and the output is a modified reconstructed picture before deblocking filtering when $controlParaAct$ is not equal to 1 or a modified residual sample array $resSampleArray$ when $controlParaAct$ is equal to 1.
- Otherwise ($splitFlag$ is equal to 0), for the variable $blkIdx$ proceeding over the values $0..(cIdx > 0 \ \&\& \ ChromaArrayType = 2 ? 1 : 0)$, the following ordered steps apply:
 1. The variable $nTbS$ is set equal to $1 \ll \log_2TrafoSize$.
 2. The variable $yTbOffset$ is set equal to $blkIdx * nTbS$.
 3. The variable $yTbOffsetY$ is set equal to $yTbOffset * SubHeightC$.
 4. When $controlParaAct$ is not equal to 2, the variable $residualDpcm$ is derived as follows:
 - If all of the following conditions are true, $residualDpcm$ is set equal to 1.

- `implicit_rdp_pcm_enabled_flag` is equal to 1.
 - either `transform_skip_flag[xTbY][yTbY + yTbOffsetY][cIdx]` is equal to 1, or `cu_transquant_bypass_flag` is equal to 1.
 - either `predModeIntra` is equal to 10, or `predModeIntra` is equal to 26.
 - Otherwise, `residualDpcm` is set equal to 0.
5. When `controlParaAct` is not equal to 1, the general intra sample prediction process as specified in 8.4.4.2.1 is invoked with the transform block location (`xTb0, yTb0 + yTbOffset`), the intra prediction mode `predModeIntra`, the transform block size `nTbS`, and the variable `cIdx` as inputs, and the output is an $(nTbS) \times (nTbS)$ array `predSamples`.
 6. When `controlParaAct` is not equal to 2, the scaling and transformation process as specified in 8.6.2 is invoked with the luma location (`xTbY, yTbY + yTbOffsetY`), the variable `trafoDepth`, the variable `cIdx`, and the transform size `trafoSize` set equal to `nTbS` as inputs, and the output is an $(nTbS) \times (nTbS)$ array `resSamples`.
 7. When `controlParaAct` is not equal to 2 and `residualDpcm` is equal to 1, the directional residual modification process for blocks using a transform bypass as specified in 8.6.5 is invoked with the variable `mDir` set equal to `predModeIntra / 26`, the variable `nTbS`, and the $(nTbS) \times (nTbS)$ array `r` set equal to the array `resSamples` as inputs, and the output is a modified $(nTbS) \times (nTbS)$ array `resSamples`.
 8. When `controlParaAct` is not equal to 2 and `cross_component_prediction_enabled_flag` is equal to 1, `ChromaArrayType` is equal to 3, and `cIdx` is not equal to 0, the residual modification process for transform blocks using cross-component prediction as specified in 8.6.6 is invoked with the current luma transform block location (`xTbY, yTbY`), the variable `nTbS`, the variable `cIdx`, the $(nTbS) \times (nTbS)$ array `rv` set equal to the corresponding luma residual sample array `resSamples` of the current transform block, and the $(nTbS) \times (nTbS)$ array `r` set equal to the array `resSamples` as inputs, and the output is a modified $(nTbS) \times (nTbS)$ array `resSamples`.
 9. When `controlParaAct` is not equal to 0, the following apply:
 - The variable `nCbS` specifying the size of the current coding block is derived by setting `nCbS` equal to $1 \ll (\log_2 \text{TrafoSize} + \text{trafDepth})$.
 - The sample location (`xTbInCb, yTbInCb`) specifying the top-left sample of the current transform block relative to the top-left sample of the current coding block is derived by setting `xTbInCb` equal to `xTb0 & (nCbS - 1)` and setting `yTbInCb` equal to `yTb0 & (nCbS - 1)`.
 10. When `controlParaAct` is equal to 2, the $(nTbS) \times (nTbS)$ array `resSamples` is derived by setting `resSamples[x][y]` equal to `resSamplesRec[x + xTbInCb][y + yTbInCb]`, for `x` and `y` in the range of 0 to `nTbS - 1`, inclusive.
 11. The following apply:
 - If `controlParaAct` is equal to 1, the residual array `resSamplesArray` is modified by setting `resSamplesArray[x + xTbInCb][y + yTbInCb]` equal to `resSamples[x][y]`, for `x` and `y` in the range of 0 to `nTbS - 1`, inclusive.
 - Otherwise (`controlParaAct` is not equal to 1), the picture construction process prior to in-loop filtering for a colour component as specified in 8.6.7 is invoked with the transform block location (`xTb0, yTb0 + yTbOffset`), the variables `nCurrSw` and `nCurrSh` both set

equal to $nTbS$, the variable $cIdx$, the $(nTbS) \times (nTbS)$ array $predSamples$, and the $(nTbS) \times (nTbS)$ array $resSamples$ as inputs.

8.4.4.2 Intra sample prediction

8.4.4.2.1 General intra sample prediction

Inputs to this process are

- a sample location $(xTbCmp, yTbCmp)$ specifying the top-left sample of the current transform block relative to the top-left sample of the current picture,
- a variable $predModeIntra$ specifying the intra prediction mode,
- a variable $nTbS$ specifying the transform block size, and
- a variable $cIdx$ specifying the colour component of the current block.

Outputs of this process are the predicted samples $predSamples[x][y]$, with $x, y = 0..nTbS - 1$.

The $nTbS * 4 + 1$ neighbouring samples $p[x][y]$ that are constructed samples prior to the deblocking filter process, with $x = -1, y = -1..nTbS * 2 - 1$ and $x = 0..nTbS * 2 - 1, y = -1$ are derived as follows:

- The neighbouring location $(xNbCmp, yNbCmp)$ is specified by:

$$(xNbCmp, yNbCmp) = (xTbCmp + x, yTbCmp + y) \quad (8-33)$$

- The current luma location $(xTbY, yTbY)$ and the neighbouring luma location $(xNbY, yNbY)$ are derived as follows:

$$(xTbY, yTbY) = (cIdx == 0) ? (xTbCmp, yTbCmp) : (xTbCmp * SubWidthC, yTbCmp * SubHeightC) \quad (8-34)$$

$$(xNbY, yNbY) = (cIdx == 0) ? (xNbCmp, yNbCmp) : (xNbCmp * SubWidthC, yNbCmp * SubHeightC) \quad (8-35)$$

- The availability derivation process for a block in z-scan order as specified in 6.4.1 is invoked with the current luma location $(xCurr, yCurr)$ set equal to $(xTbY, yTbY)$ and the neighbouring luma location $(xNbY, yNbY)$ as inputs, and the output is assigned to $availableN$.
- Each sample $p[x][y]$ is derived as follows:
 - If one or more of the following conditions are true, the sample $p[x][y]$ is marked as "not available for intra prediction":
 - The variable $availableN$ is equal to FALSE.
 - $CuPredMode[xNbY][yNbY]$ is not equal to `MODE_INTRA` and `constrained_intra_pred_flag` is equal to 1.
 - Otherwise, the sample $p[x][y]$ is marked as "available for intra prediction" and the sample at the location $(xNbCmp, yNbCmp)$ is assigned to $p[x][y]$.

When at least one sample $p[x][y]$ with $x = -1, y = -1..nTbS * 2 - 1$ and $x = 0..nTbS * 2 - 1, y = -1$ is marked as "not available for intra prediction", the reference sample substitution process for intra sample prediction in 8.4.4.2.2 is invoked with the samples $p[x][y]$ with $x = -1, y = -1..nTbS * 2 - 1$ and $x = 0..nTbS * 2 - 1, y = -1, nTbS$, and $cIdx$ as inputs, and the modified samples $p[x][y]$ with $x = -1, y = -1..nTbS * 2 - 1$ and $x = 0..nTbS * 2 - 1, y = -1$ as output.

Depending on the value of `predModeIntra`, the following ordered steps apply:

1. When `intra_smoothing_disabled_flag` is equal to 0 and either `cIdx` is equal to 0 or `ChromaArrayType` is equal to 3, the filtering process of neighbouring samples specified in 8.4.4.2.3 is invoked with the sample array `p`, the transform block size `nTbS`, and the colour component index `cIdx` as inputs, and the output is reassigned to the sample array `p`.
2. The intra sample prediction process according to `predModeIntra` applies as follows:
 - If `predModeIntra` is equal to `INTRA_PLANAR`, the corresponding intra prediction mode specified in 8.4.4.2.4 is invoked with the sample array `p` and the transform block size `nTbS` as inputs, and the output is the predicted sample array `predSamples`.
 - Otherwise, if `predModeIntra` is equal to `INTRA_DC`, the corresponding intra prediction mode specified in 8.4.4.2.5 is invoked with the sample array `p`, the transform block size `nTbS`, and the colour component index `cIdx` as inputs, and the output is the predicted sample array `predSamples`.
 - Otherwise (`predModeIntra` is in the range of `INTRA_ANGULAR2..INTRA_ANGULAR34`), the corresponding intra prediction mode specified in 8.4.4.2.6 is invoked with the intra prediction mode `predModeIntra`, the sample array `p`, the transform block size `nTbS`, and the colour component index `cIdx` as inputs, and the output is the predicted sample array `predSamples`.

8.4.4.2.2 Reference sample substitution process for intra sample prediction

Inputs to this process are

- reference samples `p[x][y]` with $x = -1, y = -1..nTbS * 2 - 1$ and $x = 0..nTbS * 2 - 1, y = -1$ for intra sample prediction,
- a transform block size `nTbS`,
- a variable `cIdx` specifying the colour component of the current block, and
- a variable `cIdx` specifying the colour component of the current block.

Outputs of this process are the modified reference samples `p[x][y]` with $x = -1, y = -1..nTbS * 2 - 1$ and $x = 0..nTbS * 2 - 1, y = -1$ for intra sample prediction.

The variable `bitDepth` is derived as follows:

- If `cIdx` is equal to 0, `bitDepth` is set equal to `BitDepthv`.
- Otherwise, `bitDepth` is set equal to `BitDepthc`.

The values of the samples `p[x][y]` with $x = -1, y = -1..nTbS * 2 - 1$ and $x = 0..nTbS * 2 - 1, y = -1$ are modified as follows:

- If all samples `p[x][y]` with $x = -1, y = -1..nTbS * 2 - 1$ and $x = 0..nTbS * 2 - 1, y = -1$ are marked as "not available for intra prediction", the value $1 \ll (\text{bitDepth} - 1)$ is substituted for the values of all samples `p[x][y]`.
- Otherwise (at least one but not all samples `p[x][y]` are marked as "not available for intra prediction"), the following ordered steps are performed.
 1. When `p[-1][nTbS * 2 - 1]` is marked as "not available for intra prediction", search sequentially starting from $x = -1, y = nTbS * 2 - 1$ to $x = -1, y = -1$, then from $x = 0, y = -1$ to $x = nTbS * 2 - 1, y = -1$. Once a sample `p[x][y]` marked as "available for intra prediction" is found, the search is terminated and the value of `p[x][y]` is assigned to `p[-1][nTbS * 2 - 1]`.

2. Search sequentially starting from $x = -1, y = nTbS * 2 - 2$ to $x = -1, y = -1$, when $p[x][y]$ is marked as “not available for intra prediction”, the value of $p[x][y + 1]$ is substituted for the value of $p[x][y]$.
3. For $x = 0..nTbS * 2 - 1, y = -1$, when $p[x][y]$ is marked as “not available for intra prediction”, the value of $p[x - 1][y]$ is substituted for the value of $p[x][y]$.

All samples $p[x][y]$ with $x = -1, y = -1..nTbS * 2 - 1$ and $x = 0..nTbS * 2 - 1, y = -1$ are marked as “available for intra prediction”.

8.4.4.2.3 Filtering process of neighbouring samples

Inputs to this process are

- the neighbouring samples $p[x][y]$, with $x = -1, y = -1..nTbS * 2 - 1$ and $x = 0..nTbS * 2 - 1, y = -1$, and
- a variable $nTbS$ specifying the transform block size.

Outputs of this process are the filtered samples $pF[x][y]$, with $x = -1, y = -1..nTbS * 2 - 1$ and $x = 0..nTbS * 2 - 1, y = -1$.

The variable $filterFlag$ is derived as follows:

- If one or more of the following conditions are true, $filterFlag$ is set equal to 0:
 - $predModeIntra$ is equal to `INTRA_DC`.
 - $nTbS$ is equal to 4.
- Otherwise, the following apply:
 - The variable $minDistVerHor$ is set equal to $\text{Min}(\text{Abs}(\text{predModeIntra} - 26), \text{Abs}(\text{predModeIntra} - 10))$.
 - The variable $intraHorVerDistThres[nTbS]$ is specified in Table 8-4.
 - The variable $filterFlag$ is derived as follows:
 - If $minDistVerHor$ is greater than $intraHorVerDistThres[nTbS]$, $filterFlag$ is set equal to 1.
 - Otherwise, $filterFlag$ is set equal to 0.

Table 8-4 — Specification of $intraHorVerDistThres[nTbS]$ for various transform block sizes

	$nTbS = 8$	$nTbS = 16$	$nTbS = 32$
$intraHorVerDistThres[nTbS]$	7	1	0

When $filterFlag$ is equal to 1, the following apply:

- The variable $biIntFlag$ is derived as follows:
 - If all of the following conditions are true, $biIntFlag$ is set equal to 1:
 - $strong_intra_smoothing_enabled_flag$ is equal to 1.
 - $cIdx$ is equal to 0.
 - $nTbS$ is equal to 32.

- $\text{Abs}(p[-1][-1] + p[nTbS * 2 - 1][-1] - 2 * p[nTbS - 1][-1])$ is less than $1 \ll (\text{BitDepth}_Y - 5)$.
- $\text{Abs}(p[-1][-1] + p[-1][nTbS * 2 - 1] - 2 * p[-1][nTbS - 1])$ is less than $1 \ll (\text{BitDepth}_Y - 5)$.
- Otherwise, `biIntFlag` is set equal to 0.

— The filtering is performed as follows:

- If `biIntFlag` is equal to 1, the filtered sample values $pF[x][y]$ with $x = -1, y = -1..63$ and $x = 0..63, y = -1$ are derived as follows:

$$pF[-1][-1] = p[-1][-1] \quad (8-36)$$

$$pF[-1][y] = ((63 - y) * p[-1][-1] + (y + 1) * p[-1][63] + 32) \gg 6 \text{ for } y = 0..62 \quad (8-37)$$

$$pF[-1][63] = p[-1][63] \quad (8-38)$$

$$pF[x][-1] = ((63 - x) * p[-1][-1] + (x + 1) * p[63][-1] + 32) \gg 6 \text{ for } x = 0..62 \quad (8-39)$$

$$pF[63][-1] = p[63][-1] \quad (8-40)$$

- Otherwise (`biIntFlag` is equal to 0), the filtered sample values $pF[x][y]$ with $x = -1, y = -1..nTbS * 2 - 1$ and $x = 0..nTbS * 2 - 1, y = -1$ are derived as follows:

$$pF[-1][-1] = (p[-1][0] + 2 * p[-1][-1] + p[0][-1] + 2) \gg 2 \quad (8-41)$$

$$pF[-1][y] = (p[-1][y + 1] + 2 * p[-1][y] + p[-1][y - 1] + 2) \gg 2 \text{ for } y = 0..nTbS * 2 - 2 \quad (8-42)$$

$$pF[-1][nTbS * 2 - 1] = p[-1][nTbS * 2 - 1] \quad (8-43)$$

$$pF[x][-1] = (p[x - 1][-1] + 2 * p[x][-1] + p[x + 1][-1] + 2) \gg 2 \text{ for } x = 0..nTbS * 2 - 2 \quad (8-44)$$

$$pF[nTbS * 2 - 1][-1] = p[nTbS * 2 - 1][-1] \quad (8-45)$$

8.4.4.2.4 Specification of intra prediction mode INTRA_PLANAR

Inputs to this process are

- the neighbouring samples $p[x][y]$, with $x = -1, y = -1..nTbS * 2 - 1$ and $x = 0..nTbS * 2 - 1, y = -1$, and
- a variable `nTbS` specifying the transform block size.

Outputs of this process are the predicted samples $\text{predSamples}[x][y]$, with $x, y = 0..nTbS - 1$.

The values of the prediction samples $\text{predSamples}[x][y]$, with $x, y = 0..nTbS - 1$, are derived as follows:

$$\text{predSamples}[x][y] = ((nTbS - 1 - x) * p[-1][y] + (x + 1) * p[nTbS][-1] + (nTbS - 1 - y) * p[x][-1] + (y + 1) * p[-1][nTbS] + nTbS) \gg (\text{Log}_2(nTbS) + 1) \quad (8-46)$$

8.4.4.2.5 Specification of intra prediction mode INTRA_DC

Inputs to this process are

- the neighbouring samples $p[x][y]$, with $x = -1, y = -1..nTbS * 2 - 1$ and $x = 0..nTbS * 2 - 1, y = -1$,
- a variable $nTbS$ specifying the transform block size, and
- a variable $cIdx$ specifying the colour component of the current block.

Outputs of this process are the predicted samples $predSamples[x][y]$, with $x, y = 0..nTbS - 1$.

The values of the prediction samples $predSamples[x][y]$, with $x, y = 0..nTbS - 1$, are derived by the following ordered steps:

1. A variable $dcVal$ is derived as follows:

$$dcVal = \left(\sum_{x'=0}^{nTbS-1} p[x'][-1] + \sum_{y'=0}^{nTbS-1} p[-1][y'] + nTbS \right) \gg (k + 1) \quad (8-47)$$

where $k = \text{Log}_2(nTbS)$.

2. Depending on the value of the colour component index $cIdx$, the following apply:

- If $cIdx$ is equal to 0, `intra_boundary_filtering_disabled` flag is equal to 0, and $nTbS$ is less than 32, the following apply:

$$predSamples[0][0] = (p[-1][0] + 2 * dcVal + p[0][-1] + 2) \gg 2 \quad (8-48)$$

$$predSamples[x][0] = (p[x][-1] + 3 * dcVal + 2) \gg 2, \text{ with } x = 1..nTbS - 1 \quad (8-49)$$

$$predSamples[0][y] = (p[-1][y] + 3 * dcVal + 2) \gg 2, \text{ with } y = 1..nTbS - 1 \quad (8-50)$$

$$predSamples[x][y] = dcVal, \text{ with } x, y = 1..nTbS - 1 \quad (8-51)$$

- Otherwise, the prediction samples $predSamples[x][y]$ are derived as follows:

$$predSamples[x][y] = dcVal, \text{ with } x, y = 0..nTbS - 1 \quad (8-52)$$

8.4.4.2.6 Specification of intra prediction mode in the range of INTRA_ANGULAR2..INTRA_ANGULAR34

Inputs to this process are

- the intra prediction mode `predModeIntra`,
- the neighbouring samples $p[x][y]$, with $x = -1, y = -1..nTbS * 2 - 1$ and $x = 0..nTbS * 2 - 1, y = -1$,
- a variable $nTbS$ specifying the transform block size, and
- a variable $cIdx$ specifying the colour component of the current block.

Outputs of this process are the predicted samples $predSamples[x][y]$, with $x, y = 0..nTbS - 1$.

Figure 8-2 illustrates the total 33 intra angles and Table 8-5 specifies the mapping table between `predModeIntra` and the angle parameter `intraPredAngle`.

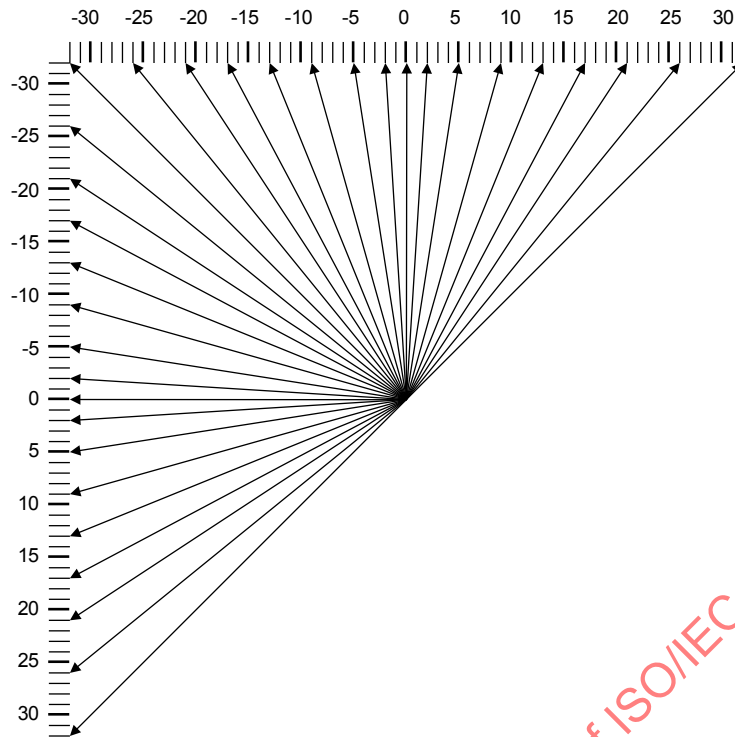

Figure 8-2 — Intra prediction angle definition (informative)

Table 8-5 — Specification of intraPredAngle

predModeIntra	1	2	3	4	5	6	7	8	9	10	11	12	13	14	15	16	17
intraPredAngle	—	32	26	21	17	13	9	5	2	0	-2	-5	-9	-13	-17	-21	-26
predModeIntra	18	19	20	21	22	23	24	25	26	27	28	29	30	31	32	33	34
intraPredAngle	-32	-26	-21	-17	-13	-9	-5	-2	0	2	5	9	13	17	21	26	32

Table 8-6 further specifies the mapping table between predModeIntra and the inverse angle parameter invAngle.

Table 8-6 — Specification of invAngle

predModeIntra	11	12	13	14	15	16	17	18
invAngle	-4096	-1638	-910	-630	-482	-390	-315	-256
predModeIntra	19	20	21	22	23	24	25	26
invAngle	-315	-390	-482	-630	-910	-1638	-4096	-

The variable disableIntraBoundaryFilter is derived as follows:

- If intra_boundary_filtering_disabled_flag is equal to 1, disableIntraBoundaryFilter is set equal to 1.
- Otherwise (intra_boundary_filtering_disabled_flag is equal to 0), if implicit_rdpkm_enabled_flag and cu_transquant_bypass_flag are both equal to 1, disableIntraBoundaryFilter is set equal to 1.
- Otherwise, disableIntraBoundaryFilter is set equal to 0.

The values of the prediction samples predSamples[x][y], with x, y = 0..nTbS - 1 are derived as follows:

- If predModeIntra is greater than or equal to 18, the following ordered steps apply:

1. The reference sample array $\text{ref}[x]$ is specified as follows:

— The following applies:

$$\text{ref}[x] = p[-1+x][-1], \text{ with } x = 0..nTbS \quad (8-53)$$

— If intraPredAngle is less than 0, the main reference sample array is extended as follows:

— When $(nTbS * \text{intraPredAngle}) \gg 5$ is less than -1,

$$\text{ref}[x] = p[-1][-1 + ((x * \text{invAngle} + 128) \gg 8)], \\ \text{ with } x = -1..(nTbS * \text{intraPredAngle}) \gg 5 \quad (8-54)$$

— Otherwise,

$$\text{ref}[x] = p[-1+x][-1], \text{ with } x = nTbS + 1..2 * nTbS \quad (8-55)$$

2. The values of the prediction samples $\text{predSamples}[x][y]$, with $x, y = 0..nTbS - 1$ are derived as follows:

- a. The index variable $iIdx$ and the multiplication factor $iFact$ are derived as follows:

$$iIdx = ((y + 1) * \text{intraPredAngle}) \gg 5 \quad (8-56)$$

$$iFact = ((y + 1) * \text{intraPredAngle}) \& 31 \quad (8-57)$$

- b. Depending on the value of $iFact$, the following apply:

— If $iFact$ is not equal to 0, the value of the prediction samples $\text{predSamples}[x][y]$ is derived as follows:

$$\text{predSamples}[x][y] = \\ ((32 - iFact) * \text{ref}[x + iIdx + 1] + iFact * \text{ref}[x + iIdx + 2] + 16) \gg 5 \quad (8-58)$$

— Otherwise, the value of the prediction samples $\text{predSamples}[x][y]$ is derived as follows:

$$\text{predSamples}[x][y] = \text{ref}[x + iIdx + 1] \quad (8-59)$$

- c. When predModeIntra is equal to 26 (vertical), $cIdx$ is equal to 0, $nTbS$ is less than 32, and $\text{disableIntraBoundaryFilter}$ is equal to 0, the following filtering applies with $x = 0, y = 0..nTbS - 1$:

$$\text{predSamples}[x][y] = \text{Clip1}_v(p[x][-1] + ((p[-1][y] - p[-1][-1]) \gg 1)) \quad (8-60)$$

— Otherwise (predModeIntra is less than 18), the following ordered steps apply:

1. The reference sample array $\text{ref}[x]$ is specified as follows:

— The following applies:

$$\text{ref}[x] = p[-1][-1+x], \text{ with } x = 0..nTbS \quad (8-61)$$

— If intraPredAngle is less than 0, the main reference sample array is extended as follows:

— When $(nTbS * \text{intraPredAngle}) \gg 5$ is less than -1,

$$\text{ref}[x] = p[-1 + ((x * \text{invAngle} + 128) \gg 8)][-1],$$

with $x = -1..(nTbS * \text{intraPredAngle}) \gg 5$

(8-62)

— Otherwise,

$$\text{ref}[x] = p[-1][-1 + x], \text{ with } x = nTbS + 1..2 * nTbS$$
(8-63)

2. The values of the prediction samples $\text{predSamples}[x][y]$, with $x, y = 0..nTbS - 1$ are derived as follows:

a. The index variable $iIdx$ and the multiplication factor $iFact$ are derived as follows:

$$iIdx = ((x + 1) * \text{intraPredAngle}) \gg 5$$
(8-64)

$$iFact = ((x + 1) * \text{intraPredAngle}) \& 31$$
(8-65)

b. Depending on the value of $iFact$, the following apply:

— If $iFact$ is not equal to 0, the value of the prediction samples $\text{predSamples}[x][y]$ is derived as follows:

$$\text{predSamples}[x][y] = ((32 - iFact) * \text{ref}[y + iIdx + 1] + iFact * \text{ref}[y + iIdx + 2] + 16) \gg 5$$
(8-66)

— Otherwise, the value of the prediction samples $\text{predSamples}[x][y]$ is derived as follows:

$$\text{predSamples}[x][y] = \text{ref}[y + iIdx + 1]$$
(8-67)

c. When predModelIntra is equal to 10 (horizontal), $cIdx$ is equal to 0, $nTbS$ is less than 32, and $\text{disableIntraBoundaryFilter}$ is equal to 0, the following filtering applies with $x = 0..nTbS - 1, y = 0$:

$$\text{predSamples}[x][y] = \text{Clip1}_Y(p[-1][y] + (((p[x][-1] - p[-1][-1]) \gg 1)))$$
(8-68)

8.4.4.2.7 Decoding process for palette mode

Inputs to this process are

- a location (xCb, yCb) specifying the top-left luma sample of the current block relative to the top-left luma sample of the current picture,
- a variable $cIdx$ specifying the colour component of the current block, and
- two variables $nCbSX$ and $nCbSY$ specifying the width and height of the current block, respectively.

Output of this process is an array $\text{recSamples}[x][y]$, with $x = 0..nCbSX - 1, y = 0..nCbSY - 1$ specifying reconstructed sample values for the block.

Depending on the value of $cIdx$, the variables $nSubWidth$ and $nSubHeight$ are derived as follows:

- If $cIdx$ is equal to 0, $nSubWidth$ is set to 1 and $nSubHeight$ is set to 1.
- Otherwise, $nSubWidth$ is set to SubWidthC and $nSubHeight$ is set to SubHeightC .

The $(nCbSX \times nCbSY)$ block of the reconstructed sample array recSamples at location (xCb, yCb) is represented by $\text{recSamples}[x][y]$ with $x = 0..nCbSX - 1$ and $y = 0..nCbSY - 1$, and the value of $\text{recSamples}[x][y]$ for each x in the range of 0 to $nCbSX - 1$, inclusive, and each y in the range of 0 to $nCbSY - 1$, inclusive, is derived as follows:

— The variables x_L and y_L are derived as follows:

$$x_L = \text{palette_transpose_flag} ? x * \text{nSubHeight} : x * \text{nSubWidth} \quad (8-69)$$

$$y_L = \text{palette_transpose_flag} ? y * \text{nSubWidth} : y * \text{nSubHeight} \quad (8-70)$$

— The variable bIsEscapeSample is derived as follows:

— If $\text{PaletteIndexMap}[x_{Cb} + x_L][y_{Cb} + y_L]$ is equal to MaxPaletteIndex and $\text{palette_escape_val_present_flag}$ is equal to 1, bIsEscapeSample is set equal to 1.

— Otherwise, bIsEscapeSample is set equal to 0.

— If bIsEscapeSample is equal to 0, the following applies:

$$\text{recSamples}[x][y] = \text{CurrentPaletteEntries}[cIdx][\text{PaletteIndexMap}[x_{Cb} + x_L][y_{Cb} + y_L]] \quad (8-71)$$

— Otherwise, if $\text{cu_transquant_bypass_flag}$ is equal to 1, the following applies:

$$\text{recSamples}[x][y] = \text{PaletteEscapeVal}[cIdx][x_{Cb} + x_L][y_{Cb} + y_L] \quad (8-72)$$

— Otherwise (bIsEscapeSample is equal to 1 and $\text{cu_transquant_bypass_flag}$ is equal to 0), the following ordered steps apply:

1. The derivation process for quantization parameters as specified in 8.6.1 is invoked with the location (x_{Cb}, y_{Cb}) specifying the top-left sample of the current block relative to the top-left sample of the current picture.

2. The quantization parameter q_P is derived as follows:

— If $cIdx$ is equal to 0,

$$q_P = \text{Max}(0, Q_P'Y) \quad (8-73)$$

— Otherwise, if $cIdx$ is equal to 1,

$$q_P = \text{Max}(0, Q_P'Cb) \quad (8-74)$$

— Otherwise ($cIdx$ is equal to 2),

$$q_P = \text{Max}(0, Q_P'Cr) \quad (8-75)$$

3. The variables bitDepth is derived as follows:

$$\text{bitDepth} = (cIdx == 0) ? \text{BitDepth}_Y : \text{BitDepth}_c \quad (8-76)$$

4. The list $\text{levelScale}[]$ is specified as $\text{levelScale}[k] = \{40, 45, 51, 57, 64, 72\}$ with $k = 0..5$.

5. The following apply:

$$\text{tmpVal} = (\text{PaletteEscapeVal}[cIdx][x_{Cb} + x_L][y_{Cb} + y_L] * \text{levelScale}[q_P \% 6]) \ll ((q_P / 6) + 32) \gg 6 \quad (8-77)$$

$$\text{recSamples}[x][y] = \text{Clip3}(0, (1 \ll \text{bitDepth}) - 1, \text{tmpVal}) \quad (8-78)$$

The variable $\text{PredictorPaletteSize}$ and the array $\text{PredictorPaletteEntries}$ are derived or modified as follows:

```

numComps = ( ChromaArrayType == 0 ) ? 1 : 3
for( i = 0; i < CurrentPaletteSize; i++ )
    for( cIdx = 0; cIdx < numComps; cIdx++ )
        newPredictorPaletteEntries[ cIdx ][ i ] = CurrentPaletteEntries[ cIdx ][ i ]
newPredictorPaletteSize = CurrentPaletteSize
for( i = 0; i < PredictorPaletteSize && newPredictorPaletteSize < PaletteMaxPredictorSize; i++ )
    if( !PalettePredictorEntryReuseFlags[ i ] ) {
        for( cIdx = 0; cIdx < numComps; cIdx++ )
            newPredictorPaletteEntries[ cIdx ][ newPredictorPaletteSize ] =
                PredictorPaletteEntries[ cIdx ][ i ]
        newPredictorPaletteSize++
    }
for( cIdx = 0; cIdx < numComps; cIdx++ )
    for( i = 0; i < newPredictorPaletteSize; i++ )
        PredictorPaletteEntries[ cIdx ][ i ] = newPredictorPaletteEntries[ cIdx ][ i ]
PredictorPaletteSize = newPredictorPaletteSize

```

(8-79)

It is a requirement of bitstream conformance that the value of PredictorPaletteSize shall be in the range of 0 to PaletteMaxPredictorSize, inclusive.

8.5 Decoding process for coding units coded in inter prediction mode

8.5.1 General decoding process for coding units coded in inter prediction mode

Inputs to this process are

- a luma location (xCb, yCb) specifying the top-left sample of the current luma coding block relative to the top-left luma sample of the current picture, and
- a variable log2CbSize specifying the size of the current coding block.

Output of this process is a modified reconstructed picture before deblocking filtering.

The derivation process for quantization parameters as specified in 8.6.1 is invoked with the luma location (xCb, yCb) as input.

The variable nCbSL is set equal to $1 \ll \log_2 \text{CbSize}$. When ChromaArrayType is not equal to 0, the variable nCbSwC is set equal to $(1 \ll \log_2 \text{CbSize}) / \text{SubWidthC}$ and the variable nCbShC is set equal to $(1 \ll \log_2 \text{CbSize}) / \text{SubHeightC}$.

The decoding process for coding units coded in inter prediction mode consists of following ordered steps:

1. The inter prediction process as specified in 8.5.2 is invoked with the luma location (xCb, yCb) and the luma coding block size log2CbSize as inputs, and the outputs are the array predSamplesL and, when ChromaArrayType is not equal to 0, the arrays predSamplesCb and predSamplesCr.
2. The decoding process for the residual signal of coding units coded in inter prediction mode specified in 8.5.4 is invoked with the luma location (xCb, yCb) and the luma coding block size log2CbSize as inputs, and the outputs are the array resSamplesL and, when ChromaArrayType is not equal to 0, the arrays resSamplesCb and resSamplesCr.
3. The reconstructed samples of the current coding unit are derived as follows:
 - The picture construction process prior to in-loop filtering for a colour component as specified in 8.6.7 is invoked with the luma coding block location (xCb, yCb), the variable nCurrSw set equal to nCbSL, the variable nCurrSh set equal to nCbSL, the variable cIdx set equal to 0, the $(nCbSL) \times (nCbSL)$ array predSamples set equal to predSamplesL, and the $(nCbSL) \times (nCbSL)$ array resSamples set equal to resSamplesL as inputs.

- When ChromaArrayType is not equal to 0, the picture construction process prior to in-loop filtering for a colour component as specified in 8.6.7 is invoked with the chroma coding block location (x_{Cb} / SubWidthC, y_{Cb} / SubHeightC), the variable nCurrSw set equal to n_{CbSw_C} , the variable nCurrSh set equal to n_{CbSh_C} , the variable cIdx set equal to 1, the $(n_{CbSw_C}) \times (n_{CbSh_C})$ array predSamples set equal to $predSamples_{Cb}$, and the $(n_{CbSw_C}) \times (n_{CbSh_C})$ array resSamples set equal to $resSamples_{Cb}$ as inputs.
- When ChromaArrayType is not equal to 0, the picture construction process prior to in-loop filtering for a colour component as specified in 8.6.7 is invoked with the chroma coding block location (x_{Cb} / SubWidthC, y_{Cb} / SubHeightC), the variable nCurrSw set equal to n_{CbSw_C} , the variable nCurrSh set equal to n_{CbSh_C} , the variable cIdx set equal to 2, the $(n_{CbSw_C}) \times (n_{CbSh_C})$ array predSamples set equal to $predSamples_{Cr}$, and the $(n_{CbSw_C}) \times (n_{CbSh_C})$ array resSamples set equal to $resSamples_{Cr}$ as inputs.

8.5.2 Inter prediction process

This process is invoked when decoding coding unit whose $CuPredMode[x_{Cb}][y_{Cb}]$ is not equal to MODE_INTRA.

Inputs to this process are

- a luma location (x_{Cb} , y_{Cb}) specifying the top-left sample of the current luma coding block relative to the top-left luma sample of the current picture, and
- a variable log2CbSize specifying the size of the current luma coding block.

Outputs of this process are

- an $(n_{CbS_L}) \times (n_{CbS_L})$ array $predSamples_L$ of luma prediction samples, where n_{CbS_L} is derived as specified below,
- when ChromaArrayType is not equal to 0, an $(n_{CbSw_C}) \times (n_{CbSh_C})$ array $predSamples_{Cb}$ of chroma prediction samples for the component Cb, where n_{CbSw_C} and n_{CbSh_C} are derived as specified below, and
- when ChromaArrayType is not equal to 0, an $(n_{CbSw_C}) \times (n_{CbSh_C})$ array $predSamples_{Cr}$ of chroma prediction samples for the component Cr, where n_{CbSw_C} and n_{CbSh_C} are derived as specified below.

The variable n_{CbS_L} is set equal to $1 \ll \log_2 CbSize$. When ChromaArrayType is not equal to 0, the variable n_{CbSw_C} is set equal to $n_{CbS_L} / SubWidthC$ and the variable n_{CbSh_C} is set equal to $n_{CbS_L} / SubHeightC$.

The variable $n_{CbS_{1L}}$ is set equal to $n_{CbS_L} \gg 1$.

Depending on the value of PartMode, the following apply:

- If PartMode is equal to PART_2Nx2N, the decoding process for prediction units in inter prediction mode as specified in 8.5.3 is invoked with the luma location (x_{Cb} , y_{Cb}), the luma location (x_{Bl} , y_{Bl}) set equal to (0, 0), the size of the luma coding block n_{CbS_L} , the width of the luma prediction block n_{PbW} set equal to n_{CbS_L} , the height of the luma prediction block n_{PbH} set equal to n_{CbS_L} , and a partition index partIdx set equal to 0 as inputs, and the outputs are an $(n_{CbS_L}) \times (n_{CbS_L})$ array $predSamples_L$ and, when ChromaArrayType is not equal to 0, two $(n_{CbSw_C}) \times (n_{CbSh_C})$ arrays $predSamples_{Cb}$ and $predSamples_{Cr}$.
- Otherwise, if PartMode is equal to PART_2NxN, the following ordered steps apply:
 1. The decoding process for prediction units in inter prediction mode as specified in 8.5.3 is invoked with the luma location (x_{Cb} , y_{Cb}), the luma location (x_{Bl} , y_{Bl}) set equal to (0, 0),

the size of the luma coding block $nCbS_L$, the width of the luma prediction block $nPbW$ set equal to $nCbS_L$, the height of the luma prediction block $nPbH$ set equal to $nCbS_L \gg 1$, and a partition index $partIdx$ set equal to 0 as inputs, and the outputs are an $(nCbS_L) \times (nCbS_L)$ array $predSamples_L$ and, when $ChromaArrayType$ is not equal to 0, two $(nCbSw_C) \times (nCbSh_C)$ arrays $predSamples_{Cb}$ and $predSamples_{Cr}$.

2. The decoding process for prediction units in inter prediction mode as specified in 8.5.3 is invoked with the luma location (xCb, yCb) , the luma location (xBl, yBl) set equal to $(0, nCbS_L \gg 1)$, the size of the luma coding block $nCbS_L$, the width of the luma prediction block $nPbW$ set equal to $nCbS_L$, the height of the luma prediction block $nPbH$ set equal to $nCbS_L \gg 1$, and a partition index $partIdx$ set equal to 1 as inputs, and the outputs are the modified $(nCbS_L) \times (nCbS_L)$ array $predSamples_L$ and, when $ChromaArrayType$ is not equal to 0, the two modified $(nCbSw_C) \times (nCbSh_C)$ arrays $predSamples_{Cb}$ and $predSamples_{Cr}$.

— Otherwise, if $PartMode$ is equal to $PART_Nx2N$, the following ordered steps apply:

1. The decoding process for prediction units in inter prediction mode as specified in 8.5.3 is invoked with the luma location (xCb, yCb) , the luma location (xBl, yBl) set equal to $(0, 0)$, the size of the luma coding block $nCbS_L$, the width of the luma prediction block $nPbW$ set equal to $nCbS_L \gg 1$, the height of the luma prediction block $nPbH$ set equal to $nCbS_L$, and a partition index $partIdx$ set equal to 0 as inputs, and the outputs are an $(nCbS_L) \times (nCbS_L)$ array $predSamples_L$ and, when $ChromaArrayType$ is not equal to 0, two $(nCbSw_C) \times (nCbSh_C)$ arrays $predSamples_{Cb}$ and $predSamples_{Cr}$.
2. The decoding process for prediction units in inter prediction mode as specified in 8.5.3 is invoked with the luma location (xCb, yCb) , the luma location (xBl, yBl) set equal to $(nCbS_L \gg 1, 0)$, the size of the luma coding block $nCbS_L$, the width of the luma prediction block $nPbW$ set equal to $nCbS_L \gg 1$, the height of the luma prediction block $nPbH$ set equal to $nCbS_L$, and a partition index $partIdx$ set equal to 1 as inputs, and the outputs are the modified $(nCbS_L) \times (nCbS_L)$ array $predSamples_L$ and, when $ChromaArrayType$ is not equal to 0, the two modified $(nCbSw_C) \times (nCbSh_C)$ arrays $predSamples_{Cb}$ and $predSamples_{Cr}$.

— Otherwise, if $PartMode$ is equal to $PART_2Nx nU$, the following ordered steps apply:

1. The decoding process for prediction units in inter prediction mode as specified in 8.5.3 is invoked with the luma location (xCb, yCb) , the luma location (xBl, yBl) set equal to $(0, 0)$, the size of the luma coding block $nCbS_L$, the width of the luma prediction block $nPbW$ set equal to $nCbS_L$, the height of the luma prediction block $nPbH$ set equal to $nCbS_L \gg 2$, and a partition index $partIdx$ set equal to 0 as inputs, and the outputs are an $(nCbS_L) \times (nCbS_L)$ array $predSamples_L$ and, when $ChromaArrayType$ is not equal to 0, two $(nCbSw_C) \times (nCbSh_C)$ arrays $predSamples_{Cb}$ and $predSamples_{Cr}$.
2. The decoding process for prediction units in inter prediction mode as specified in 8.5.3 is invoked with the luma location (xCb, yCb) , the luma location (xBl, yBl) set equal to $(0, nCbS_L \gg 2)$, the size of the luma coding block $nCbS_L$, the width of the luma prediction block $nPbW$ set equal to $nCbS_L$, the height of the luma prediction block $nPbH$ set equal to $(nCbS_L \gg 1) + (nCbS_L \gg 2)$, and a partition index $partIdx$ set equal to 1 as inputs, and the outputs are the modified $(nCbS_L) \times (nCbS_L)$ array $predSamples_L$ and, when $ChromaArrayType$ is not equal to 0, the two modified $(nCbSw_C) \times (nCbSh_C)$ arrays $predSamples_{Cb}$ and $predSamples_{Cr}$.

— Otherwise, if $PartMode$ is equal to $PART_2Nx nD$, the following ordered steps apply:

1. The decoding process for prediction units in inter prediction mode as specified in 8.5.3 is invoked with the luma location (xCb, yCb) , the luma location (xBl, yBl) set equal to $(0, 0)$, the size of the luma coding block $nCbS_L$, the width of the luma prediction block $nPbW$ set equal

to $nCbS_L$, the height of the luma prediction block $nPbH$ set equal to $(nCbS_L \gg 1) + (nCbS_L \gg 2)$, and a partition index $partIdx$ set equal to 0 as inputs, and the outputs are an $(nCbS_L) \times (nCbS_L)$ array $predSamples_L$ and, when $ChromaArrayType$ is not equal to 0, two $(nCbSw_C) \times (nCbSh_C)$ arrays $predSamples_{Cb}$ and $predSamples_{Cr}$.

2. The decoding process for prediction units in inter prediction mode as specified in 8.5.3 is invoked with the luma location (xCb, yCb) , the luma location (xBl, yBl) set equal to $(0, (nCbS_L \gg 1) + (nCbS_L \gg 2))$, the size of the luma coding block $nCbS_L$, the width of the luma prediction block $nPbW$ set equal to $nCbS_L$, the height of the luma prediction block $nPbH$ set equal to $nCbS_L \gg 2$, and a partition index $partIdx$ set equal to 1 as inputs, and the outputs are the modified $(nCbS_L) \times (nCbS_L)$ array $predSamples_L$ and, when $ChromaArrayType$ is not equal to 0, the two modified $(nCbSw_C) \times (nCbSh_C)$ arrays $predSamples_{Cb}$ and $predSamples_{Cr}$.

— Otherwise, if $PartMode$ is equal to $PART_nLx2N$, the following ordered steps apply:

1. The decoding process for prediction units in inter prediction mode as specified in 8.5.3 is invoked with the luma location (xCb, yCb) , the luma location (xBl, yBl) set equal to $(0, 0)$, the size of the luma coding block $nCbS_L$, the width of the luma prediction block $nPbW$ set equal to $nCbS_L \gg 2$, the height of the luma prediction block $nPbH$ set equal to $nCbS_L$, and a partition index $partIdx$ set equal to 0 as inputs, and the outputs are an $(nCbS_L) \times (nCbS_L)$ array $predSamples_L$ and, when $ChromaArrayType$ is not equal to 0, two $(nCbSw_C) \times (nCbSh_C)$ arrays $predSamples_{Cb}$ and $predSamples_{Cr}$.
2. The decoding process for prediction units in inter prediction mode as specified in 8.5.3 is invoked with the luma location (xCb, yCb) , the luma location (xBl, yBl) set equal to $(nCbS_L \gg 2, 0)$, the size of the luma coding block $nCbS_L$, the width of the luma prediction block $nPbW$ set equal to $(nCbS_L \gg 1) + (nCbS_L \gg 2)$, the height of the luma prediction block $nPbH$ set equal to $nCbS_L$, and a partition index $partIdx$ set equal to 1 as inputs, and the outputs are the modified $(nCbS_L) \times (nCbS_L)$ array $predSamples_L$ and, when $ChromaArrayType$ is not equal to 0, the two modified $(nCbSw_C) \times (nCbSh_C)$ arrays $predSamples_{Cb}$ and $predSamples_{Cr}$.

— Otherwise, if $PartMode$ is equal to $PART_nRx2N$, the following ordered steps apply:

1. The decoding process for prediction units in inter prediction mode as specified in 8.5.3 is invoked with the luma location (xCb, yCb) , the luma location (xBl, yBl) set equal to $(0, 0)$, the size of the luma coding block $nCbS_L$, the width of the luma prediction block $nPbW$ set equal to $(nCbS_L \gg 1) + (nCbS_L \gg 2)$, the height of the luma prediction block $nPbH$ set equal to $nCbS_L$, and a partition index $partIdx$ set equal to 0 as inputs, and the outputs are an $(nCbS_L) \times (nCbS_L)$ array $predSamples_L$ and, when $ChromaArrayType$ is not equal to 0, two $(nCbSw_C) \times (nCbSh_C)$ arrays $predSamples_{Cb}$ and $predSamples_{Cr}$.
2. The decoding process for prediction units in inter prediction mode as specified in 8.5.3 is invoked with the luma location (xCb, yCb) , the luma location (xBl, yBl) set equal to $(nCS1_L + (nCbS_L \gg 2), 0)$, the size of the luma coding block $nCbS_L$, the width of the luma prediction block $nPbW$ set equal to $nCbS_L \gg 2$, the height of the luma prediction block $nPbH$ set equal to $nCbS_L$, and a partition index $partIdx$ set equal to 1 as inputs, and the outputs are the modified $(nCbS_L) \times (nCbS_L)$ array $predSamples_L$ and, when $ChromaArrayType$ is not equal to 0, the two modified $(nCbSw_C) \times (nCbSh_C)$ arrays $predSamples_{Cb}$ and $predSamples_{Cr}$.

— Otherwise ($PartMode$ is equal to $PART_NxN$), the following ordered steps apply:

1. The decoding process for prediction units in inter prediction mode as specified in 8.5.3 is invoked with the luma location (xCb, yCb) , the luma location (xBl, yBl) set equal to $(0, 0)$, the size of the luma coding block $nCbS_L$, the width of the luma prediction block $nPbW$ set equal to $nCbS_L \gg 1$, the height of the luma prediction block $nPbH$ set equal to $nCbS_L \gg 1$, and a

partition index partIdx set equal to 0 as inputs, and the outputs are an $(nCbS_L) \times (nCbS_L)$ array predSamples_L and, when ChromaArrayType is not equal to 0, two $(nCbSw_C) \times (nCbSh_C)$ arrays predSamples_{Cb} and predSamples_{Cr} .

2. The decoding process for prediction units in inter prediction mode as specified in 8.5.3 is invoked with the luma location (x_{Cb}, y_{Cb}) , the luma location (x_{Bl}, y_{Bl}) set equal to $(nCbS_L \gg 1, 0)$, the size of the luma coding block $nCbS_L$, the width of the luma prediction block $nPbW$ set equal to $nCbS_L \gg 1$, the height of the luma prediction block $nPbH$ set equal to $nCbS_L \gg 1$, and a partition index partIdx set equal to 1 as inputs, and the outputs are the modified $(nCbS_L) \times (nCbS_L)$ array predSamples_L and, when ChromaArrayType is not equal to 0, the two modified $(nCbSw_C) \times (nCbSh_C)$ arrays predSamples_{Cb} and predSamples_{Cr} .
3. The decoding process for prediction units in inter prediction mode as specified in 8.5.3 is invoked with the luma location (x_{Cb}, y_{Cb}) , the luma location (x_{Bl}, y_{Bl}) set equal to $(0, nCbS_L \gg 1)$, the size of the luma coding block $nCbS_L$, the width of the luma prediction block $nPbW$ set equal to $nCbS_L \gg 1$, the height of the luma prediction block $nPbH$ set equal to $nCbS_L \gg 1$, and a partition index partIdx set equal to 2 as inputs, and the outputs are the modified $(nCbS_L) \times (nCbS_L)$ array predSamples_L and, when ChromaArrayType is not equal to 0, the two modified $(nCbSw_C) \times (nCbSh_C)$ arrays predSamples_{Cb} and predSamples_{Cr} .
4. The decoding process for prediction units in inter prediction mode as specified in 8.5.3 is invoked with the luma location (x_{Cb}, y_{Cb}) , the luma location (x_{Bl}, y_{Bl}) set equal to $(nCbS_L \gg 1, nCbS_L \gg 1)$, the size of the luma coding block $nCbS_L$, the width of the luma prediction block $nPbW$ set equal to $nCbS_L \gg 1$, the height of the luma prediction block $nPbH$ set equal to $nCbS_L \gg 1$, and a partition index partIdx set equal to 3 as inputs, and the outputs are the modified $(nCbS_L) \times (nCbS_L)$ array predSamples_L and, when ChromaArrayType is not equal to 0, the two modified $(nCbSw_C) \times (nCbSh_C)$ arrays predSamples_{Cb} and predSamples_{Cr} .

8.5.3 Decoding process for prediction units in inter prediction mode

8.5.3.1 General

Inputs to this process are

- a luma location (x_{Cb}, y_{Cb}) specifying the top-left sample of the current luma coding block relative to the top-left luma sample of the current picture,
- a luma location (x_{Bl}, y_{Bl}) specifying the top-left sample of the current luma prediction block relative to the top-left sample of the current luma coding block,
- a variable $nCbS$ specifying the size of the current luma coding block,
- a variable $nPbW$ specifying the width of the current luma prediction block,
- a variable $nPbH$ specifying the height of the current luma prediction block, and
- a variable partIdx specifying the index of the current prediction unit within the current coding unit.

Outputs of this process are

- an $(nCbS_L) \times (nCbS_L)$ array predSamples_L of luma prediction samples, where $nCbS_L$ is derived as specified below,
- when ChromaArrayType is not equal to 0, an $(nCbSw_C) \times (nCbSh_C)$ array predSamples_{Cb} of chroma prediction samples for the component Cb, where $nCbSw_C$ and $nCbSh_C$ are derived as specified below,

- when ChromaArrayType is not equal to 0, an $(nCbSw_C) \times (nCbSh_C)$ array $predSamples_{Cr}$ of chroma prediction samples for the component Cr, where $nCbSw_C$ and $nCbSh_C$ are derived as specified below.

The variable $nCbS_L$ is set equal to $nCbS$. When ChromaArrayType is not equal to 0, the variable $nCbSw_C$ is set equal to $nCbS / SubWidthC$ and the variable $nCbSh_C$ is set equal to $nCbS / SubHeightC$.

The decoding process for prediction units in inter prediction mode consists of the following ordered steps:

1. The derivation process for motion vector components and reference indices as specified in 8.5.3.2 is invoked with the luma coding block location (xCb, yCb) , the luma prediction block location (xBl, yBl) , the luma coding block size block $nCbS$, the luma prediction block width $nPbW$, the luma prediction block height $nPbH$, and the prediction unit index $partIdx$ as inputs, and the luma motion vectors $mvL0$ and $mvL1$, when ChromaArrayType is not equal to 0, the chroma motion vectors $mvCL0$ and $mvCL1$, the reference indices $refIdxL0$ and $refIdxL1$, and the prediction list utilization flags $predFlagL0$ and $predFlagL1$ as outputs.
2. The decoding process for inter sample prediction as specified in 8.5.3.3 is invoked with the luma coding block location (xCb, yCb) , the luma prediction block location (xBl, yBl) , the luma coding block size block $nCbS$, the luma prediction block width $nPbW$, the luma prediction block height $nPbH$, the luma motion vectors $mvL0$ and $mvL1$, when ChromaArrayType is not equal to 0, the chroma motion vectors $mvCL0$ and $mvCL1$, the reference indices $refIdxL0$ and $refIdxL1$, and the prediction list utilization flags $predFlagL0$ and $predFlagL1$ as inputs, and the inter prediction samples ($predSamples$) that are an $(nCbS_L) \times (nCbS_L)$ array $predSamples_L$ of prediction luma samples and, when ChromaArrayType is not equal to 0, two $(nCbSw_C) \times (nCbSh_C)$ arrays $predSamples_{Cb}$ and $predSamples_{Cr}$ of prediction chroma samples, one for each of the chroma components Cb and Cr, as outputs.

For use in derivation processes of variables invoked later in the decoding process, the following assignments are made for $x = xBl..xBl + nPbW - 1$ and $y = yBl..yBl + nPbH - 1$:

$$MvL0[xCb + x][yCb + y] = mvL0 \quad (8-80)$$

$$MvL1[xCb + x][yCb + y] = mvL1 \quad (8-81)$$

$$RefIdxL0[xCb + x][yCb + y] = refIdxL0 \quad (8-82)$$

$$RefIdxL1[xCb + x][yCb + y] = refIdxL1 \quad (8-83)$$

$$PredFlagL0[xCb + x][yCb + y] = predFlagL0 \quad (8-84)$$

$$PredFlagL1[xCb + x][yCb + y] = predFlagL1 \quad (8-85)$$

8.5.3.2 Derivation process for motion vector components and reference indices

8.5.3.2.1 General

Inputs to this process are

- a luma location (xCb, yCb) of the top-left sample of the current luma coding block relative to the top-left luma sample of the current picture,
- a luma location (xBl, yBl) of the top-left sample of the current luma prediction block relative to the top-left sample of the current luma coding block,
- a variable $nCbS$ specifying the size of the current luma coding block,

ISO/IEC 23008-2:2017(E)

- two variables $nPbW$ and $nPbH$ specifying the width and the height of the luma prediction block, and
- a variable $partIdx$ specifying the index of the current prediction unit within the current coding unit.

Outputs of this process are

- the luma motion vectors $mvL0$ and $mvL1$,
- when $ChromaArrayType$ is not equal to 0, the chroma motion vectors $mvCL0$ and $mvCL1$,
- the reference indices $refIdxL0$ and $refIdxL1$, and
- the prediction list utilization flags $predFlagL0$ and $predFlagL1$.

Let (xPb, yPb) specify the top-left sample location of the current luma prediction block relative to the top-left luma sample of the current picture where $xPb = xCb + xBl$ and $yPb = yCb + yBl$.

Let the variable LX be $RefPicListX$, with X being 0 or 1, of the current picture.

The variables $nPbSw$, and $nPbSh$ are derived as follows:

$$nPbSw = nCbS / ((PartMode == PART_2Nx2N || PartMode == PART_2NxN) ? 1 : 2) \quad (8-86)$$

$$nPbSh = nCbS / ((PartMode == PART_2Nx2N || PartMode == PART_Nx2N) ? 1 : 2) \quad (8-87)$$

The function $LongTermRefPic(aPic, aPb, refIdx, LX)$, with X being 0 or 1, is defined as follows:

- If the picture with index $refIdx$ from reference picture list LX of the slice containing prediction block aPb in the picture $aPic$ was marked as "used for long-term reference" at the time when $aPic$ was the current picture, $LongTermRefPic(aPic, aPb, refIdx, LX)$ is equal to 1.
- Otherwise, $LongTermRefPic(aPic, aPb, refIdx, LX)$ is equal to 0.

For the derivation of the variables $mvL0$ and $mvL1$, $refIdxL0$ and $refIdxL1$, as well as $predFlagL0$ and $predFlagL1$, the following apply:

- If $merge_flag[xPb][yPb]$ is equal to 1, the derivation process for luma motion vectors for merge mode as specified in 8.5.3.2.2 is invoked with the luma location (xCb, yCb) , the luma location (xPb, yPb) , the variables $nCbS$, $nPbW$, $nPbH$, and the partition index $partIdx$ as inputs, and the output being the luma motion vectors $mvL0$, $mvL1$, the reference indices $refIdxL0$, $refIdxL1$, and the prediction list utilization flags $predFlagL0$ and $predFlagL1$.
- Otherwise, for X being replaced by either 0 or 1 in the variables $predFlagLX$, $mvLX$, and $refIdxLX$, in $PRED_LX$, and in the syntax elements ref_idx_IX and $MvdLX$, the following ordered steps apply:

1. The variables $refIdxLX$ and $predFlagLX$ are derived as follows:

- If $inter_pred_idc[xPb][yPb]$ is equal to $PRED_LX$ or $PRED_BI$,

$$refIdxLX = ref_idx_IX[xPb][yPb] \quad (8-88)$$

$$predFlagLX = 1 \quad (8-89)$$

- Otherwise, the variables $refIdxLX$ and $predFlagLX$ are specified by:

$$refIdxLX = -1 \quad (8-90)$$

$$predFlagLX = 0 \quad (8-91)$$

2. The variable `mvdLX` is derived as follows:

$$\text{mvdLX}[0] = \text{MvdLX}[\text{xPb}][\text{yPb}][0] \quad (8-92)$$

$$\text{mvdLX}[1] = \text{MvdLX}[\text{xPb}][\text{yPb}][1] \quad (8-93)$$

3. When `predFlagLX` is equal to 1, the derivation process for luma motion vector prediction in 8.5.3.2.6 is invoked with the luma coding block location (`xCb`, `yCb`), the coding block size `nCbS`, the luma prediction block location (`xPb`, `yPb`), the variables `nPbW`, `nPbH`, `refIdxLX`, and the partition index `partIdx` as inputs, and the output being `mvpLX`.

4. When `predFlagLX` is equal to 1 and the picture with index `refIdx` from reference picture list `LX` of the slice is not the current picture, and `use_integer_mv_flag` is equal to 0, the luma motion vector `mvLX` is derived as follows:

$$\text{uLX}[0] = (\text{mvpLX}[0] + \text{mvdLX}[0] + 2^{16}) \% 2^{16} \quad (8-94)$$

$$\text{mvLX}[0] = (\text{uLX}[0] \geq 2^{15}) ? (\text{uLX}[0] - 2^{16}) : \text{uLX}[0] \quad (8-95)$$

$$\text{uLX}[1] = (\text{mvpLX}[1] + \text{mvdLX}[1] + 2^{16}) \% 2^{16} \quad (8-96)$$

$$\text{mvLX}[1] = (\text{uLX}[1] \geq 2^{15}) ? (\text{uLX}[1] - 2^{16}) : \text{uLX}[1] \quad (8-97)$$

NOTE 1 The resulting values of `mvLX[0]` and `mvLX[1]` as specified above will always be in the range of -2^{15} to $2^{15} - 1$, inclusive.

5. When `predFlagLX` is equal to 1 and the reference picture is the current picture, or when `predFlagLX` is equal to 1 and `use_integer_mv_flag` is equal to 1, the luma motion vector `mvLX` is derived as follows:

$$\text{uLX}[0] = (((\text{mvpLX}[0] \gg 2) + \text{mvdLX}[0]) \ll 2) + 2^{16}) \% 2^{16} \quad (8-98)$$

$$\text{mvLX}[0] = (\text{uLX}[0] \geq 2^{15}) ? (\text{uLX}[0] - 2^{16}) : \text{uLX}[0] \quad (8-99)$$

$$\text{uLX}[1] = (((\text{mvpLX}[1] \gg 2) + \text{mvdLX}[1]) \ll 2) + 2^{16}) \% 2^{16} \quad (8-100)$$

$$\text{mvLX}[1] = (\text{uLX}[1] \geq 2^{15}) ? (\text{uLX}[1] - 2^{16}) : \text{uLX}[1] \quad (8-101)$$

NOTE 2 The resulting values of `mvLX[0]` and `mvLX[1]` as specified above will always be in the range of -2^{15} to $2^{15} - 1$, inclusive.

— The variable `noIntegerMvFlag` is derived as follows:

$$\text{noIntegerMvFlag} = !((\text{mvL0} \& 0x3 == 0) \mid (\text{mvL1} \& 0x3 == 0)) \quad (8-102)$$

— The variable `identicalMvs` is derived as follows:

$$\text{identicalMvs} = (\text{mvL0} == \text{mvL1}) \&\& (\text{DiffPicOrderCnt}(\text{RefPicList0}[\text{refIdxL0}], \text{RefPicList1}[\text{refIdxL1}]) == 0) \quad (8-103)$$

When all of the following conditions are true, `refIdxL1` is set equal to -1 and `predFlagL1` is set equal to 0.

- `predFlagL0` is equal to 1.
- `predFlagL1` is equal to 1.
- `nPbSw` is equal to 8.

ISO/IEC 23008-2:2017(E)

- nPbSh is equal to 8.
- TwoVersionsOfCurrDecPicFlag is equal to 1.
- noIntegerMvFlag is equal to 1.
- identicalMvs is equal to 0.

When ChromaArrayType is not equal to 0 and predFlagLX, with X being 0 or 1, is equal to 1, the derivation process for chroma motion vectors in 8.5.3.2.10 is invoked with mvLX as input, and the output being mvCLX.

The variables offsetX and offsetY are derived as follows:

$$\text{offsetX} = (\text{ChromaArrayType} = 0) ? 0 : (\text{mvCLX}[0] \& 0x7 ? 2 : 0) \quad (8-104)$$

$$\text{offsetY} = (\text{ChromaArrayType} = 0) ? 0 : (\text{mvCLX}[1] \& 0x7 ? 2 : 0) \quad (8-105)$$

It is a requirement of bitstream conformance that when the reference picture is the current picture, the luma motion vector mvLX shall obey the following constraints:

- When the derivation process for z-scan order block availability as specified in 6.4.1 is invoked with (xCurr, yCurr) set equal to (xCb, yCb) and the neighbouring luma location (xNbY, yNbY) set equal to (xPb + (mvLX[0] >> 2) - offsetX, yPb + (mvLX[1] >> 2) - offsetY) as inputs, the output shall be equal to TRUE.
- When the derivation process for z-scan order block availability as specified in 6.4.1 is invoked with (xCurr, yCurr) set equal to (xCb, yCb) and the neighbouring luma location (xNbY, yNbY) set equal to (xPb + (mvLX[0] >> 2) + nPbW - 1 + offsetX, yPb + (mvLX[1] >> 2) + nPbH - 1 + offsetY) as inputs, the output shall be equal to TRUE.
- One or both of the following conditions shall be true:
 - The value of (mvLX[0] >> 2) + nPbW + xB1 + offsetX is less than or equal to 0.
 - The value of (mvLX[1] >> 2) + nPbH + yB1 + offsetY is less than or equal to 0.
- The following condition shall be true:

$$\frac{(xPb + (mvLX[0] \gg 2) + nPbSw - 1 + offsetX) / CtbSizeY - xCb / CtbSizeY}{yCb / CtbSizeY - (yPb + (mvLX[1] \gg 2) + nPbSh - 1 + offsetY) / CtbSizeY} \leq 0 \quad (8-106)$$

8.5.3.2.2 Derivation process for luma motion vectors for merge mode

This process is only invoked when merge_flag[xPb][yPb] is equal to 1, where (xPb, yPb) specify the top-left sample of the current luma prediction block relative to the top-left luma sample of the current picture.

Inputs to this process are

- a luma location (xCb, yCb) of the top-left sample of the current luma coding block relative to the top-left luma sample of the current picture,
- a luma location (xPb, yPb) of the top-left sample of the current luma prediction block relative to the top-left luma sample of the current picture,
- a variable nCbS specifying the size of the current luma coding block,

- two variables nPbW and nPbH specifying the width and the height of the luma prediction block, and
- a variable partIdx specifying the index of the current prediction unit within the current coding unit.

Outputs of this process are

- the luma motion vectors mvL0 and mvL1,
- the reference indices refIdxL0 and refIdxL1, and
- the prediction list utilization flags predFlagL0 and predFlagL1.

The location (xOrigP, yOrigP) and the variables nOrigPbW and nOrigPbH are derived to store the values of (xPb, yPb), nPbW, and nPbH as follows:

$$(xOrigP, yOrigP) \text{ is set equal to } (xPb, yPb) \quad (8-107)$$

$$nOrigPbW = nPbW \quad (8-108)$$

$$nOrigPbH = nPbH \quad (8-109)$$

When Log2ParMrgLevel is greater than 2 and nCbS is equal to 8, (xPb, yPb), nPbW, nPbH, and partIdx are modified as follows:

$$(xPb, yPb) = (xCb, yCb) \quad (8-110)$$

$$nPbW = nCbS \quad (8-111)$$

$$nPbH = nCbS \quad (8-112)$$

$$partIdx = 0 \quad (8-113)$$

NOTE When Log2ParMrgLevel is greater than 2 and nCbS is equal to 8, all the prediction units of the current coding unit share a single merge candidate list, which is identical to the merge candidate list of the 2Nx2N prediction unit.

The motion vectors mvL0 and mvL1, the reference indices refIdxL0 and refIdxL1, and the prediction utilization flags predFlagL0 and predFlagL1 are derived by the following ordered steps:

1. The derivation process for merging candidates from neighbouring prediction unit partitions in 8.5.3.2.3 is invoked with the luma coding block location (xCb, yCb), the coding block size nCbS, the luma prediction block location (xPb, yPb), the luma prediction block width nPbW, the luma prediction block height nPbH, and the partition index partIdx as inputs, and the output being the availability flags availableFlagA₀, availableFlagA₁, availableFlagB₀, availableFlagB₁, and availableFlagB₂, the reference indices refIdxLXA₀, refIdxLXA₁, refIdxLXB₀, refIdxLXB₁, and refIdxLXB₂, the prediction list utilization flags predFlagLXA₀, predFlagLXA₁, predFlagLXB₀, predFlagLXB₁, and predFlagLXB₂, and the motion vectors mvLXA₀, mvLXA₁, mvLXB₀, mvLXB₁, and mvLXB₂, with X being 0 or 1.
2. The reference indices for the temporal merging candidate, refIdxLXCol, with X being 0 or 1, are set equal to 0.
3. The derivation process for temporal luma motion vector prediction in 8.5.3.2.8 is invoked with the luma location (xPb, yPb), the luma prediction block width nPbW, the luma prediction block height nPbH, and the variable refIdxL0Col as inputs, and the output being the availability flag availableFlagL0Col and the temporal motion vector mvL0Col. The variables availableFlagCol, predFlagL0Col and predFlagL1Col are derived as follows:

$$\text{availableFlagCol} = \text{availableFlagL0Col} \quad (8-114)$$

$$\text{predFlagL0Col} = \text{availableFlagL0Col} \quad (8-115)$$

$$\text{predFlagL1Col} = 0 \quad (8-116)$$

4. When `slice_type` is equal to B, the derivation process for temporal luma motion vector prediction in 8.5.3.2.8 is invoked with the luma location (`xPb`, `yPb`), the luma prediction block width `nPbW`, the luma prediction block height `nPbH`, and the variable `refIdxL1Col` as inputs, and the output being the availability flag `availableFlagL1Col` and the temporal motion vector `mvL1Col`. The variables `availableFlagCol` and `predFlagL1Col` are derived as follows:

$$\text{availableFlagCol} = \text{availableFlagL0Col} \mid \mid \text{availableFlagL1Col} \quad (8-117)$$

$$\text{predFlagL1Col} = \text{availableFlagL1Col} \quad (8-118)$$

5. The merging candidate list, `mergeCandList`, is constructed as follows:

```

i = 0
if( availableFlagA1 )
    mergeCandList[ i++ ] = A1
if( availableFlagB1 )
    mergeCandList[ i++ ] = B1
if( availableFlagB0 )
    mergeCandList[ i++ ] = B0
if( availableFlagA0 )
    mergeCandList[ i++ ] = A0
if( availableFlagB2 )
    mergeCandList[ i++ ] = B2
if( availableFlagCol )
    mergeCandList[ i++ ] = Col
    
```

(8-119)

6. The variable `numCurrMergeCand` and `numOrigMergeCand` are set equal to the number of merging candidates in the `mergeCandList`.

7. When `slice_type` is equal to B, the derivation process for combined bi-predictive merging candidates specified in 8.5.3.2.4 is invoked with `mergeCandList`, the reference indices `refIdxL0N` and `refIdxL1N`, the prediction list utilization flags `predFlagL0N` and `predFlagL1N`, the motion vectors `mvL0N` and `mvL1N` of every candidate N in `mergeCandList`, `numCurrMergeCand`, and `numOrigMergeCand` as inputs, and the output is assigned to `mergeCandList`, `numCurrMergeCand`, the reference indices `refIdxL0combCandk` and `refIdxL1combCandk`, the prediction list utilization flags `predFlagL0combCandk` and `predFlagL1combCandk`, and the motion vectors `mvL0combCandk` and `mvL1combCandk` of every new candidate `combCandk` being added into `mergeCandList`. The number of candidates being added, `numCombMergeCand`, is set equal to (`numCurrMergeCand` - `numOrigMergeCand`). When `numCombMergeCand` is greater than 0, `k` ranges from 0 to `numCombMergeCand` - 1, inclusive.

8. The derivation process for zero motion vector merging candidates specified in 8.5.3.2.5 is invoked with the `mergeCandList`, the reference indices `refIdxL0N` and `refIdxL1N`, the prediction list utilization flags `predFlagL0N` and `predFlagL1N`, the motion vectors `mvL0N` and `mvL1N` of every candidate N in `mergeCandList`, and `numCurrMergeCand` as inputs, and the output is assigned to `mergeCandList`, `numCurrMergeCand`, the reference indices `refIdxL0zeroCandm` and `refIdxL1zeroCandm`, the prediction list utilization flags `predFlagL0zeroCandm` and `predFlagL1zeroCandm`, and the motion vectors `mvL0zeroCandm` and `mvL1zeroCandm` of every new candidate `zeroCandm` being added into `mergeCandList`. The number of candidates being added, `numZeroMergeCand`, is set equal to

(numCurrMergeCand – numOrigMergeCand – numCombMergeCand). When numZeroMergeCand is greater than 0, m ranges from 0 to numZeroMergeCand – 1, inclusive.

9. The following assignments are made with N being the candidate at position merge_idx[xOrigP][yOrigP] in the merging candidate list mergeCandList (N = mergeCandList[merge_idx[xOrigP][yOrigP]]) and X being replaced by 0 or 1:

$$\text{refIdxLX} = \text{refIdxLXN} \quad (8-120)$$

$$\text{predFlagLX} = \text{predFlagLXN} \quad (8-121)$$

1. When use_integer_mv_flag is equal to 0 and the reference picture is not the current picture, the following apply:

$$\text{mvLX}[0] = \text{mvLXN}[0] \quad (8-122)$$

$$\text{mvLX}[1] = \text{mvLXN}[1] \quad (8-123)$$

2. Otherwise (use_integer_mv_flag is equal to 1 or the reference picture is the current picture), the following apply:

$$\text{mvLX}[0] = (\text{mvLXN}[0] \gg 2) \ll 2 \quad (8-124)$$

$$\text{mvLX}[1] = (\text{mvLXN}[1] \gg 2) \ll 2 \quad (8-125)$$

10. When predFlagL0 is equal to 1 and predFlagL1 is equal to 1, and (nOrigPbW + nOrigPbH) is equal to 12, the following apply:

$$\text{refIdxL1} = -1 \quad (8-126)$$

$$\text{predFlagL1} = 0 \quad (8-127)$$

8.5.3.2.3 Derivation process for spatial merging candidates

Inputs to this process are

- a luma location (xCb, yCb) of the top-left sample of the current luma coding block relative to the top-left luma sample of the current picture,
- a variable nCbS specifying the size of the current luma coding block,
- a luma location (xPb, yPb) specifying the top-left sample of the current luma prediction block relative to the top-left luma sample of the current picture,
- two variables nPbW and nPbH specifying the width and the height of the luma prediction block, and
- a variable partIdx specifying the index of the current prediction unit within the current coding unit.

Outputs of this process are as follows, with X being 0 or 1

- the availability flags availableFlagA₀, availableFlagA₁, availableFlagB₀, availableFlagB₁, and availableFlagB₂ of the neighbouring prediction units,
- the reference indices refIdxLXA₀, refIdxLXA₁, refIdxLXB₀, refIdxLXB₁, and refIdxLXB₂ of the neighbouring prediction units,

ISO/IEC 23008-2:2017(E)

- the prediction list utilization flags predFlagLXA_0 , predFlagLXA_1 , predFlagLXB_0 , predFlagLXB_1 , and predFlagLXB_2 of the neighbouring prediction units, and
- the motion vectors mvLXA_0 , mvLXA_1 , mvLXB_0 , mvLXB_1 , and mvLXB_2 of the neighbouring prediction units.

For the derivation of availableFlagA_1 , refIdxLXA_1 , predFlagLXA_1 , and mvLXA_1 the following apply:

- The luma location $(x_{\text{NbA}_1}, y_{\text{NbA}_1})$ inside the neighbouring luma coding block is set equal to $(x_{\text{Pb}} - 1, y_{\text{Pb}} + n_{\text{PbH}} - 1)$.
- The availability derivation process for a prediction block as specified in 6.4.2 is invoked with the luma location $(x_{\text{Cb}}, y_{\text{Cb}})$, the current luma coding block size n_{CbS} , the luma prediction block location $(x_{\text{Pb}}, y_{\text{Pb}})$, the luma prediction block width n_{PbW} , the luma prediction block height n_{PbH} , the luma location $(x_{\text{NbA}_1}, y_{\text{NbA}_1})$, and the partition index partIdx as inputs, and the output is assigned to the prediction block availability flag availableA_1 .
- When one or more of the following conditions are true, availableA_1 is set equal to FALSE:
 - $x_{\text{Pb}} \gg \text{Log2ParMrgLevel}$ is equal to $x_{\text{NbA}_1} \gg \text{Log2ParMrgLevel}$ and $y_{\text{Pb}} \gg \text{Log2ParMrgLevel}$ is equal to $y_{\text{NbA}_1} \gg \text{Log2ParMrgLevel}$.
 - PartMode of the current prediction unit is equal to $\text{PART}_{\text{Nx}2\text{N}}$, $\text{PART}_{\text{nLx}2\text{N}}$, or $\text{PART}_{\text{nRx}2\text{N}}$, and partIdx is equal to 1.
- The variables availableFlagA_1 , refIdxLXA_1 , predFlagLXA_1 , and mvLXA_1 are derived as follows:
 - If availableA_1 is equal to FALSE, availableFlagA_1 is set equal to 0, both components of mvLXA_1 are set equal to 0, refIdxLXA_1 is set equal to -1 and predFlagLXA_1 is set equal to 0, with X being 0 or 1.
 - Otherwise, availableFlagA_1 is set equal to 1 and the following assignments are made:

$$\text{mvLXA}_1 = \text{MvLX}[x_{\text{NbA}_1}][y_{\text{NbA}_1}] \quad (8-128)$$

$$\text{refIdxLXA}_1 = \text{RefIdxLX}[x_{\text{NbA}_1}][y_{\text{NbA}_1}] \quad (8-129)$$

$$\text{predFlagLXA}_1 = \text{PredFlagLX}[x_{\text{NbA}_1}][y_{\text{NbA}_1}] \quad (8-130)$$

For the derivation of availableFlagB_1 , refIdxLXB_1 , predFlagLXB_1 , and mvLXB_1 the following apply:

- The luma location $(x_{\text{NbB}_1}, y_{\text{NbB}_1})$ inside the neighbouring luma coding block is set equal to $(x_{\text{Pb}} + n_{\text{PbW}} - 1, y_{\text{Pb}} - 1)$.
- The availability derivation process for a prediction block as specified in 6.4.2 is invoked with the luma location $(x_{\text{Cb}}, y_{\text{Cb}})$, the current luma coding block size n_{CbS} , the luma prediction block location $(x_{\text{Pb}}, y_{\text{Pb}})$, the luma prediction block width n_{PbW} , the luma prediction block height n_{PbH} , the luma location $(x_{\text{NbB}_1}, y_{\text{NbB}_1})$, and the partition index partIdx as inputs, and the output is assigned to the prediction block availability flag availableB_1 .
- When one or more of the following conditions are true, availableB_1 is set equal to FALSE:
 - $x_{\text{Pb}} \gg \text{Log2ParMrgLevel}$ is equal to $x_{\text{NbB}_1} \gg \text{Log2ParMrgLevel}$ and $y_{\text{Pb}} \gg \text{Log2ParMrgLevel}$ is equal to $y_{\text{NbB}_1} \gg \text{Log2ParMrgLevel}$.
 - PartMode of the current prediction unit is equal to $\text{PART}_{2\text{NxN}}$, $\text{PART}_{2\text{NxN}U}$, or $\text{PART}_{2\text{NxN}D}$, and partIdx is equal to 1.

- The variables availableFlagB_1 , refIdxLXB_1 , predFlagLXB_1 , and mvLXB_1 are derived as follows:
 - If one or more of the following conditions are true, availableFlagB_1 is set equal to 0, both components of mvLXB_1 are set equal to 0, refIdxLXB_1 is set equal to -1 , and predFlagLXB_1 is set equal to 0, with X being 0 or 1:
 1. availableB_1 is equal to FALSE.
 2. availableA_1 is equal to TRUE and the prediction units covering the luma locations $(xNbA_1, yNbA_1)$ and $(xNbB_1, yNbB_1)$ have the same motion vectors and the same reference indices.
 - Otherwise, availableFlagB_1 is set equal to 1 and the following assignments are made:

$$\text{mvLXB}_1 = \text{MvLX}[xNbB_1][yNbB_1] \quad (8-131)$$

$$\text{refIdxLXB}_1 = \text{RefIdxLX}[xNbB_1][yNbB_1] \quad (8-132)$$

$$\text{predFlagLXB}_1 = \text{PredFlagLX}[xNbB_1][yNbB_1] \quad (8-133)$$

For the derivation of availableFlagB_0 , refIdxLXB_0 , predFlagLXB_0 , and mvLXB_0 the following apply:

- The luma location $(xNbB_0, yNbB_0)$ inside the neighbouring luma coding block is set equal to $(xPb + nPbW, yPb - 1)$.
- The availability derivation process for a prediction block as specified in 6.4.2 is invoked with the luma location (xCb, yCb) , the current luma coding block size $nCbS$, the luma prediction block location (xPb, yPb) , the luma prediction block width $nPbW$, the luma prediction block height $nPbH$, the luma location $(xNbB_0, yNbB_0)$, and the partition index partIdx as inputs, and the output is assigned to the prediction block availability flag availableB_0 .
- When $xPb \gg \text{Log2ParMrgLevel}$ is equal to $xNbB_0 \gg \text{Log2ParMrgLevel}$ and $yPb \gg \text{Log2ParMrgLevel}$ is equal to $yNbB_0 \gg \text{Log2ParMrgLevel}$, availableB_0 is set equal to FALSE.
- The variables availableFlagB_0 , refIdxLXB_0 , predFlagLXB_0 , and mvLXB_0 are derived as follows:
 - If one or more of the following conditions are true, availableFlagB_0 is set equal to 0, both components of mvLXB_0 are set equal to 0, refIdxLXB_0 is set equal to -1 , and predFlagLXB_0 is set equal to 0, with X being 0 or 1:
 1. availableB_0 is equal to FALSE.
 2. availableB_1 is equal to TRUE and the prediction units covering the luma locations $(xNbB_1, yNbB_1)$ and $(xNbB_0, yNbB_0)$ have the same motion vectors and the same reference indices.
 - Otherwise, availableFlagB_0 is set equal to 1 and the following assignments are made:

$$\text{mvLXB}_0 = \text{MvLX}[xNbB_0][yNbB_0] \quad (8-134)$$

$$\text{refIdxLXB}_0 = \text{RefIdxLX}[xNbB_0][yNbB_0] \quad (8-135)$$

$$\text{predFlagLXB}_0 = \text{PredFlagLX}[xNbB_0][yNbB_0] \quad (8-136)$$

For the derivation of availableFlagA_0 , refIdxLXA_0 , predFlagLXA_0 , and mvLXA_0 the following apply:

- The luma location $(xNbA_0, yNbA_0)$ inside the neighbouring luma coding block is set equal to $(xPb - 1, yPb + nPbH)$.

ISO/IEC 23008-2:2017(E)

- The availability derivation process for a prediction block as specified in 6.4.2 is invoked with the luma location (x_{Cb}, y_{Cb}), the current luma coding block size n_{CbS} , the luma prediction block location (x_{Pb}, y_{Pb}), the luma prediction block width n_{PbW} , the luma prediction block height n_{PbH} , the luma location (x_{NbA_0}, y_{NbA_0}), and the partition index $partIdx$ as inputs, and the output is assigned to the prediction block availability flag $availableA_0$.
- When $x_{Pb} \gg \text{Log2ParMrgLevel}$ is equal to $x_{NbA_0} \gg \text{Log2ParMrgLevel}$ and $y_{Pb} \gg \text{Log2ParMrgLevel}$ is equal to $y_{A_0} \gg \text{Log2ParMrgLevel}$, $availableA_0$ is set equal to FALSE.
- The variables $availableFlagA_0$, $refIdxLXA_0$, $predFlagLXA_0$, and $mvLXA_0$ are derived as follows:
 - If one or more of the following conditions are true, $availableFlagA_0$ is set equal to 0, both components of $mvLXA_0$ are set equal to 0, $refIdxLXA_0$ is set equal to -1, and $predFlagLXA_0$ is set equal to 0, with X being 0 or 1:
 1. $availableA_0$ is equal to FALSE.
 2. $availableA_1$ is equal to TRUE and the prediction units covering the luma locations (x_{NbA_1}, y_{NbA_1}) and (x_{NbA_0}, y_{NbA_0}) have the same motion vectors and the same reference indices.
 - Otherwise, $availableFlagA_0$ is set equal to 1 and the following assignments are made:

$$mvLXA_0 = MvLX[x_{NbA_0}][y_{NbA_0}] \quad (8-137)$$

$$refIdxLXA_0 = RefIdxLX[x_{NbA_0}][y_{NbA_0}] \quad (8-138)$$

$$predFlagLXA_0 = PredFlagLX[x_{NbA_0}][y_{NbA_0}] \quad (8-139)$$

For the derivation of $availableFlagB_2$, $refIdxLXB_2$, $predFlagLXB_2$, and $mvLXB_2$ the following apply:

- The luma location (x_{NbB_2}, y_{NbB_2}) inside the neighbouring luma coding block is set equal to ($x_{Pb} - 1, y_{Pb} - 1$).
- The availability derivation process for a prediction block as specified in 6.4.2 is invoked with the luma location (x_{Cb}, y_{Cb}), the current luma coding block size n_{CbS} , the luma prediction block location (x_{Pb}, y_{Pb}), the luma prediction block width n_{PbW} , the luma prediction block height n_{PbH} , the luma location (x_{NbB_2}, y_{NbB_2}), and the partition index $partIdx$ as inputs, and the output is assigned to the prediction block availability flag $availableB_2$.
- When $x_{Pb} \gg \text{Log2ParMrgLevel}$ is equal to $x_{NbB_2} \gg \text{Log2ParMrgLevel}$ and $y_{Pb} \gg \text{Log2ParMrgLevel}$ is equal to $y_{NbB_2} \gg \text{Log2ParMrgLevel}$, $availableB_2$ is set equal to FALSE.
- The variables $availableFlagB_2$, $refIdxLXB_2$, $predFlagLXB_2$, and $mvLXB_2$ are derived as follows:
 - If one or more of the following conditions are true, $availableFlagB_2$ is set equal to 0, both components of $mvLXB_2$ are set equal to 0, $refIdxLXB_2$ is set equal to -1, and $predFlagLXB_2$ is set equal to 0, with X being 0 or 1:
 1. $availableB_2$ is equal to FALSE.
 2. $availableA_1$ is equal to TRUE and prediction units covering the luma locations (x_{NbA_1}, y_{NbA_1}) and (x_{NbB_2}, y_{NbB_2}) have the same motion vectors and the same reference indices.

3. availableB₁ is equal to TRUE and the prediction units covering the luma locations (xNbB₁, yNbB₁) and (xNbB₂, yNbB₂) have the same motion vectors and the same reference indices.
 4. availableFlagA₀ + availableFlagA₁ + availableFlagB₀ + availableFlagB₁ is equal to 4.
- Otherwise, availableFlagB₂ is set equal to 1, and the following assignments are made:
- $$mvLXB_2 = MvLX[xNbB_2][yNbB_2] \quad (8-140)$$
- $$refIdxLXB_2 = RefIdxLX[xNbB_2][yNbB_2] \quad (8-141)$$
- $$predFlagLXB_2 = PredFlagLX[xNbB_2][yNbB_2] \quad (8-142)$$

8.5.3.2.4 Derivation process for combined bi-predictive merging candidates

Inputs to this process are

- a merging candidate list mergeCandList,
- the reference indices refIdxL0N and refIdxL1N of every candidate N in mergeCandList,
- the prediction list utilization flags predFlagL0N and predFlagL1N of every candidate N in mergeCandList,
- the motion vectors mvL0N and mvL1N of every candidate N in mergeCandList, and
- the number of elements numCurrMergeCand within mergeCandList,
- the number of elements numOrigMergeCand within the mergeCandList after the spatial and temporal merge candidate derivation process.

Outputs of this process are

- the merging candidate list mergeCandList,
- the number of elements numCurrMergeCand within mergeCandList,
- the reference indices refIdxL0combCand_k and refIdxL1combCand_k of every new candidate combCand_k added into mergeCandList during the invocation of this process,
- the prediction list utilization flags predFlagL0combCand_k and predFlagL1combCand_k of every new candidate combCand_k added into mergeCandList during the invocation of this process, and
- the motion vectors mvL0combCand_k and mvL1combCand_k of every new candidate combCand_k added into mergeCandList during the invocation of this process.

When numOrigMergeCand is greater than 1 and less than MaxNumMergeCand, the variable numInputMergeCand is set equal to numCurrMergeCand, the variable combIdx is set equal to 0, the variable combStop is set equal to FALSE, and the following ordered steps are repeated until combStop is equal to TRUE:

1. The variables l0CandIdx and l1CandIdx are derived using combIdx as specified in Table 8-7.
2. The following assignments are made, with l0Cand being the candidate at position l0CandIdx and l1Cand being the candidate at position l1CandIdx in the merging candidate list mergeCandList:
 - l0Cand = mergeCandList[l0CandIdx];

ISO/IEC 23008-2:2017(E)

— $l1Cand = mergeCandList[l1CandIdx]$.

3. When all of the following conditions are true:

— $predFlagL0l0Cand = 1$;

— $predFlagL1l1Cand = 1$;

— $(DiffPicOrderCnt(RefPicList0[refIdxL0l0Cand], RefPicList1[refIdxL1l1Cand]) \neq 0) \ ||$
 $(mvL0l0Cand \neq mvL1l1Cand)$.

the candidate $combCand_k$ with k equal to $(numCurrMergeCand - numInputMergeCand)$ is added at the end of $mergeCandList$, i.e. $mergeCandList[numCurrMergeCand]$ is set equal to $combCand_k$, and the reference indices, the prediction list utilization flags, and the motion vectors of $combCand_k$ are derived as follows and $numCurrMergeCand$ is incremented by 1:

$$refIdxL0combCand_k = refIdxL0l0Cand \tag{8-143}$$

$$refIdxL1combCand_k = refIdxL1l1Cand \tag{8-144}$$

$$predFlagL0combCand_k = 1 \tag{8-145}$$

$$predFlagL1combCand_k = 1 \tag{8-146}$$

$$mvL0combCand_k[0] = mvL0l0Cand[0] \tag{8-147}$$

$$mvL0combCand_k[1] = mvL0l0Cand[1] \tag{8-148}$$

$$mvL1combCand_k[0] = mvL1l1Cand[0] \tag{8-149}$$

$$mvL1combCand_k[1] = mvL1l1Cand[1] \tag{8-150}$$

$$numCurrMergeCand = numCurrMergeCand + 1 \tag{8-151}$$

4. The variable $combIdx$ is incremented by 1.

5. When $combIdx$ is equal to $(numOrigMergeCand * (numOrigMergeCand - 1))$ or $numCurrMergeCand$ is equal to $MaxNumMergeCand$, $combStop$ is set equal to TRUE.

Table 8-7 — Specification of l0CandIdx and l1CandIdx

combIdx	0	1	2	3	4	5	6	7	8	9	10	11
l0CandIdx	0	1	0	2	1	2	0	3	1	3	2	3
l1CandIdx	1	0	2	0	2	1	3	0	3	1	3	2

8.5.3.2.5 Derivation process for zero motion vector merging candidates

Inputs to this process are

— a merging candidate list $mergeCandList$,

— the reference indices $refIdxL0N$ and $refIdxL1N$ of every candidate N in $mergeCandList$,

— the prediction list utilization flags $predFlagL0N$ and $predFlagL1N$ of every candidate N in $mergeCandList$,

— the motion vectors $mvL0N$ and $mvL1N$ of every candidate N in $mergeCandList$, and

- the number of elements numCurrMergeCand within mergeCandList.

Outputs of this process are

- the merging candidate list mergeCandList,
- the number of elements numCurrMergeCand within mergeCandList,
- the reference indices refIdxL0zeroCand_m and refIdxL1zeroCand_m of every new candidate zeroCand_m added into mergeCandList during the invocation of this process,
- the prediction list utilization flags predFlagL0zeroCand_m and predFlagL1zeroCand_m of every new candidate zeroCand_m added into mergeCandList during the invocation of this process, and
- the motion vectors mvL0zeroCand_m and mvL1zeroCand_m of every new candidate zeroCand_m added into mergeCandList during the invocation of this process.

The variable numRefIdx is derived as follows:

- If slice_type is equal to P, numRefIdx is set equal to num_ref_idx_l0_active_minus1 + 1.
- Otherwise (slice_type is equal to B), numRefIdx is set equal to Min(num_ref_idx_l0_active_minus1 + 1, num_ref_idx_l1_active_minus1 + 1).

When numCurrMergeCand is less than MaxNumMergeCand, the variable numInputMergeCand is set equal to numCurrMergeCand, the variable zeroIdx is set equal to 0, and the following ordered steps are repeated until numCurrMergeCand is equal to MaxNumMergeCand:

1. For the derivation of the reference indices, the prediction list utilization flags and the motion vectors of the zero motion vector merging candidate, the following apply:
 - If slice_type is equal to P, the candidate zeroCand_m with m equal to (numCurrMergeCand - numInputMergeCand) is added at the end of mergeCandList, i.e. mergeCandList[numCurrMergeCand] is set equal to zeroCand_m, and the reference indices, the prediction list utilization flags, and the motion vectors of zeroCand_m are derived as follows and numCurrMergeCand is incremented by 1:

$$\text{refIdxL0zeroCand}_m = \{ \text{zeroIdx} < \text{numRefIdx} \} ? \text{zeroIdx} : 0 \quad (8-152)$$

$$\text{refIdxL1zeroCand}_m = -1 \quad (8-153)$$

$$\text{predFlagL0zeroCand}_m = 1 \quad (8-154)$$

$$\text{predFlagL1zeroCand}_m = 0 \quad (8-155)$$

$$\text{mvL0zeroCand}_m[0] = 0 \quad (8-156)$$

$$\text{mvL0zeroCand}_m[1] = 0 \quad (8-157)$$

$$\text{mvL1zeroCand}_m[0] = 0 \quad (8-158)$$

$$\text{mvL1zeroCand}_m[1] = 0 \quad (8-159)$$

$$\text{numCurrMergeCand} = \text{numCurrMergeCand} + 1 \quad (8-160)$$

- Otherwise (slice_type is equal to B), the candidate zeroCand_m with m equal to (numCurrMergeCand - numInputMergeCand) is added at the end of mergeCandList, i.e. mergeCandList[numCurrMergeCand] is set equal to zeroCand_m, and the reference indices, the

prediction list utilization flags, and the motion vectors of zeroCand_m are derived as follows and numCurrMergeCand is incremented by 1:

$$\text{refIdxL0zeroCand}_m = (\text{zeroIdx} < \text{numRefIdx}) ? \text{zeroIdx} : 0 \quad (8-161)$$

$$\text{refIdxL1zeroCand}_m = (\text{zeroIdx} < \text{numRefIdx}) ? \text{zeroIdx} : 0 \quad (8-162)$$

$$\text{predFlagL0zeroCand}_m = 1 \quad (8-163)$$

$$\text{predFlagL1zeroCand}_m = 1 \quad (8-164)$$

$$\text{mvL0zeroCand}_m[0] = 0 \quad (8-165)$$

$$\text{mvL0zeroCand}_m[1] = 0 \quad (8-166)$$

$$\text{mvL1zeroCand}_m[0] = 0 \quad (8-167)$$

$$\text{mvL1zeroCand}_m[1] = 0 \quad (8-168)$$

$$\text{numCurrMergeCand} = \text{numCurrMergeCand} + 1 \quad (8-169)$$

2. The variable zeroIdx is incremented by 1.

8.5.3.2.6 Derivation process for luma motion vector prediction

Inputs to this process are

- a luma location (xCb, yCb) of the top-left sample of the current luma coding block relative to the top-left luma sample of the current picture,
- a variable nCbS specifying the size of the current luma coding block,
- a luma location (xPb, yPb) specifying the top-left sample of the current luma prediction block relative to the top-left luma sample of the current picture,
- two variables nPbW and nPbH specifying the width and the height of the luma prediction block,
- the reference index of the current prediction unit partition refIdxLX, with X being 0 or 1, and
- a variable partIdx specifying the index of the current prediction unit within the current coding unit.

Output of this process is the prediction mvplX of the motion vector mvLX, with X being 0 or 1.

The motion vector predictor mvplX is derived in the following ordered steps:

1. The derivation process for motion vector predictor candidates from neighbouring prediction unit partitions in 8.5.3.2.7 is invoked with the luma coding block location (xCb, yCb), the coding block size nCbS, the luma prediction block location (xPb, yPb), the luma prediction block width nPbW, the luma prediction block height nPbH, refIdxLX, with X being 0 or 1, and the partition index partIdx as inputs, and the availability flags availableFlagLXN and the motion vectors mvLXN, with N being replaced by A or B, as output.
2. If both availableFlagLXA and availableFlagLXB are equal to 1 and mvLXA is not equal to mvLXB, availableFlagLXCol is set equal to 0. Otherwise, the derivation process for temporal luma motion vector prediction in 8.5.3.2.8 is invoked with luma prediction block location (xPb, yPb), the luma prediction block width nPbW, the luma prediction block height nPbH, and refIdxLX, with X being 0 or 1, as inputs, and with the output being the availability flag availableFlagLXCol and the temporal motion vector predictor mvLXCol.

3. The motion vector predictor candidate list, `mvpListLX`, is constructed as follows:

```

i = 0
if( availableFlagLXA ) {
    mvpListLX[ i++ ] = mvLXA
    if( availableFlagLXB && ( mvLXA != mvLXB ) )
        mvpListLX[ i++ ] = mvLXB
} else if( availableFlagLXB )
    mvpListLX[ i++ ] = mvLXB
if( i < 2 && availableFlagLXCol )
    mvpListLX[ i++ ] = mvLXCol
while( i < 2 ) {
    mvpListLX[ i ][ 0 ] = 0
    mvpListLX[ i ][ 1 ] = 0
    i++
}

```

(8-170)

4. The motion vector of `mvpListLX[mvp_lX_flag[xPb][yPb]]` is assigned to `mvLX`.

8.5.3.2.7 Derivation process for motion vector predictor candidates

Inputs to this process are

- a luma location (`xCb, yCb`) of the top-left sample of the current luma coding block relative to the top-left luma sample of the current picture,
- a variable `nCbS` specifying the size of the current luma coding block,
- a luma location (`xPb, yPb`) specifying the top-left sample of the current luma prediction block relative to the top-left luma sample of the current picture,
- two variables `nPbW` and `nPbH` specifying the width and the height of the luma prediction block,
- the reference index of the current prediction unit partition `refIdxLX`, with `X` being 0 or 1, and
- a variable `partIdx` specifying the index of the current prediction unit within the current coding unit.

Outputs of this process are (with `N` being replaced by `A` or `B`)

- the motion vectors `mvLXN` of the neighbouring prediction units, and
- the availability flags `availableFlagLXN` of the neighbouring prediction units.

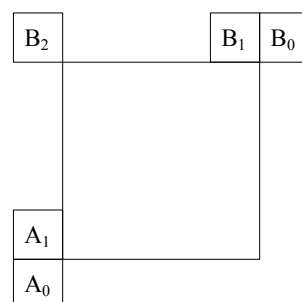

Figure 8-3 — Spatial motion vector neighbours (informative)

The variable `currPb` specifies the current luma prediction block at luma location (`xPb, yPb`) and the variable `currPic` specifies the current picture.

ISO/IEC 23008-2:2017(E)

The variable $isScaledFlagLX$, with X being 0 or 1, is set equal to 0.

The motion vector $mvLXA$ and the availability flag $availableFlagLXA$ are derived in the following ordered steps:

1. The sample location $(xNbA_0, yNbA_0)$ is set equal to $(xPb - 1, yPb + nPbH)$ and the sample location $(xNbA_1, yNbA_1)$ is set equal to $(xNbA_0, yNbA_0 - 1)$.
2. The availability flag $availableFlagLXA$ is set equal to 0 and both components of $mvLXA$ are set equal to 0.
3. The availability derivation process for a prediction block as specified in 6.4.2 is invoked with the luma location (xCb, yCb) , the current luma coding block size $nCbS$, the luma prediction block location (xPb, yPb) , the luma prediction block width $nPbW$, the luma prediction block height $nPbH$, the luma location $(xNbY, yNbY)$ set equal to $(xNbA_0, yNbA_0)$, and the partition index $partIdx$ as inputs, and the output is assigned to the prediction block availability flag $availableA_0$.
4. The availability derivation process for a prediction block as specified in 6.4.2 is invoked with the luma location (xCb, yCb) , the current luma coding block size $nCbS$, the luma prediction block location (xPb, yPb) , the luma prediction block width $nPbW$, the luma prediction block height $nPbH$, the luma location $(xNbY, yNbY)$ set equal to $(xNbA_1, yNbA_1)$, and the partition index $partIdx$ as inputs, and the output is assigned to the prediction block availability flag $availableA_1$.
5. When $availableA_0$ or $availableA_1$ is equal to TRUE, the variable $isScaledFlagLX$ is set equal to 1.
6. The following applies for $(xNbA_k, yNbA_k)$ from $(xNbA_0, yNbA_0)$ to $(xNbA_1, yNbA_1)$:

— When $availableA_k$ is equal to TRUE and $availableFlagLXA$ is equal to 0, the following apply:

- If $PredFlagLX[xNbA_k][yNbA_k]$ is equal to 1 and $DiffPicOrderCnt(RefPicListX[RefIdxLX[xNbA_k][yNbA_k]], RefPicListX[refIdxLX])$ is equal to 0, $availableFlagLXA$ is set equal to 1 and the following applies:

$$mvLXA = MvLX[xNbA_k][yNbA_k] \quad (8-171)$$

- Otherwise, when $PredFlagLY[xNbA_k][yNbA_k]$ (with $Y = !X$) is equal to 1 and $DiffPicOrderCnt(RefPicListY[RefIdxLY[xNbA_k][yNbA_k]], RefPicListX[refIdxLX])$ is equal to 0, $availableFlagLXA$ is set equal to 1 and the following applies:

$$mvLXA \in MvLY[xNbA_k][yNbA_k] \quad (8-172)$$

7. When $availableFlagLXA$ is equal to 0, the following applies for $(xNbA_k, yNbA_k)$ from $(xNbA_0, yNbA_0)$ to $(xNbA_1, yNbA_1)$ or until $availableFlagLXA$ is equal to 1:

— When $availableA_k$ is equal to TRUE and $availableFlagLXA$ is equal to 0, the following apply:

- If $PredFlagLX[xNbA_k][yNbA_k]$ is equal to 1 and $LongTermRefPic(currPic, currPb, refIdxLX, RefPicListX)$ is equal to $LongTermRefPic(currPic, currPb, RefIdxLX[xNbA_k][yNbA_k], RefPicListX)$, $availableFlagLXA$ is set equal to 1 and the following assignments are made:

$$mvLXA = MvLX[xNbA_k][yNbA_k] \quad (8-173)$$

$$refIdxA = RefIdxLX[xNbA_k][yNbA_k] \quad (8-174)$$

$$refPicListA = RefPicListX \quad (8-175)$$

- Otherwise, when $\text{PredFlagLY}[xNbA_k][yNbA_k]$ (with $Y = !X$) is equal to 1 and $\text{LongTermRefPic}(\text{currPic}, \text{currPb}, \text{refIdxLX}, \text{RefPicListX})$ is equal to $\text{LongTermRefPic}(\text{currPic}, \text{currPb}, \text{refIdxLY}[xNbA_k][yNbA_k], \text{RefPicListY})$, availableFlagLXA is set equal to 1 and the following assignments are made:

$$\text{mvLXA} = \text{MvLY}[xNbA_k][yNbA_k] \quad (8-176)$$

$$\text{refIdxA} = \text{RefIdxLY}[xNbA_k][yNbA_k] \quad (8-177)$$

$$\text{refPicListA} = \text{RefPicListY} \quad (8-178)$$

- When availableFlagLXA is equal to 1, $\text{DiffPicOrderCnt}(\text{refPicListA}[\text{refIdxA}], \text{RefPicListX}[\text{refIdxLX}])$ is not equal to 0, and both $\text{refPicListA}[\text{refIdxA}]$ and $\text{RefPicListX}[\text{refIdxLX}]$ are short-term reference pictures, mvLXA is derived as follows:

$$\text{tx} = (16384 + (\text{Abs}(\text{td}) \gg 1)) / \text{td} \quad (8-179)$$

$$\text{distScaleFactor} = \text{Clip3}(-4096, 4095, (\text{tb} * \text{tx} + 32) \gg 6) \quad (8-180)$$

$$\text{mvLXA} = \text{Clip3}(-32768, 32767, \text{Sign}(\text{distScaleFactor} * \text{mvLXA}) * ((\text{Abs}(\text{distScaleFactor} * \text{mvLXA}) + 127) \gg 8)) \quad (8-181)$$

where td and tb are derived as follows:

$$\text{td} = \text{Clip3}(-128, 127, \text{DiffPicOrderCnt}(\text{currPic}, \text{refPicListA}[\text{refIdxA}])) \quad (8-182)$$

$$\text{tb} = \text{Clip3}(-128, 127, \text{DiffPicOrderCnt}(\text{currPic}, \text{RefPicListX}[\text{refIdxLX}])) \quad (8-183)$$

The motion vector mvLXB and the availability flag availableFlagLXB are derived in the following ordered steps:

1. The sample locations $(xNbB_0, yNbB_0)$, $(xNbB_1, yNbB_1)$, and $(xNbB_2, yNbB_2)$ are set equal to $(xPb + nPbW, yPb - 1)$, $(xPb + nPbW - 1, yPb - 1)$, and $(xPb - 1, yPb - 1)$, respectively.
2. The availability flag availableFlagLXB is set equal to 0 and the both components of mvLXB are set equal to 0.
3. The following applies for $(xNbB_k, yNbB_k)$ from $(xNbB_0, yNbB_0)$ to $(xNbB_2, yNbB_2)$:
 - The availability derivation process for a prediction block as specified in 6.4.2 is invoked with the luma location (xCb, yCb) , the current luma coding block size $nCbS$, the luma prediction block location (xPb, yPb) , the luma prediction block width $nPbW$, the luma prediction block height $nPbH$, the luma location $(xNbY, yNbY)$ set equal to $(xNbB_k, yNbB_k)$, and the partition index partIdx as inputs, and the output is assigned to the prediction block availability flag availableB_k .

- When availableB_k is equal to TRUE and availableFlagLXB is equal to 0, the following apply:

- If $\text{PredFlagLX}[xNbB_k][yNbB_k]$ is equal to 1, and $\text{DiffPicOrderCnt}(\text{RefPicListX}[\text{refIdxLX}[xNbB_k][yNbB_k]], \text{RefPicListX}[\text{refIdxLX}])$ is equal to 0, availableFlagLXB is set equal to 1 and the following assignments are made:

$$\text{mvLXB} = \text{MvLX}[xNbB_k][yNbB_k] \quad (8-184)$$

$$\text{refIdxB} = \text{RefIdxLX}[xNbB_k][yNbB_k] \quad (8-185)$$

- Otherwise, when $\text{PredFlagLY}[xNbB_k][yNbB_k]$ (with $Y = !X$) is equal to 1 and $\text{DiffPicOrderCnt}(\text{RefPicListY}[\text{RefIdxLY}[xNbB_k][yNbB_k]], \text{RefPicListX}[\text{refIdxLX}])$ is equal to 0, availableFlagLXB is set equal to 1 and the following assignments are made:

$$\text{mvLXB} = \text{MvLY}[xNbB_k][yNbB_k] \quad (8-186)$$

$$\text{refIdxB} = \text{RefIdxLY}[xNbB_k][yNbB_k] \quad (8-187)$$

4. When isScaledFlagLX is equal to 0 and availableFlagLXB is equal to 1, availableFlagLXA is set equal to 1 and the following applies:

$$\text{mvLXA} = \text{mvLXB} \quad (8-188)$$

5. When isScaledFlagLX is equal to 0, availableFlagLXB is set equal to 0 and the following applies for $(xNbB_k, yNbB_k)$ from $(xNbB_0, yNbB_0)$ to $(xNbB_2, yNbB_2)$ or until availableFlagLXB is equal to 1:

- The availability derivation process for a prediction block as specified in 6.4.2 is invoked with the luma location (xCb, yCb) , the current luma coding block size $nCbS$, the luma location (xPb, yPb) , the luma prediction block width $nPbW$, the luma prediction block height $nPbH$, the luma location $(xNbY, yNbY)$ set equal to $(xNbB_k, yNbB_k)$, and the partition index partIdx as inputs, and the output is assigned to the prediction block availability flag availableB_k .
- When availableB_k is equal to TRUE and availableFlagLXB is equal to 0, the following apply:

- If $\text{PredFlagLX}[xNbB_k][yNbB_k]$ is equal to 1 and $\text{LongTermRefPic}(\text{currPic}, \text{currPb}, \text{refIdxLX}, \text{RefPicListX})$ is equal to $\text{LongTermRefPic}(\text{currPic}, \text{currPb}, \text{RefIdxLX}[xNbB_k][yNbB_k], \text{RefPicListX})$, availableFlagLXB is set equal to 1 and the following assignments are made:

$$\text{mvLXB} = \text{MvLX}[xNbB_k][yNbB_k] \quad (8-189)$$

$$\text{refIdxB} = \text{RefIdxLX}[xNbB_k][yNbB_k] \quad (8-190)$$

$$\text{refPicListB} = \text{RefPicListX} \quad (8-191)$$

- Otherwise, when $\text{PredFlagLY}[xNbB_k][yNbB_k]$ (with $Y = !X$) is equal to 1 and $\text{LongTermRefPic}(\text{currPic}, \text{currPb}, \text{refIdxLX}, \text{RefPicListX})$ is equal to $\text{LongTermRefPic}(\text{currPic}, \text{currPb}, \text{RefIdxLY}[xNbB_k][yNbB_k], \text{RefPicListY})$, availableFlagLXB is set equal to 1 and the following assignments are made:

$$\text{mvLXB} = \text{MvLY}[xNbB_k][yNbB_k] \quad (8-192)$$

$$\text{refIdxB} = \text{RefIdxLY}[xNbB_k][yNbB_k] \quad (8-193)$$

$$\text{refPicListB} = \text{RefPicListY} \quad (8-194)$$

- When availableFlagLXB is equal to 1, $\text{DiffPicOrderCnt}(\text{refPicListB}[\text{refIdxB}], \text{RefPicListX}[\text{refIdxLX}])$ is not equal to 0, and both $\text{refPicListB}[\text{refIdxB}]$ and $\text{RefPicListX}[\text{refIdxLX}]$ are short-term reference pictures, mvLXB is derived as follows:

$$\text{tx} = (16384 + (\text{Abs}(\text{td}) \gg 1)) / \text{td} \quad (8-195)$$

$$\text{distScaleFactor} = \text{Clip3}(-4096, 4095, (\text{tb} * \text{tx} + 32) \gg 6) \quad (8-196)$$

$$\text{mvLXB} = \text{Clip3}(-32768, 32767, \text{Sign}(\text{distScaleFactor} * \text{mvLXB}) * ((\text{Abs}(\text{distScaleFactor} * \text{mvLXB}) + 127) \gg 8)) \quad (8-197)$$

where td and tb are derived as follows:

$$td = \text{Clip3}(-128, 127, \text{DiffPicOrderCnt}(\text{currPic}, \text{refPicListB}[\text{refIdxB}])) \quad (8-198)$$

$$tb = \text{Clip3}(-128, 127, \text{DiffPicOrderCnt}(\text{currPic}, \text{RefPicListX}[\text{refIdxLX}])) \quad (8-199)$$

8.5.3.2.8 Derivation process for temporal luma motion vector prediction

Inputs to this process are

- a luma location (xPb, yPb) specifying the top-left sample of the current luma prediction block relative to the top-left luma sample of the current picture,
- two variables $nPbW$ and $nPbH$ specifying the width and the height of the luma prediction block, and
- a reference index $refIdxLX$, with X being 0 or 1.

Outputs of this process are

- the motion vector prediction $mvLXCol$, and
- the availability flag $availableFlagLXCol$.

The variable $currPb$ specifies the current luma prediction block at luma location (xPb, yPb) .

The variables $mvLXCol$ and $availableFlagLXCol$ are derived as follows:

- If $\text{slice_temporal_mvp_enabled_flag}$ is equal to 0, both components of $mvLXCol$ are set equal to 0 and $availableFlagLXCol$ is set equal to 0.
- Otherwise ($\text{slice_temporal_mvp_enabled_flag}$ is equal to 1), the following ordered steps apply:
 1. The bottom right collocated motion vector is derived as follows:

$$xColBr = xPb + nPbW \quad (8-200)$$

$$yColBr = yPb + nPbH \quad (8-201)$$

- If $yPb \gg \text{CtbLog2SizeY}$ is equal to $yColBr \gg \text{CtbLog2SizeY}$, $yColBr$ is less than $\text{pic_height_in_luma_samples}$, and $xColBr$ is less than $\text{pic_width_in_luma_samples}$, the following apply:
 - The variable $colPb$ specifies the luma prediction block covering the modified location given by $((xColBr \gg 4) \ll 4, (yColBr \gg 4) \ll 4)$ inside the collocated picture specified by $ColPic$.
 - The luma location $(xColPb, yColPb)$ is set equal to the top-left sample of the collocated luma prediction block specified by $colPb$ relative to the top-left luma sample of the collocated picture specified by $ColPic$.
 - The derivation process for collocated motion vectors as specified in 8.5.3.2.9 is invoked with $currPb$, $colPb$, $(xColPb, yColPb)$, and $refIdxLX$ as inputs, and the output is assigned to $mvLXCol$ and $availableFlagLXCol$.
- Otherwise, both components of $mvLXCol$ are set equal to 0 and $availableFlagLXCol$ is set equal to 0.

2. When availableFlagLXCol is equal to 0, the central collocated motion vector is derived as follows:

$$xColCtr = xPb + (nPbW \gg 1) \quad (8-202)$$

$$yColCtr = yPb + (nPbH \gg 1) \quad (8-203)$$

- The variable colPb specifies the luma prediction block covering the modified location given by $((xColCtr \gg 4) \ll 4, (yColCtr \gg 4) \ll 4)$ inside the collocated picture specified by ColPic.
- The luma location $(xColPb, yColPb)$ is set equal to the top-left sample of the collocated luma prediction block specified by colPb relative to the top-left luma sample of the collocated picture specified by ColPic.
- The derivation process for collocated motion vectors as specified in 8.5.3.2.9 is invoked with currPb, colPb, $(xColPb, yColPb)$, and refIdxLX as inputs, and the output is assigned to mvLXCol and availableFlagLXCol.

8.5.3.2.9 Derivation process for collocated motion vectors

Inputs to this process are

- a variable currPb specifying the current prediction block,
- a variable colPb specifying the collocated prediction block inside the collocated picture specified by ColPic,
- a luma location $(xColPb, yColPb)$ specifying the top-left sample of the collocated luma prediction block specified by colPb relative to the top-left luma sample of the collocated picture specified by ColPic, and
- a reference index refIdxLX, with X being 0 or 1.

Outputs of this process are

- the motion vector prediction mvLXCol, and
- the availability flag availableFlagLXCol.

The variable currPic specifies the current picture.

The arrays predFlagL0Col[x][y], mvL0Col[x][y], and refIdxL0Col[x][y] are set equal to PredFlagL0[x][y], MvL0[x][y], and RefIdxL0[x][y], respectively, of the collocated picture specified by ColPic, and the arrays predFlagL1Col[x][y], mvL1Col[x][y], and refIdxL1Col[x][y] are set equal to PredFlagL1[x][y], MvL1[x][y], and RefIdxL1[x][y], respectively, of the collocated picture specified by ColPic.

The variables mvLXCol and availableFlagLXCol are derived as follows:

- If colPb is coded in an intra prediction mode, both components of mvLXCol are set equal to 0 and availableFlagLXCol is set equal to 0.
- Otherwise, the motion vector mvCol, the reference index refIdxCol, and the reference list identifier listCol are derived as follows:
 - If predFlagL0Col[xColPb][yColPb] is equal to 0, mvCol, refIdxCol, and listCol are set equal to mvL1Col[xColPb][yColPb], refIdxL1Col[xColPb][yColPb], and L1, respectively.

- Otherwise, if $\text{predFlagL0Col}[x\text{ColPb}][y\text{ColPb}]$ is equal to 1 and $\text{predFlagL1Col}[x\text{ColPb}][y\text{ColPb}]$ is equal to 0, mvCol , refIdxCol , and listCol are set equal to $\text{mvL0Col}[x\text{ColPb}][y\text{ColPb}]$, $\text{refIdxL0Col}[x\text{ColPb}][y\text{ColPb}]$, and $L0$, respectively.
- Otherwise ($\text{predFlagL0Col}[x\text{ColPb}][y\text{ColPb}]$ is equal to 1 and $\text{predFlagL1Col}[x\text{ColPb}][y\text{ColPb}]$ is equal to 1), the following assignments are made:
 - If $\text{NoBackwardPredFlag}$ is equal to 1, mvCol , refIdxCol , and listCol are set equal to $\text{mvLXCol}[x\text{ColPb}][y\text{ColPb}]$, $\text{refIdxLXCol}[x\text{ColPb}][y\text{ColPb}]$, and LX , respectively.
 - Otherwise, mvCol , refIdxCol , and listCol are set equal to $\text{mvLNCol}[x\text{ColPb}][y\text{ColPb}]$, $\text{refIdxLNCol}[x\text{ColPb}][y\text{ColPb}]$, and LN , respectively, with N being the value of $\text{collocated_from_l0_flag}$.

And mvLXCol and $\text{availableFlagLXCol}$ are derived as follows:

- If $\text{LongTermRefPic}(\text{currPic}, \text{currPb}, \text{refIdxLX}, LX)$ is not equal to $\text{LongTermRefPic}(\text{ColPic}, \text{colPb}, \text{refIdxCol}, \text{listCol})$, both components of mvLXCol are set equal to 0 and $\text{availableFlagLXCol}$ is set equal to 0.
- Otherwise, the variable $\text{availableFlagLXCol}$ is set equal to 1, $\text{refPicListCol}[\text{refIdxCol}]$ is set to be the picture with reference index refIdxCol in the reference picture list listCol of the slice containing prediction block colPb in the collocated picture specified by ColPic , and the following apply:

$$\text{colPocDiff} = \text{DiffPicOrderCnt}(\text{ColPic}, \text{refPicListCol}[\text{refIdxCol}]) \quad (8-204)$$

$$\text{currPocDiff} = \text{DiffPicOrderCnt}(\text{currPic}, \text{RefPicListX}[\text{refIdxLX}]) \quad (8-205)$$

- If $\text{RefPicListX}[\text{refIdxLX}]$ is a long-term reference picture, or colPocDiff is equal to currPocDiff , mvLXCol is derived as follows:

$$\text{mvLXCol} = \text{mvCol} \quad (8-206)$$

- Otherwise, mvLXCol is derived as a scaled version of the motion vector mvCol as follows:

$$\text{tx} = (16384 + (\text{Abs}(\text{td}) \gg 1)) / \text{td} \quad (8-207)$$

$$\text{distScaleFactor} = \text{Clip3}(-4096, 4095, (\text{tb} * \text{tx} + 32) \gg 6) \quad (8-208)$$

$$\text{mvLXCol} = \text{Clip3}(-32768, 32767, \text{Sign}(\text{distScaleFactor} * \text{mvCol}) * ((\text{Abs}(\text{distScaleFactor} * \text{mvCol}) + 127) \gg 8)) \quad (8-209)$$

where td and tb are derived as follows:

$$\text{td} = \text{Clip3}(-128, 127, \text{colPocDiff}) \quad (8-210)$$

$$\text{tb} = \text{Clip3}(-128, 127, \text{currPocDiff}) \quad (8-211)$$

8.5.3.2.10 Derivation process for chroma motion vectors

This process is invoked when ChromaArrayType is not equal to 0.

Input to this process is a luma motion vector mvLX .

Output of this process is a chroma motion vector mvCLX .

A chroma motion vector is derived from the corresponding luma motion vector.

For the derivation of the chroma motion vector mvCLX , the following apply:

ISO/IEC 23008-2:2017(E)

$$\text{mvCLX}[0] = \text{mvLX}[0] * 2 / \text{SubWidthC} \quad (8-212)$$

$$\text{mvCLX}[1] = \text{mvLX}[1] * 2 / \text{SubHeightC} \quad (8-213)$$

8.5.3.3 Decoding process for inter prediction samples

8.5.3.3.1 General

Inputs to this process are

- a luma location (x_{Cb}, y_{Cb}) specifying the top-left sample of the current luma coding block relative to the top-left luma sample of the current picture,
- a luma location (x_{Bl}, y_{Bl}) specifying the top-left sample of the current luma prediction block relative to the top-left sample of the current luma coding block,
- a variable n_{CbS} specifying the size of the current luma coding block,
- two variables n_{PbW} and n_{PbH} specifying the width and the height of the luma prediction block,
- the luma motion vectors $mvL0$ and $mvL1$,
- when ChromaArrayType is not equal to 0, the chroma motion vectors $mvCL0$ and $mvCL1$,
- the reference indices refIdxL0 and refIdxL1 , and
- the prediction list utilization flags, predFlagL0 , and predFlagL1 .

Outputs of this process are

- an $(n_{CbS_L}) \times (n_{CbS_L})$ array predSamples_L of luma prediction samples, where n_{CbS_L} is derived as specified below,
- when ChromaArrayType is not equal to 0, an $(n_{CbSw_C}) \times (n_{CbSh_C})$ array predSamples_{Cb} of chroma prediction samples for the component Cb , where n_{CbSw_C} and n_{CbSh_C} are derived as specified below, and
- when ChromaArrayType is not equal to 0, an $(n_{CbSw_C}) \times (n_{CbSh_C})$ array predSamples_{Cr} of chroma prediction samples for the component Cr , where n_{CbSw_C} and n_{CbSh_C} are derived as specified below.

The variable n_{CbS_L} is set equal to n_{CbS} . When ChromaArrayType is not equal to 0, the variable n_{CbSw_C} is set equal to $n_{CbS} / \text{SubWidthC}$ and the variable n_{CbSh_C} is set equal to $n_{CbS} / \text{SubHeightC}$.

Let predSamplesL0_L and predSamplesL1_L be $(n_{PbW}) \times (n_{PbH})$ arrays of predicted luma sample values and, when ChromaArrayType is not equal to 0, $\text{predSamplesL0}_{Cb}$, $\text{predSamplesL1}_{Cb}$, $\text{predSamplesL0}_{Cr}$, and $\text{predSamplesL1}_{Cr}$ be $(n_{PbW} / \text{SubWidthC}) \times (n_{PbH} / \text{SubHeightC})$ arrays of predicted chroma sample values.

For X being each of 0 and 1, when predFlagLX is equal to 1, the following apply:

- The reference picture consisting of an ordered two-dimensional array refPicLX_L of luma samples and, when ChromaArrayType is not equal to 0, two ordered two-dimensional arrays refPicLX_{Cb} and refPicLX_{Cr} of chroma samples is derived by invoking the process specified in 8.5.3.3.2 with refIdxLX as input.
- The array predSamplesLX_L and, when ChromaArrayType is not equal to 0, the arrays $\text{predSamplesLX}_{Cb}$ and $\text{predSamplesLX}_{Cr}$ are derived by invoking the fractional sample interpolation process specified in 8.5.3.3.3 with the luma locations (x_{Cb}, y_{Cb}) and (x_{Bl}, y_{Bl}), the luma

prediction block width $nPbW$, the luma prediction block height $nPbH$, the motion vectors $mvLX$ and, when $ChromaArrayType$ is not equal to 0, $mvCLX$, and the reference arrays $refPicLX_L$, $refPicLX_{Cb}$, and $refPicLX_{Cr}$ as inputs.

The prediction samples inside the current luma prediction block, $predSamples_L[x_L + xBl][y_L + yBl]$ with $x_L = 0..nPbW - 1$ and $y_L = 0..nPbH - 1$, are derived by invoking the weighted sample prediction process specified in 8.5.3.3.4 with the prediction block width $nPbW$, the prediction block height $nPbH$, and the sample arrays $predSamplesL0_L$ and $predSamplesL1_L$, and the variables $predFlagL0$, $predFlagL1$, $refIdxL0$, $refIdxL1$, and $cIdx$ equal to 0 as inputs.

When $ChromaArrayType$ is not equal to 0, the prediction samples inside the current chroma component Cb prediction block, $predSamples_{Cb}[x_C + xBl / SubWidthC][y_C + yBl / SubHeightC]$ with $x_C = 0..nPbW / SubWidthC - 1$ and $y_C = 0..nPbH / SubHeightC - 1$, are derived by invoking the weighted sample prediction process specified in 8.5.3.3.4 with the prediction block width $nPbW$ set equal to $nPbW / SubWidthC$, the prediction block height $nPbH$ set equal to $nPbH / SubHeightC$, the sample arrays $predSamplesL0_{Cb}$ and $predSamplesL1_{Cb}$, and the variables $predFlagL0$, $predFlagL1$, $refIdxL0$, $refIdxL1$, and $cIdx$ equal to 1 as inputs.

When $ChromaArrayType$ is not equal to 0, the prediction samples inside the current chroma component Cr prediction block, $predSamples_{Cr}[x_C + xBl / SubWidthC][y_C + yBl / SubHeightC]$ with $x_C = 0..nPbW / SubWidthC - 1$ and $y_C = 0..nPbH / SubHeightC - 1$, are derived by invoking the weighted sample prediction process specified in 8.5.3.3.4 with the prediction block width $nPbW$ set equal to $nPbW / SubWidthC$, the prediction block height $nPbH$ set equal to $nPbH / SubHeightC$, the sample arrays $predSamplesL0_{Cr}$ and $predSamplesL1_{Cr}$, and the variables $predFlagL0$, $predFlagL1$, $refIdxL0$, $refIdxL1$, and $cIdx$ equal to 2 as inputs.

8.5.3.3.2 Reference picture selection process

Input to this process is a reference index $refIdxLX$.

Output of this process is a reference picture consisting of a two-dimensional array of luma samples $refPicLX_L$ and, when $ChromaArrayType$ is not equal to 0, two two-dimensional arrays of chroma samples $refPicLX_{Cb}$ and $refPicLX_{Cr}$.

The output reference picture $RefPicListX[refIdxLX]$ consists of a $pic_width_in_luma_samples$ by $pic_height_in_luma_samples$ array of luma samples $refPicLX_L$ and, when $ChromaArrayType$ is not equal to 0, two $PicWidthInSamplesC$ by $PicHeightInSamplesC$ arrays of chroma samples $refPicLX_{Cb}$ and $refPicLX_{Cr}$.

The reference picture sample arrays $refPicLX_L$, $refPicLX_{Cb}$, and $refPicLX_{Cr}$ correspond to decoded sample arrays S_L , S_{Cb} , and S_{Cr} derived in 8.7 for a previously-decoded picture.

8.5.3.3.3 Fractional sample interpolation process

8.5.3.3.3.1 General

Inputs to this process are

- a luma location (xCb , yCb) specifying the top-left sample of the current luma coding block relative to the top-left luma sample of the current picture,
- a luma location (xBl , yBl) specifying the top-left sample of the current luma prediction block relative to the top-left sample of the current luma coding block,
- two variables $nPbW$ and $nPbH$ specifying the width and the height of the luma prediction block,
- a luma motion vector $mvLX$ given in quarter-luma-sample units,
- when $ChromaArrayType$ is not equal to 0, a chroma motion vector $mvCLX$ given in eighth-chroma-sample units, and

ISO/IEC 23008-2:2017(E)

- the selected reference picture sample array refPicLX_L and, when ChromaArrayType is not equal to 0, the arrays refPicLX_{Cb} , and refPicLX_{Cr} .

Outputs of this process are

- an $(n\text{PbW}) \times (n\text{PbH})$ array predSamplesLX_L of prediction luma sample values, and
- when ChromaArrayType is not equal to 0, two $(n\text{PbW} / \text{SubWidthC}) \times (n\text{PbH} / \text{SubHeightC})$ arrays $\text{predSamplesLX}_{Cb}$, and $\text{predSamplesLX}_{Cr}$ of prediction chroma sample values.

The location $(x\text{Pb}, y\text{Pb})$ given in full-sample units of the upper-left luma samples of the current prediction block relative to the upper-left luma sample location of the given reference sample arrays is derived as follows:

$$x\text{Pb} = x\text{Cb} + x\text{Bl} \quad (8-214)$$

$$y\text{Pb} = y\text{Cb} + y\text{Bl} \quad (8-215)$$

Let $(x\text{Int}_L, y\text{Int}_L)$ be a luma location given in full-sample units and $(x\text{Frac}_L, y\text{Frac}_L)$ be an offset given in quarter-sample units. These variables are used only in this subclause for specifying fractional-sample locations inside the reference sample arrays refPicLX_L , refPicLX_{Cb} , and refPicLX_{Cr} .

For each luma sample location $(x_L = 0..n\text{PbW} - 1, y_L = 0..n\text{PbH} - 1)$ inside the prediction luma sample array predSamplesLX_L , the corresponding prediction luma sample value $\text{predSamplesLX}_L[x_L][y_L]$ is derived as follows:

- The variables $x\text{Int}_L, y\text{Int}_L, x\text{Frac}_L$, and $y\text{Frac}_L$ are derived as follows:

$$x\text{Int}_L = x\text{Pb} + (\text{mvLX}[0] \gg 2) + x_L \quad (8-216)$$

$$y\text{Int}_L = y\text{Pb} + (\text{mvLX}[1] \gg 2) + y_L \quad (8-217)$$

$$x\text{Frac}_L = \text{mvLX}[0] \& 3 \quad (8-218)$$

$$y\text{Frac}_L = \text{mvLX}[1] \& 3 \quad (8-219)$$

- The prediction luma sample value $\text{predSamplesLX}_L[x_L][y_L]$ is derived by invoking the process specified in 8.5.3.3.2 with $(x\text{Int}_L, y\text{Int}_L)$, $(x\text{Frac}_L, y\text{Frac}_L)$, and refPicLX_L as inputs.

When ChromaArrayType is not equal to 0, the following applies.

Let $(x\text{Int}_C, y\text{Int}_C)$ be a chroma location given in full-sample units and $(x\text{Frac}_C, y\text{Frac}_C)$ be an offset given in one-eighth sample units. These variables are used only in this subclause for specifying general fractional-sample locations inside the reference sample arrays refPicLX_{Cb} and refPicLX_{Cr} .

For each chroma sample location $(x_C = 0..n\text{PbW} / \text{SubWidthC} - 1, y_C = 0..n\text{PbH} / \text{SubHeightC} - 1)$ inside the prediction chroma sample arrays $\text{predSamplesLX}_{Cb}$ and $\text{predSamplesLX}_{Cr}$, the corresponding prediction chroma sample values $\text{predSamplesLX}_{Cb}[x_C][y_C]$ and $\text{predSamplesLX}_{Cr}[x_C][y_C]$ are derived as follows:

- The variables $x\text{Int}_C, y\text{Int}_C, x\text{Frac}_C$, and $y\text{Frac}_C$ are derived as follows:

$$x\text{Int}_C = (x\text{Pb} / \text{SubWidthC}) + (\text{mvCLX}[0] \gg 3) + x_C \quad (8-220)$$

$$y\text{Int}_C = (y\text{Pb} / \text{SubHeightC}) + (\text{mvCLX}[1] \gg 3) + y_C \quad (8-221)$$

$$x\text{Frac}_C = \text{mvCLX}[0] \& 7 \quad (8-222)$$

$$y\text{Frac}_C = \text{mvCLX}[1] \& 7 \quad (8-223)$$

- The prediction sample value $\text{predSamplesLX}_{Cb}[x_c][y_c]$ is derived by invoking the process specified in 8.5.3.3.3.3 with $(xInt_c, yInt_c)$, $(xFrac_c, yFrac_c)$, and refPicLX_{Cb} as inputs.
- The prediction sample value $\text{predSamplesLX}_{Cr}[x_c][y_c]$ is derived by invoking the process specified in 8.5.3.3.3.3 with $(xInt_c, yInt_c)$, $(xFrac_c, yFrac_c)$, and refPicLX_{Cr} as inputs.

8.5.3.3.3.2 Luma sample interpolation process

Inputs to this process are

- a luma location in full-sample units $(xInt_L, yInt_L)$,
- a luma location in fractional-sample units $(xFrac_L, yFrac_L)$, and
- the luma reference sample array refPicLX_L .

Output of this process is a predicted luma sample value predSampleLX_L

$A_{-1,-1}$				$A_{0,-1}$	$a_{0,-1}$	$b_{0,-1}$	$c_{0,-1}$	$A_{1,-1}$				$A_{2,-1}$
$A_{-1,0}$				$A_{0,0}$	$a_{0,0}$	$b_{0,0}$	$c_{0,0}$	$A_{1,0}$				$A_{2,0}$
$d_{-1,0}$				$d_{0,0}$	$e_{0,0}$	$f_{0,0}$	$g_{0,0}$	$d_{1,0}$				$d_{2,0}$
$h_{-1,0}$				$h_{0,0}$	$i_{0,0}$	$j_{0,0}$	$k_{0,0}$	$h_{1,0}$				$h_{2,0}$
$n_{-1,0}$				$n_{0,0}$	$p_{0,0}$	$q_{0,0}$	$r_{0,0}$	$n_{1,0}$				$n_{2,0}$
$A_{-1,1}$				$A_{0,1}$	$a_{0,1}$	$b_{0,1}$	$c_{0,1}$	$A_{1,1}$				$A_{2,1}$
$A_{-1,2}$				$A_{0,2}$	$a_{0,2}$	$b_{0,2}$	$c_{0,2}$	$A_{1,2}$				$A_{2,2}$

Figure 8-4 — Integer samples (shaded blocks with upper-case letters) and fractional sample positions (un-shaded blocks with lower-case letters) for quarter sample luma interpolation

In Figure 8-4, the positions labelled with upper-case letters $A_{i,j}$ within shaded blocks represent luma samples at full-sample locations inside the given two-dimensional array refPicLX_L of luma samples. These samples may be used for generating the predicted luma sample value predSampleLX_L . The locations $(xA_{i,j}, yA_{i,j})$ for each of the corresponding luma samples $A_{i,j}$ inside the given array refPicLX_L of luma samples are derived as follows:

$$xA_{i,j} = \text{Clip3}(0, \text{pic_width_in_luma_samples} - 1, xInt_L + i) \tag{8-224}$$

ISO/IEC 23008-2:2017(E)

$$yA_{i,j} = \text{Clip3}(0, \text{pic_height_in_luma_samples} - 1, y\text{Int}_L + j) \tag{8-225}$$

The positions labelled with lower-case letters within un-shaded blocks represent luma samples at quarter-luma-sample fractional locations. The luma location offset in fractional-sample units ($x\text{Frac}_L, y\text{Frac}_L$) specifies which of the generated luma samples at full-sample and fractional-sample locations is assigned to the predicted luma sample value predSampleLX_L . This assignment is as specified in Table 8-8. The value of predSampleLX_L is the output.

The variables shift1 , shift2 , and shift3 are derived as follows:

- The variable shift1 is set equal to $\text{Min}(4, \text{BitDepth}_Y - 8)$, the variable shift2 is set equal to 6, and the variable shift3 is set equal to $\text{Max}(2, 14 - \text{BitDepth}_Y)$.

Given the luma samples $A_{i,j}$ at full-sample locations ($xA_{i,j}, yA_{i,j}$), the luma samples $a_{0,0}$ to $r_{0,0}$ at fractional sample positions are derived as follows:

- The samples labelled $a_{0,0}, b_{0,0}, c_{0,0}, d_{0,0}, h_{0,0}$, and $n_{0,0}$ are derived by applying an 8-tap filter to the nearest integer position samples as follows:

$$a_{0,0} = (-A_{-3,0} + 4 * A_{-2,0} - 10 * A_{-1,0} + 58 * A_{0,0} + 17 * A_{1,0} - 5 * A_{2,0} + A_{3,0}) \gg \text{shift1} \tag{8-226}$$

$$b_{0,0} = (-A_{-3,0} + 4 * A_{-2,0} - 11 * A_{-1,0} + 40 * A_{0,0} + 40 * A_{1,0} - 11 * A_{2,0} + 4 * A_{3,0} - A_{4,0}) \gg \text{shift1} \tag{8-227}$$

$$c_{0,0} = (A_{-2,0} - 5 * A_{-1,0} + 17 * A_{0,0} + 58 * A_{1,0} - 10 * A_{2,0} + 4 * A_{3,0} - A_{4,0}) \gg \text{shift1} \tag{8-228}$$

$$d_{0,0} = (-A_{0,-3} + 4 * A_{0,-2} - 10 * A_{0,-1} + 58 * A_{0,0} + 17 * A_{0,1} - 5 * A_{0,2} + A_{0,3}) \gg \text{shift1} \tag{8-229}$$

$$h_{0,0} = (-A_{0,-3} + 4 * A_{0,-2} - 11 * A_{0,-1} + 40 * A_{0,0} + 40 * A_{0,1} - 11 * A_{0,2} + 4 * A_{0,3} - A_{0,4}) \gg \text{shift1} \tag{8-230}$$

$$n_{0,0} = (A_{0,-2} - 5 * A_{0,-1} + 17 * A_{0,0} + 58 * A_{0,1} - 10 * A_{0,2} + 4 * A_{0,3} - A_{0,4}) \gg \text{shift1} \tag{8-231}$$

- The samples labelled $e_{0,0}, i_{0,0}, p_{0,0}, f_{0,0}, j_{0,0}, q_{0,0}, g_{0,0}, k_{0,0}$, and $r_{0,0}$ are derived by applying an 8-tap filter to the samples $a_{0,i}, b_{0,i}$ and $c_{0,i}$ with $i = -3..4$ in the vertical direction as follows:

$$e_{0,0} = (-a_{0,-3} + 4 * a_{0,-2} - 10 * a_{0,-1} + 58 * a_{0,0} + 17 * a_{0,1} - 5 * a_{0,2} + a_{0,3}) \gg \text{shift2} \tag{8-232}$$

$$i_{0,0} = (-a_{0,-3} + 4 * a_{0,-2} - 11 * a_{0,-1} + 40 * a_{0,0} + 40 * a_{0,1} - 11 * a_{0,2} + 4 * a_{0,3} - a_{0,4}) \gg \text{shift2} \tag{8-233}$$

$$p_{0,0} = (a_{0,-2} - 5 * a_{0,-1} + 17 * a_{0,0} + 58 * a_{0,1} - 10 * a_{0,2} + 4 * a_{0,3} - a_{0,4}) \gg \text{shift2} \tag{8-234}$$

$$f_{0,0} = (-b_{0,-3} + 4 * b_{0,-2} - 10 * b_{0,-1} + 58 * b_{0,0} + 17 * b_{0,1} - 5 * b_{0,2} + b_{0,3}) \gg \text{shift2} \tag{8-235}$$

$$j_{0,0} = (-b_{0,-3} + 4 * b_{0,-2} - 11 * b_{0,-1} + 40 * b_{0,0} + 40 * b_{0,1} - 11 * b_{0,2} + 4 * b_{0,3} - b_{0,4}) \gg \text{shift2} \tag{8-236}$$

$$q_{0,0} = (b_{0,-2} - 5 * b_{0,-1} + 17 * b_{0,0} + 58 * b_{0,1} - 10 * b_{0,2} + 4 * b_{0,3} - b_{0,4}) \gg \text{shift2} \tag{8-237}$$

$$g_{0,0} = (-c_{0,-3} + 4 * c_{0,-2} - 10 * c_{0,-1} + 58 * c_{0,0} + 17 * c_{0,1} - 5 * c_{0,2} + c_{0,3}) \gg \text{shift2} \tag{8-238}$$

$$k_{0,0} = (-c_{0,-3} + 4 * c_{0,-2} - 11 * c_{0,-1} + 40 * c_{0,0} + 40 * c_{0,1} - 11 * c_{0,2} + 4 * c_{0,3} - c_{0,4}) \gg \text{shift2} \tag{8-239}$$

$$r_{0,0} = (c_{0,-2} - 5 * c_{0,-1} + 17 * c_{0,0} + 58 * c_{0,1} - 10 * c_{0,2} + 4 * c_{0,3} - c_{0,4}) \gg \text{shift2} \tag{8-240}$$

Table 8-8 — Assignment of the luma prediction sample predSampleLX_L

xFracL	0	0	0	0	1	1	1	1	2	2	2	2	3	3	3	3
yFracL	0	1	2	3	0	1	2	3	0	1	2	3	0	1	2	3
predSampleLX_L	A << shift3	d	h	n	a	e	i	p	b	f	j	q	c	g	k	r

8.5.3.3.3 Chroma sample interpolation process

This process is only invoked when ChromaArrayType is not equal to 0.

Inputs to this process are

- a chroma location in full-sample units ($xInt_c, yInt_c$),
- a chroma location in eighth fractional-sample units ($xFrac_c, yFrac_c$), and
- the chroma reference sample array $refPicLX_c$.

Output of this process is a predicted chroma sample value $predSampleLX_c$

	$ha_{0,-1}$	$hb_{0,-1}$	$hc_{0,-1}$	$hd_{0,-1}$	$he_{0,-1}$	$hf_{0,-1}$	$hg_{0,-1}$	$hh_{0,-1}$	
$ah_{-1,0}$	$B_{0,0}$	$ab_{0,0}$	$ac_{0,0}$	$ad_{0,0}$	$ae_{0,0}$	$af_{0,0}$	$ag_{0,0}$	$ah_{0,0}$	$B_{1,0}$
$bh_{-1,0}$	$ba_{0,0}$	$bb_{0,0}$	$bc_{0,0}$	$bd_{0,0}$	$be_{0,0}$	$bf_{0,0}$	$bg_{0,0}$	$bh_{0,0}$	$ba_{1,0}$
$ch_{-1,0}$	$ca_{0,0}$	$cb_{0,0}$	$cc_{0,0}$	$cd_{0,0}$	$ce_{0,0}$	$cf_{0,0}$	$cg_{0,0}$	$ch_{0,0}$	$ca_{1,0}$
$dh_{-1,0}$	$da_{0,0}$	$db_{0,0}$	$dc_{0,0}$	$dd_{0,0}$	$de_{0,0}$	$df_{0,0}$	$dg_{0,0}$	$dh_{0,0}$	$da_{1,0}$
$eh_{-1,0}$	$ea_{0,0}$	$eb_{0,0}$	$ec_{0,0}$	$ed_{0,0}$	$ee_{0,0}$	$ef_{0,0}$	$eg_{0,0}$	$eh_{0,0}$	$ea_{1,0}$
$fh_{-1,0}$	$fa_{0,0}$	$fb_{0,0}$	$fc_{0,0}$	$fd_{0,0}$	$fe_{0,0}$	$ff_{0,0}$	$fg_{0,0}$	$fh_{0,0}$	$fa_{1,0}$
$gh_{-1,0}$	$ga_{0,0}$	$gb_{0,0}$	$gc_{0,0}$	$gd_{0,0}$	$ge_{0,0}$	$gf_{0,0}$	$gg_{0,0}$	$gh_{0,0}$	$ga_{1,0}$
$hh_{-1,0}$	$ha_{0,0}$	$hb_{0,0}$	$hc_{0,0}$	$hd_{0,0}$	$he_{0,0}$	$hf_{0,0}$	$hg_{0,0}$	$hh_{0,0}$	$ha_{1,0}$
	$B_{0,1}$	$ab_{0,1}$	$ac_{0,1}$	$ad_{0,1}$	$ae_{0,1}$	$af_{0,1}$	$ag_{0,1}$	$ah_{0,1}$	$B_{1,1}$

Figure 8-5 — Integer samples (shaded blocks with upper-case letters) and fractional sample positions (un-shaded blocks with lower-case letters) for eighth sample chroma interpolation

In Figure 8-5, the positions labelled with upper-case letters $B_{i,j}$ within shaded blocks represent chroma samples at full-sample locations inside the given two-dimensional array $refPicLX_c$ of chroma samples. These samples may be used for generating the predicted chroma sample value $predSampleLX_c$. The locations $(x_{B_{i,j}}, y_{B_{i,j}})$ for each of the corresponding chroma samples $B_{i,j}$ inside the given array $refPicLX_c$ of chroma samples are derived as follows:

$$x_{B_{i,j}} = \text{Clip3}(0, (\text{pic_width_in_luma_samples} / \text{SubWidthC}) - 1, xInt_c + i) \tag{8-241}$$

$$y_{B_{i,j}} = \text{Clip3}(0, (\text{pic_height_in_luma_samples} / \text{SubHeightC}) - 1, yInt_c + j) \tag{8-242}$$

The positions labelled with lower-case letters within un-shaded blocks represent chroma samples at eighth-pel sample fractional locations. The chroma location offset in fractional-sample units $(xFrac_c, yFrac_c)$ specifies which of the generated chroma samples at full-sample and fractional-sample locations is assigned to the predicted chroma sample value $predSampleLX_c$. This assignment is as specified in Table 8-9. The output is the value of $predSampleLX_c$.

ISO/IEC 23008-2:2017(E)

The variables shift1, shift2, and shift3 are derived as follows:

- The variable shift1 is set equal to $\text{Min}(4, \text{BitDepth}_c - 8)$, the variable shift2 is set equal to 6, and the variable shift3 is set equal to $\text{Max}(2, 14 - \text{BitDepth}_c)$.

Given the chroma samples $B_{i,j}$ at full-sample locations $(x_{B_{i,j}}, y_{B_{i,j}})$, the chroma samples $ab_{0,0}$ to $hh_{0,0}$ at fractional sample positions are derived as follows:

- The samples labelled $ab_{0,0}$, $ac_{0,0}$, $ad_{0,0}$, $ae_{0,0}$, $af_{0,0}$, $ag_{0,0}$, and $ah_{0,0}$ are derived by applying a 4-tap filter to the nearest integer position samples as follows:

$$ab_{0,0} = (-2 * B_{-1,0} + 58 * B_{0,0} + 10 * B_{1,0} - 2 * B_{2,0}) \gg \text{shift1} \quad (8-243)$$

$$ac_{0,0} = (-4 * B_{-1,0} + 54 * B_{0,0} + 16 * B_{1,0} - 2 * B_{2,0}) \gg \text{shift1} \quad (8-244)$$

$$ad_{0,0} = (-6 * B_{-1,0} + 46 * B_{0,0} + 28 * B_{1,0} - 4 * B_{2,0}) \gg \text{shift1} \quad (8-245)$$

$$ae_{0,0} = (-4 * B_{-1,0} + 36 * B_{0,0} + 36 * B_{1,0} - 4 * B_{2,0}) \gg \text{shift1} \quad (8-246)$$

$$af_{0,0} = (-4 * B_{-1,0} + 28 * B_{0,0} + 46 * B_{1,0} - 6 * B_{2,0}) \gg \text{shift1} \quad (8-247)$$

$$ag_{0,0} = (-2 * B_{-1,0} + 16 * B_{0,0} + 54 * B_{1,0} - 4 * B_{2,0}) \gg \text{shift1} \quad (8-248)$$

$$ah_{0,0} = (-2 * B_{-1,0} + 10 * B_{0,0} + 58 * B_{1,0} - 2 * B_{2,0}) \gg \text{shift1} \quad (8-249)$$

- The samples labelled $ba_{0,0}$, $ca_{0,0}$, $da_{0,0}$, $ea_{0,0}$, $fa_{0,0}$, $ga_{0,0}$, and $ha_{0,0}$ are derived by applying a 4-tap filter to the nearest integer position samples as follows:

$$ba_{0,0} = (-2 * B_{0,-1} + 58 * B_{0,0} + 10 * B_{0,1} - 2 * B_{0,2}) \gg \text{shift1} \quad (8-250)$$

$$ca_{0,0} = (-4 * B_{0,-1} + 54 * B_{0,0} + 16 * B_{0,1} - 2 * B_{0,2}) \gg \text{shift1} \quad (8-251)$$

$$da_{0,0} = (-6 * B_{0,-1} + 46 * B_{0,0} + 28 * B_{0,1} - 4 * B_{0,2}) \gg \text{shift1} \quad (8-252)$$

$$ea_{0,0} = (-4 * B_{0,-1} + 36 * B_{0,0} + 36 * B_{0,1} - 4 * B_{0,2}) \gg \text{shift1} \quad (8-253)$$

$$fa_{0,0} = (-4 * B_{0,-1} + 28 * B_{0,0} + 46 * B_{0,1} - 6 * B_{0,2}) \gg \text{shift1} \quad (8-254)$$

$$ga_{0,0} = (-2 * B_{0,-1} + 16 * B_{0,0} + 54 * B_{0,1} - 4 * B_{0,2}) \gg \text{shift1} \quad (8-255)$$

$$ha_{0,0} = (-2 * B_{0,-1} + 10 * B_{0,0} + 58 * B_{0,1} - 2 * B_{0,2}) \gg \text{shift1} \quad (8-256)$$

- The samples labelled $bX_{0,0}$, $cX_{0,0}$, $dX_{0,0}$, $eX_{0,0}$, $fX_{0,0}$, $gX_{0,0}$, and $hX_{0,0}$ for X being replaced by b, c, d, e, f, g, and h, respectively, are derived by applying a 4-tap filter to the intermediate values $aX_{0,i}$ with $i = -1..2$ in the vertical direction as follows:

$$bX_{0,0} = (-2 * aX_{0,-1} + 58 * aX_{0,0} + 10 * aX_{0,1} - 2 * aX_{0,2}) \gg \text{shift2} \quad (8-257)$$

$$cX_{0,0} = (-4 * aX_{0,-1} + 54 * aX_{0,0} + 16 * aX_{0,1} - 2 * aX_{0,2}) \gg \text{shift2} \quad (8-258)$$

$$dX_{0,0} = (-6 * aX_{0,-1} + 46 * aX_{0,0} + 28 * aX_{0,1} - 4 * aX_{0,2}) \gg \text{shift2} \quad (8-259)$$

$$eX_{0,0} = (-4 * aX_{0,-1} + 36 * aX_{0,0} + 36 * aX_{0,1} - 4 * aX_{0,2}) \gg \text{shift2} \quad (8-260)$$

$$fX_{0,0} = (-4 * aX_{0,-1} + 28 * aX_{0,0} + 46 * aX_{0,1} - 6 * aX_{0,2}) \gg \text{shift2} \quad (8-261)$$

$$gX_{0,0} = (-2 * aX_{0,-1} + 16 * aX_{0,0} + 54 * aX_{0,1} - 4 * aX_{0,2}) \gg \text{shift2} \quad (8-262)$$

$$hX_{0,0} = (-2 * aX_{0,-1} + 10 * aX_{0,0} + 58 * aX_{0,1} - 2 * aX_{0,2}) \gg \text{shift2} \quad (8-263)$$

Table 8-9 — Assignment of the chroma prediction sample predSampleLXc for (X, Y) being replaced by (1, b), (2, c), (3, d), (4, e), (5, f), (6, g), and (7, h), respectively

xFracC	0	0	0	0	0	0	0	0
yFracC	0	1	2	3	4	5	6	7
predSampleLXc	B << shift3	ba	ca	da	ea	fa	ga	ha
xFracC	X	X	X	X	X	X	X	X
yFracC	0	1	2	3	4	5	6	7
predSampleLXc	aY	bY	cY	dY	eY	fY	gY	hY

8.5.3.3.4 Weighted sample prediction process

8.5.3.3.4.1 General

Inputs to this process are

- two variables nPbW and nPbH specifying the width and the height of the current prediction block,
- two (nPbW)x(nPbH) arrays predSamplesL0 and predSamplesL1,
- the prediction list utilization flags, predFlagL0, and predFlagL1,
- the reference indices refIdxL0 and refIdxL1, and
- a variable cIdx specifying colour component index.

Output of this process is the (nPbW)x(nPbH) array pbSamples of prediction sample values.

The variable bitDepth is derived as follows:

- If cIdx is equal to 0, bitDepth is set equal to BitDepth_Y.
- Otherwise, bitDepth is set equal to BitDepth_C.

The variable weightedPredFlag is derived as follows:

- If slice_type is equal to P, weightedPredFlag is set equal to weighted_pred_flag.
- Otherwise (slice_type is equal to B), weightedPredFlag is set equal to weighted_bipred_flag.

The following apply:

- If weightedPredFlag is equal to 0, the array pbSamples of the prediction samples is derived by invoking the default weighted sample prediction process as specified in 8.5.3.3.4.2 with the prediction block width nPbW, the prediction block height nPbH, two (nPbW)x(nPbH) arrays predSamplesL0 and predSamplesL1, the prediction list utilization flags predFlagL0 and predFlagL1, and the bit depth bitDepth as inputs.
- Otherwise (weightedPredFlag is equal to 1), the array pbSamples of the prediction samples is derived by invoking the weighted sample prediction process as specified in 8.5.3.3.4.3 with the prediction block width nPbW, the prediction block height nPbH, two (nPbW)x(nPbH) arrays predSamplesL0 and predSamplesL1, the prediction list utilization flags predFlagL0 and predFlagL1, the reference indices refIdxL0 and refIdxL1, the colour component index cIdx, and the bit depth bitDepth as inputs.

ISO/IEC 23008-2:2017(E)

8.5.3.3.4.2 Default weighted sample prediction process

Inputs to this process are

- two variables nPbW and nPbH specifying the width and the height of the current prediction block,
- two (nPbW)x(nPbH) arrays predSamplesL0 and predSamplesL1,
- the prediction list utilization flags, predFlagL0, and predFlagL1, and
- a bit depth of samples, bitDepth.

Output of this process is the (nPbW)x(nPbH) array pbSamples of prediction sample values.

Variables shift1, shift2, offset1, and offset2 are derived as follows:

- The variable shift1 is set equal to $\text{Max}(2, 14 - \text{bitDepth})$ and the variable shift2 is set equal to $\text{Max}(3, 15 - \text{bitDepth})$.
- The variable offset1 is set equal to $1 \ll (\text{shift1} - 1)$.
- The variable offset2 is set equal to $1 \ll (\text{shift2} - 1)$.

Depending on the values of predFlagL0 and predFlagL1, the prediction samples pbSamples[x][y] with $x = 0..nPbW - 1$ and $y = 0..nPbH - 1$ are derived as follows:

- If predFlagL0 is equal to 1 and predFlagL1 is equal to 0, the prediction sample values are derived as follows:

$$\text{pbSamples}[x][y] = \text{Clip3}(0, (1 \ll \text{bitDepth}) - 1, (\text{predSamplesL0}[x][y] + \text{offset1}) \gg \text{shift1}) \quad (8-264)$$

- Otherwise, if predFlagL0 is equal to 0 and predFlagL1 is equal to 1, the prediction sample values are derived as follows:

$$\text{pbSamples}[x][y] = \text{Clip3}(0, (1 \ll \text{bitDepth}) - 1, (\text{predSamplesL1}[x][y] + \text{offset1}) \gg \text{shift1}) \quad (8-265)$$

- Otherwise (predFlagL0 is equal to 1 and predFlagL1 is equal to 1), the prediction sample values are derived as follows:

$$\text{pbSamples}[x][y] = \text{Clip3}(0, (1 \ll \text{bitDepth}) - 1, (\text{predSamplesL0}[x][y] + \text{predSamplesL1}[x][y] + \text{offset2}) \gg \text{shift2}) \quad (8-266)$$

8.5.3.3.4.3 Explicit weighted sample prediction process

Inputs to this process are

- two variables nPbW and nPbH specifying the width and the height of the current prediction block,
- two (nPbW)x(nPbH) arrays predSamplesL0 and predSamplesL1,
- the prediction list utilization flags, predFlagL0, and predFlagL1,
- the reference indices, refIdxL0 and refIdxL1,
- a variable cIdx specifying colour component index, and
- a bit depth of samples, bitDepth.

Output of this process is the $(nPbW) \times (nPbH)$ array `pbSamples` of prediction sample values.

The variable `shift1` is set equal to $\text{Max}(2, 14 - \text{bitDepth})$.

The variables `log2Wd`, `o0`, `o1`, and `w0`, `w1` are derived as follows.

— If `cIdx` is equal to 0 for luma samples, the following apply:

$$\text{log2Wd} = \text{luma_log2_weight_denom} + \text{shift1} \quad (8-267)$$

$$w0 = \text{LumaWeightL0}[\text{refIdxL0}] \quad (8-268)$$

$$w1 = \text{LumaWeightL1}[\text{refIdxL1}] \quad (8-269)$$

$$o0 = \text{luma_offset_l0}[\text{refIdxL0}] \ll \text{WpOffsetBdShift}_y \quad (8-270)$$

$$o1 = \text{luma_offset_l1}[\text{refIdxL1}] \ll \text{WpOffsetBdShift}_y \quad (8-271)$$

— Otherwise (`cIdx` is not equal to 0 for chroma samples), the following apply:

$$\text{log2Wd} = \text{ChromaLog2WeightDenom} + \text{shift1} \quad (8-272)$$

$$w0 = \text{ChromaWeightL0}[\text{refIdxL0}][\text{cIdx} - 1] \quad (8-273)$$

$$w1 = \text{ChromaWeightL1}[\text{refIdxL1}][\text{cIdx} - 1] \quad (8-274)$$

$$o0 = \text{ChromaOffsetL0}[\text{refIdxL0}][\text{cIdx} - 1] \ll \text{WpOffsetBdShift}_c \quad (8-275)$$

$$o1 = \text{ChromaOffsetL1}[\text{refIdxL1}][\text{cIdx} - 1] \ll \text{WpOffsetBdShift}_c \quad (8-276)$$

The prediction sample `pbSamples[x][y]` with $x = 0..nPbW - 1$ and $y = 0..nPbH - 1$ are derived as follows:

— If the `predFlagL0` is equal to 1 and `predFlagL1` is equal to 0, the prediction sample values are derived as follows:

$$\begin{aligned} &\text{if}(\text{log2Wd} \geq 1) \\ &\quad \text{pbSamples}[x][y] = \text{Clip3}(0, (1 \ll \text{bitDepth}) - 1, \\ &\quad \quad ((\text{predSamplesL0}[x][y] * w0 + 2^{\text{log2Wd} - 1}) \gg \text{log2Wd}) + o0) \\ &\text{else} \\ &\quad \text{pbSamples}[x][y] = \text{Clip3}(0, (1 \ll \text{bitDepth}) - 1, \text{predSamplesL0}[x][y] * w0 + o0) \end{aligned} \quad (8-277)$$

— Otherwise, if the `predFlagL0` is equal to 0 and `predFlagL1` is equal to 1, the prediction sample values are derived as follows:

$$\begin{aligned} &\text{if}(\text{log2Wd} \geq 1) \\ &\quad \text{pbSamples}[x][y] = \text{Clip3}(0, (1 \ll \text{bitDepth}) - 1, \\ &\quad \quad ((\text{predSamplesL1}[x][y] * w1 + 2^{\text{log2Wd} - 1}) \gg \text{log2Wd}) + o1) \\ &\text{else} \\ &\quad \text{pbSamples}[x][y] = \text{Clip3}(0, (1 \ll \text{bitDepth}) - 1, \text{predSamplesL1}[x][y] * w1 + o1) \end{aligned} \quad (8-278)$$

— Otherwise (`predFlagL0` is equal to 1 and `predFlagL1` is equal to 1), the prediction sample values are derived as follows:

$$\begin{aligned} \text{pbSamples}[x][y] = &\text{Clip3}(0, (1 \ll \text{bitDepth}) - 1, \\ &((\text{predSamplesL0}[x][y] * w0 + \text{predSamplesL1}[x][y] * w1 + \\ &\quad ((o0 + o1 + 1) \ll \text{log2Wd})) \gg (\text{log2Wd} + 1)) \end{aligned} \quad (8-279)$$

8.5.4 Decoding process for the residual signal of coding units coded in inter prediction mode

8.5.4.1 General

Inputs to this process are

- a luma location (x_{Cb}, y_{Cb}) specifying the top-left sample of the current luma coding block relative to the top-left luma sample of the current picture, and
- a variable $\log_2 CbSize$ specifying the size of the current luma coding block.

Outputs of this process are

- an $(nCbS_L) \times (nCbS_L)$ array $resSamples_L$ of luma residual samples, where $nCbS_L$ is derived as specified below,
- when $ChromaArrayType$ is not equal to 0, an $(nCbSw_C) \times (nCbSh_C)$ array $resSamples_{Cb}$ of chroma residual samples for the component Cb, where $nCbSw_C$ and $nCbSh_C$ are derived as specified below,
- when $ChromaArrayType$ is not equal to 0, an $(nCbSw_C) \times (nCbSh_C)$ array $resSamples_{Cr}$ of chroma residual samples for the component Cr, where $nCbSw_C$ and $nCbSh_C$ are derived as specified below.

The variable $nCbS_L$ is set equal to $1 \ll \log_2 CbSize$. When $ChromaArrayType$ is not equal to 0, the variable $nCbSw_C$ is set equal to $nCbS_L / SubWidthC$ and the variable $nCbSh_C$ is set equal to $nCbS_L / SubHeightC$.

Let $resSamples_L$ be an $(nCbS_L) \times (nCbS_L)$ array of luma residual samples and, when $ChromaArrayType$ is not equal to 0, let $resSamples_{Cb}$ and $resSamples_{Cr}$ be two $(nCbSw_C) \times (nCbSh_C)$ arrays of chroma residual samples.

Depending on the value of rqt_root_cbf , the following apply:

- If rqt_root_cbf is equal to 0 or $cu_skip_flag[xCb][yCb]$ is equal to 1, all samples of the $(nCbS_L) \times (nCbS_L)$ array $resSamples_L$ and, when $ChromaArrayType$ is not equal to 0, all samples of the two $(nCbSw_C) \times (nCbSh_C)$ arrays $resSamples_{Cb}$ and $resSamples_{Cr}$ are set equal to 0.
- Otherwise (rqt_root_cbf is equal to 1), the following ordered steps apply:
 1. The decoding process for luma residual blocks as specified in 8.5.4.2 below is invoked with the luma location (x_{Cb}, y_{Cb}), the luma location (x_{B0}, y_{B0}) set equal to (0, 0), the variable $\log_2 TrafoSize$ set equal to $\log_2 CbSize$, the variable $trafoDepth$ set equal to 0, the variable $nCbS$ set equal to $nCbS_L$, and the $(nCbS_L) \times (nCbS_L)$ array $resSamples_L$ as inputs, and the output is a modified version of the $(nCbS_L) \times (nCbS_L)$ array $resSamples_L$.
 2. When $ChromaArrayType$ is not equal to 0, the decoding process for chroma residual blocks as specified in 8.5.4.3 is invoked with the luma location (x_{Cb}, y_{Cb}), the luma location (x_{B0}, y_{B0}) set equal to (0, 0), the variable $\log_2 TrafoSize$ set equal to $\log_2 CbSize$, the variable $trafoDepth$ set equal to 0, the variable $cIdx$ set equal to 1, the variable $nCbSw$ set equal to $nCbSw_C$, the variable $nCbSh$ set equal to $nCbSh_C$, and the $(nCbSw_C) \times (nCbSh_C)$ array $resSamples_{Cb}$ as inputs, and the output is a modified version of the $(nCbSw_C) \times (nCbSh_C)$ array $resSamples_{Cb}$.
 3. When $ChromaArrayType$ is not equal to 0, the decoding process for chroma residual blocks as specified in 8.5.4.3 is invoked with the luma location (x_{Cb}, y_{Cb}), the luma location (x_{B0}, y_{B0}) set equal to (0, 0), the variable $\log_2 TrafoSize$ set equal to $\log_2 CbSize$, the variable $trafoDepth$ set equal to 0, the variable $cIdx$ set equal to 2, the variable $nCbSw$ set equal to $nCbSw_C$, the variable $nCbSh$ set equal to $nCbSh_C$, and the $(nCbSw_C) \times (nCbSh_C)$ array $resSamples_{Cr}$ as inputs, and the output is a modified version of the $(nCbSw_C) \times (nCbSh_C)$ array $resSamples_{Cr}$.

4. When `residual_adaptive_colour_transform_enabled_flag` is equal to 1, the residual modification process for blocks using adaptive colour transform as specified in 8.6.8 is invoked with location (x_{Cb}, y_{Cb}) , the variable `log2TrafoSize` set equal to `log2CbSize`, the variable `trafoDepth` set equal to 0, the variable `resSampleArrayL` set equal to `resSamplesL`, the variable `resSampleArrayCb` set equal to `resSamplesCb` and the variable `resSampleArrayCr` set equal to `resSamplesCr` as inputs, and the outputs are modified versions of `resSampleL`, `resSampleCb` and `resSampleCr`.

8.5.4.2 Decoding process for luma residual blocks

Inputs to this process are

- a luma location (x_{Cb}, y_{Cb}) specifying the top-left sample of the current luma coding block relative to the top-left luma sample of the current picture,
- a luma location (x_{B0}, y_{B0}) specifying the top-left sample of the current luma block relative to the top-left sample of the current luma coding block,
- a variable `log2TrafoSize` specifying the size of the current luma block,
- a variable `trafoDepth` specifying the hierarchy depth of the current luma block relative to the luma coding block,
- a variable `nCbS` specifying the size of the current luma coding block, and
- an $(nCbS) \times (nCbS)$ array `resSamples` of luma residual samples.

Output of this process is a modified version of the $(nCbS) \times (nCbS)$ array of luma residual samples.

Depending on the value of `split_transform_flag[xCb + xB0][yCb + yB0][trafoDepth]`, the following apply:

- If `split_transform_flag[xCb + xB0][yCb + yB0][trafoDepth]` is equal to 1, the following ordered steps apply:
 1. The variables `xB1` and `yB1` are derived as follows:
 - The variable `xB1` is set equal to $x_{B0} + (1 \ll (\log_2 \text{TrafoSize} - 1))$.
 - The variable `yB1` is set equal to $y_{B0} + (1 \ll (\log_2 \text{TrafoSize} - 1))$.
 2. The decoding process for luma residual blocks as specified in this subclause is invoked with the luma location (x_{Cb}, y_{Cb}) , the luma location (x_{B0}, y_{B0}) , the variable `log2TrafoSize` set equal to `log2TrafoSize - 1`, the variable `trafoDepth` set equal to `trafoDepth + 1`, the variable `nCbS`, and the $(nCbS) \times (nCbS)$ array `resSamples` as inputs, and the output is a modified version of the $(nCbS) \times (nCbS)$ array `resSamples`.
 3. The decoding process for luma residual blocks as specified in this subclause is invoked with the luma location (x_{Cb}, y_{Cb}) , the luma location (x_{B1}, y_{B0}) , the variable `log2TrafoSize` set equal to `log2TrafoSize - 1`, the variable `trafoDepth` set equal to `trafoDepth + 1`, the variable `nCbS`, and the $(nCbS) \times (nCbS)$ array `resSamples` as inputs, and the output is a modified version of the $(nCbS) \times (nCbS)$ array `resSamples`.
 4. The decoding process for luma residual blocks as specified in this subclause is invoked with the luma location (x_{Cb}, y_{Cb}) , the luma location (x_{B0}, y_{B1}) , the variable `log2TrafoSize` set equal to `log2TrafoSize - 1`, the variable `trafoDepth` set equal to `trafoDepth + 1`, the variable `nCbS`, and the $(nCbS) \times (nCbS)$ array `resSamples` as inputs, and the output is a modified version of the $(nCbS) \times (nCbS)$ array `resSamples`.

ISO/IEC 23008-2:2017(E)

5. The decoding process for luma residual blocks as specified in this subclause is invoked with the luma location (x_{Cb} , y_{Cb}), the luma location (x_{B1} , y_{B1}), the variable $\log_2\text{TrafoSize}$ set equal to $\log_2\text{TrafoSize} - 1$, the variable trafoDepth set equal to $\text{trafoDepth} + 1$, the variable n_{CbS} , and the $(n_{CbS}) \times (n_{CbS})$ array resSamples as inputs, and the output is a modified version of the $(n_{CbS}) \times (n_{CbS})$ array resSamples .
- Otherwise ($\text{split_transform_flag}[x_{Cb} + x_{B0}][y_{Cb} + y_{B0}][\text{trafoDepth}]$ is equal to 0), the following ordered steps apply:
1. The variable n_{TbS} is set equal to $1 \ll \log_2\text{TrafoSize}$.
 2. The scaling and transformation process as specified in 8.6.2 is invoked with the luma location ($x_{Cb} + x_{B0}$, $y_{Cb} + y_{B0}$), the variable trafoDepth , the variable cIdx set equal to 0, and the transform size trafoSize set equal to n_{TbS} as inputs, and the output is an $(n_{TbS}) \times (n_{TbS})$ array transformBlock .
 3. When $\text{explicit_rdpcm_flag}[x_{Cb} + x_{B0}][y_{Cb} + y_{B0}][0]$ is equal to 1, the directional residual modification process for blocks using a transform bypass as specified in 8.6.5 is invoked with the variable mDir set equal to $\text{explicit_rdpcm_dir_flag}[x_{Cb} + x_{B0}][y_{Cb} + y_{B0}][0]$, the variable n_{TbS} , and the $(n_{TbS}) \times (n_{TbS})$ array r set equal to the array transformBlock as inputs, and the output is a modified $(n_{TbS}) \times (n_{TbS})$ array transformBlock .
 4. The $(n_{CbS}) \times (n_{CbS})$ residual sample array of the current coding block resSamples is modified as follows:

$$\text{resSamples}[x_{B0} + i, y_{B0} + j] = \text{transformBlock}[i, j], \text{ with } i = 0..n_{TbS} - 1, j = 0..n_{TbS} - 1 \quad (8-280)$$

8.5.4.3 Decoding process for chroma residual blocks

This process is only invoked when ChromaArrayType is not equal to 0.

Inputs to this process are

- a luma location (x_{Cb} , y_{Cb}) specifying the top-left sample of the current luma coding block relative to the top-left luma sample of the current picture,
- a luma location (x_{B0} , y_{B0}) specifying the top-left luma sample of the current chroma block relative to the top-left sample of the current luma coding block,
- a variable $\log_2\text{TrafoSize}$ specifying the size of the current chroma block in luma samples,
- a variable trafoDepth specifying the hierarchy depth of the current chroma block relative to the chroma coding block,
- a variable cIdx specifying the chroma component of the current block,
- the variables n_{CbSw} and n_{CbSh} specifying the width and height, respectively, of the current chroma coding block, and
- an $(n_{CbSw}) \times (n_{CbSh})$ array resSamples of chroma residual samples.

Output of this process is a modified version of the $(n_{CbSw}) \times (n_{CbSh})$ array of chroma residual samples.

The variable splitChromaFlag is derived as follows:

- If $\text{split_transform_flag}[x_{Cb} + x_{B0}][y_{Cb} + y_{B0}][\text{trafoDepth}]$ is equal to 1 and one or more of the following conditions are met, splitChromaFlag is set equal to 1:

- $\log_2\text{TrafoSize}$ is greater than 3.
- ChromaArrayType is equal to 3.
- Otherwise ($\text{split_transform_flag}[\text{xCb} + \text{xB0}][\text{yCb} + \text{yB0}][\text{trafoDepth}]$ is equal to 0 or both $\log_2\text{TrafoSize}$ is equal to 3 and ChromaArrayType is not equal to 3), splitChromaFlag is set equal to 0.

Depending on the value of splitChromaFlag , the following apply:

- If splitChromaFlag is equal to 1, the following ordered steps apply:
 1. The variables xB1 and yB1 are derived as follows:
 - The variable xB1 is set equal to $\text{xB0} + (1 \ll (\log_2\text{TrafoSize} - 1))$.
 - The variable yB1 is set equal to $\text{yB0} + (1 \ll (\log_2\text{TrafoSize} - 1))$.
 2. The decoding process for residual chroma blocks as specified in this subclause is invoked with the luma location (xCb, yCb) , the luma location $(\text{xB0}, \text{yB0})$, the variable $\log_2\text{TrafoSize}$ set equal to $\log_2\text{TrafoSize} - 1$, the variable trafoDepth set equal to $\text{trafoDepth} + 1$, the variable cIdx , the variable nCbSw , the variable nCbSh , and the $(\text{nCbSw}) \times (\text{nCbSh})$ array resSamples as inputs, and the output is a modified version of the $(\text{nCbSw}) \times (\text{nCbSh})$ array resSamples .
 3. The decoding process for residual chroma blocks as specified in this subclause is invoked with the luma location (xCb, yCb) , the luma location $(\text{xB1}, \text{yB0})$, the variable $\log_2\text{TrafoSize}$ set equal to $\log_2\text{TrafoSize} - 1$, the variable trafoDepth set equal to $\text{trafoDepth} + 1$, the variable cIdx , the variable nCbSw , the variable nCbSh , and the $(\text{nCbSw}) \times (\text{nCbSh})$ array resSamples as inputs, and the output is a modified version of the $(\text{nCbSw}) \times (\text{nCbSh})$ array resSamples .
 4. The decoding process for residual chroma blocks as specified in this subclause is invoked with the luma location (xCb, yCb) , the luma location $(\text{xB0}, \text{yB1})$, the variable $\log_2\text{TrafoSize}$ set equal to $\log_2\text{TrafoSize} - 1$, the variable trafoDepth set equal to $\text{trafoDepth} + 1$, the variable cIdx , the variable nCbSw , the variable nCbSh , and the $(\text{nCbSw}) \times (\text{nCbSh})$ array resSamples as inputs, and the output is a modified version of the $(\text{nCbSw}) \times (\text{nCbSh})$ array resSamples .
 5. The decoding process for residual chroma blocks as specified in this subclause is invoked with the luma location (xCb, yCb) , the luma location $(\text{xB1}, \text{yB1})$, the variable $\log_2\text{TrafoSize}$ set equal to $\log_2\text{TrafoSize} - 1$, the variable trafoDepth set equal to $\text{trafoDepth} + 1$, the variable cIdx , the variable nCbSw , the variable nCbSh , and the $(\text{nCbSw}) \times (\text{nCbSh})$ array resSamples as inputs, and the output is a modified version of the $(\text{nCbSw}) \times (\text{nCbSh})$ array resSamples .
- Otherwise (splitChromaFlag is equal to 0), for the variable blkIdx proceeding over the values $0 \dots (\text{ChromaArrayType} = 2 ? 1 : 0)$, the following ordered steps apply:
 1. The variable nTbS is set equal to $(1 \ll \log_2\text{TrafoSize}) / \text{SubWidthC}$.
 2. The variable yBN is set equal to $\text{yB0} + \text{blkIdx} * \text{nTbS} * \text{SubHeightC}$.
 3. The scaling and transformation process as specified in 8.6.2 is invoked with the luma location $(\text{xCb} + \text{xB0}, \text{yCb} + \text{yBN})$, the variable trafoDepth , the variable cIdx , and the transform size trafoSize set equal to nTbS as inputs, and the output is an $(\text{nTbS}) \times (\text{nTbS})$ array transformBlock .
 4. When $\text{explicit_rdpcm_flag}[\text{xCb} + \text{xB0}][\text{yCb} + \text{yBN}][\text{cIdx}]$ is equal to 1, the directional residual modification process for blocks using a transform bypass as specified in 8.6.5 is invoked with

the variable $mDir$ set equal to $explicit_rdpcm_dir_flag[xCb + xB0][yCb + yBN][cIdx]$, the variable $nTbS$, and the $(nTbS) \times (nTbS)$ array r set equal to the array $transformBlock$ as inputs, and the output is a modified $(nTbS) \times (nTbS)$ array $transformBlock$.

5. When $cross_component_prediction_enabled_flag$ is equal to 1 and $ChromaArrayType$ is equal to 3, the residual modification process for transform blocks using cross-component prediction as specified in 8.6.6 is invoked with the transform block location $(xCb + xB0, yCb + yB0)$, the variable $nTbS$, the variable $cIdx$, the $(nTbS) \times (nTbS)$ array r_Y set equal to the corresponding luma residual sample array $transformBlock$ of the current transform block, and the $(nTbS) \times (nTbS)$ array r set equal to the array $transformBlock$ as inputs, and the output is a modified $(nTbS) \times (nTbS)$ array $resSamples$.
6. The $(nCbs) \times (nCbs)$ residual sample array of the current coding block $resSamples$ is modified as follows, for $i = 0..nTbS - 1, j = 0..nTbS - 1$:

$$resSamples[(xCb + xB0) / SubWidthC + i, (yCb + yBN) / SubHeightC + j] = transformBlock[i, j] \quad (8-281)$$

8.6 Scaling, transformation and array construction process prior to deblocking filter process

8.6.1 Derivation process for quantization parameters

Input to this process is a luma location (xCb, yCb) specifying the top-left sample of the current luma coding block relative to the top-left luma sample of the current picture.

In this process, the variable Qp_Y , the luma quantization parameter Qp'_Y , and the chroma quantization parameters Qp'_{Cb} and Qp'_{Cr} are derived.

The luma location (xQg, yQg) , specifies the top-left luma sample of the current quantization group relative to the top-left luma sample of the current picture. The horizontal and vertical positions xQg and yQg are set equal to $xCb - (xCb \& ((1 \ll \text{Log2MinCuQpDeltaSize}) - 1))$ and $yCb - (yCb \& ((1 \ll \text{Log2MinCuQpDeltaSize}) - 1))$, respectively. The luma size of a quantization group, $\text{Log2MinCuQpDeltaSize}$, determines the luma size of the smallest area inside a coding tree block that shares the same qP_{Y_PRED} .

The predicted luma quantization parameter qP_{Y_PRED} is derived by the following ordered steps:

1. The variable qP_{Y_PREV} is derived as follows:
 - If one or more of the following conditions are true, qP_{Y_PREV} is set equal to SliceQp_Y :
 - The current quantization group is the first quantization group in a slice.
 - The current quantization group is the first quantization group in a tile.
 - The current quantization group is the first quantization group in a coding tree block row of a tile and $entropy_coding_sync_enabled_flag$ is equal to 1.
 - Otherwise, qP_{Y_PREV} is set equal to the luma quantization parameter Qp_Y of the last coding unit in the previous quantization group in decoding order.
2. The availability derivation process for a block in z-scan order as specified in 6.4.1 is invoked with the location $(xCurr, yCurr)$ set equal to (xCb, yCb) and the neighbouring location $(xNbY, yNbY)$ set equal to $(xQg - 1, yQg)$ as inputs, and the output is assigned to $availableA$. The variable qP_{Y_A} is derived as follows:
 - If one or more of the following conditions are true, qP_{Y_A} is set equal to qP_{Y_PREV} :

- availableA is equal to FALSE;
- the coding tree block address ctbAddrA of the coding tree block containing the luma coding block covering the luma location (xQg - 1, yQg) is not equal to CtbAddrInTs, where ctbAddrA is derived as follows:

$$\begin{aligned} xTmp &= (xQg - 1) \gg \text{MinTbLog2SizeY} \\ yTmp &= yQg \gg \text{MinTbLog2SizeY} \\ \text{minTbAddrA} &= \text{MinTbAddrZs}[xTmp][yTmp] \\ \text{ctbAddrA} &= \text{minTbAddrA} \gg (2 * (\text{CtbLog2SizeY} - \text{MinTbLog2SizeY})) \end{aligned} \quad (8-282)$$

- Otherwise, $qP_{Y,A}$ is set equal to the luma quantization parameter Qp_Y of the coding unit containing the luma coding block covering (xQg - 1, yQg).

3. The availability derivation process for a block in z-scan order as specified in 6.4.1 is invoked with the location (xCurr, yCurr) set equal to (xCb, yCb) and the neighbouring location (xNbY, yNbY) set equal to (xQg, yQg - 1) as inputs, and the output is assigned to availableB. The variable $qP_{Y,B}$ is derived as follows:

- If one or more of the following conditions are true, $qP_{Y,B}$ is set equal to $qP_{Y,PREV}$:

- availableB is equal to FALSE;
- the coding tree block address ctbAddrB of the coding tree block containing the luma coding block covering the luma location (xQg, yQg - 1) is not equal to CtbAddrInTs, where ctbAddrB is derived as follows:

$$\begin{aligned} xTmp &= xQg \gg \text{MinTbLog2SizeY} \\ yTmp &= (yQg - 1) \gg \text{MinTbLog2SizeY} \\ \text{minTbAddrB} &= \text{MinTbAddrZs}[xTmp][yTmp] \\ \text{ctbAddrB} &= \text{minTbAddrB} \gg (2 * (\text{CtbLog2SizeY} - \text{MinTbLog2SizeY})) \end{aligned} \quad (8-283)$$

- Otherwise, $qP_{Y,B}$ is set equal to the luma quantization parameter Qp_Y of the coding unit containing the luma coding block covering (xQg, yQg - 1).

4. The predicted luma quantization parameter $qP_{Y,PRED}$ is derived as follows:

$$qP_{Y,PRED} = (qP_{Y,A} + qP_{Y,B} + 1) \gg 1 \quad (8-284)$$

The variable Qp_Y is derived as follows:

$$Qp_Y = ((qP_{Y,PRED} + \text{CuQpDeltaVal} + 52 + 2 * \text{QpBdOffset}_Y) \% (52 + \text{QpBdOffset}_Y)) - \text{QpBdOffset}_Y \quad (8-285)$$

The luma quantization parameter Qp'_Y is derived as follows:

$$Qp'_Y = Qp_Y + \text{QpBdOffset}_Y \quad (8-286)$$

When ChromaArrayType is not equal to 0, the following apply:

- The variables qP_{Cb} and qP_{Cr} are derived as follows:

- If $\text{tu_residual_act_flag}[xTbY][yTbY]$ is equal to 0, the following apply:

$$qP_{iCb} = \text{Clip3}(-\text{QpBdOffset}_C, 57, Qp_Y + \text{pps_cb_qp_offset} + \text{slice_cb_qp_offset} + \text{CuQpOffset}_{Cb}) \quad (8-287)$$

$$qP_{iCr} = \text{Clip3}(-\text{QpBdOffset}_C, 57, Qp_Y + \text{pps_cr_qp_offset} + \text{slice_cr_qp_offset} + \text{CuQpOffset}_{Cr}) \quad (8-288)$$

— Otherwise ($tu_residual_act_flag[xTbY][yTbY]$ is equal to 1), the following apply:

$$qP_{Cb} = Clip3(-QpBdOffsetC, 57, QpY + PpsActQpOffsetCb + slice_act_cb_qp_offset + CuQpOffsetCb) \quad (8-289)$$

$$qP_{Cr} = Clip3(-QpBdOffsetC, 57, QpY + PpsActQpOffsetCr + slice_act_cr_qp_offset + CuQpOffsetCr) \quad (8-290)$$

— If ChromaArrayType is equal to 1, the variables qP_{Cb} and qP_{Cr} are set equal to the value of Qp_c as specified in Table 8-10 based on the index qPi equal to qPi_{Cb} and qPi_{Cr} , respectively.

— Otherwise, the variables qP_{Cb} and qP_{Cr} are set equal to $Min(qPi, 51)$, based on the index qPi equal to qPi_{Cb} and qPi_{Cr} , respectively.

— The chroma quantization parameters for the Cb and Cr components, Qp'_{cb} and Qp'_{cr} , are derived as follows:

$$Qp'_{cb} = qP_{Cb} + QpBdOffsetc \quad (8-291)$$

$$Qp'_{cr} = qP_{Cr} + QpBdOffsetc \quad (8-292)$$

Table 8-10 — Specification of Qp_c as a function of qPi for ChromaArrayType equal to 1

qPi	<30	30	31	32	33	34	35	36	37	38	39	40	41	42	43	>43
Qp_c	= qPi	29	30	31	32	33	33	34	34	35	35	36	36	37	37	= $qPi - 6$

8.6.2 Scaling and transformation process

Inputs to this process are

- a luma location ($xTbY, yTbY$) specifying the top-left sample of the current luma transform block relative to the top-left luma sample of the current picture,
- a variable trafoDepth specifying the hierarchy depth of the current block relative to the coding block,
- a variable cIdx specifying the colour component of the current block, and
- a variable nTbS specifying the size of the current transform block.

Output of this process is the $(nTbS) \times (nTbS)$ array of residual samples r with elements $r[x][y]$.

The quantization parameter qP is derived as follows:

— If cIdx is equal to 0, the following applies:

$$qP = Clip3(0, 51 + QpBdOffsetY, Qp'Y + (tu_residual_act_flag[xTbY][yTbY] ? PpsActQpOffsetY + slice_act_y_qp_offset : 0)) \quad (8-293)$$

— Otherwise, if cIdx is equal to 1, the following applies:

$$qP = Qp'_{cb} \quad (8-294)$$

— Otherwise (cIdx is equal to 2), the following applies:

$$qP = Qp'_{cr} \quad (8-295)$$

The variables bitDepth, bdShift and tsShift are derived as follows:

$$\text{bitDepth} = (\text{cIdx} = 0) ? \text{BitDepth}_Y : \text{BitDepth}_C \quad (8-296)$$

$$\text{bdShift} = \text{Max}(20 - \text{bitDepth}, \text{extended_precision_processing_flag} ? 11 : 0) \quad (8-297)$$

$$\text{tsShift} = (\text{extended_precision_processing_flag} ? \text{Min}(5, \text{bdShift} - 2) : 5) + \text{Log2}(\text{nTbS}) \quad (8-298)$$

The variable rotateCoeffs is derived as follows:

— If all of the following conditions are true, rotateCoeffs is set equal to 1:

- transform_skip_rotation_enabled_flag is equal to 1.
- nTbS is equal to 4.
- CuPredMode[xTbY][yTbY] is equal to MODE_INTRA.

— Otherwise, rotateCoeffs is set equal to 0.

The (nTbS)x(nTbS) array of residual samples r is derived as follows:

— If cu_transquant_bypass_flag is equal to 1, the following apply:

- If rotateCoeffs is equal to 1, the residual sample array values r[x][y] with x = 0..nTbS - 1, y = 0..nTbS - 1 are derived as follows:

$$r[x][y] = \text{TransCoeffLevel}[xTbY][yTbY][cIdx][nTbS - x - 1][nTbS - y - 1] \quad (8-299)$$

- Otherwise, the (nTbS)x(nTbS) array r is set equal to the (nTbS)x(nTbS) array of transform coefficients TransCoeffLevel[xTbY][yTbY][cIdx].

— Otherwise, the following ordered steps apply:

1. The scaling process for transform coefficients as specified in 8.6.3 is invoked with the transform block location (xTbY, yTbY), the size of the transform block nTbS, the colour component variable cIdx, and the quantization parameter qp as inputs, and the output is an (nTbS)x(nTbS) array of scaled transform coefficients d.
2. The (nTbS)x(nTbS) array of residual samples r is derived as follows:

- If transform_skip_flag[xTbY][yTbY][cIdx] is equal to 1, the residual sample array values r[x][y] with x = 0..nTbS - 1, y = 0..nTbS - 1 are derived as follows:

$$r[x][y] = (\text{rotateCoeffs} ? d[nTbS - x - 1][nTbS - y - 1] : d[x][y] << \text{tsShift}) \quad (8-300)$$

- Otherwise (transform_skip_flag[xTbY][yTbY][cIdx] is equal to 0), the transformation process for scaled transform coefficients as specified in 8.6.4 is invoked with the transform block location (xTbY, yTbY), the size of the transform block nTbS, the colour component variable cIdx, and the (nTbS)x(nTbS) array of scaled transform coefficients d as inputs, and the output is an (nTbS)x(nTbS) array of residual samples r.

3. The residual sample values r[x][y] with x = 0..nTbS - 1, y = 0..nTbS - 1 are modified as follows:

$$r[x][y] = (r[x][y] + (1 << (\text{bdShift} - 1))) >> \text{bdShift} \quad (8-301)$$

8.6.3 Scaling process for transform coefficients

Inputs to this process are

- a luma location ($xTbY, yTbY$) specifying the top-left sample of the current luma transform block relative to the top-left luma sample of the current picture,
- a variable $nTbS$ specifying the size of the current transform block,
- a variable $cIdx$ specifying the colour component of the current block, and
- a variable qP specifying the quantization parameter.

Output of this process is the $(nTbS) \times (nTbS)$ array d of scaled transform coefficients with elements $d[x][y]$.

The variables $\log_2\text{TransformRange}$, $bdShift$, $coeffMin$ and $coeffMax$ are derived as follows:

- If $cIdx$ is equal to 0, the following apply:

$$\log_2\text{TransformRange} = \text{extended_precision_processing_flag} ? \text{Max}(15, \text{BitDepth}_Y + 6) : 15 \quad (8-302)$$

$$bdShift = \text{BitDepth}_Y + \text{Log}_2(nTbS) + 10 - \log_2\text{TransformRange} \quad (8-303)$$

$$coeffMin = \text{CoeffMin}_Y \quad (8-304)$$

$$coeffMax = \text{CoeffMax}_Y \quad (8-305)$$

- Otherwise, the following apply:

$$\log_2\text{TransformRange} = \text{extended_precision_processing_flag} ? \text{Max}(15, \text{BitDepth}_C + 6) : 15 \quad (8-306)$$

$$bdShift = \text{BitDepth}_C + \text{Log}_2(nTbS) + 10 - \log_2\text{TransformRange} \quad (8-307)$$

$$coeffMin = \text{CoeffMin}_C \quad (8-308)$$

$$coeffMax = \text{CoeffMax}_C \quad (8-309)$$

The list $\text{levelScale}[]$ is specified as $\text{levelScale}[k] = \{ 40, 45, 51, 57, 64, 72 \}$ with $k = 0..5$.

For the derivation of the scaled transform coefficients $d[x][y]$ with $x = 0..nTbS - 1, y = 0..nTbS - 1$, the following applies:

- The scaling factor $m[x][y]$ is derived as follows:

- If one or more of the following conditions are true, $m[x][y]$ is set equal to 16:

- $\text{scaling_list_enabled_flag}$ is equal to 0.

- $\text{transform_skip_flag}[xTbY][yTbY]$ is equal to 1 and $nTbS$ is greater than 4.

- Otherwise, the following applies:

$$m[x][y] = \text{ScalingFactor}[\text{sizeId}][\text{matrixId}][x][y] \quad (8-310)$$

Where sizeId is specified in Table 7-3 for the size of the quantization matrix equal to $(nTbS) \times (nTbS)$ and matrixId is specified in Table 7-4 for sizeId , $\text{CuPredMode}[xTbY][yTbY]$, and $cIdx$, respectively.

- The scaled transform coefficient $d[x][y]$ is derived as follows:

$$d[x][y] = \text{Clip3}(\text{coeffMin}, \text{coeffMax}, ((\text{TransCoeffLevel}[xTbY][yTbY][cIdx][x][y] * m[x][y] * \text{levelScale}[qP \% 6] \ll (qP / 6)) + (1 \ll (bdShift - 1))) \gg bdShift) \quad (8-311)$$

8.6.4 Transformation process for scaled transform coefficients

8.6.4.1 General

Inputs to this process are

- a luma location (xTbY, yTbY) specifying the top-left sample of the current luma transform block relative to the top-left luma sample of the current picture,
- a variable nTbS specifying the size of the current transform block,
- a variable cIdx specifying the colour component of the current block, and
- an (nTbS)x(nTbS) array d of scaled transform coefficients with elements d[x][y].

Output of this process is the (nTbS)x(nTbS) array r of residual samples with elements r[x][y].

The variables coeffMin and coeffMax are derived as follows:

- If cIdx is equal to 0, the following apply:

$$\text{coeffMin} = \text{CoeffMin}_Y \quad (8-312)$$

$$\text{coeffMax} = \text{CoeffMax}_Y \quad (8-313)$$

- Otherwise, the following apply:

$$\text{coeffMin} = \text{CoeffMin}_C \quad (8-314)$$

$$\text{coeffMax} = \text{CoeffMax}_C \quad (8-315)$$

Depending on the values of CuPredMode[xTbY][yTbY], nTbS, and cIdx, the variable trType is derived as follows:

- If CuPredMode[xTbY][yTbY] is equal to MODE_INTRA, nTbS is equal to 4, and cIdx is equal to 0, trType is set equal to 1.
- Otherwise, trType is set equal to 0.

The (nTbS)x(nTbS) array r of residual samples is derived as follows:

1. Each (vertical) column of scaled transform coefficients d[x][y] with $x = 0..nTbS - 1$, $y = 0..nTbS - 1$ is transformed to e[x][y] with $x = 0..nTbS - 1$, $y = 0..nTbS - 1$ by invoking the one-dimensional transformation process as specified in 8.6.4.2 for each column $x = 0..nTbS - 1$ with the size of the transform block nTbS, the list d[x][y] with $y = 0..nTbS - 1$, and the transform type variable trType as inputs, and the output is the list e[x][y] with $y = 0..nTbS - 1$.
2. The intermediate sample values g[x][y] with $x = 0..nTbS - 1$, $y = 0..nTbS - 1$ are derived as follows:

$$g[x][y] = \text{Clip3}(\text{coeffMin}, \text{coeffMax}, (e[x][y] + 64) \gg 7) \quad (8-316)$$

3. Each (horizontal) row of the resulting array g[x][y] with $x = 0..nTbS - 1$, $y = 0..nTbS - 1$ is transformed to r[x][y] with $x = 0..nTbS - 1$, $y = 0..nTbS - 1$ by invoking the one-dimensional transformation process as specified in 8.6.4.2 for each row $y = 0..nTbS - 1$ with the size of the

ISO/IEC 23008-2:2017(E)

transform block $nTbS$, the list $g[x][y]$ with $x = 0..nTbS - 1$, and the transform type variable $trType$ as inputs, and the output is the list $r[x][y]$ with $x = 0..nTbS - 1$.

8.6.4.2 Transformation process

Inputs to this process are

- a variable $nTbS$ specifying the sample size of scaled transform coefficients,
- a list of scaled transform coefficients x with elements $x[j]$, with $j = 0..nTbS - 1$, and
- a transform type variable $trType$

Output of this process is the list of transformed samples y with elements $y[i]$, with $i = 0..nTbS - 1$.

Depending on the value of $trType$, the following apply:

- If $trType$ is equal to 1, the following transform matrix multiplication applies:

$$y[i] = \sum_{j=0}^{nTbS-1} transMatrix[i][j] * x[j] \text{ with } i = 0..nTbS - 1 \quad (8-317)$$

where the transform coefficient array $transMatrix$ is specified as follows:

$$transMatrix = \begin{Bmatrix} \{29 & 55 & 74 & 84\} \\ \{74 & 74 & 0 & -74\} \\ \{84 & -29 & -74 & 55\} \\ \{55 & -84 & 74 & -29\} \end{Bmatrix} \quad (8-318)$$

- Otherwise ($trType$ is equal to 0), the following transform matrix multiplication applies:

$$y[i] = \sum_{j=0}^{nTbS-1} transMatrix[i][j * 2^{5-\text{Log}_2(nTbS)}] * x[j] \text{ with } i = 0..nTbS - 1, \quad (8-319)$$

where the transform coefficient array $transMatrix$ is specified as follows:

$$transMatrix[m][n] = transMatrixCol0to15[m][n] \text{ with } m = 0..15, n = 0..31 \quad (8-320)$$

$$transMatrixCol0to15 = \quad (8-321)$$

```

{
{ 64 64 64 64 64 64 64 64 64 64 64 64 64 64 64 64 }
{ 90 90 88 85 82 78 73 67 61 54 46 38 31 22 13 4 }
{ 90 87 80 70 57 43 25 9 -9 -25 -43 -57 -70 -80 -87 -90 }
{ 90 82 67 46 22 -4 -31 -54 -73 -85 -90 -88 -78 -61 -38 -13 }
{ 89 75 50 18 -18 -50 -75 -89 -89 -75 -50 -18 18 50 75 89 }
{ 88 67 31 -13 -54 -82 -90 -78 -46 -4 38 73 90 85 61 22 }
{ 87 57 9 -43 -80 -90 -70 -25 25 70 90 80 43 -9 -57 -87 }
{ 85 46 -13 -67 -90 -73 -22 38 82 88 54 -4 -61 -90 -78 -31 }
{ 83 36 -36 -83 -83 -36 36 83 83 36 -36 -83 -83 -36 36 83 }
{ 82 22 -54 -90 -61 13 78 85 31 -46 -90 -67 4 73 88 38 }
{ 80 9 -70 -87 -25 57 90 43 -43 -90 -57 25 87 70 -9 -80 }
{ 78 -4 -82 -73 13 85 67 -22 -88 -61 31 90 54 -38 -90 -46 }
{ 75 -18 -89 -50 50 89 18 -75 -75 18 89 50 -50 -89 -18 -75 }
{ 73 -31 -90 -22 78 67 -38 -90 -13 82 61 -46 -88 -4 85 54 }
{ 70 -43 -87 9 90 25 -80 -57 57 80 -25 -90 -9 87 43 -70 }
{ 67 -54 -78 38 85 -22 -90 4 90 13 -88 -31 82 46 -73 -61 }
{ 64 -64 -64 64 64 -64 -64 64 64 -64 -64 64 64 -64 -64 64 }
{ 61 -73 -46 82 31 -88 -13 90 -4 -90 22 85 -38 -78 54 67 }
{ 57 -80 -25 90 -9 -87 43 70 -70 -43 87 9 -90 25 80 -57 }
{ 54 -85 -4 88 -46 -61 82 13 -90 38 67 -78 -22 90 -31 -73 }
{ 50 -89 18 75 -75 -18 89 -50 -50 89 -18 -75 75 18 -89 50 }
{ 46 -90 38 54 -90 31 61 -88 22 67 -85 13 73 -82 4 78 }
{ 43 -90 57 25 -87 70 9 -80 80 -9 -70 87 -25 -57 90 -43 }
{ 38 -88 73 -4 -67 90 -46 -31 85 -78 13 61 -90 54 22 -82 }
{ 36 -83 83 -36 -36 83 -83 36 36 -83 83 -36 -36 83 -83 36 }
{ 31 -78 90 -61 4 54 -88 82 -38 -22 73 -90 67 -13 -46 85 }
{ 25 -70 90 -80 43 9 -57 87 -87 57 -9 -43 80 -90 70 -25 }
{ 22 -61 85 -90 73 -38 -4 46 -78 90 -82 54 -13 -31 67 -88 }
{ 18 -50 75 -89 89 -75 50 -18 -18 50 -75 89 -89 75 -50 18 }
{ 13 -38 61 -78 88 -90 85 -73 54 -31 4 22 -46 67 -82 90 }
{ 9 -25 43 -57 70 -80 87 -90 90 -87 80 -70 57 -43 25 -9 }
{ 4 -13 22 -31 38 -46 54 -61 67 -73 78 -82 85 -88 90 -90 }
},

```

transMatrix[m][n] = transMatrixCol16to31[m - 16][n] with m = 16..31, n = 0..31, (8-322)

transMatrixCol16to31 = (8-323)

```

{
{ 64 64 64 64 64 64 64 64 64 64 64 64 64 64 64 64 }
{ -4 -13 22 -31 -38 -46 -54 -61 -67 -73 -78 -82 -85 -88 -90 -90 }
{ -90 -87 -80 -70 -57 -43 -25 -9 9 25 43 57 70 80 87 90 }
{ 13 38 61 78 88 90 85 73 54 31 4 -22 -46 -67 -82 -90 }
{ 89 75 50 18 -18 -50 -75 -89 -89 -75 -50 -18 18 50 75 89 }
{ 22 -61 -85 -90 -73 -38 4 46 78 90 82 54 13 -31 -67 -88 }
{ -87 -57 -9 43 80 90 70 25 -25 -70 -90 -80 -43 9 57 87 }
{ 31 78 90 61 4 -54 -88 -82 -38 22 73 90 67 13 -46 -85 }
{ 83 36 -36 -83 -83 -36 36 83 83 36 -36 -83 -83 -36 36 83 }
{ -38 -88 -73 -4 67 90 46 -31 -85 -78 -13 61 90 54 -22 -82 }
{ -80 -9 70 87 25 -57 -90 -43 43 90 57 -25 -87 -70 9 80 }
{ 46 90 38 -54 -90 -31 61 88 22 -67 -85 -13 73 82 4 -78 }
{ 75 -18 -89 -50 50 89 18 -75 -75 18 89 50 -50 -89 -18 75 }
{ -54 -85 4 88 46 -61 -82 13 90 38 -67 -78 22 90 31 -73 }
{ -70 43 87 -9 -90 -25 80 57 -57 -80 25 90 9 -87 -43 70 }
{ 61 73 -46 -82 31 88 -13 -90 -4 90 22 -85 -38 78 54 -67 }
{ 64 -64 -64 64 64 -64 -64 64 64 -64 -64 64 64 -64 -64 64 }
{ -67 -54 78 38 -85 -22 90 4 -90 13 88 -31 -82 46 73 -61 }
}

```

```

{-57 80 25 -90 9 87 -43 -70 70 43 -87 -9 90 -25 -80 57}
{ 73 31 -90 22 78 -67 -38 90 -13 -82 61 46 -88 4 85 -54}
{ 50 -89 18 75 -75 -18 89 -50 -50 89 -18 -75 75 18 -89 50}
{-78 -4 82 -73 -13 85 -67 -22 88 -61 -31 90 -54 -38 90 -46}
{-43 90 -57 -25 87 -70 -9 80 -80 9 70 -87 25 57 -90 43}
{ 82 -22 -54 90 -61 -13 78 -85 31 46 -90 67 4 -73 88 -38}
{ 36 -83 83 -36 -36 83 -83 36 36 -83 83 -36 -36 83 -83 36}
{-85 46 13 -67 90 -73 22 38 -82 88 -54 -4 61 -90 78 -31}
{-25 70 -90 80 -43 -9 57 -87 87 -57 9 43 -80 90 -70 25}
{ 88 -67 31 13 -54 82 -90 78 -46 4 38 -73 90 -85 61 -22}
{ 18 -50 75 -89 89 -75 50 -18 -18 50 -75 89 -89 75 -50 18}
{-90 82 -67 46 -22 -4 31 -54 73 -85 90 -88 78 -61 38 -13}
{ -9 25 -43 57 -70 80 -87 90 -90 87 -80 70 -57 43 -25 19}
{ 90 -90 88 -85 82 -78 73 -67 61 -54 46 -38 31 -22 13 -4}
}

```

8.6.5 Residual modification process for blocks using a transform bypass

Inputs to this process are

- a variable *mDir* specifying the residual modification direction,
- a variable *nTbS* specifying the transform block size, and
- an (nTbS)x(nTbS) array of residual samples *r* with elements *r[x][y]*.

Output of this process is the modified (nTbS)x(nTbS) array of residual samples.

Depending upon the value of *mDir*, the (nTbS)x(nTbS) array of samples *r* is modified as follows:

- If *mDir* is equal to 0 (horizontal direction), the array values *r[x][y]* are modified as follows, for *x* proceeding over the values 1..nTbS - 1, and *y* = 0..nTbS - 1:

$$r[x][y] += r[x - 1][y] \tag{8-324}$$

- Otherwise (vertical direction), the array values *r[x][y]* are modified as follows, for *y* proceeding over the values 1..nTbS - 1, and for *x* = 0..nTbS - 1:

$$r[x][y] += r[x][y - 1] \tag{8-325}$$

8.6.6 Residual modification process for transform blocks using cross-component prediction

This process is only invoked when *ChromaArrayType* is equal to 3.

Inputs to this process are

- a luma location (*xTbY*, *yTbY*) specifying the top-left sample of the current luma transform block relative to the top-left luma sample of the current picture,
- a variable *nTbS* specifying the transform block size,
- a variable *cIdx* specifying the colour component of the current block,
- an (nTbS)x(nTbS) array of luma residual samples *r_Y* with elements *r_Y[x][y]*, and
- an (nTbS)x(nTbS) array of residual samples *r* with elements *r[x][y]*.

Output of this process is the modified (nTbS)x(nTbS) array *r* of residual samples.

The (nTbS)x(nTbS) array of residual samples *r* with *x* = 0..nTbS - 1, *y* = 0..nTbS - 1 is modified as follows:

$$r[x][y] += (\text{ResScaleVal}[\text{cIdx}][\text{xTbY}][\text{yTbY}] * (r_y[x][y] \ll \text{BitDepth}_c) \gg \text{BitDepth}_y) \gg 3 \quad (8-326)$$

It is a requirement of bitstream conformance that the luma residual samples $rY[x][y]$ shall be in the range of CoeffMinY to CoeffMaxY , inclusive, and the input residual samples $r[x][y]$ shall be in the range of CoeffMinC to CoeffMaxC , inclusive.

8.6.7 Picture construction process prior to in-loop filter process

Inputs to this process are

- a location $(x_{\text{Curr}}, y_{\text{Curr}})$ specifying the top-left sample of the current block relative to the top-left sample of the current picture component,
- the variables n_{CurrSw} and n_{CurrSh} specifying the width and height, respectively, of the current block,
- a variable cIdx specifying the colour component of the current block,
- an $(n_{\text{CurrSw}}) \times (n_{\text{CurrSh}})$ array predSamples specifying the predicted samples of the current block, and
- an $(n_{\text{CurrSw}}) \times (n_{\text{CurrSh}})$ array resSamples specifying the residual samples of the current block.

Depending on the value of the colour component cIdx , the following assignments are made.

- If cIdx is equal to 0, recSamples corresponds to the reconstructed picture sample array S_L and the function clipCidx1 corresponds to Clip1_Y .
- Otherwise, if cIdx is equal to 1, recSamples corresponds to the reconstructed chroma sample array S_{Cb} and the function clipCidx1 corresponds to Clip1_C .
- Otherwise (cIdx is equal to 2), recSamples corresponds to the reconstructed chroma sample array S_{Cr} and the function clipCidx1 corresponds to Clip1_C .

The $(n_{\text{CurrSw}}) \times (n_{\text{CurrSh}})$ block of the reconstructed sample array recSamples at location $(x_{\text{Curr}}, y_{\text{Curr}})$ is derived as follows:

$$\text{recSamples}[x_{\text{Curr}} + i][y_{\text{Curr}} + j] = \text{clipCidx1}(\text{predSamples}[i][j] + \text{resSamples}[i][j]) \quad (8-327)$$

with $i = 0..n_{\text{CurrSw}} - 1, j = 0..n_{\text{CurrSh}} - 1$

8.6.8 Residual modification process for blocks using adaptive colour transform

This process is only invoked when ChromaArrayType is equal to 3.

8.6.8.1 General

Inputs to this process are

- a sample location $(x_{\text{Tb0}}, y_{\text{Tb0}})$ specifying the top-left sample of the current block relative to the top left sample of the current picture,
- a variable $\log_2\text{TrafoSize}$ specifying the size of the current block,
- a variable trafoDepth specifying the hierarchy depth of the current block relative to the coding unit,
- an array resSampleArrayL specifying the luma residual samples of the current block,
- an array resSampleArrayCb specifying the chroma residual samples of the current block, and

- an array `resSampleArrayCr` specifying the chroma residual samples of the current block.

Outputs of this process are the modified arrays `resSampleY`, `resSampleCb` and `resSampleCr` of residual samples of the current block.

Depending on the value of `split_transform_flag[xTb0][yTb0][trafoDepth]`, the following apply:

- If `split_transform_flag[xTb0][yTb0][trafoDepth]` is equal to 1, the following ordered steps apply:
 1. The variables `xTb1` and `yTb1` are derived as follows:
 - The variable `xTb1` is set equal to $xTb0 + (1 \ll (\log_2TrafoSize - 1))$.
 - The variable `yTb1` is set equal to $yTb0 + (1 \ll (\log_2TrafoSize - 1))$.
 2. The residual modification process for blocks using adaptive colour transform as specified in this subclause is invoked with the location $(xTb0, yTb0)$, the variable `log2TrafoSize` set equal to $\log_2TrafoSize - 1$, the variable `trafoDepth` set equal to `trafoDepth + 1`, the residual sample arrays `resSampleArrayL`, `resSampleArrayCb` and `resSampleArrayCr` as inputs and the output are modified versions of `resSampleArrayL`, `resSampleArrayCb` and `resSampleArrayCr`.
 3. The residual modification process for blocks using adaptive colour transform as specified in this subclause is invoked with the location $(xTb1, yTb0)$, the variable `log2TrafoSize` set equal to $\log_2TrafoSize - 1$, the variable `trafoDepth` set equal to `trafoDepth + 1`, the residual sample arrays `resSampleArrayL`, `resSampleArrayCb` and `resSampleArrayCr` as inputs and the output are modified versions of `resSampleArrayL`, `resSampleArrayCb` and `resSampleArrayCr`.
 4. The residual modification process for blocks using adaptive colour transform as specified in this subclause is invoked with the location $(xTb0, yTb1)$, the variable `log2TrafoSize` set equal to $\log_2TrafoSize - 1$, the variable `trafoDepth` set equal to `trafoDepth + 1`, the residual sample arrays `resSampleArrayL`, `resSampleArrayCb` and `resSampleArrayCr` as inputs and the output are modified versions of `resSampleArrayL`, `resSampleArrayCb` and `resSampleArrayCr`.
 5. The residual modification process for blocks using adaptive colour transform as specified in this subclause is invoked with the location $(xTb1, yTb1)$, the variable `log2TrafoSize` set equal to $\log_2TrafoSize - 1$, the variable `trafoDepth` set equal to `trafoDepth + 1`, the residual sample arrays `resSampleArrayL`, `resSampleArrayCb` and `resSampleArrayCr` as inputs and the output are modified versions of `resSampleArrayL`, `resSampleArrayCb` and `resSampleArrayCr`.
- Otherwise (`split_transform_flag[xTb0][yTb0][trafoDepth]` is equal to 0), the following ordered steps apply:
 1. The variable `nTbS` specifying the current transform block is set equal to $(1 \ll \log_2TrafoSize)$.
 2. The variable `nCbS` specifying the size of the current coding block is derived as $nCbS = 1 \ll (\log_2TrafoSize + trafoDepth)$.
 3. The sample location $(xTbInCb, yTbInCb)$ specifying the top-left sample of the current transform block relative to the top-left sample of the current coding block are derived as $xTbInCb = xTb0 \& (nCbS - 1)$ and $yTbInCb = yTb0 \& (nCbS - 1)$.
 4. When `tu_residual_act_flag[xTb0][yTb0]` is equal to 1, the adaptive colour transformation process as specified in 8.6.8.2 is invoked with the sample location $(xTb0, yTb0)$ set to $(xTbInCb, yTbInCb)$, the variable `blkSize` set equal to `nTbS`, the array `rY` set equal to `resSampleArrayL`, the array `rCb` set equal to `resSampleArrayCb`, and the array `rCr` set equal to `resSampleArrayCr` as inputs, and the outputs are modified versions of the three residual sample arrays.

8.6.8.2 Adaptive colour transformation process

Inputs to this process are

- a sample location ($xTb0$, $yTb0$) specifying the top-left sample of the current transform block relative to the top left sample of the current coding block,
- a variable $blkSize$ specifying the block size of the transform block to be modified,
- an array of luma residual samples rY of the current coding block,
- an array of chroma residual samples rCb of the current coding block, and
- an array of chroma residual samples rCr of the current coding block.

Outputs of this process are

- a modified array rY of luma residual samples,
- a modified array rCb of chroma residual samples, and
- a modified array rCr of chroma residual samples.

The arrays of residual samples rY , rCb and rCr with $x = xTb0..xTb0 + blkSize - 1$, $y = yTb0..yTb0 + blkSize - 1$ are modified as follows:

$$rY[x][y] = \text{Clip3}(\text{CoeffMinY}, \text{CoeffMaxY}, rY[x][y]) \quad (8-328)$$

$$rCb[x][y] = \text{Clip3}(\text{CoeffMinC}, \text{CoeffMaxC}, rCb[x][y]) \quad (8-329)$$

$$rCr[x][y] = \text{Clip3}(\text{CoeffMinC}, \text{CoeffMaxC}, rCr[x][y]) \quad (8-330)$$

- When $cu_transquant_bypass_flag$ is equal to 0, the following ordered steps apply:

1. The variables deltaBDY and deltaBDC are derived as follows:

$$\text{deltaBDY} = \text{Max}(\text{BitDepth}_Y, \text{BitDepth}_C) - \text{BitDepth}_Y \quad (8-331)$$

$$\text{deltaBDC} = \text{Max}(\text{BitDepth}_Y, \text{BitDepth}_C) - \text{BitDepth}_C \quad (8-332)$$

$$\text{offsetBDY} = \text{deltaBDY} ? 1 \ll (\text{deltaBDY} - 1) : 0 \quad (8-333)$$

$$\text{offsetBDC} = \text{deltaBDC} ? 1 \ll (\text{deltaBDC} - 1) : 0 \quad (8-334)$$

2. Residual samples $rY[x][y]$, $rCb[x][y]$ and $rCr[x][y]$ are modified as follows:

$$rY[x][y] = rY[x][y] \ll \text{deltaBDY} \quad (8-335)$$

$$rCb[x][y] = rCb[x][y] \ll (\text{deltaBDC} + 1) \quad (8-336)$$

$$rCr[x][y] = rCr[x][y] \ll (\text{deltaBDC} + 1) \quad (8-337)$$

- Residual samples $rY[x][y]$, $rCb[x][y]$ and $rCr[x][y]$ are modified as follows:

$$\text{tmp} = rY[x][y] - (rCb[x][y] \gg 1) \quad (8-338)$$

$$rY[x][y] = \text{tmp} + rCb[x][y] \quad (8-339)$$

$$rCb[x][y] = \text{tmp} - (rCr[x][y] \gg 1) \quad (8-340)$$

$$rCr[x][y] += rCb[x][y] \quad (8-341)$$

— When `cu_transquant_bypass_flag` is equal to 0, the following apply:

$$rY[x][y] = (rY[x][y] + offsetBDY) \gg \text{deltaBDY} \quad (8-342)$$

$$rCb[x][y] = (rCb[x][y] + offsetBDC) \gg \text{deltaBDC} \quad (8-343)$$

$$rCr[x][y] = (rCr[x][y] + offsetBDC) \gg \text{deltaBDC} \quad (8-344)$$

8.7 In-loop filter process

8.7.1 General

This subclause specifies the application of two in-loop filters. When the in-loop filter process is specified as optional in Annex A, the application of either or both of these filters is optional.

The two in-loop filters, namely deblocking filter and sample adaptive offset filter, are applied as specified by the following ordered steps.

1. For the deblocking filter, the following apply:
 - The deblocking filter process as specified in 8.7.2 is invoked with the reconstructed picture sample array S_L and, when `ChromaArrayType` is not equal to 0, the arrays S_{Cb} and S_{Cr} as inputs, and the modified reconstructed picture sample array S'_L and, when `ChromaArrayType` is not equal to 0, the arrays S'_{Cb} and S'_{Cr} after deblocking as outputs.
 - The array S'_L and, when `ChromaArrayType` is not equal to 0, the arrays S'_{Cb} and S'_{Cr} are assigned to the array S_L and, when `ChromaArrayType` is not equal to 0, the arrays S_{Cb} and S_{Cr} (which represent the decoded picture), respectively.
2. When `sample_adaptive_offset_enabled_flag` is equal to 1, the following apply:
 - The sample adaptive offset process as specified in 8.7.3 is invoked with the reconstructed picture sample array S_L and, when `ChromaArrayType` is not equal to 0, the arrays S_{Cb} and S_{Cr} as inputs, and the modified reconstructed picture sample array S'_L and, when `ChromaArrayType` is not equal to 0, the arrays S'_{Cb} and S'_{Cr} after sample adaptive offset as outputs.
 - The array S'_L and, when `ChromaArrayType` is not equal to 0, the arrays S'_{Cb} and S'_{Cr} are assigned to the array S_L and, when `ChromaArrayType` is not equal to 0, the arrays S_{Cb} and S_{Cr} (which represent the decoded picture), respectively.

8.7.2 Deblocking filter process

8.7.2.1 General

Inputs to this process are the reconstructed picture prior to deblocking, i.e. the array $recPicture_L$ and, when `ChromaArrayType` is not equal to 0, the arrays $recPicture_{Cb}$ and $recPicture_{Cr}$.

Outputs of this process are the modified reconstructed picture after deblocking, i.e. the array $recPicture_L$ and, when `ChromaArrayType` is not equal to 0, the arrays $recPicture_{Cb}$ and $recPicture_{Cr}$.

The vertical edges in a picture are filtered first. Then the horizontal edges in a picture are filtered with samples modified by the vertical edge filtering process as input. The vertical and horizontal edges in the coding tree blocks of each coding tree unit are processed separately on a coding unit basis. The vertical edges of the coding blocks in a coding unit are filtered starting with the edge on the left-hand side of the coding blocks proceeding through the edges towards the right-hand side of the coding blocks in their geometrical order. The horizontal edges of the coding blocks in a coding unit are filtered starting with

the edge on the top of the coding blocks proceeding through the edges towards the bottom of the coding blocks in their geometrical order.

NOTE Although the filtering process is specified on a picture basis in this document, the filtering process can be implemented on a coding unit basis with an equivalent result, provided the decoder properly accounts for the processing dependency order so as to produce the same output values.

The deblocking filter process is applied to all prediction block edges and transform block edges of a picture, except the edges that are at the boundary of the picture, for which the deblocking filter process is disabled by `slice_deblocking_filter_disabled_flag`, that coincide with tile boundaries when `loop_filter_across_tiles_enabled_flag` is equal to 0, or that coincide with upper or left slice boundaries of slices with `slice_loop_filter_across_slices_enabled_flag` equal to 0. For the transform units and prediction units with block edges less than 8 samples in either the vertical or horizontal direction, only the edges lying on the 8x8 sample grid of the considered component are filtered.

The edge type, vertical or horizontal, is represented by the variable `edgeType` as specified in Table 8-11.

Table 8-11 – Name of association to `edgeType`

<code>edgeType</code>	Name of <code>edgeType</code>
0 (vertical edge)	EDGE_VER
1 (horizontal edge)	EDGE_HOR

When `slice_deblocking_filter_disabled_flag` of the current slice is equal to 0, for each coding unit with luma coding block size `log2CbSize` and location of top-left sample of the luma coding block (`xCb, yCb`), the vertical edges are filtered by the following ordered steps:

1. The luma coding block size `nCbS` is set equal to $1 \ll \log_2 \text{CbSize}$.
2. The variable `filterLeftCbEdgeFlag` is derived as follows:
 - If one or more of the following conditions are true, `filterLeftCbEdgeFlag` is set equal to 0:
 - The left boundary of the current luma coding block is the left boundary of the picture.
 - The left boundary of the current luma coding block is the left boundary of the tile and `loop_filter_across_tiles_enabled_flag` is equal to 0.
 - The left boundary of the current luma coding block is the left boundary of the slice and `slice_loop_filter_across_slices_enabled_flag` is equal to 0.
 - Otherwise, `filterLeftCbEdgeFlag` is set equal to 1.
3. All elements of the two-dimensional (`nCbS`)x(`nCbS`) array `verEdgeFlags` are initialized to be equal to zero.
4. The derivation process of transform block boundary specified in 8.7.2.2 is invoked with the luma location (`xCb, yCb`), the luma location (`xB0, yB0`) set equal to (0, 0), the transform block size `log2TrafoSize` set equal to `log2CbSize`, the variable `trafoDepth` set equal to 0, the variable `filterLeftCbEdgeFlag`, the array `verEdgeFlags`, and the variable `edgeType` set equal to EDGE_VER as inputs, and the modified array `verEdgeFlags` as output.
5. The derivation process of prediction block boundary specified in 8.7.2.3 is invoked with the luma coding block size `log2CbSize`, the prediction partition mode `PartMode`, the array `verEdgeFlags`, and the variable `edgeType` set equal to EDGE_VER as inputs, and the modified array `verEdgeFlags` as output.

6. The derivation process of the boundary filtering strength specified in 8.7.2.4 is invoked with the reconstructed luma picture sample array prior to deblocking recPicture_L , the luma location (x_{Cb}, y_{Cb}) , the luma coding block size $\log_2\text{CbSize}$, the variable edgeType set equal to EDGE_VER , and the array verEdgeFlags as inputs, and an $(n_{CbS}) \times (n_{CbS})$ array verBs as output.
7. The vertical edge filtering process for a coding unit as specified in 8.7.2.5.1 is invoked with the reconstructed picture prior to deblocking, i.e. the array recPicture_L and, when ChromaArrayType is not equal to 0, the arrays recPicture_{Cb} and recPicture_{Cr} , the luma location (x_{Cb}, y_{Cb}) , the luma coding block size $\log_2\text{CbSize}$, and the array verBs as inputs, and the modified reconstructed picture, i.e. the array recPicture_L and, when ChromaArrayType is not equal to 0, the arrays recPicture_{Cb} and recPicture_{Cr} , as output.

When $\text{slice_deblocking_filter_disabled_flag}$ of the current slice is equal to 0, for each coding unit with luma coding block size $\log_2\text{CbSize}$ and location of top-left sample of the luma coding block (x_{Cb}, y_{Cb}) , the horizontal edges are filtered by the following ordered steps:

1. The luma coding block size n_{CbS} is set equal to $1 \ll \log_2\text{CbSize}$.
2. The variable $\text{filterTopCbEdgeFlag}$ is derived as follows:
 - If one or more of the following conditions are true, the variable $\text{filterTopCbEdgeFlag}$ is set equal to 0:
 - The top boundary of the current luma coding block is the top boundary of the picture.
 - The top boundary of the current luma coding block is the top boundary of the tile and $\text{loop_filter_across_tiles_enabled_flag}$ is equal to 0.
 - The top boundary of the current luma coding block is the top boundary of the slice and $\text{slice_loop_filter_across_slices_enabled_flag}$ is equal to 0.
 - Otherwise, the variable $\text{filterTopCbEdgeFlag}$ is set equal to 1.
3. All elements of the two-dimensional $(n_{CbS}) \times (n_{CbS})$ array horEdgeFlags are initialized to zero.
4. The derivation process of transform block boundary specified in 8.7.2.2 is invoked with the luma location (x_{Cb}, y_{Cb}) , the luma location (x_{B0}, y_{B0}) set equal to $(0, 0)$, the transform block size $\log_2\text{TrafoSize}$ set equal to $\log_2\text{CbSize}$, the variable trafoDepth set equal to 0, the variable $\text{filterTopCbEdgeFlag}$, the array horEdgeFlags , and the variable edgeType set equal to EDGE_HOR as inputs, and the modified array horEdgeFlags as output.
5. The derivation process of prediction block boundary specified in 8.7.2.3 is invoked with the luma coding block size $\log_2\text{CbSize}$, the prediction partition mode PartMode , the array horEdgeFlags , and the variable edgeType set equal to EDGE_HOR as inputs, and the modified array horEdgeFlags as output.
6. The derivation process of the boundary filtering strength specified in 8.7.2.4 is invoked with the reconstructed luma picture sample array prior to deblocking recPicture_L , the luma location (x_{Cb}, y_{Cb}) , the luma coding block size $\log_2\text{CbSize}$, the variable edgeType set equal to EDGE_HOR , and the array horEdgeFlags as inputs, and an $(n_{CbS}) \times (n_{CbS})$ array horBs as output.
7. The horizontal edge filtering process for a coding unit as specified in 8.7.2.5.2 is invoked with the modified reconstructed picture, i.e. the array recPicture_L and, when ChromaArrayType is not equal to 0, the arrays recPicture_{Cb} and recPicture_{Cr} , the luma location (x_{Cb}, y_{Cb}) , the luma coding block size $\log_2\text{CbSize}$, and the array horBs as inputs, and the modified reconstructed picture, i.e. the

array recPicture_L and, when ChromaArrayType is not equal to 0, the arrays recPicture_{Cb} and recPicture_{Cr} , as output.

8.7.2.2 Derivation process of transform block boundary

Inputs to this process are

- a luma location (x_{Cb}, y_{Cb}) specifying the top-left sample of the current luma coding block relative to the top-left luma sample of the current picture,
- a luma location (x_{B0}, y_{B0}) specifying the top-left sample of the current luma block relative to the top-left sample of the current luma coding block,
- a variable $\log_2\text{TrafoSize}$ specifying the size of the current block,
- a variable trafoDepth ,
- a variable filterEdgeFlag ,
- a two-dimensional $(n_{CbS}) \times (n_{CbS})$ array edgeFlags , and
- a variable edgeType specifying whether a vertical (EDGE_VER) or a horizontal (EDGE_HOR) edge is filtered.

Output of this process is the modified two-dimensional $(n_{CbS}) \times (n_{CbS})$ array edgeFlags .

Depending on the value of $\text{split_transform_flag}[x_{Cb} + x_{B0}][y_{Cb} + y_{B0}][\text{trafoDepth}]$, the following applies.

- If $\text{split_transform_flag}[x_{Cb} + x_{B0}][y_{Cb} + y_{B0}][\text{trafoDepth}]$ is equal to 1, the following ordered steps apply:
 1. The variables x_{B1} and y_{B1} are derived as follows:
 - The variable x_{B1} is set equal to $x_{B0} + (1 \ll (\log_2\text{TrafoSize} - 1))$.
 - The variable y_{B1} is set equal to $y_{B0} + (1 \ll (\log_2\text{TrafoSize} - 1))$.
 2. The derivation process of transform block boundary as specified in this subclause is invoked with the luma location (x_{Cb}, y_{Cb}) , the luma location (x_{B0}, y_{B0}) , the variable $\log_2\text{TrafoSize}$ set equal to $\log_2\text{TrafoSize} - 1$, the variable trafoDepth set equal to $\text{trafoDepth} + 1$, the variable filterEdgeFlag , the array edgeFlags , and the variable edgeType as inputs, and the output is the modified version of array edgeFlags .
 3. The derivation process of transform block boundary as specified in this subclause is invoked with the luma location (x_{Cb}, y_{Cb}) , the luma location (x_{B1}, y_{B0}) , the variable $\log_2\text{TrafoSize}$ set equal to $\log_2\text{TrafoSize} - 1$, the variable trafoDepth set equal to $\text{trafoDepth} + 1$, the variable filterEdgeFlag , the array edgeFlags , and the variable edgeType as inputs, and the output is the modified version of array edgeFlags .
 4. The derivation process of transform block boundary as specified in this subclause is invoked with the luma location (x_{Cb}, y_{Cb}) , the luma location (x_{B0}, y_{B1}) , the variable $\log_2\text{TrafoSize}$ set equal to $\log_2\text{TrafoSize} - 1$, the variable trafoDepth set equal to $\text{trafoDepth} + 1$, the variable filterEdgeFlag , the array edgeFlags , and the variable edgeType as inputs, and the output is the modified version of array edgeFlags .
 5. The derivation process of transform block boundary as specified in this subclause is invoked with the luma location (x_{Cb}, y_{Cb}) , the luma location (x_{B1}, y_{B1}) , the variable $\log_2\text{TrafoSize}$

ISO/IEC 23008-2:2017(E)

set equal to $\log_2\text{TrafoSize} - 1$, the variable trafoDepth set equal to $\text{trafoDepth} + 1$, the variable filterEdgeFlag , the array edgeFlags , and the variable edgeType as inputs, and the output is the modified version of array edgeFlags .

- Otherwise ($\text{split_transform_flag}[\text{xCb} + \text{xB0}][\text{yCb} + \text{yB0}][\text{trafoDepth}]$ is equal to 0), the following apply:
 - If edgeType is equal to EDGE_VER , the value of $\text{edgeFlags}[\text{xB0}][\text{yB0} + k]$ for $k = 0..(1 \ll \log_2\text{TrafoSize}) - 1$ is derived as follows:
 - If xB0 is equal to 0, $\text{edgeFlags}[\text{xB0}][\text{yB0} + k]$ is set equal to filterEdgeFlag .
 - Otherwise, $\text{edgeFlags}[\text{xB0}][\text{yB0} + k]$ is set equal to 1.
 - Otherwise (edgeType is equal to EDGE_HOR), the value of $\text{edgeFlags}[\text{xB0} + k][\text{yB0}]$ for $k = 0..(1 \ll \log_2\text{TrafoSize}) - 1$ is derived as follows:
 - If yB0 is equal to 0, $\text{edgeFlags}[\text{xB0} + k][\text{yB0}]$ is set equal to filterEdgeFlag .
 - Otherwise, $\text{edgeFlags}[\text{xB0} + k][\text{yB0}]$ is set equal to 1.

8.7.2.3 Derivation process of prediction block boundary

Inputs to this process are

- a variable $\log_2\text{CbSize}$ specifying the luma coding block size,
- a prediction partition mode PartMode ,
- a two-dimensional $(\text{nCbS}) \times (\text{nCbS})$ array edgeFlags , and
- a variable edgeType specifying whether a vertical (EDGE_VER) or a horizontal (EDGE_HOR) edge is filtered.

Output of this process is the modified two-dimensional $(\text{nCbS}) \times (\text{nCbS})$ array edgeFlags .

Depending on the values of edgeType and PartMode , the following applies for $k = 0..(1 \ll \log_2\text{CbSize}) - 1$:

- If edgeType is equal to EDGE_VER , the following apply:
 - When PartMode is equal to PART_Nx2N or PART_NxN , $\text{edgeFlags}[1 \ll (\log_2\text{CbSize} - 1)][k]$ is set equal to 1.
 - When PartMode is equal to PART_nLx2N , $\text{edgeFlags}[1 \ll (\log_2\text{CbSize} - 2)][k]$ is set equal to 1.
 - When PartMode is equal to PART_nRx2N , $\text{edgeFlags}[3 * (1 \ll (\log_2\text{CbSize} - 2))][k]$ is set equal to 1.
- Otherwise (edgeType is equal to EDGE_HOR), the following apply:
 - When PartMode is equal to PART_2NxN or PART_NxN , $\text{edgeFlags}[k][1 \ll (\log_2\text{CbSize} - 1)]$ is set equal to 1.
 - When PartMode is equal to PART_2NxN U, $\text{edgeFlags}[k][1 \ll (\log_2\text{CbSize} - 2)]$ is set equal to 1.

- When PartMode is equal to PART_2NxND, edgeFlags[k][3 * (1 << (log2CbSize - 2))] is set equal to 1.

8.7.2.4 Derivation process of boundary filtering strength

Inputs to this process are

- a luma picture sample array recPicture_L,
- a luma location (xCb, yCb) specifying the top-left sample of the current luma coding block relative to the top-left luma sample of the current picture,
- a variable log2CbSize specifying the size of the current luma coding block,
- a variable edgeType specifying whether a vertical (EDGE_VER) or a horizontal (EDGE_HOR) edge is filtered, and
- a two-dimensional (nCbs)x(nCbs) array edgeFlags.

Output of this process is a two-dimensional (nCbs)x(nCbs) array bS specifying the boundary filtering strength.

The variables xD_i, yD_j, xN, and yN are derived as follows:

- If edgeType is equal to EDGE_VER, xD_i is set equal to (i << 3), yD_j is set equal to (j << 2), xN is set equal to (1 << (log2CbSize - 3)) - 1, and yN is set equal to (1 << (log2CbSize - 2)) - 1.
- Otherwise (edgeType is equal to EDGE_HOR), xD_i is set equal to (i << 2), yD_j is set equal to (j << 3), xN is set equal to (1 << (log2CbSize - 2)) - 1, and yN is set equal to (1 << (log2CbSize - 3)) - 1.

For xD_i with i = 0..xN and yD_j with j = 0..yN, the following apply:

- If edgeFlags[xD_i][yD_j] is equal to 0, the variable bS[xD_i][yD_j] is set equal to 0.
- Otherwise (edgeFlags[xD_i][yD_j] is equal to 1), the following apply:
 - The sample values p₀ and q₀ are derived as follows:
 - If edgeType is equal to EDGE_VER, p₀ is set equal to recPicture_L[xCb + xD_i - 1][yCb + yD_j] and q₀ is set equal to recPicture_L[xCb + xD_i][yCb + yD_j].
 - Otherwise (edgeType is equal to EDGE_HOR), p₀ is set equal to recPicture_L[xCb + xD_i][yCb + yD_j - 1] and q₀ is set equal to recPicture_L[xCb + xD_i][yCb + yD_j].
 - The variable bS[xD_i][yD_j] is derived as follows:
 - If the sample p₀ or q₀ is in the luma coding block of a coding unit coded with intra prediction mode, bS[xD_i][yD_j] is set equal to 2.
 - Otherwise, if the block edge is also a transform block edge and the sample p₀ or q₀ is in a luma transform block which contains one or more non-zero transform coefficient levels, bS[xD_i][yD_j] is set equal to 1.
 - Otherwise, if one or more of the following conditions are true, bS[xD_i][yD_j] is set equal to 1:

- For the prediction of the luma prediction block containing the sample p_0 different reference pictures or a different number of motion vectors are used than for the prediction of the luma prediction block containing the sample q_0 .

NOTE 1 The determination of whether the reference pictures used for the two luma prediction blocks are the same or different is based only on which pictures are referenced, without regard to whether a prediction is formed using an index into reference picture list 0 or an index into reference picture list 1, and also without regard to whether the index position within a reference picture list is different.

NOTE 2 The number of motion vectors that are used for the prediction of a luma prediction block with top-left luma sample covering (xPb, yPb) , is equal to $PredFlagL0[xPb][yPb] + PredFlagL1[xPb][yPb]$.

- One motion vector is used to predict the luma prediction block containing the sample p_0 and one motion vector is used to predict the luma prediction block containing the sample q_0 , and the absolute difference between the horizontal or vertical component of the motion vectors used is greater than or equal to 4 in units of quarter luma samples.
- Two motion vectors and two different reference pictures are used to predict the luma prediction block containing the sample p_0 , two motion vectors for the same two reference pictures are used to predict the luma prediction block containing the sample q_0 , and the absolute difference between the horizontal or vertical component of the two motion vectors used in the prediction of the two luma prediction blocks for the same reference picture is greater than or equal to 4 in units of quarter luma samples.
- Two motion vectors for the same reference picture are used to predict the luma prediction block containing the sample p_0 , two motion vectors for the same reference picture are used to predict the luma prediction block containing the sample q_0 , and both of the following conditions are true:
 - The absolute difference between the horizontal or vertical component of list 0 motion vectors used in the prediction of the two luma prediction blocks is greater than or equal to 4 in quarter luma samples, or the absolute difference between the horizontal or vertical component of the list 1 motion vectors used in the prediction of the two luma prediction blocks is greater than or equal to 4 in units of quarter luma samples.
 - The absolute difference between the horizontal or vertical component of list 0 motion vector used in the prediction of the luma prediction block containing the sample p_0 and the list 1 motion vector used in the prediction of the luma prediction block containing the sample q_0 is greater than or equal to 4 in units of quarter luma samples, or the absolute difference between the horizontal or vertical component of the list 1 motion vector used in the prediction of the luma prediction block containing the sample p_0 and list 0 motion vector used in the prediction of the luma prediction block containing the sample q_0 is greater than or equal to 4 in units of quarter luma samples.
- Otherwise, the variable $bS[xD_i][yD_j]$ is set equal to 0.

8.7.2.5 Edge filtering process

8.7.2.5.1 Vertical edge filtering process

Inputs to this process are

- the picture sample array $recPicture_L$ and, when $ChromaArrayType$ is not equal to 0, the arrays $recPicture_{Cb}$ and $recPicture_{Cr}$,

- a luma location (x_{Cb}, y_{Cb}) specifying the top-left sample of the current luma coding block relative to the top-left luma sample of the current picture,
- a variable $\log_2 CbSize$ specifying the size of the current luma coding block, and
- an array bS specifying the boundary filtering strength.

Outputs of this process are the modified picture sample array $recPicture_L$ and, when $ChromaArrayType$ is not equal to 0, the arrays $recPicture_{Cb}$ and $recPicture_{Cr}$.

The filtering process for edges in the luma coding block of the current coding unit consists of the following ordered steps.

1. The variable nD is set equal to $1 \ll (\log_2 CbSize - 3)$.
2. For xD_k equal to $k \ll 3$ with $k = 0..nD - 1$ and yD_m equal to $m \ll 2$ with $m = 0..nD * 2 - 1$, the following applies:
 - When $bS[xD_k][yD_m]$ is greater than 0, the following ordered steps apply:
 - a. The decision process for luma block edges as specified in 8.7.2.5.3 is invoked with the luma picture sample array $recPicture_L$, the location of the luma coding block (x_{Cb}, y_{Cb}), the luma location of the block (xD_k, yD_m), a variable $edgeType$ set equal to $EDGE_VER$, and the boundary filtering strength $bS[xD_k][yD_m]$ as inputs, and the decisions dE , dEp , and dEq , and the variables β and t_c as outputs.
 - b. The filtering process for luma block edges as specified in 8.7.2.5.4 is invoked with the luma picture sample array $recPicture_L$, the location of the luma coding block (x_{Cb}, y_{Cb}), the luma location of the block (xD_k, yD_m), a variable $edgeType$ set equal to $EDGE_VER$, the decisions dE , dEp , and dEq , and the variables β and t_c as inputs, and the modified luma picture sample array $recPicture_L$ as output.

When $ChromaArrayType$ is not equal to 0, the following applies.

The filtering process for edges in the chroma coding blocks of current coding unit consists of the following ordered steps:

1. The variable nD is set equal to $1 \ll (\log_2 CbSize - 3)$.
2. The variable $edgeSpacing$ is set equal to $8 / SubWidthC$.
3. The variable $edgeSections$ is set equal to $nD * (2 / SubHeightC)$.
4. For xD_k equal to $k * edgeSpacing$ with $k = 0..nD - 1$ and yD_m equal to $m \ll 2$ with $m = 0..edgeSections - 1$, the following applies:
 - When $bS[xD_k * SubWidthC][yD_m * SubHeightC]$ is equal to 2 and $((x_{Cb} / SubWidthC + xD_k) \gg 3) \ll 3$ is equal to $x_{Cb} / SubWidthC + xD_k$, the following ordered steps apply:
 - a. The filtering process for chroma block edges as specified in 8.7.2.5.5 is invoked with the chroma picture sample array $recPicture_{Cb}$, the location of the chroma coding block ($x_{Cb} / SubWidthC, y_{Cb} / SubHeightC$), the chroma location of the block (xD_k, yD_m), a variable $edgeType$ set equal to $EDGE_VER$, and a variable $cQpPicOffset$ set equal to $pps_cb_qp_offset$ as inputs, and the modified chroma picture sample array $recPicture_{Cb}$ as output.
 - b. The filtering process for chroma block edges as specified in 8.7.2.5.5 is invoked with the chroma picture sample array $recPicture_{Cr}$, the location of the chroma coding block

(x_{Cb} / SubWidthC, y_{Cb} / SubHeightC), the chroma location of the block (x_{D_k} , y_{D_m}), a variable edgeType set equal to EDGE_VER, and a variable cQpPicOffset set equal to pps_cr_qp_offset as inputs, and the modified chroma picture sample array recPicture_{Cr} as output.

8.7.2.5.2 Horizontal edge filtering process

Inputs to this process are

- the picture sample array recPicture_L and, when ChromaArrayType is not equal to 0, the arrays recPicture_{Cb} and recPicture_{Cr},
- a luma location (x_{Cb} , y_{Cb}) specifying the top-left sample of the current luma coding block relative to the top-left luma sample of the current picture,
- a variable log2CbSize specifying the size of the current luma coding block, and
- an array bS specifying the boundary filtering strength.

Outputs of this process are the modified picture sample array recPicture_L and, when ChromaArrayType is not equal to 0, the arrays recPicture_{Cb} and recPicture_{Cr}.

The filtering process for edges in the luma coding block of the current coding unit consists of the following ordered steps:

1. The variable nD is set equal to $1 \ll (\log_2 \text{CbSize} - 3)$.
2. For y_{D_m} equal to $m \ll 3$ with $m = 0..nD - 1$, and x_{D_k} equal to $k \ll 2$ with $k = 0..nD * 2 - 1$, the following applies:
 - When $bS[x_{D_k}][y_{D_m}]$ is greater than 0, the following ordered steps apply:
 - a. The decision process for luma block edges as specified in 8.7.2.5.3 is invoked with the luma picture sample array recPicture_L, the location of the luma coding block (x_{Cb} , y_{Cb}), the luma location of the block (x_{D_k} , y_{D_m}), a variable edgeType set equal to EDGE_HOR, and the boundary filtering strength $bS[x_{D_k}][y_{D_m}]$ as inputs, and the decisions dE, dEp, and dEq, and the variables β and t_c as outputs.
 - b. The filtering process for luma block edges as specified in 8.7.2.5.4 is invoked with the luma picture sample array recPicture_L, the location of the luma coding block (x_{Cb} , y_{Cb}), the luma location of the block (x_{D_k} , y_{D_m}), a variable edgeType set equal to EDGE_HOR, the decisions dEp, dEp, and dEq, and the variables β and t_c as inputs, and the modified luma picture sample array recPicture_L as output.

When ChromaArrayType is not equal to 0, the following applies.

The filtering process for edges in the chroma coding blocks of current coding unit consists of the following ordered steps:

1. The variable nD is set equal to $1 \ll (\log_2 \text{CbSize} - 3)$.
2. The variable edgeSpacing is set equal to $8 / \text{SubHeightC}$.
3. The variable edgeSections is set equal to $nD * (2 / \text{SubWidthC})$.
4. For y_{D_m} equal to $m * \text{edgeSpacing}$ with $m = 0..nD - 1$ and x_{D_k} equal to $k \ll 2$ with $k = 0..edgeSections - 1$, the following applies:

- When $bS[xD_k * SubWidthC][yD_m * SubHeightC]$ is equal to 2 and $((yCb / SubHeightC + yD_m) \gg 3) \ll 3$ is equal to $yCb / SubHeightC + yD_m$, the following ordered steps apply:
 - a. The filtering process for chroma block edges as specified in 8.7.2.5.5 is invoked with the chroma picture sample array $recPicture_{Cb}$, the location of the chroma coding block $(x_{Cb} / SubWidthC, y_{Cb} / SubHeightC)$, the chroma location of the block (xD_k, yD_m) , a variable $edgeType$ set equal to $EDGE_HOR$, and a variable $cQpPicOffset$ set equal to $pps_cb_qp_offset$ as inputs, and the modified chroma picture sample array $recPicture_{Cb}$ as output.
 - b. The filtering process for chroma block edges as specified in 8.7.2.5.5 is invoked with the chroma picture sample array $recPicture_{Cr}$, the location of the chroma coding block $(x_{Cb} / SubWidthC, y_{Cb} / SubHeightC)$, the chroma location of the block (xD_k, yD_m) , a variable $edgeType$ set equal to $EDGE_HOR$, and a variable $cQpPicOffset$ set equal to $pps_cr_qp_offset$ as inputs, and the modified chroma picture sample array $recPicture_{Cr}$ as output.

8.7.2.5.3 Decision process for luma block edges

Inputs to this process are

- a luma picture sample array $recPicture_L$,
- a luma location (x_{Cb}, y_{Cb}) specifying the top-left sample of the current luma coding block relative to the top-left luma sample of the current picture,
- a luma location (x_{Bl}, y_{Bl}) specifying the top-left sample of the current luma block relative to the top-left sample of the current luma coding block,
- a variable $edgeType$ specifying whether a vertical ($EDGE_VER$) or a horizontal ($EDGE_HOR$) edge is filtered, and
- a variable bS specifying the boundary filtering strength.

Outputs of this process are

- the variables dE , dEp , and dEq containing decisions, and
- the variables β and t_c .

If $edgeType$ is equal to $EDGE_VER$, the sample values $p_{i,k}$ and $q_{i,k}$ with $i = 0..3$ and $k = 0$ and 3 are derived as follows:

$$q_{i,k} = recPicture_L[xCb + xBl + i][yCb + yBl + k] \quad (8-345)$$

$$p_{i,k} = recPicture_L[xCb + xBl - i - 1][yCb + yBl + k] \quad (8-346)$$

Otherwise ($edgeType$ is equal to $EDGE_HOR$), the sample values $p_{i,k}$ and $q_{i,k}$ with $i = 0..3$ and $k = 0$ and 3 are derived as follows:

$$q_{i,k} = recPicture_L[xCb + xBl + k][yCb + yBl + i] \quad (8-347)$$

$$p_{i,k} = recPicture_L[xCb + xBl + k][yCb + yBl - i - 1] \quad (8-348)$$

The variables Qp_Q and Qp_P are set equal to the Qp_Y values of the coding units which include the coding blocks containing the sample $q_{0,0}$ and $p_{0,0}$, respectively.

The variable qP_L is derived as follows:

ISO/IEC 23008-2:2017(E)

$$q_{pL} = ((Q_{pQ} + Q_{pP} + 1) \gg 1) \quad (8-349)$$

The value of the variable β' is determined as specified in Table 8-12 based on the luma quantization parameter Q derived as follows:

$$Q = \text{Clip3}(0, 51, q_{pL} + (\text{slice_beta_offset_div2} \ll 1)) \quad (8-350)$$

where $\text{slice_beta_offset_div2}$ is the value of the syntax element $\text{slice_beta_offset_div2}$ for the slice that contains sample $q_{0,0}$.

The variable β is derived as follows:

$$\beta = \beta' * (1 \ll (\text{BitDepth}_Y - 8)) \quad (8-351)$$

The value of the variable t_c' is determined as specified in Table 8-12 based on the luma quantization parameter Q derived as follows:

$$Q = \text{Clip3}(0, 53, q_{pL} + 2 * (bS - 1) + (\text{slice_tc_offset_div2} \ll 1)) \quad (8-352)$$

where $\text{slice_tc_offset_div2}$ is the value of the syntax element $\text{slice_tc_offset_div2}$ for the slice that contains sample $q_{0,0}$.

The variable t_c is derived as follows:

$$t_c = t_c' * (1 \ll (\text{BitDepth}_Y - 8)) \quad (8-353)$$

Depending on the value of edgeType , the following apply:

— If edgeType is equal to EDGE_VER , the following ordered steps apply:

1. The variables $dpq0$, $dpq3$, dp , dq , and d are derived as follows:

$$dp0 = \text{Abs}(p_{2,0} - 2 * p_{1,0} + p_{0,0}) \quad (8-354)$$

$$dp3 = \text{Abs}(p_{2,3} - 2 * p_{1,3} + p_{0,3}) \quad (8-355)$$

$$dq0 = \text{Abs}(q_{2,0} - 2 * q_{1,0} + q_{0,0}) \quad (8-356)$$

$$dq3 = \text{Abs}(q_{2,3} - 2 * q_{1,3} + q_{0,3}) \quad (8-357)$$

$$dpq0 = dp0 + dq0 \quad (8-358)$$

$$dpq3 = dp3 + dq3 \quad (8-359)$$

$$dp = dp0 + dp3 \quad (8-360)$$

$$dq = dq0 + dq3 \quad (8-361)$$

$$d = dpq0 + dpq3 \quad (8-362)$$

2. The variables dE , dEp , and dEq are set equal to 0.

3. When d is less than β , the following ordered steps apply:

a. The variable dpq is set equal to $2 * dpq0$.

b. For the sample location $(xCb + xBl, yCb + yBl)$, the decision process for a luma sample as specified in 8.7.2.5.6 is invoked with sample values $p_{0,0}$, $p_{3,0}$, $q_{0,0}$, and $q_{3,0}$, the variables dpq , β , and t_c as inputs, and the output is assigned to the decision $dSam0$.

c. The variable dpq is set equal to $2 * dpq3$.

- d. For the sample location ($x_{Cb} + x_{Bl}, y_{Cb} + y_{Bl} + 3$), the decision process for a luma sample as specified in 8.7.2.5.6 is invoked with sample values $p_{0,3}, p_{3,3}, q_{0,3}$, and $q_{3,3}$, the variables dpq, β , and t_c as inputs, and the output is assigned to the decision d_{Sam3} .
- e. The variable dE is set equal to 1.
- f. When d_{Sam0} is equal to 1 and d_{Sam3} is equal to 1, the variable dE is set equal to 2.
- g. When dp is less than $(\beta + (\beta \gg 1)) \gg 3$, the variable dEp is set equal to 1.
- h. When dq is less than $(\beta + (\beta \gg 1)) \gg 3$, the variable dEq is set equal to 1.

— Otherwise (edgeType is equal to EDGE_HOR), the following ordered steps apply:

1. The variables $dpq0, dpq3, dp, dq$, and d are derived as follows:

$$dp0 = \text{Abs}(p_{2,0} - 2 * p_{1,0} + p_{0,0}) \quad (8-363)$$

$$dp3 = \text{Abs}(p_{2,3} - 2 * p_{1,3} + p_{0,3}) \quad (8-364)$$

$$dq0 = \text{Abs}(q_{2,0} - 2 * q_{1,0} + q_{0,0}) \quad (8-365)$$

$$dq3 = \text{Abs}(q_{2,3} - 2 * q_{1,3} + q_{0,3}) \quad (8-366)$$

$$dpq0 = dp0 + dq0 \quad (8-367)$$

$$dpq3 = dp3 + dq3 \quad (8-368)$$

$$dp = dp0 + dp3 \quad (8-369)$$

$$dq = dq0 + dq3 \quad (8-370)$$

$$d = dpq0 + dpq3 \quad (8-371)$$

2. The variables dE, dEp , and dEq are set equal to 0.
3. When d is less than β , the following ordered steps apply:
 - a. The variable dpq is set equal to $2 * dpq0$.
 - b. For the sample location ($x_{Cb} + x_{Bl}, y_{Cb} + y_{Bl}$), the decision process for a luma sample as specified in 8.7.2.5.6 is invoked with sample values $p_{0,0}, p_{3,0}, q_{0,0}$, and $q_{3,0}$, the variables dpq, β , and t_c as inputs, and the output is assigned to the decision d_{Sam0} .
 - c. The variable dpq is set equal to $2 * dpq3$.
 - d. For the sample location ($x_{Cb} + x_{Bl} + 3, y_{Cb} + y_{Bl}$), the decision process for a luma sample as specified in 8.7.2.5.6 is invoked with sample values $p_{0,3}, p_{3,3}, q_{0,3}$, and $q_{3,3}$, the variables dpq, β , and t_c as inputs, and the output is assigned to the decision d_{Sam3} .
 - e. The variable dE is set equal to 1.
 - f. When d_{Sam0} is equal to 1 and d_{Sam3} is equal to 1, the variable dE is set equal to 2.
 - g. When dp is less than $(\beta + (\beta \gg 1)) \gg 3$, the variable dEp is set equal to 1.
 - h. When dq is less than $(\beta + (\beta \gg 1)) \gg 3$, the variable dEq is set equal to 1.

Table 8-12 — Derivation of threshold variables β' and t_c' from input Q

Q	0	1	2	3	4	5	6	7	8	9	10	11	12	13	14	15	16	17	18
β'	0	0	0	0	0	0	0	0	0	0	0	0	0	0	0	0	6	7	8
t_c'	0	0	0	0	0	0	0	0	0	0	0	0	0	0	0	0	0	0	1
Q	19	20	21	22	23	24	25	26	27	28	29	30	31	32	33	34	35	36	37
β'	9	10	11	12	13	14	15	16	17	18	20	22	24	26	28	30	32	34	36
t_c'	1	1	1	1	1	1	1	1	2	2	2	2	3	3	3	3	4	4	4
Q	38	39	40	41	42	43	44	45	46	47	48	49	50	51	52	53			
β'	38	40	42	44	46	48	50	52	54	56	58	60	62	64	-	-			
t_c'	5	5	6	6	7	8	9	10	11	13	14	16	18	20	22	24			

8.7.2.5.4 Filtering process for luma block edges

Inputs to this process are

- a luma picture sample array $recPicture_L$,
- a luma location (xCb, yCb) specifying the top-left sample of the current luma coding block relative to the top-left luma sample of the current picture,
- a luma location (xBl, yBl) specifying the top-left sample of the current luma block relative to the top-left sample of the current luma coding block,
- a variable $edgeType$ specifying whether a vertical (EDGE_VER) or a horizontal (EDGE_HOR) edge is filtered,
- the variables dE, dEp , and dEq containing decisions, and
- the variables β and t_c .

Output of this process is the modified luma picture sample array $recPicture_L$.

Depending on the value of $edgeType$, the following applies.

- If $edgeType$ is equal to EDGE_VER, the following ordered steps apply:

1. The sample values $p_{i,k}$ and $q_{i,k}$ with $i = 0..3$ and $k = 0..3$ are derived as follows:

$$q_{i,k} = recPicture_L[xCb + xBl + i][yCb + yBl + k] \tag{8-372}$$

$$p_{i,k} = recPicture_L[xCb + xBl - i - 1][yCb + yBl + k] \tag{8-373}$$

2. When dE is not equal to 0, for each sample location ($xCb + xBl, yCb + yBl + k$), $k = 0..3$, the following ordered steps apply:
 - a. The filtering process for a luma sample as specified in 8.7.2.5.7 is invoked with the sample values $p_{i,k}, q_{i,k}$ with $i = 0..3$, the locations (xP_i, yP_i) set equal to ($xCb + xBl - i - 1, yCb + yBl + k$) and (xQ_i, yQ_i) set equal to ($xCb + xBl + i, yCb + yBl + k$) with $i = 0..2$, the decision dE , the variables dEp and dEq , and the variable t_c as inputs, and the number of filtered samples nDp and nDq from each side of the block boundary, and the filtered sample values p_i' and q_i' as outputs.

- b. When nDp is greater than 0, the filtered sample values p_i' with $i = 0..nDp - 1$ replace the corresponding samples inside the sample array $recPicture_L$ as follows:

$$recPicture_L[xCb + xBl - i - 1][yCb + yBl + k] = p_i' \quad (8-374)$$

- c. When nDq is greater than 0, the filtered sample values q_j' with $j = 0..nDq - 1$ replace the corresponding samples inside the sample array $recPicture_L$ as follows:

$$recPicture_L[xCb + xBl + j][yCb + yBl + k] = q_j' \quad (8-375)$$

— Otherwise ($edgeType$ is equal to `EDGE_HOR`), the following ordered steps apply:

1. The sample values $p_{i,k}$ and $q_{i,k}$ with $i = 0..3$ and $k = 0..3$ are derived as follows:

$$q_{i,k} = recPicture_L[xCb + xBl + k][yCb + yBl + i] \quad (8-376)$$

$$p_{i,k} = recPicture_L[xCb + xBl + k][yCb + yBl - i - 1] \quad (8-377)$$

2. When dE is not equal to 0, for each sample location $(xCb + xBl + k, yCb + yBl)$, $k = 0..3$, the following ordered steps apply:

- a. The filtering process for a luma sample as specified in 8.7.2.5.7 is invoked with the sample values $p_{i,k}$, $q_{i,k}$ with $i = 0..3$, the locations (xP_i, yP_i) set equal to $(xCb + xBl + k, yCb + yBl - i - 1)$ and (xQ_i, yQ_i) set equal to $(xCb + xBl + k, yCb + yBl + i)$ with $i = 0..2$, the decision dE , the variables dEp and dEq , and the variable t_c as inputs, and the number of filtered samples nDp and nDq from each side of the block boundary and the filtered sample values p_i' and q_j' as outputs.

- b. When nDp is greater than 0, the filtered sample values p_i' with $i = 0..nDp - 1$ replace the corresponding samples inside the sample array $recPicture_L$ as follows:

$$recPicture_L[xCb + xBl + k][yCb + yBl - i - 1] = p_i' \quad (8-378)$$

- c. When nDq is greater than 0, the filtered sample values q_j' with $j = 0..nDq - 1$ replace the corresponding samples inside the sample array $recPicture_L$ as follows:

$$recPicture_L[xCb + xBl + k][yCb + yBl + j] = q_j' \quad (8-379)$$

8.7.2.5.5 Filtering process for chroma block edges

This process is only invoked when $ChromaArrayType$ is not equal to 0.

Inputs to this process are

- a chroma picture sample array s' ,
- a chroma location (xCb, yCb) specifying the top-left sample of the current chroma coding block relative to the top-left chroma sample of the current picture,
- a chroma location (xBl, yBl) specifying the top-left sample of the current chroma block relative to the top-left sample of the current chroma coding block,
- a variable $edgeType$ specifying whether a vertical (`EDGE_VER`) or a horizontal (`EDGE_HOR`) edge is filtered, and
- a variable $cQpPicOffset$ specifying the picture-level chroma quantization parameter offset.

Output of this process is the modified chroma picture sample array s' .

ISO/IEC 23008-2:2017(E)

If edgeType is equal to EDGE_VER, the values p_i and q_i with $i = 0..1$ and $k = 0..3$ are derived as follows:

$$q_{i,k} = s' [xCb + xBl + i] [yCb + yBl + k] \quad (8-380)$$

$$p_{i,k} = s' [xCb + xBl - i - 1] [yCb + yBl + k] \quad (8-381)$$

Otherwise (edgeType is equal to EDGE_HOR), the sample values p_i and q_i with $i = 0..1$ and $k = 0..3$ are derived as follows:

$$q_{i,k} = s' [xCb + xBl + k] [yCb + yBl + i] \quad (8-382)$$

$$p_{i,k} = s' [xCb + xBl + k] [yCb + yBl - i - 1] \quad (8-383)$$

The variables Qp_Q and Qp_P are set equal to the Qp_Y values of the coding units which include the coding blocks containing the sample $q_{0,0}$ and $p_{0,0}$, respectively.

If ChromaArrayType is equal to 1, the variable Qp_C is determined as specified in Table 8-10 based on the index q_{Pi} derived as follows:

$$q_{Pi} = ((Qp_Q + Qp_P + 1) \gg 1) + cQpPicOffset \quad (8-384)$$

Otherwise (ChromaArrayType is greater than 1), the variable Qp_C is set equal to $\text{Min}(q_{Pi}, 51)$.

NOTE The variable $cQpPicOffset$ provides an adjustment for the value of $pps_cb_qp_offset$ or $pps_cr_qp_offset$, according to whether the filtered chroma component is the Cb or Cr component. However, to avoid the need to vary the amount of the adjustment within the picture, the filtering process does not include an adjustment for the value of $slice_cb_qp_offset$ or $slice_cr_qp_offset$, nor (when $chroma_qp_offset_list_enabled_flag$ is equal to 1) for the value of $CuQpOffset_{Cb}$ or $CuQpOffset_{Cr}$.

The value of the variable t_c' is determined as specified in Table 8-12 based on the chroma quantization parameter Q derived as follows:

$$Q = \text{Clip3}(0, 53, Qp_C + 2 + (\text{slice_tc_offset_div2} \ll 1)) \quad (8-385)$$

where $\text{slice_tc_offset_div2}$ is the value of the syntax element $\text{slice_tc_offset_div2}$ for the slice that contains sample $q_{0,0}$.

The variable t_c is derived as follows:

$$t_c = t_c' * (1 \ll (\text{BitDepth}_c - 8)) \quad (8-386)$$

Depending on the value of edgeType, the following apply:

— If edgeType is equal to EDGE_VER, for each sample location $(xCb + xBl, yCb + yBl + k)$, $k = 0..3$, the following ordered steps apply:

1. The filtering process for a chroma sample as specified in 8.7.2.5.8 is invoked with the sample values $p_{i,k}$, $q_{i,k}$, with $i = 0..1$, the locations $(xCb + xBl - 1, yCb + yBl + k)$ and $(xCb + xBl, yCb + yBl + k)$, and the variable t_c as inputs, and the filtered sample values p_0' and q_0' as outputs.
2. The filtered sample values p_0' and q_0' replace the corresponding samples inside the sample array s' as follows:

$$s' [xCb + xBl] [yCb + yBl + k] = q_0' \quad (8-387)$$

$$s' [xCb + xBl - 1] [yCb + yBl + k] = p_0' \quad (8-388)$$

— Otherwise (edgeType is equal to EDGE_HOR), for each sample location $(xCb + xBl + k, yCb + yBl)$, $k = 0..3$, the following ordered steps apply:

1. The filtering process for a chroma sample as specified in 8.7.2.5.8 is invoked with the sample values $p_{i,k}$, $q_{i,k}$, with $i = 0..1$, the locations $(x_{Cb} + x_{Bl} + k, y_{Cb} + y_{Bl} - 1)$ and $(x_{Cb} + x_{Bl} + k, y_{Cb} + y_{Bl})$, and the variable t_c as inputs, and the filtered sample values p_0' and q_0' as outputs.
2. The filtered sample values p_0' and q_0' replace the corresponding samples inside the sample array s' as follows:

$$s'[x_{Cb} + x_{Bl} + k][y_{Cb} + y_{Bl}] = q_0' \quad (8-389)$$

$$s'[x_{Cb} + x_{Bl} + k][y_{Cb} + y_{Bl} - 1] = p_0' \quad (8-390)$$

8.7.2.5.6 Decision process for a luma sample

Inputs to this process are

- the sample values p_0, p_3, q_0 , and q_3 , and
- the variables dpq, β , and t_c .

Output of this process is the variable $dSam$ containing a decision.

The variable $dSam$ is specified as follows:

- If dpq is less than $(\beta \gg 2)$, $Abs(p_3 - p_0) + Abs(q_0 - q_3)$ is less than $(\beta \gg 3)$, and $Abs(p_0 - q_0)$ is less than $(5 * t_c + 1) \gg 1$, $dSam$ is set equal to 1.
- Otherwise, $dSam$ is set equal to 0.

8.7.2.5.7 Filtering process for a luma sample

Inputs to this process are

- the luma sample values p_i and q_i with $i = 0..3$,
- the luma locations of p_i and q_i , (x_{P_i}, y_{P_i}) and (x_{Q_i}, y_{Q_i}) with $i = 0..2$,
- a variable dE ,
- the variables dEp and dEq containing decisions to filter samples p_1 and q_1 , respectively, and
- a variable t_c .

Outputs of this process are

- the number of filtered samples nDp and nDq , and
- the filtered sample values p_i' and q_j' with $i = 0..nDp - 1, j = 0..nDq - 1$.

Depending on the value of dE , the following apply:

- If the variable dE is equal to 2, nDp and nDq are both set equal to 3, and the following strong filtering apply:

$$p_0' = \text{Clip3}(p_0 - 2 * t_c, p_0 + 2 * t_c, (p_2 + 2 * p_1 + 2 * p_0 + 2 * q_0 + q_1 + 4) \gg 3) \quad (8-391)$$

$$p_1' = \text{Clip3}(p_1 - 2 * t_c, p_1 + 2 * t_c, (p_2 + p_1 + p_0 + q_0 + 2) \gg 2) \quad (8-392)$$

$$p_2' = \text{Clip3}(p_2 - 2 * t_c, p_2 + 2 * t_c, (2 * p_3 + 3 * p_2 + p_1 + p_0 + q_0 + 4) \gg 3) \quad (8-393)$$

ISO/IEC 23008-2:2017(E)

$$q_0' = \text{Clip3}(q_0 - 2 * t_c, q_0 + 2 * t_c, (p_1 + 2 * p_0 + 2 * q_0 + 2 * q_1 + q_2 + 4) \gg 3) \quad (8-394)$$

$$q_1' = \text{Clip3}(q_1 - 2 * t_c, q_1 + 2 * t_c, (p_0 + q_0 + q_1 + q_2 + 2) \gg 2) \quad (8-395)$$

$$q_2' = \text{Clip3}(q_2 - 2 * t_c, q_2 + 2 * t_c, (p_0 + q_0 + q_1 + 3 * q_2 + 2 * q_3 + 4) \gg 3) \quad (8-396)$$

— Otherwise, nDp and nDq are set both equal to 0, and the following weak filtering apply:

— The following applies:

$$\Delta = (9 * (q_0 - p_0) - 3 * (q_1 - p_1) + 8) \gg 4 \quad (8-397)$$

— When Abs(Δ) is less than $t_c * 10$, the following ordered steps apply:

1. The filtered sample values p_0' and q_0' are specified as follows:

$$\Delta = \text{Clip3}(-t_c, t_c, \Delta) \quad (8-398)$$

$$p_0' = \text{Clip1}_Y(p_0 + \Delta) \quad (8-399)$$

$$q_0' = \text{Clip1}_Y(q_0 - \Delta) \quad (8-400)$$

2. When dEp is equal to 1, the filtered sample value p_1' is specified as follows:

$$\Delta p = \text{Clip3}(-(t_c \gg 1), t_c \gg 1, (((p_2 + p_0 + 1) \gg 1) - p_1 + \Delta) \gg 1) \quad (8-401)$$

$$p_1' = \text{Clip1}_Y(p_1 + \Delta p) \quad (8-402)$$

3. When dEq is equal to 1, the filtered sample value q_1' is specified as follows:

$$\Delta q = \text{Clip3}(-(t_c \gg 1), t_c \gg 1, ((q_2 + q_0 + 1) \gg 1) - q_1 - \Delta) \gg 1) \quad (8-403)$$

$$q_1' = \text{Clip1}_Y(q_1 + \Delta q) \quad (8-404)$$

4. nDp is set equal to dEp + 1 and nDq is set equal to dEq + 1.

When nDp is greater than 0 and one or more of the following conditions are true, nDp is set equal to 0:

- pcm_loop_filter_disabled_flag is equal to 1 and pcm_flag[xP₀][yP₀] is equal to 1.
- cu_transquant_bypass_flag of the coding unit that includes the coding block containing the sample p₀ is equal to 1.
- palette_mode_flag of the coding unit that includes the coding block containing the sample p₀ is equal to 1.

When nDq is greater than 0 and one or more of the following conditions are true, nDq is set equal to 0:

- pcm_loop_filter_disabled_flag is equal to 1 and pcm_flag[xQ₀][yQ₀] is equal to 1.
- cu_transquant_bypass_flag of the coding unit that includes the coding block containing the sample q₀ is equal to 1.
- palette_mode_flag of the coding unit that includes the coding block containing the sample q₀ is equal to 1.

8.7.2.5.8 Filtering process for a chroma sample

This process is only invoked when ChromaArrayType is not equal to 0.

Inputs to this process are

- the chroma sample values p_i and q_i with $i = 0..1$,
- the chroma locations of p_0 and q_0 , (xP_0, yP_0) and (xQ_0, yQ_0) , and
- a variable t_c .

Outputs of this process are the filtered sample values p_0' and q_0' .

The filtered sample values p_0' and q_0' are derived as follows:

$$\Delta = \text{Clip3}(-t_c, t_c, (((q_0 - p_0) \ll 2) + p_1 - q_1 + 4) \gg 3)) \quad (8-405)$$

$$p_0' = \text{Clip1}_c(p_0 + \Delta) \quad (8-406)$$

$$q_0' = \text{Clip1}_c(q_0 - \Delta) \quad (8-407)$$

When one or more of the following conditions are true, the filtered sample value p_0' is substituted by the corresponding input sample value p_0 :

- `pcm_loop_filter_disabled_flag` is equal to 1 and `pcm_flag[xP0 * SubWidthC][yP0 * SubHeightC]` is equal to 1.
- `cu_transquant_bypass_flag` of the coding unit that includes the coding block containing the sample p_0 is equal to 1.
- `palette_mode_flag` of the coding unit that includes the coding block containing the sample p_0 is equal to 1.

When one or more of the following conditions are true, the filtered sample value q_0' is substituted by the corresponding input sample value q_0 :

- `pcm_loop_filter_disabled_flag` is equal to 1 and `pcm_flag[xQ0 * SubWidthC][yQ0 * SubHeightC]` is equal to 1.
- `cu_transquant_bypass_flag` of the coding unit that includes the coding block containing the sample q_0 is equal to 1.
- `palette_mode_flag` of the coding unit that includes the coding block containing the sample q_0 is equal to 1.

8.7.3 Sample adaptive offset process

8.7.3.1 General

Inputs to this process are the reconstructed picture sample array prior to sample adaptive offset `recPictureL` and, when ChromaArrayType is not equal to 0, the arrays `recPictureCb` and `recPictureCr`.

Outputs of this process are the modified reconstructed picture sample array after sample adaptive offset `saoPictureL` and, when ChromaArrayType is not equal to 0, the arrays `saoPictureCb` and `saoPictureCr`.

This process is performed on a coding tree block basis after the completion of the deblocking filter process for the decoded picture.

ISO/IEC 23008-2:2017(E)

The sample values in the modified reconstructed picture sample array saoPicture_L and, when ChromaArrayType is not equal to 0, the arrays saoPicture_{Cb} and saoPicture_{Cr} are initially set equal to the sample values in the reconstructed picture sample array recPicture_L and, when ChromaArrayType is not equal to 0, the arrays recPicture_{Cb} and recPicture_{Cr} , respectively.

For every coding tree unit with coding tree block location (rx, ry) , where $rx = 0..PicWidthInCtbsY - 1$ and $ry = 0..PicHeightInCtbsY - 1$, the following apply:

- When $\text{slice_sao_luma_flag}$ of the current slice is equal to 1, the coding tree block modification process as specified in 8.7.3.2 is invoked with recPicture set equal to recPicture_L , cldx set equal to 0, (rx, ry) , and both nCtbSw and nCtbSh set equal to CtbSizeY as inputs, and the modified luma picture sample array saoPicture_L as output.
- When ChromaArrayType is not equal to 0 and $\text{slice_sao_chroma_flag}$ of the current slice is equal to 1, the coding tree block modification process as specified in 8.7.3.2 is invoked with recPicture set equal to recPicture_{Cb} , cldx set equal to 1, (rx, ry) , nCtbSw set equal to $(1 \ll \text{CtbLog2SizeY}) / \text{SubWidthC}$, and nCtbSh set equal to $(1 \ll \text{CtbLog2SizeY}) / \text{SubHeightC}$ as inputs, and the modified chroma picture sample array saoPicture_{Cb} as output.
- When ChromaArrayType is not equal to 0 and $\text{slice_sao_chroma_flag}$ of the current slice is equal to 1, the coding tree block modification process as specified in 8.7.3.2 is invoked with recPicture set equal to recPicture_{Cr} , cldx set equal to 2, (rx, ry) , nCtbSw set equal to $(1 \ll \text{CtbLog2SizeY}) / \text{SubWidthC}$, and nCtbSh set equal to $(1 \ll \text{CtbLog2SizeY}) / \text{SubHeightC}$ as inputs, and the modified chroma picture sample array saoPicture_{Cr} as output.

8.7.3.2 Coding tree block modification process

Inputs to this process are

- the picture sample array recPicture for the colour component cldx ,
- a variable cldx specifying the colour component index,
- a pair of variables (rx, ry) specifying the coding tree block location, and
- the coding tree block width nCtbSw and height nCtbSh .

Output of this process is a modified picture sample array saoPicture for the colour component cldx .

The variable bitDepth is derived as follows:

- If cldx is equal to 0, bitDepth is set equal to BitDepth_Y .
- Otherwise, bitDepth is set equal to BitDepth_C .

The location $(x\text{Ctb}, y\text{Ctb})$, specifying the top-left sample of the current coding tree block for the colour component cldx relative to the top-left sample of the current picture component cldx , is derived as follows:

$$(x\text{Ctb}, y\text{Ctb}) = (rx * \text{nCtbSw}, ry * \text{nCtbSh}) \quad (8-408)$$

The sample locations inside the current coding tree block are derived as follows:

$$(xS_i, yS_j) = (x\text{Ctb} + i, y\text{Ctb} + j) \quad (8-409)$$

$$(xY_i, yY_j) = (\text{cldx} = 0) ? (xS_i, yS_j) : (xS_i * \text{SubWidthC}, yS_j * \text{SubHeightC}) \quad (8-410)$$

For all sample locations (xS_i, yS_j) and (xY_i, yY_j) with $i = 0..n\text{CtbSw} - 1$ and $j = 0..n\text{CtbSh} - 1$, depending on the values of $\text{pcm_loop_filter_disabled_flag}$, $\text{pcm_flag}[xY_i][yY_j]$, and $\text{cu_transquant_bypass_flag}$ of the coding unit which includes the coding block covering $\text{recPicture}[xS_i][yS_j]$, the following apply:

— If one or more of the following conditions are true, $\text{saoPicture}[xS_i][yS_j]$ is not modified:

- $\text{pcm_loop_filter_disabled_flag}$ and $\text{pcm_flag}[xY_i][yY_j]$ are both equal to 1.
- $\text{cu_transquant_bypass_flag}$ is equal to 1.
- $\text{SaoTypeIdx}[cIdx][rx][ry]$ is equal to 0.

— Otherwise, if $\text{SaoTypeIdx}[cIdx][rx][ry]$ is equal to 2, the following ordered steps apply:

1. The values of $\text{hPos}[k]$ and $\text{vPos}[k]$ for $k=0..1$ are specified in Table 8-13 based on $\text{SaoEoClass}[cIdx][rx][ry]$.
2. The variable edgeIdx is derived as follows:

— The modified sample locations (xS_{ik}', yS_{jk}') and (xY_{ik}', yY_{jk}') are derived as follows:

$$(xS_{ik}', yS_{jk}') = (xS_i + \text{hPos}[k], yS_j + \text{vPos}[k]) \quad (8-411)$$

$$(xY_{ik}', yY_{jk}') = (cIdx == 0) ? (xS_{ik}', yS_{jk}') : (xS_{ik}' * \text{SubWidthC}, yS_{jk}' * \text{SubHeightC}) \quad (8-412)$$

— If one or more of the following conditions for all sample locations (xS_{ik}', yS_{jk}') and (xY_{ik}', yY_{jk}') with $k=0..1$ are true, edgeIdx is set equal to 0:

- The sample at location (xS_{ik}', yS_{jk}') is outside the picture boundaries.
- The sample at location (xS_{ik}', yS_{jk}') belongs to a different slice and one of the following two conditions is true:
 - $\text{MinTbAddrZs}[xY_{ik}' \gg \text{MinTbLog2SizeY}][yY_{jk}' \gg \text{MinTbLog2SizeY}]$ is less than $\text{MinTbAddrZs}[xY_i \gg \text{MinTbLog2SizeY}][yY_j \gg \text{MinTbLog2SizeY}]$ and $\text{slice_loop_filter_across_slices_enabled_flag}$ in the slice which the sample $\text{recPicture}[xS_i][yS_j]$ belongs to is equal to 0.
 - $\text{MinTbAddrZs}[xY_i \gg \text{MinTbLog2SizeY}][yY_j \gg \text{MinTbLog2SizeY}]$ is less than $\text{MinTbAddrZs}[xY_{ik}' \gg \text{MinTbLog2SizeY}][yY_{jk}' \gg \text{MinTbLog2SizeY}]$ and $\text{slice_loop_filter_across_slices_enabled_flag}$ in the slice which the sample $\text{recPicture}[xS_{ik}'][yS_{jk}']$ belongs to is equal to 0.
- $\text{loop_filter_across_tiles_enabled_flag}$ is equal to 0 and the sample at location (xS_{ik}', yS_{jk}') belongs to a different tile.
- Otherwise, edgeIdx is derived as follows:

— The following applies:

$$\begin{aligned} \text{edgeIdx} = & \\ & 2 + \text{Sign}(\text{recPicture}[xS_i][yS_j] - \text{recPicture}[xS_i + \text{hPos}[0]][yS_j + \text{vPos}[0]]) + \\ & \text{Sign}(\text{recPicture}[xS_i][yS_j] - \text{recPicture}[xS_i + \text{hPos}[1]][yS_j + \text{vPos}[1]]) \end{aligned} \quad (8-413)$$

— When edgeIdx is equal to 0, 1, or 2, edgeIdx is modified as follows:

$$\text{edgeIdx} = (\text{edgeIdx} == 2) ? 0 : (\text{edgeIdx} + 1) \quad (8-414)$$

3. The modified picture sample array $\text{saoPicture}[xS_i][yS_j]$ is derived as follows:

$$\text{saoPicture}[xS_i][yS_j] = \text{Clip3}(0, (1 \ll \text{bitDepth}) - 1, \text{recPicture}[xS_i][yS_j] + \text{SaoOffsetVal}[\text{cIdx}][\text{rx}][\text{ry}][\text{edgeIdx}]) \quad (8-415)$$

— Otherwise ($\text{SaoTypeIdx}[\text{cIdx}][\text{rx}][\text{ry}]$ is equal to 1), the following ordered steps apply:

1. The variable bandShift is set equal to $\text{bitDepth} - 5$.
2. The variable saoLeftClass is set equal to $\text{sao_band_position}[\text{cIdx}][\text{rx}][\text{ry}]$.
3. The list bandTable is defined with 32 elements and all elements are initially set equal to 0. Then, four of its elements (indicating the starting position of bands for explicit offsets) are modified as follows:

$$\text{for}(k = 0; k < 4; k++) \quad \text{bandTable}[(k + \text{saoLeftClass}) \& 31] = k + 1 \quad (8-416)$$

4. The variable bandIdx is set equal to $\text{bandTable}[\text{recPicture}[xS_i][yS_j] \gg \text{bandShift}]$.
5. The modified picture sample array $\text{saoPicture}[xS_i][yS_j]$ is derived as follows:

$$\text{saoPicture}[xS_i][yS_j] = \text{Clip3}(0, (1 \ll \text{bitDepth}) - 1, \text{recPicture}[xS_i][yS_j] + \text{SaoOffsetVal}[\text{cIdx}][\text{rx}][\text{ry}][\text{bandIdx}]) \quad (8-417)$$

Table 8-13 — Specification of hPos and vPos according to the sample adaptive offset class

$\text{SaoEoClass}[\text{cIdx}][\text{rx}][\text{ry}]$	0	1	2	3
$\text{hPos}[0]$	-1	0	-1	1
$\text{hPos}[1]$	1	0	1	-1
$\text{vPos}[0]$	0	-1	-1	-1
$\text{vPos}[1]$	0	1	1	1

9 Parsing process

9.1 General

Inputs to this process are bits from the RBSP.

Outputs of this process are syntax element values.

This process is invoked when the descriptor of a syntax element in the syntax tables is equal to $\text{ue}(v)$, $\text{se}(v)$ (see 9.2), or $\text{ae}(v)$ (see 9.3).

9.2 Parsing process for 0-th order Exp-Golomb codes

9.2.1 General

This process is invoked when the descriptor of a syntax element in the syntax tables is equal to $\text{ue}(v)$ or $\text{se}(v)$.

Inputs to this process are bits from the RBSP.

Outputs of this process are syntax element values.

Syntax elements coded as $\text{ue}(v)$ or $\text{se}(v)$ are Exp-Golomb-coded. The parsing process for these syntax elements begins with reading the bits starting at the current location in the bitstream up to and including the first non-zero bit, and counting the number of leading bits that are equal to 0. This process is specified as follows:

```

leadingZeroBits = -1
for( b = 0; !b; leadingZeroBits++ )
    b = read_bits( 1 )

```

(9-1)

The variable codeNum is then assigned as follows:

$$\text{codeNum} = 2^{\text{leadingZeroBits}} - 1 + \text{read_bits}(\text{leadingZeroBits})$$

(9-2)

where the value returned from read_bits(leadingZeroBits) is interpreted as a binary representation of an unsigned integer with most significant bit written first.

Table 9-1 illustrates the structure of the Exp-Golomb code by separating the bit string into “prefix” and “suffix” bits. The “prefix” bits are those bits that are parsed as specified above for the computation of leadingZeroBits, and are shown as either 0 or 1 in the bit string column of Table 9-1. The “suffix” bits are those bits that are parsed in the computation of codeNum and are shown as x_i in Table 9-1, with i in the range of 0 to leadingZeroBits – 1, inclusive. Each x_i is equal to either 0 or 1.

Table 9-1 — Bit strings with “prefix” and “suffix” bits and assignment to codeNum ranges (informative)

Bit string form	Range of codeNum
1	0
0 1 x_0	1..2
0 0 1 $x_1 x_0$	3..6
0 0 0 1 $x_2 x_1 x_0$	7..14
0 0 0 0 1 $x_3 x_2 x_1 x_0$	15..30
0 0 0 0 0 1 $x_4 x_3 x_2 x_1 x_0$	31..62
...	...

Table 9-2 illustrates explicitly the assignment of bit strings to codeNum values.

Table 9-2 — Exp-Golomb bit strings and codeNum in explicit form and used as ue(v) (informative)

Bit string	codeNum
1	0
0 1 0	1
0 1 1	2
0 0 1 0 0	3
0 0 1 0 1	4
0 0 1 1 0	5
0 0 1 1 1	6
0 0 0 1 0 0 0	7
0 0 0 1 0 0 1	8
0 0 0 1 0 1 0	9
...	...

Depending on the descriptor, the value of a syntax element is derived as follows:

- If the syntax element is coded as ue(v), the value of the syntax element is equal to codeNum.
- Otherwise (the syntax element is coded as se(v)), the value of the syntax element is derived by invoking the mapping process for signed Exp-Golomb codes as specified in 9.2.2 with codeNum as input.

9.2.2 Mapping process for signed Exp-Golomb codes

Input to this process is codeNum as specified in 9.2.

Output of this process is a value of a syntax element coded as se(v).

The syntax element is assigned to the codeNum by ordering the syntax element by its absolute value in increasing order and representing the positive value for a given absolute value with the lower codeNum. Table 9-3 provides the assignment rule.

Table 9-3 — Assignment of syntax element to codeNum for signed Exp-Golomb coded syntax elements se(v)

codeNum	syntax element value
0	0
1	1
2	-1
3	2
4	-2
5	3
6	-3
k	$(-1)^{k+1} \text{Ceil}(k \div 2)$

9.3 CABAC parsing process for slice segment data

9.3.1 General

This process is invoked when parsing syntax elements with descriptor ae(v) in 7.3.8.1 through 7.3.8.12. Inputs to this process are a request for a value of a syntax element and values of prior parsed syntax elements.

Output of this process is the value of the syntax element.

The initialization process as specified in 9.3.2 is invoked when starting the parsing of one or more of the following:

1. the slice segment data syntax specified in 7.3.8.1;
2. the coding tree unit syntax specified in 7.3.8.2 and the coding tree unit is the first coding tree unit in a tile;
3. the coding tree unit syntax specified in 7.3.8.2, entropy_coding_sync_enabled_flag is equal to 1, and the associated luma coding tree block is the first luma coding tree block in a coding tree unit row of a tile.

The parsing of syntax elements proceeds as follows.

When cabac_bypass_alignment_enabled_flag is equal to 1, the request for a value of a syntax element is for either the syntax elements coeff_abs_level_remaining[] or coeff_sign_flag[], and escapeDataPresent is equal to 1, the alignment process prior to aligned bypass decoding as specified in 9.3.4.3.6 is invoked.

For each requested value of a syntax element, a binarization is derived as specified in 9.3.3.

The binarization for the syntax element and the sequence of parsed bins determines the decoding process flow as described in 9.3.4.

In case the request for a value of a syntax element is processed for the syntax element `pcm_flag` and the decoded value of `pcm_flag` is equal to 1, the decoding engine is initialized after the decoding of any `pcm_alignment_zero_bit` and all `pcm_sample_luma` and `pcm_sample_chroma` data as specified in 9.3.2.6.

The storage process for context variables is applied as follows:

- When ending the parsing of the coding tree unit syntax in 7.3.8.2, `entropy_coding_sync_enabled_flag` is equal to 1 and either `CtbAddrInRs % PicWidthInCtbsY` is equal to 1 or both `CtbAddrInRs` is greater than 1 and `TileId[CtbAddrInTs]` is not equal to `TileId[CtbAddrRsToTs[CtbAddrInRs - 2]]`, the storage process for context variables, Rice parameter initialization states, and palette predictor variables as specified in 9.3.2.3 is invoked with `TableStateIdxWpp`, `TableMpsValWpp`, `TableStatCoeffWpp` when `persistent_rice_adaptation_enabled_flag` is equal to 1, and `PredictorPaletteSizeWpp` and `PredictorPaletteEntriesWpp` when `palette_mode_enabled_flag` is equal to 1 as outputs.
- When ending the parsing of the general slice segment data syntax in 7.3.8.1, `dependent_slice_segments_enabled_flag` is equal to 1 and `end_of_slice_segment_flag` is equal to 1, the storage process for context variables, Rice parameter initialization states, and palette predictor variables as specified in 9.3.2.4 is invoked with `TableStateIdxDs`, `TableMpsValDs`, `TableStatCoeffDs` when `persistent_rice_adaptation_enabled_flag` is equal to 1, and `PredictorPaletteSizeDs` and `PredictorPaletteEntriesDs` when `palette_mode_enabled_flag` is equal to 1 as outputs.

The whole CABAC parsing process for a syntax element `synEl` is illustrated in Figure 9-1.

STANDARDSISO.COM : Click to view the full PDF of ISO/IEC 23008-2:2017

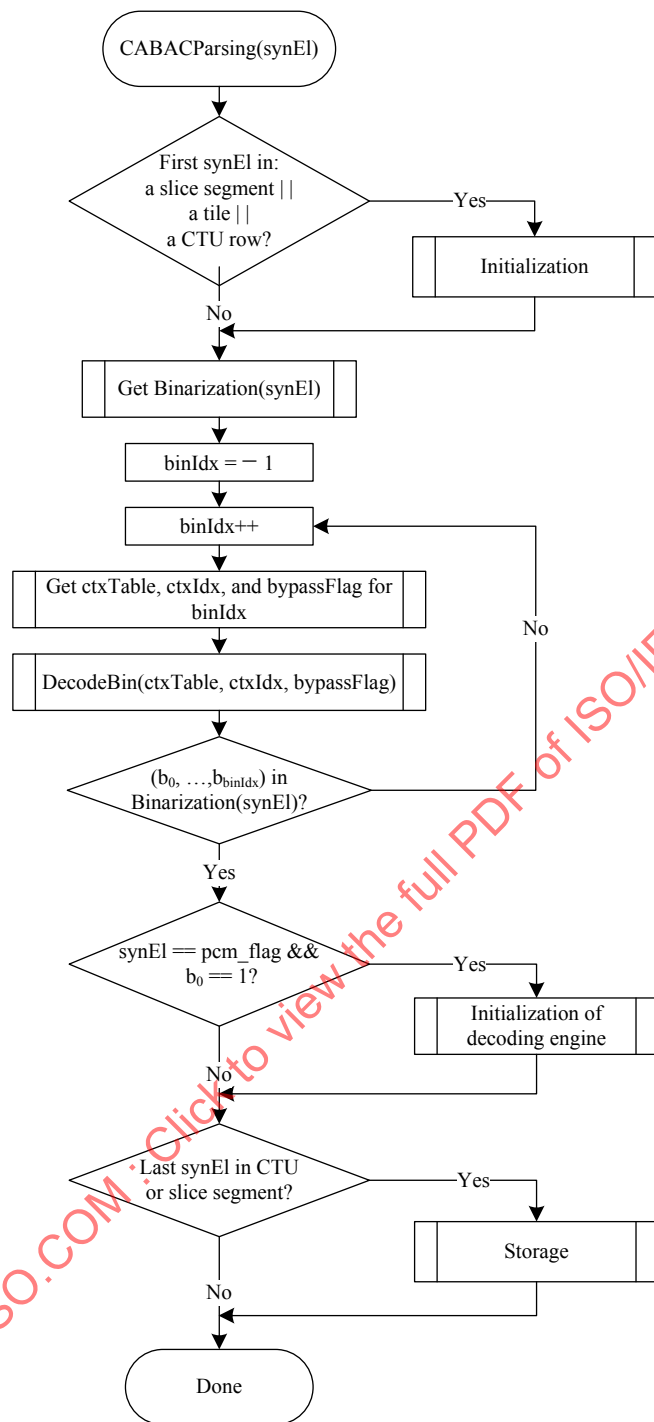

Figure 9-1 — CABAC parsing process for a syntax element synEl (informative)

9.3.2 Initialization process

9.3.2.1 General

Outputs of this process are initialized CABAC internal variables, the initialized Rice parameter initialization states StatCoeff, and the initialized palette predictor variables.

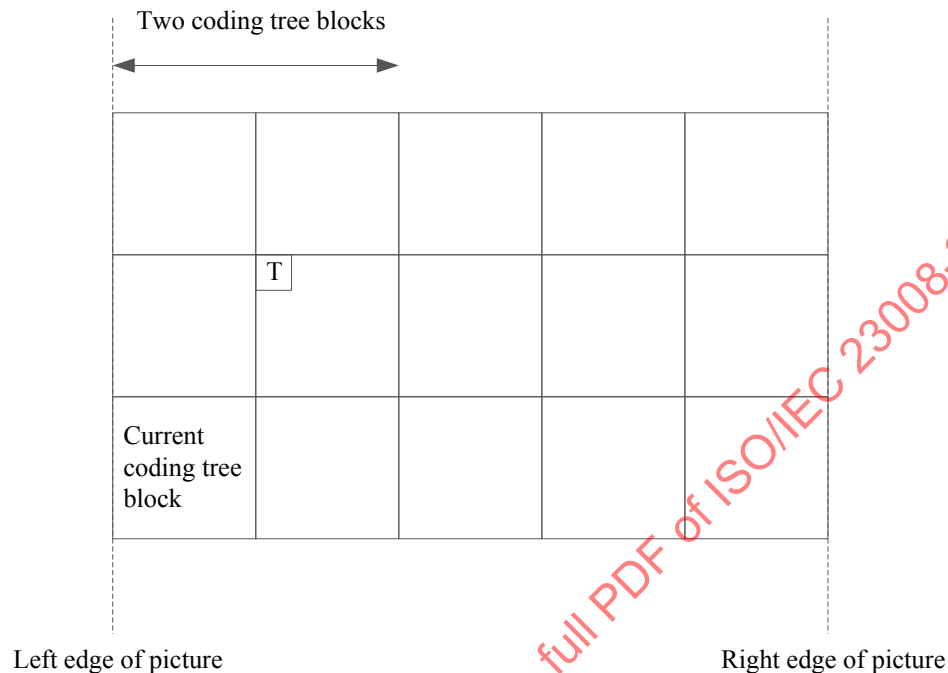

Figure 9-2 — Spatial neighbour T that is used to invoke the coding tree block availability derivation process relative to the current coding tree block (informative)

The context variables of the arithmetic decoding engine, Rice parameter initialization states, and palette predictor variables are initialized as follows:

- If the coding tree unit is the first coding tree unit in a tile, the following apply:
 - The initialization process for context variables is invoked as specified in 9.3.2.2.
 - The variables StatCoeff[k] are set equal to 0, for k in the range 0 to 3, inclusive.
 - The initialization process for palette predictor variables is invoked as specified in 9.3.2.3.
- Otherwise, if entropy_coding_sync_enabled_flag is equal to 1 and either CtbAddrInRs % PicWidthInCtbsY is equal to 0 or TileId[CtbAddrInTs] is not equal to TileId[CtbAddrRsToTs[CtbAddrInRs - 1]], the following apply:
 - The location (xNbT, yNbT) of the top-left luma sample of the spatial neighbouring block T (see Figure 9-2) is derived using the location (x0, y0) of the top-left luma sample of the current coding tree block as follows:

$$(xNbT, yNbT) = (x0 + CtbSizeY, y0 - CtbSizeY) \quad (9-3)$$
 - The availability derivation process for a block in z-scan order as specified in 6.4.1 is invoked with the location (xCurr, yCurr) set equal to (x0, y0) and the neighbouring location (xNbY, yNbY) set equal to (xNbT, yNbT) as inputs, and the output is assigned to availableFlagT.

ISO/IEC 23008-2:2017(E)

- The synchronization process for context variables, Rice parameter initialization states, and palette predictor variables is invoked as follows:
 - If availableFlagT is equal to 1, the synchronization process for context variables, Rice parameter initialization states, and palette predictor variables as specified in 9.3.2.5 is invoked with TableStateIdxWpp, TableMpsValWpp, TableStatCoeffWpp, PredictorPaletteSizeWpp, and TablePredictorPaletteEntriesWpp as inputs.
 - Otherwise, the following apply:
 - The initialization process for context variables is invoked as specified in 9.3.2.2.
 - The variables StatCoeff[k] are set equal to 0, for k in the range 0 to 3, inclusive.
 - The initialization process for palette predictor variables is invoked as specified in 9.3.2.3.
 - Otherwise, if CtbAddrInRs is equal to slice_segment_address and dependent_slice_segment_flag is equal to 1, the synchronization process for context variables and Rice parameter initialization states as specified in 9.3.2.5 is invoked with TableStateIdxDs, TableMpsValDs, TableStatCoeffDs, PredictorPaletteSizeDs, and TablePredictorPaletteEntriesDs as inputs.
- Otherwise, the following apply:
 - The initialization process for context variables is invoked as specified in 9.3.2.2.
 - The variables StatCoeff[k] are set equal to 0, for k in the range 0 to 3, inclusive.
 - The initialization process for palette predictor variables is invoked as specified in 9.3.2.3.

The initialization process for the arithmetic decoding engine is invoked as specified in 9.3.2.6.

The whole initialization process for a syntax element synEl is illustrated in the flowchart of Figure 9-3.

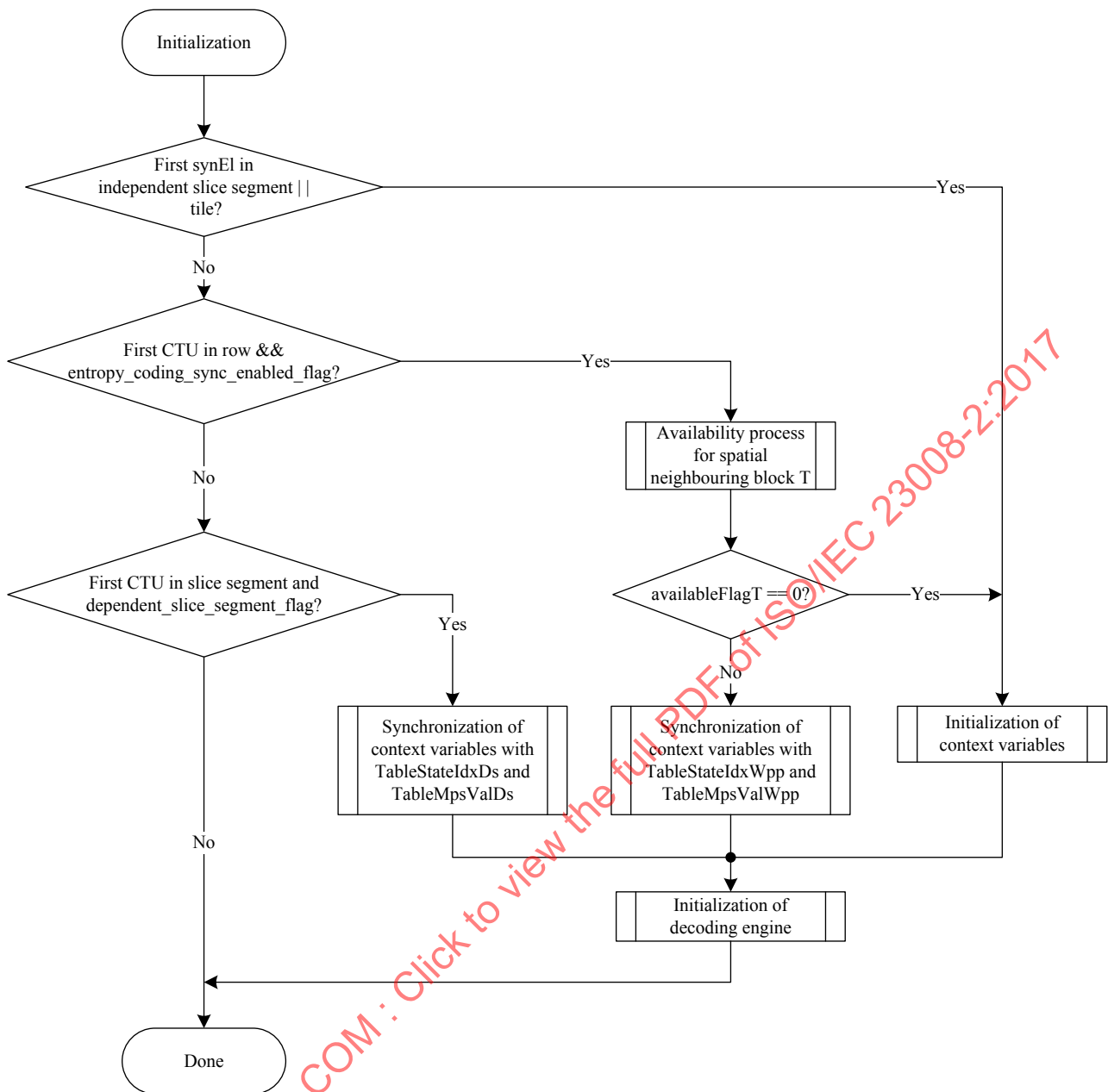

Figure 9-3 — CABAC initialization process (informative)

9.3.2.2 Initialization process for context variables

Outputs of this process are the initialized CABAC context variables indexed by ctxTable and ctxIdx.

Table 9-5 to Table 9-37 contain the values of the 8 bit variable `initValue` used in the initialization of context variables that are assigned to all syntax elements in 7.3.8.1 through 7.3.8.12, except `end_of_slice_segment_flag`, `end_of_subset_one_bit`, and `pcm_flag`.

For each context variable, the two variables `pStateIdx` and `valMps` are initialized.

NOTE 1 The variable `pStateIdx` corresponds to a probability state index and the variable `valMps` corresponds to the value of the most probable symbol as further described in 9.3.4.3.

ISO/IEC 23008-2:2017(E)

From the 8 bit table entry `initValue`, the two 4 bit variables `slopeIdx` and `offsetIdx` are derived as follows:

$$\begin{aligned} \text{slopeIdx} &= \text{initValue} \gg 4 \\ \text{offsetIdx} &= \text{initValue} \& 15 \end{aligned} \quad (9-4)$$

The variables `m` and `n`, used in the initialization of context variables, are derived from `slopeIdx` and `offsetIdx` as follows:

$$\begin{aligned} m &= \text{slopeIdx} * 5 - 45 \\ n &= (\text{offsetIdx} \ll 3) - 16 \end{aligned} \quad (9-5)$$

The two values assigned to `pStateIdx` and `valMps` for the initialization are derived from `SliceQpy`, which is derived in Formula (7-54). Given the variables `m` and `n`, the initialization is specified as follows:

$$\begin{aligned} \text{preCtxState} &= \text{Clip3}(1, 126, ((m * \text{Clip3}(0, 51, \text{SliceQp}_y)) \gg 4) + n) \\ \text{valMps} &= (\text{preCtxState} \leq 63) ? 0 : 1 \\ \text{pStateIdx} &= \text{valMps} ? (\text{preCtxState} - 64) : (63 - \text{preCtxState}) \end{aligned} \quad (9-6)$$

In Table 9-4, the `ctxIdx` for which initialization is needed for each of the three initialization types, specified by the variable `initType`, are listed. Also listed is the table number that includes the values of `initValue` needed for the initialization. For P and B slice types, the derivation of `initType` depends on the value of the `cabac_init_flag` syntax element. The variable `initType` is derived as follows:

$$\begin{aligned} &\text{if}(\text{slice_type} == 1) \\ &\quad \text{initType} = 0 \\ &\text{else if}(\text{slice_type} == P) \\ &\quad \text{initType} = \text{cabac_init_flag} ? 2 : 1 \\ &\text{else} \\ &\quad \text{initType} = \text{cabac_init_flag} ? 1 : 2 \end{aligned} \quad (9-7)$$

Table 9-4 — Association of `ctxIdx` and syntax elements for each `initType` in the initialization process

Syntax structure	Syntax element	ctxTable	initType		
			0	1	2
sao()	sao_merge_left_flag sao_merge_up_flag	Table 9-5	0	1	2
	sao_type_idx_luma sao_type_idx_chroma	Table 9-6	0	1	2
coding_quadtree()	split_cu_flag[][]	Table 9-7	0..2	3..5	6..8
coding_unit()	cu_transquant_bypass_flag	Table 9-8	0	1	2
	cu_skip_flag	Table 9-9		0..2	3..5
	palette_mode_flag[]	Table 9-38	0	1	2
	pred_mode_flag	Table 9-10		0	1
	part_mode	Table 9-11	0	1..4	5..8
	prev_intra_luma_pred_flag[][]	Table 9-12	0	1	2
	intra_chroma_pred_mode[][]	Table 9-13	0	1	2
prediction_unit()	rqt_root_cbf	Table 9-14		0	1
	merge_flag[][]	Table 9-15		0	1
	merge_idx[][]	Table 9-16		0	1
	inter_pred_idc[][]	Table 9-17		0..4	5..9

	ref_idx_l0[][], ref_idx_l1[][]	Table 9-18		0..1	2..3
	mvp_l0_flag[][], mvp_l1_flag[][]	Table 9-19		0	1
transform_tree()	split_transform_flag[][][]	Table 9-20	0..2	3..5	6..8
	cbf_luma[][][]	Table 9-21	0..1	2..3	4..5
	cbf_cb[][][], cbf_cr[][][]	Table 9-22	0..3 12	4..7 13	8..11 14
mvd_coding()	abs_mvd_greater0_flag[]	Table 9-23		0	2
	abs_mvd_greater1_flag[]	Table 9-23		1	3
cross_comp_pred()	log2_res_scale_abs_plus1[]	Table 9-36	0..7	8..15	16..23
	res_scale_sign_flag[]	Table 9-37	0..1	2..3	4..5
residual_coding()	transform_skip_flag[][][0]	Table 9-25	0	1	2
	transform_skip_flag[][][1] transform_skip_flag[][][2]	Table 9-25	3	4	5
	explicit_rdpdm_flag[][][0]	Table 9-32		0	1
	explicit_rdpdm_flag[][][1] explicit_rdpdm_flag[][][2]	Table 9-32		2	3
	explicit_rdpdm_dir_flag[][][0]	Table 9-33		0	1
	explicit_rdpdm_dir_flag[][][1] explicit_rdpdm_dir_flag[][][2]	Table 9-33		2	3
	last_sig_coeff_x_prefix	Table 9-26	0..17	18..35	36..53
	last_sig_coeff_y_prefix	Table 9-27	0..17	18..35	36..53
	coded_sub_block_flag[][]	Table 9-28	0..3	4..7	8..11
	sig_coeff_flag[][]	Table 9-29	0..41 126..127	42..83 128..129	84..125 130..131
	coeff_abs_level_greater1_flag[]	Table 9-30	0..23	24..47	48..71
	coeff_abs_level_greater2_flag[]	Table 9-31	0..5	6..11	12..17
	palette_coding()	palette_run_prefix	Table 9-40	0..7	8..15
copy_above_palette_indices_flag		Table 9-41	0	1	2
copy_above_indices_for_final_run_flag		Table 9-41	0	1	2
palette_transpose_flag		Table 9-42	0	1	2
delta_qp()	cu_qp_delta_abs	Table 9-24	0..1	2..3	4..5
chroma_qp_offset()	cu_chroma_qp_offset_flag	Table 9-34	0	1	2
	cu_chroma_qp_offset_idx	Table 9-35	0	1	2

NOTE 2 ctxTable equal to 0 and ctxIdx equal to 0 are associated with end_of_slice_segment_flag, end_of_subset_one_bit, and pcm_flag. The decoding process specified in 9.3.4.3.5 applies to ctxTable equal to 0 and ctxIdx equal to 0. This decoding process, however, may also be implemented by using the decoding process specified in 9.3.4.3.2. In this case, the initial values associated with ctxTable equal to 0 and ctxIdx equal to 0 are specified to be pStateIdx = 63 and valMps = 0, where pStateIdx = 63 represents a non-adapting probability state.

Table 9-5 — Values of initValue for ctxIdx of sao_merge_left_flag and sao_merge_up_flag

Initialization variable	ctxIdx of sao_merge_left_flag and sao_merge_up_flag		
	0	1	2
initValue	153	153	153

Table 9-6 — Values of initValue for ctxIdx of sao_type_idx_luma and sao_type_idx_chroma

Initialization variable	ctxIdx of sao_type_idx_luma and sao_type_idx_chroma		
	0	1	2
initValue	200	185	160

Table 9-7 — Values of initValue for ctxIdx of split_cu_flag

Initialization variable	ctxIdx of split_cu_flag								
	0	1	2	3	4	5	6	7	8
initValue	139	141	157	107	139	126	107	139	126

Table 9-8 — Values of initValue for ctxIdx of cu_transquant_bypass_flag

Initialization variable	ctxIdx of cu_transquant_bypass_flag		
	0	1	2
initValue	154	154	154

Table 9-9 — Values of initValue for ctxIdx of cu_skip_flag

Initialization variable	ctxIdx of cu_skip_flag					
	0	1	2	3	4	5
initValue	197	185	201	197	185	201

Table 9-10 — Values of initValue for ctxIdx of pred_mode_flag

Initialization variable	ctxIdx of pred_mode_flag	
	0	1
initValue	149	134

Table 9-11 — Values of initValue for ctxIdx of part_mode

Initialization variable	ctxIdx of part_mode								
	0	1	2	3	4	5	6	7	8
initValue	184	154	139	154	154	154	139	154	154

Table 9-12 — Values of initValue for ctxIdx of prev_intra_luma_pred_flag

Initialization variable	ctxIdx of prev_intra_luma_pred_flag		
	0	1	2
initValue	184	154	183

Table 9-13 — Values of initValue for ctxIdx of intra_chroma_pred_mode

Initialization variable	ctxIdx of intra_chroma_pred_mode		
	0	1	2
initValue	63	152	152

Table 9-14 — Values of initValue for ctxIdx of rqt_root_cbf

Initialization variable	ctxIdx of rqt_root_cbf	
	0	1
initValue	79	79

Table 9-15 — Value of initValue for ctxIdx of merge_flag

Initialization variable	ctxIdx of merge_flag	
	0	1
initValue	110	154

Table 9-16 — Values of initValue for ctxIdx of merge_idx

Initialization variable	ctxIdx of merge_idx	
	0	1
initValue	122	137

Table 9-17 — Values of initValue for ctxIdx of inter_pred_idc

Initialization variable	ctxIdx of inter_pred_idc									
	0	1	2	3	4	5	6	7	8	9
initValue	95	79	63	31	31	95	79	63	31	31

Table 9-18 — Values of initValue for ctxIdx of ref_idx_l0 and ref_idx_l1

Initialization variable	ctxIdx of ref_idx_l0 and ref_idx_l1			
	0	1	2	3
initValue	153	153	153	153

Table 9-19 — Values of initValue for ctxIdx of.mvp_l0_flag and.mvp_l1_flag

Initialization variable	ctxIdx of.mvp_l0_flag and.mvp_l1_flag	
	0	1
initValue	168	168

Table 9-20 — Values of initValue for ctxIdx of split_transform_flag

Initialization variable	ctxIdx of split_transform_flag								
	0	1	2	3	4	5	6	7	8
initValue	153	138	138	124	138	94	224	167	122

Table 9-21 — Values of initValue for ctxIdx of cbf_luma

Initialization variable	ctxIdx of cbf_luma					
	0	1	2	3	4	5
initValue	111	141	153	111	153	111

Table 9-22 — Values of initValue for ctxIdx of cbf_cb and cbf_cr

Initialization variable	ctxIdx of cbf_cb and cbf_cr														
	0	1	2	3	4	5	6	7	8	9	10	11	12	13	14
initValue	94	138	182	154	149	107	167	154	149	92	167	154	154	154	154

Table 9-23 — Values of initValue for ctxIdx of abs_mvd_greater0_flag and abs_mvd_greater1_flag

Initialization variable	ctxIdx of abs_mvd_greater0_flag and abs_mvd_greater1_flag			
	0	1	2	3
initValue	140	198	169	198

Table 9-24 — Values of initValue for ctxIdx of cu_qp_delta_abs

Initialization variable	ctxIdx of cu_qp_delta_abs					
	0	1	2	3	4	5
initValue	154	154	154	154	154	154

Table 9-25 — Values of initValue for ctxIdx of transform_skip_flag

Initialization variable	ctxIdx of transform_skip_flag					
	0	1	2	3	4	5
initValue	139	139	139	139	139	139

Table 9-26 — Values of initValue for ctxIdx of last_sig_coeff_x_prefix

Initialization variable	ctxIdx of last_sig_coeff_x_prefix																	
	0	1	2	3	4	5	6	7	8	9	10	11	12	13	14	15	16	17
initValue	110	110	124	125	140	153	125	127	140	109	111	143	127	111	79	108	123	63
	18	19	20	21	22	23	24	25	26	27	28	29	30	31	32	33	34	35
initValue	125	110	94	110	95	79	125	111	110	78	110	111	111	95	94	108	123	108
	36	37	38	39	40	41	42	43	44	45	46	47	48	49	50	51	52	53
initValue	125	110	124	110	95	94	125	111	111	79	125	126	111	111	79	108	123	93

Table 9-27 — Values of initValue for ctxIdx of last_sig_coeff_y_prefix

Initialization variable	ctxIdx of last_sig_coeff_y_prefix																	
	0	1	2	3	4	5	6	7	8	9	10	11	12	13	14	15	16	17
initValue	110	110	124	125	140	153	125	127	140	109	111	143	127	111	79	108	123	63
	18	19	20	21	22	23	24	25	26	27	28	29	30	31	32	33	34	35
initValue	125	110	94	110	95	79	125	111	110	78	110	111	111	95	94	108	123	108
	36	37	38	39	40	41	42	43	44	45	46	47	48	49	50	51	52	53
initValue	125	110	124	110	95	94	125	111	111	79	125	126	111	111	79	108	123	93

Table 9-28 — Values of initValue for ctxIdx of coded_sub_block_flag

Initialization variable	ctxIdx of coded_sub_block_flag											
	0	1	2	3	4	5	6	7	8	9	10	11
initValue	91	171	134	141	121	140	61	154	121	140	61	154

Table 9-29 — Values of initValue for ctxIdx of sig_coeff_flag

Initialization variable	ctxIdx of sig_coeff_flag															
	0	1	2	3	4	5	6	7	8	9	10	11	12	13	14	15
initValue	111	111	125	110	110	94	124	108	124	107	125	141	179	153	125	107
	16	17	18	19	20	21	22	23	24	25	26	27	28	29	30	31
initValue	125	141	179	153	125	107	125	141	179	153	125	140	139	182	182	152
	32	33	34	35	36	37	38	39	40	41	42	43	44	45	46	47
initValue	136	152	136	153	136	139	111	136	139	111	155	154	139	153	139	123
	48	49	50	51	52	53	54	55	56	57	58	59	60	61	62	63
initValue	123	63	153	166	183	140	136	153	154	166	183	140	136	153	154	166
	64	65	66	67	68	69	70	71	72	73	74	75	76	77	78	79
initValue	183	140	136	153	154	170	153	123	123	107	121	107	121	167	151	183
	80	81	82	83	84	85	86	87	88	89	90	91	92	93	94	95
initValue	140	151	183	140	170	154	139	153	139	123	123	63	124	166	183	140
	96	97	98	99	100	101	102	103	104	105	106	107	108	109	110	111
initValue	136	153	154	166	183	140	136	153	154	166	183	140	136	153	154	170
	112	113	114	115	116	117	118	119	120	121	122	123	124	125	126	127
initValue	153	138	138	122	121	122	121	167	151	183	140	151	183	140	141	111
	128	129	130	131												
initValue	140	140	140													

Table 9-30 — Values of initValue for ctxIdx of coeff_abs_level_greater1_flag

Initialization variable	ctxIdx of coeff_abs_level_greater1_flag															
	0	1	2	3	4	5	6	7	8	9	10	11	12	13	14	15
initValue	140	92	137	138	140	152	138	139	153	74	149	92	139	107	122	152
	16	17	18	19	20	21	22	23	24	25	26	27	28	29	30	31
initValue	140	179	166	182	140	227	122	197	154	196	196	167	154	152	167	182
	32	33	34	35	36	37	38	39	40	41	42	43	44	45	46	47
initValue	182	134	149	136	153	121	136	137	169	194	166	167	154	167	137	182
	48	49	50	51	52	53	54	55	56	57	58	59	60	61	62	63
initValue	154	196	167	167	154	152	167	182	182	134	149	136	153	121	136	122
	64	65	66	67	68	69	70	71								
initValue	169	208	166	167	154	152	167	182								

Table 9-31 — Values of initValue for ctxIdx of coeff_abs_level_greater2_flag

Initialization variable	ctxIdx of coeff_abs_level_greater2_flag								
	0	1	2	3	4	5	6	7	8
initValue	138	153	136	167	152	152	107	167	91
	9	10	11	12	13	14	15	16	17
initValue	122	107	167	107	167	91	107	107	167

Table 9-32 — Values of initValue for ctxIdx of explicit_rdpem_flag

Initialization variable	ctxIdx of explicit_rdpem_flag			
	0	1	2	3
initValue	139	139	139	139

Table 9-33 — Values of initValue for ctxIdx of explicit_rdpem_dir_flag

Initialization variable	ctxIdx of explicit_rdpem_dir_flag			
	0	1	2	3
initValue	139	139	139	139

Table 9-34 — Values of initValue for ctxIdx of cu_chroma_qp_offset_flag

Initialization variable	ctxIdx of cu_chroma_qp_offset_flag		
	0	1	2
initValue	154	154	154

Table 9-35 — Values of initValue for ctxIdx of cu_chroma_qp_offset_idx

Initialization variable	ctxIdx of cu_chroma_qp_offset_idx		
	0	1	2
initValue	154	154	154

Table 9-36 — Values of initValue for ctxIdx of log2_res_scale_abs_plus1

Initialization variable	ctxIdx of log2_res_scale_abs_plus1								
	0	1	2	3	4	5	6	7	8
initValue	154	154	154	154	154	154	154	154	154
	9	10	11	12	13	14	15	16	17
initValue	154	154	154	154	154	154	154	154	154
	18	19	20	21	22	23			
initValue	154	154	154	154	154	154			

Table 9-37 — Values of initValue for ctxIdx of res_scale_sign_flag

Initialization variable	ctxIdx of res_scale_sign_flag					
	0	1	2	3	4	5
initValue	154	154	154	154	154	154

Table 9-38 — Values of `initValue` for `ctxIdx` of `palette_mode_flag`

Initialization variable	ctxIdx of <code>palette_mode_flag</code>		
	0	1	2
<code>initValue</code>	154	154	154

Table 9-39 — Values of `initValue` for `ctxIdx` of `tu_residual_act_flag`

Initialization variable	ctxIdx of <code>tu_residual_act_flag</code>		
	0	1	2
<code>initValue</code>	154	154	154

Table 9-40 — Values of `initValue` for `ctxIdx` of `palette_run_prefix`

Initialization variable	ctxIdx of <code>palette_run_prefix</code>											
	0	1	2	3	4	5	6	7	8	9	10	11
<code>initValue</code>	154	154	154	154	154	154	154	154	154	154	154	154
	12	13	14	15	16	17	18	19	20	21	22	23
<code>initValue</code>	154	154	154	154	154	154	154	154	154	154	154	154

Table 9-41 — Values of `initValue` for `ctxIdx` of `copy_above_palette_indices_flag` and `copy_above_indices_for_final_run_flag`

Initialization variable	ctxIdx of <code>copy_above_palette_indices_flag</code> and <code>copy_above_indices_for_final_run_flag</code>		
	0	1	2
<code>initValue</code>	154	154	154

Table 9-42 — Values of `initValue` for `ctxIdx` of `palette_transpose_flag`

Initialization variable	ctxIdx of <code>palette_transpose_flag</code>		
	0	1	2
<code>initValue</code>	154	154	154

9.3.2.3 Initialization process for palette predictor entries

Outputs of this process are the initialized palette predictor variables `PredictorPaletteSize` and `PredictorPaletteEntries`.

The variable `numComps` is derived as follows:

$$\text{numComps} = (\text{ChromaArrayType} = 0) ? 1 : 3 \quad (9-8)$$

— If `pps_palette_predictor_initializer_present_flag` is equal to 1, the following apply:

— `PredictorPaletteSize` is set equal to `pps_num_palette_predictor_initializer`.

— The array `PredictorPaletteEntries` is derived as follows:

$$\begin{aligned} &\text{for}(\text{comp} = 0; \text{comp} < \text{numComps}; \text{comp}++) \\ &\quad \text{for}(\text{i} = 0; \text{i} < \text{PredictorPaletteSize}; \text{i}++) \quad (9-9) \\ &\quad \quad \text{PredictorPaletteEntries}[\text{comp}][\text{i}] = \text{pps_palette_predictor_initializers}[\text{comp}][\text{i}] \end{aligned}$$

ISO/IEC 23008-2:2017(E)

- Otherwise (`pps_palette_predictor_initializer_present_flag` is equal to 0), if `sps_palette_predictor_initializer_present_flag` is equal to 1, the following apply:
 - `PredictorPaletteSize` is set equal to `sps_num_palette_predictor_initializer_minus1` plus 1.
 - The array `PredictorPaletteEntries` is derived as follows:

```
for( comp = 0; comp < numComps; comp++ )  
    for( i = 0; i < PredictorPaletteSize; i++ )  
        PredictorPaletteEntries[ comp ][ i ] = sps_palette_predictor_initializers[ comp ][ i ]
```

(9-10)

- Otherwise (`pps_palette_predictor_initializer_present_flag` is equal to 0 and `sps_palette_predictor_initializer_present_flag` is equal to 0), `PredictorPaletteSize` is set equal to 0.

9.3.2.4 Storage process for context variables, Rice parameter initialization states, and palette predictor variables

Inputs to this process are

- the CABAC context variables indexed by `ctxTable` and `ctxIdx`,
- the Rice parameter initialization states indexed by `k`, and
- the palette predictor variables, `PredictorPaletteSize` and `PredictorPaletteEntries`.

Outputs of this process are

- the variables `tableStateSync` and `tableMPSSync` containing the values of the variables `pStateIdx` and `valMps` used in the initialization process of context variables and Rice parameter initialization states that are assigned to all syntax elements in 7.3.8.1 through 7.3.8.12, except `end_of_slice_segment_flag`, `end_of_subset_one_bit`, and `pcm_flag`,
- the variables `tableStatCoeffSync` containing the values of the variables `StatCoeff[k]` used in the initialization process of Rice parameter initialization states, and
- the variables `PredictorPaletteSizeSync` and `tablePredictorPaletteEntriesSync` containing the values used in the initialization process of palette predictor variables.

For each context variable, the corresponding entries `pStateIdx` and `valMps` of tables `tableStateSync` and `tableMPSSync` are initialized to the corresponding `pStateIdx` and `valMps`.

For each Rice parameter initialization state `k`, each entry of the table `tableStatCoeffSync` is initialized to the corresponding value of `StatCoeff[k]`.

For palette predictor variables, `PredictorPaletteSizeSync` is initialized to `PredictorPaletteSize`. For `tablePredictorPaletteEntriesSync`, each entry is initialized to the corresponding value of `PredictorPaletteEntries`.

The storage process for context variables is illustrated in the flowchart of Figure 9-4.

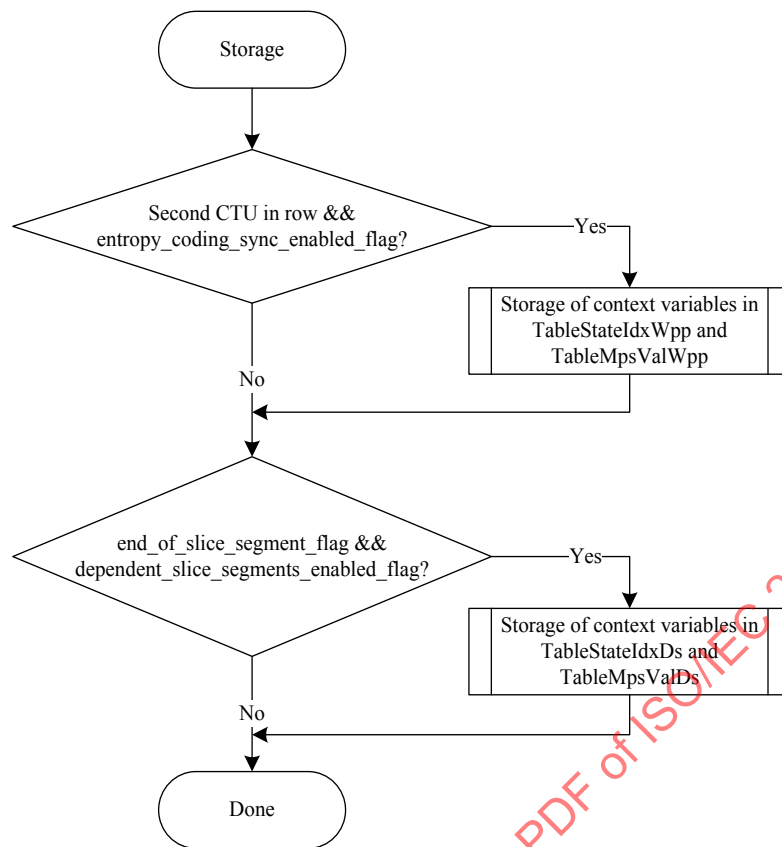

Figure 9-4 — Illustration of CABAC storage process (informative)

9.3.2.5 Synchronization process for context variables, Rice parameter initialization states, and palette predictor variables

Inputs to this process are

- the variables `tableStateSync` and `tableMPSSync` containing the values of the variables `pStateIdx` and `valMps` used in the storage process of context variables that are assigned to all syntax elements in 7.3.8.1 through 7.3.8.12, except `end_of_slice_segment_flag`, `end_of_subset_one_bit`, and `pcm_flag`,
- the variable `tableStatCoeffSync` containing the values of the variables `StatCoeff[k]` used in the storage process of Rice parameter initialization states, and
- the variables `PredictorPaletteSizeSync` and `tablePredictorPaletteEntriesSync` containing the values used in the storage process of palette predictor variables.

Outputs of this process are

- the initialized CABAC context variables indexed by `ctxTable` and `ctxIdx`,
- the initialized Rice parameter initialization states `StatCoeff` indexed by `k`, and
- the palette predictor variables, `PredictorPaletteSize` and `PredictorPaletteEntries`.

For each context variable, the corresponding context variables `pStateIdx` and `valMps` are initialized to the corresponding entries `pStateIdx` and `valMps` of tables `tableStateSync` and `tableMPSSync`.

For each Rice parameter initialization state, each variable `StatCoeff[k]` is initialized to the corresponding entry of table `tableStatCoeffSync`.

ISO/IEC 23008-2:2017(E)

For palette predictor variables, PredictorPaletteSize is initialized to PredictorPaletteSizeSync. For PredictorPaletteEntries, each entry is initialized to the corresponding value of tablePredictorPaletteEntriesSync.

9.3.2.6 Initialization process for the arithmetic decoding engine

Outputs of this process are the initialized decoding engine registers ivlCurrRange and ivlOffset both in 16 bit register precision.

The status of the arithmetic decoding engine is represented by the variables ivlCurrRange and ivlOffset. In the initialization procedure of the arithmetic decoding process, ivlCurrRange is set equal to 510 and ivlOffset is set equal to the value returned from read_bits(9) interpreted as a 9 bit binary representation of an unsigned integer with the most significant bit written first.

The bitstream shall not contain data that result in a value of ivlOffset being equal to 510 or 511.

NOTE The description of the arithmetic decoding engine in this document utilizes 16 bit register precision. However, a minimum register precision of 9 bits is required for storing the values of the variables ivlCurrRange and ivlOffset after invocation of the arithmetic decoding process (DecodeBin) as specified in 9.3.4.3. The arithmetic decoding process for a binary decision (DecodeDecision) as specified in 9.3.4.3.2 and the decoding process for a binary decision before termination (DecodeTerminate) as specified in 9.3.4.3.5 require a minimum register precision of 9 bits for the variables ivlCurrRange and ivlOffset. The bypass decoding process for binary decisions (DecodeBypass) as specified in 9.3.4.3.4 requires a minimum register precision of 10 bits for the variable ivlOffset and a minimum register precision of 9 bits for the variable ivlCurrRange.

9.3.3 Binarization process

9.3.3.1 General

Input to this process is a request for a syntax element.

Output of this process is the binarization of the syntax element.

Table 9-43 specifies the type of binarization process associated with each syntax element and corresponding inputs.

The specification of the truncated Rice (TR) binarization process, the k-th order Exp-Golomb (EGk) binarization process, limited k-th order Exp-Golomb (EGk) binarization process, the fixed-length (FL) binarization process, and the truncated binary binarization process are given in 9.3.3.2 through 9.3.3.6, respectively. Other binarizations are specified in 9.3.3.7 through 9.3.3.14.

Table 9-43 — Syntax elements and associated binarizations

Syntax structure	Syntax element	Binarization	
		Process	Input parameters
slice_segment_data()	end_of_slice_segment_flag	FL	cMax = 1
	end_of_subset_one_bit	FL	cMax = 1
sao()	sao_merge_left_flag	FL	cMax = 1
	sao_merge_up_flag	FL	cMax = 1
	sao_type_idx_luma	TR	cMax = 2, cRiceParam = 0
	sao_type_idx_chroma	TR	cMax = 2, cRiceParam = 0
	sao_offset_abs[][][]	TR	cMax = (1 << (Min(bitDepth, 10) - 5)) - 1, cRiceParam = 0
	sao_offset_sign[][][]	FL	cMax = 1
	sao_band_position[][][]	FL	cMax = 31

	sao_eo_class_luma	FL	cMax = 3
	sao_eo_class_chroma	FL	cMax = 3
coding_quadtree()	split_cu_flag[][]	FL	cMax = 1
coding_unit()	cu_transquant_bypass_flag	FL	cMax = 1
	cu_skip_flag	FL	cMax = 1
	palette_mode_flag	FL	cMax = 1
	pred_mode_flag	FL	cMax = 1
	part_mode	9.3.3.7	(xCb, yCb) = (x0, y0), log2CbSize
	pcm_flag[][]	FL	cMax = 1
	prev_intra_luma_pred_flag[][]	FL	cMax = 1
	mpm_idx[][]	TR	cMax = 2, cRiceParam = 0
	rem_intra_luma_pred_mode[][]	FL	cMax = 31
	intra_chroma_pred_mode[][]	9.3.3.8	-
	rqt_root_cbf	FL	cMax = 1
prediction_unit()	merge_flag[][]	FL	cMax = 1
	merge_idx[][]	TR	cMax = MaxNumMergeCand - 1, cRiceParam = 0
	inter_pred_idc[x0][y0]	9.3.3.9	nPbW, nPbH
	ref_idx_l0[][]	TR	cMax = num_ref_idx_l0_active_minus1, cRiceParam = 0
	mvp_l0_flag[][]	FL	cMax = 1
	ref_idx_l1[][]	TR	cMax = num_ref_idx_l1_active_minus1, cRiceParam = 0
	mvp_l1_flag[][]	FL	cMax = 1
transform_tree()	split_transform_flag[][][]	FL	cMax = 1
	cbf_luma[][][]	FL	cMax = 1
	cbf_cb[][][]	FL	cMax = 1
	cbf_cr[][][]	FL	cMax = 1
mvd_coding()	abs_mvd_greater0_flag[]	FL	cMax = 1
	abs_mvd_greater1_flag[]	FL	cMax = 1
	abs_mvd_minus2[]	EG1	-
	mvd_sign_flag[]	FL	cMax = 1
transform_unit()	tu_residual_act_flag	FL	cMax = 1
cross_comp_pred()	log2_res_scale_abs_plus1	TR	cMax = 4, cRiceParam = 0
	res_scale_sign_flag	FL	cMax = 1
residual_coding()	transform_skip_flag[][][]	FL	cMax = 1
	explicit_rdp_pcm_flag[][][]	FL	cMax = 1
	explicit_rdp_pcm_dir_flag[][][]	FL	cMax = 1
	last_sig_coeff_x_prefix	TR	cMax = (log2TrafoSize << 1) - 1, cRiceParam = 0

	last_sig_coeff_y_prefix	TR	$cMax = (\log_2 TrafoSize \ll 1) - 1$, $cRiceParam = 0$
	last_sig_coeff_x_suffix	FL	$cMax = (1 \ll ((last_sig_coeff_x_prefix \gg 1) - 1) - 1)$
	last_sig_coeff_y_suffix	FL	$cMax = (1 \ll ((last_sig_coeff_y_prefix \gg 1) - 1) - 1)$
	coded_sub_block_flag[][]	FL	$cMax = 1$
	sig_coeff_flag[][]	FL	$cMax = 1$
	coeff_abs_level_greater1_flag[]	FL	$cMax = 1$
	coeff_abs_level_greater2_flag[]	FL	$cMax = 1$
	coeff_abs_level_remaining[]	9.3.3.11	current sub-block scan index i , baseLevel
	coeff_sign_flag[]	FL	$cMax = 1$
palette_coding()	palette_predictor_run	EG0	-
	num_signalled_palette_entries	EG0	-
	new_palette_entries	FL	$cMax = cIdx = 0 ?$ $((1 \ll BitDepth_y) - 1) : ((1 \ll BitDepth_c) - 1)$
	palette_escape_val_present_flag	FL	$cMax = 1$
	num_palette_indices_minus1	9.3.3.14	MaxPaletteIndex
	palette_index_idc	9.3.3.13	MaxPaletteIndex
	copy_above_indices_for_final_run_flag	FL	$cMax = 1$
	palette_transpose_flag	FL	$cMax = 1$
	copy_above_palette_indices_flag	FL	$cMax = 1$
	palette_run_prefix	TR	$cMax = Floor(\log_2(PaletteMaxRun)) + 1$, $cRiceParam = 0$
	palette_run_suffix	TB	$cMax = (PrefixOffset \ll 1) >$ $PaletteMaxRun ?$ $(PaletteMaxRun - PrefixOffset) : (PrefixOffset - 1)$
	palette_escape_val	9.3.3.12	$cIdx$, $cu_transquant_bypass_flag$
delta_qp()	cu_qp_delta_abs	9.3.3.10	-
	cu_qp_delta_sign_flag	FL	$cMax = 1$
chroma_qp_offset()	cu_chroma_qp_offset_flag	FL	$cMax = 1$
	cu_chroma_qp_offset_idx	TR	$cMax =$ $chroma_qp_offset_list_len_minus1$, $cRiceParam = 0$

9.3.3.2 Truncated Rice (TR) binarization process

Input to this process is a request for a TR binarization, $cMax$, and $cRiceParam$.

Output of this process is the TR binarization associating each value $symbolVal$ with a corresponding bin string.

A TR bin string is a concatenation of a prefix bin string and, when present, a suffix bin string.

For the derivation of the prefix bin string, the following apply:

- The prefix value of symbolVal, prefixVal, is derived as follows:

$$\text{prefixVal} = \text{symbolVal} \gg \text{cRiceParam} \tag{9-11}$$

- The prefix of the TR bin string is specified as follows:

- If prefixVal is less than cMax >> cRiceParam, the prefix bin string is a bit string of length prefixVal + 1 indexed by binIdx. The bins for binIdx less than prefixVal are equal to 1. The bin with binIdx equal to prefixVal is equal to 0. Table 9-44 illustrates the bin strings of this unary binarization for prefixVal.
- Otherwise, the bin string is a bit string of length cMax >> cRiceParam with all bins being equal to 1.

Table 9-44 — Bin string of the unary binarization (informative)

prefixVal	Bin string					
0	0					
1	1	0				
2	1	1	0			
3	1	1	1	0		
4	1	1	1	1	0	
5	1	1	1	1	1	0
...						
binIdx	0	1	2	3	4	5

When cMax is greater than symbolVal and cRiceParam is greater than 0, the suffix of the TR bin string is present and it is derived as follows:

- The suffix value suffixVal is derived as follows:

$$\text{suffixVal} = \text{symbolVal} - ((\text{prefixVal}) \ll \text{cRiceParam}) \tag{9-12}$$

- The suffix of the TR bin string is specified by invoking the fixed-length (FL) binarization process as specified in 9.3.3.5 for suffixVal with a cMax value equal to (1 << cRiceParam) - 1.

NOTE For the input parameter cRiceParam = 0, the TR binarization is exactly a truncated unary binarization and it is always invoked with a cMax value equal to the largest possible value of the syntax element being decoded.

9.3.3.3 k-th order Exp-Golomb (EGk) binarization process

Inputs to this process is a request for an EGk binarization.

Output of this process is the EGk binarization associating each value symbolVal with a corresponding bin string.

The bin string of the EGk binarization process for each value symbolVal is specified as follows, where each call of the function put(X), with X being equal to 0 or 1, adds the binary value X at the end of the bin string:

```

absV = Abs( symbolVal )
stopLoop = 0
do
    if( absV >= ( 1 << k ) ) {

```

```

        put( 1 )
        absV = absV - ( 1 << k )
        k++
    } else {
        put( 0 )
        while( k-- )
            put( ( absV >> k ) & 1 )
        stopLoop = 1
    }
while( !stopLoop )

```

(9-13)

NOTE The specification for the k-th order Exp-Golomb (EGk) code uses 1's and 0's in reverse meaning for the unary part of the Exp-Golomb code of 0-th order as specified in 9.2.

9.3.3.4 Limited k-th order Exp-Golomb (EGk) binarization process

This process is only invoked when `extended_precision_processing_flag` is equal to 1.

Inputs to this process is a request for a limited EGk binarization, the Rice parameter `riceParam`, and the colour component `cIdx`.

Output of this process is the limited EGk binarization associating each value `symbolVal` with a corresponding bin string.

The variables `log2TransformRange` and `maxPrefixExtensionLength` are derived as follows:

$$\text{log2TransformRange} = \text{cIdx} == 0 ? \text{Max}(15, \text{BitDepth}_Y + 6) : \text{Max}(15, \text{BitDepth}_C + 6) \quad (9-14)$$

$$\text{maxPrefixExtensionLength} = 28 - \text{log2TransformRange} \quad (9-15)$$

The bin string of the limited EGk binarization process for each value `symbolVal` is specified as follows, where each call of the function `put(X)`, with X being equal to 0 or 1, adds the binary value X at the end of the bin string:

```

codeValue = symbolVal >> riceParam
PrefixExtensionLength = 0
while( ( PrefixExtensionLength < maxPrefixExtensionLength ) &&
        ( codeValue > ( ( 2 << PrefixExtensionLength ) - 2 ) ) ) {
    PrefixExtensionLength++
    put( 1 )
}
if( PrefixExtensionLength == maxPrefixExtensionLength )
    escapeLength = log2TransformRange
else {
    escapeLength = PrefixExtensionLength + riceParam
    put( 0 )
}
symbolVal = symbolVal - ( ( ( 1 << PrefixExtensionLength ) - 1 ) << riceParam )
while( ( escapeLength-- ) > 0 )
    put( ( symbolVal >> escapeLength ) & 1 )

```

(9-16)

9.3.3.5 Fixed-length (FL) binarization process

Inputs to this process are a request for a FL binarization and `cMax`.

Output of this process is the FL binarization associating each value `symbolVal` with a corresponding bin string.

FL binarization is constructed by using the `fixedLength`-bit unsigned integer bin string of the symbol value `symbolVal`, where `fixedLength = Ceil(Log2(cMax + 1))`. The indexing of bins for the FL

binarization is such that the binIdx = 0 relates to the most significant bit with increasing values of binIdx towards the least significant bit.

9.3.3.6 Truncated Binary (TB) binarization process

Input to this process is a request for a TB binarization for a syntax element with value synVal and cMax. Output of this process is the TB binarization of the syntax element. The bin string of the TB binarization process of a syntax element synVal is specified as follows:

$$\begin{aligned} n &= cMax + 1 \\ k &= \text{Floor}(\text{Log}_2(n)) \\ u &= (1 \ll (k + 1)) - n \end{aligned} \tag{9-17}$$

- If synVal is less than u, the TB bin string is derived by invoking the FL binarization process specified in 9.3.3.5 for synVal with a cMax value equal to $(1 \ll k) - 1$.
- Otherwise (synVal is greater than or equal to u), the TB bin string is derived by invoking the FL binarization process specified in 9.3.3.5 for $(synVal + u)$ with a cMax value equal to $(1 \ll (k + 1)) - 1$.

9.3.3.7 Binarization process for part_mode

Inputs to this process are a request for a binarization for the syntax element part_mode, a luma location (xCb, yCb), specifying the top-left sample of the current luma coding block relative to the top-left luma sample of the current picture, and a variable log2CbSize specifying the current luma coding block size.

Output of this process is the binarization of the syntax element.

The binarization for the syntax element part_mode is specified in Table 9-45 depending on the values of CuPredMode[xCb][yCb] and log2CbSize.

Table 9-45 — Binarization for part_mode

CuPredMode [xCb][yCb]	part_mode	PartMode	Bin string			
			log2CbSize > MinCbLog2SizeY		log2CbSize == MinCbLog2SizeY	
			amp_enabled_flag	amp_enable_d_flag	log2CbSize == 3	log2CbSize > 3
MODE_INTRA	0	PART_2Nx2N	-	-	1	1
	1	PART_NxN	-	-	0	0
MODE_INTER	0	PART_2Nx2N	1	1	1	1
	1	PART_2NxN	01	011	01	01
	2	PART_Nx2N	00	001	00	001
	3	PART_NxN	-	-	-	000
	4	PART_2NxnU	-	0100	-	-
	5	PART_2NxnD	-	0101	-	-
	6	PART_nLx2N	-	0000	-	-
7	PART_nRx2N	-	0001	-	-	

9.3.3.8 Binarization process for intra_chroma_pred_mode

Input to this process is a request for a binarization for the syntax element intra_chroma_pred_mode.

Output of this process is the binarization of the syntax element.

The binarization for the syntax element intra_chroma_pred_mode is specified in Table 9-46.

Table 9-46 — Binarization for intra_chroma_pred_mode

Value of intra_chroma_pred_mode	Bin string
4	0
0	100
1	101
2	110
3	111

9.3.3.9 Binarization process for inter_pred_idc

Inputs to this process are a request for a binarization for the syntax element `inter_pred_idc`, the current luma prediction block width `nPbW`, and the current luma prediction block height `nPbH`.

Output of this process is the binarization of the syntax element.

The binarization for the syntax element `inter_pred_idc` is specified in Table 9-47.

Table 9-47 — Binarization for inter_pred_idc

Value of inter_pred_idc	Name of inter_pred_idc	Bin string	
		(nPbW + nPbH) != 12	(nPbW + nPbH) == 12
0	PRED_L0	00	0
1	PRED_L1	01	1
2	PRED_BI	1	-

9.3.3.10 Binarization process for cu_qp_delta_abs

Input to this process is a request for a binarization for the syntax element `cu_qp_delta_abs`.

Output of this process is the binarization of the syntax element.

The binarization of the syntax element `cu_qp_delta_abs` is a concatenation of a prefix bin string and (when present) a suffix bin string.

For the derivation of the prefix bin string, the following apply:

- The prefix value of `cu_qp_delta_abs`, `prefixVal`, is derived as follows:

$$\text{prefixVal} = \text{Min}(\text{cu_qp_delta_abs}, 5) \tag{9-18}$$

- The prefix bin string is specified by invoking the TR binarization process as specified in 9.3.3.2 for `prefixVal` with `cMax = 5` and `cRiceParam = 0`.

When `prefixVal` is greater than 4, the suffix bin string is present and it is derived as follows:

- The suffix value of `cu_qp_delta_abs`, `suffixVal`, is derived as follows:

$$\text{suffixVal} = \text{cu_qp_delta_abs} - 5 \tag{9-19}$$

- The suffix bin string is specified by invoking the k-th order EGk binarization process as specified in 9.3.3.3 for `suffixVal` with the Exp-Golomb order `k` set equal to 0.

9.3.3.11 Binarization process for coeff_abs_level_remaining[]

Input to this process is a request for a binarization for the syntax element `coeff_abs_level_remaining[n]`, the current sub-block scan index `i`, `baseLevel`, the colour component

$cIdx$, and the luma location ($x0$, $y0$) specifying the top-left sample of the current luma transform block relative to the top-left luma sample of the picture.

Output of this process is the binarization of the syntax element.

Depending on the value of `persistent_rice_adaptation_enabled_flag`, the following apply:

- If `persistent_rice_adaptation_enabled_flag` is equal to 0, the variable `initRiceValue` is set equal to 0.
- Otherwise (`persistent_rice_adaptation_enabled_flag` is equal to 1), the following applies:
 - The variable `sbType` is derived as follows:
 - If `transform_skip_flag[x0][y0][cIdx]` is equal to 0, and `cu_transquant_bypass_flag` is equal to 0, the following applies:

$$sbType = 2 * (cIdx == 0 ? 1 : 0) \quad (9-20)$$

- Otherwise, the following applies:

$$sbType = 2 * (cIdx == 0 ? 1 : 0) + 1 \quad (9-21)$$

- The variable `initRiceValue` is derived as follows:

$$initRiceValue = StatCoeff[sbType] / 4 \quad (9-22)$$

- If this process is invoked for the first time for the current sub-block scan index i , `StatCoeff[sbType]` is modified as follows:

$$\begin{aligned} & \text{if}(\text{coeff_abs_level_remaining}[n] \geq (3 \ll (\text{StatCoeff}[sbType] / 4))) \\ & \quad \text{StatCoeff}[sbType] ++ \\ & \text{else if}(2 * \text{coeff_abs_level_remaining}[n] < (1 \ll (\text{StatCoeff}[sbType] / 4)) \&\& \\ & \quad \text{StatCoeff}[sbType] > 0) \\ & \quad \text{StatCoeff}[sbType] -- \end{aligned} \quad (9-23)$$

The variables `cLastAbsLevel` and `cLastRiceParam` are derived as follows:

- If this process is invoked for the first time for the current sub-block scan index i , `cLastAbsLevel` is set equal to 0 and `cLastRiceParam` is set equal to `initRiceValue`.
- Otherwise (this process is not invoked for the first time for the current sub-block scan index i), `cLastAbsLevel` and `cLastRiceParam` are set equal to the values of `cAbsLevel` and `cRiceParam`, respectively, that have been derived during the last invocation of the binarization process for the syntax element `coeff_abs_level_remaining[n]` as specified in this subclause.

The variable `cAbsLevel` is set equal to `baseLevel + coeff_abs_level_remaining[n]`.

The variable `cRiceParam` is derived from `cLastAbsLevel` and `cLastRiceParam` as follows:

- If `persistent_rice_adaptation_enabled_flag` is equal to 0, the following applies:

$$cRiceParam = \text{Min}(cLastRiceParam + (cLastAbsLevel > (3 * (1 \ll cLastRiceParam)) ? 1 : 0), 4) \quad (9-24)$$

- Otherwise (`persistent_rice_adaptation_enabled_flag` is equal to 1), the following applies:

$$cRiceParam = cLastRiceParam + (cLastAbsLevel > (3 * (1 \ll cLastRiceParam)) ? 1 : 0) \quad (9-25)$$

The variable `cMax` is derived from `cRiceParam` as:

$$cMax = 4 \ll cRiceParam \quad (9-26)$$

ISO/IEC 23008-2:2017(E)

The binarization of the syntax element `coeff_abs_level_remaining[n]` is a concatenation of a prefix bin string and (when present) a suffix bin string.

For the derivation of the prefix bin string, the following apply:

- The prefix value of `coeff_abs_level_remaining[n]`, `prefixVal`, is derived as follows:

$$\text{prefixVal} = \text{Min}(\text{cMax}, \text{coeff_abs_level_remaining}[n]) \quad (9-27)$$

- The prefix bin string is specified by invoking the TR binarization process as specified in 9.3.3.2 for `prefixVal` with the variables `cMax` and `cRiceParam` as inputs.

When the prefix bin string is equal to the bit string of length 4 with all bits equal to 1, the suffix bin string is present and it is derived as follows:

- The suffix value of `coeff_abs_level_remaining[n]`, `suffixVal`, is derived as follows:

$$\text{suffixVal} = \text{coeff_abs_level_remaining}[n] - \text{cMax} \quad (9-28)$$

- If `extended_precision_processing_flag` is equal to 0, the suffix bin string is specified by invoking the k -th order EGk binarization process as specified in 9.3.3.3 for the binarization of `suffixVal` with the Exp-Golomb order k set equal to `cRiceParam + 1`.
- Otherwise (`extended_precision_processing_flag` is equal to 1), the suffix bin string is specified by invoking the limited k -th order EGk binarization process as specified in 9.3.3.4 for the binarization of `suffixVal` with the variable `riceParam` set equal to `cRiceParam + 1` and the colour component `cIdx`.

9.3.3.12 Binarization process for `palette_escape_val`

Input to this process is a request for a binarization for the syntax element `palette_escape_val`, `cu_transquant_bypass_flag` and colour component index `cIdx`.

Output of this process is the binarization of `palette_escape_val`.

The variable `bitDepth` is derived as follows:

$$\text{bitDepth} = (\text{cIdx} = 0) ? \text{BitDepth}_Y : \text{BitDepth}_C \quad (9-29)$$

The binarization of `palette_escape_val` is derived as follows:

- If `cu_transquant_bypass_flag` is equal to 1, the binarization of `palette_escape_val` is derived by invoking the FL binarization process specified in 9.3.3.5 with the input parameter set to $(1 \ll \text{bitdepth}) - 1$.
- Otherwise (`cu_transquant_bypass_flag` is equal to 0), the binarization of `palette_escape_val` is derived by invoking the k -th order Exp-Golomb binarization process specified in 9.3.3.3 with k set equal to 3.

9.3.3.13 Binarization process for `palette_index_idc`

Input to this process is a request for a binarization for the syntax element `palette_index_idc` and the variable `MaxPaletteIndex`.

Output of this process is the binarization of the syntax element.

The variable `cMax` is derived as follows:

- If this process is invoked for the first time for the current block, `cMax` is set equal to `MaxPaletteIndex`.

- Otherwise (this process is not invoked for the first time for the current block), $cMax$ is set equal to $MaxPaletteIndex$ minus 1.

The binarization for the `palette_index_idc` is derived by invoking the TB binarization process specified in 9.3.3.6 with $cMax$.

9.3.3.14 Binarization process for `num_palette_indices_minus1`

Input to this process is a request for a binarization for the syntax element `num_palette_indices_minus1`, and $MaxPaletteIndex$.

Output of this process is the binarization of the syntax element.

The variable $cRiceParam$ is derived as follows:

$$cRiceParam = 3 + ((MaxPaletteIndex + 1) \gg 3) \quad (9-30)$$

The variable $cMax$ is derived from $cRiceParam$ as:

$$cMax = 4 \ll cRiceParam \quad (9-31)$$

The binarization of the syntax element `num_palette_indices_minus1` is a concatenation of a prefix bin string and (when present) a suffix bin string.

For the derivation of the prefix bin string, the following apply:

- The prefix value of `num_palette_indices_minus1`, $prefixVal$, is derived as follows:

$$prefixVal = \text{Min}(cMax, num_palette_indices_minus1) \quad (9-32)$$

- The prefix bin string is specified by invoking the TR binarization process as specified in 9.3.3.2 for $prefixVal$ with the variables $cMax$ and $cRiceParam$ as inputs.

When the prefix bin string is equal to the bit string of length 4 with all bits equal to 1, the suffix bin string is present and it is derived as follows:

- The suffix value of `num_palette_indices_minus1`, $suffixVal$, is derived as follows:

$$suffixVal = num_palette_indices_minus1 - cMax \quad (9-33)$$

- The suffix bin string is specified by invoking the k -th order EG k binarization process as specified in 9.3.3.3 for the binarization of $suffixVal$ with the Exp-Golomb order k set equal to $cRiceParam + 1$.

9.3.4 Decoding process flow

9.3.4.1 General

Inputs to this process are all bin strings of the binarization of the requested syntax element as specified in 9.3.3.

Output of this process is the value of the syntax element.

This process specifies how each bin of a bin string is parsed for each syntax element. After parsing each bin, the resulting bin string is compared to all bin strings of the binarization of the syntax element and the following apply:

- If the bin string is equal to one of the bin strings, the corresponding value of the syntax element is the output.
- Otherwise (the bin string is not equal to one of the bin strings), the next bit is parsed.

ISO/IEC 23008-2:2017(E)

While parsing each bin, the variable `binIdx` is incremented by 1 starting with `binIdx` being set equal to 0 for the first bin.

The parsing of each bin is specified by the following two ordered steps:

1. The derivation process for `ctxTable`, `ctxIdx`, and `bypassFlag` as specified in 9.3.4.2 is invoked with `binIdx` as input and `ctxTable`, `ctxIdx`, and `bypassFlag` as outputs.
2. The arithmetic decoding process as specified in 9.3.4.3 is invoked with `ctxTable`, `ctxIdx`, and `bypassFlag` as inputs and the value of the bin as output.

9.3.4.2 Derivation process for `ctxTable`, `ctxIdx` and `bypassFlag`

9.3.4.2.1 General

Input to this process is the position of the current bin within the bin string, `binIdx`.

Outputs of this process are `ctxTable`, `ctxIdx`, and `bypassFlag`.

The values of `ctxTable`, `ctxIdx`, and `bypassFlag` are derived as follows based on the entries for `binIdx` of the corresponding syntax element in Table 9-48:

- If the entry in Table 9-48 is not equal to "bypass", "terminate", and "na", the values of `binIdx` are decoded by invoking the `DecodeDecision` process as specified in 9.3.4.3.2 and the following apply:
 - `ctxTable` is specified in Table 9-4.
 - The variable `ctxInc` is specified by the corresponding entry in Table 9-48 and when more than one value is listed in Table 9-48 for a `binIdx`, the assignment process for `ctxInc` for that `binIdx` is further specified in the clauses given in parenthesis.
 - The variable `ctxIdxOffset` is specified by the lowest value of `ctxIdx` in Table 9-4 depending on the current value of `initType`.
 - `ctxIdx` is set equal to the sum of `ctxInc` and `ctxIdxOffset`.
 - `bypassFlag` is set equal to 0.
- Otherwise, if the entry in Table 9-48 is equal to "bypass", the values of `binIdx` are decoded by invoking the `DecodeBypass` process as specified in 9.3.4.3.4 and the following apply:
 - `ctxTable` is set equal to 0.
 - `ctxIdx` is set equal to 0.
 - `bypassFlag` is set equal to 1.
- Otherwise, if the entry in Table 9-48 is equal to "terminate", the values of `binIdx` are decoded by invoking the `DecodeTerminate` process as specified in 9.3.4.3.5 and the following apply:
 - `ctxTable` is set equal to 0.
 - `ctxIdx` is set equal to 0.
 - `bypassFlag` is set equal to 0.
- Otherwise (the entry in Table 9-48 is equal to "na"), the values of `binIdx` do not occur for the corresponding syntax element.

Table 9-48 — Assignment of ctxInc to syntax elements with context coded bins

Syntax element	binIdx					
	0	1	2	3	4	>=5
end_of_slice_segment_flag	terminate	na	na	na	na	na
end_of_subset_one_bit	terminate	na	na	na	na	na
sao_merge_left_flag	0	na	na	na	na	na
sao_merge_up_flag	0	na	na	na	na	na
sao_type_idx_luma	0	bypass	na	na	na	na
sao_type_idx_chroma	0	bypass	na	na	na	na
sao_offset_abs[][][]	bypass	bypass	bypass	bypass	bypass	na
sao_offset_sign[][][]	bypass	na	na	na	na	na
sao_band_position[][][]	bypass	bypass	bypass	bypass	bypass	bypass
sao_eo_class_luma	bypass	bypass	bypass	na	na	na
sao_eo_class_chroma	bypass	bypass	bypass	na	na	na
split_cu_flag[][]	0, 1, 2 (9.3.4.2.2)	na	na	na	na	na
cu_transquant_bypass_flag	0	na	na	na	na	na
cu_skip_flag	0, 1, 2 (9.3.4.2.2)	na	na	na	na	na
palette_mode_flag	0	na	na	na	na	na
pred_mode_flag	0	na	na	na	na	na
part_mode log2CbSize = MinCbLog2SizeY	0	1	2	bypass	na	na
part_mode log2CbSize > MinCbLog2SizeY	0	1	3	bypass	na	na
pcm_flag[][]	terminate	na	na	na	na	na
prev_intra_luma_pred_flag[][]	0	na	na	na	na	na
mpm_idx[][]	bypass	bypass	na	na	na	na
rem_intra_luma_pred_mode[][]	bypass	bypass	bypass	bypass	bypass	na
intra_chroma_pred_mode[][]	0	bypass	bypass	na	na	na
rqt_root_cbf	0	na	na	na	na	na
tu_residual_act_flag	0	na	na	na	na	na
merge_flag[][]	0	na	na	na	na	na
merge_idx[][]	0	bypass	bypass	bypass	na	na
inter_pred_idc[x0][y0]	(nPbW + nPbH) != 12 ? CtDepth[x0][y0] : 4	4	na	na	na	na
ref_idx_l0[][]	0	1	bypass	bypass	bypass	bypass
ref_idx_l1[][]	0	1	bypass	bypass	bypass	bypass
mvp_l0_flag[][]	0	na	na	na	na	na

mvp_l1_flag[][]	0	na	na	na	na	na
split_transform_flag[][][]	$5 - \log_2 \text{TrafoSize}$	na	na	na	na	na
cbf_cb[][][]	trafoDepth	na	na	na	na	na
cbf_cr[][][]	trafoDepth	na	na	na	na	na
cbf_luma[][][]	trafoDepth == 0 ? 1 : 0	na	na	na	na	na
abs_mvd_greater0_flag[]	0	na	na	na	na	na
abs_mvd_greater1_flag[]	0	na	na	na	na	na
abs_mvd_minus2[]	bypass	bypass	bypass	bypass	bypass	bypass
mvd_sign_flag[]	bypass	na	na	na	na	na
log2_res_scale_abs_plus1[c]	$4 * c + 0$	$4 * c + 1$	$4 * c + 2$	$4 * c + 3$	na	na
res_scale_sign_flag[c]	C	na	na	na	na	na
transform_skip_flag[][][]	0	na	na	na	na	na
explicit_rdpem_flag[][][]	0	na	na	na	na	na
explicit_rdpem_dir_flag[][][]	0	na	na	na	na	na
last_sig_coeff_x_prefix	0..17 (9.3.4.2.3)					
last_sig_coeff_y_prefix	0..17 (9.3.4.2.3)					
last_sig_coeff_x_suffix	bypass	bypass	bypass	bypass	bypass	bypass
last_sig_coeff_y_suffix	bypass	bypass	bypass	bypass	bypass	bypass
coded_sub_block_flag[][]	0..3 (9.3.4.2.4)	na	na	na	na	na
sig_coeff_flag[][]	0..43 (9.3.4.2.5)	na	na	na	na	na
coeff_abs_level_greater1_flag[]	0..23 (9.3.4.2.6)	na	na	na	na	na
coeff_abs_level_greater2_flag[]	0..5 (9.3.4.2.7)	na	na	na	na	na
coeff_abs_level_remaining[]	bypass	bypass	bypass	bypass	bypass	bypass
coeff_sign_flag[]	bypass	na	na	na	na	na
palette_predictor_run	bypass	bypass	bypass	bypass	bypass	bypass
num_signalled_palette_entries	bypass	bypass	bypass	bypass	bypass	bypass
new_palette_entries	bypass	bypass	bypass	bypass	bypass	bypass
palette_escape_val_present_flag	bypass	na	na	na	na	na
palette_transpose_flag	0	na	na	na	na	na
num_palette_indices_minus1	bypass	bypass	bypass	bypass	bypass	bypass
palette_index_idc	bypass	bypass	bypass	bypass	bypass	bypass
copy_above_palette_indices_flag and copy_above_indices_for_final_run_flag	0	na	na	na	na	na
palette_run_prefix	0..7 (9.3.4.2.8)					
palette_run_suffix	bypass	bypass	bypass	bypass	bypass	bypass

palette_escape_val	bypass	bypass	bypass	bypass	bypass	bypass
cu_qp_delta_abs	0	1	1	1	1	bypass
cu_qp_delta_sign_flag	bypass	na	na	na	na	na
cu_chroma_qp_offset_flag	0	na	na	na	na	na
cu_chroma_qp_offset_idx	0	0	0	0	0	na

9.3.4.2.2 Derivation process of ctxInc using left and above syntax elements

Input to this process is the luma location (x_0, y_0) specifying the top-left luma sample of the current luma block relative to the top-left sample of the current picture.

Output of this process is ctxInc.

The location (x_{NbL}, y_{NbL}) is set equal to ($x_0 - 1, y_0$) and the variable availableL, specifying the availability of the block located directly to the left of the current block, is derived by invoking the availability derivation process for a block in z-scan order as specified in 6.4.1 with the location (x_{Curr}, y_{Curr}) set equal to (x_0, y_0) and the neighbouring location (x_{NbY}, y_{NbY}) set equal to (x_{NbL}, y_{NbL}) as inputs, and the output is assigned to availableL.

The location (x_{NbA}, y_{NbA}) is set equal to ($x_0, y_0 - 1$) and the variable availableA specifying the availability of the coding block located directly above the current block, is derived by invoking the availability derivation process for a block in z-scan order as specified in 6.4.1 with the location (x_{Curr}, y_{Curr}) set equal to (x_0, y_0) and the neighbouring location (x_{NbY}, y_{NbY}) set equal to (x_{NbA}, y_{NbA}) as inputs, and the output is assigned to availableA.

The assignment of ctxInc for the syntax elements split_cu_flag[x_0][y_0] and cu_skip_flag[x_0][y_0] is specified in Table 9-49.

Table 9-49 — Specification of ctxInc using left and above syntax elements

Syntax element	condL	condA	ctxInc
split_cu_flag[x_0][y_0]	$CtDepth[x_{NbL}][y_{NbL}] > cqtDepth$	$CtDepth[x_{NbA}][y_{NbA}] > cqtDepth$	(condL && availableL) + (condA && availableA)
cu_skip_flag[x_0][y_0]	cu_skip_flag[$x_{NbL}][y_{NbL}]$	cu_skip_flag[$x_{NbA}][y_{NbA}]$	(condL && availableL) + (condA && availableA)

9.3.4.2.3 Derivation process of ctxInc for the syntax elements last_sig_coeff_x_prefix and last_sig_coeff_y_prefix

Inputs to this process are the variable binIdx, the colour component index cIdx, and the transform block size log2TrafoSize.

Output of this process is the variable ctxInc.

The variables ctxOffset and ctxShift are derived as follows:

- If cIdx is equal to 0, ctxOffset is set equal to $3 * (\log_2TrafoSize - 2) + ((\log_2TrafoSize - 1) \gg 2)$ and ctxShift is set equal to $(\log_2TrafoSize + 1) \gg 2$.
- Otherwise (cIdx is greater than 0), ctxOffset is set equal to 15 and ctxShift is set equal to $\log_2TrafoSize - 2$.

The variable ctxInc is derived as follows:

$$ctxInc = (binIdx \gg ctxShift) + ctxOffset \quad (9-34)$$

9.3.4.2.4 Derivation process of ctxInc for the syntax element coded_sub_block_flag

Inputs to this process are the colour component index cIdx, the current sub-block scan location (xS, yS), the previously decoded bins of the syntax element coded_sub_block_flag, and the transform block size log2TrafoSize.

Output of this process is the variable ctxInc.

The variable csbfCtx is derived using the current location (xS, yS), two previously decoded bins of the syntax element coded_sub_block_flag in scan order, and the transform block size log2TrafoSize, as follows:

- csbfCtx is initialized with 0 as follows:

$$\text{csbfCtx} = 0 \tag{9-35}$$

- When xS is less than $(1 \ll (\log_2\text{TrafoSize} - 2)) - 1$, csbfCtx is modified as follows:

$$\text{csbfCtx} += \text{coded_sub_block_flag}[\text{xS} + 1][\text{yS}] \tag{9-36}$$

- When yS is less than $(1 \ll (\log_2\text{TrafoSize} - 2)) - 1$, csbfCtx is modified as follows:

$$\text{csbfCtx} += \text{coded_sub_block_flag}[\text{xS}][\text{yS} + 1] \tag{9-37}$$

The context index increment ctxInc is derived using the colour component index cIdx and csbfCtx as follows:

- If cIdx is equal to 0, ctxInc is derived as follows:

$$\text{ctxInc} = \text{Min}(\text{csbfCtx}, 1) \tag{9-38}$$

- Otherwise (cIdx is greater than 0), ctxInc is derived as follows:

$$\text{ctxInc} = 2 + \text{Min}(\text{csbfCtx}, 1) \tag{9-39}$$

9.3.4.2.5 Derivation process of ctxInc for the syntax element sig_coeff_flag

Inputs to this process are the colour component index cIdx, the luma location (x0, y0) specifying the top-left sample of the current transform block relative to the top-left sample of the current picture, the current coefficient scan location (xC, yC), the scan order index scanIdx, and the transform block size log2TrafoSize.

Output of this process is the variable ctxInc.

The variable sigCtx depends on the current location (xC, yC), the colour component index cIdx, the value of transform_skip_flag, the value of cu_transquant_bypass_flag, the transform block size, and previously decoded bins of the syntax element coded_sub_block_flag. For the derivation of sigCtx, the following apply:

- If transform_skip_context_enabled_flag is equal to 1 and either or both transform_skip_flag[x0][y0][cIdx] is equal to 1 or cu_transquant_bypass_flag is equal to 1, sigCtx is derived as follows:

$$\text{sigCtx} = (\text{cIdx} = 0) ? 42 : 16 \tag{9-40}$$

- Otherwise, if log2TrafoSize is equal to 2, sigCtx is derived using ctxIdxMap[] specified in Table 9-50 as follows:

$$\text{sigCtx} = \text{ctxIdxMap}[(\text{yC} \ll 2) + \text{xC}] \tag{9-41}$$

- Otherwise, if $x_C + y_C$ is equal to 0, sigCtx is derived as follows:

$$\text{sigCtx} = 0 \quad (9-42)$$

- Otherwise, sigCtx is derived using previous values of $\text{coded_sub_block_flag}$ as follows:

- The sub-block location (x_S, y_S) is set equal to $(x_C \gg 2, y_C \gg 2)$.

- The variable prevCsbF is set equal to 0.

- When x_S is less than $(1 \ll (\log_2 \text{TrafoSize} - 2)) - 1$, the following applies:

$$\text{prevCsbF} += \text{coded_sub_block_flag}[x_S + 1][y_S] \quad (9-43)$$

- When y_S is less than $(1 \ll (\log_2 \text{TrafoSize} - 2)) - 1$, the following applies:

$$\text{prevCsbF} += (\text{coded_sub_block_flag}[x_S][y_S + 1] \ll 1) \quad (9-44)$$

- The inner sub-block location (x_P, y_P) is set equal to $(x_C \& 3, y_C \& 3)$.

- The variable sigCtx is derived as follows:

- If prevCsbF is equal to 0, the following applies:

$$\text{sigCtx} = (x_P + y_P == 0) ? 2 : (x_P + y_P < 3) ? 1 : 0 \quad (9-45)$$

- Otherwise, if prevCsbF is equal to 1, the following applies:

$$\text{sigCtx} = (y_P == 0) ? 2 : (y_P == 1) ? 1 : 0 \quad (9-46)$$

- Otherwise, if prevCsbF is equal to 2, the following applies:

$$\text{sigCtx} = (x_P == 0) ? 2 : (x_P == 1) ? 1 : 0 \quad (9-47)$$

- Otherwise (prevCsbF is equal to 3), the following applies:

$$\text{sigCtx} = 2 \quad (9-48)$$

- The variable sigCtx is modified as follows:

- If cIdx is equal to 0, the following apply:

- When $(x_S + y_S)$ is greater than 0, the following applies:

$$\text{sigCtx} += 3 \quad (9-49)$$

- The variable sigCtx is modified as follows:

- If $\log_2 \text{TrafoSize}$ is equal to 3, the following applies:

$$\text{sigCtx} += (\text{scanIdx} == 0) ? 9 : 15 \quad (9-50)$$

- Otherwise, the following applies:

$$\text{sigCtx} += 21 \quad (9-51)$$

- Otherwise (cIdx is greater than 0), the following applies:

- If $\log_2 \text{TrafoSize}$ is equal to 3, the following applies:

$$\text{sigCtx} += 9 \tag{9-52}$$

— Otherwise, the following applies:

$$\text{sigCtx} += 12 \tag{9-53}$$

The context index increment ctxInc is derived using the colour component index cIdx and sigCtx as follows:

— If cIdx is equal to 0, ctxInc is derived as follows:

$$\text{ctxInc} = \text{sigCtx} \tag{9-54}$$

— Otherwise (cIdx is greater than 0), ctxInc is derived as follows:

$$\text{ctxInc} = 27 + \text{sigCtx} \tag{9-55}$$

Table 9-50 — Specification of $\text{ctxIdxMap}[i]$

i	0	1	2	3	4	5	6	7	8	9	10	11	12	13	14
$\text{ctxIdxMap}[i]$	0	1	4	5	2	3	4	5	6	6	8	8	7	7	8

9.3.4.2.6 Derivation process of ctxInc for the syntax element $\text{coeff_abs_level_greater1_flag}$

Inputs to this process are the colour component index cIdx , the current sub-block scan index i , and the current coefficient scan index n within the current sub-block.

Output of this process is the variable ctxInc .

The variable ctxSet specifies the current context set and for its derivation the following apply:

— If this process is invoked for the first time for the current sub-block scan index i , the following apply:

— The variable ctxSet is initialized as follows:

— If the current sub-block scan index i is equal to 0 or cIdx is greater than 0, the following applies:

$$\text{ctxSet} = 0 \tag{9-56}$$

— Otherwise (i is greater than 0 and cIdx is equal to 0), the following applies:

$$\text{ctxSet} = 2 \tag{9-57}$$

— The variable lastGreater1Ctx is derived as follows:

— If the current sub-block with scan index i is the first one to be processed in this subclause for the current transform block, the variable lastGreater1Ctx is set equal to 1.

— Otherwise, the following apply:

— The variable lastGreater1Ctx is set equal to the value of greater1Ctx that has been derived during the last invocation of the process specified in this subclause for a previous sub-block.

— When lastGreater1Ctx is greater than 0, the variable lastGreater1Flag is set equal to the value of the syntax element $\text{coeff_abs_level_greater1_flag}$ that has been used

during the last invocation of the process specified in this subclause for a previous sub-block and `lastGreater1Ctx` is modified as follows:

- If `lastGreater1Flag` is equal to 1, `lastGreater1Ctx` is set equal to 0.
- Otherwise (`lastGreater1Flag` is equal to 0), `lastGreater1Ctx` is incremented by 1.
- When `lastGreater1Ctx` is equal to 0, `ctxSet` is incremented by one as follows:

$$\text{ctxSet} = \text{ctxSet} + 1 \quad (9-58)$$

- The variable `greater1Ctx` is set equal to 1.
- Otherwise (this process is not invoked for the first time for the current sub-block scan index `i`), the following apply:
 - The variable `ctxSet` is set equal to the variable `ctxSet` that has been derived during the last invocation of the process specified in this subclause.
 - The variable `greater1Ctx` is set equal to the variable `greater1Ctx` that has been derived during the last invocation of the process specified in this subclause.
 - When `greater1Ctx` is greater than 0, the variable `lastGreater1Flag` is set equal to the syntax element `coeff_abs_level_greater1_flag` that has been used during the last invocation of the process specified in this subclause and `greater1Ctx` is modified as follows:
 - If `lastGreater1Flag` is equal to 1, `greater1Ctx` is set equal to 0.
 - Otherwise (`lastGreater1Flag` is equal to 0), `greater1Ctx` is incremented by 1.

The context index increment `ctxInc` is derived using the current context set `ctxSet` and the current context `greater1Ctx` as follows:

$$\text{ctxInc} = (\text{ctxSet} * 4) + \text{Min}(3, \text{greater1Ctx}) \quad (9-59)$$

When `cIdx` is greater than 0, `ctxInc` is modified as follows:

$$\text{ctxInc} = \text{ctxInc} + 16 \quad (9-60)$$

9.3.4.2.7 Derivation process of `ctxInc` for the syntax element `coeff_abs_level_greater2_flag`

Inputs to this process are the colour component index `cIdx`, the current sub-block scan index `i`, and the current coefficient scan index `n` within the current sub-block.

Output of this process is the variable `ctxInc`.

The variable `ctxSet` specifies the current context set and is set equal to the value of the variable `ctxSet` that has been derived in 9.3.4.2.6 for the same subset `i`.

The context index increment `ctxInc` is set equal to the variable `ctxSet` as follows:

$$\text{ctxInc} = \text{ctxSet} \quad (9-61)$$

When `cIdx` is greater than 0, `ctxInc` is modified as follows:

$$\text{ctxInc} = \text{ctxInc} + 4 \quad (9-62)$$

9.3.4.2.8 Derivation process of `ctxInc` for the syntax element `palette_run_prefix`

Inputs to this process are the bin index `binIdx` and the syntax elements `copy_above_palette_indices_flag` and `palette_index_idc`.

ISO/IEC 23008-2:2017(E)

Output of this process is the variable `ctxInc`.

The variable `ctxInc` is derived as follows:

- If `copy_above_palette_indices_flag` is equal to 0 and `binIdx` is equal to 0, `ctxInc` is derived as follows:

$$\text{ctxInc} = (\text{palette_index_idc} < 1) ? 0 : ((\text{palette_index_idc} < 3) ? 1 : 2) \tag{9-63}$$
- Otherwise, `ctxInc` is provided by Table 9-51.

Table 9-51 — Specification of `ctxIdxMap[copy_above_palette_indices_flag][binIdx]`

<code>binIdx</code>	0	1	2	3	4	>4
<code>copy_above_palette_indices_flag == 1</code>	5	6	6	7	7	bypass
<code>copy_above_palette_indices_flag == 0</code>	0, 1, 2	3	3	4	4	bypass

9.3.4.3 Arithmetic decoding process

9.3.4.3.1 General

Inputs to this process are `ctxTable`, `ctxIdx`, and `bypassFlag`, as derived in 9.3.4.2, and the state variables `ivlCurrRange` and `ivlOffset` of the arithmetic decoding engine.

Output of this process is the value of the bin.

Figure 9-5 illustrates the whole arithmetic decoding process for a single bin. For decoding the value of a bin, the context index table `ctxTable` and the `ctxIdx` are passed to the arithmetic decoding process `DecodeBin(ctxTable, ctxIdx)`, which is specified as follows:

- If `bypassFlag` is equal to 1, `DecodeBypass()` as specified in 9.3.4.3.4 is invoked.
- Otherwise, if `bypassFlag` is equal to 0, `ctxTable` is equal to 0, and `ctxIdx` is equal to 0, `DecodeTerminate()` as specified in 9.3.4.3.5 is invoked.
- Otherwise (`bypassFlag` is equal to 0 and `ctxTable` is not equal to 0), `DecodeDecision()` as specified in 9.3.4.3.2 is invoked.

STANDARDSISO.COM : Click to view the full PDF of ISO/IEC 23008-2:2017

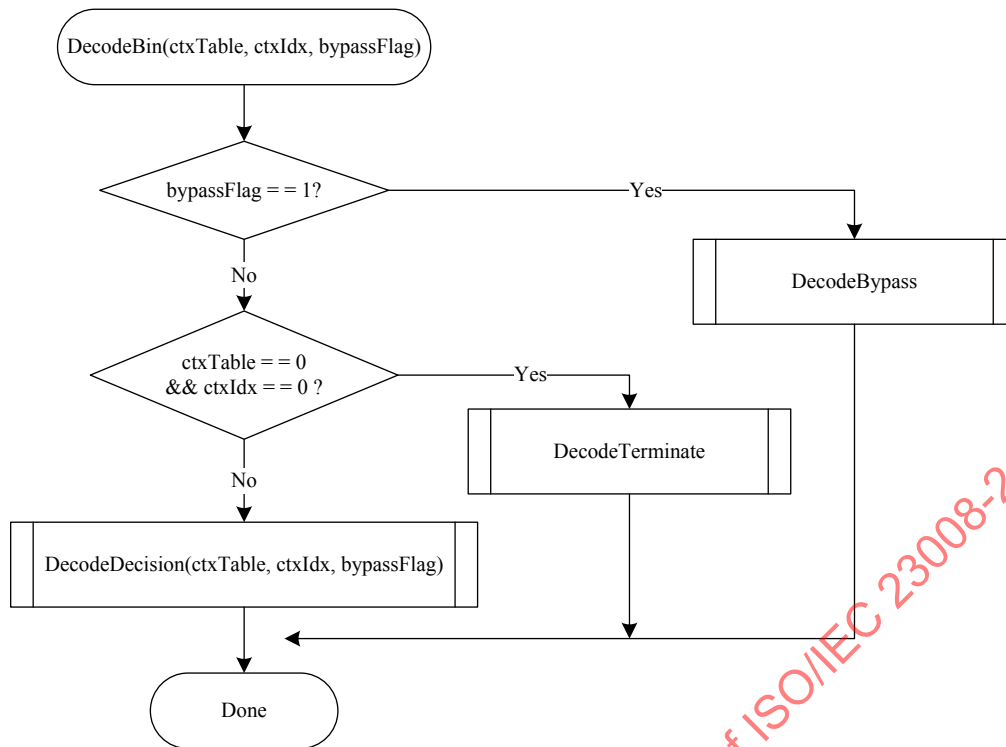

Figure 9-5 — Overview of the arithmetic decoding process for a single bin (informative)

NOTE Arithmetic coding is based on the principle of recursive interval subdivision. Given a probability estimation $p(0)$ and $p(1) = 1 - p(0)$ of a binary decision $(0, 1)$, an initially given code sub-interval with the range $ivlCurrRange$ will be subdivided into two sub-intervals having range $p(0) * ivlCurrRange$ and $ivlCurrRange - p(0) * ivlCurrRange$, respectively. Depending on the decision, which has been observed, the corresponding sub-interval will be chosen as the new code interval, and a binary code string pointing into that interval will represent the sequence of observed binary decisions. It is useful to distinguish between the most probable symbol (MPS) and the least probable symbol (LPS), so that binary decisions have to be identified as either MPS or LPS, rather than 0 or 1. Given this terminology, each context is specified by the probability p_{LPS} of the LPS and the value of MPS ($valMps$), which is either 0 or 1. The arithmetic core engine in this document has three distinct properties.

- The probability estimation is performed by means of a finite-state machine with a table-based transition process between 64 different representative probability states $\{p_{LPS}(pStateIdx) \mid 0 \leq pStateIdx < 64\}$ for the LPS probability p_{LPS} . The numbering of the states is arranged in such a way that the probability state with index $pStateIdx = 0$ corresponds to an LPS probability value of 0.5, with decreasing LPS probability towards higher state indices.
- The range $ivlCurrRange$ representing the state of the coding engine is quantized to a small set $\{Q_1, \dots, Q_4\}$ of pre-set quantization values prior to the calculation of the new interval range. Storing a table containing all 64×4 pre-computed product values of $Q_i * p_{LPS}(pStateIdx)$ allows a multiplication-free approximation of the product $ivlCurrRange * p_{LPS}(pStateIdx)$.
- For syntax elements or parts thereof for which an approximately uniform probability distribution is assumed to be given, a separate simplified encoding and decoding bypass process is used.

9.3.4.3.2 Arithmetic decoding process for a binary decision

9.3.4.3.2.1 General

Inputs to this process are the variables $ctxTable$, $ctxIdx$, $ivlCurrRange$, and $ivlOffset$.

Outputs of this process are the decoded value $binVal$, and the updated variables $ivlCurrRange$ and $ivlOffset$.

Figure 9-6 shows the flowchart for decoding a single decision (DecodeDecision):

1. The value of the variable `ivlLpsRange` is derived as follows:

- Given the current value of `ivlCurrRange`, the variable `qRangeIdx` is derived as follows:

$$qRangeIdx = (ivlCurrRange \gg 6) \& 3 \tag{9-64}$$

- Given `qRangeIdx` and `pStateIdx` associated with `ctxTable` and `ctxIdx`, the value of the variable `rangeTabLps` as specified in Table 9-52 is assigned to `ivlLpsRange`:

$$ivlLpsRange = rangeTabLps[pStateIdx][qRangeIdx] \tag{9-65}$$

2. The variable `ivlCurrRange` is set equal to `ivlCurrRange - ivlLpsRange` and the following apply:

- If `ivlOffset` is greater than or equal to `ivlCurrRange`, the variable `binVal` is set equal to `1 - valMps`, `ivlOffset` is decremented by `ivlCurrRange`, and `ivlCurrRange` is set equal to `ivlLpsRange`.
- Otherwise, the variable `binVal` is set equal to `valMps`.

Given the value of `binVal`, the state transition is performed as specified in 9.3.4.3.2.2. Depending on the current value of `ivlCurrRange`, renormalization is performed as specified in 9.3.4.3.3.

9.3.4.3.2.2 State transition process

Inputs to this process are the current `pStateIdx`, the decoded value `binVal` and `valMps` values of the context variable associated with `ctxTable` and `ctxIdx`.

Outputs of this process are the updated `pStateIdx` and `valMps` of the context variable associated with `ctxIdx`.

Depending on the decoded value `binVal`, the update of the two variables `pStateIdx` and `valMps` associated with `ctxIdx` is derived as follows:

```

if( binVal == valMps )
    pStateIdx = transIdxMps( pStateIdx )
else {
    if( pStateIdx == 0 )
        valMps = 1 - valMps
    pStateIdx = transIdxLps( pStateIdx )
}
    
```

(9-66)

Table 9-53 specifies the transition rules `transIdxMps()` and `transIdxLps()` after decoding the value of `valMps` and `1 - valMps`, respectively.

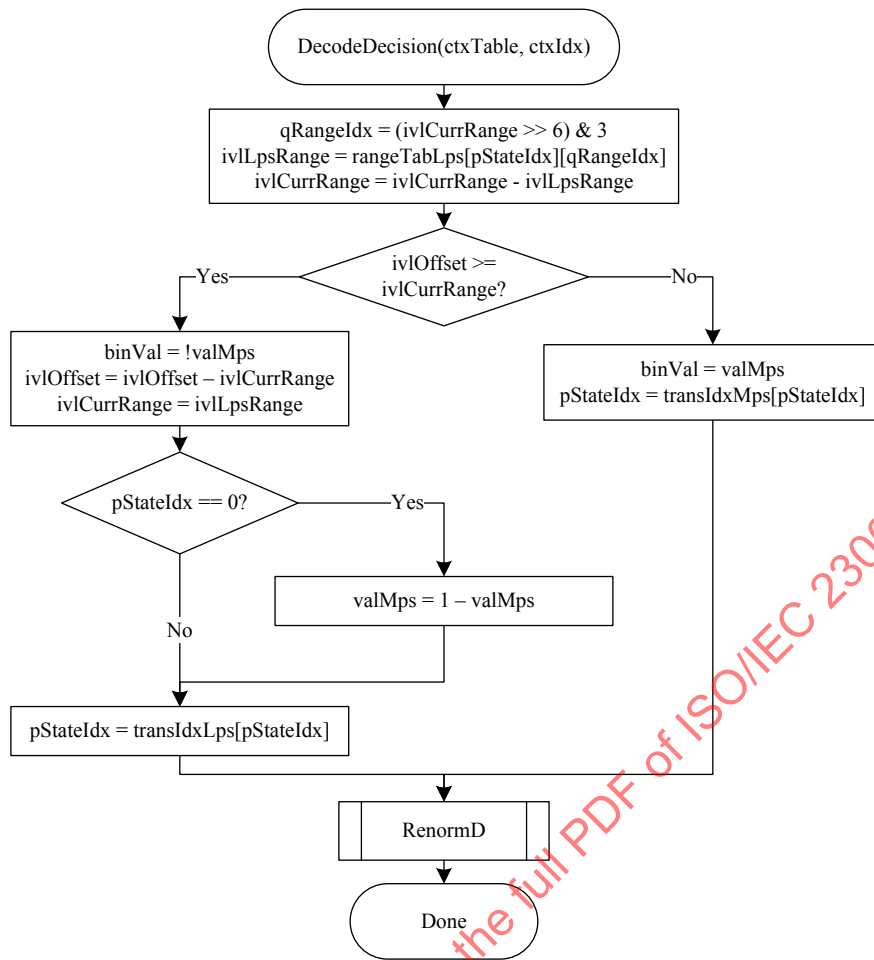

Figure 9-6 — Flowchart for decoding a decision

Table 9-52 — Specification of rangeTabLps depending on the values of pStateIdx and qRangeIdx

pStateIdx	qRangeIdx				pStateIdx	qRangeIdx			
	0	1	2	3		0	1	2	3
0	128	176	208	240	32	27	33	39	45
1	128	167	197	227	33	26	31	37	43
2	128	158	187	216	34	24	30	35	41
3	123	150	178	205	35	23	28	33	39
4	116	142	169	195	36	22	27	32	37
5	111	135	160	185	37	21	26	30	35
6	105	128	152	175	38	20	24	29	33
7	100	122	144	166	39	19	23	27	31
8	95	116	137	158	40	18	22	26	30
9	90	110	130	150	41	17	21	25	28
10	85	104	123	142	42	16	20	23	27
11	81	99	117	135	43	15	19	22	25
12	77	94	111	128	44	14	18	21	24
13	73	89	105	122	45	14	17	20	23

14	69	85	100	116	46	13	16	19	22
15	66	80	95	110	47	12	15	18	21
16	62	76	90	104	48	12	14	17	20
17	59	72	86	99	49	11	14	16	19
18	56	69	81	94	50	11	13	15	18
19	53	65	77	89	51	10	12	15	17
20	51	62	73	85	52	10	12	14	16
21	48	59	69	80	53	9	11	13	15
22	46	56	66	76	54	9	11	12	14
23	43	53	63	72	55	8	10	12	14
24	41	50	59	69	56	8	9	11	13
25	39	48	56	65	57	7	9	11	12
26	37	45	54	62	58	7	9	10	12
27	35	43	51	59	59	7	8	10	11
28	33	41	48	56	60	6	8	9	11
29	32	39	46	53	61	6	7	9	10
30	30	37	43	50	62	6	7	8	9
31	29	35	41	48	63	2	2	2	2

Table 9-53 — State transition table

pStateIdx	0	1	2	3	4	5	6	7	8	9	10	11	12	13	14	15
transIdxLps	0	0	1	2	2	4	4	5	6	7	8	9	9	11	11	12
transIdxMps	1	2	3	4	5	6	7	8	9	10	11	12	13	14	15	16
pStateIdx	16	17	18	19	20	21	22	23	24	25	26	27	28	29	30	31
transIdxLps	13	13	15	15	16	16	18	18	19	19	21	21	22	22	23	24
transIdxMps	17	18	19	20	21	22	23	24	25	26	27	28	29	30	31	32
pStateIdx	32	33	34	35	36	37	38	39	40	41	42	43	44	45	46	47
transIdxLps	24	25	26	26	27	27	28	29	29	30	30	30	31	32	32	33
transIdxMps	33	34	35	36	37	38	39	40	41	42	43	44	45	46	47	48
pStateIdx	48	49	50	51	52	53	54	55	56	57	58	59	60	61	62	63
transIdxLps	33	33	34	34	35	35	35	36	36	36	37	37	37	38	38	63
transIdxMps	49	50	51	52	53	54	55	56	57	58	59	60	61	62	62	63

9.3.4.3.3 Renormalization process in the arithmetic decoding engine

Inputs to this process are bits from slice segment data and the variables ivlCurrRange and ivlOffset.

Outputs of this process are the updated variables ivlCurrRange and ivlOffset.

A flowchart of the renormalization is shown in Figure 9-7. The current value of ivlCurrRange is first compared to 256 and then the following apply:

- If ivlCurrRange is greater than or equal to 256, no renormalization is needed and the RenormD process is finished.

- Otherwise ($ivlCurrRange$ is less than 256), the renormalization loop is entered. Within this loop, the value of $ivlCurrRange$ is doubled, i.e. left-shifted by 1 and a single bit is shifted into $ivlOffset$ by using `read_bits(1)`.

The bitstream shall not contain data that result in a value of $ivlOffset$ being greater than or equal to $ivlCurrRange$ upon completion of this process.

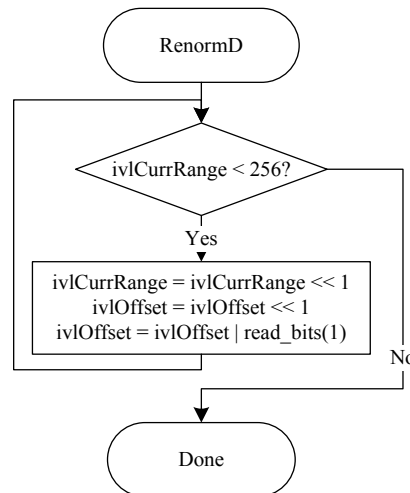

Figure 9-7 — Flowchart of renormalization

9.3.4.3.4 Bypass decoding process for binary decisions

Inputs to this process are bits from slice segment data and the variables $ivlCurrRange$ and $ivlOffset$.

Outputs of this process are the updated variable $ivlOffset$ and the decoded value $binVal$.

The bypass decoding process is invoked when `bypassFlag` is equal to 1. Figure 9-8 shows a flowchart of the corresponding process.

First, the value of $ivlOffset$ is doubled, i.e. left-shifted by 1 and a single bit is shifted into $ivlOffset$ by using `read_bits(1)`. Then, the value of $ivlOffset$ is compared to the value of $ivlCurrRange$ and then the following apply:

- If $ivlOffset$ is greater than or equal to $ivlCurrRange$, the variable $binVal$ is set equal to 1 and $ivlOffset$ is decremented by $ivlCurrRange$.
- Otherwise ($ivlOffset$ is less than $ivlCurrRange$), the variable $binVal$ is set equal to 0.

The bitstream shall not contain data that result in a value of $ivlOffset$ being greater than or equal to $ivlCurrRange$ upon completion of this process.

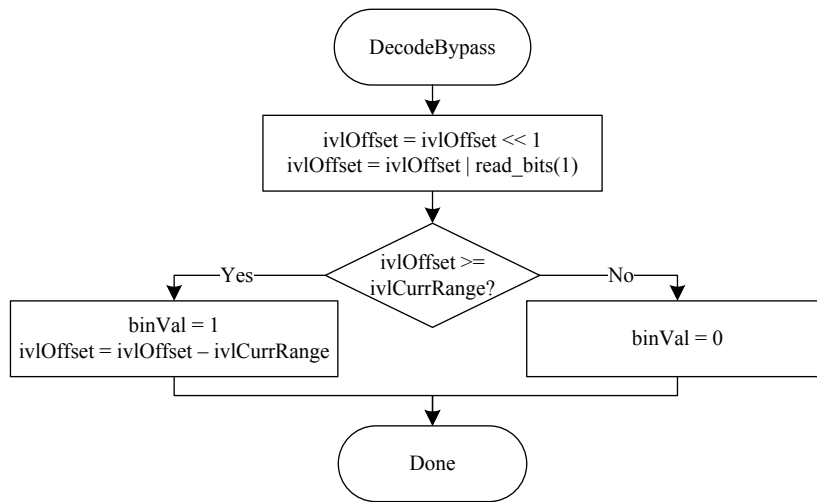

Figure 9-8 — Flowchart of bypass decoding process

9.3.4.3.5 Decoding process for binary decisions before termination

Inputs to this process are bits from slice segment data and the variables *ivlCurrRange* and *ivlOffset*.

Outputs of this process are the updated variables *ivlCurrRange* and *ivlOffset*, and the decoded value *binVal*.

This decoding process applies to decoding of *end_of_slice_segment_flag*, *end_of_subset_one_bit* and *pcm_flag* corresponding to *ctxTable* equal to 0 and *ctxIdx* equal to 0. Figure 9-9 shows the flowchart of the corresponding decoding process, which is specified as follows:

First, the value of *ivlCurrRange* is decremented by 2. Then, the value of *ivlOffset* is compared to the value of *ivlCurrRange* and then the following apply:

- If *ivlOffset* is greater than or equal to *ivlCurrRange*, the variable *binVal* is set equal to 1, no renormalization is carried out, and CABAC decoding is terminated. The last bit inserted in register *ivlOffset* is equal to 1. When decoding *end_of_slice_segment_flag*, this last bit inserted in register *ivlOffset* is interpreted as *rsbsp_stop_one_bit*. When decoding *end_of_subset_one_bit*, this last bit inserted in register *ivlOffset* is interpreted as *alignment_bit_equal_to_one*.
- Otherwise (*ivlOffset* is less than *ivlCurrRange*), the variable *binVal* is set equal to 0 and renormalization is performed as specified in 9.3.4.3.3.

NOTE This procedure may also be implemented using `DecodeDecision(ctxTable, ctxIdx, bypassFlag)` with `ctxTable = 0`, `ctxIdx = 0` and `bypassFlag = 0`. In the case where the decoded value is equal to 1, seven more bits would be read by `DecodeDecision(ctxTable, ctxIdx, bypassFlag)` and a decoding process would have to adjust its bitstream pointer accordingly to properly decode following syntax elements.

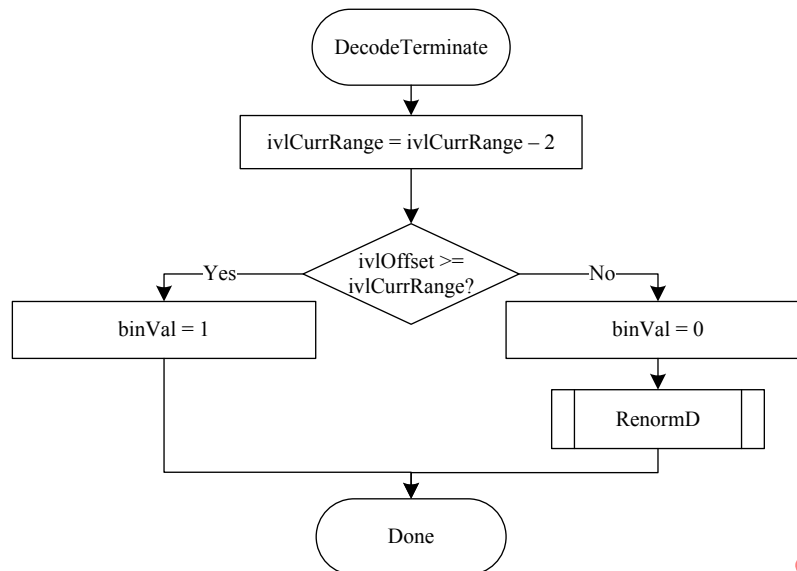

Figure 9-9 — Flowchart of decoding a decision before termination

9.3.4.3.6 Alignment process prior to aligned bypass decoding

Input to this process is the variable `ivlCurrRange`.

Output of this process is the updated variable `ivlCurrRange`.

This process applies prior to the decoding of syntax elements `coeff_abs_level_remaining[]` and `coeff_sign_flag[]`.

`ivlCurrRange` is set equal to 256.

NOTE When `ivlCurrRange` is 256, `ivlOffset` and the bit-stream can be considered as a shift register, and `binVal` as the register's second most significant bit (the most significant bit is always 0 due to the restriction of `ivlOffset` being less than `ivlCurrRange`).

9.3.5 Arithmetic encoding process (informative)

9.3.5.1 General

This subclause does not form an integral part of this document.

Inputs to this process are decisions that are to be encoded and written.

Outputs of this process are bits that are written to the RBSP.

This informative clause describes an arithmetic encoding engine that matches the arithmetic decoding engine described in 9.3.4.3. The encoding engine is essentially symmetric with the decoding engine, i.e. procedures are called in the same order. The following procedures are described in this subclause: `InitEncoder`, `EncodeDecision`, `EncodeBypass`, `EncodeTerminate`, which correspond to `InitDecoder`, `DecodeDecision`, `DecodeBypass`, and `DecodeTerminate`, respectively. The state of the arithmetic encoding engine is represented by a value of the variable `ivlLow` pointing to the lower end of a sub-interval and a value of the variable `ivlCurrRange` specifying the corresponding range of that sub-interval.

9.3.5.2 Initialization process for the arithmetic encoding engine (informative)

This subclause does not form an integral part of this document.

This process is invoked before encoding the first coding block of a slice segment, and after encoding any `pcm_alignment_zero_bit` and all `pcm_sample_luma` and `pcm_sample_chroma` data for a coding unit with `pcm_flag` equal to 1.

Outputs of this process are the values `ivlLow`, `ivlCurrRange`, `firstBitFlag`, `bitsOutstanding`, and `BinCountsInNalUnits` of the arithmetic encoding engine.

In the initialization procedure of the encoder, `ivlLow` is set equal to 0, and `ivlCurrRange` is set equal to 510. Furthermore, `firstBitFlag` is set equal to 1 and the counter `bitsOutstanding` is set equal to 0.

Depending on whether the current slice segment is the first slice segment of a coded picture, the following apply:

- If the current slice segment is the first slice segment of a coded picture, the counter `BinCountsInNalUnits` is set equal to 0.
- Otherwise (the current slice segment is not the first slice segment of a coded picture), the counter `BinCountsInNalUnits` is not modified. The value of `BinCountsInNalUnits` is the result of encoding all the slice segments of a coded picture that precede the current slice segment in decoding order. After initializing for the first slice segment of a coded picture as specified in this subclause, `BinCountsInNalUnits` is incremented as specified in 9.3.5.3, 9.3.5.5, and 9.3.5.6.

NOTE The minimum register precision required for storing the values of the variables `ivlLow` and `ivlCurrRange` after invocation of any of the arithmetic encoding processes specified in 9.3.5.3, 9.3.5.5, and 9.3.5.6 is 10 bits and 9 bits, respectively. The encoding process for a binary decision (`EncodeDecision`) as specified in 9.3.5.3 and the encoding process for a binary decision before termination (`EncodeTerminate`) as specified in 9.3.5.6 require a minimum register precision of 10 bits for the variable `ivlLow` and a minimum register precision of 9 bits for the variable `ivlCurrRange`. The bypass encoding process for binary decisions (`EncodeBypass`) as specified in 9.3.5.5 requires a minimum register precision of 11 bits for the variable `ivlLow` and a minimum register precision of 9 bits for the variable `ivlCurrRange`. The precision required for the counters `bitsOutstanding` and `BinCountsInNalUnits` is expected to be sufficiently large to prevent overflow of the related registers. When `maxBinCountInSlice` denotes the maximum total number of binary decisions to encode in one slice segment and `maxBinCountInPic` denotes the maximum total number of binary decisions to encode a picture, the minimum register precision required for the variables `bitsOutstanding` and `BinCountsInNalUnits` is given by $\text{Ceil}(\text{Log}_2(\text{maxBinCountInSlice} + 1))$ and $\text{Ceil}(\text{Log}_2(\text{maxBinCountInPic} + 1))$, respectively.

9.3.5.3 Encoding process for a binary decision (informative)

This subclause does not form an integral part of this document.

Inputs to this process are the context index `ctxIdx`, the value of `binVal` to be encoded, and the variables `ivlCurrRange`, `ivlLow` and `BinCountsInNalUnits`.

Outputs of this process are the variables `ivlCurrRange`, `ivlLow`, and `BinCountsInNalUnits`.

Figure 9-10 shows the flowchart for encoding a single decision. In a first step, the variable `ivlLpsRange` is derived as follows.

Given the current value of `ivlCurrRange`, `ivlCurrRange` is mapped to the index `qRangeIdx` of a quantized value of `ivlCurrRange` by using Formula (9-64). The value of `qRangeIdx` and the value of `pStateIdx` associated with `ctxIdx` are used to determine the value of the variable `rangeTabLps` as specified in Table 9-52, which is assigned to `ivlLpsRange`. The value of `ivlCurrRange - ivlLpsRange` is assigned to `ivlCurrRange`.

In a second step, the value of `binVal` is compared to `valMps` associated with `ctxIdx`. When `binVal` is different from `valMps`, `ivlCurrRange` is added to `ivlLow` and `ivlCurrRange` is set equal to the value `ivlLpsRange`. Given the encoded decision, the state transition is performed as specified in 9.3.4.3.2.2. Depending on the current value of `ivlCurrRange`, renormalization is performed as specified in 9.3.5.4. Finally, the variable `BinCountsInNalUnits` is incremented by 1.

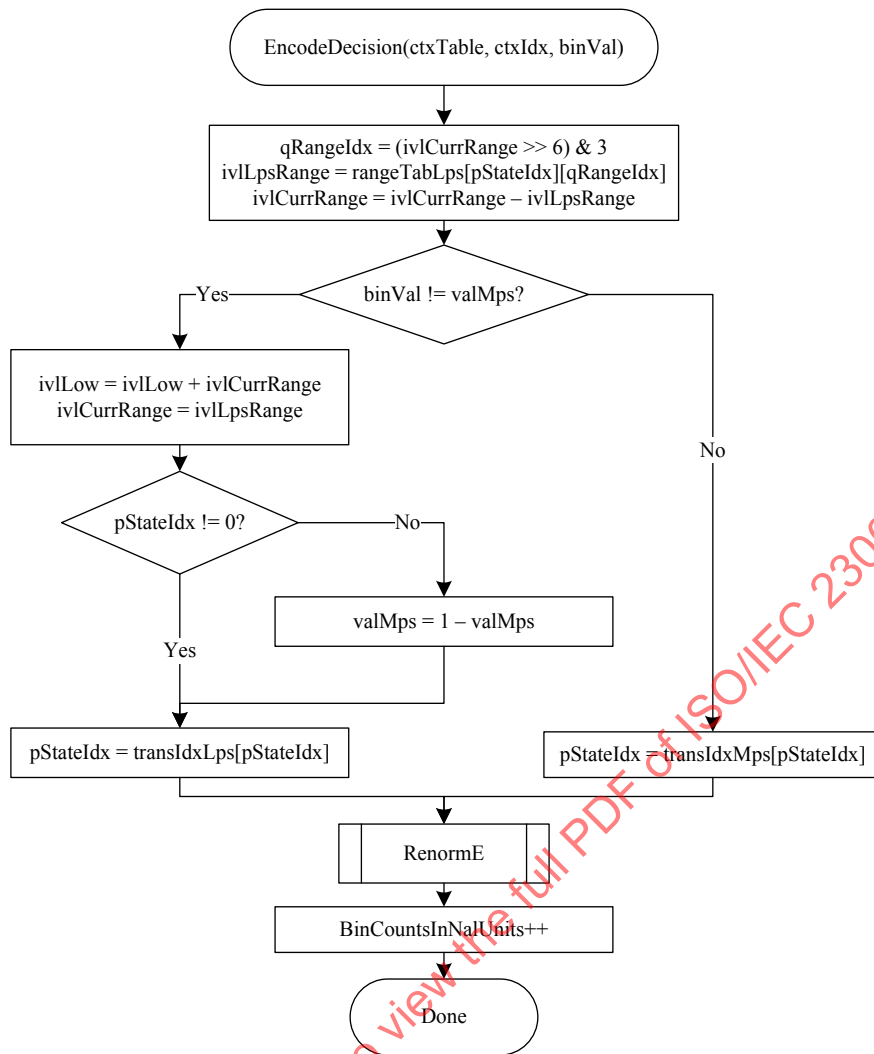

Figure 9-10 — Flowchart for encoding a decision

9.3.5.4 Renormalization process in the arithmetic encoding engine (informative)

This subclause does not form an integral part of this document.

Inputs to this process are the variables ivlCurrRange, ivlLow, firstBitFlag, and bitsOutstanding.

Outputs of this process are zero or more bits written to the RBSP and the updated variables ivlCurrRange, ivlLow, firstBitFlag, and bitsOutstanding.

Renormalization is illustrated in Figure 9-11.

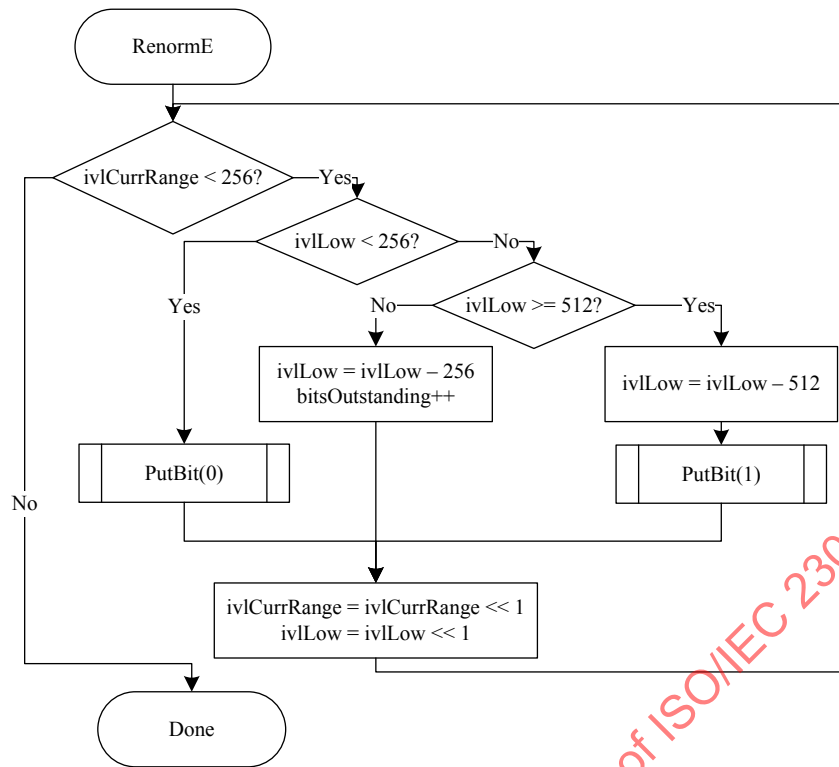

Figure 9-11 — Flowchart of renormalization in the encoder

The PutBit() procedure described in Figure 9-12 provides carry over control. It uses the function WriteBits(B, N) that writes N bits with value B to the bitstream and advances the bitstream pointer by N bit positions. This function assumes the existence of a bitstream pointer with an indication of the position of the next bit to be written to the bitstream by the encoding process.

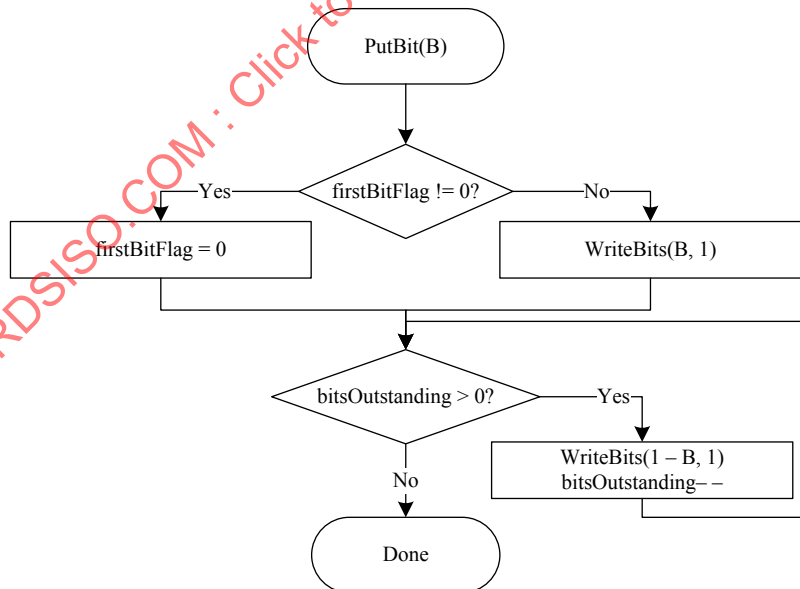

Figure 9-12 — Flowchart of PutBit(B)

9.3.5.5 Bypass encoding process for binary decisions (informative)

This subclause does not form an integral part of this document.

Inputs to this process are the variables `binVal`, `ivlLow`, `ivlCurrRange`, `bitsOutstanding`, and `BinCountsInNalUnits`.

Output of this process is a bit written to the RBSP and the updated variables `ivlLow`, `bitsOutstanding`, and `BinCountsInNalUnits`.

This encoding process applies to all binary decisions with `bypassFlag` equal to 1.

When `cabac_bypass_alignment_enabled_flag` is equal to 1 and `coeff_abs_level_remaining[]` is present for any coefficients in the current sub-block, an alignment process is performed. This alignment process applies prior to the encoding of the syntax elements `coeff_abs_level_remaining[]` and `coeff_sign_flag[]` and sets `ivlCurrRange` to 256.

Renormalization is included in the specification of this bypass encoding process as given in Figure 9-13.

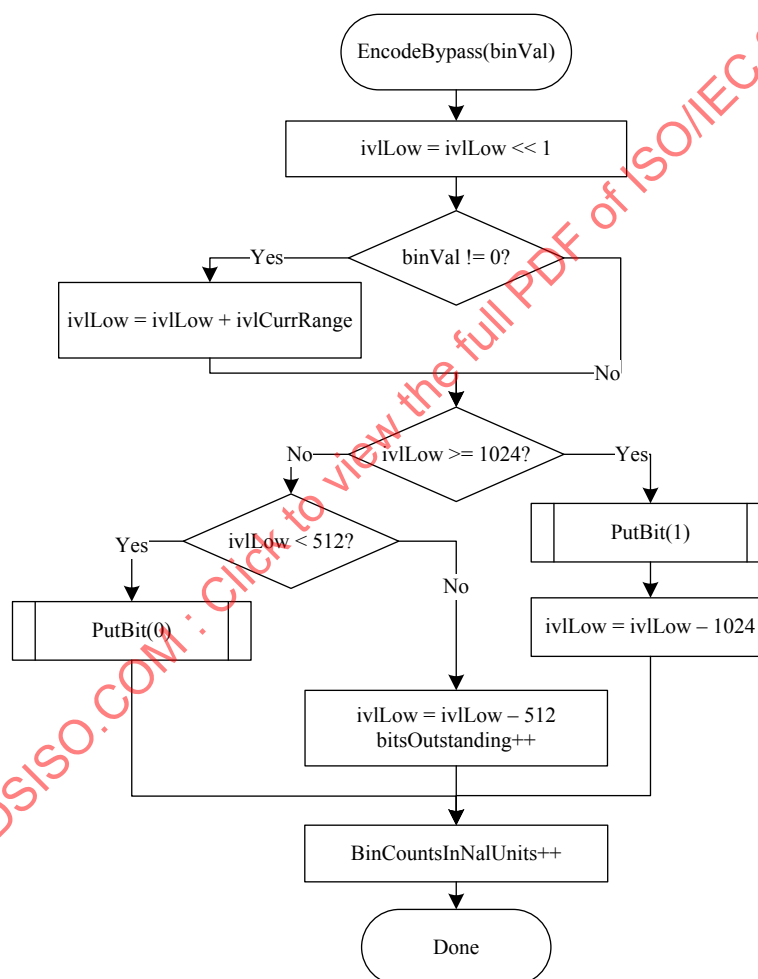

Figure 9-13 — Flowchart of encoding bypass

9.3.5.6 Encoding process for a binary decision before termination (informative)

This subclause does not form an integral part of this document.

Inputs to this process are the variables `binVal`, `ivlCurrRange`, `ivlLow`, `bitsOutstanding`, and `BinCountsInNalUnits`.

ISO/IEC 23008-2:2017(E)

Outputs of this process are zero or more bits written to the RBSP and the updated variables *ivlLow*, *ivlCurrRange*, *bitsOutstanding*, and *BinCountsInNalUnits*.

This encoding routine shown in Figure 9-14 applies to encoding of *end_of_slice_segment_flag*, *end_of_subset_one_bit*, and *pcm_flag*, all associated with *ctxIdx* equal to 0.

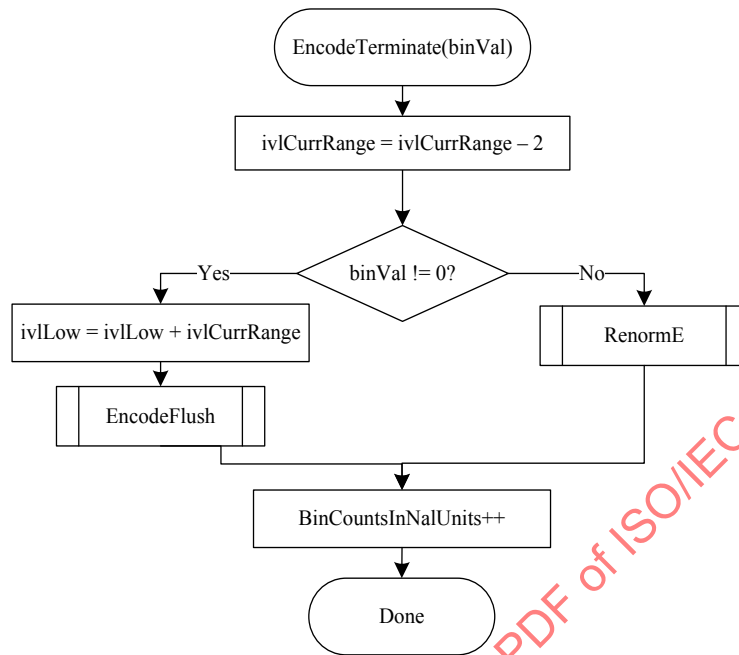

Figure 9-14 — Flowchart of encoding a decision before termination

When the value of *binVal* to encode is equal to 1, CABAC encoding is terminated and the flushing procedure shown in Figure 9-15 is applied. In this flushing procedure, the last bit written by *WriteBits(B, N)* is equal to 1. When encoding *end_of_slice_segment_flag*, this last bit is interpreted as *rbsp_stop_one_bit*. When encoding *end_of_subset_one_bit*, this last bit is interpreted as *alignment_bit_equal_to_one*.

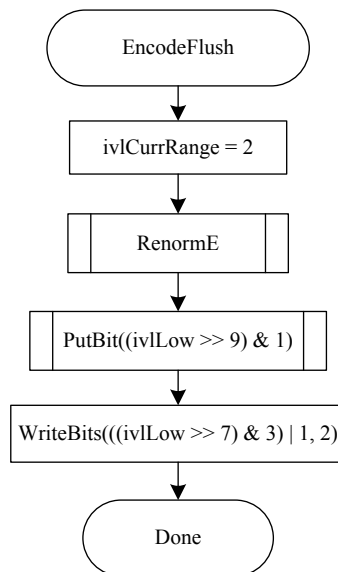

Figure 9-15 — Flowchart of flushing at termination

9.3.5.7 Byte stuffing process (informative)

This subclause does not form an integral part of this document.

This process is invoked after encoding the last coding block of the last slice segment of a picture and after encapsulation.

Inputs to this process are the number of bytes `NumBytesInVclNalUnits` of all VCL NAL units of a picture, the number of minimum CUs `PicSizeInMinCbsY` in the picture, and the number of binary symbols `BinCountsInNalUnits` resulting from encoding the contents of all VCL NAL units of the picture.

NOTE – The value of `BinCountsInNalUnits` is the result of encoding all slice segments of a coded picture. After initializing for the first slice segment of a coded picture as specified in 9.3.5.2, `BinCountsInNalUnits` is incremented as specified in 9.3.5.3, 9.3.5.5, and 9.3.5.6.

Outputs of this process are zero or more bytes appended to the NAL unit.

Let the variable `k` be set equal to

$\text{Ceil}(\text{Ceil}(3 * (32 * \text{BinCountsInNalUnits} - \text{RawMinCuBits} * \text{PicSizeInMinCbsY}) \div 1024) - \text{NumBytesInVclNalUnits}) \div 3$). Depending on the value of `k` the following apply:

- If `k` is less than or equal to 0, no `cabac_zero_word` is appended to the NAL unit.
- Otherwise (`k` is greater than 0), the 3-byte sequence `0x000003` is appended `k` times to the NAL unit after encapsulation, where the first two bytes `0x0000` represent a `cabac_zero_word` and the third byte `0x03` represents an `emulation_prevention_three_byte`.

10 Sub-bitstream extraction process

Inputs to this process are a bitstream, a target highest `TemporalId` value `tIdTarget`, and a target layer identifier list `layerIdListTarget`.

Output of this process is a sub-bitstream.

It is a requirement of bitstream conformance for the input bitstream that any output sub-bitstream that is the output of the process specified in this clause with the bitstream, `tIdTarget` equal to any value in the range of 0 to 6, inclusive, and `layerIdListTarget` either equal to the layer identifier list associated with a layer set specified in the active VPS or consisting of all the `nuh_layer_id` values of the VCL NAL units present in the input bitstream as inputs, and that satisfies both of the following conditions shall be a conforming bitstream:

- The output sub-bitstream contains at least one VCL NAL unit with `nuh_layer_id` equal to each of the `nuh_layer_id` values in `layerIdListTarget`.
- The output sub-bitstream contains at least one VCL NAL unit with `TemporalId` equal to `tIdTarget`.

NOTE 1 A bitstream conforming to a profile specified in Annex A contains one or more coded slice segment NAL units with `nuh_layer_id` equal to 0.

NOTE 2 A conforming bitstream contains one or more coded slice segment NAL units with `TemporalId` equal to 0.

The output sub-bitstream is derived as follows:

- When one or more of the following two conditions are true, remove all SEI NAL units that have `nuh_layer_id` equal to 0 and that contain a non-nested buffering period SEI message, a non-nested picture timing SEI message, or a non-nested decoding unit information SEI message:
 - `layerIdListTarget` does not include all the values of `nuh_layer_id` in all NAL units in the bitstream.

ISO/IEC 23008-2:2017(E)

- `tIdTarget` is less than the greatest `TemporalId` in all NAL units in the bitstream.

NOTE 3 A “smart” bitstream extractor can include appropriate non-nested buffering picture SEI messages, non-nested picture timing SEI messages, and non-nested decoding unit information SEI messages in the extracted sub-bitstream, provided that the SEI messages applicable to the sub-bitstream were present as nested SEI messages in the original bitstream.

- Remove all NAL units with `TemporalId` greater than `tIdTarget` or `nuh_layer_id` not among the values included in `layerIdListTarget`.

STANDARDSISO.COM : Click to view the full PDF of ISO/IEC 23008-2:2017

Annex A (normative)

Profiles, tiers and levels

A.1 Overview of profiles, tiers and levels

Profiles, tiers and levels specify restrictions on bitstreams and hence limits on the capabilities needed to decode the bitstreams. Profiles, tiers and levels may also be used to indicate interoperability points between individual decoder implementations.

NOTE 1 This document does not include individually selectable “options” at the decoder, as this would increase interoperability difficulties.

Each profile specifies a subset of algorithmic features and limits that shall be supported by all decoders conforming to that profile.

NOTE 2 Encoders are not required to make use of any particular subset of features supported in a profile.

Each level of a tier specifies a set of limits on the values that may be taken by the syntax elements of this document. The same set of tier and level definitions is used with all profiles, but individual implementations may support a different tier and within a tier a different level for each supported profile. For any given profile, a level of a tier generally corresponds to a particular decoder processing load and memory capability.

The profiles that are specified in A.3 are also referred to as the profiles specified in this annex.

A.2 Requirements on video decoder capability

Capabilities of video decoders conforming to this document are specified in terms of the ability to decode video streams conforming to the constraints of profiles, tiers and levels specified in this annex and other annexes. When expressing the capabilities of a decoder for a specified profile, the tier and level supported for that profile should also be expressed.

Specific values are specified in this annex and other annexes for the syntax elements `general_profile_idc`, `general_tier_flag`, `general_level_idc`, `sub_layer_profile_idc[i]`, `sub_layer_tier_flag[i]`, and `sub_layer_level_idc[i]`. All other values of `general_profile_idc`, `general_level_idc`, `sub_layer_profile_idc[i]`, and `sub_layer_level_idc[i]` are reserved for future use by ITU-T | ISO/IEC.

NOTE Decoders are not expected to infer that a reserved value of `general_profile_idc` or `sub_layer_profile_idc[i]` between the values specified in this document indicates intermediate capabilities between the specified profiles, as there are no restrictions on the method to be chosen by ITU-T | ISO/IEC for the use of such future reserved values. However, decoders are expected to infer that a reserved value of `general_level_idc` or `sub_layer_level_idc[i]` associated with a particular value of `general_tier_flag` or `sub_layer_tier_flag[i]`, respectively, between the values specified in this document indicates intermediate capabilities between the specified levels of the tier.

A.3 Profiles

A.3.1 General

All constraints for PPSs that are specified are constraints for PPSs that are activated when the bitstream is decoded. All constraints for SPSs that are specified are constraints for SPSs that are activated when the bitstream is decoded.

The variable `RawCtuBits` is derived as follows:

$$\text{RawCtuBits} = \text{CtbSizeY} * \text{CtbSizeY} * \text{BitDepth}_Y + 2 * (\text{CtbWidthC} * \text{CtbHeightC}) * \text{BitDepth}_C \quad (\text{A-1})$$

A.3.2 Main profile

Bitstreams conforming to the Main profile shall obey the following constraints:

- Active VPSs shall have `vps_base_layer_internal_flag` and `vps_base_layer_available_flag` both equal to 1 only.
- Active SPSs for the base layer shall have `chroma_format_idc` equal to 1 only.
- Active SPSs for the base layer shall have `bit_depth_luma_minus8` equal to 0 only.
- Active SPSs for the base layer shall have `bit_depth_chroma_minus8` equal to 0 only.
- Active SPSs for the base layer shall have `transform_skip_rotation_enabled_flag`, `transform_skip_context_enabled_flag`, `implicit_rdpcm_enabled_flag`, `explicit_rdpcm_enabled_flag`, `extended_precision_processing_flag`, `intra_smoothing_disabled_flag`, `high_precision_offsets_enabled_flag`, `persistent_rice_adaptation_enabled_flag`, `cabac_bypass_alignment_enabled_flag`, `sps_curr_pic_ref_enabled_flag`, `palette_mode_enabled_flag`, `motion_vector_resolution_control_idc`, and `intra_boundary_filtering_disabled_flag`, when present, equal to 0 only.
- `CtbLog2SizeY` derived according to active SPSs for the base layer shall be in the range of 4 to 6, inclusive.
- Active PPSs for the base layer shall have `log2_max_transform_skip_block_size_minus2`, `chroma_qp_offset_list_enabled_flag`, and `residual_adaptive_colour_transform_enabled_flag`, when present, equal to 0 only.
- When an active PPS for the base layer has `tiles_enabled_flag` equal to 1, it shall have `entropy_coding_sync_enabled_flag` equal to 0.
- When an active PPS for the base layer has `tiles_enabled_flag` equal to 1, `ColumnWidthInLumaSamples[i]` shall be greater than or equal to 256 for all values of `i` in the range of 0 to `num_tile_columns_minus1`, inclusive, and `RowHeightInLumaSamples[j]` shall be greater than or equal to 64 for all values of `j` in the range of 0 to `num_tile_rows_minus1`, inclusive.
- The number of times `read_bits(1)` is called in 9.3.4.3.3 and 9.3.4.3.4 when parsing `coding_tree_unit()` data for any coding tree unit shall be less than or equal to $5 * \text{RawCtuBits} / 3$.
- `general_level_idc` and `sub_layer_level_idc[i]` for all values of `i` in active SPSs for the base layer shall not be equal to 255 (which indicates level 8.5).
- The level constraints specified for the Main profile in A.4 shall be fulfilled.

Conformance of a bitstream to the Main profile is indicated by `general_profile_idc` being equal to 1 or `general_profile_compatibility_flag[1]` being equal to 1. Conformance of a sub-layer representation with `TemporalId` equal to `i` to the Main profile is indicated by `sub_layer_profile_idc[i]` being equal to 1 or `sub_layer_profile_compatibility_flag[i][1]` being equal to 1.

NOTE When `general_profile_compatibility_flag[1]` is equal to 1, `general_profile_compatibility_flag[2]` is also expected to be equal to 1. When `sub_layer_profile_compatibility_flag[i][1]` is equal to 1 for a value of `i`, `sub_layer_profile_compatibility_flag[i][2]` is also expected to be equal to 1.

Decoders conforming to the Main profile at a specific level (identified by a specific value of `general_level_idc`) of a specific tier (identified by a specific value of `general_tier_flag`) shall be capable of decoding all bitstreams and sub-layer representations for which all of the following conditions apply:

- The bitstream or sub-layer representation is indicated to conform to the Main profile or the Main Still Picture profile.
- The bitstream or sub-layer representation is indicated to conform to a level that is not level 8.5 and is lower than or equal to the specified level.
- The bitstream or sub-layer representation is indicated to conform to a tier that is lower than or equal to the specified tier.

A.3.3 Main 10 profile

Bitstreams conforming to the Main 10 profile shall obey the following constraints:

- Active VPSs shall have `vps_base_layer_internal_flag` and `vps_base_layer_available_flag` both equal to 1 only.
- Active SPSs for the base layer shall have `chroma_format_idc` equal to 1 only.
- Active SPSs for the base layer shall have `bit_depth_luma_minus8` in the range of 0 to 2, inclusive.
- Active SPSs for the base layer shall have `bit_depth_chroma_minus8` in the range of 0 to 2, inclusive.
- Active SPSs for the base layer shall have `transform_skip_rotation_enabled_flag`, `transform_skip_context_enabled_flag`, `implicit_rdp_pcm_enabled_flag`, `explicit_rdp_pcm_enabled_flag`, `extended_precision_processing_flag`, `intra_smoothing_disabled_flag`, `high_precision_offsets_enabled_flag`, `persistent_rice_adaptation_enabled_flag`, `cabac_bypass_alignment_enabled_flag`, `sps_curr_pic_ref_enabled_flag`, `palette_mode_enabled_flag`, `motion_vector_resolution_control_idc`, and `intra_boundary_filtering_disabled_flag`, when present, equal to 0 only.
- `CtbLog2SizeY` derived according to active SPSs for the base layer shall be in the range of 4 to 6, inclusive.
- Active PPSs for the base layer shall have `log2_max_transform_skip_block_size_minus2`, `chroma_qp_offset_list_enabled_flag`, and `residual_adaptive_colour_transform_enabled_flag`, when present, equal to 0 only.
- When an active PPS for the base layer has `tiles_enabled_flag` equal to 1, it shall have `entropy_coding_sync_enabled_flag` equal to 0.
- When an active PPS for the base layer has `tiles_enabled_flag` equal to 1, `ColumnWidthInLumaSamples[i]` shall be greater than or equal to 256 for all values of `i` in the range of 0 to `num_tile_columns_minus1`, inclusive, and `RowHeightInLumaSamples[j]` shall be greater than or equal to 64 for all values of `j` in the range of 0 to `num_tile_rows_minus1`, inclusive.
- The number of times `read_bits(1)` is called in 9.3.4.3.3 and 9.3.4.3.4 when parsing `coding_tree_unit()` data for any coding tree unit shall be less than or equal to $5 * \text{RawCtuBits} / 3$.
- `general_level_idc` and `sub_layer_level_idc[i]` for all values of `i` in active SPSs for the base layer shall not be equal to 255 (which indicates level 8.5).
- The level constraints specified for the Main 10 profile in A.4 shall be fulfilled.

ISO/IEC 23008-2:2017(E)

Conformance of a bitstream to the Main 10 profile is indicated by `general_profile_idc` being equal to 2 or `general_profile_compatibility_flag[2]` being equal to 1. Conformance of a sub-layer representation with TemporalId equal to `i` to the Main 10 profile is indicated by `sub_layer_profile_idc[i]` being equal to 2 or `sub_layer_profile_compatibility_flag[i][2]` being equal to 1.

Decoders conforming to the Main 10 profile at a specific level (identified by a specific value of `general_level_idc`) shall be capable of decoding all bitstreams and sub-layer representations for which all of the following conditions apply:

- The bitstream or sub-layer representation is indicated to conform to the Main 10 profile, the Main profile, or the Main Still Picture profile.
- The bitstream or sub-layer representation is indicated to conform to a level that is not level 8.5 and is lower than or equal to the specified level.
- The bitstream or sub-layer representation is indicated to conform to a tier that is lower than or equal to the specified tier.

A.3.4 Main Still Picture profile

Bitstreams conforming to the Main Still Picture profile shall obey the following constraints:

- The bitstream shall contain only one picture with `nuh_layer_id` equal to 0.
- Active VPSs shall have `vps_base_layer_internal_flag` and `vps_base_layer_available_flag` both equal to 1 only.
- Active SPSs for the base layer shall have `chroma_format_idc` equal to 1 only.
- Active SPSs for the base layer shall have `bit_depth_luma_minus8` equal to 0 only.
- Active SPSs for the base layer shall have `bit_depth_chroma_minus8` equal to 0 only.
- Active SPSs for the base layer shall have `sps_max_dec_pic_buffering_minus1[sps_max_sub_layers_minus1]` equal to 0 only.
- Active SPSs for the base layer shall have `transform_skip_rotation_enabled_flag`, `transform_skip_context_enabled_flag`, `implicit_rdpkm_enabled_flag`, `explicit_rdpkm_enabled_flag`, `extended_precision_processing_flag`, `intra_smoothing_disabled_flag`, `high_precision_offsets_enabled_flag`, `persistent_rice_adaptation_enabled_flag`, `cabac_bypass_alignment_enabled_flag`, `sps_curr_pic_ref_enabled_flag`, `palette_mode_enabled_flag`, `motion_vector_resolution_control_idc`, and `intra_boundary_filtering_disabled_flag`, when present, equal to 0 only.
- `CtbLog2SizeY` derived according to active SPSs for the base layer shall be in the range of 4 to 6, inclusive.
- Active PPSs for the base layer shall have `log2_max_transform_skip_block_size_minus2`, `chroma_qp_offset_list_enabled_flag`, and `residual_adaptive_colour_transform_enabled_flag`, when present, equal to 0 only.
- When an active PPS for the base layer has `tiles_enabled_flag` equal to 1, it shall have `entropy_coding_sync_enabled_flag` equal to 0.
- When an active PPS for the base layer has `tiles_enabled_flag` equal to 1, `ColumnWidthInLumaSamples[i]` shall be greater than or equal to 256 for all values of `i` in the

range of 0 to `num_tile_columns_minus1`, inclusive, and `RowHeightInLumaSamples[j]` shall be greater than or equal to 64 for all values of `j` in the range of 0 to `num_tile_rows_minus1`, inclusive.

- The number of times `read_bits(1)` is called in 9.3.4.3.3 and 9.3.4.3.4 when parsing `coding_tree_unit()` data for any coding tree unit shall be less than or equal to $5 * \text{RawCtuBits} / 3$.
- The level constraints specified for the Main Still Picture profile in A.4 shall be fulfilled.

Conformance of a bitstream to the Main Still Picture profile is indicated by `general_profile_idc` being equal to 3 or `general_profile_compatibility_flag[3]` being equal to 1.

NOTE When `general_profile_compatibility_flag[3]` is equal to 1, `general_profile_compatibility_flag[1]` and `general_profile_compatibility_flag[2]` are also expected to be equal to 1. When `sub_layer_profile_compatibility_flag[i][3]` is equal to 1 for a value of `i`, `sub_layer_profile_compatibility_flag[i][1]` and `sub_layer_profile_compatibility_flag[i][2]` are also expected to be equal to 1.

Decoders conforming to the Main Still Picture profile at a specific level (identified by a specific value of `general_level_idc`) shall be capable of decoding all bitstreams for which all of the following conditions apply:

- `general_profile_idc` is equal to 3 or `general_profile_compatibility_flag[3]` is equal to 1.
- `general_level_idc` is not equal to 255 and represents a level lower than or equal to the specified level.
- `general_tier_flag` represents a tier lower than or equal to the specified tier.

A.3.5 Format range extensions profiles

The following profiles, collectively referred to as the format range extensions profiles, are specified in this subclause:

- the Monochrome, Monochrome 12 and Monochrome 16 profiles;
- the Main 12 profile;
- the Main 4:2:2 10 and Main 4:2:2 12 profiles;
- the Main 4:4:4, Main 4:4:4 10, and Main 4:4:4 12 profiles;
- the Main Intra, Main 10 Intra, Main 12 Intra, Main 4:2:2 10 Intra, Main 4:2:2 12 Intra, Main 4:4:4 Intra, Main 4:4:4 10 Intra, Main 4:4:4 12 Intra, and Main 4:4:4 16 Intra profiles;
- the Main 4:4:4 Still Picture and Main 4:4:4 16 Still Picture profiles.

Bitstreams conforming to the format range extensions profiles shall obey the following constraints:

- The constraints specified in Table A.1 shall apply, in which entries marked with "-" indicate that the table entry does not impose a profile-specific constraint on the corresponding syntax element.

NOTE For some syntax elements with table entries marked with "-", a constraint may be imposed indirectly, e.g. by semantics constraints that are imposed elsewhere in this document when other specified constraints are fulfilled.

- Active VPSs shall have `vps_base_layer_internal_flag` and `vps_base_layer_available_flag` both equal to 1 only.

ISO/IEC 23008-2:2017(E)

- Active SPSs for the base layer shall have `separate_colour_plane_flag`, `cabac_bypass_alignment_enabled_flag`, `sps_curr_pic_ref_enabled_flag`, `palette_mode_enabled_flag`, `motion_vector_resolution_control_idc`, and `intra_boundary_filtering_disabled_flag`, when present, equal to 0 only.
- `CtbLog2SizeY` derived according to active SPSs for the base layer shall be in the range of 4 to 6, inclusive.
- Active PPSs for the base layer shall have `residual_adaptive_colour_transform_enabled_flag`, when present, equal to 0 only.
- When an active PPS for the base layer has `tiles_enabled_flag` equal to 1, it shall have `entropy_coding_sync_enabled_flag` equal to 0.
- When an active PPS for the base layer has `tiles_enabled_flag` equal to 1, `ColumnWidthInLumaSamples[i]` shall be greater than or equal to 256 for all values of `i` in the range of 0 to `num_tile_columns_minus1`, inclusive, and `RowHeightInLumaSamples[j]` shall be greater than or equal to 64 for all values of `j` in the range of 0 to `num_tile_rows_minus1`, inclusive.
- In bitstreams conforming to the Main Intra, Main 10 Intra, Main 12 Intra, Main 4:2:2 10 Intra, Main 4:2:2 12 Intra, Main 4:4:4 Intra, Main 4:4:4 10 Intra, Main 4:4:4 12 Intra, or Main 4:4:4 16 Intra profiles, all pictures with `nuh_layer_id` equal to 0 shall be IRAP pictures and the output order indicated in the bitstream among these pictures shall be the same as the decoding order.
- The number of times `read_bits(1)` is called in 9.3.4.3.3 and 9.3.4.3.4 when parsing `coding_tree_unit()` data for any coding tree unit shall be less than or equal to $5 * \text{RawCtuBits} / 3$.
- In bitstreams conforming to the Main 4:4:4 Still Picture and Main 4:4:4 16 Still Picture profiles, the following constraints shall apply:
 - The bitstream shall contain only one picture with `nuh_layer_id` equal to 0.
 - Active SPSs for the base layer shall have `sps_max_dec_pic_buffering_minus1[sps_max_sub_layers_minus1]` equal to 0 only.
- In bitstreams conforming to the Monochrome, Monochrome 12, Monochrome 16, Main 12, Main 4:2:2 10, Main 4:2:2 12, Main 4:4:4, Main 4:4:4 10, Main 4:4:4 12, Main Intra, Main 10 Intra, Main 12 Intra, Main 4:2:2 10 Intra, Main 4:2:2 12 Intra, Main 4:4:4 Intra, Main 4:4:4 10 Intra, Main 4:4:4 12 Intra, or Main 4:4:4 16 Intra profiles, `general_level_idc` and `sub_layer_level_idc[i]` for all values of `i` in active SPSs for the base layer shall not be equal to 255 (which indicates level 8.5).
- The level constraints specified for the Monochrome, Monochrome 12, Monochrome 16, Main 12, Main 4:2:2 10, Main 4:2:2 12, Main 4:4:4 10, Main 4:4:4 12, Main Intra, Main 10 Intra, Main 12 Intra, Main 4:2:2 10 Intra, Main 4:2:2 12 Intra, Main 4:4:4 10 Intra, Main 4:4:4 12 Intra, or Main 4:4:4 16 Intra profiles in A.4, as applicable, shall be fulfilled.

Table A.1 — Allowed values for syntax elements in the format range extensions profiles

Profile for which constraint is specified	chroma_format_idc	bit_depth_luma_minus8 and bit_depth_chroma_minus8	transform_skip_rotation_enabled_flag, transform_skip_context_enabled_flag, implicit_rdpccm_enabled_flag, explicit_rdpccm_enabled_flag, intra_smoothing_disabled_flag, persistent_rice_adaptation_enabled_flag, and log2_max_transform_skip_block_size_minus2	extended_precision_processing_flag	chroma_qp_offset_list_enabled_flag
Monochrome	0	0	0	0	0
Monochrome 12	0	0..4	0	0	0
Monochrome 16	0	-	-	-	0
Main 12	0 or 1	0..4	0	0	0
Main 4:2:2 10	0..2	0..2	0	0	-
Main 4:2:2 12	0..2	0..4	0	0	-
Main 4:4:4	-	0	-	0	-
Main 4:4:4 10	-	0..2	-	0	-
Main 4:4:4 12	-	0..4	-	0	-
Main Intra	0 or 1	0	0	0	0
Main 10 Intra	0 or 1	0..2	0	0	0
Main 12 Intra	0 or 1	0..4	0	0	0
Main 4:2:2 10 Intra	0..2	0..2	0	0	-
Main 4:2:2 12 Intra	0..2	0..4	0	0	-
Main 4:4:4 Intra	-	0	-	0	-
Main 4:4:4 10 Intra	-	0..2	-	0	-
Main 4:4:4 12 Intra	-	0..4	-	0	-
Main 4:4:4 16 Intra	-	-	-	-	-
Main 4:4:4 Still Picture	-	0	-	0	-
Main 4:4:4 16 Still Picture	-	-	-	-	-

Conformance of a bitstream to the format range extensions profiles is indicated by `general_profile_idc` being equal to 4 or `general_profile_compatibility_flag[4]` being equal to 1 with the additional indications specified in Table A.2. Conformance of a sub-layer representation with `TemporalId` equal to `i` to the format range extensions profiles is indicated by `sub_layer_profile_idc[i]` being equal to 4 or `sub_layer_profile_compatibility_flag[i][4]` being equal to 1 with the additional indications specified in Table A.2, with `general_max_12bit_constraint_flag`, `general_max_10bit_constraint_flag`, `general_max_8bit_constraint_flag`, `general_max_422chroma_constraint_flag`,

general_max_420chroma_constraint_flag, general_max_monochrome_constraint_flag, general_intra_constraint_flag, general_one_picture_only_constraint_flag, and general_lower_bit_rate_constraint_flag replaced by sub_layer_max_12bit_constraint_flag[i], sub_layer_max_10bit_constraint_flag[i], sub_layer_max_8bit_constraint_flag[i], sub_layer_max_422chroma_constraint_flag[i], sub_layer_max_420chroma_constraint_flag[i], sub_layer_max_monochrome_constraint_flag[i], sub_layer_intra_constraint_flag[i], sub_layer_one_picture_only_constraint_flag[i], and sub_layer_lower_bit_rate_constraint_flag[i], respectively.

All other combinations of general_max_12bit_constraint_flag, general_max_10bit_constraint_flag, general_max_8bit_constraint_flag, general_max_422chroma_constraint_flag, general_max_420chroma_constraint_flag, general_max_monochrome_constraint_flag, general_intra_constraint_flag, general_one_picture_only_constraint_flag, and general_lower_bit_rate_constraint_flag with general_profile_idc equal to 4 or general_profile_compatibility_flag[4] equal to 1 are reserved for future use by ITU-T | ISO/IEC. All other combinations of sub_layer_max_12bit_constraint_flag[i], sub_layer_max_10bit_constraint_flag[i], sub_layer_max_8bit_constraint_flag[i], sub_layer_max_422chroma_constraint_flag[i], sub_layer_max_420chroma_constraint_flag[i], sub_layer_max_monochrome_constraint_flag[i], sub_layer_intra_constraint_flag[i], sub_layer_one_picture_only_constraint_flag[i], and sub_layer_lower_bit_rate_constraint_flag[i] with sub_layer_profile_idc[i] equal to 4 or sub_layer_profile_compatibility_flag[i][4] equal to 1 are reserved for future use by ITU-T | ISO/IEC. Such combinations shall not be present in bitstreams conforming to this document. However, decoders conforming to the format range extensions profiles shall allow other combinations as specified below in this subclause to occur in the bitstream.

Table A.2 — Bitstream indications for conformance to format range extensions profiles

Profile for which the bitstream indicates conformance	general_max_12bit_constraint_flag	general_max_10bit_constraint_flag	general_max_8bit_constraint_flag	general_max_422chroma_constraint_flag	general_max_420chroma_constraint_flag	general_max_monochrome_constraint_flag	general_intra_constraint_flag	general_one_picture_only_constraint_flag	general_lower_bit_rate_constraint_flag
Monochrome	1	1	1	1	1	1	0	0	1
Monochrome 12	1	0	0	1	1	1	0	0	1
Monochrome 16	0	0	0	1	1	1	0	0	1
Main 12	1	0	0	1	1	0	0	0	1
Main 4:2:2 10	1	1	0	1	0	0	0	0	1
Main 4:2:2 12	1	0	0	1	0	0	0	0	1
Main 4:4:4	1	1	1	0	0	0	0	0	1
Main 4:4:4 10	1	1	0	0	0	0	0	0	1
Main 4:4:4 12	1	0	0	0	0	0	0	0	1
Main Intra	1	1	1	1	1	0	1	0	0 or 1
Main 10 Intra	1	1	0	1	1	0	1	0	0 or 1
Main 12 Intra	1	0	0	1	1	0	1	0	0 or 1
Main 4:2:2 10 Intra	1	1	0	1	0	0	1	0	0 or 1

Main 4:2:2 12 Intra	1	0	0	1	0	0	1	0	0 or 1
Main 4:4:4 Intra	1	1	1	0	0	0	1	0	0 or 1
Main 4:4:4 10 Intra	1	1	0	0	0	0	1	0	0 or 1
Main 4:4:4 12 Intra	1	0	0	0	0	0	1	0	0 or 1
Main 4:4:4 16 Intra	0	0	0	0	0	0	1	0	0 or 1
Main 4:4:4 Still Picture	1	1	1	0	0	0	1	1	0 or 1
Main 4:4:4 16 Still Picture	0	0	0	0	0	0	1	1	0 or 1

Decoders conforming to a format range extensions profile at a specific level (identified by a specific value of `general_level_idc`) shall be capable of decoding all bitstreams and sub-layer representations for which all of the following conditions apply:

- Any of the following conditions apply:
 - The decoder conforms to the Main 12, Main 4:2:2 10, Main 4:2:2 12, Main 4:4:4, Main 4:4:4 10, or Main 4:4:4 12 profile, and the bitstream or sub-layer representation is indicated to conform to the Main profile or the Main Still Picture profile.
 - The decoder conforms to the Main 12, Main 4:2:2 10, Main 4:2:2 12, Main 4:4:4 10, or Main 4:4:4 12 profile, and the bitstream or sub-layer representation is indicated to conform to the Main 10 profile, the Main profile, or the Main Still Picture profile.
 - The decoder conforms to the Main Intra, Main 10 Intra, Main 12 Intra, Main 4:2:2 10 Intra, Main 4:2:2 12 Intra, Main 4:4:4 Intra, Main 4:4:4 10 Intra, or Main 4:4:4 12 Intra, Main 4:4:4 16 Intra, Main 4:4:4 Still Picture, or Main 4:4:4 16 Still Picture profile, and the bitstream or sub-layer representation is indicated to conform to the Main Still Picture profile.
 - `general_profile_idc` is equal to 4 or `general_profile_compatibility_flag[4]` is equal to 1 for the bitstream, and the value of each constraint flag listed in Table A.2 is greater than or equal to the value(s) specified in the row of Table A.2 for the format range extensions profile for which the decoder conformance is evaluated.
 - `sub_layer_profile_idc[i]` is equal to 4 or `sub_layer_profile_compatibility_flag[i][4]` is equal to 1 for the sub-layer representation, and the value of each constraint flag listed in Table A.2 is greater than or equal to the value(s) specified in the row of Table A.2 for the format range extensions profile for which the decoder conformance is evaluated, with `general_max_12bit_constraint_flag`, `general_max_10bit_constraint_flag`, `general_max_8bit_constraint_flag`, `general_max_422chroma_constraint_flag`, `general_max_420chroma_constraint_flag`, `general_max_monochrome_constraint_flag`, `general_intra_constraint_flag`, `general_one_picture_only_constraint_flag`, and `general_lower_bit_rate_constraint_flag` replaced by `sub_layer_max_12bit_constraint_flag[i]`, `sub_layer_max_10bit_constraint_flag[i]`, `sub_layer_max_8bit_constraint_flag[i]`, `sub_layer_max_422chroma_constraint_flag[i]`, `sub_layer_max_420chroma_constraint_flag[i]`, `sub_layer_max_monochrome_constraint_flag[i]`, `sub_layer_intra_constraint_flag[i]`, `sub_layer_one_picture_only_constraint_flag[i]`, and `sub_layer_lower_bit_rate_constraint_flag[i]`, respectively.
- The bitstream or sub-layer representation is indicated to conform to a level that is not level 8.5 and is lower than or equal to the specified level.
- The bitstream or sub-layer representation is indicated to conform to a tier that is lower than or equal to the specified tier.

ISO/IEC 23008-2:2017(E)

For decoders conforming to the Main Intra, Main 10 Intra, Main 12 Intra, Main 4:2:2 10 Intra, Main 4:2:2 12 Intra, Main Main 4:4:4 Intra, 4:4:4 10 Intra, Main 4:4:4 12 Intra, Main 4:4:4 16 Intra, Main 4:4:4 Still Picture, or Main 4:4:4 16 Still picture profile, the application of either or both of the in-loop filters of the in-loop filter process specified in 8.7 is optional.

A.3.6 High throughput profiles

The following profiles, collectively referred to as the high throughput profiles, are specified in this subclause:

- the High Throughput 4:4:4, High Throughput 4:4:4 10 and High Throughput 4:4:4 14 profiles;
- the High Throughput 4:4:4 16 Intra profile.

NOTE 1 For purposes of this terminology, the screen content coding extensions profiles specified in A.3.7 are not included in the set of profiles that are collectively referred to as the high throughput profiles, although the names of some of the screen content coding extensions profiles include the term “High Throughput”.

Bitstreams conforming to the high throughput profiles shall obey the following constraints:

- Active VPSs shall have `vps_base_layer_internal_flag` and `vps_base_layer_available_flag` both equal to 1 only.
- Active SPSs for the base layer shall have `separate_colour_plane_flag`, `sps_curr_pic_ref_enabled_flag`, `palette_mode_enabled_flag`, `motion_vector_resolution_control_idc`, and `intra_boundary_filtering_disabled_flag`, when present, equal to 0 only.
- In bitstreams conforming to the High Throughput 4:4:4 profile, active SPSs for the base layer shall have `bit_depth_luma_minus8` equal to 0, `bit_depth_chroma_minus8` equal to 0, `extended_precision_processing_flag` equal to 0, and `cabac_bypass_alignment_enabled_flag` equal to 0 only.
- In bitstreams conforming to the High Throughput 4:4:4 10 profile, active SPSs for the base layer shall have `bit_depth_luma_minus8` less than or equal to 2, `bit_depth_chroma_minus8` less than or equal to 2, `extended_precision_processing_flag` equal to 0, and `cabac_bypass_alignment_enabled_flag` equal to 0 only.
- In bitstreams conforming to the High Throughput 4:4:4 14 profile, active SPSs for the base layer shall have `bit_depth_luma_minus8` less than or equal to 6 and `bit_depth_chroma_minus8` less than or equal to 6.
- In bitstreams conforming to the High Throughput 4:4:4 16 Intra profile, active SPSs for the base layer shall have `cabac_bypass_alignment_enabled_flag` equal to 1 only.
- `CtbLog2SizeY` derived according to active SPSs for the base layer shall be in the range of 4 to 6, inclusive.
- Active PPSs for the base layer shall have `residual_adaptive_colour_transform_enabled_flag`, when present, equal to 0 only.
- In bitstreams conforming to the High Throughput 4:4:4, High Throughput 4:4:4 10, or High Throughput 4:4:4 14 profiles, active PPSs for the base layer shall have `entropy_coding_sync_enabled_flag` equal to 1 only.

NOTE 2 Unlike for some other profiles specified in this annex, an active PPS for the base layer for the high throughput profiles may have `tiles_enabled_flag` equal to 1 with `entropy_coding_sync_enabled_flag` equal to 1.

- When an active PPS for the base layer has `tiles_enabled_flag` equal to 1, `ColumnWidthInLumaSamples[i]` shall be greater than or equal to 256 for all values of `i` in the range of 0 to `num_tile_columns_minus1`, inclusive, and `RowHeightInLumaSamples[j]` shall be greater than or equal to 64 for all values of `j` in the range of 0 to `num_tile_rows_minus1`, inclusive.
- In bitstreams conforming to the High Throughput 4:4:4 16 Intra profile, all pictures with `nuh_layer_id` equal to 0 shall be IRAP pictures and the output order indicated in the bitstream among these pictures shall be the same as the decoding order.
- The number of times `read_bits(1)` is called in 9.3.4.3.3 and 9.3.4.3.4 when parsing `coding_tree_unit()` data for any coding tree unit shall be less than or equal to $5 * \text{RawCtuBits} / 3$.
- `general_level_idc` and `sub_layer_level_idc[i]` for all values of `i` in active SPSs for the base layer shall not be equal to 255 (which indicates level 8.5).
- The level constraints specified for the High Throughput 4:4:4, High Throughput 4:4:4 10, High Throughput 4:4:4 14 or High Throughput 4:4:4 16 Intra profile in A.4, as applicable, shall be fulfilled.

Conformance of a bitstream to the high throughput profiles is indicated by `general_profile_idc` being equal to 5 or `general_profile_compatibility_flag[5]` being equal to 1 with the additional indications specified in Table A.3. Conformance of a sub-layer representation with `TemporalId` equal to `i` to the high throughput profiles is indicated by `sub_layer_profile_idc[i]` being equal to 5 or `sub_layer_profile_compatibility_flag[i][5]` being equal to 1 with the additional indications specified in Table A.3, with `general_max_12bit_constraint_flag`, `general_max_10bit_constraint_flag`, `general_max_8bit_constraint_flag`, `general_max_422chroma_constraint_flag`, `general_max_420chroma_constraint_flag`, `general_max_monochrome_constraint_flag`, `general_intra_constraint_flag`, `general_one_picture_only_constraint_flag`, and `general_lower_bit_rate_constraint_flag` being replaced by `sub_layer_max_12bit_constraint_flag[i]`, `sub_layer_max_10bit_constraint_flag[i]`, `sub_layer_max_8bit_constraint_flag[i]`, `sub_layer_max_422chroma_constraint_flag[i]`, `sub_layer_max_420chroma_constraint_flag[i]`, `sub_layer_max_monochrome_constraint_flag[i]`, `sub_layer_intra_constraint_flag[i]`, `sub_layer_one_picture_only_constraint_flag[i]`, and `sub_layer_lower_bit_rate_constraint_flag[i]`, respectively.

All other combinations of `general_max_12bit_constraint_flag`, `general_max_10bit_constraint_flag`, `general_max_8bit_constraint_flag`, `general_max_422chroma_constraint_flag`, `general_max_420chroma_constraint_flag`, `general_max_monochrome_constraint_flag`, `general_intra_constraint_flag`, `general_one_picture_only_constraint_flag`, and `general_lower_bit_rate_constraint_flag` with `general_profile_idc` equal to 5 or `general_profile_compatibility_flag[5]` equal to 1 are reserved for future use by ITU-T | ISO/IEC. All other combinations of `sub_layer_max_12bit_constraint_flag[i]`, `sub_layer_max_10bit_constraint_flag[i]`, `sub_layer_max_8bit_constraint_flag[i]`, `sub_layer_max_422chroma_constraint_flag[i]`, `sub_layer_max_420chroma_constraint_flag[i]`, `sub_layer_max_monochrome_constraint_flag[i]`, `sub_layer_intra_constraint_flag[i]`, `sub_layer_one_picture_only_constraint_flag[i]`, and `sub_layer_lower_bit_rate_constraint_flag[i]`, with `sub_layer_profile_idc[i]` equal to 5 or `sub_layer_profile_compatibility_flag[i][5]` equal to 1 are reserved for future use by ITU-T | ISO/IEC. Such combinations shall not be present in bitstreams conforming to this document. However, decoders conforming to the format range extensions profiles shall allow other combinations as specified below in this subclause to occur in the bitstream.

Table A.3 — Bitstream indications for conformance to high throughput profiles

Profile for which the bitstream indicates conformance	general_max_14bit_constraint_flag	general_max_12bit_constraint_flag	general_max_10bit_constraint_flag	general_max_8bit_constraint_flag	general_max_422chroma_constraint_flag	general_max_420chroma_constraint_flag	general_max_monochrome_constraint_flag	general_intra_constraint_flag	general_one_picture_only_constraint_flag	general_lower_bit_rate_constraint_flag
High Throughput 4:4:4	1	1	1	1	0	0	0	0	0	1
High Throughput 4:4:4 10	1	1	1	0	0	0	0	0	0	1
High Throughput 4:4:4 14	1	0	0	0	0	0	0	0	0	1
High Throughput 4:4:4 16 Intra	0	0	0	0	0	0	0	1	0	0 or 1

Decoders conforming to a high throughput profile at a specific level (identified by a specific value of general_level_idc) shall be capable of decoding all bitstreams or sub-layer representations for which all of the following conditions apply:

- Any of the following conditions apply:
 - general_profile_idc is equal to 5 or general_profile_compatibility_flag[5] is equal to 1 for the bitstream, and the value of each constraint flag listed in Table A.3 is greater than or equal to the value(s) specified in the row of Table A.3 for the high throughput profile for which the decoder conformance is evaluated.
 - sub_layer_profile_idc[i] is equal to 5 or sub_layer_profile_compatibility_flag[i][5] is equal to 1 for the sub-layer representation, and the value of each constraint flag listed in Table A.3 is greater than or equal to the value(s) specified in the row of Table A.3 for the high throughput profile for which the decoder conformance is evaluated, with general_max_14bit_constraint_flag, general_max_12bit_constraint_flag, general_max_10bit_constraint_flag, general_max_8bit_constraint_flag, general_max_422chroma_constraint_flag, general_max_420chroma_constraint_flag, general_max_monochrome_constraint_flag, general_intra_constraint_flag, general_one_picture_only_constraint_flag, and general_lower_bit_rate_constraint_flag being replaced by sub_layer_max_14bit_constraint_flag[i], sub_layer_max_12bit_constraint_flag[i], sub_layer_max_10bit_constraint_flag[i], sub_layer_max_8bit_constraint_flag[i], sub_layer_max_422chroma_constraint_flag[i], sub_layer_max_420chroma_constraint_flag[i], sub_layer_max_monochrome_constraint_flag[i], sub_layer_intra_constraint_flag[i], sub_layer_one_picture_only_constraint_flag[i], and sub_layer_lower_bit_rate_constraint_flag[i], respectively.
- The bitstream or sub-layer representation is indicated to conform to a level that is not level 8.5 and is lower than or equal to the specified level.
- The bitstream or sub-layer representation is indicated to conform to a tier that is lower than or equal to the specified tier.

For decoders conforming to the High Throughput 4:4:4 16 Intra profile, the application of either or both of the in-loop filters of the in-loop filter process specified in 8.7 is optional.

A.3.7 Screen content coding extensions profiles

The following profiles, collectively referred to as the screen content coding extensions profiles, are specified in this subclause:

- the Screen-Extended Main and Screen-Extended Main 10 profiles;
- the Screen-Extended Main 4:4:4 and Screen-Extended Main 4:4:4 10 profiles;
- the Screen-Extended High Throughput 4:4:4, Screen-Extended High Throughput 4:4:4 10, and Screen-Extended High Throughput 14 profiles.

Bitstreams conforming to the screen content coding extensions profiles shall obey the following constraints:

- The constraints specified in Table A.4 shall apply, in which entries marked with "-" indicate that the table entry does not impose a profile-specific constraint on the corresponding syntax element.
- Active VPSs shall have `vps_base_layer_internal_flag` and `vps_base_layer_available_flag` both equal to 1 only.
- Active SPSs for the base layer shall have `separate_colour_plane_flag`, when present, equal to 0 only.
- `CtbLog2SizeY` derived according to active SPSs for the base layer shall be in the range of 4 to 6, inclusive.
- When an active SPS for the base layer has `palette_mode_enabled_flag` equal to 1, `palette_max_size` shall be less than or equal to 64 and `PaletteMaxPredictorSize` shall be less than or equal to 128.
- In bitstreams conforming to the Screen-Extended Main, Screen-Extended Main 10, Screen-Extended Main 4:4:4, Screen-Extended Main 4:4:4 10, Screen-Extended High Throughput 4:4:4 or Screen-Extended High Throughput 4:4:4 10 profiles, active SPSs for the base layer shall have `extended_precision_processing_flag`, and `cabac_bypass_alignment_enabled_flag`, when present, equal to 0 only.
- In bitstreams conforming to the Screen-Extended Main or Screen-Extended Main 10 profiles, when an active PPS for the base layer has `tiles_enabled_flag` equal to 1, it shall have `entropy_coding_sync_enabled_flag` equal to 0.
- In bitstreams conforming to the Screen-Extended High Throughput 4:4:4, Screen-Extended High Throughput 4:4:4 10 or Screen-Extended High Throughput 4:4:4 14 profiles, active PPSs for the base layer shall have `entropy_coding_sync_enabled_flag` equal to 1 only.

NOTE Unlike for some other profiles specified in this annex, an active PPS for the base layer for the Screen-Extended Main 4:4:4, Screen-Extended Main 4:4:4 10, Screen-Extended High Throughput 4:4:4, Screen-Extended High Throughput 4:4:4 10, or Screen-Extended High Throughput 4:4:4 14 profiles may have `tiles_enabled_flag` equal to 1 with `entropy_coding_sync_enabled_flag` equal to 1.

- When an active PPS for the base layer has `tiles_enabled_flag` equal to 1, `ColumnWidthInLumaSamples[i]` shall be greater than or equal to 256 for all values of `i` in the range of 0 to `num_tile_columns_minus1`, inclusive, and `RowHeightInLumaSamples[j]` shall be greater than or equal to 64 for all values of `j` in the range of 0 to `num_tile_rows_minus1`, inclusive.
- The number of times `read_bits(1)` is called in 9.3.4.3.3 and 9.3.4.3.4 when parsing `coding_tree_unit()` data for any coding tree unit shall be less than or equal to $5 * \text{RawCtuBits} / 3$.

ISO/IEC 23008-2:2017(E)

- `general_level_idc` and `sub_layer_level_idc[i]` for all values of `i` in active SPSs for the base layer shall not be equal to 255 (which indicates level 8.5).
- The level constraints specified for the Screen-Extended Main, Screen-Extended Main 10, Screen-Extended Main 4:4:4 or Screen-Extended Main 4:4:4 10 profiles in A.4, as applicable, shall be fulfilled.

Table A.4 — Allowed values for syntax elements in the screen content coding extensions profiles

Profile for which constraint is specified	<code>chroma_format_idc</code>	<code>bit_depth_luma_minus8</code> and <code>bit_depth_chroma_minus8</code>
Screen-Extended Main	1	0
Screen-Extended Main 10	1	0..2
Screen-Extended Main 4:4:4	0, 1, or 3	0
Screen-Extended Main 4:4:4 10	0, 1, or 3	0..2
Screen-Extended High Throughput 4:4:4	–	0
Screen-Extended High Throughput 4:4:4 10	–	0..2
Screen-Extended High Throughput 4:4:4 14	–	0..6

Conformance of a bitstream to the screen content coding extensions profiles is indicated by `general_profile_idc` being equal to 9 or `general_profile_compatibility_flag[9]` being equal to 1 with the additional indications specified in Table A.5. Conformance of a sub-layer representation with TemporalId equal to `i` to the screen content coding extensions profiles is indicated by `sub_layer_profile_idc[i]` being equal to 9 or `sub_layer_profile_compatibility_flag[i][9]` being equal to 1 with the additional indications specified in Table A.5, with `general_max_14bit_constraint_flag`, `general_max_12bit_constraint_flag`, `general_max_10bit_constraint_flag`, `general_max_8bit_constraint_flag`, `general_max_422chroma_constraint_flag`, `general_max_420chroma_constraint_flag`, `general_max_monochrome_constraint_flag`, `general_intra_constraint_flag`, `general_one_picture_only_constraint_flag` and `general_lower_bit_rate_constraint_flag` replaced by `sub_layer_max_12bit_constraint_flag[i]`, `sub_layer_max_10bit_constraint_flag[i]`, `sub_layer_max_8bit_constraint_flag[i]`, `sub_layer_max_422chroma_constraint_flag[i]`, `sub_layer_max_420chroma_constraint_flag[i]`, `sub_layer_max_monochrome_constraint_flag[i]`, `sub_layer_intra_constraint_flag[i]`, `sub_layer_one_picture_only_constraint_flag[i]` and `sub_layer_lower_bit_rate_constraint_flag[i]`, respectively.

All other combinations of `general_max_12bit_constraint_flag`, `general_max_10bit_constraint_flag`, `general_max_8bit_constraint_flag`, `general_max_422chroma_constraint_flag`, `general_max_420chroma_constraint_flag`, `general_max_monochrome_constraint_flag`, `general_intra_constraint_flag`, `general_one_picture_only_constraint_flag` and `general_lower_bit_rate_constraint_flag` with `general_profile_idc` equal to 9 or `general_profile_compatibility_flag[9]` equal to 1 are reserved for future use by ITU-T | ISO/IEC. All other combinations of `sub_layer_max_12bit_constraint_flag[i]`, `sub_layer_max_10bit_constraint_flag[i]`, `sub_layer_max_8bit_constraint_flag[i]`, `sub_layer_max_422chroma_constraint_flag[i]`, `sub_layer_max_420chroma_constraint_flag[i]`, `sub_layer_max_monochrome_constraint_flag[i]`, `sub_layer_intra_constraint_flag[i]`, `sub_layer_one_picture_only_constraint_flag[i]` and `sub_layer_lower_bit_rate_constraint_flag[i]` with `sub_layer_profile_idc[i]` equal to 9 or `sub_layer_profile_compatibility_flag[i][9]` equal to 1 are reserved for future use by ITU-T | ISO/IEC. Such combinations shall not be present in bitstreams conforming to this document. However, decoders conforming to the screen content coding extensions profiles shall allow other combinations as specified below in this subclause to occur in the bitstream.

Table A.5 — Bitstream indications for conformance to screen content coding extensions profiles

Profile for which the bitstream indicates conformance	general_max_14bit_constraint_flag	general_max_12bit_constraint_flag	general_max_10bit_constraint_flag	general_max_8bit_constraint_flag	general_max_422chroma_constraint_flag	general_max_420chroma_constraint_flag	general_max_monochrome_constraint_flag	general_intra_constraint_flag	general_one_picture_only_constraint_flag	general_lower_bit_rate_constraint_flag
Screen-Extended Main	1	1	1	1	1	1	0	0	0	1
Screen-Extended Main 10	1	1	1	0	1	1	0	0	0	1
Screen-Extended Main 4:4:4	1	1	1	1	0	0	0	0	0	1
Screen-Extended Main 4:4:4 10	1	1	1	0	0	0	0	0	0	1
Screen-Extended High Throughput 4:4:4	1	1	1	1	0	0	0	0	0	1
Screen-Extended High Throughput 4:4:4 10	1	1	1	0	0	0	0	0	0	1
Screen-Extended High Throughput 4:4:4 14	1	0	0	0	0	0	0	0	0	1

Decoders conforming to a screen content coding extensions profile at a specific level (identified by a specific value of `general_level_idc`) shall be capable of decoding all bitstreams and sub-layer representations for which all of the following conditions apply:

- Any of the following conditions apply:
 - The bitstream or sub-layer representation is indicated to conform to the Main, Main Still Picture, or Monochrome profile.
 - The decoder conforms to the Screen-Extended Main 10 or Screen-Extended Main 4:4:4 10 profile, and the bitstream or sub-layer representation is indicated to conform to the Main 10 profile.
 - The decoder conforms to the Screen-Extended Main 4:4:4 or Screen-Extended Main 4:4:4 10 profile, and the bitstream or sub-layer representation is indicated to conform to the Main 4:4:4 profile.
 - The decoder conforms to the Screen-Extended Main 4:4:4 10 profile, and the bitstream or sub-layer representation is indicated to conform to the Main 4:4:4 10 profile.
 - The decoder conforms to the Screen-Extended High Throughput 4:4:4, Screen-Extended High Throughput 4:4:4 10, or Screen-Extended High Throughput 4:4:4 14 profile, and the bitstream or sub-layer representation is indicated to conform to the High Throughput 4:4:4 profile.
 - The decoder conforms to the Screen-Extended High Throughput 4:4:4 10 or Screen-Extended High Throughput 4:4:4 14 profile, and the bitstream or sub-layer representation is indicated to conform to the High Throughput 4:4:4 10 profile.

ISO/IEC 23008-2:2017(E)

- The decoder conforms to the Screen-Extended High Throughput 4:4:4 14 profile, and the bitstream or sub-layer representation is indicated to conform to the High Throughput 4:4:4 14 profile.
- The decoder conforms to the Main Intra, Main 10 Intra, Main 12 Intra, Main 4:2:2 10 Intra, Main 4:2:2 12 Intra, Main 4:4:4 Intra, Main 4:4:4 10 Intra, or Main 4:4:4 12 Intra, Main 4:4:4 16 Intra, Main 4:4:4 Still Picture, or Main 4:4:4 16 Still Picture profile, and the bitstream or sub-layer representation is indicated to conform to the Main Still Picture profile.
- `general_profile_idc` is equal to 4 or `general_profile_compatibility_flag[4]` is equal to 1 or `general_profile_idc` is equal to 9 or `general_profile_compatibility_flag[9]` is equal to 1 for the bitstream, and the value of each constraint flag listed in Table A.5 is greater than or equal to the value(s) specified in the row of Table A.5 for the screen content coding extensions profile for which the decoder conformance is evaluated, and `general_max_422chroma_constraint_flag` is equal to `general_max_420chroma_constraint_flag`.
- `sub_layer_profile_idc[i]` is equal to 4 or `sub_layer_profile_compatibility_flag[i][4]` is equal to 1 or `sub_layer_profile_idc[i]` is equal to 9 or `sub_layer_profile_compatibility_flag[i][9]` is equal to 1 for the sub-layer representation, and the value of each constraint flag listed in Table A.5 is greater than or equal to the value(s) specified in the row of Table A.5 for the screen content coding extensions profile for which the decoder conformance is evaluated, and `general_max_422chroma_constraint_flag` is equal to `general_max_420chroma_constraint_flag`, with `general_max_14bit_constraint_flag`, `general_max_12bit_constraint_flag`, `general_max_10bit_constraint_flag`, `general_max_8bit_constraint_flag`, `general_max_422chroma_constraint_flag`, `general_max_420chroma_constraint_flag`, `general_max_monochrome_constraint_flag`, `general_intra_constraint_flag`, `general_one_picture_only_constraint_flag` and `general_lower_bit_rate_constraint_flag` replaced by `sub_layer_max_12bit_constraint_flag[i]`, `sub_layer_max_10bit_constraint_flag[i]`, `sub_layer_max_8bit_constraint_flag[i]`, `sub_layer_max_422chroma_constraint_flag[i]`, `sub_layer_max_420chroma_constraint_flag[i]`, `sub_layer_max_monochrome_constraint_flag[i]`, `sub_layer_intra_constraint_flag[i]`, `sub_layer_one_picture_only_constraint_flag[i]` and `sub_layer_lower_bit_rate_constraint_flag[i]`, respectively.
- The bitstream or sub-layer representation is indicated to conform to a level that is not level 8.5 and is lower than or equal to the specified level.
- The bitstream or sub-layer representation is indicated to conform to a tier that is lower than or equal to the specified tier.

A.4 Tiers and levels

A.4.1 General tier and level limits

For purposes of comparison of tier capabilities, the tier with `general_tier_flag` or `sub_layer_tier_flag[i]` equal to 0 is considered to be a lower tier than the tier with `general_tier_flag` or `sub_layer_tier_flag[i]` equal to 1.

For purposes of comparison of level capabilities, a particular level of a specific tier is considered to be a lower level than some other level of the same tier when the value of the `general_level_idc` or `sub_layer_level_idc[i]` of the particular level is less than that of the other level.

The following is specified for expressing the constraints in this annex:

- Let access unit *n* be the *n*-th access unit in decoding order, with the first access unit being access unit 0 (i.e. the 0-th access unit).

— Let picture n be the coded picture or the corresponding decoded picture of access unit n .

When the specified level is not level 8.5, bitstreams conforming to a profile at a specified tier and level shall obey the following constraints for each bitstream conformance test as specified in Annex C:

- a) PicSizeInSamplesY shall be less than or equal to MaxLumaPs , where MaxLumaPs is specified in Table A.6.
- b) The value of $\text{pic_width_in_luma_samples}$ shall be less than or equal to $\text{Sqrt}(\text{MaxLumaPs} * 8)$.
- c) The value of $\text{pic_height_in_luma_samples}$ shall be less than or equal to $\text{Sqrt}(\text{MaxLumaPs} * 8)$.
- d) For level 5 and higher levels, the value of CtbSizeY shall be equal to 32 or 64.
- e) The value of NumPicTotalCurr shall be less than or equal to 8.
- f) The value of $\text{num_tile_columns_minus1}$ shall be less than MaxTileCols and $\text{num_tile_rows_minus1}$ shall be less than MaxTileRows , where MaxTileCols and MaxTileRows are specified in Table A.6.
- g) For the VCL HRD parameters, $\text{CpbSize}[i]$ shall be less than or equal to $\text{CpbVclFactor} * \text{MaxCPB}$ for at least one value of i in the range of 0 to $\text{cpb_cnt_minus1}[\text{HighestTid}]$, inclusive, where $\text{CpbSize}[i]$ is specified in E.3.3 based on parameters selected as specified in C.1, CpbVclFactor is specified in Table A.8, and MaxCPB is specified in Table A.6 in units of CpbVclFactor bits.
- h) For the NAL HRD parameters, $\text{CpbSize}[i]$ shall be less than or equal to $\text{CpbNalFactor} * \text{MaxCPB}$ for at least one value of i in the range of 0 to $\text{cpb_cnt_minus1}[\text{HighestTid}]$, inclusive, where $\text{CpbSize}[i]$ is specified in E.3.3 based on parameters selected as specified in C.1, CpbNalFactor is specified in Table A.8, and MaxCPB is specified in Table A.6 in units of CpbNalFactor bits.

Table A.6 specifies the limits for each level of each tier for levels other than level 8.5.

A tier and level to which a bitstream conforms are indicated by the syntax elements general_tier_flag and general_level_idc , and a tier and level to which a sub-layer representation conforms are indicated by the syntax elements $\text{sub_layer_tier_flag}[i]$ and $\text{sub_layer_level_idc}[i]$, as follows:

- If the specified level is not level 8.5, general_tier_flag or $\text{sub_layer_tier_flag}[i]$ equal to 0 indicates conformance to the Main tier; general_tier_flag or $\text{sub_layer_tier_flag}[i]$ equal to 1 indicates conformance to the High tier, according to the tier constraints specified in Table A.6, and general_tier_flag and $\text{sub_layer_tier_flag}[i]$ shall be equal to 0 for levels below level 4 (corresponding to the entries in Table A.6 marked with "-"). Otherwise (the specified level is level 8.5), it is a requirement of bitstream conformance that general_tier_flag and $\text{sub_layer_tier_flag}[i]$ shall be equal to 1 and the value 0 for general_tier_flag and $\text{sub_layer_tier_flag}[i]$ is reserved for future use by ITU-T | ISO/IEC, and decoders shall ignore the value of general_tier_flag and $\text{sub_layer_tier_flag}[i]$.
- general_level_idc and $\text{sub_layer_level_idc}[i]$ shall be set equal to a value of 30 times the level number specified in Table A.6.

Table A.6 — General tier and level limits

Level	Max luma picture size MaxLumaPs (samples)	Max CPB size MaxCPB (CpbVclFactor or CpbNalFactor bits)		Max slice segments per picture MaxSlice Segments PerPicture	Max # of tile rows MaxTile Rows	Max # of tile columns MaxTileCols
		Main tier	High tier			
1	36 864	350	—	16	1	1
2	122 880	1 500	—	16	1	1
2.1	245 760	3 000	—	20	1	1
3	552 960	6 000	—	30	2	2
3.1	983 040	10 000	—	40	3	3
4	2 228 224	12 000	30 000	75	5	5
4.1	2 228 224	20 000	50 000	75	5	5
5	8 912 896	25 000	100 000	200	11	10
5.1	8 912 896	40 000	160 000	200	11	10
5.2	8 912 896	60 000	240 000	200	11	10
6	35 651 584	60 000	240 000	600	22	20
6.1	35 651 584	120 000	480 000	600	22	20
6.2	35 651 584	240 000	800 000	600	22	20

A.4.2 Profile-specific level limits for the video profiles

NOTE Video profiles refer to those profiles that are not still picture profiles. The still picture profiles include the Main Still Picture profile, the Main 4:4:4 Still Picture profile, and the Main 4:4:4 16 Still Picture profile.

The following is specified for expressing the constraints in this annex:

- Let the variable fR be set equal to 1 ÷ 300.

The variable HbrFactor is defined as follows:

- If the bitstream or sub-layer representation is indicated to conform to the Main profile or the Main 10 profile, HbrFactor is set equal to 1.
- Otherwise, if the bitstream or sub-layer representation is indicated to conform to the High Throughput 4:4:4, High Throughput 4:4:4 10, High Throughput 4:4:4 14, Screen-Extended High Throughput 4:4:4, Screen-Extended High Throughput 4:4:4 10, or Screen-Extended High Throughput 4:4:4 14 profile, HbrFactor is set equal to 6.
- Otherwise, if the bitstream or sub-layer representation is indicated to conform to the High Throughput 4:4:4 16 Intra profile, HbrFactor is set equal to $24 - (12 * \text{general_lower_bit_rate_constraint_flag})$ or $24 - (12 * \text{sub_layer_lower_bit_rate_constraint_flag}[i])$.
- Otherwise, HbrFactor is set equal to $2 - \text{general_lower_bit_rate_constraint_flag}$ or $2 - \text{sub_layer_lower_bit_rate_constraint_flag}[i]$.

The variable BrVclFactor, which represents the VCL bit rate scale factor, is set equal to CpbVclFactor * HbrFactor.

The variable $BrNalFactor$, which represents the NAL bit rate scale factor, is set equal to $CpbNalFactor * HbrFactor$.

The variable $MinCr$ is set equal to $MinCrBase * MinCrScaleFactor \div HbrFactor$.

When the specified level is not level 8.5, the value of $sps_max_dec_pic_buffering_minus1[HighestTid] + 1$ shall be less than or equal to $MaxDpbSize$, which is derived as follows:

```

if( PicSizeInSamplesY <= ( MaxLumaPs >> 2 ) )
    MaxDpbSize = Min( 4 * maxDpbPicBuf, 16 )
else if( PicSizeInSamplesY <= ( MaxLumaPs >> 1 ) )
    MaxDpbSize = Min( 2 * maxDpbPicBuf, 16 )
else if( PicSizeInSamplesY <= ( ( 3 * MaxLumaPs ) >> 2 ) )
    MaxDpbSize = Min( ( 4 * maxDpbPicBuf ) / 3, 16 )
else
    MaxDpbSize = maxDpbPicBuf

```

(A-2)

where $MaxLumaPs$ is specified in Table A.6, and $maxDpbPicBuf$ is equal to 6 for all profiles where the value of $sps_curr_pic_ref_enabled_flag$ is required to be equal to 0 and 7 for all profiles where the value of $sps_curr_pic_ref_enabled_flag$ is not required to be equal to 0.

Bitstreams and sub-layer representations conforming to the Monochrome, Monochrome 12, Monochrome 16, Main, Main 10, Main 12, Main 4:2:2 10, Main 4:2:2 12, Main 4:4:4 10, Main 4:4:4 12, Main Intra, Main 10 Intra, Main 12 Intra, Main 4:2:2 10 Intra, Main 4:2:2 12 Intra, Main 4:4:4 10 Intra, Main 4:4:4 12 Intra, Main 4:4:4 16 Intra, High Throughput 4:4:4, High Throughput 4:4:4 10, High Throughput 4:4:4 14, High Throughput 4:4:4 16 Intra, Screen-Extended Main, Screen-Extended Main 10, Screen-Extended Main 4:4:4, Screen-Extended Main 4:4:4 10, Screen-Extended High Throughput 4:4:4, Screen-Extended High Throughput 4:4:4 10, or Screen-Extended High Throughput 4:4:4 14 profile at a specified tier and level shall obey the following constraints for each bitstream conformance test as specified in Annex C.

- a) The nominal removal time of access unit n (with n greater than 0) from the CPB, as specified in C.2.3, shall satisfy the constraint that $AuNominalRemovalTime[n] - AuCpbRemovalTime[n - 1]$ is greater than or equal to $Max(PicSizeInSamplesY \div MaxLumaSr, fR)$ for the value of $PicSizeInSamplesY$ of picture $n - 1$, where $MaxLumaSr$ is the value specified in Table A.7 that applies to picture $n - 1$.
- b) The difference between consecutive output times of pictures from the DPB, as specified in C.3.3, shall satisfy the constraint that $DpbOutputInterval[n]$ is greater than or equal to $Max(PicSizeInSamplesY \div MaxLumaSr, fR)$ for the value of $PicSizeInSamplesY$ of picture n , where $MaxLumaSr$ is the value specified in Table A.7 for picture n , provided that picture n is a picture that is output and is not the last picture of the bitstream that is output.
- c) The removal time of access unit 0 shall satisfy the constraint that the number of slice segments in picture 0 is less than or equal to $Min(Max(1, MaxSliceSegmentsPerPicture * MaxLumaSr / MaxLumaPs * (AuCpbRemovalTime[0] - AuNominalRemovalTime[0]) + MaxSliceSegmentsPerPicture * PicSizeInSamplesY / MaxLumaPs), MaxSliceSegmentsPerPicture)$, for the value of $PicSizeInSamplesY$ of picture 0, where $MaxSliceSegmentsPerPicture$, $MaxLumaPs$ and $MaxLumaSr$ are the values specified in Table A.6 and Table A.7, respectively, that apply to picture 0.
- d) The difference between consecutive CPB removal times of access units n and $n - 1$ (with n greater than 0) shall satisfy the constraint that the number of slice segments in picture n is less than or equal to $Min(Max(1, MaxSliceSegmentsPerPicture * MaxLumaSr / MaxLumaPs * (AuCpbRemovalTime[n] - AuCpbRemovalTime[n - 1])), MaxSliceSegmentsPerPicture)$, where $MaxSliceSegmentsPerPicture$, $MaxLumaPs$, and $MaxLumaSr$ are the values specified in Table A.6 and Table A.7 that apply to picture n .

ISO/IEC 23008-2:2017(E)

- e) For the VCL HRD parameters, $BitRate[i]$ shall be less than or equal to $BrVclFactor * MaxBR$ for at least one value of i in the range of 0 to $cpb_cnt_minus1[HighestTid]$, inclusive, where $BitRate[i]$ is specified in E.3.3 based on parameters selected as specified in C.1 and $MaxBR$ is specified in Table A.7 in units of $BrVclFactor$ bits/s.
- f) For the NAL HRD parameters, $BitRate[i]$ shall be less than or equal to $BrNalFactor * MaxBR$ for at least one value of i in the range of 0 to $cpb_cnt_minus1[HighestTid]$, inclusive, where $BitRate[i]$ is specified in E.3.3 based on parameters selected as specified in C.1 and $MaxBR$ is specified in Table A.7 in units of $BrNalFactor$ bits/s.
- g) The sum of the $NumBytesInNalUnit$ variables for access unit 0 shall be less than or equal to $FormatCapabilityFactor * (Max(PicSizeInSamplesY, fR * MaxLumaSr) + MaxLumaSr * (AuCpbRemovalTime[0] - AuNominalRemovalTime[0])) \div MinCr$ for the value of $PicSizeInSamplesY$ of picture 0, where $MaxLumaSr$ and $FormatCapabilityFactor$ are the values specified in Table A.7 and Table A.8, respectively, that apply to picture 0.
- h) The sum of the $NumBytesInNalUnit$ variables for access unit n (with n greater than 0) shall be less than or equal to $FormatCapabilityFactor * MaxLumaSr * (AuCpbRemovalTime[n] - AuCpbRemovalTime[n - 1]) \div MinCr$, where $MaxLumaSr$ and $FormatCapabilityFactor$ are the values specified in Table A.7 and Table A.8, respectively, that apply to picture n .
- i) The removal time of access unit 0 shall satisfy the constraint that the number of tiles in picture 0 is less than or equal to $Min(Max(1, MaxTileCols * MaxTileRows * 120 * (AuCpbRemovalTime[0] - AuNominalRemovalTime[0]) + MaxTileCols * MaxTileRows * PicSizeInSamplesY / MaxLumaPs), MaxTileCols * MaxTileRows)$, for the value of $PicSizeInSamplesY$ of picture 0, where $MaxTileCols$ and $MaxTileRows$ are the values specified in Table A.6 that apply to picture 0.
- j) The difference between consecutive CPB removal times of access units n and $n - 1$ (with n greater than 0) shall satisfy the constraint that the number of tiles in picture n is less than or equal to $Min(Max(1, MaxTileCols * MaxTileRows * 120 * (AuCpbRemovalTime[n] - AuCpbRemovalTime[n - 1])), MaxTileCols * MaxTileRows)$, where $MaxTileCols$ and $MaxTileRows$ are the values specified in Table A.6 that apply to picture n .

Table A.7 — Tier and level limits for the video profiles

Level	Max luma sample rate $MaxLumaSr$ (samples/sec)	Max bit rate $MaxBR$ ($BrVclFactor$ or $BrNalFactor$ bits/s)		Min compression ratio $MinCrBase$	
		Main tier	High tier	Main tier	High tier
1	552 960	128	-	2	2
2	3 686 400	1 500	-	2	2
2.1	7 372 800	3 000	-	2	2
3	16 588 800	6 000	-	2	2
3.1	33 177 600	10 000	-	2	2
4	66 846 720	12 000	30 000	4	4
4.1	133 693 440	20 000	50 000	4	4
5	267 386 880	25 000	100 000	6	4

5.1	534 773 760	40 000	160 000	8	4
5.2	1 069 547 520	60 000	240 000	8	4
6	1 069 547 520	60 000	240 000	8	4
6.1	2 139 095 040	120 000	480 000	8	4
6.2	4 278 190 080	240 000	800 000	6	4

Table A.8 — Specification of CpbVclFactor, CpbNalFactor, FormatCapabilityFactor, and MinCrScaleFactor

Profile	CpbVclFactor	CpbNalFactor	FormatCapabilityFactor	MinCrScaleFactor
Monochrome	667	733	1.000	1.0
Monochrome 12	1000	1100	1.500	1.0
Monochrome 16	1333	1467	2.000	1.0
Main	1000	1100	1.500	1.0
Screen-Extended Main	1000	1100	1.500	1.0
Main 10	1000	1100	1.875	1.0
Screen-Extended Main 10	1000	1100	1.875	1.0
Main 12	1500	1650	2.250	1.0
Main Still Picture	1000	1100	1.500	1.0
Main 4:2:2 10	1667	1833	2.500	0.5
Main 4:2:2 12	2000	2200	3.000	0.5
Main 4:4:4	2000	2200	3.000	0.5
High Throughput 4:4:4	2000	2200	3.000	0.5
Screen-Extended Main 4:4:4	2000	2200	3.000	0.5
Screen-Extended High Throughput 4:4:4	2000	2200	3.000	0.5
Main 4:4:4 10	2500	2750	3.750	0.5
High Throughput 4:4:4 10	2500	2750	3.750	0.5
Screen-Extended Main 4:4:4 10	2500	2750	3.750	0.5
Screen-Extended High Throughput 4:4:4 10	2500	2750	3.750	0.5
Main 4:4:4 12	3000	3300	4.500	0.5
High Throughput 4:4:4 14	3500	3850	5.250	0.5
Screen-Extended High Throughput 4:4:4 14	3500	3850	5.250	0.5

Main Intra	1000	1100	1.500	1.0
Main 10 Intra	1000	1100	1.875	1.0
Main 12 Intra	1500	1650	2.250	1.0
Main 4:2:2 10 Intra	1667	1833	2.500	0.5
Main 4:2:2 12 Intra	2000	2200	3.000	0.5
Main 4:4:4 Intra	2000	2200	3.000	0.5
Main 4:4:4 10 Intra	2500	2750	3.750	0.5
Main 4:4:4 12 Intra	3000	3300	4.500	0.5
Main 4:4:4 16 Intra	4000	4400	6.000	0.5
Main 4:4:4 Still Picture	2000	2200	3.000	0.5
Main 4:4:4 16 Still Picture	4000	4400	6.000	0.5
High Throughput 4:4:4 16 Intra	4000	4400	6.000	0.5

A.4.3 shows the effect of these limits on picture rates for several example picture formats.

A.4.3 Effect of level limits on picture rate for the video profiles (informative)

This subclause does not form an integral part of this document.

Informative Tables A.9 and A.10 provide examples of maximum picture rates for the Monochrome, Monochrome 12, Monochrome 16, Main, Main 10, Main 12, Main 4:2:2 10, Main 4:2:2 12, Main 4:4:4, Main 4:4:4 10, Main 4:4:4 12, Main Intra, Main 10 Intra, Main 12 Intra, Main 4:2:2 10 Intra, Main 4:2:2 12 Intra, Main 4:4:4 Intra, Main 4:4:4 10 Intra, Main 4:4:4 12 Intra, Main 4:4:4 16 Intra and High Throughput 4:4:4 16 Intra profiles for various picture formats when MinCbSizeY is equal to 64.

Table A.9 — Maximum picture rates (pictures per second) at level 1 to 4.1 for some example picture sizes when MinCbSizeY is equal to 64

Level:				1	2	2.1	3	3.1	4	4.1
Max luma picture size (samples):				36 864	122 880	245 760	552 960	983 040	2 228 224	2 228 224
Max luma sample rate (samples/sec)				552 960	3 686 400	7 372 800	16 588 800	33 177 600	66 846 720	133 693 440
Format nickname	Luma width	Luma height	Luma picture size							
SQCIF	128	96	16 384	33.7	225.0	300.0	300.0	300.0	300.0	300.0
QCIF	176	144	36 864	15.0	100.0	200.0	300.0	300.0	300.0	300.0
QVGA	320	240	81 920	-	45.0	90.0	202.5	300.0	300.0	300.0
525 SIF	352	240	98 304	-	37.5	75.0	168.7	300.0	300.0	300.0
CIF	352	288	122 880	-	30.0	60.0	135.0	270.0	300.0	300.0
525 HHR	352	480	196 608	-	-	37.5	84.3	168.7	300.0	300.0
625 HHR	352	576	221 184	-	-	33.3	75.0	150.0	300.0	300.0
Q720p	640	360	245 760	-	-	30.0	67.5	135.0	272.0	300.0
VGA	640	480	327 680	-	-	-	50.6	101.2	204.0	300.0
525 4SIF	704	480	360 448	-	-	-	46.0	92.0	185.4	300.0

525 SD	720	480	393 216	-	-	-	42.1	84.3	170.0	300.0
4CIF	704	576	405 504	-	-	-	40.9	81.8	164.8	300.0
625 SD	720	576	442 368	-	-	-	37.5	75.0	151.1	300.0
480p (16:9)	864	480	458 752	-	-	-	36.1	72.3	145.7	291.4
SVGA	800	600	532 480	-	-	-	31.1	62.3	125.5	251.0
QHD	960	540	552 960	-	-	-	30.0	60.0	120.8	241.7
XGA	1024	768	786 432	-	-	-	-	42.1	85.0	170.0
720p HD	1280	720	983 040	-	-	-	-	33.7	68.0	136.0
4VGA	1280	960	1 228 800	-	-	-	-	-	54.4	108.8
SXGA	1280	1024	1 310 720	-	-	-	-	-	51.0	102.0
525 16SIF	1408	960	1 351 680	-	-	-	-	-	49.4	98.9
16CIF	1408	1152	1 622 016	-	-	-	-	-	41.2	82.4
4SVGA	1600	1200	1 945 600	-	-	-	-	-	34.3	68.7
1080 HD	1920	1080	2 088 960	-	-	-	-	-	32.0	64.0
2Kx1K	2048	1024	2 097 152	-	-	-	-	-	31.8	63.7
2Kx1080	2048	1080	2 228 224	-	-	-	-	-	30.0	60.0
4XGA	2048	1536	3 145 728	-	-	-	-	-	-	-
16VGA	2560	1920	4 915 200	-	-	-	-	-	-	-
3616x1536 (2.35:1)	3616	1536	5 603 328	-	-	-	-	-	-	-
3672x1536 (2.39:1)	3680	1536	5 701 632	-	-	-	-	-	-	-
3840x2160 (4*HD)	3840	2160	8 355 840	-	-	-	-	-	-	-
4Kx2K	4096	2048	8 388 608	-	-	-	-	-	-	-
4096x2160	4096	2160	8 912 896	-	-	-	-	-	-	-
4096x2304 (16:9)	4096	2304	9 437 184	-	-	-	-	-	-	-
7680x4320	7680	4320	33 423 360	-	-	-	-	-	-	-
8192x4096	8192	4096	33 554 432	-	-	-	-	-	-	-
8192x4320	8192	4320	35 651 584	-	-	-	-	-	-	-

Table A.10 — Maximum picture rates (pictures per second) at level 5 to 6.2 for some example picture sizes when MinCbSizeY is equal to 64

Level:				5	5.1	5.2	6	6.1	6.2
Max luma picture size (samples):				8 912 896	8 912 896	8 912 896	35 651 584	35 651 584	35 651 584
Max luma sample rate (samples/sec)				267 386 880	534 773 760	1 069 547 520	1 069 547 520	2 139 095 040	4 278 190 080
Format nickname	Luma width	Luma height	Luma picture size						
SQCIF	128	96	16 384	300.0	300.0	300.0	300.0	300.0	300.0
QCIF	176	144	36 864	300.0	300.0	300.0	300.0	300.0	300.0
QVGA	320	240	81 920	300.0	300.0	300.0	300.0	300.0	300.0
525 SIF	352	240	98 304	300.0	300.0	300.0	300.0	300.0	300.0

ISO/IEC 23008-2:2017(E)

CIF	352	288	122 880	300.0	300.0	300.0	300.0	300.0	300.0
525 HHR	352	480	196 608	300.0	300.0	300.0	300.0	300.0	300.0
625 HHR	352	576	221 184	300.0	300.0	300.0	300.0	300.0	300.0
Q720p	640	360	245 760	300.0	300.0	300.0	300.0	300.0	300.0
VGA	640	480	327 680	300.0	300.0	300.0	300.0	300.0	300.0
525 4SIF	704	480	360 448	300.0	300.0	300.0	300.0	300.0	300.0
525 SD	720	480	393 216	300.0	300.0	300.0	300.0	300.0	300.0
4CIF	704	576	405 504	300.0	300.0	300.0	300.0	300.0	300.0
625 SD	720	576	442 368	300.0	300.0	300.0	300.0	300.0	300.0
480p (16:9)	864	480	458 752	300.0	300.0	300.0	300.0	300.0	300.0
SVGA	800	600	532 480	300.0	300.0	300.0	300.0	300.0	300.0
QHD	960	540	552 960	300.0	300.0	300.0	300.0	300.0	300.0
XGA	1024	768	786 432	300.0	300.0	300.0	300.0	300.0	300.0
720p HD	1280	720	983 040	272.0	300.0	300.0	300.0	300.0	300.0
4VGA	1280	960	1 228 800	217.6	300.0	300.0	300.0	300.0	300.0
SXGA	1280	1024	1 310 720	204.0	300.0	300.0	300.0	300.0	300.0
525 16SIF	1408	960	1 351 680	197.8	300.0	300.0	300.0	300.0	300.0
16CIF	1408	1152	1 622 016	164.8	300.0	300.0	300.0	300.0	300.0
4SVGA	1600	1200	1 945 600	137.4	274.8	300.0	300.0	300.0	300.0
1080 HD	1920	1080	2 088 960	128.0	256.0	300.0	300.0	300.0	300.0
2Kx1K	2048	1024	2 097 152	127.5	255.0	300.0	300.0	300.0	300.0
2Kx1080	2048	1080	2 228 224	120.0	240.0	300.0	300.0	300.0	300.0
4XGA	2048	1536	3 145 728	85.0	170.0	300.0	300.0	300.0	300.0
16VGA	2560	1920	4 915 200	54.4	108.8	217.6	217.6	300.0	300.0
3616x1536 (2.35:1)	3616	1536	5 603 328	47.7	95.4	190.8	190.8	300.0	300.0
3672x1536 (2.39:1)	3680	1536	5 701 632	46.8	93.7	187.5	187.5	300.0	300.0
3840x2160 (4*HD)	3840	2160	8 355 840	32.0	64.0	128.0	128.0	256.0	300.0
4Kx2K	4096	2048	8 388 608	31.8	63.7	127.5	127.5	255.0	300.0
4096x2160	4096	2160	8 912 896	30.0	60.0	120.0	120.0	240.0	300.0
4096x2304 (16:9)	4096	2304	9 437 184	-	-	-	113.3	226.6	300.0
4096x3072	4096	3072	12 582 912	-	-	-	85.0	170.0	300.0
7680x4320	7680	4320	33 423 360	-	-	-	32.0	64.0	128.0
8192x4096	8192	4096	33 554 432	-	-	-	31.8	63.7	127.5
8192x4320	8192	4320	35 651 584	-	-	-	30.0	60.0	120.0

The following should be noted in regard to the examples shown in Tables A.9 and A.10:

- This is a variable-picture-size Specification. The specific listed picture sizes are illustrative examples only.
- The example luma picture sizes were computed by rounding up the luma width and luma height to multiples of 64 before computing the product of these quantities, to reflect the potential use of MinCbSizeY equal to 64 for these picture sizes, as pic_width_in_luma_samples and pic_height_in_luma_samples are each required to be a multiple of MinCbSizeY. For some illustrated values of luma width and luma height, a somewhat higher number of pictures per second can be supported when MinCbSizeY is less than 64.
- In cases where the maximum picture rate value is not an integer multiple of 0.1 pictures per second, the given maximum picture rate values have been rounded down to the largest integer multiple of 0.1 frames per second that does not exceed the exact value. For example, for level 3.1, the maximum picture rate for 720p HD has been rounded down to 33.7 from an exact value of 33.75.
- As used in the examples, “525” refers to typical use for environments using 525 analogue scan lines (of which approximately 480 lines contain the visible picture region), and “625” refers to environments using 625 analogue scan lines (of which approximately 576 lines contain the visible picture region).
- XGA is also known as (aka) XVGA, 4SVGA aka UXGA, 16XGA aka 4Kx3K, CIF aka 625 SIF, 625 HHR aka 2CIF aka half 625 D-1, aka half 625 ITU-R BT.601, 525 SD aka 525 D-1 aka 525 ITU-R BT.601, 625 SD aka 625 D-1 aka 625 ITU-R BT.601.

STANDARDSISO.COM : Click to view the full PDF of ISO/IEC 23008-2:2017

Annex B
(normative)

Byte stream format

B.1 General

This annex specifies syntax and semantics of a byte stream format specified for use by applications that deliver some or all of the NAL unit stream as an ordered stream of bytes or bits within which the locations of NAL unit boundaries need to be identifiable from patterns in the data, such as Rec. ITU-T H.222.0 | ISO/IEC 13818-1 systems or Rec. ITU-T H.320 systems. For bit-oriented delivery, the bit order for the byte stream format is specified to start with the MSB of the first byte, proceed to the LSB of the first byte, followed by the MSB of the second byte, etc.

The byte stream format consists of a sequence of byte stream NAL unit syntax structures. Each byte stream NAL unit syntax structure contains one start code prefix followed by one nal_unit(NumBytesInNalUnit) syntax structure. It may (and under some circumstances, it shall) also contain an additional zero_byte syntax element. It may also contain one or more additional trailing_zero_8bits syntax elements. When it is the first byte stream NAL unit in the bitstream, it may also contain one or more additional leading_zero_8bits syntax elements.

B.2 Byte stream NAL unit syntax and semantics

B.2.1 Byte stream NAL unit syntax

byte_stream_nal_unit(NumBytesInNalUnit) {	Descriptor
while(next_bits(24) != 0x000001 && next_bits(32) != 0x00000001)	
leading_zero_8bits /* equal to 0x00 */	f(8)
if(next_bits(24) != 0x000001)	
zero_byte /* equal to 0x00 */	f(8)
start_code_prefix_one_3bytes /* equal to 0x000001 */	f(24)
nal_unit(NumBytesInNalUnit)	
while(more_data_in_byte_stream() && next_bits(24) != 0x000001 && next_bits(32) != 0x00000001)	
trailing_zero_8bits /* equal to 0x00 */	f(8)
}	

B.2.2 Byte stream NAL unit semantics

The order of byte stream NAL units in the byte stream shall follow the decoding order of the NAL units contained in the byte stream NAL units (see 7.4.2.4). The content of each byte stream NAL unit is associated with the same access unit as the NAL unit contained in the byte stream NAL unit (see 7.4.2.4.4).

leading_zero_8bits is a byte equal to 0x00.

NOTE The leading_zero_8bits syntax element can only be present in the first byte stream NAL unit of the bitstream, because (as shown in the syntax diagram of B.2.1) bytes equal to 0x00 that follow a NAL unit syntax structure and precede the four-byte sequence 0x00000001 (which is to be interpreted as a zero_byte followed by a start_code_prefix_one_3bytes) will be considered to be trailing_zero_8bits syntax elements that are part of the preceding byte stream NAL unit.

zero_byte is a single byte equal to 0x00.

When one or more of the following conditions are true, the zero_byte syntax element shall be present:

- The nal_unit_type within the nal_unit() syntax structure is equal to VPS_NUT, SPS_NUT or PPS_NUT.
- The byte stream NAL unit syntax structure contains the first NAL unit of an access unit in decoding order, as specified in 7.4.2.4.4.

start_code_prefix_one_3bytes is a fixed-value sequence of 3 bytes equal to 0x000001. This syntax element is called a start code prefix.

trailing_zero_8bits is a byte equal to 0x00.

B.3 Byte stream NAL unit decoding process

Input to this process consists of an ordered stream of bytes consisting of a sequence of byte stream NAL unit syntax structures.

Output of this process consists of a sequence of NAL unit syntax structures.

At the beginning of the decoding process, the decoder initializes its current position in the byte stream to the beginning of the byte stream. It then extracts and discards each leading_zero_8bits syntax element (when present), moving the current position in the byte stream forward one byte at a time, until the current position in the byte stream is such that the next four bytes in the bitstream form the four-byte sequence 0x00000001.

The decoder then performs the following step-wise process repeatedly to extract and decode each NAL unit syntax structure in the byte stream until the end of the byte stream has been encountered (as determined by unspecified means) and the last NAL unit in the byte stream has been decoded:

1. When the next four bytes in the bitstream form the four-byte sequence 0x00000001, the next byte in the byte stream (which is a zero_byte syntax element) is extracted and discarded and the current position in the byte stream is set equal to the position of the byte following this discarded byte.
2. The next three-byte sequence in the byte stream (which is a start_code_prefix_one_3bytes) is extracted and discarded and the current position in the byte stream is set equal to the position of the byte following this three-byte sequence.
3. NumBytesInNalUnit is set equal to the number of bytes starting with the byte at the current position in the byte stream up to and including the last byte that precedes the location of one or more of the following conditions:
 - a subsequent byte-aligned three-byte sequence equal to 0x000000;
 - a subsequent byte-aligned three-byte sequence equal to 0x000001;
 - the end of the byte stream, as determined by unspecified means.
4. NumBytesInNalUnit bytes are removed from the bitstream and the current position in the byte stream is advanced by NumBytesInNalUnit bytes. This sequence of bytes is nal_unit(NumBytesInNalUnit) and is decoded using the NAL unit decoding process.
5. When the current position in the byte stream is not at the end of the byte stream (as determined by unspecified means) and the next bytes in the byte stream do not start with a three-byte sequence equal to 0x000001 and the next bytes in the byte stream do not start with a four byte sequence equal to 0x00000001, the decoder extracts and discards each trailing_zero_8bits syntax element, moving the current position in the byte stream forward one byte at a time, until the current

position in the byte stream is such that the next bytes in the byte stream form the four-byte sequence 0x00000001 or the end of the byte stream has been encountered (as determined by unspecified means).

B.4 Decoder byte-alignment recovery (informative)

This clause does not form an integral part of this document.

Many applications provide data to a decoder in a manner that is inherently byte aligned, and thus have no need for the bit-oriented byte alignment detection procedure described in this clause.

A decoder is said to have byte alignment with a bitstream when the decoder has determined whether or not the positions of data in the bitstream are byte-aligned. When a decoder does not have byte alignment with the bitstream, the decoder may examine the incoming bitstream for the binary pattern '00000000 00000000 00000000 00000001' (31 consecutive bits equal to 0 followed by a bit equal to 1). The bit immediately following this pattern is the first bit of an aligned byte following a start code prefix. Upon detecting this pattern, the decoder will be byte-aligned with the bitstream and positioned at the start of a NAL unit in the bitstream.

Once byte aligned with the bitstream, the decoder can examine the incoming bitstream data for subsequent three-byte sequences 0x000001 and 0x000003.

When the three-byte sequence 0x000001 is detected, this is a start code prefix.

When the three-byte sequence 0x000003 is detected, the third byte (0x03) is an emulation_prevention_three_byte to be discarded as specified in 7.4.2.

When an error in the bitstream syntax is detected (e.g. a non-zero value of the forbidden_zero_bit or one of the three-byte or four-byte sequences that are prohibited in 7.4.2), the decoder may consider the detected condition as an indication that byte alignment may have been lost and may discard all bitstream data until the detection of byte alignment at a later position in the bitstream as described above in this clause.

STANDARDSISO.COM : Click to view the full PDF of ISO/IEC 23008-2:2017

Annex C (normative)

Hypothetical reference decoder

C.1 General

This annex specifies the hypothetical reference decoder (HRD) and its use to check bitstream and decoder conformance.

Two types of bitstreams or bitstream subsets are subject to HRD conformance checking for this document. The first type, called a Type I bitstream, is a NAL unit stream containing only the VCL NAL units and NAL units with `nal_unit_type` equal to `FD_NUT` (filler data NAL units) for all access units in the bitstream. The second type, called a Type II bitstream, contains, in addition to the VCL NAL units and filler data NAL units for all access units in the bitstream, at least one of the following:

- additional non-VCL NAL units other than filler data NAL units;
- all `leading_zero_8bits`, `zero_byte`, `start_code_prefix_one_3bytes`, and `trailing_zero_8bits` syntax elements that form a byte stream from the NAL unit stream (as specified in Annex B).

Figure C.1 shows the types of bitstream conformance points checked by the HRD.

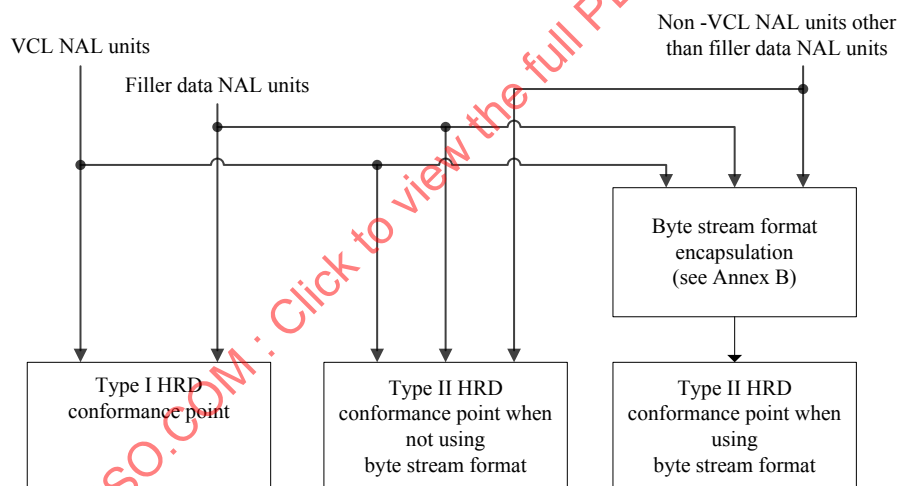

Figure C.1 — Structure of byte streams and NAL unit streams for HRD conformance checks

The syntax elements of non-VCL NAL units (or their default values for some of the syntax elements), required for the HRD, are specified in the semantic clauses of Clause 7, Annexes D and E.

Two types of HRD parameter sets (NAL HRD parameters and VCL HRD parameters) are used. The HRD parameter sets are signalled through the `hrd_parameters()` syntax structure, which may be part of the SPS syntax structure or the VPS syntax structure.

Two sets of bitstream conformance tests are needed for checking the conformance of a bitstream, which is referred to as the entire bitstream, denoted as `entireBitstream`. The first set of bitstream conformance tests are for testing the conformance of the entire bitstream and its temporal subsets, regardless of whether there is a layer set specified by the active VPS that contains all the `nuh_layer_id` values of VCL NAL units present in the entire bitstream. The second set of bitstream conformance tests are for testing the conformance of the layer sets specified by the active VPS and their temporal subsets.

ISO/IEC 23008-2:2017(E)

For all these tests, only the base layer pictures (i.e. pictures with `nuh_layer_id` equal to 0) are decoded and other pictures are ignored by the decoder when the decoding process is invoked.

For each test, the following ordered steps apply in the order listed, followed by the processes described after these steps in this clause.

1. An operation point under test, denoted as `TargetOp`, is selected by selecting a layer identifier list `OpLayerIdList` and a target highest TemporalId value `OpTid`. The layer identifier list `OpLayerIdList` of `TargetOp` either consists of all the `nuh_layer_id` values of the VCL NAL units present in `entireBitstream` or consists of all the `nuh_layer_id` values of a layer set specified by the active VPS. The value of `OpTid` is in the range of 0 to `sps_max_sub_layers_minus1`, inclusive. The values of `OpLayerIdList` and `OpTid` are such that the sub-bitstream `BitstreamToDecode` that is the output by invoking the sub-bitstream extraction process as specified in Clause 10 with `entireBitstream`, `OpTid`, and `OpLayerIdList` as inputs satisfy both of the following conditions:
 - There is at least one VCL NAL unit in `BitstreamToDecode` with `nuh_layer_id` equal to each of the `nuh_layer_id` values in `OpLayerIdList`.
 - There is at least one VCL NAL unit with TemporalId equal to `OpTid` in `BitstreamToDecode`.
2. `TargetDecLayerIdList` is set equal to `OpLayerIdList` of `TargetOp` and `HighestTid` is set equal to `OpTid` of `TargetOp`.
3. The `hrd_parameters()` syntax structure and the `sub_layer_hrd_parameters()` syntax structure applicable to `TargetOp` are selected. If `TargetDecLayerIdList` contains all `nuh_layer_id` values present in `entireBitstream`, the `hrd_parameters()` syntax structure in the active SPS (or provided through an external means not specified in this document) is selected. Otherwise, the `hrd_parameters()` syntax structure in the active VPS (or provided through some external means not specified in this document) that applies to `TargetOp` is selected. Within the selected `hrd_parameters()` syntax structure, if `BitstreamToDecode` is a Type I bitstream, the `sub_layer_hrd_parameters(HighestTid)` syntax structure that immediately follows the condition "`if(vcl_hrd_parameters_present_flag)`" is selected and the variable `NalHrdModeFlag` is set equal to 0; otherwise (`BitstreamToDecode` is a Type II bitstream), the `sub_layer_hrd_parameters(HighestTid)` syntax structure that immediately follows either the condition "`if(vcl_hrd_parameters_present_flag)`" (in this case the variable `NalHrdModeFlag` is set equal to 0) or the condition "`if(nal_hrd_parameters_present_flag)`" (in this case the variable `NalHrdModeFlag` is set equal to 1) is selected. When `BitstreamToDecode` is a Type II bitstream and `NalHrdModeFlag` is equal to 0, all non-VCL NAL units except filler data NAL units, and all `leading_zero_8bits`, `zero_byte`, `start_code_prefix_one_3bytes`, and `trailing_zero_8bits` syntax elements that form a byte stream from the NAL unit stream (as specified in Annex B), when present, are discarded from `BitstreamToDecode`, and the remaining bitstream is assigned to `BitstreamToDecode`.
4. An access unit associated with a buffering period SEI message (present in `BitstreamToDecode` or available through external means not specified in this document) applicable to `TargetOp` is selected as the HRD initialization point and referred to as access unit 0. If `TargetDecLayerIdList` contains all `nuh_layer_id` values present in `entireBitstream`, the associated buffering period SEI message shall be either a non-nested SEI message or provided by external means. Otherwise, the associated buffering period SEI message shall be either a nested SEI message or provided by external means.
5. When `sub_pic_hrd_params_present_flag` in the selected `hrd_parameters()` syntax structure is equal to 1, the CPB is scheduled to operate either at the access unit level (in which case the variable `SubPicHrdFlag` is set equal to 0) or at the sub-picture level (in which case the variable `SubPicHrdFlag` is set equal to 1). Otherwise, `SubPicHrdFlag` is set equal to 0 and the CPB is scheduled to operate at the partition unit level.

6. For each access unit in BitstreamToDecode starting from access unit 0, the buffering period SEI message (present in BitstreamToDecode or available through external means not specified in this document) that is associated with the access unit and applies to TargetOp is selected, the picture timing SEI message (present in BitstreamToDecode or available through external means not specified in this document) that is associated with the access unit and applies to TargetOp is selected, and when SubPicHrdFlag is equal to 1 and sub_pic_cpb_params_in_pic_timing_sei_flag is equal to 0, the decoding unit information SEI messages (present in BitstreamToDecode or available through external means not specified in this document) that are associated with decoding units in the access unit and apply to TargetOp are selected. If TargetDecLayerIdList contains all nuh_layer_id values present in entireBitstream, the selected buffering period, picture timing, and decoding unit information SEI messages shall be either non-nested SEI messages or provided by external means. Otherwise, the selected buffering period, picture timing, and decoding unit information SEI messages shall be either nested SEI messages or provided by external means.
7. A value of SchedSelIdx is selected. The selected SchedSelIdx shall be in the range of 0 to cpb_cnt_minus1[HighestTid], inclusive, where cpb_cnt_minus1[HighestTid] is found in the hrd_parameters() syntax structure as selected above.
8. When the coded picture in access unit 0 has nal_unit_type equal to CRA_NUT or BLA_W_LP, and irap_cpb_params_present_flag in the selected buffering period SEI message is equal to 1, either of the following applies for selection of the initial CPB removal delay and delay offset:
 - If NalHrdModeFlag is equal to 1, the default initial CPB removal delay and delay offset represented by nal_initial_cpb_removal_delay[SchedSelIdx] and nal_initial_cpb_removal_offset[SchedSelIdx], respectively, in the selected buffering period SEI message are selected. Otherwise, the default initial CPB removal delay and delay offset represented by vcl_initial_cpb_removal_delay[SchedSelIdx] and vcl_initial_cpb_removal_offset[SchedSelIdx], respectively, in the selected buffering period SEI message are selected. The variable DefaultInitCpbParamsFlag is set equal to 1.
 - If NalHrdModeFlag is equal to 0, the alternative initial CPB removal delay and delay offset represented by nal_initial_alt_cpb_removal_delay[SchedSelIdx] and nal_initial_alt_cpb_removal_offset[SchedSelIdx], respectively, in the selected buffering period SEI message are selected. Otherwise, the alternative initial CPB removal delay and delay offset represented by vcl_initial_alt_cpb_removal_delay[SchedSelIdx] and vcl_initial_alt_cpb_removal_offset[SchedSelIdx], respectively, in the selected buffering period SEI message are selected. The variable DefaultInitCpbParamsFlag is set equal to 0, and the RASL access units associated with access unit 0 are discarded from BitstreamToDecode and the remaining bitstream is assigned to BitstreamToDecode.

Each conformance test consists of a combination of one option in each of the above steps. When there is more than one option for a step, for any particular conformance test only one option is chosen. All possible combinations of all the steps form the entire set of conformance tests.

For each operation point under test, the number of bitstream conformance tests to be performed is equal to $n_0 * n_1 * (n_2 * 2 + n_3) * n_4$, where the values of n_0 , n_1 , n_2 , n_3 , and n_4 are specified as follows:

- n_0 is derived as follows:
 - If BitstreamToDecode is a Type I bitstream, n_0 is equal to 1.
 - Otherwise (BitstreamToDecode is a Type II bitstream), n_0 is equal to 2.
- n_1 is equal to cpb_cnt_minus1[HighestTid] + 1.

ISO/IEC 23008-2:2017(E)

- n_2 is the number of access units in BitstreamToDecode that each is associated with a buffering period SEI message applicable to TargetOp and for each of which both of the following conditions are true:
 - `nal_unit_type` is equal to `CRA_NUT` or `BLA_W_LP` for the VCL NAL units.
 - The associated buffering period SEI message applicable to TargetOp has `irap_cpb_params_present_flag` equal to 1.
- n_3 is the number of access units in BitstreamToDecode that each is associated with a buffering period SEI message applicable to TargetOp and for each of which one or both of the following conditions are true:
 - `nal_unit_type` is equal to neither `CRA_NUT` nor `BLA_W_LP` for the VCL NAL units.
 - The associated buffering period SEI message applicable to TargetOp has `irap_cpb_params_present_flag` equal to 0.
- n_4 is derived as follows:
 - If `sub_pic_hrd_params_present_flag` in the selected `hrd_parameters()` syntax structure is equal to 0, n_4 is equal to 1.
 - Otherwise, n_4 is equal to 2.

When BitstreamToDecode is a Type II bitstream, the following apply:

- If the `sub_layer_hrd_parameters(HighestTid)` syntax structure that immediately follows the condition "`if(vcl_hrd_parameters_present_flag)`" is selected, the test is conducted at the Type I conformance point shown in Figure C.1, and only VCL and filler data NAL units are counted for the input bit rate and CPB storage.
- Otherwise (the `sub_layer_hrd_parameters(HighestTid)` syntax structure that immediately follows the condition "`if(nal_hrd_parameters_present_flag)`" is selected), the test is conducted at the Type II conformance point shown in Figure C.1, and all bytes of the Type II bitstream, which may be a NAL unit stream or a byte stream, are counted for the input bit rate and CPB storage.

NOTE 1 NAL HRD parameters established by a value of `SchedSelIdx` for the Type II conformance point shown in Figure C.1 are sufficient to also establish VCL HRD conformance for the Type I conformance point shown in Figure C.1 for the same values of `InitCpbRemovalDelay[SchedSelIdx]`, `BitRate[SchedSelIdx]`, and `CpbSize[SchedSelIdx]` for the VBR case (`cbr_flag[SchedSelIdx]` equal to 0). This is because the data flow into the Type I conformance point is a subset of the data flow into the Type II conformance point and because, for the VBR case, the CPB is allowed to become empty and stay empty until the time a next picture is scheduled to begin to arrive. For example, when decoding a CVS conforming to one or more of the profiles specified in Annex A using the decoding process specified in Clauses 2 through 10, when NAL HRD parameters are provided for the Type II conformance point that not only fall within the bounds set for NAL HRD parameters for profile conformance in item f) of A.4.2 but also fall within the bounds set for VCL HRD parameters for profile conformance in item e) of A.4.2, conformance of the VCL HRD for the Type I conformance point is also assured to fall within the bounds of item e) of A.4.2.

All VPSs, SPSs and PPSs referred to in the VCL NAL units, and the corresponding buffering period, picture timing and decoding unit information SEI messages shall be conveyed to the HRD, in a timely manner, either in the bitstream (by non-VCL NAL units), or by other means not specified in this document.

In Annexes C, D, and E, the specification for "presence" of non-VCL NAL units that contain VPSs, SPSs, PPSs, buffering period SEI messages, picture timing SEI messages, or decoding unit information SEI messages is also satisfied when those NAL units (or just some of them) are conveyed to decoders (or to

the HRD) by other means not specified in this document. For the purpose of counting bits, only the appropriate bits that are actually present in the bitstream are counted.

NOTE 2 As an example, synchronization of such a non-VCL NAL unit, conveyed by means other than presence in the bitstream, with the NAL units that are present in the bitstream, can be achieved by indicating two points in the bitstream, between which the non-VCL NAL unit would have been present in the bitstream, had the encoder decided to convey it in the bitstream.

When the content of such a non-VCL NAL unit is conveyed for the application by some means other than presence within the bitstream, the representation of the content of the non-VCL NAL unit is not required to use the same syntax as specified in this document.

NOTE 3 When HRD information is contained within the bitstream, it is possible to verify the conformance of a bitstream to the requirements of this clause based solely on information contained in the bitstream. When the HRD information is not present in the bitstream, as is the case for all “stand-alone” Type I bitstreams, conformance can only be verified when the HRD data are supplied by some other means not specified in this document.

The HRD contains a coded picture buffer (CPB), an instantaneous decoding process, a decoded picture buffer (DPB), and output cropping as shown in Figure C.2.

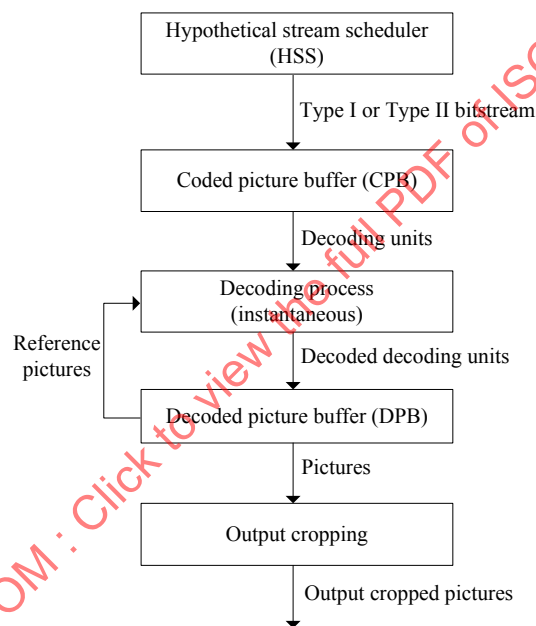

Figure C.2 — HRD buffer model

For each bitstream conformance test, the CPB size (number of bits) is $CpbSize[SchedSelIdx]$ as specified in E.3.3, where $SchedSelIdx$ and the HRD parameters are specified above in this clause. The DPB size (number of picture storage buffers) is $sps_max_dec_pic_buffering_minus1[HighestTid] + 1$.

If $SubPicHrdFlag$ is equal to 0, the HRD operates at access unit level and each decoding unit is an access unit. Otherwise, the HRD operates at sub-picture level and each decoding unit is a subset of an access unit.

NOTE 4 If the HRD operates at access unit level, each time when some bits are removed from the CPB, a decoding unit that is an entire access unit is removed from the CPB. Otherwise (the HRD operates at sub-picture level), each time when some bits are removed from the CPB, a decoding unit that is a subset of an access unit is removed from the CPB. Regardless of whether the HRD operates at access unit level or sub-picture level, each time when some picture is output from the DPB, an entire decoded picture is output from the DPB, though the picture output time is derived based on the differently derived CPB removal times and the differently signalled DPB output delays.

ISO/IEC 23008-2:2017(E)

The following is specified for expressing the constraints in this annex:

- Each access unit is referred to as access unit n , where the number n identifies the particular access unit. Access unit 0 is selected per step 4 above. The value of n is incremented by 1 for each subsequent access unit in decoding order.
- Each decoding unit is referred to as decoding unit m , where the number m identifies the particular decoding unit. The first decoding unit in decoding order in access unit 0 is referred to as decoding unit 0. The value of m is incremented by 1 for each subsequent decoding unit in decoding order.

NOTE 5 The numbering of decoding units is relative to the first decoding unit in access unit 0.

- Picture n refers to the coded picture or the decoded picture of access unit n .

The HRD operates as follows:

- The HRD is initialized at decoding unit 0, with both the CPB and the DPB being set to be empty (the DPB fullness is set equal to 0).

NOTE 6 After initialization, the HRD is not initialized again by subsequent buffering period SEI messages.

- Data associated with decoding units that flow into the CPB according to a specified arrival schedule are delivered by the HSS.
- The data associated with each decoding unit are removed and decoded instantaneously by the instantaneous decoding process at the CPB removal time of the decoding unit.
- Each decoded picture is placed in the DPB.
- A decoded picture is removed from the DPB when it becomes no longer needed for inter prediction reference and no longer needed for output.

For each bitstream conformance test, the operation of the CPB is specified in C.2, the instantaneous decoder operation is specified in Clauses 2 through 10, the operation of the DPB is specified in C.3, and the output cropping is specified in C.3.3 and C.5.2.2.

HSS and HRD information concerning the number of enumerated delivery schedules and their associated bit rates and buffer sizes is specified in E.2.2 and E.3.2. The HRD is initialized as specified by the buffering period SEI message specified in D.2.2 and D.3.2. The removal timing of decoding units from the CPB and output timing of decoded pictures from the DPB is specified using information in picture timing SEI messages (specified in D.2.3 and D.3.3) or in decoding unit information SEI messages (specified in D.2.22 and D.3.22). All timing information relating to a specific decoding unit shall arrive prior to the CPB removal time of the decoding unit.

The requirements for bitstream conformance are specified in C.4, and the HRD is used to check conformance of bitstreams as specified above in this clause and to check conformance of decoders as specified in C.5.

NOTE 7 While conformance is guaranteed under the assumption that all picture-rates and clocks used to generate the bitstream match exactly the values signalled in the bitstream, in a real system each of these may vary from the signalled or specified value.

All the arithmetic in this annex is performed with real values, so that no rounding errors can propagate. For example, the number of bits in a CPB just prior to or after removal of a decoding unit is not necessarily an integer.

The variable ClockTick is derived as follows and is called a clock tick:

$$\text{ClockTick} = \text{vui_num_units_in_tick} \div \text{vui_time_scale} \quad (\text{C-1})$$

The variable ClockSubTick is derived as follows and is called a clock sub-tick:

$$\text{ClockSubTick} = \text{ClockTick} \div (\text{tick_divisor_minus2} + 2) \quad (\text{C-2})$$

C.2 Operation of coded picture buffer (CPB)

C.2.1 General

The specifications in this clause apply independently to each set of CPB parameters that is present and to both the Type I and Type II conformance points shown in Figure C.1, and the set of CPB parameters is selected as specified in C.1.

C.2.2 Timing of decoding unit arrival

If SubPicHrdFlag is equal to 0, the variable subPicParamsFlag is set equal to 0, and the process in specified in the remainder of this clause is invoked with a decoding unit being considered as an access unit, for derivation of the initial and final CPB arrival times for access unit n.

Otherwise (SubPicHrdFlag is equal to 1), the process in specified in the remainder of this clause is first invoked with the variable subPicParamsFlag set equal to 0 and a decoding unit being considered as an access unit, for derivation of the initial and final CPB arrival times for access unit n, and then invoked with subPicParamsFlag set equal to 1 and a decoding unit being considered as a subset of an access unit, for derivation of the initial and final CPB arrival times for the decoding units in access unit n.

The variables InitCpbRemovalDelay[SchedSelIdx] and InitCpbRemovalDelayOffset[SchedSelIdx] are derived as follows:

- If one or more of the following conditions are true, InitCpbRemovalDelay[SchedSelIdx] and InitCpbRemovalDelayOffset[SchedSelIdx] are set equal to the values of the buffering period SEI message syntax elements nal_initial_alt_cpb_removal_delay[SchedSelIdx] and nal_initial_alt_cpb_removal_offset[SchedSelIdx], respectively, when NalHrdModeFlag is equal to 1, or vcl_initial_alt_cpb_removal_delay[SchedSelIdx] and vcl_initial_alt_cpb_removal_offset[SchedSelIdx], respectively, when NalHrdModeFlag is equal to 0, where the buffering period SEI message syntax elements are selected as specified in C.1:
 - Access unit 0 is a BLA access unit for which the coded picture has nal_unit_type equal to BLA_W_RADL or BLA_N_LP, and the value of irap_cpb_params_present_flag of the buffering period SEI message is equal to 1.
 - Access unit 0 is a BLA access unit for which the coded picture has nal_unit_type equal to BLA_W_LP or is a CRA access unit, and the value of irap_cpb_params_present_flag of the buffering period SEI message is equal to 1, and one or more of the following conditions are true:
 - UseAltCpbParamsFlag for access unit 0 is equal to 1.
 - DefaultInitCpbParamsFlag is equal to 0.
- The value of subPicParamsFlag is equal to 1.
- Otherwise, InitCpbRemovalDelay[SchedSelIdx] and InitCpbRemovalDelayOffset[SchedSelIdx] are set equal to the values of the buffering period SEI message syntax elements nal_initial_cpb_removal_delay[SchedSelIdx] and nal_initial_cpb_removal_offset[SchedSelIdx], respectively, when NalHrdModeFlag is equal to 1, or vcl_initial_cpb_removal_delay[SchedSelIdx] and vcl_initial_cpb_removal_offset[SchedSelIdx], respectively, when NalHrdModeFlag is equal to 0, where the buffering period SEI message syntax elements are selected as specified in C.1.

ISO/IEC 23008-2:2017(E)

The time at which the first bit of decoding unit m begins to enter the CPB is referred to as the initial arrival time $\text{initArrivalTime}[m]$.

The initial arrival time of decoding unit m is derived as follows:

- If the decoding unit is decoding unit 0 (i.e. when m is equal to 0), $\text{initArrivalTime}[0]$ is set equal to 0.
- Otherwise (the decoding unit is decoding unit m with $m > 0$), the following apply:
 - If $\text{cbr_flag}[\text{SchedSelIdx}]$ is equal to 1, the initial arrival time for decoding unit m is equal to the final arrival time (which is derived below) of decoding unit $m - 1$, i.e.

```
if( !subPicParamsFlag )
    initArrivalTime[ m ] = AuFinalArrivalTime[ m - 1 ]
else
    initArrivalTime[ m ] = DuFinalArrivalTime[ m - 1 ]
```

 (C-3)

- Otherwise ($\text{cbr_flag}[\text{SchedSelIdx}]$ is equal to 0), the initial arrival time for decoding unit m is derived as follows:

```
if( !subPicParamsFlag )
    initArrivalTime[ m ] = Max( AuFinalArrivalTime[ m - 1 ], initArrivalEarliestTime[ m ] )
else
    initArrivalTime[ m ] = Max( DuFinalArrivalTime[ m - 1 ], initArrivalEarliestTime[ m ] )
```

 (C-4)

where $\text{initArrivalEarliestTime}[m]$ is derived as follows:

- The variable $\text{tmpNominalRemovalTime}$ is derived as follows:

```
if( !subPicParamsFlag )
    tmpNominalRemovalTime = AuNominalRemovalTime[ m ]
else
    tmpNominalRemovalTime = DuNominalRemovalTime[ m ]
```

 (C-5)

where $\text{AuNominalRemovalTime}[m]$ and $\text{DuNominalRemovalTime}[m]$ are the nominal CPB removal time of access unit m and decoding unit m , respectively, as specified in C.2.3.

- If decoding unit m is not the first decoding unit of a subsequent buffering period, $\text{initArrivalEarliestTime}[m]$ is derived as follows:

```
initArrivalEarliestTime[ m ] = tmpNominalRemovalTime - ( InitCpbRemovalDelay[ SchedSelIdx ]
    + InitCpbRemovalDelayOffset[ SchedSelIdx ] ) ÷ 90000
```

 (C-6)

- Otherwise (decoding unit m is the first decoding unit of a subsequent buffering period), $\text{initArrivalEarliestTime}[m]$ is derived as follows:

```
initArrivalEarliestTime[ m ] = tmpNominalRemovalTime -
    ( InitCpbRemovalDelay[ SchedSelIdx ] ÷ 90000 )
```

 (C-7)

The final arrival time for decoding unit m is derived as follows:

```
if( !subPicParamsFlag )
    AuFinalArrivalTime[ m ] = initArrivalTime[ m ] + sizeInbits[ m ] ÷ BitRate[ SchedSelIdx ]
else
    DuFinalArrivalTime[ m ] = initArrivalTime[ m ] + sizeInbits[ m ] ÷ BitRate[ SchedSelIdx ]
```

 (C-8)

where $\text{sizeInbits}[m]$ is the size in bits of decoding unit m , counting the bits of the VCL NAL units and the filler data NAL units for the Type I conformance point or all bits of the Type II bitstream for the Type II conformance point, where the Type I and Type II conformance points are as shown in Figure C.1.

The values of SchedSelIdx , $\text{BitRate}[\text{SchedSelIdx}]$, and $\text{CpbSize}[\text{SchedSelIdx}]$ are constrained as follows:

- If the content of the selected $\text{hrd_parameters}()$ syntax structures for the access unit containing decoding unit m and the previous access unit differ, the HSS selects a value SchedSelIdx1 of SchedSelIdx from among the values of SchedSelIdx provided in the selected $\text{hrd_parameters}()$ syntax structures for the access unit containing decoding unit m that results in a $\text{BitRate}[\text{SchedSelIdx1}]$ or $\text{CpbSize}[\text{SchedSelIdx1}]$ for the access unit containing decoding unit m . The value of $\text{BitRate}[\text{SchedSelIdx1}]$ or $\text{CpbSize}[\text{SchedSelIdx1}]$ may differ from the value of $\text{BitRate}[\text{SchedSelIdx0}]$ or $\text{CpbSize}[\text{SchedSelIdx0}]$ for the value SchedSelIdx0 of SchedSelIdx that was in use for the previous access unit.
- Otherwise, the HSS continues to operate with the previous values of SchedSelIdx , $\text{BitRate}[\text{SchedSelIdx}]$ and $\text{CpbSize}[\text{SchedSelIdx}]$.

When the HSS selects values of $\text{BitRate}[\text{SchedSelIdx}]$ or $\text{CpbSize}[\text{SchedSelIdx}]$ that differ from those of the previous access unit, the following apply:

- The variable $\text{BitRate}[\text{SchedSelIdx}]$ comes into effect at the initial CPB arrival time of the current access unit.
- The variable $\text{CpbSize}[\text{SchedSelIdx}]$ comes into effect as follows:
 - If the new value of $\text{CpbSize}[\text{SchedSelIdx}]$ is greater than the old CPB size, it comes into effect at the initial CPB arrival time of the current access unit.
 - Otherwise, the new value of $\text{CpbSize}[\text{SchedSelIdx}]$ comes into effect at the CPB removal time of the current access unit.

C.2.3 Timing of decoding unit removal and decoding of decoding unit

The variables $\text{InitCpbRemovalDelay}[\text{SchedSelIdx}]$, $\text{InitCpbRemovalDelayOffset}[\text{SchedSelIdx}]$, CpbDelayOffset , and DpbDelayOffset are derived as follows:

- If one or more of the following conditions are true, CpbDelayOffset is set equal to the value of the buffering period SEI message syntax element cpb_delay_offset , DpbDelayOffset is set equal to the value of the buffering period SEI message syntax element dpb_delay_offset , and $\text{InitCpbRemovalDelay}[\text{SchedSelIdx}]$ and $\text{InitCpbRemovalDelayOffset}[\text{SchedSelIdx}]$ are set equal to the values of the buffering period SEI message syntax elements $\text{nal_initial_alt_cpb_removal_delay}[\text{SchedSelIdx}]$ and $\text{nal_initial_alt_cpb_removal_offset}[\text{SchedSelIdx}]$, respectively, when NalHrdModeFlag is equal to 1, or $\text{vcl_initial_alt_cpb_removal_delay}[\text{SchedSelIdx}]$ and $\text{vcl_initial_alt_cpb_removal_offset}[\text{SchedSelIdx}]$, respectively, when NalHrdModeFlag is equal to 0, where the buffering period SEI message containing the syntax elements is selected as specified in C.1:
 - Access unit 0 is a BLA access unit for which the coded picture has nal_unit_type equal to BLA_W_RADL or BLA_N_LP , and the value of $\text{irap_cpb_params_present_flag}$ of the buffering period SEI message is equal to 1.
 - Access unit 0 is a BLA access unit for which the coded picture has nal_unit_type equal to BLA_W_LP or is a CRA access unit, and the value of $\text{irap_cpb_params_present_flag}$ of the

buffering period SEI message is equal to 1, and one or more of the following conditions are true:

- UseAltCpbParamsFlag for access unit 0 is equal to 1.
- DefaultInitCpbParamsFlag is equal to 0.
- Otherwise, InitCpbRemovalDelay[SchedSelIdx] and InitCpbRemovalDelayOffset[SchedSelIdx] are set equal to the values of the buffering period SEI message syntax elements nal_initial_cpb_removal_delay[SchedSelIdx] and nal_initial_cpb_removal_offset[SchedSelIdx], respectively, when NalHrdModeFlag is equal to 1, or vcl_initial_cpb_removal_delay[SchedSelIdx] and vcl_initial_cpb_removal_offset[SchedSelIdx], respectively, when NalHrdModeFlag is equal to 0, where the buffering period SEI message containing the syntax elements is selected as specified in C.1, CpbDelayOffset and DpbDelayOffset are both set equal to 0.

The nominal removal time of the access unit n from the CPB is specified as follows:

- If access unit n is the access unit with n equal to 0 (the access unit that initializes the HRD), the nominal removal time of the access unit from the CPB is specified by:

$$\text{AuNominalRemovalTime}[0] = \text{InitCpbRemovalDelay}[\text{SchedSelIdx}] + 90000 \quad (\text{C-9})$$

- Otherwise, the following applies:

- When access unit n is the first access unit of a buffering period that does not initialize the HRD, the following applies:

The nominal removal time of the access unit n from the CPB is specified by:

$$\begin{aligned} & \text{if} (\text{!concatenationFlag}) \{ \\ & \quad \text{baseTime} = \text{AuNominalRemovalTime}[\text{firstPicInPrevBuffPeriod}] \\ & \quad \text{tmpCpbRemovalDelay} = \text{AuCpbRemovalDelayVal} \\ & \} \text{ else } \{ \\ & \quad \text{baseTime} = \text{AuNominalRemovalTime}[\text{prevNonDiscardablePic}] \\ & \quad \text{tmpCpbRemovalDelay} = \\ & \quad \quad \text{Max}((\text{auCpbRemovalDelayDeltaMinus1} + 1), \\ & \quad \quad \text{Ceil}((\text{InitCpbRemovalDelay}[\text{SchedSelIdx}] \div 90000 + \\ & \quad \quad \text{AuFinalArrivalTime}[n - 1] - \text{AuNominalRemovalTime}[n - 1]) \div \text{ClockTick})) \\ & \} \\ & \text{AuNominalRemovalTime}[n] = \text{baseTime} + \text{ClockTick} * (\text{tmpCpbRemovalDelay} - \\ & \quad \text{CpbDelayOffset}) \end{aligned} \quad (\text{C-10})$$

where AuNominalRemovalTime[firstPicInPrevBuffPeriod] is the nominal removal time of the first access unit of the previous buffering period,

AuNominalRemovalTime[prevNonDiscardablePic] is the nominal removal time of the preceding picture in decoding order with TemporalId equal to 0 that is not a RASL, RADL, or SLNR picture, AuCpbRemovalDelayVal is the value of AuCpbRemovalDelayVal derived according to au_cpb_removal_delay_minus1 in the picture timing SEI message, selected as specified in C.1, associated with access unit n, and concatenationFlag and auCpbRemovalDelayDeltaMinus1 are the values of the syntax elements concatenation_flag and au_cpb_removal_delay_delta_minus1, respectively, in the buffering period SEI message, selected as specified in C.1, associated with access unit n.

After the derivation of the nominal CPB removal time and before the derivation of the DPB output time of access unit n , the values of $CpbDelayOffset$ and $DpbDelayOffset$ are updated as follows:

- If one or more of the following conditions are true, $CpbDelayOffset$ is set equal to the value of the buffering period SEI message syntax element cpb_delay_offset , and $DpbDelayOffset$ is set equal to the value of the buffering period SEI message syntax element dpb_delay_offset , where the buffering period SEI message containing the syntax elements is selected as specified in C.1:
 - Access unit n is a BLA access unit for which the coded picture has nal_unit_type equal to BLA_W_RADL or BLA_N_LP , and the value of $irap_cpb_params_present_flag$ of the buffering period SEI message is equal to 1.
 - Access unit n is a BLA access unit for which the coded picture has nal_unit_type equal to BLA_W_LP or is a CRA access unit, and the value of $irap_cpb_params_present_flag$ of the buffering period SEI message is equal to 1, and $UseAltCpbParamsFlag$ for access unit n is equal to 1.
- Otherwise, $CpbDelayOffset$ and $DpbDelayOffset$ are both set equal to 0.
- When access unit n is not the first access unit of a buffering period, the nominal removal time of the access unit n from the CPB is specified by:

$$AuNominalRemovalTime[n] = AuNominalRemovalTime[firstPicInCurrBuffPeriod] + \text{ClockTick} * (AuCpbRemovalDelayVal - CpbDelayOffset) \quad (C-11)$$

where $AuNominalRemovalTime[firstPicInCurrBuffPeriod]$ is the nominal removal time of the first access unit of the current buffering period, and $AuCpbRemovalDelayVal$ is the value of $AuCpbRemovalDelayVal$ derived according to $au_cpb_removal_delay_minus1$ in the picture timing SEI message, selected as specified in C.1, associated with access unit n .

When $SubPicHrdFlag$ is equal to 1, the following apply:

- The variable $duCpbRemovalDelayInc$ is derived as follows:
 - If $sub_pic_cpb_params_in_pic_timing_sei_flag$ is equal to 0, $duCpbRemovalDelayInc$ is set equal to the value of $du_spt_cpb_removal_delay_increment$ in the decoding unit information SEI message, selected as specified in C.1, associated with decoding unit m .
 - Otherwise, if $du_common_cpb_removal_delay_flag$ is equal to 0, $duCpbRemovalDelayInc$ is set equal to the value of $du_cpb_removal_delay_increment_minus1[i] + 1$ for decoding unit m in the picture timing SEI message, selected as specified in C.1, associated with access unit n , where the value of i is 0 for the first $num_nalus_in_du_minus1[0] + 1$ consecutive NAL units in the access unit that contains decoding unit m , 1 for the subsequent $num_nalus_in_du_minus1[1] + 1$ NAL units in the same access unit, 2 for the subsequent $num_nalus_in_du_minus1[2] + 1$ NAL units in the same access unit, etc.
 - Otherwise, $duCpbRemovalDelayInc$ is set equal to the value of $du_common_cpb_removal_delay_increment_minus1 + 1$ in the picture timing SEI message, selected as specified in C.1, associated with access unit n .
- The nominal removal time of decoding unit m from the CPB is specified as follows, where $AuNominalRemovalTime[n]$ is the nominal removal time of access unit n :
 - If decoding unit m is the last decoding unit in access unit n , the nominal removal time of decoding unit m $DuNominalRemovalTime[m]$ is set equal to $AuNominalRemovalTime[n]$.

ISO/IEC 23008-2:2017(E)

- Otherwise (decoding unit m is not the last decoding unit in access unit n), the nominal removal time of decoding unit m $DuNominalRemovalTime[m]$ is derived as follows:

```
if( sub_pic_cpb_params_in_pic_timing_sei_flag )
    DuNominalRemovalTime[ m ] = DuNominalRemovalTime[ m + 1 ] -
        ClockSubTick * duCpbRemovalDelayInc
else
    DuNominalRemovalTime[ m ] = AuNominalRemovalTime[ n ] -
        ClockSubTick * duCpbRemovalDelayInc
```

(C-12)

If $SubPicHrdFlag$ is equal to 0, the removal time of access unit n from the CPB is specified as follows, where $AuFinalArrivalTime[n]$ and $AuNominalRemovalTime[n]$ are the final CPB arrival time and nominal CPB removal time, respectively, of access unit n :

```
if( !low_delay_hrd_flag[ HighestTid ] || AuNominalRemovalTime[ n ] >= AuFinalArrivalTime[ n ] )
    AuCpbRemovalTime[ n ] = AuNominalRemovalTime[ n ]
else
    AuCpbRemovalTime[ n ] = AuNominalRemovalTime[ n ] + ClockTick *
        Ceil( ( AuFinalArrivalTime[ n ] - AuNominalRemovalTime[ n ] ) ÷ ClockTick )
```

(C-13)

NOTE 1 When $low_delay_hrd_flag[HighestTid]$ is equal to 1 and $AuNominalRemovalTime[n]$ is less than $AuFinalArrivalTime[n]$, the size of access unit n is so large that it prevents removal at the nominal removal time.

Otherwise ($SubPicHrdFlag$ is equal to 1), the removal time of decoding unit m from the CPB is specified as follows:

```
if( !low_delay_hrd_flag[ HighestTid ] || DuNominalRemovalTime[ m ] >= DuFinalArrivalTime[ m ] )
    DuCpbRemovalTime[ m ] = DuNominalRemovalTime[ m ]
else
    DuCpbRemovalTime[ m ] = DuFinalArrivalTime[ m ]
```

(C-14)

NOTE 2 When $low_delay_hrd_flag[HighestTid]$ is equal to 1 and $DuNominalRemovalTime[m]$ is less than $DuFinalArrivalTime[m]$, the size of decoding unit m is so large that it prevents removal at the nominal removal time.

If $SubPicHrdFlag$ is equal to 0, at the CPB removal time of access unit n , the access unit is instantaneously decoded.

Otherwise ($SubPicHrdFlag$ is equal to 1), at the CPB removal time of decoding unit m , the decoding unit is instantaneously decoded, and when decoding unit m is the last decoding unit of access unit n , the following apply:

- Picture n is considered as decoded.
- The final CPB arrival time of access unit n , i.e. $AuFinalArrivalTime[n]$, is set equal to the final CPB arrival time of the last decoding unit in access unit n , i.e. $DuFinalArrivalTime[m]$.
- The nominal CPB removal time of access unit n , i.e. $AuNominalRemovalTime[n]$, is set equal to the nominal CPB removal time of the last decoding unit in access unit n , i.e. $DuNominalRemovalTime[m]$.
- The CPB removal time of access unit n , i.e. $AuCpbRemovalTime[m]$, is set equal to the CPB removal time of the last decoding unit in access unit n , i.e. $DuCpbRemovalTime[m]$.

C.3 Operation of the decoded picture buffer (DPB)

C.3.1 General

The specifications in this clause apply independently to each set of DPB parameters selected as specified in C.1.

The decoded picture buffer contains picture storage buffers. Each of the picture storage buffers may contain a decoded picture that is marked as “used for reference” or is held for future output. The processes specified in C.3.2, C.3.3, C.3.4, and C.3.5 are sequentially applied as specified below.

C.3.2 Removal of pictures from the DPB before decoding of the current picture

The removal of pictures from the DPB before decoding of the current picture (but after parsing the slice header of the first slice of the current picture) happens instantaneously at the CPB removal time of the first decoding unit of access unit n (containing the current picture) and proceeds as follows:

- The decoding process for RPS as specified in 8.3.2 is invoked.
 - When the current picture is an IRAP picture with `NoRaslOutputFlag` equal to 1 that is not picture 0, the following ordered steps are applied:
 1. The variable `NoOutputOfPriorPicsFlag` is derived for the decoder under test as follows:
 - If the current picture is a CRA picture, `NoOutputOfPriorPicsFlag` is set equal to 1 (regardless of the value of `no_output_of_prior_pics_flag`).
 - Otherwise, if the value of `pic_width_in_luma_samples`, `pic_height_in_luma_samples`, `chroma_format_idc`, `separate_colour_plane_flag`, `bit_depth_luma_minus8`, `bit_depth_chroma_minus8`, or `sps_max_dec_pic_buffering_minus1[HighestTid]` derived from the active SPS is different from the value of `pic_width_in_luma_samples`, `pic_height_in_luma_samples`, `chroma_format_idc`, `separate_colour_plane_flag`, `bit_depth_luma_minus8`, `bit_depth_chroma_minus8`, or `sps_max_dec_pic_buffering_minus1[HighestTid]`, respectively, derived from the SPS active for the preceding picture, `NoOutputOfPriorPicsFlag` may (but should not) be set to 1 by the decoder under test, regardless of the value of `no_output_of_prior_pics_flag`.
- NOTE Although setting `NoOutputOfPriorPicsFlag` equal to `no_output_of_prior_pics_flag` is preferred under these conditions, the decoder under test can set `NoOutputOfPriorPicsFlag` to 1 in this case.
- Otherwise, `NoOutputOfPriorPicsFlag` is set equal to `no_output_of_prior_pics_flag`.
 - 2. The value of `NoOutputOfPriorPicsFlag` derived for the decoder under test is applied for the HRD such that when the value of `NoOutputOfPriorPicsFlag` is equal to 1, all picture storage buffers in the DPB are emptied without output of the pictures they contain, and the DPB fullness is set equal to 0.
- When both of the following conditions are true for any pictures k in the DPB, all such pictures k in the DPB are removed from the DPB:
 - picture k is marked as “unused for reference”
 - picture k has `PicOutputFlag` equal to 0 or its DPB output time is less than or equal to the CPB removal time of the first decoding unit (denoted as decoding unit m) of the current picture n , i.e. `DpbOutputTime[k]` is less than or equal to `CpbRemovalTime(m)`
- For each picture that is removed from the DPB, the DPB fullness is decremented by one.

C.3.3 Picture output

The processes specified in this clause happen instantaneously at the CPB removal time of access unit n , $AuCpbRemovalTime[n]$.

When picture n has $PicOutputFlag$ equal to 1, its DPB output time $DpbOutputTime[n]$ is derived as follows, where the variable $firstPicInBufferingPeriodFlag$ is equal to 1 if access unit n is the first access unit of a buffering period and 0 otherwise:

```

if( !SubPicHrdFlag ) {
    DpbOutputTime[ n ] = AuCpbRemovalTime[ n ] + ClockTick * picDpbOutputDelay          (C-15)
    if( firstPicInBufferingPeriodFlag )
        DpbOutputTime[ n ] -= ClockTick * DpbDelayOffset
} else
    DpbOutputTime[ n ] = AuCpbRemovalTime[ n ] + ClockSubTick * picSptDpbOutputDuDelay

```

where $picDpbOutputDelay$ is the value of $pic_dpb_output_delay$ in the picture timing SEI message associated with access unit n , and $picSptDpbOutputDuDelay$ is the value of $pic_spt_dpb_output_du_delay$, when present, in the decoding unit information SEI messages associated with access unit n , or the value of $pic_dpb_output_du_delay$ in the picture timing SEI message associated with access unit n when there is no decoding unit information SEI message associated with access unit n or no decoding unit information SEI message associated with access unit n has $pic_spt_dpb_output_du_delay$ present.

NOTE When the syntax element $pic_spt_dpb_output_du_delay$ is not present in any decoding unit information SEI message associated with access unit n , the value is inferred to be equal to $pic_dpb_output_du_delay$ in the picture timing SEI message associated with access unit n .

The output of the current picture is specified as follows:

- If $PicOutputFlag$ is equal to 1 and $DpbOutputTime[n]$ is equal to $AuCpbRemovalTime[n]$, the current picture is output.
- Otherwise, if $PicOutputFlag$ is equal to 0, the current picture is not output, but will be stored in the DPB as specified in C.3.4.
- Otherwise ($PicOutputFlag$ is equal to 1 and $DpbOutputTime[n]$ is greater than $AuCpbRemovalTime[n]$), the current picture is output later and will be stored in the DPB (as specified in C.3.4) and is output at time $DpbOutputTime[n]$ unless indicated not to be output by the decoding or inference of $no_output_of_prior_pics_flag$ equal to 1 at a time that precedes $DpbOutputTime[n]$.

When output, the picture is cropped, using the conformance cropping window specified in the active SPS for the picture.

When picture n is a picture that is output and is not the last picture of the bitstream that is output, the value of the variable $DpbOutputInterval[n]$ is derived as follows:

$$DpbOutputInterval[n] = DpbOutputTime[nextPicInOutputOrder] - DpbOutputTime[n] \quad (C-16)$$

where $nextPicInOutputOrder$ is the picture that follows picture n in output order and has $PicOutputFlag$ equal to 1.

C.3.4 Current decoded picture marking and storage

The current decoded picture after the invocation of the in-loop filter process as specified in 8.7 is stored in the DPB in an empty picture storage buffer, the DPB fullness is incremented by one. When $TwoVersionsOfCurrDecPicFlag$ is equal to 0 and $pps_curr_pic_ref_enabled_flag$ is equal to 1, this picture is marked as "used for long-term reference". After all the slices of the current picture have been decoded, this picture is marked as "used for short-term reference".

When `TwoVersionsOfCurrDecPicFlag` is equal to 1, the current decoded picture before the invocation of the in-loop filter process as specified in 8.7 is stored in the DPB in an empty picture storage buffer, the DPB fullness is incremented by one, and this picture is marked as “used for long-term reference”.

NOTE Unless more memory than required by the level limit is available for storage of decoded pictures, decoders should start storing decoded parts of the current picture into the DPB when the first slice segment is decoded and continue storing more decoded samples as the decoding process proceeds.

C.3.5 Removal of pictures from the DPB after decoding of the current picture

When `TwoVersionsOfCurrDecPicFlag` is equal to 1, immediately after decoding of the current picture, at the CPB removal time of the last decoding unit of access unit *n* (containing the current picture), the current decoded picture before the invocation of the in-loop filter process as specified in 8.7 is removed from the DPB, and the DPB fullness is decremented by one.

C.4 Bitstream conformance

A bitstream of coded data conforming to this document shall fulfil all requirements specified in this clause.

The bitstream shall be constructed according to the syntax, semantics, and constraints specified in this document outside of this annex.

The first coded picture in a bitstream shall be an IRAP picture, i.e. an IDR picture, a CRA picture or a BLA picture.

The bitstream is tested by the HRD for conformance as specified in C.1.

For each current picture, let the variables `maxPicOrderCnt` and `minPicOrderCnt` be set equal to the maximum and the minimum, respectively, of the `PicOrderCntVal` values of the following pictures:

- The current picture.
- The previous picture in decoding order that has `TemporalId` equal to 0 and that is not a RASL, RADL, or SLNR picture.
- The short-term reference pictures in the RPS of the current picture.
- All pictures *n* that have `PicOutputFlag` equal to 1, `AuCpbRemovalTime[n]` less than `AuCpbRemovalTime[currPic]`, and `DpbOutputTime[n]` greater than or equal to `AuCpbRemovalTime[currPic]`, where `currPic` is the current picture.

All of the following conditions shall be fulfilled for each of the bitstream conformance tests:

1. For each access unit *n*, with *n* greater than 0, associated with a buffering period SEI message, let the variable `deltaTime90k[n]` be specified as follows:

$$\text{deltaTime90k}[n] = 90000 * (\text{AuNominalRemovalTime}[n] - \text{AuFinalArrivalTime}[n - 1]) \quad (\text{C-17})$$

The value of `InitCpbRemovalDelay[SchedSelIdx]` is constrained as follows:

- If `cbr_flag[SchedSelIdx]` is equal to 0, the following condition shall be true:

$$\text{InitCpbRemovalDelay}[\text{SchedSelIdx}] \leq \text{Ceil}(\text{deltaTime90k}[n]) \quad (\text{C-18})$$

- Otherwise (`cbr_flag[SchedSelIdx]` is equal to 1), the following condition shall be true:

$$\text{Floor}(\text{deltaTime90k}[n]) \leq \text{InitCpbRemovalDelay}[\text{SchedSelIdx}] \leq \text{Ceil}(\text{deltaTime90k}[n]) \quad (\text{C-19})$$

ISO/IEC 23008-2:2017(E)

NOTE 1 The exact number of bits in the CPB at the removal time of each picture may depend on which buffering period SEI message is selected to initialize the HRD. Encoders must take this into account to ensure that all specified constraints must be obeyed regardless of which buffering period SEI message is selected to initialize the HRD, as the HRD may be initialized at any one of the buffering period SEI messages.

2. A CPB overflow is specified as the condition in which the total number of bits in the CPB is greater than the CPB size. The CPB shall never overflow.
3. A CPB underflow is specified as the condition in which the nominal CPB removal time of decoding unit m $DuNominalRemovalTime(m)$ is less than the final CPB arrival time of decoding unit m $DuFinalArrivalTime(m)$ for at least one value of m . When $low_delay_hrd_flag[HighestTid]$ is equal to 0, the CPB shall never underflow.
4. When $SubPicHrdFlag$ is equal to 1, $low_delay_hrd_flag[HighestTid]$ is equal to 1, and the nominal removal time of a decoding unit m of access unit n is less than the final CPB arrival time of decoding unit m (i.e. $DuNominalRemovalTime[m] < DuFinalArrivalTime[m]$), the nominal removal time of access unit n shall be less than the final CPB arrival time of access unit n (i.e. $AuNominalRemovalTime[n] < AuFinalArrivalTime[n]$).
5. The nominal removal times of pictures from the CPB (starting from the second picture in decoding order) shall satisfy the constraints on $AuNominalRemovalTime[n]$ and $AuCpbRemovalTime[n]$ expressed in A.4.1 through A.4.2.
6. For each current picture, after invocation of the process for removal of pictures from the DPB as specified in C.3.2, the number of decoded pictures in the DPB, including all pictures n that are marked as “used for reference”, or that have $PicOutputFlag$ equal to 1 and $AuCpbRemovalTime[n]$ less than $AuCpbRemovalTime[currPic]$, where $currPic$ is the current picture, shall be less than or equal to $sps_max_dec_pic_buffering_minus1[HighestTid]$.
7. All reference pictures shall be present in the DPB when needed for prediction. Each picture that has $PicOutputFlag$ equal to 1 shall be present in the DPB at its DPB output time unless it is removed from the DPB before its output time by one of the processes specified in C.3.
8. For each current picture that is not an IRAP picture with $NoRaslOutputFlag$ equal to 1, the value of $maxPicOrderCnt - minPicOrderCnt$ shall be less than $MaxPicOrderCntLsb / 2$.
9. The value of $DpbOutputInterval[n]$ as given by Formula (C-16), which is the difference between the output time of a picture and that of the first picture following it in output order and having $PicOutputFlag$ equal to 1, shall satisfy the constraint expressed in A.4.1 for the profile, tier and level specified in the bitstream using the decoding process specified in Clauses 2 through 10.
10. For each current picture, when $sub_pic_cpb_params_in_pic_timing_sei_flag$ is equal to 1, let $tmpCpbRemovalDelaySum$ be derived as follows:
$$tmpCpbRemovalDelaySum = 0$$
$$\text{for } (i = 0; i < num_decoding_units_minus1; i++) \quad (C-20)$$
$$tmpCpbRemovalDelaySum += du_cpb_removal_delay_increment_minus1[i] + 1$$

The value of $ClockSubTick * tmpCpbRemovalDelaySum$ shall be equal to the difference between the nominal CPB removal time of the current access unit and the nominal CPB removal time of the first decoding unit in the current access unit in decoding order.
11. For any two pictures m and n in the same CVS, when $DpbOutputTime[m]$ is greater than $DpbOutputTime[n]$, the $PicOrderCntVal$ of picture m shall be greater than the $PicOrderCntVal$ of picture n .

NOTE 2 All pictures of an earlier CVS in decoding order that are output are output before any pictures of a later CVS in decoding order. Within any particular CVS, the pictures that are output are output in increasing PicOrderCntVal order.

C.5 Decoder conformance

C.5.1 General

A decoder conforming to this document shall fulfil all requirements specified in this clause.

A decoder claiming conformance to a specific profile, tier and level shall be able to successfully decode all bitstreams that conform to the bitstream conformance requirements specified in C.4, in the manner specified in Annex A, provided that all VPSs, SPSs and PPSs referred to in the VCL NAL units, and appropriate buffering period and picture timing SEI messages are conveyed to the decoder, in a timely manner, either in the bitstream (by non-VCL NAL units), or by external means not specified in this document.

When a bitstream contains syntax elements that have values that are specified as reserved and it is specified that decoders shall ignore values of the syntax elements or NAL units containing the syntax elements having the reserved values, and the bitstream is otherwise conforming to this document, a conforming decoder shall decode the bitstream in the same manner as it would decode a conforming bitstream and shall ignore the syntax elements or the NAL units containing the syntax elements having the reserved values as specified.

There are two types of conformance that can be claimed by a decoder: output timing conformance and output order conformance.

To check conformance of a decoder, test bitstreams conforming to the claimed profile, tier and level, as specified in C.4 are delivered by a hypothetical stream scheduler (HSS) both to the HRD and to the decoder under test (DUT). All cropped decoded pictures output by the HRD shall also be output by the DUT, each cropped decoded picture output by the DUT shall be a picture with PicOutputFlag equal to 1, and, for each such cropped decoded picture output by the DUT, the values of all samples that are output shall be equal to the values of the samples produced by the specified decoding process.

For output timing decoder conformance, the HSS operates as described above, with delivery schedules selected only from the subset of values of SchedSelIdx for which the bit rate and CPB size are restricted as specified in Annex A for the specified profile, tier and level, or with "interpolated" delivery schedules as specified below for which the bit rate and CPB size are restricted as specified in Annex A. The same delivery schedule is used for both the HRD and the DUT.

When the HRD parameters and the buffering period SEI messages are present with cpb_cnt_minus1[HighestTid] greater than 0, the decoder shall be capable of decoding the bitstream as delivered from the HSS operating using an "interpolated" delivery schedule specified as having peak bit rate r , CPB size $c(r)$, and initial CPB removal delay $(f(r) \div r)$ as follows:

$$\alpha = (r - \text{BitRate}[\text{SchedSelIdx} - 1]) \div (\text{BitRate}[\text{SchedSelIdx}] - \text{BitRate}[\text{SchedSelIdx} - 1]), \quad (\text{C-21})$$

$$c(r) = \alpha * \text{CpbSize}[\text{SchedSelIdx}] + (1 - \alpha) * \text{CpbSize}[\text{SchedSelIdx} - 1], \quad (\text{C-22})$$

$$f(r) = \alpha * \text{InitCpbRemovalDelay}[\text{SchedSelIdx}] * \text{BitRate}[\text{SchedSelIdx}] + (1 - \alpha) * \text{InitCpbRemovalDelay}[\text{SchedSelIdx} - 1] * \text{BitRate}[\text{SchedSelIdx} - 1] \quad (\text{C-23})$$

for any SchedSelIdx > 0 and r such that $\text{BitRate}[\text{SchedSelIdx} - 1] \leq r \leq \text{BitRate}[\text{SchedSelIdx}]$ such that r and $c(r)$ are within the limits as specified in Annex A for the maximum bit rate and buffer size for the specified profile, tier and level.

NOTE 1 InitCpbRemovalDelay[SchedSelIdx] can be different from one buffering period to another and have to be re-calculated.

ISO/IEC 23008-2:2017(E)

For output timing decoder conformance, an HRD as described above is used and the timing (relative to the delivery time of the first bit) of picture output is the same for both the HRD and the DUT up to a fixed delay.

For output order decoder conformance, the following apply

- The HSS delivers the bitstream `BitstreamToDecode` to the DUT "by demand" from the DUT, meaning that the HSS delivers bits (in decoding order) only when the DUT requires more bits to proceed with its processing.

NOTE 2 This means that for this test, the coded picture buffer of the DUT could be as small as the size of the largest decoding unit.

- A modified HRD as described below is used, and the HSS delivers the bitstream to the HRD by one of the schedules specified in the bitstream `BitstreamToDecode` such that the bit rate and CPB size are restricted as specified in Annex A. The order of pictures output shall be the same for both the HRD and the DUT.
- The HRD CPB size is given by `CpbSize[SchedSelIdx]` as specified in E.3.3, where `SchedSelIdx` and the HRD parameters are selected as specified in C.1. The DPB size is given by `sps_max_dec_pic_buffering_minus1[HighestTid] + 1`. Removal time from the CPB for the HRD is the final bit arrival time and decoding is immediate. The operation of the DPB of this HRD is as described in C.5.2 through C.5.2.3.

C.5.2 Operation of the output order DPB

C.5.2.1 General

The decoded picture buffer contains picture storage buffers. Each of the picture storage buffers contains a decoded picture that is marked as "used for reference" or is held for future output. The process for output and removal of pictures from the DPB before decoding of the current picture as specified in C.5.2.2 is invoked, the invocation of the process for current decoded picture marking and storage as specified in C.3.4, further followed by the invocation of the process for removal of pictures from the DPB after decoding of the current picture as specified in C.3.5, and finally followed by the invocation of the process for additional bumping as specified in C.5.2.3. The "bumping" process is specified in C.5.2.4 and is invoked as specified in C.5.2.2 and C.5.2.3.

C.5.2.2 Output and removal of pictures from the DPB

The output and removal of pictures from the DPB before the decoding of the current picture (but after parsing the slice header of the first slice of the current picture) happens instantaneously when the first decoding unit of the access unit containing the current picture is removed from the CPB and proceeds as follows:

- The decoding process for RPS as specified in 8.3.2 is invoked.
- If the current picture is an IRAP picture with `NoRaslOutputFlag` equal to 1 that is not picture 0, the following ordered steps are applied:
 1. The variable `NoOutputOfPriorPicsFlag` is derived for the decoder under test as follows:
 - If the current picture is a CRA picture, `NoOutputOfPriorPicsFlag` is set equal to 1 (regardless of the value of `no_output_of_prior_pics_flag`).
 - Otherwise, if the value of `pic_width_in_luma_samples`, `pic_height_in_luma_samples`, `chroma_format_idc`, `separate_colour_plane_flag`, `bit_depth_luma_minus8`, `bit_depth_chroma_minus8`, or `sps_max_dec_pic_buffering_minus1[HighestTid]` derived from the active SPS is different from the value of `pic_width_in_luma_samples`,

pic_height_in_luma_samples, chroma_format_idc, separate_colour_plane_flag, bit_depth_luma_minus8, bit_depth_chroma_minus8, or sps_max_dec_pic_buffering_minus1[HighestTid], respectively, derived from the SPS active for the preceding picture, NoOutputOfPriorPicsFlag may (but should not) be set to 1 by the decoder under test, regardless of the value of no_output_of_prior_pics_flag.

NOTE Although setting NoOutputOfPriorPicsFlag equal to no_output_of_prior_pics_flag is preferred under these conditions, the decoder under test is allowed to set NoOutputOfPriorPicsFlag to 1 in this case.

- Otherwise, NoOutputOfPriorPicsFlag is set equal to no_output_of_prior_pics_flag.
- 2. The value of NoOutputOfPriorPicsFlag derived for the decoder under test is applied for the HRD as follows:
 - If NoOutputOfPriorPicsFlag is equal to 1, all picture storage buffers in the DPB are emptied without output of the pictures they contain, and the DPB fullness is set equal to 0.
 - Otherwise (NoOutputOfPriorPicsFlag is equal to 0), all picture storage buffers containing a picture that is marked as "not needed for output" and "unused for reference" are emptied (without output), and all non-empty picture storage buffers in the DPB are emptied by repeatedly invoking the "bumping" process specified in C.5.2.4, and the DPB fullness is set equal to 0.
- Otherwise (the current picture is not an IRAP picture with NoRaslOutputFlag equal to 1), all picture storage buffers containing a picture which are marked as "not needed for output" and "unused for reference" are emptied (without output). For each picture storage buffer that is emptied, the DPB fullness is decremented by one. When one or more of the following conditions are true, the "bumping" process specified in C.5.2.4 is invoked repeatedly while further decrementing the DPB fullness by one for each additional picture storage buffer that is emptied, until none of the following conditions are true:
 - The number of pictures in the DPB that are marked as "needed for output" is greater than sps_max_num_reorder_pics[HighestTid].
 - sps_max_latency_increase_plus1[HighestTid] is not equal to 0 and there is at least one picture in the DPB that is marked as "needed for output" for which the associated variable PicLatencyCount is greater than or equal to SpsMaxLatencyPictures[HighestTid].
 - The number of pictures in the DPB is greater than or equal to sps_max_dec_pic_buffering_minus1[HighestTid] + 1 – TwoVersionsOfCurrDecPicFlag.

C.5.2.3 Additional bumping

The processes specified in this subclause happen instantaneously when the last decoding unit of access unit n containing the current picture is removed from the CPB.

When the current picture has PicOutputFlag equal to 1, for each picture in the DPB that is marked as "needed for output" and follows the current picture in output order, the associated variable PicLatencyCount is set equal to PicLatencyCount + 1.

ISO/IEC 23008-2:2017(E)

The following apply:

- If the current decoded picture has PicOutputFlag equal to 1, it is marked as “needed for output” and its associated variable PicLatencyCount is set equal to 0.
- Otherwise (the current decoded picture has PicOutputFlag equal to 0), it is marked as “not needed for output”.

When one or more of the following conditions are true, the “bumping” process specified in C.5.2.4 is invoked repeatedly until none of the following conditions are true:

- The number of pictures in the DPB that are marked as “needed for output” is greater than $sps_max_num_reorder_pics[HighestTid]$.
- $sps_max_latency_increase_plus1[HighestTid]$ is not equal to 0 and there is at least one picture in the DPB that is marked as “needed for output” for which the associated variable PicLatencyCount that is greater than or equal to $SpsMaxLatencyPictures[HighestTid]$.

C.5.2.4 “Bumping” process

The “bumping” process consists of the following ordered steps:

1. The picture that is first for output is selected as the one having the smallest value of PicOrderCntVal of all pictures in the DPB marked as “needed for output”.
2. The picture is cropped, using the conformance cropping window specified in the active SPS for the picture, the cropped picture is output, and the picture is marked as “not needed for output”.
3. When the picture storage buffer that included the picture that was cropped and output contains a picture marked as “unused for reference”, the picture storage buffer is emptied.

NOTE For any two pictures picA and picB that belong to the same CVS and are output by the “bumping process”, when picA is output earlier than picB, the value of PicOrderCntVal of picA is less than the value of PicOrderCntVal of picB.

Annex D (normative)

Supplemental enhancement information

D.1 General

This annex specifies syntax and semantics for SEI message payloads.

SEI messages assist in processes related to decoding, display or other purposes. However, SEI messages are not required for constructing the luma or chroma samples by the decoding process. Conforming decoders are not required to process this information for output order conformance to this document (see Annex C and F.13 for the specification of conformance). Some SEI message information is required to check bitstream conformance and for output timing decoder conformance.

In C.5.2 and in F.13 including its subclauses, specification for presence of SEI messages are also satisfied when those messages (or some subset of them) are conveyed to decoders (or to the HRD) by other means not specified in this document. When present in the bitstream, SEI messages shall obey the syntax and semantics specified in 7.3.5 and this annex. When the content of an SEI message is conveyed for the application by some means other than presence within the bitstream, the representation of the content of the SEI message is not required to use the same syntax specified in this annex. For the purpose of counting bits, only the appropriate bits that are actually present in the bitstream are counted.

D.2 SEI payload syntax

D.2.1 General SEI message syntax

sei_payload(payloadType, payloadSize) {	Descriptor
if(nal_unit_type == PREFIX_SEI_NUT)	
if(payloadType == 0)	
buffering_period(payloadSize)	
else if(payloadType == 1)	
pic_timing(payloadSize)	
else if(payloadType == 2)	
pan_scan_rect(payloadSize)	
else if(payloadType == 3)	
filler_payload(payloadSize)	
else if(payloadType == 4)	
user_data_registered_itu_t_t35(payloadSize)	
else if(payloadType == 5)	
user_data_unregistered(payloadSize)	
else if(payloadType == 6)	
recovery_point(payloadSize)	
else if(payloadType == 9)	
scene_info(payloadSize)	
else if(payloadType == 15)	

ISO/IEC 23008-2:2017(E)

picture_snapshot(payloadSize)	
else if(payloadType = = 16)	
progressive_refinement_segment_start(payloadSize)	
else if(payloadType = = 17)	
progressive_refinement_segment_end(payloadSize)	
else if(payloadType = = 19)	
film_grain_characteristics(payloadSize)	
else if(payloadType = = 22)	
post_filter_hint(payloadSize)	
else if(payloadType = = 23)	
tone_mapping_info(payloadSize)	
else if(payloadType = = 45)	
frame_packing_arrangement(payloadSize)	
else if(payloadType = = 47)	
display_orientation(payloadSize)	
else if(payloadType = = 56)	
green_metadata(payloadsize) /* specified in ISO/IEC 23001-11 */	
else if(payloadType = = 128)	
structure_of_pictures_info(payloadSize)	
else if(payloadType = = 129)	
active_parameter_sets(payloadSize)	
else if(payloadType = = 130)	
decoding_unit_info(payloadSize)	
else if(payloadType = = 131)	
temporal_sub_layer_zero_index(payloadSize)	
else if(payloadType = = 133)	
scalable_nesting(payloadSize)	
else if(payloadType = = 134)	
region_refresh_info(payloadSize)	
else if(payloadType = = 135)	
no_display(payloadSize)	
else if(payloadType = = 136)	
time_code(payloadSize)	
else if(payloadType = = 137)	
mastering_display_colour_volume(payloadSize)	
else if(payloadType = = 138)	
segmented_rect_frame_packing_arrangement(payloadSize)	
else if(payloadType = = 139)	
temporal_motion_constrained_tile_sets(payloadSize)	
else if(payloadType = = 140)	
chroma_resampling_filter_hint(payloadSize)	

else if(payloadType == 141)	
knee_function_info(payloadSize)	
else if(payloadType == 142)	
colour_remapping_info(payloadSize)	
else if(payloadType == 143)	
deinterlaced_field_identification(payloadSize)	
else if(payloadType == 144)	
content_light_level_info(payloadSize)	
else if(payloadType == 145)	
dependent_rap_indication(payloadSize)	
else if(payloadType == 146)	
coded_region_completion(payloadSize)	
else if(payloadType == 147)	
alternative_transfer_characteristics(payloadSize)	
else if(payloadType == 148)	
ambient_viewing_environment(payloadSize)	
else if(payloadType == 160)	
layers_not_present(payloadSize) /* specified in Annex F */	
else if(payloadType == 161)	
inter_layer_constrained_tile_sets(payloadSize) /* specified in Annex F */	
else if(payloadType == 162)	
bsp_nesting(payloadSize) /* specified in Annex F */	
else if(payloadType == 163)	
bsp_initial_arrival_time(payloadSize) /* specified in Annex F */	
else if(payloadType == 164)	
sub_bitstream_property(payloadSize) /* specified in Annex F */	
else if(payloadType == 165)	
alpha_channel_info(payloadSize) /* specified in Annex F */	
else if(payloadType == 166)	
overlay_info(payloadSize) /* specified in Annex F */	
else if(payloadType == 167)	
temporal_mv_prediction_constraints(payloadSize) /* specified in Annex F */	
else if(payloadType == 168)	
frame_field_info(payloadSize) /* specified in Annex F */	
else if(payloadType == 176)	
three_dimensional_reference_displays_info(payloadSize) /* specified in Annex G */	
else if(payloadType == 177)	
depth_representation_info(payloadSize) /* specified in Annex G */	
else if(payloadType == 178)	
multiview_scene_info(payloadSize) /* specified in Annex G */	
else if(payloadType == 179)	

ISO/IEC 23008-2:2017(E)

multiview_acquisition_info(payloadSize) /* specified in Annex G */	
else if(payloadType == 180)	
multiview_view_position(payloadSize) /* specified in Annex G */	
else if(payloadType == 181)	
alternative_depth_info(payloadSize) /* specified in Annex I */	
else	
reserved_sei_message(payloadSize)	
else /* nal_unit_type == SUFFIX_SEI_NUT */	
if(payloadType == 3)	
filler_payload(payloadSize)	
else if(payloadType == 4)	
user_data_registered_itu_t_t35(payloadSize)	
else if(payloadType == 5)	
user_data_unregistered(payloadSize)	
else if(payloadType == 17)	
progressive_refinement_segment_end(payloadSize)	
else if(payloadType == 22)	
post_filter_hint(payloadSize)	
else if(payloadType == 132)	
decoded_picture_hash(payloadSize)	
else if(payloadType == 146)	
coded_region_completion(payloadSize)	
else	
reserved_sei_message(payloadSize)	
if(more_data_in_payload()) {	
if(payload_extension_present())	
reserved_payload_extension_data	u(v)
payload_bit_equal_to_one /* equal to 1 */	f(1)
while(!byte_aligned())	
payload_bit_equal_to_zero /* equal to 0 */	f(1)
}	
}	

D.2.2 Buffering period SEI message syntax

	Descriptor
buffering_period(payloadSize) {	
bp_seq_parameter_set_id	ue(v)
if(!sub_pic_hrd_params_present_flag)	
irap_cpb_params_present_flag	u(1)
if(irap_cpb_params_present_flag) {	
cpb_delay_offset	u(v)
dpb_delay_offset	u(v)

}	
concatenation_flag	u(1)
au_cpb_removal_delay_delta_minus1	u(v)
if(NalHrdBpPresentFlag) {	
for(i = 0; i <= CpbCnt; i++) {	
nal_initial_cpb_removal_delay [i]	u(v)
nal_initial_cpb_removal_offset [i]	u(v)
if(sub_pic_hrd_params_present_flag irap_cpb_params_present_flag) {	
nal_initial_alt_cpb_removal_delay [i]	u(v)
nal_initial_alt_cpb_removal_offset [i]	u(v)
}	
}	
}	
}	
if(VclHrdBpPresentFlag) {	
for(i = 0; i <= CpbCnt; i++) {	
vcl_initial_cpb_removal_delay [i]	u(v)
vcl_initial_cpb_removal_offset [i]	u(v)
if(sub_pic_hrd_params_present_flag irap_cpb_params_present_flag) {	
vcl_initial_alt_cpb_removal_delay [i]	u(v)
vcl_initial_alt_cpb_removal_offset [i]	u(v)
}	
}	
}	
if(payload_extension_present())	
use_alt_cpb_params_flag	u(1)
}	

D.2.3 Picture timing SEI message syntax

	Descriptor
pic_timing(payloadSize) {	
if(frame_field_info_present_flag) {	
pic_struct	u(4)
source_scan_type	u(2)
duplicate_flag	u(1)
}	
if(CpbDpbDelaysPresentFlag) {	
au_cpb_removal_delay_minus1	u(v)
pic_dpb_output_delay	u(v)
if(sub_pic_hrd_params_present_flag)	

pic_dpb_output_du_delay	u(v)
if(sub_pic_hrd_params_present_flag && sub_pic_cpb_params_in_pic_timing_sei_flag) {	
num_decoding_units_minus1	ue(v)
du_common_cpb_removal_delay_flag	u(1)
if(du_common_cpb_removal_delay_flag)	
du_common_cpb_removal_delay_increment_minus1	u(v)
for(i = 0; i <= num_decoding_units_minus1; i++) {	
num_nalus_in_du_minus1[i]	ue(v)
if(!du_common_cpb_removal_delay_flag && i < num_decoding_units_minus1)	
du_cpb_removal_delay_increment_minus1[i]	u(v)
}	
}	
}	
}	

D.2.4 Pan-scan rectangle SEI message syntax

	Descriptor
pan_scan_rect(payloadSize) {	
pan_scan_rect_id	ue(v)
pan_scan_rect_cancel_flag	u(1)
if(!pan_scan_rect_cancel_flag) {	
pan_scan_cnt_minus1	ue(v)
for(i = 0; i <= pan_scan_cnt_minus1; i++) {	
pan_scan_rect_left_offset[i]	se(v)
pan_scan_rect_right_offset[i]	se(v)
pan_scan_rect_top_offset[i]	se(v)
pan_scan_rect_bottom_offset[i]	se(v)
}	
pan_scan_rect_persistence_flag	u(1)
}	
}	

D.2.5 Filler payload SEI message syntax

	Descriptor
filler_payload(payloadSize) {	
for(k = 0; k < payloadSize; k++)	
ff_byte /* equal to 0xFF */	f(8)
}	

D.2.6 User data registered by Rec. ITU-T T.35 SEI message syntax

	Descriptor
user_data_registered_itu_t_t35(payloadSize) {	
itu_t_t35_country_code	b(8)
if(itu_t_t35_country_code != 0xFF)	
i = 1	
else {	
itu_t_t35_country_code_extension_byte	b(8)
i = 2	
}	
do {	
itu_t_t35_payload_byte	b(8)
i++	
} while(i < payloadSize)	
}	

D.2.7 User data unregistered SEI message syntax

	Descriptor
user_data_unregistered(payloadSize) {	
uuid_iso_iec_11578	u(128)
for(i = 16; i < payloadSize; i++)	
user_data_payload_byte	b(8)
}	

D.2.8 Recovery point SEI message syntax

	Descriptor
recovery_point(payloadSize) {	
recovery_poc_cnt	se(v)
exact_match_flag	u(1)
broken_link_flag	u(1)
}	

D.2.9 Scene information SEI message syntax

	Descriptor
scene_info(payloadSize) {	
scene_info_present_flag	u(1)
if(scene_info_present_flag) {	
prev_scene_id_valid_flag	u(1)
scene_id	ue(v)
scene_transition_type	ue(v)
if(scene_transition_type > 3)	
second_scene_id	ue(v)
}	
}	

D.2.10 Picture snapshot SEI message syntax

	Descriptor
picture_snapshot(payloadSize) {	
snapshot_id	ue(v)
}	

D.2.11 Progressive refinement segment start SEI message syntax

	Descriptor
progressive_refinement_segment_start(payloadSize) {	
progressive_refinement_id	ue(v)
pic_order_cnt_delta	ue(v)
}	

D.2.12 Progressive refinement segment end SEI message syntax

	Descriptor
progressive_refinement_segment_end(payloadSize) {	
progressive_refinement_id	ue(v)
}	

D.2.13 Film grain characteristics SEI message syntax

	Descriptor
film_grain_characteristics(payloadSize) {	
film_grain_characteristics_cancel_flag	u(1)
if(!film_grain_characteristics_cancel_flag) {	
film_grain_model_id	u(2)
separate_colour_description_present_flag	u(1)
if(separate_colour_description_present_flag) {	
film_grain_bit_depth_luma_minus8	u(3)
film_grain_bit_depth_chroma_minus8	u(3)
film_grain_full_range_flag	u(1)
film_grain_colour primaries	u(8)
film_grain_transfer characteristics	u(8)
film_grain_matrix_coeffs	u(8)
}	
blending_mode_id	u(2)
log2_scale_factor	u(4)
for(c = 0; c < 3; c++)	
comp_model_present_flag[c]	u(1)
for(c = 0; c < 3; c++)	
if(comp_model_present_flag[c]) {	
num_intensity_intervals_minus1[c]	u(8)
num_model_values_minus1[c]	u(3)
for(i = 0; i <= num_intensity_intervals_minus1[c]; i++) {	
intensity_interval_lower_bound[c][i]	u(8)
}	

intensity_interval_upper_bound [c][i]	u(8)
for(j = 0; j <= num_model_values_minus1[c]; j++)	
comp_model_value [c][i][j]	se(v)
}	
}	
film_grain_characteristics_persistence_flag	u(1)
}	
}	

D.2.14 Post-filter hint SEI message syntax

post_filter_hint(payloadSize) {	Descriptor
filter_hint_size_y	ue(v)
filter_hint_size_x	ue(v)
filter_hint_type	u(2)
for(cldx = 0; cldx < (chroma_format_idc == 0 ? 1 : 3); cldx++)	
for(cy = 0; cy < filter_hint_size_y; cy++)	
for(cx = 0; cx < filter_hint_size_x; cx++)	
filter_hint_value [cldx][cy][cx]	se(v)
}	

D.2.15 Tone mapping information SEI message syntax

tone_mapping_info(payloadSize) {	Descriptor
tone_map_id	ue(v)
tone_map_cancel_flag	u(1)
if(!tone_map_cancel_flag) {	
tone_map_persistence_flag	u(1)
coded_data_bit_depth	u(8)
target_bit_depth	u(8)
tone_map_model_id	ue(v)
if(tone_map_model_id == 0) {	
min_value	u(32)
max_value	u(32)
} else if(tone_map_model_id == 1) {	
sigmoid_midpoint	u(32)
sigmoid_width	u(32)
} else if(tone_map_model_id == 2)	
for(i = 0; i < (1 << target_bit_depth); i++)	
start_of_coded_interval [i]	u(v)
} else if(tone_map_model_id == 3) {	
num_pivots	u(16)

for(i = 0; i < num_pivots; i++) {	
coded_pivot_value [i]	u(v)
target_pivot_value [i]	u(v)
}	
} else if(tone_map_model_id == 4) {	
camera_iso_speed_idc	u(8)
if(camera_iso_speed_idc == EXTENDED_ISO)	
camera_iso_speed_value	u(32)
exposure_index_idc	u(8)
if(exposure_index_idc == EXTENDED_ISO)	
exposure_index_value	u(32)
exposure_compensation_value_sign_flag	u(1)
exposure_compensation_value_numerator	u(16)
exposure_compensation_value_denom_idc	u(16)
ref_screen_luminance_white	u(32)
extended_range_white_level	u(32)
nominal_black_level_code_value	u(16)
nominal_white_level_code_value	u(16)
extended_white_level_code_value	u(16)
}	
}	
}	

D.2.16 Frame packing arrangement SEI message syntax

	Descriptor
frame_packing_arrangement(payloadSize) {	
frame_packing_arrangement_id	ue(v)
frame_packing_arrangement_cancel_flag	u(1)
if(!frame_packing_arrangement_cancel_flag) {	
frame_packing_arrangement_type	u(7)
quincunx_sampling_flag	u(1)
content_interpretation_type	u(6)
spatial_flipping_flag	u(1)
frame0_flipped_flag	u(1)
field_views_flag	u(1)
current_frame_is_frame0_flag	u(1)
frame0_self_contained_flag	u(1)
frame1_self_contained_flag	u(1)
if(!quincunx_sampling_flag && frame_packing_arrangement_type != 5) {	
frame0_grid_position_x	u(4)

frame0_grid_position_y	u(4)
frame1_grid_position_x	u(4)
frame1_grid_position_y	u(4)
}	
frame_packing_arrangement_reserved_byte	u(8)
frame_packing_arrangement_persistence_flag	u(1)
}	
upsampled_aspect_ratio_flag	u(1)
}	

D.2.17 Display orientation SEI message syntax

	Descriptor
display_orientation(payloadSize) {	
display_orientation_cancel_flag	u(1)
if(!display_orientation_cancel_flag) {	
hor_flip	u(1)
ver_flip	u(1)
anticlockwise_rotation	u(16)
display_orientation_persistence_flag	u(1)
}	
}	

D.2.18 Green metadata SEI message syntax

The syntax for green metadata SEI message is specified in ISO/IEC 23001-11 (Green metadata). Green metadata facilitates reduced power consumption in decoders, encoders, displays and in media selection.

D.2.19 Structure of pictures information SEI message syntax

	Descriptor
structure_of_pictures_info(payloadSize) {	
sop_seq_parameter_set_id	ue(v)
num_entries_in_sop_minus1	ue(v)
for(i = 0; i <= num_entries_in_sop_minus1; i++) {	
sop_vcl_nut[i]	u(6)
sop_temporal_id[i]	u(3)
if(sop_vcl_nut[i] != IDR_W_RADL && sop_vcl_nut[i] != IDR_N_LP)	
sop_short_term_rps_idx[i]	ue(v)
if(i > 0)	
sop_poc_delta[i]	se(v)
}	
}	

D.2.20 Decoded picture hash SEI message syntax

	Descriptor
decoded_picture_hash(payloadSize) {	
hash_type	u(8)
for(cIdx = 0; cIdx < (chroma_format_idc == 0 ? 1 : 3); cIdx++)	
if(hash_type == 0)	
for(i = 0; i < 16; i++)	
picture_md5[cIdx][i]	b(8)
else if(hash_type == 1)	
picture_crc[cIdx]	u(16)
else if(hash_type == 2)	
picture_checksum[cIdx]	u(32)
}	

D.2.21 Active parameter sets SEI message syntax

	Descriptor
active_parameter_sets(payloadSize) {	
active_video_parameter_set_id	u(4)
self_contained_cvs_flag	u(1)
no_parameter_set_update_flag	u(1)
num_sps_ids_minus1	ue(v)
for(i = 0; i <= num_sps_ids_minus1; i++)	
active_seq_parameter_set_id[i]	ue(v)
for(i = vps_base_layer_internal_flag; i <= MaxLayersMinus1; i++)	
layer_sps_idx[i]	ue(v)
}	

D.2.22 Decoding unit information SEI message syntax

	Descriptor
decoding_unit_info(payloadSize) {	
decoding_unit_idx	ue(v)
if(!sub_pic_cpb_params_in_pic_timing_sei_flag)	
du_spt_cpb_removal_delay_increment	u(v)
dpb_output_du_delay_present_flag	u(1)
if(dpb_output_du_delay_present_flag)	
pic_spt_dpb_output_du_delay	u(v)
}	

D.2.23 Temporal sub-layer zero index SEI message syntax

	Descriptor
temporal_sub_layer_zero_index(payloadSize) {	
temporal_sub_layer_zero_idx	u(8)
irap_pic_id	u(8)
}	

D.2.24 Scalable nesting SEI message syntax

	Descriptor
scalable_nesting(payloadSize) {	
bitstream_subset_flag	u(1)
nesting_op_flag	u(1)
if(nesting_op_flag) {	
default_op_flag	u(1)
nesting_num_ops_minus1	ue(v)
for(i = default_op_flag; i <= nesting_num_ops_minus1; i++) {	
nesting_max_temporal_id_plus1[i]	u(3)
nesting_op_idx[i]	ue(v)
}	
} else {	
all_layers_flag	u(1)
if(!all_layers_flag) {	
nesting_no_op_max_temporal_id_plus1	u(3)
nesting_num_layers_minus1	ue(v)
for(i = 0; i <= nesting_num_layers_minus1; i++)	
nesting_layer_id[i]	u(6)
}	
}	
while(!byte_aligned())	
nesting_zero_bit /* equal to 0 */	u(1)
do	
sei_message()	
while(more_rbsp_data())	
}	

D.2.25 Region refresh information SEI message syntax

	Descriptor
region_refresh_info(payloadSize) {	
refreshed_region_flag	u(1)
}	

D.2.26 No display SEI message syntax

	Descriptor
no_display(payloadSize) {	
}	

ISO/IEC 23008-2:2017(E)

D.2.27 Time code SEI message syntax

	Descriptor
time_code(payloadSize) {	
num_clock_ts	u(2)
for(i = 0; i < num_clock_ts; i++) {	
clock_timestamp_flag[i]	u(1)
if(clock_timestamp_flag[i]) {	
units_field_based_flag[i]	u(1)
counting_type[i]	u(5)
full_timestamp_flag[i]	u(1)
discontinuity_flag[i]	u(1)
cnt_dropped_flag[i]	u(1)
n_frames[i]	u(9)
if(full_timestamp_flag[i]) {	
seconds_value[i] /* 0.59 */	u(6)
minutes_value[i] /* 0.59 */	u(6)
hours_value[i] /* 0.23 */	u(5)
} else {	
seconds_flag[i]	u(1)
if(seconds_flag[i]) {	
seconds_value[i] /* 0.59 */	u(6)
minutes_flag[i]	u(1)
if(minutes_flag[i]) {	
minutes_value[i] /* 0.59 */	u(6)
hours_flag[i]	u(1)
if(hours_flag[i])	
hours_value[i] /* 0.23 */	u(5)
}	
}	
}	
time_offset_length[i]	u(5)
if(time_offset_length[i] > 0)	
time_offset_value[i]	i(v)
}	
}	
}	

D.2.28 Mastering display colour volume SEI message syntax

	Descriptor
mastering_display_colour_volume(payloadSize) {	
for(c = 0; c < 3; c++) {	
display primaries_x [c]	u(16)
display primaries_y [c]	u(16)
}	
white_point_x	u(16)
white_point_y	u(16)
max_display_mastering_luminance	u(32)
min_display_mastering_luminance	u(32)
}	

D.2.29 Segmented rectangular frame packing arrangement SEI message syntax

	Descriptor
segmented_rect_frame_packing_arrangement(payloadSize) {	
segmented_rect_frame_packing_arrangement_cancel_flag	u(1)
if(!segmented_rect_frame_packing_arrangement_cancel_flag) {	
segmented_rect_content_interpretation_type	u(2)
segmented_rect_frame_packing_arrangement_persistence_flag	u(1)
}	
}	

D.2.30 Temporal motion-constrained tile sets SEI message syntax

	Descriptor
temporal_motion_constrained_tile_sets(payloadSize) {	
mc_all_tiles_exact_sample_value_match_flag	u(1)
each_tile_one_tile_set_flag	u(1)
if(!each_tile_one_tile_set_flag) {	
limited_tile_set_display_flag	u(1)
num_sets_in_message_minus1	ue(v)
for(i = 0; i <= num_sets_in_message_minus1; i++) {	
mcts_id [i]	ue(v)
if(limited_tile_set_display_flag)	
display_tile_set_flag [i]	u(1)
num_tile_rects_in_set_minus1 [i]	ue(v)
for(j = 0; j <= num_tile_rects_in_set_minus1[i]; j++) {	
top_left_tile_index [i][j]	ue(v)
bottom_right_tile_index [i][j]	ue(v)
}	
}	
if(!mc_all_tiles_exact_sample_value_match_flag)	
mc_exact_sample_value_match_flag [i]	u(1)
mcts_tier_level_idc_present_flag [i]	u(1)

if(mcts_tier_level_idc_present_flag[i]) {	
mcts_tier_flag [i]	u(1)
mcts_level_idc [i]	u(8)
}	
}	
} else {	
max_mcs_tier_level_idc_present_flag	u(1)
if(mcts_max_tier_level_idc_present_flag) {	
mcts_max_tier_flag	u(1)
mcts_max_level_idc	u(8)
}	
}	
}	

D.2.31 Chroma resampling filter hint SEI message syntax

	Descriptor
chroma_resampling_filter_hint(payloadSize) {	
ver_chroma_filter_idc	u(8)
hor_chroma_filter_idc	u(8)
ver_filtering_field_processing_flag	u(1)
if(ver_chroma_filter_idc == 1 hor_chroma_filter_idc == 1) {	
target_format_idc	ue(v)
if(ver_chroma_filter_idc == 1) {	
num_vertical_filters	ue(v)
for(i = 0; i < num_vertical_filters; i++) {	
ver_tap_length_minus1 [i]	ue(v)
for(j = 0; j <= ver_tap_length_minus1[i]; j++)	
ver_filter_coeff [i][j]	se(v)
}	
}	
if(hor_chroma_filter_idc == 1) {	
num_horizontal_filters	ue(v)
for(i = 0; i < num_horizontal_filters; i++) {	
hor_tap_length_minus1 [i]	ue(v)
for(j = 0; j <= hor_tap_length_minus1[i]; j++)	
hor_filter_coeff [i][j]	se(v)
}	
}	
}	

}	
---	--

D.2.32 Knee function information SEI message syntax

	Descriptor
knee_function_info(payloadSize) {	
knee_function_id	ue(v)
knee_function_cancel_flag	u(1)
if(!knee_function_cancel_flag) {	
knee_function_persistence_flag	u(1)
input_d_range	u(32)
input_disp_luminance	u(32)
output_d_range	u(32)
output_disp_luminance	u(32)
num_knee_points_minus1	ue(v)
for(i = 0; i <= num_knee_points_minus1; i++) {	
input_knee_point[i]	u(10)
output_knee_point[i]	u(10)
}	
}	
}	

D.2.33 Colour remapping information SEI message syntax

	Descriptor
colour_remapping_info(payloadSize) {	
colour_remap_id	ue(v)
colour_remap_cancel_flag	u(1)
if(!colour_remap_cancel_flag) {	
colour_remap_persistence_flag	u(1)
colour_remap_video_signal_info_present_flag	u(1)
if(colour_remap_video_signal_info_present_flag) {	
colour_remap_full_range_flag	u(1)
colour_remap_primaries	u(8)
colour_remap_transfer_function	u(8)
colour_remap_matrix_coefficients	u(8)
}	
colour_remap_input_bit_depth	u(8)
colour_remap_output_bit_depth	u(8)
for(c = 0; c < 3; c++) {	
pre_lut_num_val_minus1[c]	u(8)
if(pre_lut_num_val_minus1[c] > 0)	
for(i = 0; i <= pre_lut_num_val_minus1[c]; i++) {	
pre_lut_coded_value[c][i]	u(v)
}	
}	

pre_lut_target_value [c][i]	u(v)
}	
}	
colour_remap_matrix_present_flag	u(1)
if(colour_remap_matrix_present_flag) {	
log2_matrix_denom	u(4)
for(c = 0; c < 3; c++)	
for(i = 0; i < 3; i++)	
colour_remap_coeffs [c][i]	se(v)
}	
for(c = 0; c < 3; c++) {	
post_lut_num_val_minus1 [c]	u(8)
if(post_lut_num_val_minus1[c] > 0)	
for(i = 0; i <= post_lut_num_val_minus1[c]; i++) {	
post_lut_coded_value [c][i]	u(v)
post_lut_target_value [c][i]	u(v)
}	
}	
}	
}	

D.2.34 Deinterlaced field identification SEI message syntax

deinterlaced_field_indentification(payloadSize) {	Descriptor
deinterlaced_picture_source_parity_flag	u(1)
}	

D.2.35 Content light level information SEI message syntax

content_light_level_info(payloadSize) {	Descriptor
max_content_light_level	u(16)
max_pic_average_light_level	u(16)
}	

D.2.36 Dependent random access point indication SEI message syntax

dependent_rap_indication(payloadSize) {	Descriptor
}	

D.2.37 Coded region completion SEI message syntax

	Descriptor
coded_region_completion(payloadSize) {	
next_segment_address	ue(v)
if(next_segment_address > 0)	
independent_slice_segment_flag	u(1)
}	

D.2.38 Alternative transfer characteristics information SEI message syntax

	Descriptor
alternative_transfer_characteristics (payloadSize) {	
preferred_transfer_characteristics	u(8)
}	

D.2.39 Ambient viewing environment SEI message syntax

	Descriptor
ambient_viewing_environment(payloadSize) {	
ambient_illuminance	u(32)
ambient_light_x	u(16)
ambient_light_y	u(16)
}	

D.2.40 Reserved SEI message syntax

	Descriptor
reserved_sei_message(payloadSize) {	
for(i = 0; i < payloadSize; i++)	
reserved_sei_message_payload_byte	b(8)
}	

D.3 SEI payload semantics**D.3.1 General SEI payload semantics**

reserved_payload_extension_data shall not be present in bitstreams conforming to this version of this document. However, decoders conforming to this version of this document shall ignore the presence and value of **reserved_payload_extension_data**. When present, the length, in bits, of **reserved_payload_extension_data** is equal to $8 * \text{payloadSize} - \text{nEarlierBits} - \text{nPayloadZeroBits} - 1$, where **nEarlierBits** is the number of bits in the **sei_payload()** syntax structure that precede the **reserved_payload_extension_data** syntax element, and **nPayloadZeroBits** is the number of **payload_bit_equal_to_zero** syntax elements at the end of the **sei_payload()** syntax structure.

payload_bit_equal_to_one shall be equal to 1.

payload_bit_equal_to_zero shall be equal to 0.

NOTE 1 SEI messages with the same value of **payloadType** are conceptually the same SEI message regardless of whether they are contained in prefix or suffix SEI NAL units.

NOTE 2 For SEI messages with **payloadType** in the range of 0 to 47, inclusive, that are specified in this document, the **payloadType** values are aligned with similar SEI messages specified in Rec. ITU-T H.264 | ISO/IEC 14496-10.

ISO/IEC 23008-2:2017(E)

The list SingleLayerSeiList is set to consist of the payloadType values 3, 6, 9, 15, 16, 17, 19, 22, 23, 45, 47, 56, 128, 129, 131, 132, and 134 to 148, inclusive.

The list VclAssociatedSeiList is set to consist of the payloadType values 2, 3, 6, 9, 15, 16, 17, 19, 22, 23, 45, 47, 56, 128, 131, 132, and 134 to 148, inclusive.

The list PicUnitRepConSeiList is set to consist of the payloadType values 0, 1, 2, 6, 9, 15, 16, 17, 19, 22, 23, 45, 47, 56, 128, 129, 131, 132, 133, and 135 to 148, inclusive.

NOTE 3 SingleLayerSeiList consists of the payloadType values of the SEI messages specified in this annex excluding 0 (buffering period), 1 (picture timing), 4 (user data registered by Rec. ITU-T T.35), 5 (user data unregistered), 130 (decoding unit information), and 133 (scalable nesting). VclAssociatedSeiList consists of the payloadType values of the SEI messages that, when non-nested and contained in an SEI NAL unit, infer constraints on the NAL unit header of the SEI NAL unit on the basis of the NAL unit header of the associated VCL NAL unit. PicUnitRepConSeiList consists of the payloadType values of the SEI messages that are subject to the restriction on 8 repetitions per picture unit.

The semantics and persistence scope for each SEI message are specified in the semantics specification for each particular SEI message.

NOTE 4 Persistence information for SEI messages is informatively summarized in Table D.1.

Table D.1 — Persistence scope of SEI messages (informative)

SEI message	Persistence scope
Buffering period	The remainder of the bitstream
Picture timing	The access unit containing the SEI message
Pan-scan rectangle	Specified by the syntax of the SEI message
Filler payload	The access unit containing the SEI message
User data registered by Rec. ITU-T T.35	Unspecified
User data unregistered	Unspecified
Recovery point	Specified by the syntax of the SEI message
Scene information	The access unit containing the SEI message and up to but not including the next access unit, in decoding order, that contains a scene information SEI message
Picture snapshot	The access unit containing the SEI message
Progressive refinement segment start	Specified by the syntax of the SEI message
Progressive refinement segment end	The access unit containing the SEI message
Film grain characteristics	Specified by the syntax of the SEI message
Post-filter hint	The access unit containing the SEI message
Tone mapping information	Specified by the syntax of the SEI message
Frame packing arrangement	Specified by the syntax of the SEI message
Display orientation	Specified by the syntax of the SEI message
Green metadata	The CLVS containing the SEI message
Structure of pictures information	The set of pictures in the CLVS that correspond to entries listed in the SEI message
Decoded picture hash	The access unit containing the SEI message
Active parameter sets	The CVS containing the SEI message

Decoding unit information	The decoding unit containing the SEI message
Temporal sub-layer zero index	The access unit containing the SEI message
Scalable nesting	Depending on the nested SEI messages. Each nested SEI message has the same persistence scope as if the SEI message was not nested
Region refresh information	The set of VCL NAL units within the access unit starting from the VCL NAL unit following the SEI message up to but not including the VCL NAL unit following the next SEI NAL unit containing a region refresh information SEI message (if any)
No display	The access unit containing the SEI message
Time code	The access unit containing the SEI message
Mastering display colour volume	The CLVS containing the SEI message
Segmented rectangular frame packing arrangement	Specified by the syntax of the SEI message
Temporal motion-constrained tile sets	The CLVS containing the SEI message
Chroma resampling filter hint	The CLVS containing the SEI message
Knee function information	Specified by the syntax of the SEI message
Colour remapping information	Specified by the syntax of the SEI message
Deinterlaced field identification	One or more pictures associated with the access unit containing the SEI message
Content light level information	The CLVS containing the SEI message
Dependent random access point indication	The access unit containing the SEI message
Coded region completion	The current slice segment associated with the SEI message
Alternative transfer characteristics	The CLVS containing the SEI message
Ambient viewing environment	The CLVS containing the SEI message

It is a requirement of bitstream conformance that when a prefix SEI message with payloadType equal to 17 (progressive refinement segment end) or 22 (post-filter hint) is present in an access unit, a suffix SEI message with the same value of payloadType shall not be present in the same access unit.

It is a requirement of bitstream conformance that the following restrictions apply on containing of SEI messages in SEI NAL units:

- An SEI NAL unit containing an active parameter sets SEI message shall contain only one active parameter sets SEI message and shall not contain any other SEI messages.
- When an SEI NAL unit contains a non-nested buffering period SEI message, a non-nested picture timing SEI message, or a non-nested decoding unit information SEI message, the SEI NAL unit shall not contain any other SEI message with payloadType not equal to 0 (buffering period), 1 (picture timing), or 130 (decoding unit information).
- When an SEI NAL unit contains a nested buffering period SEI message, a nested picture timing SEI message, or a nested decoding unit information SEI message, the SEI NAL unit shall not contain any other SEI message with payloadType not equal to 0 (buffering period), 1 (picture timing), 130 (decoding unit information), or 133 (scalable nesting).

Let prevVclNalUnitInAu of an SEI NAL unit or an SEI message be the preceding VCL NAL unit in decoding order, if any, in the same access unit, and nextVclNalUnitInAu of an SEI NAL unit or an SEI message be the next VCL NAL unit in decoding order, if any, in the same access unit.

ISO/IEC 23008-2:2017(E)

It is a requirement of bitstream conformance that the following restrictions apply on decoding order of SEI messages:

- When an SEI NAL unit containing an active parameter sets SEI message is present in an access unit, it shall be the first SEI NAL unit that follows the `prevVclNalUnitInAu` of the SEI NAL unit and precedes the `nextVclNalUnitInAu` of the SEI NAL unit.
- When a non-nested buffering period SEI message is present in an access unit, it shall not follow any other SEI message that follows the `prevVclNalUnitInAu` of the buffering period SEI message and precedes the `nextVclNalUnitInAu` of the buffering period SEI message, other than an active parameter sets SEI message.
- When a non-nested picture timing SEI message is present in an access unit, it shall not follow any other SEI message that follows the `prevVclNalUnitInAu` of the picture timing SEI message and precedes the `nextVclNalUnitInAu` of the picture timing SEI message, other than an active parameter sets SEI message or a non-nested buffering period SEI message.
- When a non-nested decoding unit information SEI message is present in an access unit, it shall not follow any other SEI message in the same access unit that follows the `prevVclNalUnitInAu` of the decoding unit information SEI message and precedes the `nextVclNalUnitInAu` of the decoding unit information SEI message, other than an active parameter sets SEI message, a non-nested buffering period SEI message, or a non-nested picture timing SEI message.
- When a nested buffering period SEI message, a nested picture timing SEI message, or a nested decoding unit information SEI message is contained in a scalable nesting SEI message in an access unit, the scalable nesting SEI message shall not follow any other SEI message that follows the `prevVclNalUnitInAu` of the scalable nesting SEI message and precedes the `nextVclNalUnitInAu` of the scalable nesting SEI message, other than an active parameter sets SEI message, a non-nested buffering period SEI message, a non-nested picture timing SEI message, a non-nested decoding unit information SEI message, or another scalable nesting SEI message that contains a buffering period SEI message, a picture timing SEI message, or a decoding unit information SEI message.
- When `payloadType` is equal to 0 (buffering period), 1 (picture timing), or 130 (decoding unit information) for an SEI message, nested or non-nested, within the access unit, the SEI NAL unit containing the SEI message shall precede all NAL units of any picture unit that has `nuh_layer_id` greater than `highestAppLayerId`, where `highestAppLayerId` is the greatest value of `nuh_layer_id` of all the layers in all the operation points that the SEI message applies to.
- When `payloadType` is equal to any value among `VclAssociatedSeiList` for an SEI message, nested or non-nested, within the access unit, the SEI NAL unit containing the SEI message shall precede all NAL units of any picture unit that has `nuh_layer_id` greater than `highestAppLayerId`, where `highestAppLayerId` is the greatest value of `nuh_layer_id` of all the layers that the SEI message applies to.

The following applies on the applicable operation points or layers of SEI messages:

- For a non-nested SEI message, when `payloadType` is equal to 0 (buffering period) or 130 (decoding unit information), the non-nested SEI message applies to the operation point that has `OpTid` equal to the greatest value of `nuh_temporal_id_plus1` among all VCL NAL units in the bitstream, and that has `OpLayerIdList` containing all values of `nuh_layer_id` in all VCL units in the bitstream.
- An SEI message that is directly contained in a scalable nesting SEI message within an SEI NAL unit with `nuh_layer_id` equal to 0 and has `payloadType` is equal to 0 (buffering period), 1 (picture timing), or 130 (decoding unit information) applies as specified in Annex C to the layer set as indicated by the scalable nesting SEI message.

- For a non-nested SEI message, when payloadType is equal to 1 (picture timing), the frame field information carried in the syntax elements pic_struct, source_scan_type, and duplicate_flag, when present, in the non-nested picture timing SEI message applies to the base layer only, while the picture timing information carried in other syntax elements, when present, in the non-nested picture timing SEI message applies to the operation point that has OpTid equal to the greatest value of nuh_temporal_id_plus1 among all VCL NAL units in the bitstream, and that has OpLayerIdList containing all values of nuh_layer_id in all VCL units in the bitstream.
- For a non-nested SEI message, when payloadType is equal to any value among VclAssociatedSeiList, the non-nested SEI message applies to the layer for which the VCL NAL units have nuh_layer_id equal to the nuh_layer_id of the SEI NAL unit containing the SEI message.
- An active parameter sets SEI message, which cannot be nested, applies to all layers in the bitstream.

It is a requirement of bitstream conformance that the following restrictions apply on the values of nuh_layer_id and TemporalId of SEI NAL units:

- When a non-nested SEI message has payloadType equal to any value among VclAssociatedSeiList, the SEI NAL unit containing the non-nested SEI message shall have TemporalId equal to the TemporalId of the access unit containing the SEI NAL unit.
- When a non-nested SEI message has payloadType equal to 0, 1, 129, or 130, the SEI NAL unit containing the non-nested SEI message shall have nuh_layer_id equal to 0.
- When a non-nested SEI message has payloadType equal to any value among VclAssociatedSeiList, the SEI NAL unit containing the non-nested SEI message shall have nuh_layer_id and nuh_temporal_id_plus1 equal to the values of nuh_layer_id and nuh_temporal_id_plus1, respectively, of the VCL NAL unit associated with the SEI NAL unit.

NOTE 5 For an SEI NAL unit containing a scalable nesting SEI message, the values of TemporalId and nuh_layer_id are expected to be set equal to the lowest value of TemporalId and nuh_layer_id, respectively, of all the sub-layers or operation points the nested SEI messages apply to unless specified otherwise.

It is a requirement of bitstream conformance that the following restrictions apply on the presence of SEI messages between two VCL NAL units of a picture:

- When there is a prefix SEI message that has payloadType equal to any value among SingleLayerSeiList not equal to 134 (the region refresh information SEI message) or 146 (the coded region completion SEI message), and applies to a picture of a layer layerA present between two VCL NAL units of the picture in decoding order, there shall be a prefix SEI message that is of the same type and applies to the layer layerA in the same access unit preceding the first VCL NAL unit of the picture.
- When there is a suffix SEI message that has payloadType equal to 3 (filler payload), 17 (progressive refinement segment end), 22 (post filter hint), or 132 (decoded picture hash) and applies to a picture of a layer layerA present between two VCL NAL units of the picture in decoding order, there shall be a suffix SEI message that is of the same type and applies to the layer layerA present in the same access unit succeeding the last VCL NAL unit of the picture.

It is a requirement of bitstream conformance that the following restrictions apply on repetition of SEI messages:

- For each of the payloadType values included in PicUnitRepConSeiList, there shall be less than or equal to 8 identical sei_payload() syntax structures within a picture unit.

ISO/IEC 23008-2:2017(E)

- There shall be less than or equal to 8 identical `sei_payload()` syntax structures with `payloadType` equal to 130 within a decoding unit.
- The number of identical `sei_payload()` syntax structures with `payloadType` equal to 134 in a picture unit shall be less than or equal to the number of slice segments in the picture unit.

In the following subclauses of this annex, the following apply:

- The current SEI message refers to the particular SEI message.
- The current access unit refers to the access unit containing the current SEI message.

In the following subclauses of this annex, when a particular SEI message applies to a set of one or more layers (instead of a set of operation points), i.e. when the `payloadType` value is not equal to one of 0 (buffering period), 1 (picture timing), and 130 (decoding unit information), the following apply:

- The semantics apply independently to each particular layer with `nuh_layer_id` equal to `targetLayerId` of the layers to which the particular SEI message applies.
- The current layer refers to the layer with `nuh_layer_id` equal to `targetLayerId`.
- The current picture or the current decoded picture refers to the picture with `nuh_layer_id` equal to `targetLayerId` (i.e. in the current layer) in the current access unit.

In the following subclauses of this annex, when a particular SEI message applies to a set of one or more operation points (instead of a set of one or more layers), i.e. when the `payloadType` value is equal to 0 (buffering period), 1 (picture timing), or 130 (decoding unit information), the following apply:

- When the particular SEI message applies to an operation point that does not include the base layer (i.e. when the SEI message is contained in an SEI NAL unit with `nuh_layer_id` greater than 0), decoders conforming to a profile specified in Annex A and not supporting the INBLD capability specified in Annex F shall ignore that particular SEI message.
- The semantics apply independently to each particular operation point of the set of operation points to which the particular SEI message applies.
- The current operation point refers to the particular operation point.
- The terms "access unit" and "CVS" apply to the bitstream `BitstreamToDecode` that is the sub-bitstream of the particular operation point.

D.3.2 Buffering period SEI message semantics

A buffering period SEI message provides initial CPB removal delay and initial CPB removal delay offset information for initialization of the HRD at the position of the associated access unit in decoding order.

When the buffering period SEI message is non-nested or is directly contained in a scalable nesting SEI message within an SEI NAL unit with `nuh_layer_id` equal to 0 and the current access unit is a CRA or BLA access unit, let `skippedPictureList` be the list of skipped leading pictures consisting of the RASL pictures associated with the CRA or BLA access unit with which the buffering period SEI message is associated.

When the buffering period SEI message is non-nested or is directly contained in a scalable nesting SEI message within an SEI NAL unit with `nuh_layer_id` equal to 0, a picture is said to be a `notDiscardablePic` picture when the picture has `TemporalId` equal to 0, and is not a RASL, RADL, or SLNR picture.

When the buffering period SEI message is non-nested or is directly contained in a scalable nesting SEI message within an SEI NAL unit with `nuh_layer_id` equal to 0, the following applies for the buffering period SEI message syntax and semantics:

- The syntax elements `initial_cpb_removal_delay_length_minus1`, `au_cpb_removal_delay_length_minus1`, `dpb_output_delay_length_minus1`, and `sub_pic_hrd_params_present_flag`, and the variables `NalHrdBpPresentFlag` and `VclHrdBpPresentFlag` are found in or derived from syntax elements found in the `hrd_parameters()` syntax structure that is applicable to at least one of the operation points to which the buffering period SEI message applies.
- The variables `CpbSize[i]`, `BitRate[i]` and `CpbCnt` are derived from syntax elements found in the `sub_layer_hrd_parameters()` syntax structure that is applicable to at least one of the operation points to which the buffering period SEI message applies.
- Any two operation points that the buffering period SEI message applies to having different `OpTid` values `tIdA` and `tIdB` indicate that the values of `cpb_cnt_minus1[tIdA]` and `cpb_cnt_minus1[tIdB]` coded in the `hrd_parameters()` syntax structure(s) applicable to the two operation points are identical.
- Any two operation points that the buffering period SEI message applies to having different `OpLayerIdList` values `layerIdListA` and `layerIdListB` indicate that the values of `nal_hrd_parameters_present_flag` and `vcl_hrd_parameters_present_flag`, respectively, for the two `hrd_parameters()` syntax structures applicable to the two operation points are identical.
- The bitstream (or a part thereof) refers to the bitstream subset (or a part thereof) associated with any of the operation points to which the buffering period SEI message applies.

The presence of buffering period SEI messages for an operation point including the base layer is specified as follows:

- If `NalHrdBpPresentFlag` is equal to 1 or `VclHrdBpPresentFlag` is equal to 1, the following applies for each access unit in the CVS:
 - If the access unit is an IRAP access unit, a buffering period SEI message applicable to the operation point shall be associated with the access unit.
 - Otherwise, if the access unit contains a `notDiscardablePic`, a buffering period SEI message applicable to the operation point may or may not be associated with the access unit.
 - Otherwise, the access unit shall not be associated with a buffering period SEI message applicable to the operation point.
- Otherwise (`NalHrdBpPresentFlag` and `VclHrdBpPresentFlag` are both equal to 0), no access unit in the CVS shall be associated with a buffering period SEI message applicable to the operation point.

NOTE 1 For some applications, frequent presence of buffering period SEI messages may be desirable (e.g. for random access at an IRAP picture or a non-IRAP picture or for bitstream splicing).

bp_seq_parameter_set_id indicates and shall be equal to the `sps_seq_parameter_set_id` for the SPS that is active for the coded picture associated with the buffering period SEI message. The value of `bp_seq_parameter_set_id` shall be equal to the value of `pps_seq_parameter_set_id` in the PPS referenced by the `slice_pic_parameter_set_id` of the slice segment headers of the coded picture associated with the buffering period SEI message. The value of `bp_seq_parameter_set_id` shall be in the range of 0 to 15, inclusive.

irap_cpb_params_present_flag equal to 1 specifies the presence of the `nal_initial_alt_cpb_removal_delay[i]` and `nal_initial_alt_cpb_removal_offset[i]` or `vcl_initial_alt_cpb_removal_delay[i]` and `vcl_initial_alt_cpb_removal_offset[i]` syntax elements. When not present, the value of `irap_cpb_params_present_flag` is inferred to be equal to 0. When the associated

picture is neither a CRA picture nor a BLA picture, the value of `irap_cpb_params_present_flag` shall be equal to 0.

NOTE 2 The values of `sub_pic_hrd_params_present_flag` and `irap_cpb_params_present_flag` cannot be both equal to 1.

cpb_delay_offset specifies an offset to be used in the derivation of the nominal CPB removal times of access units following, in decoding order, the CRA or BLA access unit associated with the buffering period SEI message when no picture in `skippedPictureList` is present. The syntax element has a length in bits given by `au_cpb_removal_delay_length_minus1 + 1`. When not present, the value of `cpb_delay_offset` is inferred to be equal to 0.

dpb_delay_offset specifies an offset to be used in the derivation of the DPB output times of the CRA or BLA access unit associated with the buffering period SEI message when no picture in `skippedPictureList` is present. The syntax element has a length in bits given by `dpb_output_delay_length_minus1 + 1`. When not present, the value of `dpb_delay_offset` is inferred to be equal to 0.

When the current picture is not the first picture in the bitstream in decoding order, let `prevNonDiscardablePic` be the preceding picture in decoding order with `TemporalId` equal to 0 that is not a RASL, RADL, or SLNR picture.

concatenation_flag indicates, when the current picture is not the first picture in the bitstream in decoding order, whether the nominal CPB removal time of the current picture is determined relative to the nominal CPB removal time of the preceding picture with a buffering period SEI message or relative to the nominal CPB removal time of the picture `prevNonDiscardablePic`.

au_cpb_removal_delay_delta_minus1 plus 1, when the current picture is not the first picture in the bitstream in decoding order, specifies a CPB removal delay increment value relative to the nominal CPB removal time of the picture `prevNonDiscardablePic`. This syntax element has a length in bits given by `au_cpb_removal_delay_length_minus1 + 1`.

When the current picture contains a buffering period SEI message and `concatenation_flag` is equal to 0 and the current picture is not the first picture in the bitstream in decoding order, it is a requirement of bitstream conformance that the following constraint apply:

- If the picture `prevNonDiscardablePic` is not associated with a buffering period SEI message, the `au_cpb_removal_delay_minus1` of the current picture shall be equal to the `au_cpb_removal_delay_minus1` of `prevNonDiscardablePic` plus `au_cpb_removal_delay_delta_minus1 + 1`.
- Otherwise, `au_cpb_removal_delay_minus1` shall be equal to `au_cpb_removal_delay_delta_minus1`.

NOTE 3 When the current picture contains a buffering period SEI message and `concatenation_flag` is equal to 1, the `au_cpb_removal_delay_minus1` for the current picture is not used. The above-specified constraint can, under some circumstances, make it possible to splice bitstreams (that use suitably-designed referencing structures) by simply changing the value of `concatenation_flag` from 0 to 1 in the buffering period SEI message for an IRAP picture at the splicing point. When `concatenation_flag` is equal to 0, the above-specified constraint enables the decoder to check whether the constraint is satisfied as a way to detect the loss of the picture `prevNonDiscardablePic`.

nal_initial_cpb_removal_delay[i] and **nal_initial_alt_cpb_removal_delay[i]** specify the default and the alternative initial CPB removal delays, respectively, for the *i*-th CPB when the NAL HRD parameters are in use. The syntax elements have a length in bits given by `initial_cpb_removal_delay_length_minus1 + 1`, and are in units of a 90 kHz clock. The values of the syntax elements shall not be equal to 0 and shall be less than or equal to $90000 * (\text{CpbSize}[i] \div \text{BitRate}[i])$, the time-equivalent of the CPB size in 90 kHz clock units.

nal_initial_cpb_removal_offset[i] and **nal_initial_alt_cpb_removal_offset[i]** specify the default and the alternative initial CPB removal offsets, respectively, for the *i*-th CPB when the NAL HRD parameters

are in use. The syntax elements have a length in bits given by $\text{initial_cpb_removal_delay_length_minus1} + 1$ and are in units of a 90 kHz clock.

Over the entire CVS, the sum of $\text{nal_initial_cpb_removal_delay}[i]$ and $\text{nal_initial_cpb_removal_offset}[i]$ shall be constant for each value of i , and the sum of $\text{nal_initial_alt_cpb_removal_delay}[i]$ and $\text{nal_initial_alt_cpb_removal_offset}[i]$ shall be constant for each value of i .

vcl_initial_cpb_removal_delay $[i]$ and **vcl_initial_alt_cpb_removal_delay** $[i]$ specify the default and the alternative initial CPB removal delays, respectively, for the i -th CPB when the VCL HRD parameters are in use. The syntax elements have a length in bits given by $\text{initial_cpb_removal_delay_length_minus1} + 1$, and are in units of a 90 kHz clock. The values of the syntax elements shall not be equal to 0 and shall be less than or equal to $90000 * (\text{CpbSize}[i] \div \text{BitRate}[i])$, the time-equivalent of the CPB size in 90 kHz clock units.

vcl_initial_cpb_removal_offset $[i]$ and **vcl_initial_alt_cpb_removal_offset** $[i]$ specify the default and the alternative initial CPB removal offsets, respectively, for the i -th CPB when the VCL HRD parameters are in use. The syntax elements have a length in bits given by $\text{initial_cpb_removal_delay_length_minus1} + 1$ and are in units of a 90 kHz clock.

Over the entire CVS, the sum of $\text{vcl_initial_cpb_removal_delay}[i]$ and $\text{vcl_initial_cpb_removal_offset}[i]$ shall be constant for each value of i , and the sum of $\text{vcl_initial_alt_cpb_removal_delay}[i]$ and $\text{vcl_initial_alt_cpb_removal_offset}[i]$ shall be constant for each value of i .

Encoders are recommended not to include **irap_cpb_params_present_flag** equal to 1 in buffering period SEI messages associated with a CRA or BLA picture for which at least one of its associated RASL pictures follows one or more of its associated RADL pictures in decoding order.

use_alt_cpb_params_flag may be used to derive the value of **UseAltCpbParamsFlag**. When **irap_cpb_params_present_flag** is equal to 0, **use_alt_cpb_params_flag** shall not be equal to 1. When **use_alt_cpb_params_flag** is not present, it is inferred to be equal to 0.

NOTE 4 The syntax element **use_alt_cpb_params_flag** may be present in the payload extension of the buffering period SEI message. Decoders conforming to profiles specified in Annex A may ignore this syntax element.

D.3.3 Picture timing SEI message semantics

The picture timing SEI message provides CPB removal delay and DPB output delay information for the access unit associated with the SEI message.

When the buffering period SEI message is non-nested or is directly contained in a scalable nesting SEI message within an SEI NAL unit with **nuh_layer_id** equal to 0, the following applies for the picture timing SEI message syntax and semantics:

- The syntax elements **sub_pic_hrd_params_present_flag**, **sub_pic_cpb_params_in_pic_timing_sei_flag**, **au_cpb_removal_delay_length_minus1**, **dpb_output_delay_length_minus1**, **dpb_output_delay_du_length_minus1**, **du_cpb_removal_delay_increment_length_minus1**, and the variable **CpbDpbDelaysPresentFlag** are found in or derived from syntax elements found in the **hrd_parameters()** syntax structure that is applicable to at least one of the operation points to which the picture timing SEI message applies.
- The bitstream (or a part thereof) refers to the bitstream subset (or a part thereof) associated with any of the operation points to which the picture timing SEI message applies.

NOTE 1 The syntax of the picture timing SEI message is dependent on the content of the **hrd_parameters()** syntax structures applicable to the operation points to which the picture timing SEI message applies. These **hrd_parameters()** syntax structures are in either or both of the VPS and the SPS that are active for the coded picture associated with the picture timing SEI message. When the picture timing SEI message is associated with an IRAP access unit with **NoRaslOutputFlag** equal to 1, unless it is preceded by an active parameter sets SEI message within the same access unit, the activation of the VPS and the SPS (and, for IRAP pictures with **NoRaslOutputFlag** equal to 1 that are not the first picture in the bitstream in decoding order, the determination that the coded picture is an IRAP access unit with **NoRaslOutputFlag** equal to 1) does not occur until the decoding of the first

ISO/IEC 23008-2:2017(E)

coded slice segment NAL unit of the coded picture. Since the coded slice segment NAL unit of the coded picture follows the picture timing SEI message in NAL unit order, there may be cases in which it is necessary for a decoder to store the RBSP containing the picture timing SEI message until determining the active VPS and the active SPS for the coded picture, and then perform the parsing of the picture timing SEI message.

The presence of picture timing SEI messages for an operation point including the base layer is specified as follows.

- If `frame_field_info_present_flag` is equal to 1 or `CpbDpbDelaysPresentFlag` is equal to 1, a picture timing SEI message applicable to the operation point shall be associated with every access unit in the CVS.
- Otherwise, in the CVS there shall be no access unit that is associated with a picture timing SEI message applicable to the operation point.

When the picture timing SEI message is not nested or is directly contained in a scalable nesting SEI message within an SEI NAL unit with `nuh_layer_id` equal to 0, the semantics of `pic_struct`, `source_scan_type`, and `duplicate_flag` apply to the picture with `nuh_layer_id` equal to 0 and are specified in the following paragraphs.

NOTE 2 When the picture timing SEI message is directly contained in a scalable nesting SEI message within an SEI NAL unit with `nuh_layer_id` greater than 0 or is contained in a bitstream partition nesting SEI message specified in Annex F, the semantics of `pic_struct`, `source_scan_type`, and `duplicate_flag` are specified in Annex F. The frame-field information SEI message specified in Annex F can be used to indicate `pic_struct`, `source_scan_type`, and `duplicate_flag` for non-base layers.

pic_struct indicates whether a picture should be displayed as a frame or as one or more fields and, for the display of frames when `fixed_pic_rate_within_cvs_flag` is equal to 1, may indicate a frame doubling or tripling repetition period for displays that use a fixed frame refresh interval equal to `DpbOutputElementalInterval[n]` as given by Formula (E-70). The interpretation of `pic_struct` is specified in Table D.2. Values of `pic_struct` that are not listed in Table D.2 are reserved for future use by ITU-T | ISO/IEC and shall not be present in bitstreams conforming to this version of this document. Decoders shall ignore reserved values of `pic_struct`.

When present, it is a requirement of bitstream conformance that the value of `pic_struct` shall be constrained such that exactly one of the following conditions is true.

- The value of `pic_struct` is equal to 0, 7, or 8 for all pictures in the CVS.
- The value of `pic_struct` is equal to 1, 2, 9, 10, 11, or 12 for all pictures in the CVS.
- The value of `pic_struct` is equal to 3, 4, 5, or 6 for all pictures in the CVS.

When `fixed_pic_rate_within_cvs_flag` is equal to 1, frame doubling is indicated by `pic_struct` equal to 7, which indicates that the frame should be displayed two times consecutively on displays with a frame refresh interval equal to `DpbOutputElementalInterval[n]` as given by Formula (E-70), and frame tripling is indicated by `pic_struct` equal to 8, which indicates that the frame should be displayed three times consecutively on displays with a frame refresh interval equal to `DpbOutputElementalInterval[n]` as given by Formula (E-70).

NOTE 3 Frame doubling can be used to facilitate the display, for example, of 25 Hz progressive-scan video on a 50 Hz progressive-scan display or 30 Hz progressive-scan video on a 60 Hz progressive-scan display. Using frame doubling and frame tripling in alternating combination on every other frame can be used to facilitate the display of 24 Hz progressive-scan video on a 60 Hz progressive-scan display.

The nominal vertical and horizontal sampling locations of samples in top and bottom fields for 4:2:0, 4:2:2, and 4:4:4 chroma formats are shown in Figure D.1, Figure D.2, and Figure D.3, respectively.

Association indicators for fields (`pic_struct` equal to 9 through 12) provide hints to associate fields of complementary parity together as frames. The parity of a field can be top or bottom, and the parity of

two fields is considered complementary when the parity of one field is top and the parity of the other field is bottom.

When `frame_field_info_present_flag` is equal to 1, it is a requirement of bitstream conformance that the constraints specified in the third column of Table D.2 shall apply.

NOTE 4 When `frame_field_info_present_flag` is equal to 0, then in many cases default values may be inferred or indicated by other means. In the absence of other indications of the intended display type of a picture, the decoder should infer the value of `pic_struct` as equal to 0 when `frame_field_info_present_flag` is equal to 0.

source_scan_type equal to 1 indicates that the source scan type of the associated picture should be interpreted as progressive. `source_scan_type` equal to 0 indicates that the source scan type of the associated picture should be interpreted as interlaced. `source_scan_type` equal to 2 indicates that the source scan type of the associated picture is unknown or unspecified. `source_scan_type` equal to 3 is reserved for future use by ITU-T | ISO/IEC and shall not be present in bitstreams conforming to this version of this document. Decoders conforming to this version of this document shall interpret the value 3 for `source_scan_type` as equivalent to the value 2.

The following applies to the semantics of `source_scan_type`.

- If `general_progressive_source_flag` is equal to 0 and `general_interlaced_source_flag` is equal to 1, the value of `source_scan_type` shall be equal to 0 when present, and should be inferred to be equal to 0 when not present.
- Otherwise, if `general_progressive_source_flag` is equal to 1 and `general_interlaced_source_flag` is equal to 0, the value of `source_scan_type` shall be equal to 1 when present, and should be inferred to be equal to 1 when not present.
- Otherwise, when `general_progressive_source_flag` is equal to 0 and `general_interlaced_source_flag` is equal to 0, the value of `source_scan_type` shall be equal to 2 when present, and should be inferred to be equal to 2 when not present.

duplicate_flag equal to 1 indicates that the current picture is indicated to be a duplicate of a previous picture in output order. `duplicate_flag` equal to 0 indicates that the current picture is not indicated to be a duplicate of a previous picture in output order.

NOTE 5 The `duplicate_flag` is expected to be used to mark coded pictures known to have originated from a repetition process such as 3:2 pull-down or other such duplication and picture rate interpolation methods. This flag would commonly be used when a video feed is encoded as a field sequence in a "transport pass-through" fashion, with known duplicate pictures tagged by setting `duplicate_flag` equal to 1.

NOTE 6 When `field_seq_flag` is equal to 1 and `duplicate_flag` is equal to 1, this is expected to be interpreted as an indication that the access unit contains a duplicated field of the previous field in output order with the same parity as the current field unless a pairing is otherwise indicated by the use of a `pic_struct` value in the range of 9 to 12, inclusive.

Table D.2 — Interpretation of `pic_struct`

Value	Indicated display of picture	Restrictions
0	(progressive) frame	<code>field_seq_flag</code> shall be equal to 0
1	top field	<code>field_seq_flag</code> shall be equal to 1
2	bottom field	<code>field_seq_flag</code> shall be equal to 1
3	top field, bottom field, in that order	<code>field_seq_flag</code> shall be equal to 0
4	bottom field, top field, in that order	<code>field_seq_flag</code> shall be equal to 0

5	top field, bottom field, top field repeated, in that order	field_seq_flag shall be equal to 0
6	bottom field, top field, bottom field repeated, in that order	field_seq_flag shall be equal to 0
7	frame doubling	field_seq_flag shall be equal to 0 fixed_pic_rate_within_cvs_flag shall be equal to 1
8	frame tripling	field_seq_flag shall be equal to 0 fixed_pic_rate_within_cvs_flag shall be equal to 1
9	top field paired with previous bottom field in output order	field_seq_flag shall be equal to 1
10	bottom field paired with previous top field in output order	field_seq_flag shall be equal to 1
11	top field paired with next bottom field in output order	field_seq_flag shall be equal to 1
12	bottom field paired with next top field in output order	field_seq_flag shall be equal to 1

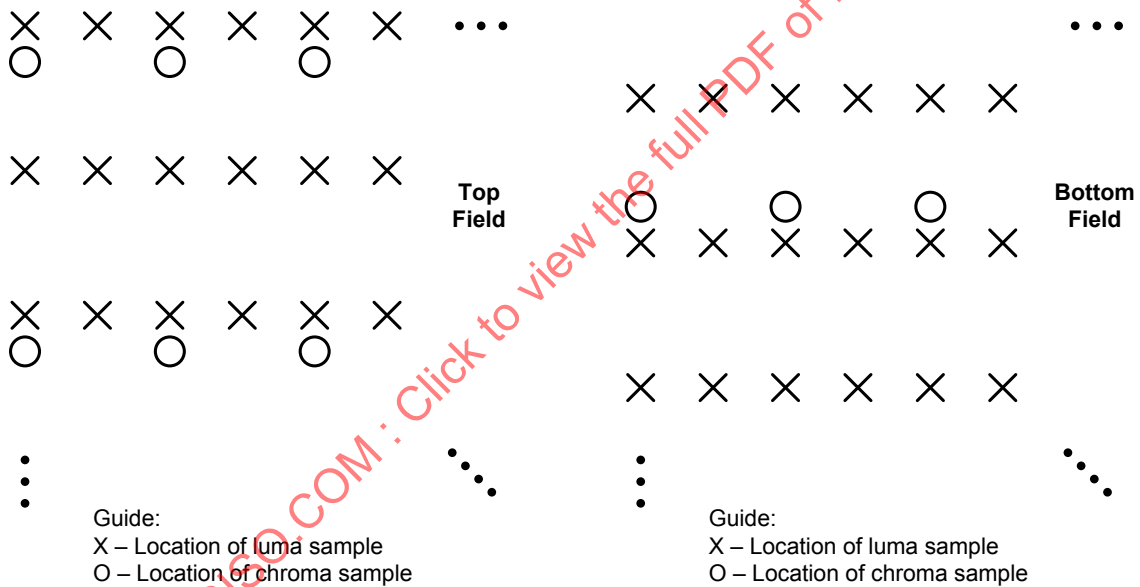

Figure D.1 — Nominal vertical and horizontal sampling locations of 4:2:0 samples in top and bottom fields

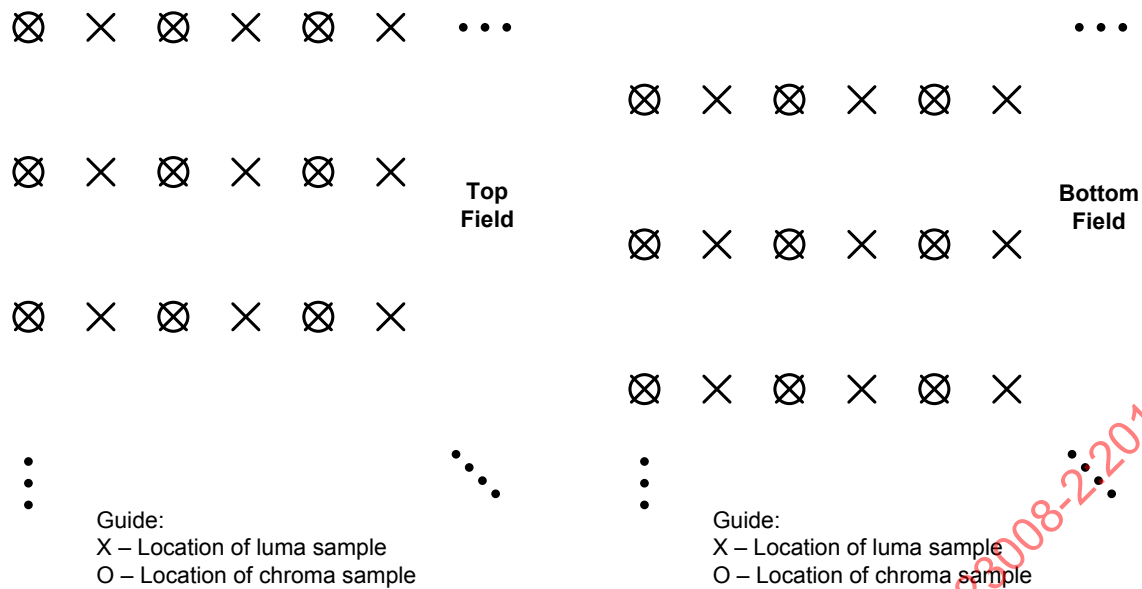

Figure D.2 — Nominal vertical and horizontal sampling locations of 4:2:2 samples in top and bottom fields

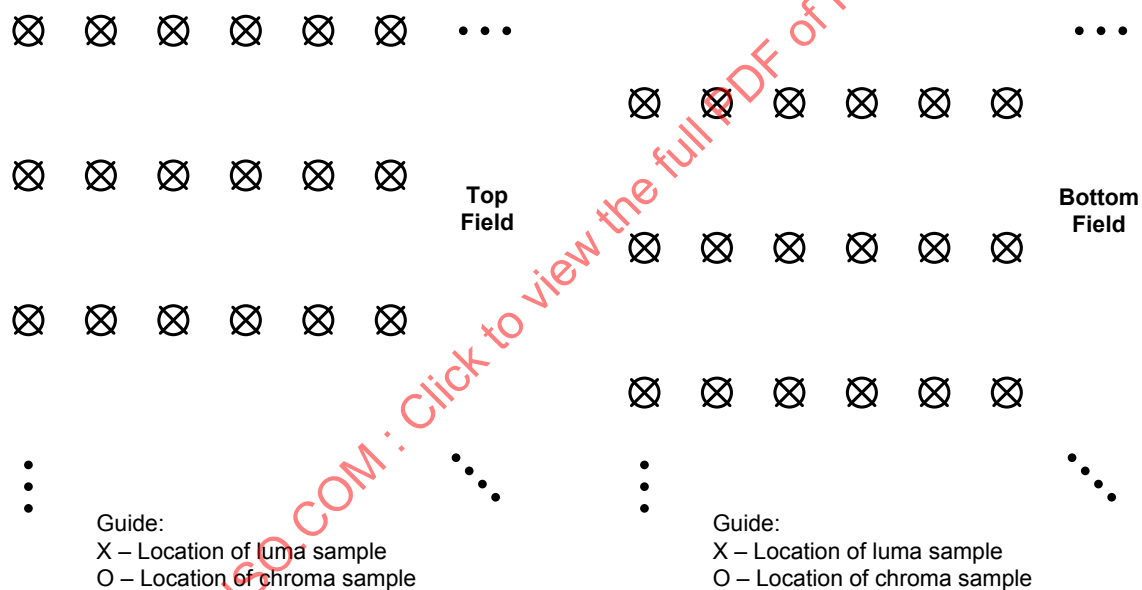

Figure D.3 — Nominal vertical and horizontal sampling locations of 4:4:4 samples in top and bottom fields

au_cpb_removal_delay_minus1 plus 1 is used to calculate the number of clock ticks between the nominal CPB removal times of the access unit associated with the picture timing SEI message and the preceding access unit in decoding order that contained a buffering period SEI message. This value is also used to calculate an earliest possible time of arrival of access unit data into the CPB for the HSS. The syntax element is a fixed length code whose length in bits is given by $\text{au_cpb_removal_delay_length_minus1} + 1$.

NOTE 7 The value of **au_cpb_removal_delay_length_minus1** that determines the length (in bits) of the syntax element **au_cpb_removal_delay_minus1** is the value of **au_cpb_removal_delay_length_minus1** coded in the VPS or the SPS that is active for the coded picture associated with the picture timing SEI message, although the preceding access unit containing a buffering period SEI message may be an access unit of a different CVS.

ISO/IEC 23008-2:2017(E)

The variable `BpResetFlag` of the current picture is derived as follows.

- If the current picture is associated with a buffering period SEI message that is applicable to at least one of the operation points to which the picture timing SEI message applies, `BpResetFlag` is set equal to 1.
- Otherwise, `BpResetFlag` is set equal to 0.

The variables `AuCpbRemovalDelayMsb` and `AuCpbRemovalDelayVal` of the current picture are derived as follows.

- If the current access unit is the access unit that initializes the HRD, `AuCpbRemovalDelayMsb` and `AuCpbRemovalDelayVal` are both set equal to 0.
- Otherwise, let the picture `prevNonDiscardablePic` be the previous picture in decoding order that has `TemporalId` equal to 0 that is not a RASL, RADL, or SLNR picture, let `prevAuCpbRemovalDelayMinus1`, `prevAuCpbRemovalDelayMsb`, and `prevBpResetFlag` be set equal to the values of `au_cpb_removal_delay_minus1`, `AuCpbRemovalDelayMsb`, and `BpResetFlag`, respectively, for the picture `prevNonDiscardablePic`, and the following apply:

- `AuCpbRemovalDelayMsb` is derived as follows:

```
if( prevBpResetFlag )
    AuCpbRemovalDelayMsb = 0
else if( au_cpb_removal_delay_minus1 <= prevAuCpbRemovalDelayMinus1 )
    AuCpbRemovalDelayMsb = prevAuCpbRemovalDelayMsb + 2au_cpb_removal_delay_length_minus1 + 1(D-1)
else
    AuCpbRemovalDelayMsb = prevAuCpbRemovalDelayMsb
```

- `AuCpbRemovalDelayVal` is derived as follows:

$$\text{AuCpbRemovalDelayVal} = \text{AuCpbRemovalDelayMsb} + \text{au_cpb_removal_delay_minus1} + 1(D-2)$$

The value of `AuCpbRemovalDelayVal` shall be in the range of 1 to 2^{32} , inclusive.

pic_dpb_output_delay is used to compute the DPB output time of the picture when `SubPicHrdFlag` is equal to 0. It specifies how many clock ticks to wait after removal of the last decoding unit in an access unit from the CPB before the decoded picture is output from the DPB.

NOTE 8 A picture is not removed from the DPB at its output time when it is still marked as “used for short-term reference” or “used for long-term reference”.

The length of the syntax element `pic_dpb_output_delay` is given in bits by `dpb_output_delay_length_minus1 + 1`. When `sps_max_dec_pic_buffering_minus1[minTid]` is equal to 0, where `minTid` is the minimum of the `OpTid` values of all operation points the picture timing SEI message applies to, `pic_dpb_output_delay` shall be equal to 0.

The output time derived from the `pic_dpb_output_delay` of any picture that is output from an output timing conforming decoder shall precede the output time derived from the `pic_dpb_output_delay` of all pictures in any subsequent CVS in decoding order.

The picture output order established by the values of this syntax element shall be the same order as established by the values of `PicOrderCntVal`.

For pictures that are not output by the “bumping” process because they precede, in decoding order, an IRAP picture with `NoRaslOutputFlag` equal to 1 that has `no_output_of_prior_pics_flag` equal to 1 or inferred to be equal to 1, the output times derived from `pic_dpb_output_delay` shall be increasing with increasing value of `PicOrderCntVal` relative to all pictures within the same CVS.

pic_dpb_output_du_delay is used to compute the DPB output time of the picture when SubPicHrdFlag is equal to 1. It specifies how many sub clock ticks to wait after removal of the last decoding unit in an access unit from the CPB before the decoded picture is output from the DPB.

The length of the syntax element **pic_dpb_output_du_delay** is given in bits by **dpb_output_delay_du_length_minus1 + 1**.

The output time derived from the **pic_dpb_output_du_delay** of any picture that is output from an output timing conforming decoder shall precede the output time derived from the **pic_dpb_output_du_delay** of all pictures in any subsequent CVS in decoding order.

The picture output order established by the values of this syntax element shall be the same order as established by the values of PicOrderCntVal.

For pictures that are not output by the "bumping" process because they precede, in decoding order, an IRAP picture with NoRasOutputFlag equal to 1 that has **no_output_of_prior_pics_flag** equal to 1 or inferred to be equal to 1, the output times derived from **pic_dpb_output_du_delay** shall be increasing with increasing value of PicOrderCntVal relative to all pictures within the same CVS.

For any two pictures in the CVS, the difference between the output times of the two pictures when SubPicHrdFlag is equal to 1 shall be identical to the same difference when SubPicHrdFlag is equal to 0.

num_decoding_units_minus1 plus 1 specifies the number of decoding units in the access unit the picture timing SEI message is associated with. The value of **num_decoding_units_minus1** shall be in the range of 0 to PicSizeInCtbsY - 1, inclusive.

du_common_cpb_removal_delay_flag equal to 1 specifies that the syntax element **du_common_cpb_removal_delay_increment_minus1** is present. **du_common_cpb_removal_delay_flag** equal to 0 specifies that the syntax element **du_common_cpb_removal_delay_increment_minus1** is not present.

du_common_cpb_removal_delay_increment_minus1 plus 1 specifies the duration, in units of clock sub-ticks (see E.3.2), between the nominal CPB removal times of any two consecutive decoding units in decoding order in the access unit associated with the picture timing SEI message. This value is also used to calculate an earliest possible time of arrival of decoding unit data into the CPB for the HSS, as specified in Annex C or F.13. The syntax element is a fixed length code whose length in bits is given by **du_cpb_removal_delay_increment_length_minus1 + 1**.

num_nalus_in_du_minus1[i] plus 1 specifies the number of NAL units in the i-th decoding unit of the access unit the picture timing SEI message is associated with. The value of **num_nalus_in_du_minus1**[i] shall be in the range of 0 to PicSizeInCtbsY - 1, inclusive.

The first decoding unit of the access unit consists of the first **num_nalus_in_du_minus1**[0] + 1 consecutive NAL units in decoding order in the access unit. The i-th (with i greater than 0) decoding unit of the access unit consists of the **num_nalus_in_du_minus1**[i] + 1 consecutive NAL units immediately following the last NAL unit in the previous decoding unit of the access unit, in decoding order. There shall be at least one VCL NAL unit in each decoding unit. All non-VCL NAL units associated with a VCL NAL unit shall be included in the same decoding unit as the VCL NAL unit.

du_cpb_removal_delay_increment_minus1[i] plus 1 specifies the duration, in units of clock sub-ticks, between the nominal CPB removal times of the (i + 1)-th decoding unit and the i-th decoding unit, in decoding order, in the access unit associated with the picture timing SEI message. This value is also used to calculate an earliest possible time of arrival of decoding unit data into the CPB for the HSS, as specified in Annex C or F.13. The syntax element is a fixed length code whose length in bits is given by **du_cpb_removal_delay_increment_length_minus1 + 1**.

D.3.4 Pan-scan rectangle SEI message semantics

The pan-scan rectangle SEI message syntax elements specify the coordinates of one or more rectangles relative to the conformance cropping window specified by the active SPS. Each coordinate is specified in units of one-sixteenth luma sample spacing relative to the luma sampling grid.

pan_scan_rect_id contains an identifying number that may be used to identify the purpose of the one or more pan-scan rectangles (for example, to identify the one or more rectangles as the area to be shown on a particular display device or as the area that contains a particular actor in the scene). The value of **pan_scan_rect_id** shall be in the range of 0 to $2^{32} - 2$, inclusive.

Values of **pan_scan_rect_id** from 0 to 255 and from 512 to $2^{31} - 1$ may be used as determined by the application. Values of **pan_scan_rect_id** from 256 to 511 and from 2^{31} to $2^{32} - 2$ are reserved for future use by ITU-T | ISO/IEC. Decoders encountering a value of **pan_scan_rect_id** in the range of 256 to 511, inclusive, or in the range of 2^{31} to $2^{32} - 2$, inclusive, shall ignore it.

pan_scan_rect_cancel_flag equal to 1 indicates that the SEI message cancels the persistence of any previous pan-scan rectangle SEI message in output order that applies to the current layer. **pan_scan_rect_cancel_flag** equal to 0 indicates that pan-scan rectangle information follows.

pan_scan_cnt_minus1 specifies the number of pan-scan rectangles that are specified by the SEI message. **pan_scan_cnt_minus1** shall be in the range of 0 to 2, inclusive.

pan_scan_cnt_minus1 equal to 0 indicates that a single pan-scan rectangle is specified that applies to the decoded pictures that are within the persistence scope of the current SEI message. When **field_seq_flag** is equal to 1, **pan_scan_cnt_minus1** shall be equal to 0.

pan_scan_cnt_minus1 equal to 1 indicates that two pan-scan rectangles are specified that apply to the decoded pictures that are within the persistence scope of the current SEI message and that are associated with picture timing SEI messages having **pic_struct** equal to 3 or 4. The first rectangle applies to the first field of a frame in output order and the second rectangle applies to the second field of a frame in output order, where the output order between two fields in one frame is as shown in Table D.2 for **pic_struct** equal to 3 or 4.

pan_scan_cnt_minus1 equal to 2 indicates that three pan-scan rectangles are specified that apply to the decoded pictures that are within the persistence scope of the current SEI message and that are associated with picture timing SEI messages having **pic_struct** equal to 5 or 6. The first rectangle applies to the first field of the frame in output order, the second rectangle applies to the second field of the frame in output order, and the third rectangle applies to a repetition of the first field as a third field in output order, where the output order of fields in one frame is as shown in Table D.2 for **pic_struct** equal to 5 or 6.

pan_scan_rect_left_offset[i], **pan_scan_rect_right_offset[i]**, **pan_scan_rect_top_offset[i]**, and **pan_scan_rect_bottom_offset[i]**, specify, as signed integer quantities in units of one-sixteenth sample spacing relative to the luma sampling grid, the location of the *i*-th pan-scan rectangle. The values of each of these four syntax elements shall be in the range of $-2^{31} + 1$ to $2^{31} - 1$, inclusive.

The pan-scan rectangle is specified, in units of one-sixteenth sample spacing relative to a luma sampling grid, as the region with horizontal coordinates from $16 * \text{SubWidthC} * \text{conf_win_left_offset} + \text{pan_scan_rect_left_offset}[i]$ to $16 * (\text{CtbSizeY} * \text{PicWidthInCtbsY} - \text{SubWidthC} * \text{conf_win_right_offset}) + \text{pan_scan_rect_right_offset}[i] - 1$ and with vertical coordinates from $16 * \text{SubHeightC} * \text{conf_win_top_offset} + \text{pan_scan_rect_top_offset}[i]$ to $16 * (\text{CtbSizeY} * \text{PicHeightInCtbsY} - \text{SubHeightC} * \text{conf_win_bottom_offset}) + \text{pan_scan_rect_bottom_offset}[i] - 1$, inclusive. The value of $16 * \text{SubWidthC} * \text{conf_win_left_offset} + \text{pan_scan_rect_left_offset}[i]$ shall be less than or equal to $16 * (\text{CtbSizeY} * \text{PicWidthInCtbsY} - \text{SubWidthC} * \text{conf_win_right_offset}) + \text{pan_scan_rect_right_offset}[i] - 1$, and the value of $16 * \text{SubHeightC} * \text{conf_win_top_offset} + \text{pan_scan_rect_top_offset}[i]$ shall be less than or equal to $16 * (\text{CtbSizeY} * \text{PicHeightInCtbsY} - \text{SubHeightC} * \text{conf_win_bottom_offset}) + \text{pan_scan_rect_bottom_offset}[i] - 1$.

When the pan-scan rectangular area includes samples outside of the conformance cropping window, the region outside of the conformance cropping window may be filled with synthesized content (such as black video content or neutral grey video content) for display.

pan_scan_rect_persistence_flag specifies the persistence of the pan-scan rectangle SEI message for the current layer.

pan_scan_rect_persistence_flag equal to 0 specifies that the pan-scan rectangle information applies to the current decoded picture only.

Let picA be the current picture. pan_scan_rect_persistence_flag equal to 1 specifies that the pan-scan rectangle information persists for the current layer in output order until any of the following conditions are true.

- A new CLVS of the current layer begins.
- The bitstream ends.
- A picture picB in the current layer in an access unit containing a pan-scan rectangle SEI message with the same value of pan_scan_rect_id and applicable to the current layer is output for which PicOrderCnt(picB) is greater than PicOrderCnt(picA), where PicOrderCnt(picB) and PicOrderCnt(picA) are the PicOrderCntVal values of picB and picA, respectively, immediately after the invocation of the decoding process for picture order count for picB.

D.3.5 Filler payload SEI message semantics

This SEI message contains a series of payloadSize bytes of value 0xFF, which can be discarded.

ff_byte shall be a byte having the value 0xFF.

D.3.6 User data registered by Rec. ITU-T T.35 SEI message semantics

This SEI message contains user data registered as specified in Rec. ITU-T T.35, the contents of which are not specified in this document.

itu_t_t35_country_code shall be a byte having a value specified as a country code by Rec. ITU-T T.35 Annex A.

itu_t_t35_country_code_extension_byte shall be a byte having a value specified as a country code by Rec. ITU-T T.35 Annex B.

itu_t_t35_payload_byte shall be a byte containing data registered as specified in Rec. ITU-T T.35.

The ITU-T T.35 terminal provider code and terminal provider oriented code shall be contained in the first one or more bytes of the itu_t_t35_payload_byte, in the format specified by the Administration that issued the terminal provider code. Any remaining itu_t_t35_payload_byte data shall be data having syntax and semantics as specified by the entity identified by the ITU-T T.35 country code and terminal provider code.

D.3.7 User data unregistered SEI message semantics

This SEI message contains unregistered user data identified by a UUID, the contents of which are not specified in this document.

uuid_iso_iec_11578 shall have a value specified as a UUID according to the procedures of ISO/IEC 11578:1996, Annex A.

user_data_payload_byte shall be a byte containing data having syntax and semantics as specified by the UUID generator.

D.3.8 Recovery point SEI message semantics

The recovery point SEI message assists a decoder in determining when the decoding process will produce acceptable pictures for display after the decoder initiates random access or after the encoder indicates a broken link in the CVS. When the decoding process is started with the access unit in decoding order associated with the recovery point SEI message, all decoded pictures at or subsequent

to the recovery point in output order specified in this SEI message are indicated to be correct or approximately correct in content. Decoded pictures produced by random access at or before the picture associated with the recovery point SEI message need not be correct in content until the indicated recovery point, and the operation of the decoding process starting at the picture associated with the recovery point SEI message may contain references to pictures unavailable in the decoded picture buffer.

In addition, by use of the `broken_link_flag`, the recovery point SEI message can indicate to the decoder the location of some pictures in the bitstream that can result in serious visual artefacts when displayed, even when the decoding process was begun at the location of a previous IRAP access unit in decoding order.

NOTE 1 The `broken_link_flag` can be used by encoders to indicate the location of a point after which the decoding process for the decoding of some pictures may cause references to pictures that, though available for use in the decoding process, are not the pictures that were used for reference when the bitstream was originally encoded (e.g. due to a splicing operation performed during the generation of the bitstream).

When random access is performed to start decoding from the access unit associated with the recovery point SEI message, the decoder operates as if the associated picture was the first picture in the bitstream in decoding order, and the variables `prevPicOrderCntLsb` and `prevPicOrderCntMsb` used in derivation of `PicOrderCntVal` are both set equal to 0.

NOTE 2 When HRD information is present in the bitstream, a buffering period SEI message is expected to be associated with the access unit associated with the recovery point SEI message in order to establish initialization of the HRD buffer model after a random access.

Any SPS or PPS RBSP that is referred to by a picture associated with a recovery point SEI message or by any picture following such a picture in decoding order shall be available to the decoding process prior to its activation, regardless of whether or not the decoding process is started at the beginning of the bitstream or with the access unit, in decoding order, that is associated with the recovery point SEI message.

recovery_poc_cnt specifies the recovery point of decoded pictures in output order. If there is a picture `picA` that follows the current picture (i.e. the picture associated with the current SEI message) in decoding order in the CVS and that has `PicOrderCntVal` equal to the `PicOrderCntVal` of the current picture plus the value of `recovery_poc_cnt`, the picture `picA` is referred to as the recovery point picture. Otherwise, the first picture in output order that has `PicOrderCntVal` greater than the `PicOrderCntVal` of the current picture plus the value of `recovery_poc_cnt` is referred to as the recovery point picture. The recovery point picture shall not precede the current picture in decoding order. All decoded pictures in output order are indicated to be correct or approximately correct in content starting at the output order position of the recovery point picture. The value of `recovery_poc_cnt` shall be in the range of $-\text{MaxPicOrderCntLsb} / 2$ to $\text{MaxPicOrderCntLsb} / 2 - 1$, inclusive.

exact_match_flag indicates whether decoded pictures at and subsequent to the specified recovery point in output order derived by starting the decoding process at the access unit associated with the recovery point SEI message will be an exact match to the pictures that would be produced by starting the decoding process at the location of a previous IRAP access unit, if any, in the bitstream. The value 0 indicates that the match may not be exact and the value 1 indicates that the match will be exact. When `exact_match_flag` is equal to 1, it is a requirement of bitstream conformance that the decoded pictures at and subsequent to the specified recovery point in output order derived by starting the decoding process at the access unit associated with the recovery point SEI message shall be an exact match to the pictures that would be produced by starting the decoding process at the location of a previous IRAP access unit, if any, in the bitstream.

NOTE 3 When performing random access, decoders are expected to infer all references to unavailable pictures as references to pictures containing only intra coding blocks and having sample values given by Y equal to $(1 \ll (\text{BitDepth}_Y - 1))$, Cb and Cr both equal to $(1 \ll (\text{BitDepth}_C - 1))$ (mid-level grey), regardless of the value of `exact_match_flag`.

When `exact_match_flag` is equal to 0, the quality of the approximation at the recovery point is chosen by the encoding process and is not specified in this document.

broken_link_flag indicates the presence or absence of a broken link in the NAL unit stream at the location of the recovery point SEI message and is assigned further semantics as follows.

- If `broken_link_flag` is equal to 1, pictures produced by starting the decoding process at the location of a previous IRAP access unit may contain undesirable visual artefacts to the extent that decoded pictures at and subsequent to the access unit associated with the recovery point SEI message in decoding order should not be displayed until the specified recovery point in output order.
- Otherwise (`broken_link_flag` is equal to 0), no indication is given regarding any potential presence of visual artefacts.

When the current picture is a BLA picture, the value of `broken_link_flag` shall be equal to 1.

Regardless of the value of the `broken_link_flag`, pictures subsequent to the specified recovery point in output order are specified to be correct or approximately correct in content.

D.3.9 Scene information SEI message semantics

A scene and a scene transition are herein defined as a set of consecutive pictures in output order.

NOTE 1 Decoded pictures within one scene generally have similar content. The scene information SEI message is used to label pictures with scene identifiers and to indicate scene changes. The message specifies how the source pictures for the labelled pictures were created. The decoder may use the information to select an appropriate algorithm to conceal transmission errors. For example, a specific algorithm may be used to conceal transmission errors that occurred in pictures belonging to a gradual scene transition. Furthermore, the scene information SEI message may be used in a manner determined by the application, such as for indexing the scenes of a video sequence.

A scene information SEI message labels all pictures of the current layer, in decoding order, from the coded picture to which the SEI message is associated (inclusive) to the coded picture to which the next scene information SEI message applicable to the current layer (when present) in decoding order is associated (exclusive) or (otherwise) to the last picture in the CLVS (inclusive). These pictures are herein referred to as the target pictures.

NOTE 2 The semantics of the scene information SEI message apply layer-wise. However, the scene information SEI message may be contained within a scalable nesting SEI message, which may help in reducing the number of scene information SEI messages, as scene changes and transitions apply across layers.

scene_info_present_flag equal to 0 indicates that the scene or scene transition to which the target pictures belong is unspecified. `scene_info_present_flag` equal to 1 indicates that the target pictures belong to the same scene or scene transition.

prev_scene_id_valid_flag equal to 0 specifies that the `scene_id` value of the picture preceding the first picture of the target pictures in output order is considered unspecified in the semantics of the syntax elements of this SEI message. `prev_scene_id_valid_flag` equal to 1 specifies that the `scene_id` value of the picture preceding the first picture of the target pictures in output order is specified by the previous scene information SEI message in decoding order. When the previous scene information SEI message applicable to the current layer is within the same CLVS as the current scene information SEI message, `prev_scene_id_valid_flag` shall be equal to 1.

NOTE 3 When a current scene information SEI message is associated with the first picture, in decoding order, of a CLVS, `prev_scene_id_valid_flag` equal to 1 indicates that the `scene_id` values of the current scene information SEI message and the previous scene information SEI message applicable to the current layer in decoding order can be used to conclude whether their target pictures belong to the same scene or to different scenes.

NOTE 4 When CVS B is concatenated to CVS A and CVS A represents a different scene than the scene CVS B represents, it should be noticed that the `scene_id` value specified for the last picture with a particular `nuh_layer_id` value of CVS A affects the semantics of the scene information SEI message associated with that particular

ISO/IEC 23008-2:2017(E)

nuh_layer_id value and the first picture, in decoding order, of CVS B, when the SEI message is present. Hence, as part of such a concatenation operation, the value of prev_scene_id_valid_flag should be set equal to 0 in the scene information SEI message associated with the first picture, in decoding order, of CVS B, when the SEI message is present.

scene_id identifies the scene to which the target pictures belong. When the value of scene_transition_type of the target pictures is less than 4, and the previous picture in output order is marked with a value of scene_transition_type less than 4, and the value of scene_id is the same as the value of scene_id of the previous picture in output order, this indicates that the source scene for the target pictures and the source scene for the previous picture (in output order) are considered by the encoder to have been the same scene. When the value of scene_transition_type of the target pictures is greater than 3, and the previous picture in output order is marked with a value of scene_transition_type less than 4, and the value of scene_id is the same as the value of scene_id of the previous picture in output order, this indicates that one of the source scenes for the target pictures and the source scene for the previous picture (in output order) are considered by the encoder to have been the same scene. When the value of scene_id is not equal to the value of scene_id of the previous picture in output order, this indicates that the target pictures and the previous picture (in output order) are considered by the encoder to have been from different source scenes.

The value of scene_id shall be in the range of 0 to $2^{32} - 2$, inclusive.

Values of scene_id in the range of 0 to 255, inclusive, and in the range of 512 to $2^{31} - 1$, inclusive, may be used as determined by the application. Values of scene_id in the range of 256 to 511, inclusive, and in the range of 2^{31} to $2^{32} - 2$, inclusive, are reserved for future use by ITU-T | ISO/IEC. Decoders encountering a value of scene_id in the range of 256 to 511, inclusive, or in the range of 2^{31} to $2^{32} - 2$, inclusive, shall ignore it.

NOTE 5 When the first picture picA, in decoding order, of the CLVS vidSeqA represents a different scene than the last picture, in output order, of the previous CLVS of the same layer and a scene information SEI message is associated with PicA, the scene_id value of that scene information SEI message should have a random value within the value ranges constrained above. Subsequent scene_id and second_scene_id values may be selected for example by incrementing the initial randomly selected scene_id value. Consequently, when concatenating vidSeqA to a CLVS vidSeqB of the same layer, accidental use of the same scene_id values in vidSeqA and vidSeqB is unlikely.

scene_transition_type specifies in which type of a scene transition (if any) the target pictures are involved. The valid values of scene_transition_type are specified in Table D.3.

Table D.3 — scene_transition_type values

Value	Description
0	No transition
1	Fade to black
2	Fade from black
3	Unspecified transition from or to constant colour
4	Dissolve
5	Wipe
6	Unspecified mixture of two scenes

When scene_transition_type is greater than 3, the target pictures include contents both from the scene labelled by its scene_id and the next scene, in output order, which is labelled by second_scene_id (see below). The term "the current scene" is used to indicate the scene labelled by scene_id. The term "the next scene" is used to indicate the scene labelled by second_scene_id. It is not required for any following picture, in output order, to be labelled with scene_id equal to second_scene_id of the current SEI message.

Scene transition types are specified as follows:

- “No transition” specifies that the target pictures are not involved in a gradual scene transition.

NOTE 6 When two consecutive pictures in output order have `scene_transition_type` equal to 0 and different values of `scene_id`, a scene cut occurred between the two pictures.

- “Fade to black” indicates that the target pictures are part of a sequence of pictures, in output order, involved in a fade to black scene transition, i.e. the luma samples of the scene gradually approach zero and the chroma samples of the scene gradually approach 128.

NOTE 7 When two pictures are labelled to belong to the same scene transition and their `scene_transition_type` is “Fade to black”, the later one, in output order, is darker than the previous one.

- “Fade from black” indicates that the target pictures are part of a sequence of pictures, in output order, involved in a fade from black scene transition, i.e. the luma samples of the scene gradually diverge from zero and the chroma samples of the scene may gradually diverge from 128.

NOTE 8 When two pictures are labelled to belong to the same scene transition and their `scene_transition_type` is “Fade from black”, the later one in output order is lighter than the previous one.

- “Dissolve” indicates that the sample values of each target picture (before encoding) were generated by calculating a sum of co-located weighted sample values of a picture from the current scene and a picture from the next scene. The weight of the current scene gradually decreases from full level to zero level, whereas the weight of the next scene gradually increases from zero level to full level. When two pictures are labelled to belong to the same scene transition and their `scene_transition_type` is “Dissolve”, the weight of the current scene for the later one, in output order, is less than the weight of the current scene for the previous one, and the weight of the next scene for the later one, in output order, is greater than the weight of the next scene for the previous one.
- “Wipe” indicates that some of the sample values of each target picture (before encoding) were generated by copying co-located sample values of a picture in the current scene and the remaining sample values of each target picture (before encoding) were generated by copying co-located sample values of a picture in the next scene. When two pictures are labelled to belong to the same scene transition and their `scene_transition_type` is “Wipe”, the number of samples copied from the next scene to the later picture in output order is greater than the number of samples copied from the next scene to the previous picture.

second_scene_id identifies the next scene in the gradual scene transition in which the target pictures are involved. The value of `second_scene_id` shall not be equal to the value of `scene_id`. The value of `second_scene_id` shall not be equal to the value of `scene_id` in the previous picture in output order. When the next picture in output order is marked with a value of `scene_transition_type` less than 4, and the value of `second_scene_id` is the same as the value of `scene_id` of the next picture in output order, this indicates that the encoder considers one of the source scenes for the target pictures and the source scene for the next picture (in output order) to have been the same scene. When the value of `second_scene_id` is not equal to the value of `scene_id` or `second_scene_id` (when present) of the next picture in output order, this indicates that the encoder considers the target pictures and the next picture (in output order) to have been from different source scenes.

When the value of `scene_id` of a picture is equal to the value of `scene_id` of the following picture in output order and the value of `scene_transition_type` in both of these pictures is less than 4, this indicates that the encoder considers the two pictures to have been from the same source scene. When the values of `scene_id`, `scene_transition_type` and `second_scene_id` (when present) of a picture are equal to the values of `scene_id`, `scene_transition_type` and `second_scene_id` (respectively) of the following picture in output order and the value of `scene_transition_type` is greater than 0, this indicates that the encoder considers the two pictures to have been from the same source gradual scene transition.

ISO/IEC 23008-2:2017(E)

The value of `second_scene_id` shall be in the range of 0 to $2^{32} - 2$, inclusive.

Values of `second_scene_id` in the range of 0 to 255, inclusive, and in the range of 512 to $2^{31} - 1$, inclusive, may be used as determined by the application. Values of `second_scene_id` in the range of 256 to 511, inclusive, and in the range of 2^{31} to $2^{32} - 2$, inclusive, are reserved for future use by ITU-T | ISO/IEC. Decoders encountering a value of `second_scene_id` in the range of 256 to 511, inclusive, or in the range of 2^{31} to $2^{32} - 2$, inclusive, shall ignore it.

D.3.10 Picture snapshot SEI message semantics

The picture snapshot SEI message indicates that the current picture is labelled for use as determined by the application as a still-image snapshot of the video content.

snapshot_id specifies a snapshot identification number. `snapshot_id` shall be in the range of 0 to $2^{32} - 2$, inclusive.

Values of `snapshot_id` in the range of 0 to 255, inclusive, and in the range of 512 to $2^{31} - 1$, inclusive, may be used as determined by the application. Values of `snapshot_id` in the range of 256 to 511, inclusive, and in the range of 2^{31} to $2^{32} - 2$, inclusive, are reserved for future use by ITU-T | ISO/IEC. Decoders encountering a value of `snapshot_id` in the range of 256 to 511, inclusive, or in the range of 2^{31} to $2^{32} - 2$, inclusive, shall ignore it.

D.3.11 Progressive refinement segment start SEI message semantics

The progressive refinement segment start SEI message specifies the beginning of a set of consecutive coded pictures in the current layer in decoding order that consists of the current picture and a sequence of one or more subsequent pictures in the current layer that refine the quality of the current picture, rather than a representation of a continually moving scene.

Let `picA` be the current picture. The tagged set of consecutive coded pictures `refinementPicSet` in the current layer consists of, in decoding order, the next picture in the current layer after the current picture in decoding order, when present, followed by zero or more pictures in the current layer, including all subsequent pictures in the current layer up to but not including any subsequent picture `picB` in the current layer for which one of the following conditions is true:

- The picture `picB` starts a new CLVS of the current layer.
- The value of `pic_order_cnt_delta` is greater than 0 and the `PicOrderCntVal` of the picture `picB`, i.e. `PicOrderCnt(picB)` is greater than `PicOrderCnt(picA) + pic_order_cnt_delta`, where `PicOrderCnt(picB)` and `PicOrderCnt(picA)` are the `PicOrderCntVal` values of `picB` and `picA`, respectively, immediately after the invocation of the decoding process for picture order count for `picB`.
- The picture `picB` is associated with a progressive refinement segment end SEI message that has the same `progressive_refinement_id` as the one in this SEI message and also applies to the current layer is decoded.

The decoding order of pictures within `refinementPicSet` should be the same as their output order.

progressive_refinement_id specifies an identification number for the progressive refinement operation. `progressive_refinement_id` shall be in the range of 0 to $2^{32} - 2$, inclusive.

Values of `progressive_refinement_id` in the range of 0 to 255, inclusive, and in the range of 512 to $2^{31} - 1$, inclusive, may be used as determined by the application. Values of `progressive_refinement_id` in the range of 256 to 511, inclusive, and in the range of 2^{31} to $2^{32} - 2$, inclusive, are reserved for future use by ITU-T | ISO/IEC. Decoders encountering a value of `progressive_refinement_id` in the range of 256 to 511, inclusive, or in the range of 2^{31} to $2^{32} - 2$, inclusive, shall ignore it.

pic_order_cnt_delta specifies the last picture in refinementPicSet in decoding order as follows:

- If **pic_order_cnt_delta** is equal to 0, the last picture in refinementPicSet in decoding order is the following picture:
 - If the CLVS contains one or more pictures in the current layer that follow the current picture in decoding order and are associated with a progressive refinement segment end SEI message that has the same **progressive_refinement_id** and also applies to the current layer, the last picture in refinementPicSet in decoding order is the first of these pictures in decoding order.
 - Otherwise, the last picture in refinementPicSet in decoding order is the last picture in the current layer within the CLVS in decoding order.
- Otherwise, the last picture in refinementPicSet in decoding order is the following picture:
 - If the CLVS contains one or more pictures in the current layer that follow the current picture in decoding order, that are associated with a progressive refinement segment end SEI message with the same **progressive_refinement_id** and applicable to the current layer, and that precede any picture **picC** in the current layer in the CLVS for which $\text{PicOrderCnt}(\text{picC})$ is greater than $\text{PicOrderCnt}(\text{picA}) + \text{pic_order_cnt_delta}$, where $\text{PicOrderCnt}(\text{picC})$ and $\text{PicOrderCnt}(\text{picA})$ are the PicOrderCntVal of the **picC** and **picA**, respectively, immediately after the invocation of the decoding process for picture order count for **picC**, the last picture in refinementPicSet in decoding order is the first of these pictures in decoding order.
 - Otherwise, if the CLVS contains one or more pictures **picD** in the current layer that follow the current picture in decoding order for which $\text{PicOrderCnt}(\text{picD})$ is greater than $\text{PicOrderCnt}(\text{picA}) + \text{pic_order_cnt_delta}$, where $\text{PicOrderCnt}(\text{picD})$ and $\text{PicOrderCnt}(\text{picA})$ are the PicOrderCntVal values of **picD** and **picA**, respectively, immediately after the invocation of the decoding process for picture order count for **picD**, the last picture in refinementPicSet in decoding order is the last picture in the current layer that precedes the first of these pictures in decoding order.
 - Otherwise, the last picture in refinementPicSet in decoding order is the last picture in the current layer within the CLVS in decoding order.

The value of **pic_order_cnt_delta** shall be in the range of 0 to 256, inclusive.

D.3.12 Progressive refinement segment end SEI message semantics

The progressive refinement segment end SEI message specifies the end of a set of consecutive coded pictures that has been labelled by use of a progressive refinement segment start SEI message as an initial picture followed by a sequence of one or more pictures of the refinement of the quality of the initial picture, and ending with the current picture.

progressive_refinement_id specifies an identification number for the progressive refinement operation. **progressive_refinement_id** shall be in the range of 0 to $2^{32} - 2$, inclusive.

The progressive refinement segment end SEI message specifies the end of any progressive refinement segment previously started using a progressive refinement segment start SEI message with the same value of **progressive_refinement_id**.

Values of **progressive_refinement_id** in the range of 0 to 255, inclusive, and in the range of 512 to $2^{31} - 1$, inclusive, may be used as determined by the application. Values of **progressive_refinement_id** in the range of 256 to 511, inclusive, and in the range of 2^{31} to $2^{32} - 2$, inclusive, are reserved for future use by ITU-T | ISO/IEC. Decoders encountering a value of **progressive_refinement_id** in the range of 256 to 511, inclusive, or in the range of 2^{31} to $2^{32} - 2$, inclusive, shall ignore it.

D.3.13 Film grain characteristics SEI message semantics

This SEI message provides the decoder with a parameterized model for film grain synthesis.

NOTE 1 For example, an encoder may use the film grain characteristics SEI message to characterize film grain that was present in the original source video material and was removed by pre-processing filtering techniques. Synthesis of simulated film grain on the decoded images for the display process is optional and does not affect the decoding process specified in this document. When synthesis of simulated film grain on the decoded images for the display process is performed, there is no requirement that the method by which the synthesis is performed be the same as the parameterized model for the film grain as provided in the film grain characteristics SEI message.

NOTE 2 The display process is not specified in this document.

NOTE 3 Society of Motion Picture and Television Engineers RDD 5 specifies a film grain simulator based on the information provided in the film grain characteristics SEI message.

film_grain_characteristics_cancel_flag equal to 1 indicates that the SEI message cancels the persistence of any previous film grain characteristics SEI message in output order that applies to the current layer. **film_grain_characteristics_cancel_flag** equal to 0 indicates that film grain modelling information follows.

film_grain_model_id identifies the film grain simulation model as specified in Table D.4. The value of **film_grain_model_id** shall be in the range of 0 to 1, inclusive. The values of 2 and 3 for **film_grain_model_id** are reserved for future use by ITU-T | ISO/IEC and shall not be present in bitstreams conforming to this version of this document. Decoders shall ignore film grain characteristic SEI messages with **film_grain_model_id** equal to 2 or 3.

Table D.4 — film_grain_model_id values

Value	Description
0	Frequency filtering
1	Auto-regression

separate_colour_description_present_flag equal to 1 indicates that a distinct colour space description for the film grain characteristics specified in the SEI message is present in the film grain characteristics SEI message syntax. **separate_colour_description_present_flag** equal to 0 indicates that the colour description for the film grain characteristics specified in the SEI message is the same as for the CVS as specified in E.3.1.

NOTE 4 When **separate_colour_description_present_flag** is equal to 1, the colour space specified for the film grain characteristics specified in the SEI message may differ from the colour space specified for the coded video as specified in E.3.1.

film_grain_bit_depth_luma_minus8 plus 8 specifies the bit depth used for the luma component of the film grain characteristics specified in the SEI message. When **film_grain_bit_depth_luma_minus8** is not present in the film grain characteristics SEI message, the value of **film_grain_bit_depth_luma_minus8** is inferred to be equal to **bit_depth_luma_minus8**.

The value of **filmGrainBitDepth[0]** is derived as follows:

$$\text{filmGrainBitDepth}[0] = \text{film_grain_bit_depth_luma_minus8} + 8 \tag{D-3}$$

film_grain_bit_depth_chroma_minus8 plus 8 specifies the bit depth used for the Cb and Cr components of the film grain characteristics specified in the SEI message. When **film_grain_bit_depth_chroma_minus8** is not present in the film grain characteristics SEI message, the value of **film_grain_bit_depth_chroma_minus8** is inferred to be equal to **bit_depth_chroma_minus8**.

The value of `filmGrainBitDepth[c]` for `c = 1` and `2` is derived as follows:

$$\text{filmGrainBitDepth}[c] = \text{film_grain_bit_depth_chroma_minus8} + 8, \text{ with } c = 1, 2 \quad (\text{D-4})$$

film_grain_full_range_flag has the same semantics as specified in E.3.1 for the `video_full_range_flag` syntax element, except as follows:

- `film_grain_full_range_flag` specifies the colour space of the film grain characteristics specified in the SEI message, rather than the colour space used for the CVS.
- When `film_grain_full_range_flag` is not present in the film grain characteristics SEI message, the value of `film_grain_full_range_flag` is inferred to be equal to `video_full_range_flag`.

film_grain_colour_primaries has the same semantics as specified in E.3.1 for the colour primaries syntax element, except as follows:

- `film_grain_colour_primaries` specifies the colour space of the film grain characteristics specified in the SEI message, rather than the colour space used for the CVS.
- When `film_grain_colour_primaries` is not present in the film grain characteristics SEI message, the value of `film_grain_colour_primaries` is inferred to be equal to `colour_primaries`.

film_grain_transfer_characteristics has the same semantics as specified in E.3.1 for the `transfer_characteristics` syntax element, except as follows:

- `film_grain_transfer_characteristics` specifies the colour space of the film grain characteristics specified in the SEI message, rather than the colour space used for the CVS.
- When `film_grain_transfer_characteristics` is not present in the film grain characteristics SEI message, the value of `film_grain_transfer_characteristics` is inferred to be equal to `transfer_characteristics`.

film_grain_matrix_coeffs has the same semantics as specified in E.3.1 for the `matrix_coeffs` syntax element, except as follows:

- `film_grain_matrix_coeffs` specifies the colour space of the film grain characteristics specified in the SEI message, rather than the colour space used for the CVS.
- When `film_grain_matrix_coeffs` is not present in the film grain characteristics SEI message, the value of `film_grain_matrix_coeffs` is inferred to be equal to `matrix_coeffs`.
- The values allowed for `film_grain_matrix_coeffs` are not constrained by the value of `chroma_format_idc`.

The `chroma_format_idc` of the film grain characteristics specified in the film grain characteristics SEI message is inferred to be equal to 3 (4:4:4).

NOTE 5 Because the use of a specific method is not required for performing film grain generation function used by the display process, a decoder may, if desired, down-convert the model information for chroma in order to simulate film grain for other chroma formats (4:2:0 or 4:2:2) rather than up-converting the decoded video (using a method not specified in this document) before performing film grain generation.

blending_mode_id identifies the blending mode used to blend the simulated film grain with the decoded images as specified in Table D.5. `blending_mode_id` shall be in the range of 0 to 1, inclusive. The values of 2 and 3 for `blending_mode_id` are reserved for future use by ITU-T | ISO/IEC and shall not be present in bitstreams conforming to this version of this document. Decoders shall ignore film grain characteristic SEI messages with `blending_mode_id` equal to 2 or 3.

Table D.5 — blending_mode_id values

Value	Description
0	Additive
1	Multiplicative

Depending on the value of `blending_mode_id`, the blending mode is specified as follows:

- If `blending_mode_id` is equal to 0, the blending mode is additive as specified by:

$$I_{\text{grain}}[x, y, c] = \text{Clip3}(0, (1 \ll \text{filmGrainBitDepth}[c]) - 1, I_{\text{decoded}}[x, y, c] + G[x, y, c]) \quad (\text{D-5})$$

- Otherwise (`blending_mode_id` is equal to 1), the blending mode is multiplicative as specified by:

$$I_{\text{grain}}[x, y, c] = \text{Clip3}(0, (1 \ll \text{filmGrainBitDepth}[c]) - 1, I_{\text{decoded}}[x, y, c] + \text{Round}((I_{\text{decoded}}[x, y, c] * G[x, y, c]) \div ((1 \ll \text{bitDepth}[c]) - 1))) \quad (\text{D-6})$$

where $I_{\text{decoded}}[x, y, c]$ represents the sample value at coordinates x, y of the colour component c of the decoded image I_{decoded} , $G[x, y, c]$ is the simulated film grain value at the same position and colour component, $\text{filmGrainBitDepth}[c]$ is the number of bits used for each sample in a fixed-length unsigned binary representation of the array $I_{\text{grain}}[x, y, c]$, and $\text{bitDepth}[c]$ is specified by:

$$\text{bitDepth}[c] = \begin{cases} \text{BitDepth}_Y & ; c = 0 \\ \text{BitDepth}_C & ; c = 1, 2 \end{cases} \quad (\text{D-7})$$

log2_scale_factor specifies a scale factor used in the film grain characterization equations.

comp_model_present_flag[c] equal to 0 indicates that film grain is not modelled on the c -th colour component, where c equal to 0 refers to the luma component, c equal to 1 refers to the Cb component, and c equal to 2 refers to the Cr component. **comp_model_present_flag**[c] equal to 1 indicates that syntax elements specifying modelling of film grain on colour component c are present in the SEI message.

num_intensity_intervals_minus1[c] plus 1 specifies the number of intensity intervals for which a specific set of model values has been estimated.

NOTE 6 The intensity intervals may overlap in order to simulate multi-generational film grain.

num_model_values_minus1[c] plus 1 specifies the number of model values present for each intensity interval in which the film grain has been modelled. The value of **num_model_values_minus1**[c] shall be in the range of 0 to 5, inclusive.

intensity_interval_lower_bound[c][i] specifies the lower bound of the interval i of intensity levels for which the set of model values applies.

intensity_interval_upper_bound[c][i] specifies the upper bound of the interval i of intensity levels for which the set of model values applies.

Depending on the value of `film_grain_model_id`, the selection of the sets of model values is specified as follows:

- If `film_grain_model_id` is equal to 0, the average value of each block b of 8×8 samples in I_{decoded} , referred as b_{avg} , is used to select the sets of model values with index $s[j]$ that apply to all the samples in the block:

```

for( i = 0, j = 0; i <= num_intensity_intervals_minus1[ c ]; i++ )
  if( bavg >= intensity_interval_lower_bound[ c ][ i ]
      && bavg <= intensity_interval_upper_bound[ c ][ i ] ) {
    s[ j ] = i
    j++
  }

```

(D-8)

- Otherwise (film_grain_model_id is equal to 1), the sets of model values used to generate the film grain are selected for each sample value in I_{decoded} as follows:

```

for( i = 0, j = 0; i <= num_intensity_intervals_minus1[ c ]; i++ )
  if( Idecoded[ x, y, c ] >= intensity_interval_lower_bound[ c ][ i ] &&
      Idecoded[ x, y, c ] <= intensity_interval_upper_bound[ c ][ i ] ) {
    s[ j ] = i
    j++
  }

```

(D-9)

Samples that do not fall into any of the defined intervals are not modified by the grain generation function. Samples that fall into more than one interval will originate multi-generation grain. Multi-generation grain results from adding the grain computed independently for each intensity interval.

comp_model_value[c][i][j] represents each one of the model values present for the colour component c and the intensity interval i . The set of model values has different meaning depending on the value of film_grain_model_id.

The value of comp_model_value[c][i][j] is constrained as follows, and may be additionally constrained as specified elsewhere in this clause:

- If film_grain_model_id is equal to 0, comp_model_value[c][i][j] shall be in the range of 0 to $2^{\text{filmGrainBitDepth}[c]} - 1$, inclusive.
- Otherwise (film_grain_model_id is equal to 1), comp_model_value[c][i][j] shall be in the range of $-2^{(\text{filmGrainBitDepth}[c] - 1)}$ to $2^{(\text{filmGrainBitDepth}[c] - 1)} - 1$, inclusive.

Depending on the value of film_grain_model_id, the synthesis of the film grain is modelled as follows:

- If film_grain_model_id is equal to 0, a frequency filtering model enables simulating the original film grain for $c = 0..2$, $x = 0..pic_width_in_luma_samples$, and $y = 0..pic_height_in_luma_samples$ as specified by:

$$G[x, y, c] = (\text{comp_model_value}[c][s][0] * Q[c][x, y] + \text{comp_model_value}[c][s][5] * G[x, y, c - 1]) \gg \log_2_scale_factor \quad (\text{D-10})$$

where $Q[c]$ is a two-dimensional random process generated by filtering 16x16 blocks gaussRv with random-value elements gaussRv_{ij} generated with a normalized Gaussian distribution (independent and identically distributed Gaussian random variable samples with zero mean and unity variance) and where the value of an element $G[x, y, c - 1]$ used in the right-hand side of the equation is inferred to be equal to 0 when $c - 1$ is less than 0.

NOTE 7 A normalized Gaussian random value can be generated from two independent, uniformly distributed random values over the interval from 0 to 1 (and not equal to 0), denoted as uRv₀ and uRv₁, using the Box-Muller transformation specified by:

$$\text{gaussRv}_{ij} = \sqrt{-2 * \text{Ln}(\text{uRv}_0)} * \text{Cos}(2 * \pi * \text{uRv}_1) \quad (\text{D-11})$$

where π is Archimedes' constant 3.141 592 653 589 793....

ISO/IEC 23008-2:2017(E)

The band-pass filtering of blocks `gaussRv` may be performed in the discrete cosine transform (DCT) domain as follows:

```

for( y = 0; y < 16; y++ )
  for( x = 0; x < 16; x++ )
    if( ( x < comp_model_value[ c ][ s ][ 3 ] && y < comp_model_value[ c ][ s ][ 4 ] ) ||
        x > comp_model_value[ c ][ s ][ 1 ] || y > comp_model_value[ c ][ s ][ 2 ] )
      gaussRv[ x, y ] = 0
    filteredRv = IDCT16x16( gaussRv )

```

(D-12)

where `IDCT16x16(z)` refers to a unitary inverse discrete cosine transformation (IDCT) operating on a 16x16 matrix argument `z` as specified by:

$$\text{IDCT}_{16 \times 16}(z) = r * z * r^T \quad (\text{D-13})$$

where the superscript `T` indicates a matrix transposition and `r` is the 16x16 matrix with elements `rij` specified by:

$$r_{ij} = \frac{((i = 0) ? 1 : \sqrt{2})}{4} \text{Cos} \left(\frac{i * (2 * j + 1) * \pi}{32} \right) \quad (\text{D-14})$$

where π is Archimedes' constant 3.141 592 653 589 793....

`Q[c]` is formed by the frequency-filtered blocks `filteredRv`.

NOTE 8 Coded model values are based on blocks of 16x16, but a decoder implementation can use other block sizes. For example, decoders implementing the IDCT on 8x8 blocks are expected to down-convert by a factor of two the set of coded model values `comp_model_value[c][s][i]` for `i` equal to 1..4.

NOTE 9 To reduce the degree of visible blocks that can result from mosaicking the frequency-filtered blocks `filteredRv`, decoders may apply a low-pass filter to the boundaries between frequency-filtered blocks.

— Otherwise (`film_grain_model_id` is equal to 1), an auto-regression model enables simulating the original film grain for `c = 0..2`, `x = 0..pic_width_in_luma_samples`, and `y = 0..pic_height_in_luma_samples` as specified by:

$$\begin{aligned}
 G[x, y, c] = & (\text{comp_model_value}[c][s][0] * n[x, y, c] + \\
 & \text{comp_model_value}[c][s][1] * (G[x - 1, y, c] + ((\text{comp_model_value}[c][s][4] * G[x, y - 1, \\
 & c]) >> \\
 & \log_2_scale_factor)) + \\
 & \text{comp_model_value}[c][s][3] * (((\text{comp_model_value}[c][s][4] * G[x - 1, y - 1, c]) >> \\
 & \log_2_scale_factor) + G[x + 1, y - 1, c]) + \\
 & \text{comp_model_value}[c][s][5] * (G[x - 2, y, c] + \\
 & ((\text{comp_model_value}[c][s][4] * \text{comp_model_value}[c][s][4] * G[x, y - 2, c]) >> \\
 & (2 * \log_2_scale_factor))) + \\
 & \text{comp_model_value}[c][s][2] * G[x, y, c - 1]) >> \log_2_scale_factor
 \end{aligned}
 \quad (\text{D-15})$$

where `n[x, y, c]` is a random value with normalized Gaussian distribution (independent and identically distributed Gaussian random variable samples with zero mean and unity variance for each value of `x`, `y`, and `c`) and where the value of an element `G[x, y, c]` used in the right-hand side of the equation is inferred to be equal to 0 when any of the following conditions are true:

- `x` is less than 0;
- `y` is less than 0;
- `c` is less than 0.

$\text{comp_model_value}[c][i][0]$ provides the first model value for the model as specified by $\text{film_grain_model_id}$. $\text{comp_model_value}[c][i][0]$ corresponds to the standard deviation of the Gaussian noise term in the generation functions specified in Formulae (D-10) through (D-15).

$\text{comp_model_value}[c][i][1]$ provides the second model value for the model as specified by $\text{film_grain_model_id}$. When $\text{film_grain_model_id}$ is equal to 0, $\text{comp_model_value}[c][i][1]$ shall be greater than or equal to 0 and less than 16.

When not present in the film grain characteristics SEI message, $\text{comp_model_value}[c][i][1]$ is inferred as follows:

- If $\text{film_grain_model_id}$ is equal to 0, $\text{comp_model_value}[c][i][1]$ is inferred to be equal to 8.
- Otherwise ($\text{film_grain_model_id}$ is equal to 1), $\text{comp_model_value}[c][i][1]$ is inferred to be equal to 0.

$\text{comp_model_value}[c][i][1]$ is interpreted as follows:

- If $\text{film_grain_model_id}$ is equal to 0, $\text{comp_model_value}[c][i][1]$ indicates the horizontal high cut frequency to be used to filter the DCT of a block of 16x16 random values.
- Otherwise ($\text{film_grain_model_id}$ is equal to 1), $\text{comp_model_value}[c][i][1]$ indicates the first order spatial correlation for neighbouring samples $(x - 1, y)$ and $(x, y - 1)$.

$\text{comp_model_value}[c][i][2]$ provides the third model value for the model as specified by $\text{film_grain_model_id}$. When $\text{film_grain_model_id}$ is equal to 0, $\text{comp_model_value}[c][i][2]$ shall be greater than or equal to 0 and less than 16.

When not present in the film grain characteristics SEI message, $\text{comp_model_value}[c][i][2]$ is inferred as follows:

- If $\text{film_grain_model_id}$ is equal to 0, $\text{comp_model_value}[c][i][2]$ is inferred to be equal to $\text{comp_model_value}[c][i][1]$.
- Otherwise ($\text{film_grain_model_id}$ is equal to 1), $\text{comp_model_value}[c][i][2]$ is inferred to be equal to 0.

$\text{comp_model_value}[c][i][2]$ is interpreted as follows:

- If $\text{film_grain_model_id}$ is equal to 0, $\text{comp_model_value}[c][i][2]$ indicates the vertical high cut frequency to be used to filter the DCT of a block of 16x16 random values.
- Otherwise ($\text{film_grain_model_id}$ is equal to 1), $\text{comp_model_value}[c][i][2]$ indicates the colour correlation between consecutive colour components.

$\text{comp_model_value}[c][i][3]$ provides the fourth model value for the model as specified by $\text{film_grain_model_id}$. When $\text{film_grain_model_id}$ is equal to 0, $\text{comp_model_value}[c][i][3]$ shall be greater than or equal to 0 and less than or equal to $\text{comp_model_value}[c][i][1]$.

When not present in the film grain characteristics SEI message, $\text{comp_model_value}[c][i][3]$ is inferred to be equal to 0.

$\text{comp_model_value}[c][i][3]$ is interpreted as follows:

- If $\text{film_grain_model_id}$ is equal to 0, $\text{comp_model_value}[c][i][3]$ indicates the horizontal low cut frequency to be used to filter the DCT of a block of 16x16 random values.
- Otherwise ($\text{film_grain_model_id}$ is equal to 1), $\text{comp_model_value}[c][i][3]$ indicates the first order spatial correlation for neighbouring samples $(x - 1, y - 1)$ and $(x + 1, y - 1)$.

ISO/IEC 23008-2:2017(E)

`comp_model_value[c][i][4]` provides the fifth model value for the model as specified by `film_grain_model_id`. When `film_grain_model_id` is equal to 0, `comp_model_value[c][i][4]` shall be greater than or equal to 0 and less than or equal to `comp_model_value[c][i][2]`.

When not present in the film grain characteristics SEI message, `comp_model_value[c][i][4]` is inferred to be equal to `film_grain_model_id`.

`comp_model_value[c][i][4]` is interpreted as follows:

- If `film_grain_model_id` is equal to 0, `comp_model_value[c][i][4]` indicates the vertical low cut frequency to be used to filter the DCT of a block of 16x16 random values.
- Otherwise (`film_grain_model_id` is equal to 1), `comp_model_value[c][i][4]` indicates the aspect ratio of the modelled grain.

`comp_model_value[c][i][5]` provides the sixth model value for the model as specified by `film_grain_model_id`.

When not present in the film grain characteristics SEI message, `comp_model_value[c][i][5]` is inferred to be equal to 0.

`comp_model_value[c][i][5]` is interpreted as follows:

- If `film_grain_model_id` is equal to 0, `comp_model_value[c][i][5]` indicates the colour correlation between consecutive colour components.
- Otherwise (`film_grain_model_id` is equal to 1), `comp_model_value[c][i][5]` indicates the second order spatial correlation for neighbouring samples $(x, y - 2)$ and $(x - 2, y)$.

film_grain_characteristics_persistence_flag specifies the persistence of the film grain characteristics SEI message for the current layer.

`film_grain_characteristics_persistence_flag` equal to 0 specifies that the film grain characteristics SEI message applies to the current decoded picture only.

Let `picA` be the current picture. `film_grain_characteristics_persistence_flag` equal to 1 specifies that the film grain characteristics SEI message persists for the current layer in output order until any of the following conditions are true:

- A new CLVS of the current layer begins.
- The bitstream ends.
- A picture `picB` in the current layer in an access unit containing a film grain characteristics SEI message that is applicable to the current layer is output for which `PicOrderCnt(picB)` is greater than `PicOrderCnt(picA)`, where `PicOrderCnt(picB)` and `PicOrderCnt(picA)` are the `PicOrderCntVal` values of `picB` and `picA`, respectively, immediately after the invocation of the decoding process for picture order count for `picB`.

D.3.14 Post-filter hint SEI message semantics

This SEI message provides the coefficients of a post-filter or correlation information for the design of a post-filter for potential use in post-processing of the current picture after it is decoded and output to obtain improved displayed quality.

filter_hint_size_y specifies the vertical size of the filter coefficient or correlation array. The value of `filter_hint_size_y` shall be in the range of 1 to 15, inclusive.

filter_hint_size_x specifies the horizontal size of the filter coefficient or correlation array. The value of `filter_hint_size_x` shall be in the range of 1 to 15, inclusive.

filter_hint_type identifies the type of the transmitted filter hints as specified in Table D.6. The value of filter_hint_type shall be in the range of 0 to 2, inclusive. The value of filter_hint_type equal to 3 is reserved for future use by ITU-T | ISO/IEC and shall not be present in bitstreams conforming to this version of this document. Decoders shall ignore post-filter hint SEI messages having filter_hint_type equal to 3.

Table D.6 — filter_hint_type values

Value	Description
0	Coefficients of a 2D-FIR filter
1	Coefficients of two 1D-FIR filters
2	Cross-correlation matrix

filter_hint_value[cIdx][cy][cx] specifies a filter coefficient or an element of a cross-correlation matrix between the original and the decoded signal with 16-bit precision. The value of filter_hint_value[cIdx][cy][cx] shall be in the range of $-2^{31} + 1$ to $2^{31} - 1$, inclusive. cIdx specifies the related colour component, cy represents a counter in vertical direction, and cx represents a counter in horizontal direction. Depending on the value of filter_hint_type, the following apply:

- If filter_hint_type is equal to 0, the coefficients of a 2-dimensional FIR filter with the size of filter_hint_size_y * filter_hint_size_x are transmitted.
- Otherwise, if filter_hint_type is equal to 1, the filter coefficients of two 1-dimensional FIR filters are transmitted. In this case, filter_hint_size_y shall be equal to 2. The index cy equal to 0 specifies the filter coefficients of the horizontal filter and cy equal to 1 specifies the filter coefficients of the vertical filter. In the filtering process, the horizontal filter is applied first and the result is filtered by the vertical filter.
- Otherwise (filter_hint_type is equal to 2), the transmitted hints specify a cross-correlation matrix between the original signal s and the decoded signal s'.

NOTE 1 The normalized cross-correlation matrix for a related colour component identified by cIdx with the size of filter_hint_size_y * filter_hint_size_x is defined as follows:

$$\text{filter_hint_value}(cIdx, cy, cx) = \frac{1}{(2^{8+\text{bitDepth}} - 1)^2 * h * w} \sum_{m=0}^{h-1} \sum_{n=0}^{w-1} s(m, n) * s'(m + cy - \text{OffsetY}, n + cx - \text{OffsetX}) \quad (\text{D-16})$$

where s denotes array of samples of the colour component cIdx of the original picture, s' denotes corresponding array of the decoded picture, h denotes the vertical height of the related colour component, w denotes the horizontal width of the related colour component, bitDepth denotes the bit depth of the colour component, OffsetY is equal to (filter_hint_size_y >> 1), OffsetX is equal to (filter_hint_size_x >> 1), $0 \leq cy < \text{filter_hint_size_y}$ and $0 \leq cx < \text{filter_hint_size_x}$.

NOTE 2 A decoder can derive a Wiener post-filter from the cross-correlation matrix of original and decoded signal and the auto-correlation matrix of the decoded signal.

D.3.15 Tone mapping information SEI message semantics

This SEI message provides information to enable remapping of the colour samples of the output decoded pictures for customization to particular display environments. The remapping process maps coded sample values in the RGB colour space (specified in Annex E) to target sample values. The mappings are expressed either in the luma or RGB colour space domain, and should be applied to the luma component or to each RGB component produced by colour space conversion of the decoded image accordingly.

tone_map_id contains an identifying number that may be used to identify the purpose of the tone mapping model. The value of tone_map_id shall be in the range of 0 to $2^{32} - 2$, inclusive.

ISO/IEC 23008-2:2017(E)

Values of `tone_map_id` from 0 to 255 and from 512 to $2^{31} - 1$ may be used as determined by the application. Values of `tone_map_id` from 256 to 511, inclusive, and from 2^{31} to $2^{32} - 2$, inclusive, are reserved for future use by ITU-T | ISO/IEC. Decoders shall ignore all tone mapping information SEI messages containing a value of `tone_map_id` in the range of 256 to 511, inclusive, or in the range of 2^{31} to $2^{32} - 2$, inclusive, and bitstreams shall not contain such values.

NOTE 1 The `tone_map_id` can be used to support tone mapping operations that are suitable for different display scenarios. For example, different values of `tone_map_id` may correspond to different display bit depths.

tone_map_cancel_flag equal to 1 indicates that the tone mapping information SEI message cancels the persistence of any previous tone mapping information SEI message in output order that applies to the current layer. `tone_map_cancel_flag` equal to 0 indicates that tone mapping information follows.

tone_map_persistence_flag specifies the persistence of the tone mapping information SEI message.

`tone_map_persistence_flag` equal to 0 specifies that the tone mapping information applies to the current decoded picture only.

Let `picA` be the current picture. `tone_map_persistence_flag` equal to 1 specifies that the tone mapping information persists for the current layer in output order until any of the following conditions are true:

- A new CLVS of the current layer begins.
- A picture `picB` in the current layer in an access unit containing a tone mapping information SEI message with the same value of `tone_map_id` and applicable to the current layer is output for which `PicOrderCnt(picB)` is greater than `PicOrderCnt(picA)`, where `PicOrderCnt(picB)` and `PicOrderCnt(picA)` are the `PicOrderCntVal` values of `picB` and `picA`, respectively, immediately after the invocation of the decoding process for picture order count for `picB`.

coded_data_bit_depth specifies the `BitDepthY` for interpretation of the luma component of the associated pictures for purposes of interpretation of the tone mapping information SEI message. When tone mapping information SEI messages are present that have `coded_data_bit_depth` that is not equal to `BitDepthY`, these refer to the hypothetical result of a transcoding operation performed to convert the coded video to the `BitDepthY` corresponding to the value of `coded_data_bit_depth`.

The value of `coded_data_bit_depth` shall be in the range of 8 to 14, inclusive. Values of `coded_data_bit_depth` from 0 to 7 and from 15 to 255 are reserved for future use by ITU-T | ISO/IEC. Decoders shall ignore all tone mapping SEI messages that contain a `coded_data_bit_depth` in the range of 0 to 7, inclusive, or in the range of 15 to 255, inclusive, and bitstreams shall not contain such values.

target_bit_depth specifies the bit depth of the output of the dynamic range mapping function (or tone mapping function) described by the tone mapping information SEI message. The tone mapping function specified with a particular `target_bit_depth` is suggested to be reasonable for all display bit depths that are less than or equal to the `target_bit_depth`.

The value of `target_bit_depth` shall be in the range of 1 to 16, inclusive. Values of `target_bit_depth` equal to 0 and in the range of 17 to 255, inclusive, are reserved for future use by ITU-T | ISO/IEC. Decoders shall ignore all tone mapping SEI messages that contain a value of `target_bit_depth` equal to 0 or in the range of 17 to 255, inclusive, and bitstreams shall not contain such values.

tone_map_model_id specifies the model utilized for mapping the coded data into the `target_bit_depth` range. Values greater than 4 are reserved for future use by ITU-T | ISO/IEC and shall not be present in bitstreams conforming to this version of this document. Decoders shall ignore all tone mapping SEI messages that contain a value of `tone_map_model_id` greater than 4, and bitstreams shall not contain such values.

NOTE 2 A `tone_map_model_id` of 0 corresponds to a linear mapping with clipping; a `tone_map_model_id` of 1 corresponds to a sigmoidal mapping; a `tone_map_model_id` of 2 corresponds to a user-defined table mapping, and a `tone_map_model_id` of 3 corresponds to a piece-wise linear mapping, `tone_map_model_id` of 4 corresponds to luminance dynamic range information.

min_value specifies the RGB sample value that maps to the minimum value in the bit depth indicated by `target_bit_depth`. It is used in combination with the `max_value` parameter. All sample values in the decoded picture that are less than or equal to `min_value`, after conversion to RGB as necessary, are mapped to this minimum value in the `target_bit_depth` representation.

max_value specifies the RGB sample value that maps to the maximum value in the bit depth indicated by `target_bit_depth`. It is used in combination with the `min_value` parameter. All sample values in the decoded picture that are greater than or equal to `max_value`, after conversion to RGB as necessary, are mapped to this maximum value in the `target_bit_depth` representation.

When present, `max_value` shall be greater than or equal to `min_value`.

sigmoid_midpoint specifies the RGB sample value of the coded data that is mapped to the centre point of the `target_bit_depth` representation. It is used in combination with the `sigmoid_width` parameter.

sigmoid_width specifies the distance between two coded data values that approximately correspond to the 5% and 95% values of the `target_bit_depth` representation, respectively. It is used in combination with the `sigmoid_midpoint` parameter and is interpreted according to the following function:

$$f(i) = \text{Round} \left(\frac{2^{\text{target_bit_depth}} - 1}{1 + \exp \left(\frac{-6 * (i - \text{sigmoid_midpoint})}{\text{sigmoid_width}} \right)} \right) \quad (\text{D-17})$$

where $f(i)$ denotes the function that maps an RGB sample value i from the coded data to a resulting RGB sample value in the `target_bit_depth` representation.

start_of_coded_interval[i] specifies the beginning point of an interval in the coded data such that all RGB sample values that are greater than or equal to `start_of_coded_interval`[i] and less than `start_of_coded_interval`[$i + 1$] are mapped to i in the target bit depth representation. The value of `start_of_coded_interval`[$2^{\text{target_bit_depth}}$] is equal to $2^{\text{coded_data_bit_depth}}$. The number of bits used for the representation of the `start_of_coded_interval` is $((\text{coded_data_bit_depth} + 7) \gg 3) \ll 3$.

num_pivots specifies the number of pivot points in the piece-wise linear mapping function without counting the two default end points, $(0, 0)$ and $(2^{\text{coded_data_bit_depth}} - 1, 2^{\text{target_bit_depth}} - 1)$.

coded_pivot_value[i] specifies the value in the `coded_data_bit_depth` corresponding to the i -th pivot point. The number of bits used for the representation of the `coded_pivot_value` is $((\text{coded_data_bit_depth} + 7) \gg 3) \ll 3$.

target_pivot_value[i] specifies the value in the reference `target_bit_depth` corresponding to the i -th pivot point. The number of bits used for the representation of the `target_pivot_value` is $((\text{target_bit_depth} + 7) \gg 3) \ll 3$.

camera_iso_speed_idc indicates the camera ISO speed for daylight illumination as specified in ISO 12232, interpreted as specified in Table D.7. When `camera_iso_speed_idc` indicates EXTENDED_ISO, the ISO speed is indicated by `camera_iso_speed_value`.

camera_iso_speed_value indicates the camera ISO speed for daylight illumination as specified in ISO 12232 when `camera_iso_speed_idc` indicates EXTENDED_ISO. The value of `camera_iso_speed_value` shall not be equal to 0.

exposure_index_idc indicates the exposure index setting of the camera as specified in ISO 12232, interpreted as specified in Table D.7. When `exposure_index_idc` indicates EXTENDED_ISO, the exposure index is indicated by `exposure_index_value`.

The values of `camera_iso_speed_idc` and `exposure_index_idc` in the range of 31 to 254, inclusive, are reserved for future use by ITU-T | ISO/IEC, and shall not be present in bitstreams conforming to this version of this document. Decoders conforming to this version of this document shall ignore tone mapping SEI messages that contain these values.

ISO/IEC 23008-2:2017(E)

exposure_index_value indicates the exposure index setting of the camera as specified in ISO 12232 when **exposure_index_idc** indicates EXTENDED_ISO. The value of **exposure_index_value** shall not be equal to 0.

Table D.7 — Interpretation of camera_iso_speed_idc and exposure_index_idc

camera_iso_speed_idc or exposure_index_idc	Indicated value
0	Unspecified
1	10
2	12
3	16
4	20
5	25
6	32
7	40
8	50
9	64
10	80
11	100
12	125
13	160
14	200
15	250
16	320
17	400
18	500
19	640
20	800
21	1000
22	1250
23	1600
24	2000
25	2500
26	3200
27	4000
28	5000
29	6400
30	8000
31..254	Reserved
255	EXTENDED_ISO

exposure_compensation_value_sign_flag, when applicable as specified below, specifies the sign of the variable ExposureCompensationValue that indicates the exposure compensation value setting used for the process of image production.

exposure_compensation_value_numerator, when applicable as specified below, specifies the numerator of the variable ExposureCompensationValue that indicates the exposure compensation value setting used for the process of image production.

exposure_compensation_value_denom_idc, when not equal to 0, specifies the denominator of the variable ExposureCompensationValue that indicates the exposure compensation value setting used for the process of image production.

When exposure_compensation_value_denom_idc is present and not equal to 0, the variable ExposureCompensationValue is derived from exposure_compensation_value_sign_flag, exposure_compensation_value_numerator and exposure_compensation_value_denom_idc. exposure_compensation_value_sign_flag equal to 0 indicates that the ExposureCompensationValue is positive. exposure_compensation_value_sign_flag equal to 1 indicates that the ExposureCompensationValue is negative. When ExposureCompensationValue is positive, the image is indicated to have been further sensitized through the process of production, relative to the recommended exposure index of the camera as specified in ISO 12232. When ExposureCompensationValue is negative, the image is indicated to have been further desensitized through the process of production, relative to the recommended exposure index of the camera as specified in ISO 12232.

When exposure_compensation_value_denom_idc is present and not equal to 0, the variable ExposureCompensationValue is derived as follows:

$$\text{ExposureCompensationValue} = (1 - 2 * \text{exposure_compensation_value_sign_flag}) * \frac{\text{exposure_compensation_value_numerator}}{\text{exposure_compensation_value_denom_idc}} \quad (\text{D-18})$$

The value of ExposureCompensationValue is interpreted in units of exposure steps such that an increase of 1 in ExposureCompensationValue corresponds to a doubling of exposure in units of lux-seconds. For example, the exposure compensation value equal to +1÷2 at the production stage may be indicated by setting exposure_compensation_value_sign_flag to 0, exposure_compensation_value_numerator to 1, and exposure_compensation_value_denom_idc to 2.

When exposure_compensation_value_denom_idc is present and equal to 0, the exposure compensation value is indicated as unknown or unspecified.

ref_screen_luminance_white indicates the reference screen brightness setting for the extended white level used for image production process in units of candelas per square metre.

extended_range_white_level indicates the luminance dynamic range for extended dynamic-range display of the associated pictures, after conversion to the linear light domain for display, expressed as an integer percentage relative to the nominal white level. The value of extended_range_white_level should be greater than or equal to 100.

nominal_black_level_code_value indicates the luma sample value of the associated decoded pictures to which the nominal black level is assigned. For example, when coded_data_bit_depth is equal to 8, video_full_range_flag is equal to 0, and matrix_coeffs is equal to 1, nominal_black_level_code_value should be equal to 16.

nominal_white_level_code_value indicates the luma sample value of the associated decoded pictures to which the nominal white level is assigned. For example, when coded_data_bit_depth is equal to 8, video_full_range_flag is equal to 0, and matrix_coeffs is equal to 1, nominal_white_level_code_value should be equal to 235. When present, the value of nominal_white_level_code_value shall be greater than nominal_black_level_code_value.

extended_white_level_code_value indicates the luma sample value of the associated decoded pictures to which the white level associated with an extended dynamic range is assigned. When present, the

value of `extended_white_level_code_value` shall be greater than or equal to `nominal_white_level_code_value`.

D.3.16 Frame packing arrangement SEI message semantics

This SEI message informs the decoder that the output cropped decoded picture contains samples of multiple distinct spatially packed constituent frames that are packed into one frame using an indicated frame packing arrangement scheme. This information can be used by the decoder to appropriately rearrange the samples and process the samples of the constituent frames appropriately for display or other purposes (which are outside the scope of this document).

This SEI message may be associated with pictures that are either frames (when `field_seq_flag` is equal to 0) or fields (when `field_seq_flag` is equal to 1). The frame packing arrangement of the samples is specified in terms of the sampling structure of a frame in order to define a frame packing arrangement structure that is invariant with respect to whether a picture is a single field of such a packed frame or is a complete packed frame.

When `general_non_packed_constraint_flag` is equal to 1 for a CVS, there shall be no frame packing arrangement SEI messages in the CVS.

`frame_packing_arrangement_id` contains an identifying number that may be used to identify the usage of the frame packing arrangement SEI message. The value of `frame_packing_arrangement_id` shall be in the range of 0 to $2^{32} - 2$, inclusive.

Values of `frame_packing_arrangement_id` from 0 to 255 and from 512 to $2^{31} - 1$ may be used as determined by the application. Values of `frame_packing_arrangement_id` from 256 to 511 and from 2^{31} to $2^{32} - 2$ are reserved for future use by ITU-T | ISO/IEC. Decoders shall ignore all frame packing arrangement SEI messages containing a value of `frame_packing_arrangement_id` in the range of 256 to 511, inclusive, or in the range of 2^{31} to $2^{32} - 2$, inclusive, and bitstreams shall not contain such values.

`frame_packing_arrangement_cancel_flag` equal to 1 indicates that the frame packing arrangement SEI message cancels the persistence of any previous frame packing arrangement SEI message in output order that applies to the current layer. `frame_packing_arrangement_cancel_flag` equal to 0 indicates that frame packing arrangement information follows.

`frame_packing_arrangement_type` indicates the type of packing arrangement of the frames as specified in Table D.8.

Table D.8 — Definition of `frame_packing_arrangement_type`

Value	Interpretation
3	Each component plane of the decoded frames contains a side-by-side packing arrangement of corresponding planes of two constituent frames as illustrated in Figure D.4, Figure D.5, and Figure D.8.
4	Each component plane of the decoded frames contains a top-bottom packing arrangement of corresponding planes of two constituent frames as illustrated in Figure D.6 and Figure D.7.
5	The component planes of the decoded frames in output order form a temporal interleaving of alternating first and second constituent frames as illustrated in Figure D.9.

NOTE 1 Figure D.4 to Figure D.8 provide typical examples of rearrangement and upconversion processing for various packing arrangement schemes. Actual characteristics of the constituent frames are signalled in detail by the subsequent syntax elements of the frame packing arrangement SEI message. In Figure D.4 to Figure D.8, an upconversion processing is performed on each constituent frame to produce frames having the same resolution as that of the decoded frame. An example of the upsampling method to be applied to a quincunx sampled frame as shown in Figure D.8 is to fill in missing positions with an average of the available spatially neighbouring samples (the average of the values of the available samples above, below, to the left and to the right of each sample to be generated). The actual upconversion process to be performed, if any, is outside the scope of this document.

NOTE 2 When the output time of the samples of constituent frame 0 differs from the output time of the samples of constituent frame 1 (i.e. when `field_views_flag` is equal to 1 or `frame_packing_arrangement_type` is equal to 5) and the display system in use presents two views simultaneously, the display time for constituent frame 0 should be delayed to coincide with the display time for constituent frame 1. (The display process is not specified in this document.)

NOTE 3 When `field_views_flag` is equal to 1 or `frame_packing_arrangement_type` is equal to 5, the value 0 for `fixed_pic_rate_within_cvs_flag` is not expected to be prevalent in industry use of this SEI message.

NOTE 4 `frame_packing_arrangement_type` equal to 5 describes a temporal interleaving process of different views.

All other values of `frame_packing_arrangement_type` are reserved for future use by ITU-T | ISO/IEC. It is a requirement of bitstream conformance that bitstreams conforming to this version of this document shall not contain such other values of `frame_packing_arrangement_type`. Decoders shall ignore frame packing arrangement SEI messages that contain reserved values of `frame_packing_arrangement_type`.

quincunx_sampling_flag equal to 1 indicates that each colour component plane of each constituent frame is quincunx sampled as illustrated in Figure D.8, and `quincunx_sampling_flag` equal to 0 indicates that the colour component planes of each constituent frame are not quincunx sampled.

When `frame_packing_arrangement_type` is equal to 5, it is a requirement of bitstream conformance that `quincunx_sampling_flag` shall be equal to 0.

NOTE 5 For any chroma format (4:2:0, 4:2:2, or 4:4:4), the luma plane and each chroma plane is quincunx sampled as illustrated in Figure D.8 when `quincunx_sampling_flag` is equal to 1.

content_interpretation_type indicates the intended interpretation of the constituent frames as specified in Table D.9. Values of `content_interpretation_type` that do not appear in Table D.9 are reserved for future specification by ITU-T | ISO/IEC and shall not be present in bitstreams conforming to this version of this document. Decoders shall ignore frame packing arrangement SEI messages that contain reserved values of `content_interpretation_type`.

For each specified frame packing arrangement scheme, there are two constituent frames that are referred to as frame 0 and frame 1.

Table D.9—Definition of `content_interpretation_type`

Value	Interpretation
0	Unspecified relationship between the frame packed constituent frames
1	Indicates that the two constituent frames form the left and right views of a stereo view scene, with frame 0 being associated with the left view and frame 1 being associated with the right view
2	Indicates that the two constituent frames form the right and left views of a stereo view scene, with frame 0 being associated with the right view and frame 1 being associated with the left view

NOTE 6 The value 2 for `content_interpretation_type` is not expected to be prevalent in industry use of this SEI message. However, the value was specified herein for purposes of completeness.

spatial_flipping_flag equal to 1, when `frame_packing_arrangement_type` is equal to 3 or 4, indicates that one of the two constituent frames is spatially flipped relative to its intended orientation for display or other such purposes.

When `frame_packing_arrangement_type` is equal to 3 or 4 and `spatial_flipping_flag` is equal to 1, the type of spatial flipping that is indicated is as follows:

- If `frame_packing_arrangement_type` is equal to 3, the indicated spatial flipping is horizontal flipping.
- Otherwise (`frame_packing_arrangement_type` is equal to 4), the indicated spatial flipping is vertical flipping.

When `frame_packing_arrangement_type` is not equal to 3 or 4, it is a requirement of bitstream conformance that `spatial_flipping_flag` shall be equal to 0. When `frame_packing_arrangement_type` is not equal to 3 or 4, the value 1 for `spatial_flipping_flag` is reserved for future use by ITU-T | ISO/IEC. When `frame_packing_arrangement_type` is not equal to 3 or 4, decoders shall ignore the value 1 for `spatial_flipping_flag`.

frame0_flipped_flag, when `spatial_flipping_flag` is equal to 1, indicates which one of the two constituent frames is flipped.

When `spatial_flipping_flag` is equal to 1, `frame0_flipped_flag` equal to 0 indicates that frame 0 is not spatially flipped and frame 1 is spatially flipped, and `frame0_flipped_flag` equal to 1 indicates that frame 0 is spatially flipped and frame 1 is not spatially flipped.

When `spatial_flipping_flag` is equal to 0, it is a requirement of bitstream conformance that `frame0_flipped_flag` shall be equal to 0. When `spatial_flipping_flag` is equal to 0, the value 1 for `spatial_flipping_flag` is reserved for future use by ITU-T | ISO/IEC. When `spatial_flipping_flag` is equal to 0, decoders shall ignore the value of `frame0_flipped_flag`.

field_views_flag equal to 1 indicates that all pictures in the current CVS are coded as fields, all fields of a particular parity are considered a first constituent frame, and all fields of the opposite parity are considered a second constituent frame. It is a requirement of bitstream conformance that the `field_views_flag` shall be equal to 0, the value 1 for `field_views_flag` is reserved for future use by ITU-T | ISO/IEC, and decoders shall ignore the value of `field_views_flag`.

current_frame_is_frame0_flag equal to 1, when `frame_packing_arrangement` is equal to 5, indicates that the current decoded frame is constituent frame 0 and the next decoded frame in output order is constituent frame 1, and the display time of the constituent frame 0 should be delayed to coincide with the display time of constituent frame 1. `current_frame_is_frame0_flag` equal to 0, when `frame_packing_arrangement` is equal to 5, indicates that the current decoded frame is constituent frame 1 and the previous decoded frame in output order is constituent frame 0, and the display time of the constituent frame 1 should not be delayed for purposes of stereo-view pairing.

When `frame_packing_arrangement_type` is not equal to 5, the constituent frame associated with the upper-left sample of the decoded frame is considered to be constituent frame 0 and the other constituent frame is considered to be constituent frame 1. When `frame_packing_arrangement_type` is not equal to 5, it is a requirement of bitstream conformance that `current_frame_is_frame0_flag` shall be equal to 0. When `frame_packing_arrangement_type` is not equal to 5, the value 1 for `current_frame_is_frame0_flag` is reserved for future use by ITU-T | ISO/IEC. When `frame_packing_arrangement_type` is not equal to 5, decoders shall ignore the value of `current_frame_is_frame0_flag`.

frame0_self_contained_flag equal to 1 indicates that no inter prediction operations within the decoding process for the samples of constituent frame 0 of the CVS refer to samples of any constituent frame 1. `frame0_self_contained_flag` equal to 0 indicates that some inter prediction operations within the decoding process for the samples of constituent frame 0 of the CVS may or may not refer to samples of some constituent frame 1. Within a CVS, the value of `frame0_self_contained_flag` in all frame packing arrangement SEI messages shall be the same.

frame1_self_contained_flag equal to 1 indicates that no inter prediction operations within the decoding process for the samples of constituent frame 1 of the CVS refer to samples of any constituent frame 0. **frame1_self_contained_flag** equal to 0 indicates that some inter prediction operations within the decoding process for the samples of constituent frame 1 of the CVS may or may not refer to samples of some constituent frame 0. Within a CVS, the value of **frame1_self_contained_flag** in all frame packing arrangement SEI messages shall be the same.

When **quincunx_sampling_flag** is equal to 0 and **frame_packing_arrangement_type** is not equal to 5, two (x, y) coordinate pairs are specified to determine the indicated luma sampling grid alignment for constituent frame 0 and constituent frame 1, relative to the upper left corner of the rectangular area represented by the samples of the corresponding constituent frame.

NOTE 7 The location of chroma samples relative to luma samples can be indicated by the **chroma_sample_loc_type_top_field** and **chroma_sample_loc_type_bottom_field** syntax elements in the VUI parameters.

frame0_grid_position_x (when present) specifies the x component of the (x, y) coordinate pair for constituent frame 0.

frame0_grid_position_y (when present) specifies the y component of the (x, y) coordinate pair for constituent frame 0.

frame1_grid_position_x (when present) specifies the x component of the (x, y) coordinate pair for constituent frame 1.

frame1_grid_position_y (when present) specifies the y component of the (x, y) coordinate pair for constituent frame 1.

When **quincunx_sampling_flag** is equal to 0 and **frame_packing_arrangement_type** is not equal to 5 the (x, y) coordinate pair for each constituent frame is interpreted as follows:

- If the (x, y) coordinate pair for a constituent frame is equal to $(0, 0)$, this indicates a default sampling grid alignment specified as follows:
 - If **frame_packing_arrangement_type** is equal to 3, the indicated position is the same as for the (x, y) coordinate pair value $(4, 8)$, as illustrated in Figure D.4.
 - Otherwise (**frame_packing_arrangement_type** is equal to 4), the indicated position is the same as for the (x, y) coordinate pair value $(8, 4)$, as illustrated in Figure D.6.
- Otherwise, if the (x, y) coordinate pair for a constituent frame is equal to $(15, 15)$, this indicates that the sampling grid alignment is unknown or unspecified or specified by other means not specified in this document.
- Otherwise, the x and y elements of the (x, y) coordinate pair specify the indicated horizontal and vertical sampling grid alignment positioning to the right of and below the upper left corner of the rectangular area represented by the corresponding constituent frame, respectively, in units of one sixteenth of the luma sample grid spacing between the samples of the columns and rows of the constituent frame that are present in the decoded frame (prior to any upsampling for display or other purposes).

NOTE 8 The spatial location reference information **frame0_grid_position_x**, **frame0_grid_position_y**, **frame1_grid_position_x**, and **frame1_grid_position_y** is not provided when **quincunx_sampling_flag** is equal to 1 because the spatial alignment in this case is assumed to be such that constituent frame 0 and constituent frame 1 cover corresponding spatial areas with interleaved quincunx sampling patterns as illustrated in Figure D.8.

frame_packing_arrangement_reserved_byte is reserved for future use by ITU-T | ISO/IEC. It is a requirement of bitstream conformance that the value of **frame_packing_arrangement_reserved_byte** shall be equal to 0. All other values of **frame_packing_arrangement_reserved_byte** are reserved for

ISO/IEC 23008-2:2017(E)

future use by ITU-T | ISO/IEC. Decoders shall ignore the value of `frame_packing_arrangement_reserved_byte`.

frame_packing_arrangement_persistence_flag specifies the persistence of the frame packing arrangement SEI message for the current layer.

`frame_packing_arrangement_persistence_flag` equal to 0 specifies that the frame packing arrangement SEI message applies to the current decoded frame only.

Let `picA` be the current picture. `frame_packing_arrangement_persistence_flag` equal to 1 specifies that the frame packing arrangement SEI message persists for the current layer in output order until any of the following conditions are true:

- A new CLVS of the current layer begins.
- The bitstream ends.
- A frame `picB` in the current layer in an access unit containing a frame packing arrangement SEI message with the same value of `frame_packing_arrangement_id` and applicable to the current layer is output for which `PicOrderCnt(picB)` is greater than `PicOrderCnt(picA)`, where `PicOrderCnt(picB)` and `PicOrderCnt(picA)` are the `PicOrderCntVal` values of `picB` and `picA`, respectively, immediately after the invocation of the decoding process for picture order count for `picB`.

upsampled_aspect_ratio_flag equal to 1 indicates that the sample aspect ratio (SAR) indicated by the VUI parameters of the SPS identifies the SAR of the samples after the application of an upconversion process to produce a higher resolution frame from each constituent frame as illustrated in Figure D.4 to Figure D.8. `upsampled_aspect_ratio_flag` equal to 0 indicates that the SAR indicated by the VUI parameters of the SPS identifies the SAR of the samples before the application of any such upconversion process.

NOTE 9 The default display window parameters in the VUI parameters of the SPS can be used by an encoder to indicate to a decoder that does not interpret the frame packing arrangement SEI message that the default display window is an area within only one of the two constituent frames.

NOTE 10 The SAR indicated in the VUI parameters are expected to indicate the preferred display picture shape for the packed decoded frame output by a decoder that does not interpret the frame packing arrangement SEI message. When `upsampled_aspect_ratio_flag` is equal to 1, the SAR produced in each up-converted colour plane is indicated to be the same as the SAR indicated in the VUI parameters in the examples shown in Figure D.4 to Figure D.8. When `upsampled_aspect_ratio_flag` is equal to 0, the SAR produced in each colour plane prior to upconversion is indicated to be the same as the SAR indicated in the VUI parameters in the examples shown in Figure D.4 to Figure D.8.

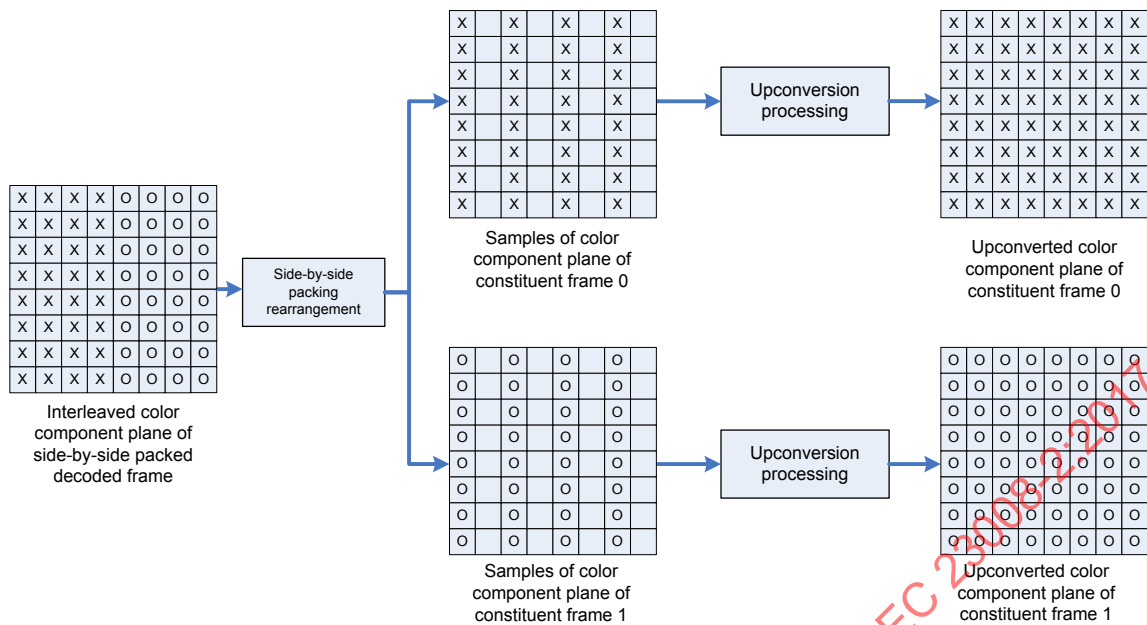

Figure D.4 — Rearrangement and upconversion of side-by-side packing arrangement with frame_packing_arrangement_type equal to 3, quincunx_sampling_flag equal to 0, and (x, y) equal to (0, 0) or (4, 8) for both constituent frames

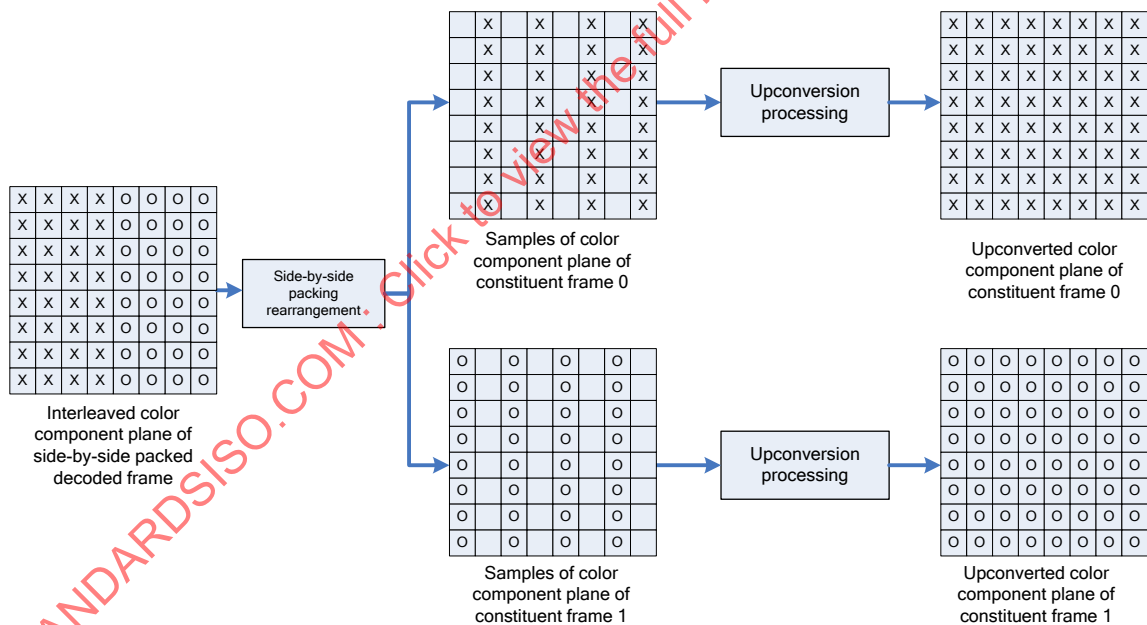

Figure D.5 — Rearrangement and upconversion of side-by-side packing arrangement with frame_packing_arrangement_type equal to 3, quincunx_sampling_flag equal to 0, (x, y) equal to (12, 8) for constituent frame 0, and (x, y) equal to (0, 0) or (4, 8) for constituent frame 1

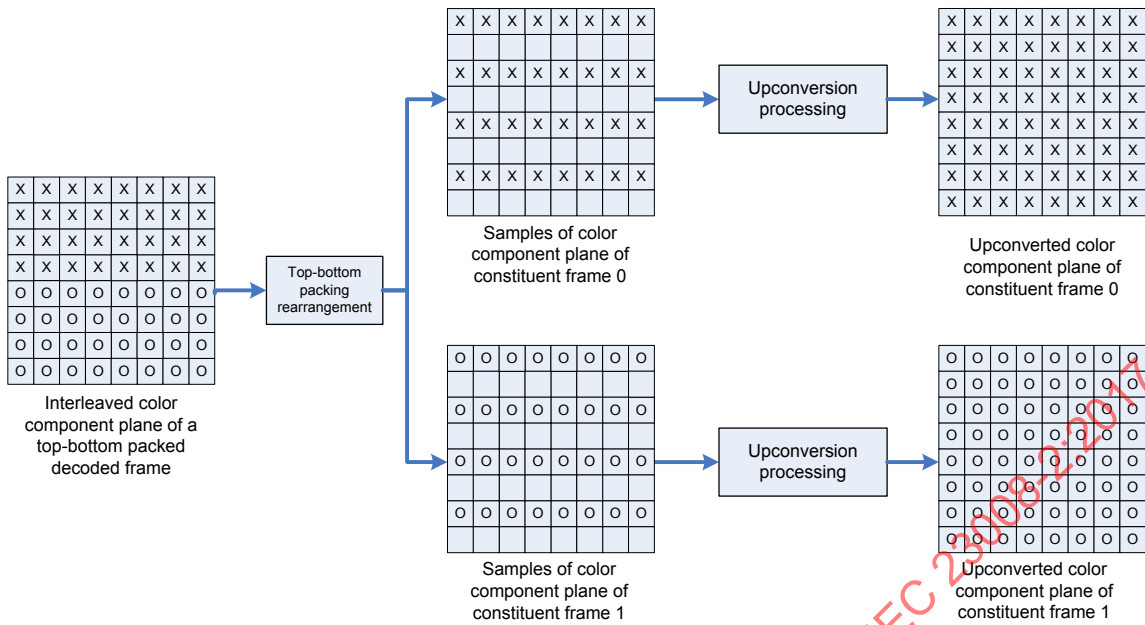

Figure D.6 — Rearrangement and upconversion of top-bottom packing arrangement with `frame_packing_arrangement_type` equal to 4, `quincunx_sampling_flag` equal to 0, and (x, y) equal to $(0, 0)$ or $(8, 4)$ for both constituent frames

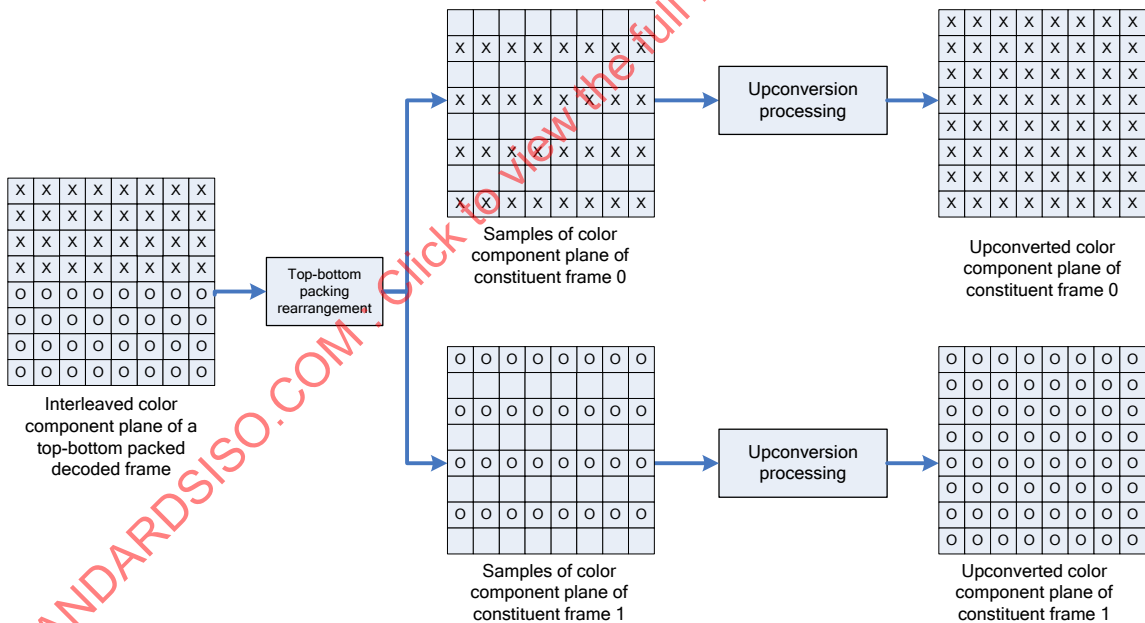

Figure D.7 — Rearrangement and upconversion of top-bottom packing arrangement with `frame_packing_arrangement_type` equal to 4, `quincunx_sampling_flag` equal to 0, (x, y) equal to $(8, 12)$ for constituent frame 0, and (x, y) equal to $(0, 0)$ or $(8, 4)$ for constituent frame 1

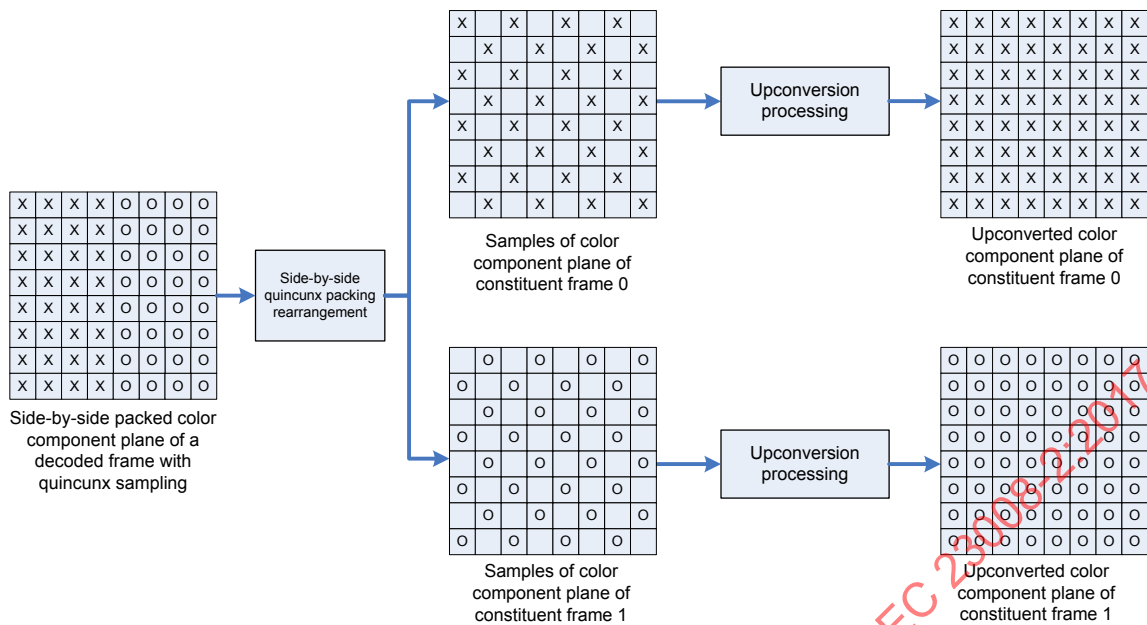

Figure D.8 — Rearrangement and upconversion of side-by-side packing arrangement with quincunx sampling (frame_packing_arrangement_type equal to 3 with quincunx_sampling_flag equal to 1)

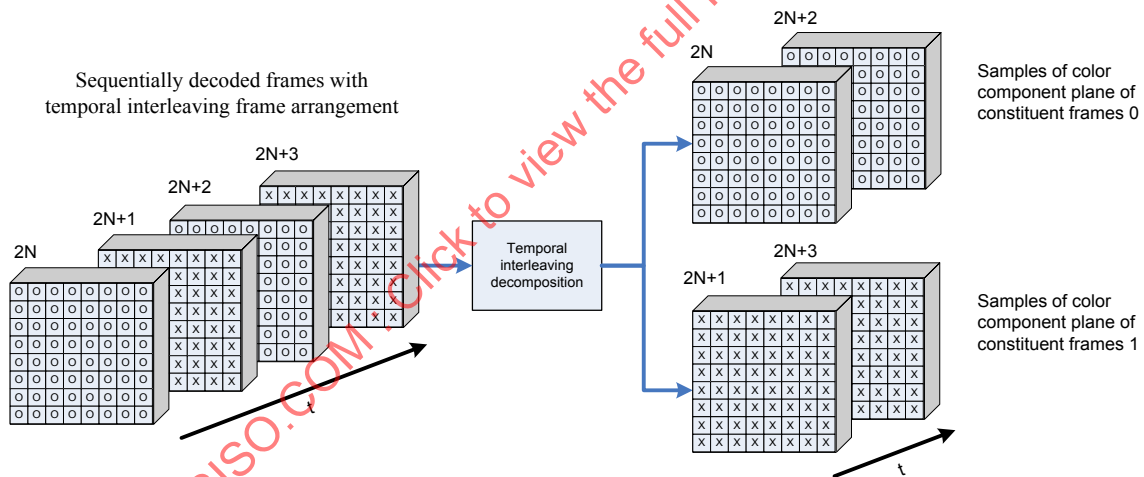

Figure D.9 — Rearrangement of a temporal interleaving frame arrangement (frame_packing_arrangement_type equal to 5)

D.3.17 Display orientation SEI message semantics

When the associated picture has PicOutputFlag equal to 1, the display orientation SEI message informs the decoder of a transformation that is recommended to be applied to the cropped decoded picture prior to display.

display_orientation_cancel_flag equal to 1 indicates that the SEI message cancels the persistence of any previous display orientation SEI message in output order. display_orientation_cancel_flag equal to 0 indicates that display orientation information follows.

hor_flip equal to 1 indicates that the cropped decoded picture should be flipped horizontally for display. hor_flip equal to 0 indicates that the decoded picture should not be flipped horizontally.

ISO/IEC 23008-2:2017(E)

When `hor_flip` is equal to 1, the cropped decoded picture should be flipped as follows for each component `Z` equal to `Y`, `Cb`, and `Cr`, letting `dZ` be the final cropped array of output samples for the component `Z`:

```
for( x = 0; x < croppedWidthZ; x++ )
    for( y = 0; y < croppedHeightZ; y++ )
        dZ[ x ][ y ] = Z[ croppedWidthZ - x - 1 ][ y ]
```

 (D-19)

Where `croppedWidthZ` is the width of the component `Z` of the cropped decoded picture in samples, `croppedHeightZ` is the height of the component `Z` of the cropped decoded picture in samples, and `Z[x][y]` and `dZ[x][y]` are the sample value before and after the horizontal flipping, respectively, for the sample at the location (x, y) of the component `Z` of the cropped decoded picture.

ver_flip equal to 1 indicates that the cropped decoded picture should be flipped vertically (in addition to any horizontal flipping when `hor_flip` is equal to 1) for display. `ver_flip` equal to 0 indicates that the decoded picture should not be flipped vertically.

When `ver_flip` is equal to 1, the cropped decoded picture should be flipped as follows for each component `Z` equal to `Y`, `Cb`, and `Cr`, letting `dZ` be the final cropped array of output samples for the component `Z`:

```
for( x = 0; x < croppedWidthZ; x++ )
    for( y = 0; y < croppedHeightZ; y++ )
        dZ[ x ][ y ] = Z[ x ][ croppedWidthZ - y - 1 ]
```

 (D-20)

Where `croppedWidthZ` is the width of the component `Z` of the cropped decoded picture in samples, `croppedHeightZ` is the height of the component `Z` of the cropped decoded picture in samples, and `Z[x][y]` and `dZ[x][y]` are the sample value before and after the vertical flipping, respectively, for the sample at the location (x, y) of the component `Z` of the cropped decoded picture.

anticlockwise_rotation specifies the recommended anticlockwise rotation of the decoded picture (after applying horizontal or vertical flipping when `hor_flip` or `ver_flip` is set) prior to display. The decoded picture should be rotated by $360 * \text{anticlockwise_rotation} \div 2^{16}$ degrees ($2 * \pi * \text{anticlockwise_rotation} \div 2^{16}$ radians, where π is Archimedes' constant 3.141 592 653 589 793...) in the anticlockwise direction prior to display. For example, `anticlockwise_rotation` equal to 0 indicates no rotation and `anticlockwise_rotation` equal to 16 384 indicates 90 degrees ($\pi \div 2$ radians) rotation in the anticlockwise direction.

NOTE It is possible for equivalent transformations to be expressed in multiple ways using these syntax elements. For example, the combination of having both `hor_flip` and `ver_flip` equal to 1 with `anticlockwise_rotation` equal to 0 can alternatively be expressed by having both `hor_flip` and `ver_flip` equal to 1 with `anticlockwise_rotation` equal to 0x8000000, and the combination of `hor_flip` equal to 1 with `ver_flip` equal to 0 and `anticlockwise_rotation` equal to 0 can alternatively be expressed by having `hor_flip` equal to 0 with `ver_flip` equal to 1 and `anticlockwise_rotation` equal to 0x8000000.

display_orientation_persistence_flag specifies the persistence of the display orientation SEI message for the current layer.

`display_orientation_persistence_flag` equal to 0 specifies that the display orientation SEI message applies to the current decoded picture only.

Let `picA` be the current picture. `display_orientation_persistence_flag` equal to 1 specifies that the display orientation SEI message persists for the current layer in output order until one or more of the following conditions are true:

- A new CLVS of the current layer begins.
- The bitstream ends.
- A picture `picB` in the current layer in an access unit containing a display orientation SEI message that is applicable to the current layer is output for which `PicOrderCnt(picB)` is greater than

$\text{PicOrderCnt}(\text{picA})$, where $\text{PicOrderCnt}(\text{picB})$ and $\text{PicOrderCnt}(\text{picA})$ are the PicOrderCntVal values of picB and picA , respectively, immediately after the invocation of the decoding process for picture order count for picB .

D.3.18 Green metadata SEI message semantics

The semantics for this SEI message are specified in ISO/IEC 23001-11 (Green metadata). Green metadata facilitates reduced power consumption in decoders, encoders, displays and in media selection.

D.3.19 Structure of pictures information SEI message semantics

The structure of pictures information SEI message provides information for a list of entries, some of which correspond to the target picture set that consists of a series of pictures starting from the current picture until the last picture in decoding order in the current layer in the CLVS.

The first entry in the structure of pictures information SEI message corresponds to the current picture. When there is a picture in the target picture set that has PicOrderCntVal equal to the variable entry $\text{PicOrderCnt}[i]$ as specified below, the entry i corresponds to a picture in the target picture set. The decoding order of the pictures in the target picture set that correspond to entries in the structure of pictures information SEI message corresponds to increasing values of i in the list of entries.

Any picture picB in the target picture set that has PicOrderCntVal equal to entry $\text{PicOrderCnt}[i]$ for any i in the range of 0 to $\text{num_entries_in_sop_minus1}$, inclusive, where PicOrderCntVal is the value of PicOrderCntVal of picB immediately after the invocation of the decoding process for picture order count for picB , shall correspond to an entry in the list of entries.

The structure of pictures information SEI message shall not be present in a CVS and applicable for a layer for which the active SPS has $\text{long_term_ref_pics_present_flag}$ equal to 1 or $\text{num_short_term_ref_pic_sets}$ equal to 0.

The structure of pictures information SEI message shall not be present in any access unit that has TemporalId greater than 0 or contains a RASL, RADL, or SLNR picture in the current layer. Any picture in the target picture set that corresponds to an entry other than the first entry described in the structure of pictures information SEI message shall not be an IRAP picture.

sop_seq_parameter_set_id indicates and shall be equal to the $\text{sps_seq_parameter_set_id}$ value of the active SPS. The value of $\text{sop_seq_parameter_set_id}$ shall be in the range of 0 to 15, inclusive.

num_entries_in_sop_minus1 plus 1 specifies the number of entries in the structure of pictures information SEI message. $\text{num_entries_in_sop_minus1}$ shall be in the range of 0 to 1023, inclusive.

sop_vcl_nut[i], when the i -th entry corresponds to a picture in the target picture set, indicates and shall be equal to the nal_unit_type value of the picture corresponding to the i -th entry.

sop_temporal_id[i], when the i -th entry corresponds to a picture in the target picture set, indicates and shall be equal to the TemporalId value of the picture corresponding to the i -th entry. The value of 7 for $\text{sop_temporal_id}[i]$ is reserved for future use by ITU-T | ISO/IEC and shall not be present in bitstreams conforming to this version of this document. Decoders shall ignore structure of pictures information SEI messages that contain the value 7 for $\text{sop_temporal_id}[i]$.

sop_short_term_rps_idx[i], when the i -th entry corresponds to a picture in the target picture set, indicates and shall be equal to the index, into the list of candidate short-term RPSs included in the active SPS, of the candidate short-term RPS used by the picture corresponding to the i -th entry for derivation of the short-term reference picture set. $\text{sop_short_term_rps_idx}[i]$ shall be in the range of 0 to $\text{num_short_term_ref_pic_sets} - 1$, inclusive.

sop_poc_delta[i] is used to specify the value of the variable entry $\text{PicOrderCnt}[i]$ for the i -th entry described in the structure of pictures information SEI message. $\text{sop_poc_delta}[i]$ shall be in the range of $(-\text{MaxPicOrderCntLsb}) / 2 + 1$ to $\text{MaxPicOrderCntLsb} / 2 - 1$, inclusive.

The variable entry $\text{PicOrderCnt}[i]$ is derived as follows:

ISO/IEC 23008-2:2017(E)

```
entryPicOrderCnt[ 0 ] = PicOrderCnt( currPic )
for( i = 1; i <= num_entries_in_sop_minus1; i++ )
    entryPicOrderCnt[ i ] = entryPicOrderCnt[ i - 1 ] + sop_poc_delta[ i ]
```

(D-21)

where currPic is the current picture.

D.3.20 Decoded picture hash SEI message semantics

This message provides a hash for each colour component of the current decoded picture.

NOTE 1 The decoded picture hash SEI message is a suffix SEI message and cannot be contained in a scalable nesting SEI message.

Prior to computing the hash, the decoded picture data are arranged into one or three strings of bytes called pictureData[cIdx] of lengths dataLen[cIdx] as follows:

```
for( cIdx = 0; cIdx < ( chroma_format_idc == 0 ) ? 1 : 3; cIdx++ ) {
    if( cIdx == 0 ) {
        compWidth[ cIdx ] = pic_width_in_luma_samples
        compHeight[ cIdx ] = pic_height_in_luma_samples
        compDepth[ cIdx ] = BitDepthv
    } else {
        compWidth[ cIdx ] = pic_width_in_luma_samples / SubWidthC
        compHeight[ cIdx ] = pic_height_in_luma_samples / SubHeightC
        compDepth[ cIdx ] = BitDepthc
    }
    iLen = 0
    for( i = 0; i < compWidth[ cIdx ] * compHeight[ cIdx ]; i++ ) {
        pictureData[ cIdx ][ iLen++ ] = component[ cIdx ][ i ] & 0xFF
        if( compDepth[ cIdx ] > 8 )
            pictureData[ cIdx ][ iLen++ ] = component[ cIdx ][ i ] >> 8
    }
    dataLen[ cIdx ] = iLen
}
```

(D-22)

where component[cIdx][i] is an array in raster scan of decoded sample values in two's complement representation.

hash_type indicates the method used to calculate the checksum according to Table D.10. Values of hash_type that are not listed in Table D.10 are reserved for future use by ITU-T | ISO/IEC and shall not be present in bitstreams conforming to this version of this document. Decoders shall ignore decoded picture hash SEI messages that contain reserved values of hash_type.

Table D.10 — Interpretation of hash_type

hash_type	Method
0	MD5 (RFC 1321)
1	CRC
2	Checksum

picture_md5[cIdx][i] is the 16-byte MD5 hash of the cIdx-th colour component of the decoded picture. The value of picture_md5[cIdx][i] shall be equal to the value of digestVal[cIdx] obtained as follows, using the MD5 functions defined in RFC 1321:

```
MD5Init( context )
MD5Update( context, pictureData[ cIdx ], dataLen[ cIdx ] )
MD5Final( digestVal[ cIdx ], context )
```

(D-23)

picture_crc[cIdx] is the cyclic redundancy check (CRC) of the colour component cIdx of the decoded picture. The value of picture_crc[cIdx] shall be equal to the value of crcVal[cIdx] obtained as follows:

```

crc = 0xFFFF
pictureData[ cIdx ][ dataLen[ cIdx ] ] = 0
pictureData[ cIdx ][ dataLen[ cIdx ] + 1 ] = 0
for( bitIdx = 0; bitIdx < ( dataLen[ cIdx ] + 2 ) * 8; bitIdx++ ) {
    dataByte = pictureData[ cIdx ][ bitIdx >> 3 ]
    crcMsb = ( crc >> 15 ) & 1
    bitVal = ( dataByte >> ( 7 - ( bitIdx & 7 ) ) ) & 1
    crc = ( ( ( crc << 1 ) + bitVal ) & 0xFFFF ) ^ ( crcMsb * 0x1021 )
}
crcVal[ cIdx ] = crc

```

(D-24)

NOTE 2 The same CRC specification is found in Rec. ITU-T H.271.

picture_checksum[cIdx] is the checksum of the colour component cIdx of the decoded picture. The value of picture_checksum[cIdx] shall be equal to the value of checksumVal[cIdx] obtained as follows:

```

sum = 0
for( y = 0; y < compHeight[ cIdx ]; y++ )
    for( x = 0; x < compWidth[ cIdx ]; x++ ) {
        xorMask = ( x & 0xFF ) ^ ( y & 0xFF ) ^ ( x >> 8 ) ^ ( y >> 8 )
        sum = ( sum + ( ( component[ cIdx ][ y * compWidth[ cIdx ] + x ] & 0xFF ) ^ xorMask ) ) &
            0xFFFFFFFF
        if( compDepth[ cIdx ] > 8 )
            sum = ( sum + ( ( component[ cIdx ][ y * compWidth[ cIdx ] + x ] >> 8 ) ^ xorMask ) ) &
                0xFFFFFFFF
    }
checksumVal[ cIdx ] = sum

```

(D-25)

D.3.21 Active parameter sets SEI message semantics

The active parameter sets SEI message indicates which VPS is active for the VCL NAL units of the access unit associated with the SEI message. The SEI message may also provide information on which SPS is active for the VCL NAL units of the access unit associated with the SEI message, and other information related to parameter sets.

active_video_parameter_set_id indicates and shall be equal to the value of the vps_video_parameter_set_id of the VPS that is referred to by the VCL NAL units of the access unit associated with the SEI message. The value of active_video_parameter_set_id shall be in the range of 0 to 15, inclusive.

self_contained_cvs_flag equal to 1 indicates that each parameter set that is (directly or indirectly) referenced by any VCL NAL unit of the CVS that is not a VCL NAL unit of a RASL picture is present within the CVS at a position that precedes, in decoding order, any NAL unit that (directly or indirectly) references the parameter set. self_contained_cvs_flag equal to 0 indicates that this property may or may not apply.

no_parameter_set_update_flag equal to 1 indicates that there is no parameter set update in the CVS, i.e. each VPS in the CVS is an exact copy of the previous VPS in decoding order in the bitstream that has the same value of vps_video_parameter_set_id, when present; each SPS in the CVS is an exact copy of the previous SPS in decoding order in the bitstream that has the same value of sps_seq_parameter_set_id, when present; and each PPS in the CVS is an exact copy of the previous PPS in decoding order in the bitstream that has the same value of pps_pic_parameter_set_id, when present. no_parameter_set_update_flag equal to 0 indicates that there may or may not be parameter set update in the CVS.

ISO/IEC 23008-2:2017(E)

NOTE 1 If `no_parameter_set_update_flag` equal to 1 is indicated for each CVS in a bitstream, i.e. there is no parameter set update in the bitstream, it is possible to transmit all parameter sets out-of-band before sending the first VCL NAL unit of the bitstream or to place all parameter sets at the beginning of the bitstream. Otherwise, out-of-band transmission of all parameter sets before sending VCL NAL units is not possible.

`num_sps_ids_minus1` plus 1 shall be less than or equal to the number of SPSs that are referred to by the VCL NAL units of the access unit associated with the active parameter sets SEI message. The value of `num_sps_ids_minus1` shall be in the range of 0 to 15, inclusive.

`active_seq_parameter_set_id`[*i*] indicates a value of the `sps_seq_parameter_set_id` of the SPS that may be referred to by any VCL NAL unit of the access unit associated with the SEI message. When `vps_base_layer_internal_flag` is equal to 1 and `vps_base_layer_available_flag` is equal to 1, `active_seq_parameter_set_id`[0] indicates and shall be equal to the value of the `sps_seq_parameter_set_id` of the SPS that is referred to by the VCL NAL units with `nuh_layer_id` equal to 0 in the access unit associated with the SEI message. The value of `active_seq_parameter_set_id`[*i*] shall be in the range of 0 to 15, inclusive.

`layer_sps_idx`[*i*] indicates that the `sps_seq_parameter_set_id` value of the SPS that is referred to by the VCL NAL units with `nuh_layer_id` equal to `layer_id_in_nuh`[*i*] in the access unit associated with the SEI message, if any, is equal to `active_seq_parameter_set_id`[`layer_sps_idx`[*i*]].

NOTE 2 When decoding a single-layer bitstream or only the base layer of a multi-layer bitstream, the decoder does not need to parse `layer_sps_idx`[*i*] syntax elements, because they do not affect the decoding of the base layer.

D.3.22 Decoding unit information SEI message semantics

The decoding unit information SEI message provides CPB removal delay information for the decoding unit associated with the SEI message.

When the buffering period SEI message is non-nested or is directly contained in a scalable nesting SEI message within an SEI NAL unit with `nuh_layer_id` equal to 0, the following applies for the decoding unit information SEI message syntax and semantics:

- The syntax elements `sub_pic_hrd_params_present_flag`, `sub_pic_cpb_params_in_pic_timing_sei_flag`, and `dpb_output_delay_du_length_minus1`, and the variable `CpbDpbDelaysPresentFlag` are found in or derived from syntax elements in the `hrd_parameters`() syntax structure that is applicable to at least one of the operation points to which the decoding unit information SEI message applies.
- The bitstream (or a part thereof) refers to the bitstream subset (or a part thereof) associated with any of the operation points to which the decoding unit information SEI message applies.

The presence of decoding unit information SEI messages for an operation point including the base layer is specified as follows:

- If `CpbDpbDelaysPresentFlag` is equal to 1, `sub_pic_hrd_params_present_flag` is equal to 1, and `sub_pic_cpb_params_in_pic_timing_sei_flag` is equal to 0, one or more decoding unit information SEI messages applicable to the operation point shall be associated with each decoding unit in the CVS.
- Otherwise, if `CpbDpbDelaysPresentFlag` is equal to 1, `sub_pic_hrd_params_present_flag` is equal to 1, and `sub_pic_cpb_params_in_pic_timing_sei_flag` is equal to 1, one or more decoding unit information SEI messages applicable to the operation point may or may not be associated with each decoding unit in the CVS.
- Otherwise (`CpbDpbDelaysPresentFlag` is equal to 0 or `sub_pic_hrd_params_present_flag` is equal to 0), in the CVS there shall be no decoding unit that is associated with a decoding unit information SEI message applicable to the operation point.

When the buffering period SEI message is non-nested or is directly contained in a scalable nesting SEI message within an SEI NAL unit with `nuh_layer_id` equal to 0, the set of NAL units associated with a decoding unit information SEI message consists, in decoding order, of the SEI NAL unit containing the decoding unit information SEI message and all subsequent NAL units in the access unit up to but not including any subsequent SEI NAL unit containing a decoding unit information SEI message with a different value of `decoding_unit_idx`. Each decoding unit shall include at least one VCL NAL unit. All non-VCL NAL units associated with a VCL NAL unit shall be included in the decoding unit containing the VCL NAL unit.

decoding_unit_idx specifies the index, starting from 0, to the list of decoding units in the current access unit, of the decoding unit associated with the decoding unit information SEI message. The value of `decoding_unit_idx` shall be in the range of 0 to `PicSizeInCtbsY - 1`, inclusive.

A decoding unit identified by a particular value of `duIdx` includes and only includes all NAL units associated with all decoding unit information SEI messages that have `decoding_unit_idx` equal to `duIdx`. Such a decoding unit is also referred to as associated with the decoding unit information SEI messages having `decoding_unit_idx` equal to `duIdx`.

For any two decoding units `duA` and `duB` in one access unit with `decoding_unit_idx` equal to `duIdxA` and `duIdxB`, respectively, where `duIdxA` is less than `duIdxB`, `duA` shall precede `duB` in decoding order.

A NAL unit of one decoding unit shall not be present, in decoding order, between any two NAL units of another decoding unit.

du_spt_cpb_removal_delay_increment specifies the duration, in units of clock sub-ticks, between the nominal CPB times of the last decoding unit in decoding order in the current access unit and the decoding unit associated with the decoding unit information SEI message. This value is also used to calculate an earliest possible time of arrival of decoding unit data into the CPB for the HSS, as specified in Annex C or F.13. The syntax element is represented by a fixed length code whose length in bits is given by `du_cpb_removal_delay_increment_length_minus1 + 1`. When the decoding unit associated with the decoding unit information SEI message is the last decoding unit in the current access unit, the value of `du_spt_cpb_removal_delay_increment` shall be equal to 0.

dpb_output_du_delay_present_flag equal to 1 specifies the presence of the `pic_spt_dpb_output_du_delay` syntax element in the decoding unit information SEI message. `dpb_output_du_delay_present_flag` equal to 0 specifies the absence of the `pic_spt_dpb_output_du_delay` syntax element in the decoding unit information SEI message.

pic_spt_dpb_output_du_delay is used to compute the DPB output time of the picture when `SubPicHrdFlag` is equal to 1. It specifies how many sub clock ticks to wait after removal of the last decoding unit in an access unit from the CPB before the decoded picture is output from the DPB. When not present, the value of `pic_spt_dpb_output_du_delay` is inferred to be equal to `pic_dpb_output_du_delay`.

The length of the syntax element `pic_spt_dpb_output_du_delay` is given in bits by `dpb_output_delay_du_length_minus1 + 1`.

When the buffering period SEI message is non-nested or is directly contained in a scalable nesting SEI message within an SEI NAL unit with `nuh_layer_id` equal to 0, it is a requirement of bitstream conformance that all decoding unit information SEI messages that are associated with the same access unit, apply to the same operation point, and have `dpb_output_du_delay_present_flag` equal to 1 shall have the same value of `pic_spt_dpb_output_du_delay`.

The output time derived from the `pic_spt_dpb_output_du_delay` of any picture that is output from an output timing conforming decoder shall precede the output time derived from the `pic_spt_dpb_output_du_delay` of all pictures in any subsequent CVS in decoding order.

The picture output order established by the values of this syntax element shall be the same order as established by the values of `PicOrderCntVal`.

For pictures that are not output by the "bumping" process because they precede, in decoding order, an IRAP picture with NoRaslOutputFlag equal to 1 that has no_output_of_prior_pics_flag equal to 1 or inferred to be equal to 1, the output times derived from pic_spt_dpb_output_du_delay shall be increasing with increasing value of PicOrderCntVal relative to all pictures within the same CVS.

For any two pictures in the CVS, the difference between the output times of the two pictures when SubPicHrdFlag is equal to 1 shall be identical to the same difference when SubPicHrdFlag is equal to 0.

D.3.23 Temporal sub-layer zero index SEI message semantics

The temporal sub-layer zero index SEI message provides information that can assist the decoder for detection of missing coded pictures that have TemporalId equal to 0 and are not RASL, RADL, or SLNR pictures.

When a temporal sub-layer zero index SEI message is present in the current access unit and applies to the current layer and the current picture is not an IRAP picture, a temporal sub-layer zero index SEI message that applies to the current layer shall also be present in the preceding access unit in decoding order with TemporalId equal to 0 and containing a picture that is not a RASL, RADL, or SLNR picture in the current layer.

NOTE 1 Encoders are expected to be cautious when setting discardable_flag equal to 1 for any picture with TemporalId equal to 0, as based on temporal sub-layer zero index SEI messages decoders can consider intentionally discarded pictures with TemporalId equal to 0 and discardable flag equal to 1 as lost and take unnecessary error recovery actions, such as requesting retransmission of a missing picture with TemporalId equal to 0.

Let ReferencedTsl0Pic denote a picture that has TemporalId equal to 0 and is not RASL, RADL, or SLNR picture.

temporal_sub_layer_zero_idx indicates a temporal sub-layer zero index as follows:

- If the current picture is a ReferencedTsl0Pic, temporal_sub_layer_zero_idx indicates the temporal sub-layer zero index for the current picture.
- Otherwise, temporal_sub_layer_zero_idx indicates the temporal sub-layer zero index of the preceding picture in the current layer in decoding order that is a ReferencedTsl0Pic.

When the bitstream contains a preceding access unit in decoding order that contained a ReferencedTsl0Pic, and that preceding access unit has an associated temporal sub-layer zero index SEI message seiMsgB that applies to the current layer, the variable prevTsl0Idx is set equal to the value of temporal_sub_layer_zero_idx of seiMsgB.

The following constraints apply to the value of temporal_sub_layer_zero_idx:

- If the current picture is an IRAP picture, temporal_sub_layer_zero_idx shall be equal to 0.
- Otherwise, the following apply:
 - If the current picture is a ReferencedTsl0Pic, temporal_sub_layer_zero_idx shall be equal to $(\text{prevTsl0Idx} + 1) \% 256$.
 - Otherwise, temporal_sub_layer_zero_idx shall be equal to prevTsl0Idx.

irap_pic_id is an IRAP picture identifier for the current layer. When the current picture is not the first picture in the current layer in the bitstream in decoding order and the preceding IRAP picture in the current layer in decoding order has an associated temporal sub-layer zero index SEI message, the following constraints apply to the value of irap_pic_id:

- If the current picture is an IRAP picture, irap_pic_id shall differ in value from the value of irap_pic_id of the temporal sub-layer zero index SEI message of the preceding IRAP picture in the current layer in decoding order.

NOTE 2 It is suggested for the value of `irap_pic_id` to be set to a random value (subject to the constraints specified herein), to minimize the likelihood of duplicate values appearing in a layer in the bitstream due to picture losses or splicing operations.

- Otherwise, `irap_pic_id` shall be equal to the value of `irap_pic_id` of the temporal sub-layer zero index SEI message associated with the preceding IRAP picture in the current layer in decoding order.

D.3.24 Scalable nesting SEI message semantics

The scalable nesting SEI message provides a mechanism to associate SEI messages with bitstream subsets corresponding to various operation points or with specific layers or sub-layers.

A scalable nesting SEI message contains one or more SEI messages.

NOTE A scalable nesting SEI message can only be the last SEI message in the SEI NAL unit containing the scalable nesting SEI message. The `sei_payload()` of the scalable nesting SEI message cannot contain any `reserved_payload_extension_data`.

It is a requirement of bitstream conformance that the following restrictions apply on nesting of SEI messages:

- An SEI message that has `payloadType` equal to 129 (active parameter sets), 132 (decoded picture hash), or 133 (scalable nesting) shall not be nested in a scalable nesting SEI message.
- When a scalable nesting SEI message contains a buffering period SEI message, a picture timing SEI message, or a decoding unit information SEI message, the scalable nesting SEI message shall not contain any other SEI message with `payloadType` not equal to 0 (buffering period), 1 (picture timing), or 130 (decoding unit information).

bitstream_subset_flag equal to 0 specifies that the SEI messages contained in the scalable nesting SEI message apply to specific layers or sub-layers. **bitstream_subset_flag** equal to 1 specifies that the SEI messages contained in the scalable nesting SEI message apply to one or more sub-bitstreams as specified below.

Depending on the value of **bitstream_subset_flag**, the layers or sub-layers, or the operation points to which the SEI messages contained in the scalable nesting SEI message apply are specified by deriving the lists `nestingLayerIdList[i]` and the variables `MaxTemporalId[i]` based on syntax element values as specified below.

It is a requirement of bitstream conformance that the following restrictions apply on the value of **bitstream_subset_flag**:

- When the scalable nesting SEI message contains a buffering period SEI message, a picture timing SEI message, or a decoding unit information SEI message, **bitstream_subset_flag** shall be equal to 1.
- When the scalable nesting SEI message contains an SEI message that has `payloadType` equal to any value among `SingleLayerSeiList`, **bitstream_subset_flag** shall be equal to 0.

nesting_op_flag equal to 0 specifies that the list `nestingLayerIdList[0]` is specified by `all_layers_flag` and, when present, `nesting_layer_id[i]` for all `i` values in the range of 0 to `nesting_num_layers_minus1`, inclusive, and that the variable `MaxTemporalId[0]` is specified by `nesting_no_op_max_temporal_id_plus1`. **nesting_op_flag** equal to 1 specifies that the list `nestingLayerIdList[i]` and the variable `MaxTemporalId[i]` are specified by `nesting_num_ops_minus1`, `default_op_flag`, `nesting_max_temporal_id_plus1[i]`, when present, and `nesting_op_idx[i]`, when present.

default_op_flag equal to 1 specifies that `MaxTemporalId[0]` is equal to `nuh_temporal_id_plus1` of the current SEI NAL unit minus 1 and that `nestingLayerIdList[0]` contains all integer values in the range of 0 to `nuh_layer_id` of the current SEI NAL unit, inclusive, in increasing order of the values.

ISO/IEC 23008-2:2017(E)

nesting_num_ops_minus1 plus 1 minus **default_op_flag** specifies the number of the following **nesting_op_idx[i]** syntax elements. The value of **nesting_num_ops_minus1** shall be in the range of 0 to 1023, inclusive.

If **nesting_op_flag** is equal to 0, the variable **nestingNumOps** is set equal to 1. Otherwise, the variable **nestingNumOps** is set equal to **nesting_num_ops_minus1** + 1.

nesting_max_temporal_id_plus1[i] is used to specify the variable **MaxTemporalId[i]**. The value of **nesting_max_temporal_id_plus1[i]** shall be greater than or equal to **nuh_temporal_id_plus1** of the current SEI NAL unit. The variable **MaxTemporalId[i]** is set equal to **nesting_max_temporal_id_plus1[i]** - 1.

nesting_op_idx[i] is used to specify the list **nestingLayerIdList[i]**. The value of **nesting_op_idx[i]** shall be in the range of 0 to 1023, inclusive.

The list **nestingLayerIdList[i]** is set equal to the **OpLayerIdList** of the **nesting_op_idx[i]**-th layer set specified by the active VPS.

It is a requirement of bitstream conformance that when **nesting_op_flag** is equal to 1 and **nesting_op_idx[i]** is greater than **vps_num_layer_sets_minus1** for any value of **i** in the range of **default_op_flag** to **nesting_num_ops_minus1**, inclusive, the value of **nuh_layer_id** of the SEI NAL unit containing the scalable nesting SEI message shall be greater than 0.

all_layers_flag equal to 0 specifies that the list **nestingLayerIdList[0]** is specified by **nesting_layer_id[i]** for all **i** values in the range of 0 to **nesting_num_layers_minus1**, inclusive. **all_layers_flag** equal to 1 specifies that the list **nestingLayerIdList[0]** consists of all values of **nuh_layer_id** present in the current access unit that are greater than or equal to **nuh_layer_id** of the current SEI NAL unit, in increasing order of the values.

When **nesting_op_flag** is equal to 0 and **all_layers_flag** is equal to 1, **MaxTemporalId[0]** is set equal to 6.

nesting_no_op_max_temporal_id_plus1 minus 1 specifies the value of **MaxTemporalId[0]** when **nesting_op_flag** is equal to 0 and **all_layers_flag** is equal to 0. The value of **nesting_no_op_max_temporal_id_plus1** shall not be equal to 0.

nesting_num_layers_minus1 plus 1 specifies the number of the following **nesting_layer_id[i]** syntax elements. The value of **nesting_num_layers_minus1** shall be in the range of 0 to 63, inclusive.

nesting_layer_id[i] specifies the **i**-th **nuh_layer_id** value included in the list **nestingLayerIdList[0]**.

For any **i** and **j** in the range of 0 to **nesting_num_layers_minus1**, inclusive, with **i** less than **j**, **nesting_layer_id[i]** shall be less than **nesting_layer_id[j]**.

The list **nestingLayerIdList[0]** is set to consist of **nesting_layer_id[i]** for all **i** values in the range of 0 to **nesting_num_layers_minus1**, inclusive, in increasing order of **i** values.

When **bitstream_subset_flag** is equal to 0, the following apply:

- The SEI messages contained in the scalable nesting SEI message apply to the sets of layers or sub-layers **subLayerSet[i]** for all **i** values in the range of 0 to **nestingNumOps** - 1, inclusive, where the VCL NAL units of the layers or sub-layers in each set **subLayerSet[i]** have **nuh_layer_id** values that are included in the list **nestingLayerIdList[i]** and **TemporalId** values that are in the range of the **TemporalId** of the current SEI NAL unit to **MaxTemporalId[i]**, inclusive.
- When a nested SEI message has **payloadType** equal to any value among **VclAssociatedSeiList**, the value of **TemporalId** of the SEI NAL unit containing the scalable nesting SEI message shall be equal to 0 and **MaxTemporalId[i]** for all values of **i** in the range of 0 to **nestingNumOps** - 1, inclusive, shall be equal to 6.
- When a nested SEI message has **payloadType** equal to any value among **VclAssociatedSeiList** and the value of **nestingNumOps** is greater than 0, the nested SEI message applies to all layers for which

each `nuh_layer_id` is included in at least one of the lists `nestingLayerIdList[i]` with `i` ranging from 0 to `nestingNumOps - 1`, inclusive.

When `bitstream_subset_flag` is equal to 1, the SEI messages contained in the scalable nesting SEI message apply to the operation points corresponding to the sub-bitstreams `subBitstream[i]` for all `i` values in the range of 0 to `nestingNumOps - 1`, inclusive, where each sub-bitstream `subBitstream[i]` is derived as follows:

- If `nestingLayerIdList[i][0]` is equal to 0 and `vps_base_layer_internal_flag` is equal to 1, the sub-bitstream `subBitstream[i]` is the output of the sub-bitstream extraction process of Clause 10 with the bitstream, `MaxTemporalId[i]`, and `nestingLayerIdList[i]` as inputs.
- Otherwise, if `nestingLayerIdList[i][0]` is equal to 0 and `vps_base_layer_internal_flag` is equal to 0, the sub-bitstream `subBitstream[i]` is the output of the sub-bitstream extraction process of F.10.1 with the bitstream, `MaxTemporalId[i]`, and `nestingLayerIdList[i]` as inputs.
- Otherwise, the sub-bitstream `subBitstream[i]` is the output of the sub-bitstream extraction process of F.10.3 with the bitstream, `MaxTemporalId[i]`, and `nestingLayerIdList[i]` as inputs.

`nesting_zero_bit` shall be equal to 0.

D.3.25 Region refresh information SEI message semantics

The region refresh information SEI message indicates whether the slice segments that the current SEI message applies to belong to a refreshed region of the current picture (as defined below).

An access unit that is not an IRAP access unit and that contains a recovery point SEI message is referred to as a gradual decoding refresh (GDR) access unit, and its corresponding picture is referred to as a GDR picture. The access unit corresponding to the indicated recovery point picture is referred to as the recovery point access unit.

If there is a picture that follows the GDR picture in decoding order in the CVS and that has `PicOrderCntVal` equal to the `PicOrderCntVal` of the GDR picture plus the value of `recovery_poc_cnt` in the recovery point SEI message, let the variable `lastPicInSet` be the recovery point picture. Otherwise, let `lastPicInSet` be the picture that immediately precedes the recovery point picture in output order. The picture `lastPicInSet` shall not precede the GDR picture in decoding order.

Let `gdrPicSet` be the set of pictures starting from a GDR picture to the picture `lastPicInSet`, inclusive, in output order. When the decoding process is started from a GDR access unit, the refreshed region in each picture of the `gdrPicSet` is indicated to be the region of the picture that is correct or approximately correct in content, and, when `lastPicInSet` is the recovery point picture, the refreshed region in `lastPicInSet` covers the entire picture.

The slice segments to which a region refresh information SEI message applies consist of all slice segments within the access unit that follow the SEI NAL unit containing the region refresh information SEI message and precede the next SEI NAL unit containing a region refresh information SEI message (if any) in decoding order. These slice segments are referred to as the slice segments associated with the region refresh information SEI message.

Let `gdrAuSet` be the set of access units corresponding to `gdrPicSet`. A `gdrAuSet` and the corresponding `gdrPicSet` are referred to as being associated with the recovery point SEI message contained in the GDR access unit.

Region refresh information SEI messages shall not be present in an access unit unless the access unit is included in a `gdrAuSet` associated with a recovery point SEI message. When any access unit that is included in a `gdrAuSet` contains one or more region refresh information SEI messages, all access units in the `gdrAuSet` shall contain one or more region refresh information SEI messages.

`refreshed_region_flag` equal to 1 indicates that the slice segments associated with the current SEI message belong to the refreshed region in the current picture. `refreshed_region_flag` equal to 0

indicates that the slice segments associated with the current SEI message may not belong to the refreshed region in the current picture.

When one or more region refresh information SEI messages are present in an access unit and the first slice segment of the access unit in decoding order does not have an associated region refresh information SEI message, the value of `refreshed_region_flag` for the slice segments that precede the first region refresh information SEI message is inferred to be equal to 0.

When `lastPicInSet` is the recovery point picture, and any region refresh SEI message is included in a recovery point access unit, the first slice segment of the access unit in decoding order shall have an associated region refresh SEI message, and the value of `refreshed_region_flag` shall be equal to 1 in all region refresh SEI messages in the access unit.

When one or more region refresh information SEI messages are present in an access unit, the refreshed region in the picture is specified as the set of CTUs in all slice segments of the access unit that are associated with region refresh information SEI messages that have `refreshed_region_flag` equal to 1. Other slice segments belong to the non-refreshed region of the picture.

It is a requirement of bitstream conformance that when a dependent slice segment belongs to the refreshed region, the preceding slice segment in decoding order shall also belong to the refreshed region.

Let `gdrRefreshedSliceSegmentSet` be the set of all slice segments that belong to the refreshed regions in the `gdrPicSet`. When a `gdrAuSet` contains one or more region refresh information SEI messages, it is a requirement of bitstream conformance that the following constraints all apply.

- The refreshed region in the first picture included in the corresponding `gdrPicSet` in decoding order that contains any refreshed region shall contain only coding units that are coded in an intra coding mode.
- For each picture included in the `gdrPicSet`, the syntax elements in `gdrRefreshedSliceSegmentSet` shall be constrained such that no samples or motion vector values outside of `gdrRefreshedSliceSegmentSet` are used for inter prediction in the decoding process of any samples within `gdrRefreshedSliceSegmentSet`.
- For any picture that follows the picture `lastPicInSet` in output order, the syntax elements in the slice segments of the picture shall be constrained such that no samples or motion vector values outside of `gdrRefreshedSliceSegmentSet` are used for inter prediction in the decoding process of the picture other than those of the other pictures that follow the picture `lastPicInSet` in output order.

D.3.26 No display SEI message semantics

The no display SEI message indicates that the current picture should not be displayed.

D.3.27 Time code SEI message semantics

The time code SEI message provides time code information similar to that defined by Society of Motion Picture and Television Engineers ST 12-1 for field(s) or frame(s) of the current picture. When `vps_timing_info_present_flag` is equal to 1, it also defines a time offset for use in calculating a reference clock timestamp from the time code syntax elements to indicate a time of origin, capture, or alternative ideal display.

num_clock_ts specifies the number of sets of clock timestamp syntax elements that may be present for the current picture, the presence of each of which is specified by a syntax flag `clock_timestamp_flag[i]` for a corresponding value of *i*. When `frame_field_info_present_flag` is equal to 1, the *i*-th set of clock timestamp syntax elements applies to the *i*-th field or frame associated with the indicated display of the current picture in the order specified by `pic_struct` in Table D.2. The value of `num_clock_ts` shall not be equal to 0.

When `field_seq_flag` is equal to 1, the value of `num_clock_ts` shall be equal to 1.

When `frame_field_info_present_flag` is equal to 1, the value of `num_clock_ts` shall be equal to the value of `DeltaToDivisor` specified in Table E.6.

When `vps_timing_info_present_flag` is equal to 1, the contents of the clock timestamp syntax elements indicate a time of origin, capture, or alternative ideal display. This indicated time is computed as

$$\text{clockTimestamp}[i] = ((\text{hH} * 60 + \text{mM}) * 60 + \text{sS}) * \text{vui_time_scale} + \text{nFrames} * (\text{vui_num_units_in_tick} * (1 + \text{units_field_based_flag}[i])) + \text{tOffset} \quad (\text{D-26})$$

in units of clock ticks of a clock with clock frequency equal to `vui_time_scale` Hz, relative to some unspecified point in time for which `clockTimestamp[i]` would be equal to 0. Output order and DPB output timing are not affected by the value of `clockTimestamp[i]`. When `frame_field_info_present_flag` is equal to 1 and two or more pictures with `pic_struct` equal to 0 are consecutive in output order and have equal values of `clockTimestamp[i]`, the indication is that the pictures represent the same content and that the last such picture in output order is the preferred representation.

NOTE 1 `clockTimestamp[i]` time indications may aid display on devices with refresh rates other than those well-matched to DPB output times. However, the time code SEI message does not affect the output order and DPB output timing defined in this document.

`clock_timestamp_flag[i]` equal to 1 indicates that associated set of clock timestamp syntax elements are present for the *i*-th set of clock timestamp syntax elements of the current picture. `clock_timestamp_flag[i]` equal to 0 indicates that the associated set of clock timestamp syntax elements is not present. When `vps_timing_info_present_flag` is equal to 1, `num_clock_ts` is greater than 1, and `clock_timestamp_flag[i]` is equal to 1 for more than one value of *i*, the value of `clockTimestamp[i]` shall be non-decreasing with increasing value of *i*.

For the *i*-th set of clock timestamp syntax elements of the current picture, the previous set of clock timestamp syntax elements in decoding order (or in output order, respectively), is defined as follows:

- If *i* is equal to 0, the previous set of clock timestamp syntax elements in decoding order (or in output order, respectively) is the set of syntax elements for the highest value of *i* for the previous picture in decoding order (or in output order, respectively) that contained a time code SEI message.
- Otherwise, the previous set of clock timestamp syntax elements in decoding order (or in output order, respectively) is the (*i* - 1)-th set of clock timestamp syntax elements of the current picture.

`units_field_based_flag[i]` is used in calculating `clockTimestamp[i]`, as specified in Formula (D-26).

NOTE 2 `units_field_based_flag[i]` is expected to be the same for all values of *i* for all pictures in the CVS. When `field_seq_flag` is equal to 1 or `frame_field_info_present_flag` is equal to 1 and `pic_struct` is in the range of 1 to 6 or 9 to 12, inclusive, `units_field_based_flag[i]` is expected to be equal to 1.

`counting_type[i]` specifies the method of dropping values of the `n_frames[i]` syntax element as specified in Table D.11.

NOTE 3 `counting_type[i]` is expected to be the same for all values of *i* for all pictures in the CVS.

Table D.11 — Definition of `counting_type[i]` values

Value	Interpretation
0	no dropping of <code>n_frames[i]</code> count values and no use of <code>time_offset_value[i]</code>
1	no dropping of <code>n_frames[i]</code> count values
2	dropping of individual zero values of <code>n_frames[i]</code> count
3	dropping of individual values of <code>n_frames[i]</code> count equal to <code>MaxFPS - 1</code>

4	dropping of the two lowest (value 0 and 1) $n_frames[i]$ counts when $seconds_value[i]$ is equal to 0 and $minutes_value[i]$ is not an integer multiple of 10
5	dropping of unspecified individual $n_frames[i]$ count values
6	dropping of unspecified numbers of unspecified $n_frames[i]$ count values
7..31	reserved

full_timestamp_flag[i] equal to 1 specifies that the $n_frames[i]$ syntax element is followed by $seconds_value[i]$, $minutes_value[i]$, and $hours_value[i]$. **full_timestamp_flag**[i] equal to 0 specifies that the $n_frames[i]$ syntax element is followed by $seconds_flag[i]$.

discontinuity_flag[i] equal to 0 indicates that the difference between the current value of $clockTimestamp[i]$ and the value of $clockTimestamp[i]$ computed from the previous set of clock timestamp syntax elements in output order can be interpreted as the time difference between the times of origin or capture of the associated frames or fields. **discontinuity_flag**[i] equal to 1 indicates that the difference between the current value of $clockTimestamp[i]$ and the value of $clockTimestamp[i]$ computed from the previous set of clock timestamp syntax elements in output order should not be interpreted as the time difference between the times of origin or capture of the associated frames or fields. When $vps_timing_info_present_flag$ is equal to 1 and **discontinuity_flag**[i] is equal to 0, the value of $clockTimestamp[i]$ shall be greater than or equal to the value of $clockTimestamp[i]$ for the previous set of clock timestamp syntax elements in output order (when present).

cnt_dropped_flag[i] specifies the skipping of one or more values of $n_frames[i]$ using the counting method specified by $counting_type[i]$.

n_frames[i] specifies the value of $nFrames$ used to compute $clockTimestamp[i]$. When $vps_timing_info_present_flag$ is equal to 1, $n_frames[i]$ shall be less than $MaxFPS$, where $MaxFPS$ is specified by

$$MaxFPS = Ceil(vui_time_scale \div ((1 + units_field_based_flag[i]) * vui_num_units_in_tick)) \quad (D-27)$$

NOTE 4 $n_frames[i]$ is a frame-based counter. To provide field-specific timing indications when the current picture is a frame, $time_offset_value[i]$ is expected to be used to indicate a distinct $clockTimestamp[i]$ for each field of the frame.

When $counting_type[i]$ is equal to 2 and **cnt_dropped_flag**[i] is equal to 1, $n_frames[i]$ shall be equal to 1 and the value of $n_frames[i]$ for the previous set of clock timestamp syntax elements in output order (when present) shall not be equal to 0 unless **discontinuity_flag**[i] is equal to 1.

NOTE 5 When $counting_type[i]$ is equal to 2, the need for increasingly large magnitudes of $tOffset$ in Formula (D-26) when using fixed non-integer frame rates (e.g. 12.5 frames per second with vui_time_scale equal to 50 and $vui_num_units_in_tick$ equal to 2 and $units_field_based_flag[i]$ equal to 0) can be avoided by occasionally skipping over the value $n_frames[i]$ equal to 0 when counting (e.g. counting $n_frames[i]$ from 0 to 12, then incrementing $seconds_value[i]$ and counting $n_frames[i]$ from 1 to 12, then incrementing $seconds_value[i]$ and counting $n_frames[i]$ from 0 to 12, etc.).

When $vps_timing_info_present_flag$ is equal to 1, $counting_type[i]$ is equal to 3, and **cnt_dropped_flag**[i] is equal to 1, $n_frames[i]$ shall be equal to 0 and the value of $n_frames[i]$ for the previous set of clock timestamp syntax elements in output order (when present) shall not be equal to $MaxFPS - 1$ unless **discontinuity_flag**[i] is equal to 1.

NOTE 6 When $counting_type[i]$ is equal to 3, the need for increasingly large magnitudes of $tOffset$ in Formula (D-26) when using fixed non-integer frame rates (e.g. 12.5 frames per second with vui_time_scale equal to 50 and $vui_num_units_in_tick$ equal to 2 and $units_field_based_flag[i]$ equal to 0) can be avoided by occasionally skipping over the value $n_frames[i]$ equal to $MaxFPS - 1$ when counting (e.g. counting $n_frames[i]$ from 0 to 12, then incrementing $seconds_value[i]$ and counting $n_frames[i]$ from 0 to 11, then incrementing $seconds_value[i]$ and counting $n_frames[i]$ from 0 to 12, etc.).

When `counting_type[i]` is equal to 4 and `cnt_dropped_flag[i]` is equal to 1, `n_frames[i]` shall be equal to 2 and `seconds_value[i]` shall be equal to zero and `minutes_value[i]` shall not be an integer multiple of 10 and `n_frames[i]` for the previous set of clock timestamp syntax elements in output order (when present) shall not be equal to 0 or 1 unless `discontinuity_flag[i]` is equal to 1.

NOTE 7 When `counting_type[i]` is equal to 4, the need for increasingly large magnitudes of `tOffset` in Formula (D-26) when using fixed non-integer frame rates (e.g. 30000÷1001 frames per second with `vui_time_scale` equal to 60000 and `vui_num_units_in_tick` equal to 1 001 and `units_field_based_flag[i]` equal to 1) can be reduced by occasionally skipping over the values of `n_frames[i]` equal to 0 and 1 when counting (e.g. counting `n_frames[i]` from 0 to 29, then incrementing `seconds_value[i]` and counting `n_frames[i]` from 0 to 29, etc., until the `seconds_value[i]` is zero and `minutes_value[i]` is not an integer multiple of ten, then counting `n_frames[i]` from 2 to 29, then incrementing `seconds_value[i]` and counting `n_frames[i]` from 0 to 29, etc.). This counting method is well known in the industry and is often referred to as "NTSC drop-frame" counting.

When `vps_timing_info_present_flag` is equal to 1, `counting_type[i]` is equal to 5 or 6, and `cnt_dropped_flag[i]` is equal to 1, `n_frames[i]` shall not be equal to 1 plus the value of `n_frames[i]` for the previous set of clock timestamp syntax elements in output order (when present) modulo `MaxFPS` unless `discontinuity_flag[i]` is equal to 1.

NOTE 8 When `counting_type[i]` is equal to 5 or 6, the need for increasingly large magnitudes of `tOffset` in Formula (D-26) when using fixed non-integer frame rates can be avoided by occasionally skipping over some values of `n_frames[i]` when counting. The specific values of `n_frames[i]` that are skipped are not specified when `counting_type[i]` is equal to 5 or 6.

seconds_flag[i] equal to 1 specifies that `seconds_value[i]` and `minutes_flag[i]` are present when `full_timestamp_flag[i]` is equal to 0. `seconds_flag[i]` equal to 0 specifies that `seconds_value[i]` and `minutes_flag[i]` are not present.

seconds_value[i] specifies the value of `sS` used to compute `clockTimestamp[i]`. The value of `seconds_value[i]` shall be in the range of 0 to 59, inclusive. When `seconds_value[i]` is not present, its value is inferred to be equal to the value of `seconds_value[i]` for the previous set of clock timestamp syntax elements in decoding order, and it is required that such a previous `seconds_value[i]` shall have been present.

minutes_flag[i] equal to 1 specifies that `minutes_value[i]` and `hours_flag[i]` are present when `full_timestamp_flag[i]` is equal to 0 and `seconds_flag[i]` is equal to 1. `minutes_flag[i]` equal to 0 specifies that `minutes_value[i]` and `hours_flag[i]` are not present.

minutes_value[i] specifies the value of `mM` used to compute `clockTimestamp[i]`. The value of `minutes_value[i]` shall be in the range of 0 to 59, inclusive. When `minutes_value[i]` is not present, its value is inferred to be equal to the value of `minutes_value[i]` for the previous set of clock timestamp syntax elements in decoding order, and it is required that such a previous `minutes_value[i]` shall have been present.

hours_flag[i] equal to 1 specifies that `hours_value[i]` is present when `full_timestamp_flag[i]` is equal to 0 and `seconds_flag[i]` is equal to 1 and `minutes_flag[i]` is equal to 1.

hours_value[i] specifies the value of `hH` used to compute `clockTimestamp[i]`. The value of `hours_value[i]` shall be in the range of 0 to 23, inclusive. When `hours_value[i]` is not present, its value is inferred to be equal to the value of `hours_value[i]` for the previous set of clock timestamp syntax elements in decoding order, and it is required that such a previous `hours_value[i]` shall have been present.

time_offset_length[i] greater than 0 specifies the length in bits of the `time_offset_value[i]` syntax element. `time_offset_length[i]` equal to 0 specifies that the `time_offset_value[i]` syntax element is not present. When `counting_type[i]` is equal to 0, `time_offset_length[i]` shall be equal to 0.

NOTE 9 `time_offset_length[i]` is expected to be the same for all values of `i` for all pictures in the CVS.

time_offset_value[*i*] specifies the value of `tOffset` used to compute `clockTimestamp`[*i*]. The number of bits used to represent `time_offset_value`[*i*] is equal to `time_offset_length`[*i*]. When `time_offset_value`[*i*] is not present, its value is inferred to be equal to 0.

D.3.28 Mastering display colour volume SEI message semantics

This SEI message identifies the colour volume (the colour primaries, white point, and luminance range) of a display considered to be the mastering display for the associated video content – e.g. the colour volume of a display that was used for viewing while authoring the video content. The described mastering display is a three-colour additive display system that has been configured to use the indicated mastering colour volume.

This SEI message does not specify the measurement methodologies and procedures used for determining the indicated values or any description of the mastering environment. It also does not provide information on colour transformations that would be appropriate to preserve creative intent on displays with colour volumes different from that of the described mastering display.

The information conveyed in this SEI message is intended to be adequate for purposes corresponding to the use of Society of Motion Picture and Television Engineers ST 2086.

When a mastering display colour volume SEI message is present for any picture of a CLVS of a particular layer, a mastering display colour volume SEI message shall be present for the first picture of the CLVS. The mastering display colour volume SEI message persists for the current layer in decoding order from the current picture until the end of the CLVS. All mastering display colour volume SEI messages that apply to the same CLVS shall have the same content.

display_primaries_x[*c*] and **display_primaries_y**[*c*] specify the normalized *x* and *y* chromaticity coordinates, respectively, of the colour primary component *c* of the mastering display in increments of 0.00002, according to the CIE 1931 definition of *x* and *y* as specified in ISO 11664-1 (see also ISO 11664-3 and CIE 15). For describing mastering displays that use red, green, and blue colour primaries, it is suggested that index value *c* equal to 0 should correspond to the green primary, *c* equal to 1 should correspond to the blue primary, and *c* equal to 2 should correspond to the red colour primary (see also Annex E and Table E.3). The values of `display_primaries_x`[*c*] and `display_primaries_y`[*c*] shall be in the range of 0 to 50 000, inclusive.

white_point_x and **white_point_y** specify the normalized *x* and *y* chromaticity coordinates, respectively, of the white point of the mastering display in normalized increments of 0.00002, according to the CIE 1931 definition of *x* and *y* as specified in ISO 11664-1 (see also ISO 11664-3 and CIE 15). The values of `white_point_x` and `white_point_y` shall be in the range of 0 to 50 000.

max_display_mastering_luminance and **min_display_mastering_luminance** specify the nominal maximum and minimum display luminance, respectively, of the mastering display in units of 0.0001 candelas per square metre. `min_display_mastering_luminance` shall be less than `max_display_mastering_luminance`.

At minimum luminance, the mastering display is considered to have the same nominal chromaticity as the white point.

D.3.29 Segmented rectangular frame packing arrangement SEI message semantics

This SEI message informs the decoder that the output cropped decoded picture contains samples of multiple distinct spatially packed constituent frames that are packed into one frame using a rectangular region frame packing arrangement. This information can be used by the decoder to appropriately rearrange the samples and process the samples of the constituent frames appropriately for display or other purposes (which are outside the scope of this document).

Each component plane of the decoded frames contains a rectangular region frame packing arrangement of corresponding planes of two constituent frames as illustrated in Figure D.10.

NOTE 1 Figure D.10 provides an illustration of the rearrangement process for the rectangular region frame packing arrangement.

This SEI message may be associated with pictures that are either frames (when `field_seq_flag` is equal to 0) or fields (when `field_seq_flag` is equal to 1). The rectangular region frame packing arrangement of the samples is specified in terms of the sampling structure of a frame in order to define a frame packing arrangement structure that is invariant with respect to whether a picture is a single field of such a packed frame or is a complete packed frame.

When `general_non_packed_constraint_flag` is equal to 1 in the active SPS for the current layer, there shall be no segmented rectangular frame packing arrangement SEI messages applicable for any picture of the CLVS of the current layer.

When a frame packing arrangement SEI message is applicable for any picture of the CLVS of the current layer, there shall be no segmented rectangular frame packing arrangement SEI messages applicable for any picture of the CLVS of the current layer.

`segmented_rect_frame_packing_arrangement_cancel_flag` equal to 1 indicates that the segmented rectangular frame packing arrangement SEI message cancels the persistence of any previous segmented rectangular frame packing arrangement SEI message in output order. `segmented_rect_frame_packing_arrangement_cancel_flag` equal to 0 indicates that rectangular region frame packing arrangement information follows.

`segmented_rect_content_interpretation_type` indicates the intended interpretation of the constituent frames as specified in Table D.12. Values of `segmented_rect_content_interpretation_type` that do not appear in Table D.12 are reserved for future specification by ITU-T | ISO/IEC and shall not be present in bitstreams conforming to this version of this document. Decoders shall ignore rectangular region frame packing arrangement SEI messages that contain reserved values of `segmented_rect_content_interpretation_type`.

For the specified frame packing arrangement scheme, there are two constituent frames that are referred to as frame 0 and frame 1.

Table D.12 — Definition of `segmented_rect_content_interpretation_type`

Value	Interpretation
0	Unspecified relationship between the frame packed constituent frames
1	Indicates that the two constituent frames form the left and right views of a stereo view scene, with frame 0 being associated with the left view and frame 1 being associated with the right view
2	Indicates that the two constituent frames form the right and left views of a stereo view scene, with frame 0 being associated with the right view and frame 1 being associated with the left view

NOTE 2 The value 2 for `segmented_rect_content_interpretation_type` is not expected to be prevalent in industry use of this SEI message. However, the value was specified herein for purposes of completeness.

`segmented_rect_frame_packing_arrangement_persistence_flag` specifies the persistence of the segmented rectangular frame packing arrangement SEI message for the current layer.

`segmented_rect_frame_packing_arrangement_persistence_flag` equal to 0 specifies that the rectangular region frame packing arrangement SEI message applies to the current decoded frame only.

Let `picA` be the current picture. `segmented_rect_frame_packing_arrangement_persistence_flag` equal to 1 specifies that the segmented rectangular frame packing arrangement SEI message persists for the current layer in output order until any of the following conditions are true:

- A new CLVS of the current layer begins.
- The bitstream ends.
- A frame `picB` in the current layer in an access unit containing a segmented rectangular frame packing arrangement SEI message applicable to the current layer is output for which `PicOrderCnt(picB)` is greater than `PicOrderCnt(picA)`, where `PicOrderCnt(picB)` and

ISO/IEC 23008-2:2017(E)

PicOrderCnt(picA) are the PicOrderCntVal values of picB and picA, respectively, immediately after the invocation of the decoding process for picture order count for picB.

NOTE 3 The default display window parameters in the VUI parameters of the SPS are expected to be used by an encoder to indicate to a decoder that does not interpret the rectangular region frame packing arrangement SEI message that the default display window is an area within only one of the two constituent frames.

Let croppedWidth and croppedHeight be the width and height, respectively, of the cropped frame output from the decoder in units of luma samples, derived as follows:

$$\text{croppedWidth} = \text{pic_width_in_luma_samples} - \text{SubWidthC} * (\text{conf_win_right_offset} + \text{conf_win_left_offset}) \quad (\text{D-28})$$

$$\text{croppedHeight} = \text{pic_height_in_luma_samples} - \text{SubHeightC} * (\text{conf_win_bottom_offset} + \text{conf_win_top_offset}) \quad (\text{D-29})$$

It is a requirement of bitstream conformance for the rectangular region frame packing arrangement that croppedWidth and croppedHeight shall be integer multiples of 3.

Let oneThirdWidth and oneThirdHeight be derived as follows:

$$\text{oneThirdWidth} = \text{croppedWidth} / 3 \quad (\text{D-30})$$

$$\text{oneThirdHeight} = \text{croppedHeight} / 3 \quad (\text{D-31})$$

The rectangular region frame packing arrangement is composed of five rectangular regions identified as R0, R1, R2, R3, and R4 as illustrated in Figure D.10.

The width and height of the region R0 are specified in units of frame luma samples as follows:

$$r0_w = 2 * \text{oneThirdWidth} \quad (\text{D-32})$$

$$r0_H = 2 * \text{oneThirdHeight} \quad (\text{D-33})$$

The width and height of the region R1 are specified in units of frame luma samples as follows:

$$r1_w = \text{oneThirdWidth} \quad (\text{D-34})$$

$$r1_H = 2 * \text{oneThirdHeight} \quad (\text{D-35})$$

The width and height of the region R2 are specified in units of frame luma samples as follows:

$$r2_w = \text{oneThirdWidth} \quad (\text{D-36})$$

$$r2_H = \text{oneThirdHeight} \quad (\text{D-37})$$

The width and height of the region R3 are specified in units of frame luma samples as follows:

$$r3_w = \text{oneThirdWidth} \quad (\text{D-38})$$

$$r3_H = \text{oneThirdHeight} \quad (\text{D-39})$$

The width and height of the region R4 are specified in units of frame luma samples as follows:

$$r4_w = \text{oneThirdWidth} \quad (\text{D-40})$$

$$r4_H = \text{oneThirdHeight} \quad (\text{D-41})$$

Constituent frame 0 is obtained by cropping from the decoded frames the region R0, and constituent frame 1 is obtained by stacking vertically the regions R2 and R3 and placing the resulting rectangle to the right of the region R1. The region R4 is not part of either constituent frame and is discarded.

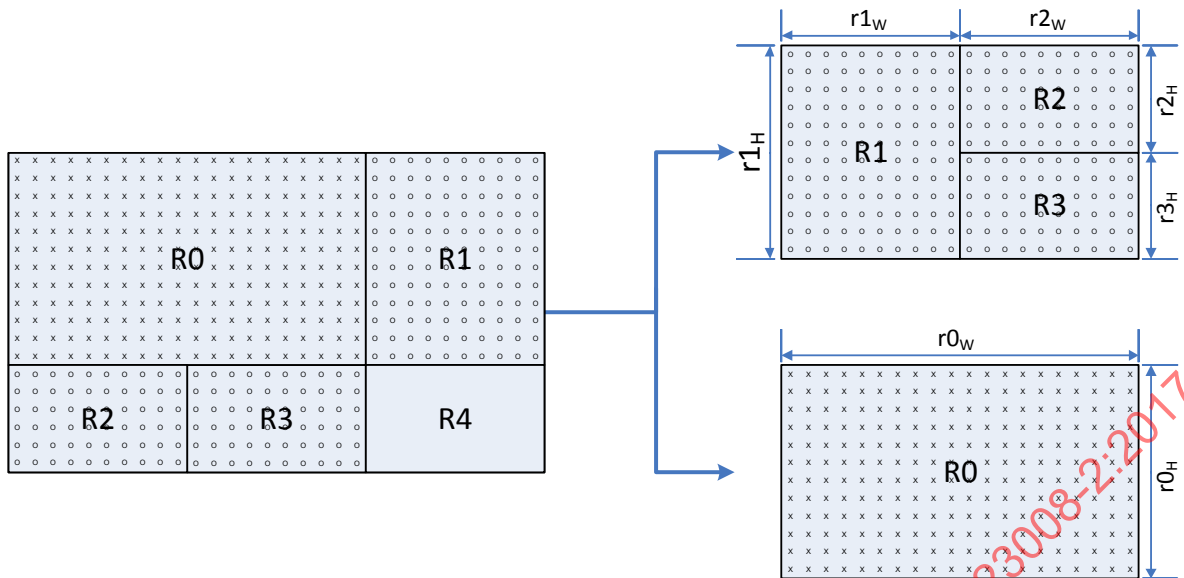

Figure D.10 — Rearrangement of a segmented rectangular frame packing arrangement

D.3.30 Temporal motion-constrained tile sets SEI message semantics

The temporal motion-constrained tile sets SEI message indicates that the inter prediction process is constrained such that no sample value outside each identified tile set, and no sample value at a fractional sample position that is derived using one or more sample values outside the identified tile set, is used for inter prediction of any sample within the identified tile set.

Let a set of pictures associatedPicSet be the pictures with nuh_layer_id equal to targetLayerId from the access unit containing the SEI message, inclusive up to but not including the first of any of the following in decoding order:

- The next access unit, in decoding order, that contains a temporal motion-constrained tile sets SEI message applicable to targetLayerId.
- The next IRAP picture with NoRaslOutputFlag equal to 1, in decoding order, with nuh_layer_id equal to targetLayerId.
- The next IRAP access unit, in decoding order, with NoClrasOutputFlag equal to 1.

The scope of the temporal motion-constrained tile sets SEI message is the set of pictures associatedPicSet.

When a temporal motion-constrained tile sets SEI message is present for any picture in associatedPicSet, a temporal motion-constrained tile sets SEI message applicable to targetLayerId shall be present for the first picture of associatedPicSet in decoding order and may also be present for other pictures of associatedPicSet.

The temporal motion-constrained tile sets SEI message applicable to targetLayerId shall not be present for any picture in associatedPicSet when tiles_enabled_flag is equal to 0 for any PPS that is active for any picture in associatedPicSet.

The temporal motion-constrained tile sets SEI message applicable to targetLayerId shall not be present for any picture in associatedPicSet unless every PPS that is active for any picture in associatedPicSet has the same values of the syntax elements num_tile_columns_minus1, num_tile_rows_minus1, uniform_spacing_flag, column_width_minus1[i], and row_height_minus1[i].

ISO/IEC 23008-2:2017(E)

NOTE 1 This constraint is similar to the constraint associated with `tiles_fixed_structure_flag` equal to 1, and it may be desirable for `tiles_fixed_structure_flag` to be equal to 1 when the temporal motion-constrained tile sets SEI message is present (although this is not required).

NOTE 2 When loop filtering is applied across tile boundaries, inter prediction of any samples within a temporal motion-constrained tile set that refers to samples within four samples from a temporal motion-constrained tile set boundary that is not also a picture boundary may result in propagation of mismatch error. An encoder can avoid such potential error propagation by avoiding the use of motion vectors that cause such references.

When more than one temporal motion-constrained tile sets SEI message applicable to `targetLayerId` is present for the pictures of associated `PicSet`, they shall contain identical content.

The number of temporal motion-constrained tile sets SEI messages applicable to the same `nuh_layer_id` value in each access unit shall not exceed 5.

`mc_all_tiles_exact_sample_value_match_flag` equal to 0 indicates that when the coding tree units that do not belong to any tile in the motion-constrained tile sets are not decoded and the boundaries of the tiles in the motion-constrained tile sets are treated as picture boundaries for purposes of the decoding process, the decoded value of each sample in the tiles in the motion-constrained tile sets may not be exactly the same as the decoded value of the same sample when all the coding tree units of the picture are decoded. **`mc_all_tiles_exact_sample_value_match_flag`** equal to 1 indicates that when the coding tree units that do not belong to any tile in the motion-constrained tile sets are not decoded and the boundaries of the tiles in the motion-constrained tile sets are treated as picture boundaries for purposes of the decoding process, the decoded value of each sample in the tiles in the motion-constrained tile sets is exactly the same as the decoded value of the sample that would be obtained when all the coding tree units of all pictures in `associatedPicSet` are decoded.

`each_tile_one_tile_set_flag` equal to 1 indicates that each and every tile in the picture is included in a separate temporal motion-constrained tile set. **`each_tile_one_tile_set_flag`** equal to 0 indicates that such constraint may not be applied.

`limited_tile_set_display_flag` equal to 1 specifies that the `display_tile_set_flag[i]` syntax element is present and indicates that the tiles not included within any tile set with `display_tile_set_flag[i]` equal to 1 are not intended for display. **`limited_tile_set_display_flag`** equal to 0 specifies that the `display_tile_set_flag[i]` syntax element is not present.

`num_sets_in_message_minus1` plus 1 specifies the number of temporal motion-constrained tile sets identified in the SEI message. The value of `num_sets_in_message_minus1` shall be in the range of 0 to 255, inclusive.

`mcts_id[i]` contains an identifying number that may be used to identify the purpose of the *i*-th identified tile set (for example, to identify an area to be extracted from `associatedPicSet` for a particular purpose). The value of `mcts_id[i]` shall be in the range of 0 to $2^{32} - 2$, inclusive.

Values of `mcts_id[i]` from 0 to 255, inclusive, and from 512 to $2^{31} - 1$, inclusive, may be used as determined by the application. Values of `mcts_id[i]` from 256 to 511, inclusive, and from 2^{31} to $2^{32} - 2$, inclusive, are reserved for future use by ITU-T | ISO/IEC, and bitstreams shall not contain such values. Decoders shall ignore (remove from the bitstream and discard) those SEI messages containing a value of `mcts_id[i]` in the range of 256 to 511, inclusive, or in the range of 2^{31} to $2^{32} - 2$, inclusive.

`display_tile_set_flag[i]` equal to 1 indicates that the *i*-th tile set is intended for display. **`display_tile_set_flag[i]`** equal to 0 indicates that the *i*-th tile set is not intended for display. When not present, the value of `display_tile_set_flag[i]` is inferred to be equal to 1.

`num_tile_rects_in_set_minus1[i]` plus 1 specifies the number of rectangular regions of tiles in the *i*-th identified temporal motion-constrained tile set. The value of `num_tile_rects_in_set_minus1[i]` shall be in the range of 0 to $(\text{num_tile_columns_minus1} + 1) * (\text{num_tile_rows_minus1} + 1) - 1$, inclusive.

`top_left_tile_index[i][j]` and **`bottom_right_tile_index[i][j]`** identify the tile position of the top-left tile and the tile position of the bottom-right tile in a rectangular region of the *i*-th identified temporal motion-constrained tile set, respectively, in tile raster scan order.

mc_exact_sample_value_match_flag[i] equal to 0 indicates that when the coding tree units that are outside of the i-th identified temporal motion-constrained tile set are not decoded and the boundaries of the temporal motion-constrained tile set are treated as picture boundaries for purposes of the decoding process, the value of each sample in the identified tile set may not be exactly the same as the value of the same sample when all the coding tree units of the picture are decoded. **mc_exact_sample_value_match_flag[i]** equal to 1 indicates that when the coding tree units that do not belong to the temporal motion-constrained tile set are not decoded and the boundaries of the temporal motion-constrained tile set are treated as picture boundaries for purposes of the decoding process, the value of each sample in the temporal motion-constrained tile set would be exactly the same as the value of the sample that would be obtained when all the coding tree units of all pictures in associatedPicSet are decoded.

NOTE 3 It is likely to be feasible to use **mc_exact_sample_value_match_flag[i]** equal to 1 when using certain combinations of **loop_filter_across_tiles_enabled_flag**, **pps_loop_filter_across_slices_enabled_flag**, **pps_deblocking_filter_disabled_flag**, **slice_loop_filter_across_slices_enabled_flag**, **slice_deblocking_filter_disabled_flag**, **sample_adaptive_offset_enabled_flag**, **slice_sao_luma_flag**, and **slice_sao_chroma_flag**.

mcts_tier_level_idc_present_flag[i] equal to 1 specifies that the **mcts_tier_flag[i]** and **mcts_level_idc[i]** syntax elements are present. **mcts_tier_level_idc_present_flag[i]** equal to 0 specifies that the **mcts_tier_flag[i]** and **mcts_level_idc[i]** syntax elements are not present. When **mcts_tier_level_idc_present_flag[i]** is equal to 1, **num_tile_rects_in_set_minus1[i]** shall be equal to 0 and a slice segment containing one or more coding tree units within the i-th motion-constrained tile set shall not include any coding tree unit outside the i-th motion-constrained tile set. When not present, **mcts_tier_level_idc_present_flag[i]** is inferred to be equal to 0.

mcts_tier_flag[i] specifies the tier context for the interpretation of **mcts_level_idc[i]** corresponding to the i-th motion-constrained tile set. **mcts_tier_flag[i]** equal to 0 indicates conformance to the Main tier, and **mcts_tier_flag[i]** equal to 1 indicates conformance to the High tier, according to the tier constraints specified in Table A.6. **mcts_tier_flag[i]** shall be equal to 0 when **mcts_level_idc[i]** is less than 120. When not present, the value of **mcts_tier_flag[i]** is inferred to be equal to **general_tier_flag**.

mcts_level_idc[i] indicates a level to which the i-th tile set region, corresponding to the i-th motion-constrained tile set, conforms. The value of **mcts_level_idc[i]** shall be less than or equal to the value of **general_level_idc** in the active SPS RBSP. When not present, the value of **mcts_level_idc[i]** is inferred to be equal to **general_level_idc**.

mcts_max_tier_level_idc_present_flag equal to 1 specifies that the **mcts_max_tier_flag** and **mcts_max_level_idc** syntax elements are present. **mcts_max_tier_level_idc_present_flag** equal to 0 specifies that the **mcts_max_tier_flag** and **mcts_max_level_idc** syntax elements are not present. When **mcts_max_tier_level_idc_present_flag** is equal to 1, a slice segment containing one or more coding tree units within a tile shall not include any coding tree unit outside the tile. When not present, **mcts_max_tier_level_idc_present_flag** is inferred to be equal to 0.

mcts_max_tier_flag specifies the tier context for the interpretation of **mcts_max_level_idc** to which all motion-constrained tile sets conform. **mcts_max_tier_flag** equal to 0 indicates conformance to the Main tier, and **mcts_max_tier_flag** equal to 1 indicates conformance to the High tier, according to the tier constraints specified in Table A.6. **mcts_max_tier_flag** shall be equal to 0 when **mcts_max_level_idc** is less than 120. When not present, the value of **mcts_max_tier_flag** is inferred to be equal to **general_tier_flag**.

mcts_max_level_idc indicates a level to which all motion-constrained tile sets conform. The value of **mcts_max_level_idc** shall be less than or equal to the value of **general_level_idc** in the active SPS RBSP. When not present, the value of **mcts_max_level_idc** is inferred to be equal to **general_level_idc**.

The following describes the tier and level restrictions on the bitstreams of each motion-constrained tile set:

- If **mcts_tier_level_idc_present_flag[i]** and **mcts_max_tier_level_idc_present_flag** are both equal to 0, the **mctsLevelIdc[i]** of all motion-constrained tile sets are inferred to be equal to **general_level_idc**

and the $mctsTierFlag[i]$ of all motion-constrained tile sets are inferred to be equal to $general_tier_flag$ and the specifications of Annex A apply to all motion-constrained tile sets.

- Otherwise ($mcts_tier_level_idc_present_flag[i]$ or $mcts_max_tier_level_idc_present_flag$ is equal to 1), the following apply:
 - The variables $mctsLevelIdc[i]$, $mctsTierFlag[i]$, $mctsWidthInSamplesY[i]$, $mctsHeightInSamplesY[i]$, $NumTileColumnsInMCTS[i]$ and $NumTileRowsInMCTS[i]$ are derived as follows:
 - If $each_tile_one_tile_set_flag$ is equal to 0, for each tile set with index i in the range of 0 to $num_sets_in_message_minus1$, inclusive, the following apply:
 - $mctsLevelIdc[i]$ is set equal to $mcts_level_idc[i]$.
 - $mctsTierFlag[i]$ is set equal to $mcts_tier_flag[i]$.
 - $mctsWidthInSamplesY[i]$ is set equal to the sum of $ColumnWidthInLumaSamples[k]$, for all k in the range of $(top_left_tile_index[i][0] \% (num_tile_rows_minus1 + 1))$ to $(bottom_right_tile_index[i][0] \% (num_tile_rows_minus1 + 1))$, inclusive.
 - $mctsHeightInSamplesY[i]$ is set equal to the sum of $RowHeightInLumaSamples[k]$, for all k in the range of $(top_left_tile_index[i][0] / (num_tile_rows_minus1 + 1))$ to $(bottom_right_tile_index[i][0] / (num_tile_rows_minus1 + 1))$, inclusive.
 - $NumTileColumnsInMCTS[i]$ is set equal to $(bottom_right_tile_index[i][0] \% (num_tile_rows_minus1 + 1)) - (top_left_tile_index[i][0] \% (num_tile_rows_minus1 + 1)) + 1$.
 - $NumTileRowsInMCTS[i]$ is set equal to $(bottom_right_tile_index[i][0] / (num_tile_rows_minus1 + 1)) - (top_left_tile_index[i][0] / (num_tile_rows_minus1 + 1)) + 1$.
 - Otherwise ($each_tile_one_tile_set_flag$ is equal to 1), for each tile with $TileId$ i , with i in the range of 0 to $(num_tile_columns_minus1 + 1) * (num_tile_rows_minus1 + 1) - 1$, inclusive, the following apply:
 - $mctsLevelIdc[i]$ is set equal to $mcts_max_level_idc$.
 - $mctsTierFlag[i]$ is set equal to $mcts_max_tier_flag$.
 - $mctsWidthInSamplesY[i]$ is set equal to $ColumnWidthInLumaSamples[i \% (num_tile_rows_minus1 + 1)]$.
 - $mctsHeightInSamplesY[i]$ is set equal to $RowHeightInLumaSamples[i / (num_tile_rows_minus1 + 1)]$.
 - $NumTileColumnsInMCTS[i]$ is set equal to 1.
 - $NumTileRowsInMCTS[i]$ is set equal to 1.
 - The variables $mctsSizeInSamplesY[i]$ and $NumSliceSegmentsInMCTS[i]$ are derived as follows:
 - $mctsSizeInSamplesY[i]$ is set equal to $mctsWidthInSamplesY[i] * mctsHeightInSamplesY[i]$.

- NumSliceSegmentsInMCTS[*i*] is set equal to the number of slice segments in the *i*-th motion-constrained tile set.
- The variables mctsMaxLumaPs[*i*], mctsMaxCPB[*i*], mctsMaxSliceSegments[*i*], mctsMaxTileRows[*i*], mctsMaxTileCols[*i*], mctsMaxBR[*i*] and mctsMinCr[*i*] are set equal MaxLumaPs, MaxCPB, MaxSliceSegmentsPerPicture, MaxTileRows, MaxTileCols, and MaxBR, respectively, specified in Table A.6 for the level indicated by mctsLevelIdc[*i*] with the tier indicated by mctsTierFlag[*i*].
- The variable mctsMinCr[*i*] is set equal to MinCr specified in Table A.7 for the level indicated by mctsLevelIdc[*i*] with the tier indicated by mctsTierFlag[*i*].
- mctsLevelIdc[*i*] and mctsTierFlag[*i*] indicate the level and tier to which the *i*-th motion-constrained tile set conforms, as specified in Annex A with the following modifications and additions:
 - The variable PicSizeInSamplesY is replaced with the variable mctsSizeInSamplesY[*i*].
 - The value of num_tile_columns_minus1 is replaced with the variable NumTileColumnsInMCTS[*i*] - 1.
 - The value of num_tile_rows_minus1 is replaced with the variable NumTileRowsInMCTS[*i*] - 1.
 - The number of slice segments for the *i*-th motion-constrained tile set is set to NumSliceSegmentsInMCTS[*i*].
 - The variable MaxTileCols, MaxTileRows, MaxSliceSegmentsPerPicture, MaxLumaPs, MaxBR, and MinCr are replaced with the variables mctsMaxTileCols[*i*], mctsMaxTileRows[*i*], mctsMaxSliceSegments[*i*], mctsMaxLumaPs[*i*], mctsMaxBR[*i*], and mctsMinCr[*i*], respectively.
 - The nominal removal time of motion-constrained tile set from the CPB shall be the same as removal time of corresponding access unit.
 - The difference between consecutive output times of motion-constrained tile sets from the DPB shall be same as difference between the output times of corresponding access unit.
 - The value of NumBytesInNalUnit is replaced with the sum of the sizes of all NAL units belonging to the *i*-th motion-constrained tile set in bytes.

D.3.31 Chroma resampling filter hint SEI message semantics

The chroma resampling filter hint SEI message signals one downsampling process and one upsampling process for the chroma components of decoded pictures. When the sampling processes signalled in the chroma resampling filter hint SEI message are used, for any number of upsampling and downsampling iterations performed on the decoded pictures, the degradation of the colour components is expected to be minimized.

The chroma resampling filter hint SEI message shall not be present in a CLVS that has chroma_format_idc equal to 0.

It is a requirement of bitstream conformance that when a chroma resampling filter hint SEI message is present in a CLVS, chroma_sample_loc_type_top_field shall be equal to chroma_sample_loc_type_bottom_field in the same CLVS.

ver_chroma_filter_idc identifies the vertical components of the downsampling and upsampling sets of filters as specified in Table D.13. Based on the value of **ver_chroma_filter_idc**, the values of **verFilterCoeff**[][] are derived from Table D.18. The value of **ver_chroma_filter_idc** shall be in the range of 0 to 2, inclusive. Values of **ver_chroma_filter_idc** greater than 2 are reserved for future use by ITU-T | ISO/IEC.

When **ver_chroma_filter_idc** is equal to 0, the chroma resampling filter in the vertical direction is unspecified.

When **chroma_format_idc** is equal to 1, **ver_chroma_filter_idc** shall be equal to 1 or 2.

Table D.13 — ver_chroma_filter_idc values

Value	Description
0	Unspecified
1	Filters signalled by ver_filter_coeff [][]
2	Filters as described in SMPTE RP 2050-1:2012
>2	Reserved

hor_chroma_filter_idc identifies the horizontal components of the downsampling and upsampling sets of filters as specified in Table D.14. Based on the value of **hor_chroma_filter_idc**, the values of **horFilterCoeff**[][] are derived from Table D.19. The value of **hor_chroma_filter_idc** shall be in the range of 0 to 2, inclusive. Values of **hor_chroma_filter_idc** greater than 2 are reserved for future use by ITU-T | ISO/IEC.

When **hor_chroma_filter_idc** is equal to 0, the chroma resampling filter in the horizontal direction is unspecified.

When **chroma_format_idc** is equal to 3, **hor_chroma_filter_idc** shall be equal to 1 or 2.

When **chroma_format_idc** is equal to 2 and **ver_chroma_filter_idc** is equal to 2, **hor_chroma_filter_idc** shall be equal to 0.

It is a requirement of bitstream conformance that **ver_chroma_filter_idc** and **hor_chroma_filter_idc** shall not be both equal to 0.

Table D.14 — hor_chroma_filter_idc values

Value	Description
0	Unspecified
1	Filters signalled by hor_filter_coeff [][]
2	Filters as described in the 5/3 filter description of Rec. ITU-T T.800 ISO/IEC 15444-1
>2	Reserved

ver_filtering_field_processing_flag indicates whether the vertical operations of the downsampling and the upsampling sets of filters should be applied on a field-basis or a frame-basis. When **field_seq_flag** is equal to 1 and **pic_struct** is not within the range of 9 to 12 inclusive, **ver_filtering_field_processing_flag** shall be equal to 1.

Based on the values of **ver_filtering_field_processing_flag** and **field_seq_flag**, the following apply:

- If **ver_filtering_field_processing_flag** is equal to 1:
 - If **field_seq_flag** is equal to 1, each output field should be filtered independently.

- Otherwise (field_seq_flag is equal to 0), for each decoded frame the filtering process should be applied to chroma samples belonging to the top field and to chroma samples belonging to the bottom field separately.
- Otherwise (ver_filtering_field_processing_flag is equal to 0):
 - If field_seq_flag is equal to 1, the filtering process should be performed on a frame basis. The input of the filtering process should be frames resulting from the interleaving of fields in accordance with the information conveyed by the pic_struct values.
 - Otherwise (field_seq_flag is equal to 0), the filtering process should be performed on a frame basis.

The variable chromaSampleLocType is derived as follows:

- If chroma_format_idc is equal to 1, chromaSampleLocType is set equal to chroma_sample_loc_type_top_field.
- Otherwise (chroma_format_idc is not equal to 1), chromaSampleLocType is set equal to 0.

When chromaSampleLocType is greater than 1, ver_chroma_filter_idc shall not be equal to 2.

When chromaSampleLocType is equal to 1, 3 or 5, hor_chroma_filter_idc shall not be equal to 2.

target_format_idc indicates the output sampling format of the chroma components (i.e. the position of chroma samples relative to that of the luma samples) after filtering, as specified in Table D.15. The value of target_format_idc shall be in the range of 1 to 3, inclusive. The value of target_format_idc shall not be equal to the value of chroma_format_idc.

When not present, the value of target_format_idc is inferred as follows:

- If chroma_format_idc is equal to 1 and ver_chroma_filter_idc is equal to 2, the following apply:
 - If hor_chroma_filter_idc is not equal to 2, the value of target_format_idc is inferred to be equal to 2.
 - Otherwise (hor_chroma_filter_idc is equal to 2), the value of target_format_idc is inferred to be equal to 3.
- Otherwise, if chroma_format_idc is equal to 2, the following apply:
 - If ver_chroma_filter_idc is equal to 2, the value of target_format_idc is inferred to be equal to 1.
 - Otherwise (ver_chroma_filter_idc is not equal to 2), the value of target_format_idc is inferred to be equal to 3.
- Otherwise, if chroma_format_idc is equal to 3, the following apply:
 - If ver_chroma_filter_idc is equal to 2, the value of target_format_idc is inferred to be equal to 1.
 - Otherwise (ver_chroma_filter_idc is not equal to 2), the value of target_format_idc is inferred to be equal to 2.

When chroma_format_idc is greater than 1 and target_format_idc is greater than 1, ver_chroma_filter_idc shall be equal to 0.

When chroma_format_idc is less than 3 and target_format_idc is less than 3, hor_chroma_filter_idc shall be equal to 0.

Table D.15 — Chroma sampling format indicated by target_format_idc

target_format_idc	Chroma sampling format
1	4:2:0
2	4:2:2
3	4:4:4

NOTE The logic associating sampling formats to numeric values of target_format_idc here is the same as the one used to associate sampling formats to numeric values of chroma_format_idc, as described in 6.2.

The variable upsamplingFlag is derived as follows:

- If chroma_format_idc is greater than target_format_idc, upsamplingFlag is set equal to 0.
- Otherwise (chroma_format_idc is less than target_format_idc), upsamplingFlag is set equal to 1.

num_vertical_filters specifies the number of filters signalled for chroma downsampling and upsampling in the vertical direction. When ver_chroma_filter_idc is equal to 1, depending on the values of chromaSampleLocType and ver_filtering_field_processing_flag, the value of num_vertical_filters shall be equal to the values specified in Table D.16.

Table D.16 — Constraints on the value of num_vertical_filters

chromaSampleLocType	Conditions		Mandatory value of num_vertical_filters
	ver_filtering_field_processing_flag		
0, 1	0		2
	1		3
2, 3	0		3
	1		5
4, 5	0		3
	1		5

ver_tap_length_minus1[i] plus 1 specifies the length of the i-th filter in the vertical direction. The value of ver_tap_length_minus1[i] shall be in the range of 0 to 31, inclusive.

ver_filter_coeff[i][j] specifies the value of the j-th coefficient of the i-th filter in the vertical direction. The value of ver_filter_coeff[i][j] shall be in the range of $-2^{31} + 1$ to $2^{31} - 1$, inclusive.

The variable verTapLength[] is derived as follows:

- If ver_chroma_filter_idc is equal to 1, verTapLength[i] is set equal to ver_tap_length_minus1[i] plus 1 for i in the range of 0..num_vertical_filters - 1.
- Otherwise (ver_chroma_filter_idc is equal to 2), the value of verTapLength[] is derived as specified in Table D.18.

The variable verFilterCoeff[i][j] is derived as follows:

- If ver_chroma_filter_idc is equal to 1, verFilterCoeff[i][j] is set equal to ver_filter_coeff[i][j] for i in the range of 0..num_vertical_filters - 1, inclusive, and j in the range of 0..ver_tap_length_minus1[i], inclusive.
- Otherwise (ver_chroma_filter_idc is equal to 2), the values of verFilterCoeff[][] are derived as specified in Table D.18.

num_horizontal_filters specifies the number of filters indicated for chroma downsampling and upsampling in the horizontal direction. When **hor_chroma_filter_idc** is equal to 1, depending on the value of **chromaSampleLocType**, the value of **num_horizontal_filters** shall be equal to the values specified in Table D.17.

Table D.17 — Constraints on the value of num_horizontal_filters

chromaSampleLocType	Mandatory value of num_horizontal_filters
0, 2, 4	3
1, 3, 5	2

hor_tap_length_minus1[*i*] plus 1 specifies the length of the *i*-th filter in the horizontal direction. The value of **hor_tap_length_minus1**[*i*] shall be in the range of 0 to 31, inclusive.

hor_filter_coeff[*i*][*j*] specifies the value of the *j*-th coefficient of the *i*-th filter in the horizontal direction. The value of **hor_filter_coeff**[*i*][*j*] shall be in the range of $-2^{31} + 1$ to $2^{31} - 1$, inclusive.

The variable **horTapLength**[] is derived as follows:

- If **hor_chroma_filter_idc** is equal to 1, **horTapLength**[*i*] is set equal to **hor_tap_length_minus1**[*i*] plus 1 for *i* in the range of 0 to **num_horizontal_filters** - 1, inclusive.
- Otherwise (**hor_chroma_filter_idc** is equal to 2), the values of **horTapLength**[] are derived as specified in Table D.19.

The variable **horFilterCoeff**[][] is derived as follows:

- If **hor_chroma_filter_idc** is equal to 1, **horFilterCoeff**[*i*][*j*] is set equal to **hor_filter_coeff**[*i*][*j*] for *i* in the range of 0 to **num_horizontal_filters** - 1, inclusive, and *j* in the range of 0 to **hor_tap_length_minus1**[*i*], inclusive.
- Otherwise (**hor_chroma_filter_idc** is equal to 2), the values of **horFilterCoeff**[][] are derived as specified in Table D.19.

Table D.18 specifies the coefficients of the sets of chroma downsampling and upsampling filters in the vertical direction when **ver_chroma_filter_idc** is equal to 2.

NOTE 2 When **ver_chroma_filter_idc** is equal to 2, the filter coefficient values specified in Table D.18 correspond to those described in SMPTE RP 2050-1:2012.

Table D.19 specifies the coefficients of the sets of chroma downsampling and upsampling filters in the horizontal direction when **hor_chroma_filter_idc** is equal to 2.

NOTE 3 When **hor_chroma_filter_idc** is equal to 2, the filter coefficient values specified in Table D.19 correspond to those described in the 5/3 filter specification part of Rec. ITU-T T.800 | ISO/IEC 15444-1.

Table D.18 — Values of verFilterCoeff and verTapLength when ver_chroma_filter_idc is equal to 2

Chroma Sample LocType	ver_filtering_field_processing_flag	upsamplingFlag	verFilterCoeff[][]	verTapLength[]
0, 1	0	0	verFilterCoeff[0][] = { -3, -19, 34, 500, 500, 34, -19, -3 }	verTapLength[0] = 8
		1	verFilterCoeff[1][] = { 19, 103, 1037, -135 }	verTapLength[1] = 4
	1	0	verFilterCoeff[0][] = { -8, -26, 115, 586, 409, -48, -4, 0 }	verTapLength[0] = 8
		1	verFilterCoeff[1][] = { 24, -41, 1169, -128 }	verTapLength[1] = 4
			verFilterCoeff[2][] = { -76, 783, 330, -13 }	verTapLength[2] = 4

Table D.19 — Values of horFilterCoeff and horTapLength when hor_chroma_filter_idc is equal to 2

chromaSampleLocType	upsamplingFlag	horFilterCoeff[][]	horTapLength[]
0, 2, 4	0	horFilterCoeff[0][] = { -1, 2, 6, 2, -1 }	horTapLength[0] = 5
	1	horFilterCoeff[1][] = { 1 }	horTapLength[1] = 1
		horFilterCoeff[2][] = { 1, 1 }	horTapLength[2] = 2

The chroma resampling filtering process is applied as follows:

- The variable bottomFlag is derived as follows:
 - If field_seq_flag is equal to 1 and pic_struct is equal to 2, 10 or 12, bottomFlag is set equal to 1.
 - Otherwise, if field_seq_flag is equal to 0 and ver_filtering_field_processing_flag is equal to 1 and the output field being processed is a bottom field, bottomFlag is set equal to 1.
 - Otherwise, bottomFlag is set equal to 0.
- The variables phaseOffsetUp and phaseOffsetDown are derived as follows:
 - If bottomFlag is equal to 1, phaseOffsetUp is set equal to 2 and phaseOffsetDown is set equal to 1.
 - Otherwise (bottomFlag is equal to 0), phaseOffsetUp is set equal to 0 and phaseOffsetDown is set equal to 0.
- The vertical downsampling and upsampling filter coefficients fDv[][] and fUv[][] are specified in Table D.20.
- The horizontal downsampling and upsampling filter coefficients fDh[][] and fUh[][] are specified in Table D.21.
- The vertical downsampling and upsampling filter tap lengths lenDv[] and lenUv[] are specified in Table D.20.

- The horizontal downsampling and upsampling filter tap lengths $lenDh[]$ and $lenUh[]$ are specified in Table D.21.
- When $chroma_format_idc$ is equal to 1 and $target_format_idc$ is equal to either 2 or 3, the chroma upsampling filtering process in the vertical direction is applied once on the Cb samples and once on the Cr samples of the decoded cropped output picture as follows:

- The variables $w0$ and $h0$ are derived as follows:

$$\begin{aligned}
 w0 &= (pic_width_in_luma_samples / SubWidthC) - \\
 & (conf_win_right_offset + conf_win_left_offset) \quad h0 = (pic_height_in_luma_samples \gg 1) - \\
 & (conf_win_top_offset + conf_win_bottom_offset)
 \end{aligned}
 \tag{D-42}$$

- Let $p0X[i][j]$, with i in the range of 0 to $w0 - 1$, inclusive, j in the range of 0 to $h0 - 1$, inclusive, and X being either Cb or Cr, be the input array of Cb or Cr chroma samples from the decoded cropped output picture, and $p1X[i][j]$, with i in the range of 0 to $w0 - 1$, inclusive, j in the range of 0 to $(h0 \ll 1) - 1$, inclusive, and X being either Cb or Cr, be the output array of Cb or Cr chroma samples of the vertical chroma upsampling process.

```

divUv[ 0 ] = 0
divUv[ 1 ] = 0
for( j = 0; j < lenUv[ phaseOffsetUp ]; j++ )
    divUv[ 0 ] += fUv[ phaseOffsetUp ][ j ]
for( j = 0; j < lenUv[ 1 + phaseOffsetUp ]; j++ )
    divUv[ 1 ] += fUv[ 1 + phaseOffsetUp ][ j ]
for( u = 0; u < w0; u++ )
    for( v = 0; v < ( h0 << 1 ); v++ ) {
        sum = 0
        posOffsetUp = v % 2 + phaseOffsetUp
        for( j = - ( lenUv[ posOffsetUp ] - 1 ) / 2; j <= lenUv[ posOffsetUp ] / 2; j++ ) {
            sum += p0X[ u ][ Clip3( 0, h0 - 1, ( v >> 1 ) + j ) ]
                * fUv[ posOffsetUp ][ j ] + ( lenUv[ posOffsetUp ] - 1 ) / 2 ]
            p1X[ u ][ v ] = ( sum + ( divUv[ v % 2 ] >> 1 ) ) / divUv[ v % 2 ]
        }
    }
    
```

(D-43)

- When $ver_filtering_field_process_flag$ is equal to 1 and $field_seq_flag$ is equal to 0, the chroma upsampling filtering process in the vertical direction is applied to each field of the Cb or Cr chroma components of the cropped output frame picture $p0X[i][j]$, with i in the range of 0 to $w0 - 1$, inclusive, j in the range of 0 to $h0 - 1$, inclusive, and X being either Cb or Cr. The following ordered steps apply:

1. The array $p0X$ is deinterleaved into two fields, $p0XTop$ with height being equal to $h0 \gg 1$ and $p0XBottom$ with height being equal to $h0 - (h0 \gg 1)$.
2. The chroma upsampling filtering process in the vertical direction according to Formula (D-43) is applied to $p0XTop$ and $p0XBottom$ to derive the output of the filtering process $p1XTop$ and $p1XBottom$.
3. The arrays $p1XTop$ and $p1XBottom$ are interleaved to form the output array $p1X$ of the upsampling filtering process.

- When $chroma_format_idc$ is equal to either 1 or 2 and $target_format_idc$ is equal to 3, the chroma upsampling filtering process in the horizontal direction is applied once on the Cb samples and once on the Cr samples of the decoded picture as follows:

- The variables $w0$ and $h0$ are derived as follows:

$$\begin{aligned}
 h0 &= (\text{pic_height_in_luma_samples} / \text{SubHeightC}) - \\
 & (\text{conf_win_top_offset} + \text{conf_win_bottom_offset}) \quad w0 = \\
 & (\text{pic_width_in_luma_samples} \gg 1) - (\text{conf_win_right_offset} + \text{conf_win_left_offset}) \quad \text{(D-44)}
 \end{aligned}$$

- Let $p0X[i][j]$, with i in the range of 0 to $w0 - 1$, inclusive, j in the range of 0 to $h0 - 1$, inclusive, and X being either Cb or Cr, be the input array of Cb or Cr chroma samples from the decoded cropped output picture, and $p1X[i][j]$, with i in the range of 0 to $(w0 \ll 1) - 1$, inclusive, j in the range of 0 to $h0 - 1$, inclusive, and X being either Cb or Cr, be the output array of Cb or Cr chroma samples of the horizontal chroma upsampling process.

```

divUh[ 0 ] = 0
divUh[ 1 ] = 0
for( j = 0; j < lenUh[ 0 ]; j++ )
    divUh[ 0 ] += fUh[ 0 ][ j ]
for( j = 0; j < lenUh[ 1 ]; j++ )
    divUh[ 1 ] += fUh[ 1 ][ j ]
for( v = 0; v < h0; v++ )
    for( u = 0; u < ( w0 << 1 ); u++ ) {
        sum = 0
        for( i = -( lenUh[ u % 2 ] - 1 ) / 2; i <= lenUh[ u % 2 ] / 2; i++ )
            sum += p0X[ Clip3( 0, w0 - 1, ( u >>
1 ) + i ) ][ v ] * fUh[ u % 2 ][ i + ( lenUh[ u % 2 ] - 1 ) / 2 ]
        p1X[ u ][ v ] = ( sum + ( divUh[ u % 2 ] >> 1 ) ) / divUh[ u % 2 ]
    }
    
```

(D-45)

- When `chroma_format_idc` is equal to either 3 or 2 and `target_format_idc` is equal to 1, the chroma downsampling filtering process in the vertical direction is applied once on the Cb samples and once on the Cr samples of the decoded picture as follows:

- The variables $w0$ and $h0$ are derived as follows:

$$\begin{aligned}
 w0 &= (\text{pic_width_in_luma_samples} / \text{SubWidthC}) - \\
 & (\text{conf_win_right_offset} + \text{conf_win_left_offset}) \quad h0 = \text{pic_height_in_luma_samples} - \\
 & (\text{conf_win_top_offset} + \text{conf_win_bottom_offset}) \quad \text{(D-46)}
 \end{aligned}$$

- Let $p0X[i][j]$, with i in the range of 0 to $w0 - 1$, inclusive, j in the range of 0 to $h0 - 1$, inclusive, and X being either Cb or Cr, be the input array of Cb or Cr chroma samples from the decoded cropped output picture, and $p1X[i][j]$, with i in the range of 0 to $w0 - 1$, inclusive, j in the range of 0 to $(h0 \gg 1) - 1$, inclusive, and X being either Cb or Cr, be the output array of Cb or Cr chroma samples of the vertical chroma downsampling process.

```

divDv = 0
for( j = 0; j < lenDv[ phaseOffsetDown ]; j++ )
    divDv += fDv[ phaseOffsetDown ][ j ]
for( u = 0; u < w0; u++ )
    for( v = 0; v < ( h0 >> 1 ); v++ ) {
        sum = 0
        for( j = -( lenDv[ phaseOffsetDown ] - 1 ) / 2; j <= lenDv[ phaseOffsetDown ] / 2; j++ )
            sum += p0X[ u ][ Clip3( 0, h0 - 1, ( v << 1 ) + j ) ]
                * fDv[ phaseOffsetDown ][ j + ( lenDv[ phaseOffsetDown ] - 1 ) / 2 ]
        p1X[ u ][ v ] = ( sum + ( divDv >> 1 ) ) / divDv
    }
    
```

(D-47)

- When `ver_filtering_field_process_flag` is equal to 1 and `field_seq_flag` is equal to 0, the chroma downsampling filtering process in the vertical direction is applied to each field of each of the Cb and Cr chroma components of the cropped output frame picture `p0X[i][j]`, with `i` in the range of 0 to `w0 - 1`, inclusive, `j` in the range of 0 to `h0 - 1`, inclusive, and `X` being either Cb or Cr. The following ordered steps apply:
 1. The array `p0X` is deinterleaved into two fields, `p0XTop` with height being equal to `h0 >> 1` and `p0XBottom` with height being equal to `h0 - (h0 >> 1)`.
 2. The chroma downsampling filtering process in the vertical direction according to Formula (D-47) is applied to `p0XTop` and `p0XBottom` to derive the output of the filtering process `p1XTop` and `p1XBottom`.
 3. The arrays `p1XTop` and `p1XBottom` are interleaved to form the output array `p1X` of the downsampling filtering process.
- When `chroma_format_idc` is equal to 3 and `target_format_idc` is equal to either 1 or 2, the chroma downsampling filtering process in the horizontal direction is applied once on the Cb samples and once on the Cr samples of the decoded picture as follows:

- The variables `w0` and `h0` are derived as follows:

$$\begin{aligned}
 h0 &= (\text{pic_height_in_luma_samples} / \text{SubHeightC}) - (\text{conf_win_top_offset} + \\
 &\quad \text{conf_win_bottom_offset}) \\
 w0 &= \text{pic_width_in_luma_samples} - (\text{conf_win_right_offset} + \text{conf_win_left_offset}) \quad (\text{D-48})
 \end{aligned}$$

- Let `p0X[i][j]`, with `i` in the range of 0 to `w0 - 1`, inclusive, `j` in the range of 0 to `h0 - 1`, inclusive, and `X` being either Cb or Cr, be the input array of Cb or Cr chroma samples from the decoded cropped output picture, and `p1X[i][j]`, with `i` in the range of 0 to `(w0 >> 1) - 1`, inclusive, `j` in the range of 0 to `h0 - 1`, inclusive, and `X` being either Cb or Cr, be the output array of Cb or Cr chroma samples of the horizontal chroma downsampling process.

```

divUh = 0
for( j = 0; j < lenDh; j++ )
    divDh += fDh[ 0 ][ j ]
for( v = 0; v < h0; v++ )
    for( u = 0; u < ( w0 >> 1 ); u++ ) {
        sum = 0
        for( i = -(lenDh - 1) / 2; i <= lenDh / 2; i++ )
            sum += p0X[ Clip3( 0, w0 - 1, ( u << 1 ) + i ) ][ v ] * fDh[ 0 ][ i + ( lenDh - 1 ) / 2 ]
        p1X[ u ][ v ] = ( sum + ( divDh >> 1 ) ) / divDh
    }
  
```

(D-49)

Table D.20 — Usage of chroma filter in the vertical direction

chromaSampleLocType	ver_filtering_flag_processing_flag	num_vertical_filters (when applicable)	upsamplingFlag	bottomFlag	Filter coefficients (fDv for downsampling or fUv for upsampling)	Filter tap length (lenDv for downsampling or lenUv for upsampling)
0, 1	0	2	0	-	$fDv[0][j] = verFilterCoeff[0][j]$ $j = 0..lenDv[0] - 1$	$lenDv[0] = verTapLength[0]$
			1	-	$fUv[0][j] = verFilterCoeff[1][j]$ $j = 0..lenUv[0] - 1$	$lenUv[0] = verTapLength[1]$
	-	$fUv[1][j] = verFilterCoeff[1][verTapLength[1] - j - 1]$ $j = 0..lenUv[1] - 1$		$lenUv[1] = verTapLength[1]$		
	1	3	0	0	$fDv[0][j] = verFilterCoeff[0][j]$ $j = 0..lenDv[0] - 1$	$lenDv[0] = verTapLength[0]$
				1	$fDv[1][j] = verFilterCoeff[0][verTapLength[0] - j - 1]$ $j = 0..lenDv[1] - 1$	$lenDv[1] = verTapLength[0]$
			0	0	$fUv[0][j] = verFilterCoeff[1][j]$ $j = 0..lenUv[0] - 1$	$lenUv[0] = verTapLength[1]$
				1	$fUv[1][j] = verFilterCoeff[2][j]$ $j = 0..lenUv[1] - 1$	$lenUv[1] = verTapLength[2]$
			1	1	$fUv[2][j] = verFilterCoeff[1][verTapLength[1] - j - 1]$ $j = 0..lenUv[2] - 1$	$lenUv[2] = verTapLength[1]$
				1	$fUv[3][j] = verFilterCoeff[2][verTapLength[2] - j - 1]$ $j = 0..lenUv[3] - 1$	$lenUv[3] = verTapLength[2]$
	2, 3	0	3	0	-	$fDv[0][j] = verFilterCoeff[0][j]$ $j = 0..lenDv[0] - 1$
			1	-	$fUv[0][j] = verFilterCoeff[1][j]$ $j = 0..lenUv[0] - 1$	$lenUv[0] = verTapLength[1]$
				-	$fUv[1][j] = verFilterCoeff[2][j]$ $j = 0..lenUv[1] - 1$	$lenUv[1] = verTapLength[2]$
	1	5	0	0	$fDv[0][j] = verFilterCoeff[0][j]$ $j = 0..lenDv[0] - 1$	$lenDv[0] = verTapLength[0]$
				1	$fDv[1][j] = verFilterCoeff[1][j]$ $j = 0..lenDv[1] - 1$	$lenDv[1] = verTapLength[1]$
			1	0	$fUv[0][j] = verFilterCoeff[2][j]$ $j = 0..lenUv[0] - 1$	$lenUv[0] = verTapLength[2]$
					$fUv[1][j] = verFilterCoeff[3][j]$	$lenUv[1] =$

					$j = 0..lenUv[1] - 1$	$verTapLength[3]$		
				1	$fUv[2][j] = verFilterCoeff[4][j]$ $j = 0..lenUv[2] - 1$	$lenUv[2] = verTapLength[4]$		
					$fUv[3][j] = verFilterCoeff[4][verTapLength[4] - j - 1]$ $j = 0..lenUv[3] - 1$	$lenUv[3] = verTapLength[4]$		
4, 5	0	3	0	-	$fDv[0][j] = verFilterCoeff[0][j]$ $j = 0..lenDv[0] - 1$	$lenDv[0] = verTapLength[0]$		
			1	-	$fUv[0][j] = verFilterCoeff[1][j]$ $j = 0..lenUv[0] - 1$	$lenUv[0] = verTapLength[1]$		
					$fUv[1][j] = verFilterCoeff[2][j]$ $j = 0..lenUv[1] - 1$	$lenUv[1] = verTapLength[2]$		
	1	5	0	0		$fDv[0][j] = verFilterCoeff[0][j]$ $= 0..lenDv[0] - 1$	$lenDv[0] = verTapLength[0]$	
				1		$fDv[1][j] = verFilterCoeff[1][j]$ $j = 0..lenDv[1] - 1$	$lenDv[1] = verTapLength[1]$	
			1	0			$fUv[0][j] = verFilterCoeff[2][j]$ $j = 0..lenUv[0] - 1$	$lenUv[0] = verTapLength[2]$
							$fUv[1][j] = verFilterCoeff[2][verTapLength[2] - j - 1]$ $j = 0..lenUv[1] - 1$	$lenUv[1] = verTapLength[2]$
				1			$fUv[2][j] = verFilterCoeff[3][j]$ $j = 0..lenUv[2] - 1$	$lenUv[2] = verTapLength[3]$
							$fUv[3][j] = verFilterCoeff[4][j]$ $j = 0..lenUv[3] - 1$	$lenUv[3] = verTapLength[4]$

STANDARDSISO.COM : Click to view the full PDF of ISO/IEC 23008-2:2017

Table D.21 — Usage of chroma filter in the horizontal direction

chromaSampleLocType	num_horizontal_filters (when applicable)	upsamplingFlag	Filter coefficients (fDh for downsampling or fUh for upsampling)	Filter tap length (lenDh for downsampling or lenUh for upsampling)
0, 2, 4	3	0	$fDh[0][j] = horFilterCoeff[0][j] \quad j = 0..lenDh - 1$	$lenDh = horTapLength[0]$
		1	$fUh[0][j] = horFilterCoeff[1][j] \quad j = 0..lenUh[0] - 1$	$lenUh[0] = horTapLength[1]$
			$fUh[1][j] = horFilterCoeff[2][j] \quad j = 0..lenUh[1] - 1$	$lenUh[1] = horTapLength[2]$
1, 3, 5	2	0	$fDh[0][j] = horFilterCoeff[0][j] \quad j = 0..lenDh - 1$	$lenDh = horTapLength[0]$
		1	$fUh[0][j] = horFilterCoeff[1][j] \quad j = 0..lenUh[0] - 1$	$lenUh[0] = horTapLength[1]$
			$fUh[1][j] = horFilterCoeff[1][horTapLength[1] - j - 1] \quad j = 0..lenUh[1] - 1$	$lenUh[1] = horTapLength[1]$

D.3.32 Knee function information SEI message semantics

The knee function information SEI message provides information to enable mapping of the colour samples of decoded pictures for customisation to particular display environments. The process uses a knee function to map the white level of sample values in the normalized linear RGB colour space to an appropriate luminance level and should be applied to each RGB component produced by the colour space conversion of a decoded image.

A knee function is a piece-wise linear function that starts with the point (0.0, 0.0), ends with the point (1.0, 1.0) and is specified by knee points in ascending order of index i. The coordinate of the i-th knee point is specified by (input_knee_point[i] ÷ 1000, output_knee_point[i] ÷ 1000). A knee function maps the input luminance level normalized in the range of 0.0 to 1.0 to the output luminance level normalized in the range of 0.0 to 1.0. An example of a knee function is shown in Figure D.11.

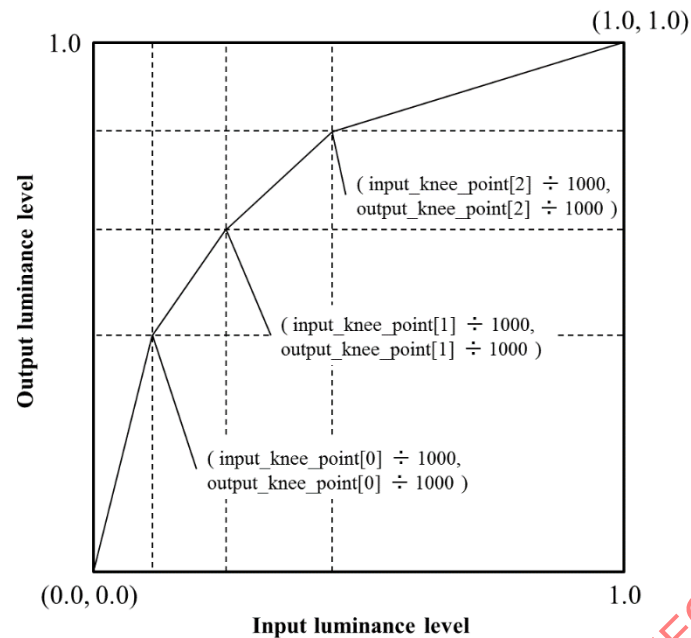

Figure D.11 — A knee function with `num_knee_points` minus 1 equal to 2

knee_function_id contains an identifying number that may be used to identify the purpose of the knee functions. The value of `knee_function_id` shall be in the range of 0 to $2^{32} - 2$, inclusive.

Values of `knee_function_id` from 0 to 255, inclusive, and from 512 to $2^{31} - 1$, inclusive, may be used as determined by the application. Values of `knee_function_id` from 256 to 511, inclusive, and from 2^{31} to $2^{32} - 2$, inclusive, are reserved for future use by ITU-T | ISO/IEC. Decoders shall ignore all knee function information SEI messages containing a value of `knee_function_id` in the range of 256 to 511, inclusive, or in the range of 2^{31} to $2^{32} - 2$, inclusive, and bitstreams shall not contain such values.

NOTE 1 The `knee_function_id` can be used to support knee function processes that are suitable for different display scenarios. For example, different values of `knee_function_id` may correspond to different display bit depths.

knee_function_cancel_flag equal to 1 indicates that the knee function information SEI message cancels the persistence of any previous knee function information SEI messages in output order that applies to the current layer. `knee_function_cancel_flag` equal to 0 indicates that knee function information follows.

knee_function_persistence_flag specifies the persistence of the knee function information SEI message for the current layer.

`knee_function_persistence_flag` equal to 0 specifies that the knee function information applies to the current decoded picture only.

Let `picA` be the current picture. `knee_function_persistence_flag` equal to 1 specifies that the knee function information persists for the current layer in output order until any of the following conditions are true:

- A new CLVS of the current layer begins.
- The bitstream ends.
- A picture `picB` in the current layer in an access unit containing a knee function information SEI message with the same value of `knee_function_id` and applicable to the current layer is output for which `PicOrderCnt(picB)` is greater than `PicOrderCnt(picA)`, where `PicOrderCnt(picB)` and `PicOrderCnt(picA)` are the `PicOrderCntVal` values of `picB` and `picA`, respectively, immediately after the invocation of the decoding process for picture order count for `picB`.

input_d_range specifies the peak luminance level for the input picture of the knee function process relative to the nominal luminance level in units of 0.1 %. When the value of input_d_range is equal to 0, the peak luminance level of the input picture is unspecified.

input_disp_luminance specifies the expected display brightness of peak luminance level for the input picture of the knee function process. The value of input_disp_luminance is in units of candelas per square metre. When the value of input_disp_luminance is equal to 0, the expected display brightness of peak luminance level for the input picture is unspecified.

output_d_range specifies the peak luminance level for the output picture of the knee function process relative to the nominal luminance level in units of 0.1 %. When the value of output_d_range is equal to 0, the peak luminance level of the output picture is unspecified.

output_disp_luminance specifies the expected display brightness of peak luminance level for the output picture of the knee function process. The value of output_disp_luminance is in units of candelas per square metre. When the value of output_disp_luminance is equal to 0, the expected display brightness of peak luminance level for the output picture is unspecified.

num_knee_points_minus1 plus 1 specifies the number of knee points used to define the knee function. num_knee_points_minus1 shall be in the range of 0 to 998, inclusive.

input_knee_point[i] specifies the luminance level of the i-th knee point of the input picture. The luminance level of the knee point of the input picture is normalized to the range of 0 to 1.0 in units of 0.1 %. The value of input_knee_point[i] shall be in the range of 1 to 999, inclusive. The value of input_knee_point[i] shall be greater than the value of input_knee_point[i - 1], for i in the range of 1 to num_knee_points_minus1, inclusive.

output_knee_point[i] specifies the luminance level of the i-th knee of the output picture. The luminance level of the knee point of the output picture is normalized to the range of 0 to 1.0 in units of 0.1 %. The value of output_knee_point[i] shall be in the range of 0 to 1000, inclusive. The value of output_knee_point[i] shall be greater than or equal to the value of output_knee_point[i - 1], for i in the range of 1 to num_knee_points_minus1, inclusive.

NOTE 2 The luminance level conversion process between an input signal x and an output signal y, where the luminance levels for both input and output are normalized to be in the range of 0.0 to 1.0, is specified as follows:

```

if( x <= input_knee_point[ 0 ] ÷ 1 000 )
    y = ( output_knee_point[ 0 ] ÷ input_knee_point[ 0 ] ) * x
else if( x > input_knee_point[ num_knee_points_minus1 ] )
    y = ( ( 1 000 - output_knee_point[ num_knee_points_minus1 ] ) ÷
        ( 1 000 - input_knee_point[ num_knee_points_minus1 ] ) ) *
        ( x - input_knee_point[ num_knee_points_minus1 ] ÷ 1 000 ) +
        ( output_knee_point[ num_knee_points_minus1 ] ÷ 1 000 )
else
    for( i = 1; i <= num_knee_points_minus1; i++ )
        if( input_knee_point[ i - 1 ] ÷ 1 000 < x && x <= input_knee_point[ i ] ÷ 1 000 )
            y = ( ( output_knee_point[ i ] - output_knee_point[ i - 1 ] ) ÷
                ( input_knee_point[ i ] - input_knee_point[ i - 1 ] ) ) *
                ( x - input_knee_point[ i - 1 ] ÷ 1 000 ) + ( output_knee_point[ i - 1 ] ÷ 1 000 )

```

D.3.33 Colour remapping information SEI message semantics

The colour remapping information SEI message provides information to enable remapping of the reconstructed colour samples of the output pictures for purposes such as converting the output pictures to a representation that is more suitable for an alternative display. The colour remapping model used in the colour remapping information SEI message is composed of a first piece-wise linear function applied to each colour component (specified by the “pre” set of syntax elements herein), followed by a three-by-three matrix applied to the three resulting colour components, followed by a second piece-wise linear function applied to each resulting colour component (specified by the “post” set of syntax elements herein).

NOTE 1 Colour remapping of the output pictures for the display process (which is outside the scope of this document) is optional and does not affect the decoding process specified in this document.

Unless indicated otherwise by some means not specified in this document, the input to the indicated remapping process is the set of decoded sample values after applying an (unspecified) upsampling conversion process to the 4:4:4 colour sampling format as necessary when the colour remapping three-by-three matrix coefficients are present in the SEI message and `chroma_format_idc` is equal to 1 (4:2:0 chroma format) or 2 (4:2:2 chroma format). When `chroma_format_idc` is equal to 0 (monochrome), the colour remapping information SEI message shall not be present, although decoders shall allow such messages to be present and shall ignore any such colour remapping information SEI messages that may be present.

colour_remap_id contains an identifying number that may be used to identify the purpose of the colour remapping information. The value of `colour_remap_id` may be used (in a manner not specified in this document) to indicate that the input to the remapping process is the output of some conversion process that is not specified in this document, such as a conversion of the picture to some alternative colour representation (e.g. conversion from a YCbCr colour representation to a GBR colour representation). When more than one colour remapping information SEI message is present with the same value of `colour_remap_id`, the content of these colour remapping information SEI messages shall be the same. When colour remapping information SEI messages are present that have more than one value of `colour_remap_id`, this may indicate that the remapping processes indicated by the different values of `colour_remap_id` are alternatives that are provided for different purposes or that a cascading of remapping processes is to be applied in a sequential order (an order that is not specified in this document). The value of `colour_remap_id` shall be in the range of 0 to $2^{32} - 2$, inclusive.

Values of `colour_remap_id` from 0 to 255 and from 512 to $2^{31} - 1$ may be used as determined by the application. Values of `colour_remap_id` from 256 to 511, inclusive, and from 2^{31} to $2^{32} - 2$, inclusive, are reserved for future use by ITU-T | ISO/IEC. Decoders shall ignore all colour remapping information SEI messages containing a value of `colour_remap_id` in the range of 256 to 511, inclusive, or in the range of 2^{31} to $2^{32} - 2$, inclusive, and bitstreams shall not contain such values.

NOTE 2 The `colour_remap_id` can be used to support different colour remapping processes that are suitable for different display scenarios. For example, different values of `colour_remap_id` may correspond to different remapped colour spaces supported by displays.

colour_remap_cancel_flag equal to 1 indicates that the colour remapping information SEI message cancels the persistence of any previous colour remapping information SEI message in output order that applies to the current layer. `colour_remap_cancel_flag` equal to 0 indicates that colour remapping information follows.

colour_remap_persistence_flag specifies the persistence of the colour remapping information SEI message for the current layer.

`colour_remap_persistence_flag` equal to 0 specifies that the colour remapping information applies to the current picture only.

Let `picA` be the current picture. `colour_remap_persistence_flag` equal to 1 specifies that the colour remapping information persists for the current layer in output order until either of the following conditions is true:

- A new CLVS of the current layer begins.
- The bitstream ends.
- A picture `picB` in the current layer in an access unit containing a colour remapping information SEI message with the same value of `colour_remap_id` and applicable to the current layer is output for which `PicOrderCnt(picB)` is greater than `PicOrderCnt(picA)`, where `PicOrderCnt(picB)` and `PicOrderCnt(picA)` are the `PicOrderCntVal` values of `picB` and `picA`, respectively, immediately after the invocation of the decoding process for picture order count for `picB`.

colour_remap_video_signal_info_present_flag equal to 1 specifies that syntax elements `colour_remap_full_range_flag`, `colour_remap primaries`, `colour_remap_transfer_function` and `colour_remap_matrix_coefficients` are present, `colour_remap_video_signal_info_present_flag` equal to 0 specifies that syntax elements `colour_remap_full_range_flag`, `colour_remap primaries`, `colour_remap_transfer_function` and `colour_remap_matrix_coefficients` are not present.

colour_remap_full_range_flag has the same semantics as specified in E.3.1 for the `video_full_range_flag` syntax element, except that `colour_remap_full_range_flag` identifies the colour space of the remapped reconstructed picture, rather than the colour space used for the CLVS. When not present, the value of `colour_remap_full_range_flag` is inferred to be equal to the value of `video_full_range_flag`.

colour_remap_primaries has the same semantics as specified in E.3.1 for the `colour primaries` syntax element, except that `colour_remap primaries` identifies the colour space of the remapped reconstructed picture, rather than the colour space used for the CLVS. When not present, the value of `colour_remap primaries` is inferred to be equal to the value of `colour primaries`.

colour_remap_transfer_function has the same semantics as specified in E.3.1 for the `transfer_characteristics` syntax element, except that `colour_remap_transfer_function` identifies the colour space of the remapped reconstructed picture, rather than the colour space used for the CLVS. When not present, the value of `colour_remap_transfer_function` is inferred to be equal to the value of `transfer_characteristics`.

colour_remap_matrix_coefficients has the same semantics as specified in E.3.1 for the `matrix_coeffs` syntax element, except that `colour_remap_matrix_coefficients` identifies the colour space of the remapped reconstructed picture, rather than the colour space used for the CLVS. When not present, the value of `colour_remap_matrix_coefficients` is inferred to be equal to the value of `matrix_coeffs`.

colour_remap_input_bit_depth specifies the bit depth of the colour components of the associated pictures for purposes of interpretation of the colour remapping information SEI message. When any colour remapping information SEI message is present with the value of `colour_remap_input_bit_depth` not equal to the bit depth of the decoded colour components, the SEI message refers to the hypothetical result of a conversion operation performed to convert the decoded colour component samples to the bit depth equal to `colour_remap_input_bit_depth`.

The value of `colour_remap_input_bit_depth` shall be in the range of 8 to 16, inclusive. Values of `colour_remap_input_bit_depth` from 0 to 7, inclusive, and from 17 to 255, inclusive, are reserved for future use by ITU-T | ISO/IEC. Decoders shall ignore all colour remapping SEI messages that contain a `colour_remap_input_bit_depth` in the range of 0 to 7, inclusive, or in the range of 17 to 255, inclusive, and bitstreams shall not contain such values.

colour_remap_output_bit_depth specifies the bit depth of the output of the colour remapping function described by the colour remapping information SEI message.

The value of `colour_remap_output_bit_depth` shall be in the range of 8 to 16, inclusive. Values of `colour_remap_output_bit_depth` from 0 to 7, inclusive, and in the range of 17 to 255, inclusive, are reserved for future use by ITU-T | ISO/IEC. Decoders shall ignore all colour remapping SEI messages that contain a value of `colour_remap_output_bit_depth` from 0 to 7, inclusive, or in the range of 17 to 255, inclusive, and bitstreams shall not contain such values.

pre_lut_num_val_minus1[c] plus 1 specifies the number of pivot points in the piece-wise linear remapping function for the *c*-th component, where *c* equal to 0 refers to the luma or G component, *c* equal to 1 refers to the Cb or B component, and *c* equal to 2 refers to the Cr or R component. When `pre_lut_num_val_minus1[c]` is equal to 0, the default end points of the input values are 0 and $2^{\text{colour_remap_input_bit_depth}} - 1$, and the corresponding default end points of the output values are 0 and $2^{\text{colour_remap_output_bit_depth}} - 1$, for the *c*-th component. In bitstreams conforming to this version of this document, the value of `pre_lut_num_val_minus1[c]` shall be in the range of 0 to 32, inclusive.

pre_lut_coded_value[c][i] specifies the input value of the i-th pivot point for the c-th component. The number of bits used to represent **pre_lut_coded_value**[c][i] is $((\text{colour_remap_input_bit_depth} + 7) \gg 3) \ll 3$.

pre_lut_target_value[c][i] specifies the output value of the i-th pivot point for the c-th component. The number of bits used to represent **pre_lut_target_value**[c][i] is $((\text{colour_remap_output_bit_depth} + 7) \gg 3) \ll 3$.

When **pre_lut_coded_value**[c][0] is greater than 0, an initial linear segment should be inferred that maps input values ranging from 0 to **pre_lut_coded_value**[c][0], inclusive, to target values ranging from 0 to **pre_lut_target_value**[c][0], inclusive.

When **pre_lut_coded_value**[c][**pre_lut_num_val_minus1**[c]] is not equal to $2^{\text{colour_remap_input_bit_depth} - 1}$, a final linear segment should be inferred that maps input values ranging from **pre_lut_coded_value**[c][**pre_lut_num_val_minus1**[c]] to $2^{\text{colour_remap_input_bit_depth} - 1}$, inclusive, to target values ranging from **pre_lut_target_value**[c][**pre_lut_num_val_minus1**[c]] to $2^{\text{colour_remap_output_bit_depth} - 1}$, inclusive.

colour_remap_matrix_present_flag equal to 1 indicates that the syntax elements **log2_matrix_denom** and **colour_remap_coeffs**[c][i], for c and i in the range of 0 to 2, inclusive, are present. **colour_remap_matrix_present_flag** equal to 0 indicates that the syntax elements **log2_matrix_denom** and **colour_remap_coeffs**[c][i], for c and i in the range of 0 to 2, inclusive, are not present.

log2_matrix_denom specifies the base 2 logarithm of the denominator for all matrix coefficients. The value of **log2_matrix_denom** shall be in the range of 0 to 15, inclusive. When not present, the value of **log2_matrix_denom** is inferred to be equal to 0.

colour_remap_coeffs[c][i] specifies the value of the three-by-three colour remapping matrix coefficients. The value of **colour_remap_coeffs**[c][i] shall be in the range of -2^{15} to $2^{15} - 1$, inclusive. When **colour_remap_coeffs**[c][i] is not present, it is inferred to be equal to 1 if c is equal to i, and inferred to be equal to 0 otherwise.

NOTE 3 When **colour_remap_matrix_present_flag** is equal to 0, the colour remapping matrix is inferred to be equal to the identity matrix of size 3x3.

The variable **matrixOutput**[c] for c = 0, 1 and 2 is derived as follows:

$$\begin{aligned} \text{roundingOffset} &= \text{log2_matrix_denom} = 0 ? 0 : 1 \ll (\text{log2_matrix_denom} - 1) \\ \text{matrixOutput}[c] &= \text{Clip3}(0, (1 \ll \text{colour_remap_output_bit_depth}) - 1, \\ &\quad (\text{colour_remap_coeffs}[c][0] * \text{matrixInput}[0] + \text{colour_remap_coeffs}[c][1] * \\ &\quad \text{matrixInput}[1] + \text{colour_remap_coeffs}[c][2] * \text{matrixInput}[2] + \text{roundingOffset}) \gg \\ &\quad \text{log2_matrix_denom}) \end{aligned} \quad (\text{D-50})$$

where **matrixInput**[c] is the input sample value of the c-th colour component, and **matrixOutput**[c] is the output sample value of the c-th colour component.

post_lut_num_val_minus1[c] has the same semantics as **pre_lut_num_val_minus1**[c], with "pre" replaced by "post", except that the default end points of the input values are 0 and $2^{\text{colour_remap_output_bit_depth} - 1}$ for the c-th colour component. The value of **post_lut_num_val_minus1**[c] shall be in the range of 0 to 32, inclusive.

post_lut_coded_value[c][i] has the same semantics as **pre_lut_coded_value**[c][i], with "pre" replaced by "post", except that the number of bits used to represent **post_lut_coded_value**[c][i] is $((\text{colour_remap_output_bit_depth} + 7) \gg 3) \ll 3$.

post_lut_target_value[c][i] has the same semantics as **pre_lut_target_value**[c][i], with "pre" replaced by "post" except that **colour_remap_input_bit_depth** is replaced by **colour_remap_output_bit_depth** in the semantics.

D.3.34 Deinterlaced field identification SEI message semantics

The deinterlaced picture information SEI message indicates that the current picture represents a frame that was interpolated via a deinterlacing process prior to encoding, and indicates the field parity of the associated source field prior to the deinterlacing process. When a progressive-to-interlace conversion process is applied to the decoded picture prior to display, it is recommended that the field of the decoded frame with the indicated field parity should be used.

When the value of `field_seq_flag` of any active SPS for any picture in the current access unit is equal to 1, the deinterlaced field identification SEI message shall not be present.

`deinterlaced_picture_source_parity_flag` equal to 0 indicates that the current picture was deinterlaced using a top field picture as the associated source field. `deinterlaced_picture_source_parity_flag` equal to 1 indicates that the current picture was deinterlaced using a bottom field picture as the associated source field.

D.3.35 Content light level information SEI message semantics

This SEI message identifies upper bounds for the nominal target brightness light level of the pictures of the CLVS.

The information conveyed in this SEI message is intended to be adequate for purposes corresponding to the use of the Consumer Electronics Association 861.3 specification.

The semantics of the content light level information SEI message are defined in relation to the values of samples in a 4:4:4 representation of red, green, and blue colour primary intensities in the linear light domain for the pictures of the CLVS, in units of candelas per square metre. However, this SEI message does not, by itself, identify a conversion process for converting the sample values of a decoded picture to the samples in a 4:4:4 representation of red, green, and blue colour primary intensities in the linear light domain for the picture.

NOTE 1 Other syntax elements, such as `colour_primaries`, `transfer_characteristics`, `matrix_coeffs`, and the chroma resampling filter hint SEI message, when present, may assist in the identification of such a conversion process.

Given the red, green, and blue colour primary intensities in the linear light domain for the location of a luma sample in a corresponding 4:4:4 representation, denoted as E_R , E_G , and E_B , the maximum component intensity is defined as $E_{Max} = \text{Max}(E_R, \text{Max}(E_G, E_B))$. The light level corresponding to the stimulus is then defined as the CIE 1931 luminance corresponding to equal amplitudes of E_{Max} for all three colour primary intensities for red, green, and blue (with appropriate scaling to reflect the nominal luminance level associated with peak white, e.g. ordinarily scaling to associate peak white with 10 000 candelas per square metre when `transfer_characteristics` is equal to 16).

NOTE 2 Since the maximum value E_{Max} is used in this definition at each sample location, rather than a direct conversion from E_R , E_G , and E_B to the corresponding CIE 1931 luminance, the CIE 1931 luminance at a location may in some cases be less than the indicated light level. This situation would occur, for example, when E_R and E_G are very small and E_B is large, in which case the indicated light level would be much larger than the true CIE 1931 luminance associated with the (E_R , E_G , E_B) triplet.

`max_content_light_level`, when not equal to 0, indicates an upper bound on the maximum light level among all individual samples in a 4:4:4 representation of red, green, and blue colour primary intensities (in the linear light domain) for the pictures of the CLVS, in units of candelas per square metre. When equal to 0, no such upper bound is indicated by `max_content_light_level`.

`max_pic_average_light_level`, when not equal to 0, indicates an upper bound on the maximum average light level among the samples in a 4:4:4 representation of red, green, and blue colour primary intensities (in the linear light domain) for any individual picture of the CLVS, in units of candelas per square metre. When equal to 0, no such upper bound is indicated by `max_pic_average_light_level`.

NOTE 3 When the visually relevant region does not correspond to the entire cropped decoded picture, such as for “letterbox” encoding of video content with a wide picture aspect ratio within a taller cropped decoded picture, the indicated average is expected to be performed only within the visually relevant region.

D.3.36 Dependent random access point indication SEI message semantics

The picture associated with a dependent random access point indication SEI message is referred to as a DRAP picture.

The presence of the dependent random access point indication SEI message indicates that the constraints on picture order and picture referencing specified in this subclause apply. These constraints can enable a decoder to properly decode the DRAP picture and the pictures that follow it in both decoding order and output order without needing to decode any other pictures except the associated IRAP picture.

The constraints indicated by the presence of the dependent random access point indication SEI message are as follows.

- The DRAP picture shall be a TRAIL_R picture with TemporalId equal to 0 and nuh_layer_id equal to 0.
- The DRAP picture shall not include any pictures in its RPS lists RefPicSetStCurrBefore, RefPicSetStCurrAfter, and RefPicSetLtCurr except its associated IRAP picture.
- Any picture that follows the DRAP picture in both decoding order and output order shall not include, in its RPS, any picture that precedes the DRAP picture in decoding order or output order with the exception of the IRAP picture associated with the DRAP picture.

D.3.37 Coded region completion SEI message semantics

The coded region completion SEI message indicates the value of the slice_segment_address of the next slice segment in the bitstream (when present) and whether the next slice segment in the bitstream (when present) is an independent slice segment or a dependent slice segment. The term “next slice segment”, here and below in this subclause, refers to the next slice segment, in decoding order, after the VCL NAL unit associated with the SEI NAL unit containing the coded region completion SEI message.

NOTE The coded region completion SEI message may be used in determining that a complete slice, coded picture, or access unit has been received prior to receiving any VCL NAL unit of the next slice, coded picture, or access unit, respectively. Consequently, when an implementation of the decoding process expects a complete slice, coded picture, or access unit as input, the coded region completion SEI message may reduce the decoding latency.

next_segment_address identifies the value of the slice_segment_address of the next slice segment in the bitstream (when present). When the next slice segment has first_slice_segment_in_pic_flag equal to 1 or no subsequent slice segment is present in the bitstream, the value of next_segment_address shall be equal to 0.

independent_slice_segment_flag equal to 1 indicates that the next slice segment, when present, is an independent slice segment. independent_slice_segment_flag equal to 0 indicates that the next slice segment, when present, is a dependent slice segment. When independent_slice_segment_flag is not present, it is inferred to be equal to 1.

D.3.38 Alternative transfer characteristics SEI message semantics

The alternative transfer characteristics SEI message provides a preferred alternative value for the transfer_characteristics syntax element that is indicated by the colour description syntax of VUI parameters of the SPS. This SEI message is intended to be used in cases when some value of transfer_characteristics is preferred for interpretation of the pictures of the CLVS although some other value of transfer_characteristics may also be acceptable for interpretation of the pictures of the CLVS and that other value is provided in the colour description syntax of VUI parameters of the SPS for

interpretation by decoders that do not support interpretation of the preferred value (e.g. because the preferred value had not yet been defined in a previous version of this document).

When an alternative transfer characteristics SEI message is present for any picture of a CLVS of a particular layer and the first picture of the CLVS is an IRAP picture, an alternative transfer characteristics SEI message shall be present for that IRAP picture. The alternative transfer characteristics SEI message persists for the current layer in decoding order from the current picture until the end of the CLVS. All alternative transfer characteristics SEI messages that apply to the same CLVS shall have the same content.

preferred_transfer_characteristics specifies a preferred alternative value for the transfer_characteristics syntax element of the colour description syntax of VUI parameters of the SPS. The semantics for preferred_transfer_characteristics are otherwise the same as for the transfer_characteristics syntax element specified in the VUI parameters of the SPS (see E.3.1 and Table E.4). When preferred_transfer_characteristics is not equal to the value of transfer_characteristics indicated in the VUI parameters of the SPS, decoders should ignore the value of transfer_characteristics indicated in the VUI parameters of the SPS and instead use the value indicated by preferred_transfer_characteristics.

D.3.39 Ambient viewing environment SEI message semantics

The ambient viewing environment SEI message identifies the characteristics of the nominal ambient viewing environment for the display of the associated video content. The syntax elements of the ambient viewing environment SEI message may assist the receiving system in adapting the received video content for local display in viewing environments that may be similar or may substantially differ from those assumed or intended when mastering the video content.

This SEI message does not provide information on colour transformations that would be appropriate to preserve creative intent on displays with colour volumes different from that of the described mastering display.

When an ambient viewing environment SEI message is present for any picture of a CLVS of a particular layer and the first picture of the CLVS is an IRAP picture, an ambient viewing environment SEI message shall be present for that IRAP picture. The ambient viewing environment SEI message persists for the current layer in decoding order from the current picture until the end of the CLVS. All ambient viewing environment SEI messages that apply to the same CLVS shall have the same content.

ambient_illuminance specifies the environmental illuminance of the ambient viewing environment in units of 0.000 1 lux. ambient_illuminance shall not be equal to 0.

ambient_light_x and **ambient_light_y** specify the normalized x and y chromaticity coordinates, respectively, of the environmental ambient light in the nominal viewing environment in normalized increments of 0.000 02, according to the CIE 1931 definition of x and y as specified in ISO 11664-1 (see also ISO 11664-3 and CIE 15). The values of ambient_light_x and ambient_light_y shall be in the range of 0 to 50 000.

NOTE For example, the conditions identified in Rec. ITU-R BT.2035 (07/13) can be expressed using ambient_illuminance equal to 100 000 with background chromaticity indicating D_{65} (ambient_light_x equal to 15 635, ambient_light_y equal to 16 450), or optionally in some regions, background chromaticity indicating D_{93} (ambient_light_x equal to 14 155, ambient_light_y equal to 14 855).

D.3.40 Reserved SEI message semantics

The reserved SEI message consists of data reserved for future backward-compatible use by ITU-T | ISO/IEC. It is a requirement of bitstream conformance that bitstreams shall not contain reserved SEI messages until and unless the use of such messages has been specified by ITU-T | ISO/IEC. Decoders shall ignore reserved SEI messages.

Annex E (normative)

Video usability information

E.1 General

This annex specifies syntax and semantics of the VUI parameters of the SPSs.

VUI parameters are not required for constructing the luma or chroma samples by the decoding process. Conforming decoders are not required to process this information for output order conformance to this document (see Annex C and F.13 for the specification of output order conformance). Some VUI parameters are required to check bitstream conformance and for output timing decoder conformance.

In Annex E, specification for presence of VUI parameters is also satisfied when those parameters (or some subset of them) are conveyed to decoders (or to the HRD) by other means not specified in this document. When present in the bitstream, VUI parameters shall follow the syntax and semantics specified in this annex. When the content of VUI parameters is conveyed for the application by some means other than presence within the bitstream, the representation of the content of the VUI parameters is not required to use the same syntax specified in this annex. For the purpose of counting bits, only the appropriate bits that are actually present in the bitstream are counted.

E.2 VUI syntax

E.2.1 VUI parameters syntax

vui_parameters() {	Descriptor
aspect_ratio_info_present_flag	u(1)
if(aspect_ratio_info_present_flag) {	
aspect_ratio_idc	u(8)
if(aspect_ratio_idc == EXTENDED_SAR) {	
sar_width	u(16)
sar_height	u(16)
}	
}	
overscan_info_present_flag	u(1)
if(overscan_info_present_flag)	
overscan_appropriate_flag	u(1)
video_signal_type_present_flag	u(1)
if(video_signal_type_present_flag) {	
video_format	u(3)
video_full_range_flag	u(1)
colour_description_present_flag	u(1)
if(colour_description_present_flag) {	
colour_primaries	u(8)

transfer_characteristics	u(8)
matrix_coeffs	u(8)
}	
}	
chroma_loc_info_present_flag	u(1)
if(chroma_loc_info_present_flag) {	
chroma_sample_loc_type_top_field	ue(v)
chroma_sample_loc_type_bottom_field	ue(v)
}	
neutral_chroma_indication_flag	u(1)
field_seq_flag	u(1)
frame_field_info_present_flag	u(1)
default_display_window_flag	u(1)
if(default_display_window_flag) {	
def_disp_win_left_offset	ue(v)
def_disp_win_right_offset	ue(v)
def_disp_win_top_offset	ue(v)
def_disp_win_bottom_offset	ue(v)
}	
vui_timing_info_present_flag	u(1)
if(vui_timing_info_present_flag) {	
vui_num_units_in_tick	u(32)
vui_time_scale	u(32)
vui_poc_proportional_to_timing_flag	u(1)
if(vui_poc_proportional_to_timing_flag)	
vui_num_ticks_poc_diff_one_minus1	ue(v)
vui_hrd_parameters_present_flag	u(1)
if(vui_hrd_parameters_present_flag)	
hrd_parameters(1, sps_max_sub_layers_minus1)	
}	
bitstream_restriction_flag	u(1)
if(bitstream_restriction_flag) {	
tiles_fixed_structure_flag	u(1)
motion_vectors_over_pic_boundaries_flag	u(1)
restricted_ref_pic_lists_flag	u(1)
min_spatial_segmentation_idc	ue(v)
max_bytes_per_pic_denom	ue(v)
max_bits_per_min_cu_denom	ue(v)
log2_max_mv_length_horizontal	ue(v)

log2_max_mv_length_vertical	ue(v)
}	
}	

E.2.2 HRD parameters syntax

	Descriptor
hrd_parameters(commonInfPresentFlag, maxNumSubLayersMinus1) {	
if(commonInfPresentFlag) {	
nal_hrd_parameters_present_flag	u(1)
vcl_hrd_parameters_present_flag	u(1)
if(nal_hrd_parameters_present_flag vcl_hrd_parameters_present_flag) {	
sub_pic_hrd_params_present_flag	u(1)
if(sub_pic_hrd_params_present_flag) {	
tick_divisor_minus2	u(8)
du_cpb_removal_delay_increment_length_minus1	u(5)
sub_pic_cpb_params_in_pic_timing_sei_flag	u(1)
dpb_output_delay_du_length_minus1	u(5)
}	
bit_rate_scale	u(4)
cpb_size_scale	u(4)
if(sub_pic_hrd_params_present_flag)	
cpb_size_du_scale	u(4)
initial_cpb_removal_delay_length_minus1	u(5)
au_cpb_removal_delay_length_minus1	u(5)
dpb_output_delay_length_minus1	u(5)
}	
}	
for(i = 0; i <= maxNumSubLayersMinus1; i++) {	
fixed_pic_rate_general_flag[i]	u(1)
if(!fixed_pic_rate_general_flag[i])	
fixed_pic_rate_within_cvs_flag[i]	u(1)
if(fixed_pic_rate_within_cvs_flag[i])	
elemental_duration_in_tc_minus1[i]	ue(v)
else	
low_delay_hrd_flag[i]	u(1)
if(!low_delay_hrd_flag[i])	
cpb_cnt_minus1[i]	ue(v)
if(nal_hrd_parameters_present_flag)	
sub_layer_hrd_parameters(i)	
if(vcl_hrd_parameters_present_flag)	

sub_layer_hrd_parameters(i)	
}	
}	

E.2.3 Sub-layer HRD parameters syntax

sub_layer_hrd_parameters(subLayerId) {	Descriptor
for(i = 0; i <= CpbCnt; i++) {	
bit_rate_value_minus1[i]	ue(v)
cpb_size_value_minus1[i]	ue(v)
if(sub_pic_hrd_params_present_flag) {	
cpb_size_du_value_minus1[i]	ue(v)
bit_rate_du_value_minus1[i]	ue(v)
}	
cbr_flag[i]	u(1)
}	
}	

E.3 VUI semantics

E.3.1 VUI parameters semantics

aspect_ratio_info_present_flag equal to 1 specifies that **aspect_ratio_idc** is present. **aspect_ratio_info_present_flag** equal to 0 specifies that **aspect_ratio_idc** is not present.

aspect_ratio_idc specifies the value of the sample aspect ratio of the luma samples. Table E.1 shows the meaning of the code. When **aspect_ratio_idc** indicates EXTENDED_SAR, the sample aspect ratio is represented by **sar_width** : **sar_height**. When the **aspect_ratio_idc** syntax element is not present, the value of **aspect_ratio_idc** is inferred to be equal to 0. Values of **aspect_ratio_idc** in the range of 17 to 254, inclusive, are reserved for future use by ITU-T | ISO/IEC and shall not be present in bitstreams conforming to this version of this document. Decoders shall interpret values of **aspect_ratio_idc** in the range of 17 to 254, inclusive, as equivalent to the value 0.

Table E.1 — Interpretation of sample aspect ratio indicator

aspect_ratio_idc	Sample aspect ratio	(informative) Examples of use
0	Unspecified	
1	1:1 ("square")	7680x4320 16:9 frame without horizontal overscan 3840x2160 16:9 frame without horizontal overscan 1280x720 16:9 frame without horizontal overscan 1920x1080 16:9 frame without horizontal overscan (cropped from 1920x1088) 640x480 4:3 frame without horizontal overscan
2	12:11	720x576 4:3 frame with horizontal overscan 352x288 4:3 frame without horizontal overscan
3	10:11	720x480 4:3 frame with horizontal overscan 352x240 4:3 frame without horizontal overscan
4	16:11	720x576 16:9 frame with horizontal overscan 528x576 4:3 frame without horizontal overscan

5	40:33	720x480 16:9 frame with horizontal overscan 528x480 4:3 frame without horizontal overscan
6	24:11	352x576 4:3 frame without horizontal overscan 480x576 16:9 frame with horizontal overscan
7	20:11	352x480 4:3 frame without horizontal overscan 480x480 16:9 frame with horizontal overscan
8	32:11	352x576 16:9 frame without horizontal overscan
9	80:33	352x480 16:9 frame without horizontal overscan
10	18:11	480x576 4:3 frame with horizontal overscan
11	15:11	480x480 4:3 frame with horizontal overscan
12	64:33	528x576 16:9 frame without horizontal overscan
13	160:99	528x480 16:9 frame without horizontal overscan
14	4:3	1440x1080 16:9 frame without horizontal overscan
15	3:2	1280x1080 16:9 frame without horizontal overscan
16	2:1	960x1080 16:9 frame without horizontal overscan
17..254	Reserved	
255	EXTENDED_SAR	

NOTE 1 For the examples in Table E.1, the term “without horizontal overscan” refers to display processes in which the display area matches the area of the cropped decoded pictures and the term “with horizontal overscan” refers to display processes in which some parts near the left or right border of the cropped decoded pictures are not visible in the display area. As an example, the entry “720x576 4:3 frame with horizontal overscan” for aspect_ratio_idc equal to 2 refers to having an area of 704x576 luma samples (which has an aspect ratio of 4:3) of the cropped decoded frame (720x576 luma samples) that is visible in the display area.

NOTE 2 For the examples in Table E.1, the frame spatial resolutions shown as examples of use would be the dimensions of the conformance cropping window when field_seq_flag is equal to 0, and would have twice the height of the dimensions of the conformance cropping window when field_seq_flag is equal to 1.

sar_width indicates the horizontal size of the sample aspect ratio (in arbitrary units).

sar_height indicates the vertical size of the sample aspect ratio (in the same arbitrary units as sar_width).

sar_width and sar_height shall be relatively prime or equal to 0. When aspect_ratio_idc is equal to 0 or sar_width is equal to 0 or sar_height is equal to 0, the sample aspect ratio is unspecified in this document.

overscan_info_present_flag equal to 1 specifies that the overscan_appropriate_flag is present. When overscan_info_present_flag is equal to 0 or is not present, the preferred display method for the video signal is unspecified.

overscan_appropriate_flag equal to 1 indicates that the cropped decoded pictures output are suitable for display using overscan. overscan_appropriate_flag equal to 0 indicates that the cropped decoded pictures output contain visually important information in the entire region out to the edges of the conformance cropping window of the picture, such that the cropped decoded pictures output should not be displayed using overscan. Instead, they should be displayed using either an exact match between the display area and the conformance cropping window, or using underscan. As used in this paragraph, the term “overscan” refers to display processes in which some parts near the borders of the cropped decoded pictures are not visible in the display area. The term “underscan” describes display processes in which the entire cropped decoded pictures are visible in the display area, but they do not cover the

ISO/IEC 23008-2:2017(E)

entire display area. For display processes that neither use overscan nor underscan, the display area exactly matches the area of the cropped decoded pictures.

NOTE 3 For example, `overscan_appropriate_flag` equal to 1 might be used for entertainment television programming, or for a live view of people in a videoconference, and `overscan_appropriate_flag` equal to 0 might be used for computer screen capture or security camera content.

`video_signal_type_present_flag` equal to 1 specifies that `video_format`, `video_full_range_flag` and `colour_description_present_flag` are present. `video_signal_type_present_flag` equal to 0, specify that `video_format`, `video_full_range_flag` and `colour_description_present_flag` are not present.

NOTE 4 Some of the semantics of video signal type parameters associated with `video_signal_type_present_flag` equal to 1 are expressed in terms of the properties of source pictures prior to operation of the encoding process, which is outside the scope of this document. This is partly for historical reasons and due to the common general practice of how the indicated data is typically described in industry publications. The actual intent for providing this syntax in the bitstream is to assist decoding systems to properly interpret and make effective use of the decoded video pictures, e.g. for use by the display process (which is also outside the scope of this document, but for which having an indication of how the pictures should be interpreted is important).

`video_format` indicates the representation of the pictures as specified in Table E.2, before being coded in accordance with this document. When the `video_format` syntax element is not present, the value of `video_format` is inferred to be equal to 5. The values 6 and 7 for `video_format` are reserved for future use by ITU-T | ISO/IEC and shall not be present in bitstreams conforming to this version of this document. Decoders shall interpret the values 6 and 7 for `video_format` as equivalent to the value 5.

Table E.2 — Meaning of `video_format`

<code>video_format</code>	Meaning
0	Component
1	PAL
2	NTSC
3	SECAM
4	MAC
5	Unspecified video format

`video_full_range_flag` indicates the black level and range of the luma and chroma signals as derived from E'_Y , E'_{PB} , and E'_{PR} or E'_R , E'_G , and E'_B real-valued component signals.

When the `video_full_range_flag` syntax element is not present, the value of `video_full_range_flag` is inferred to be equal to 0.

`colour_description_present_flag` equal to 1 specifies that `colour primaries`, `transfer characteristics` and `matrix coeffs` are present. `colour_description_present_flag` equal to 0 specifies that `colour primaries`, `transfer characteristics` and `matrix coeffs` are not present.

`colour primaries` indicates the chromaticity coordinates of the source primaries as specified in Table E.3 in terms of the CIE 1931 definition of x and y as specified in ISO 11664-1.

When the `colour primaries` syntax element is not present, the value of `colour primaries` is inferred to be equal to 2 (the chromaticity is unspecified or is determined by the application). Values of `colour primaries` that are identified as reserved in Table E.3 are reserved for future use by ITU-T | ISO/IEC and shall not be present in bitstreams conforming to this version of this document. Decoders shall interpret reserved values of `colour primaries` as equivalent to the value 2.

Table E.3 — Colour primaries interpretation using colour_primaries syntax element

Value	Primaries			Informative remark
0	Reserved			For future use by ITU-T ISO/IEC
1	primary	x	y	Rec. ITU-R BT.709-6
	green	0.300	0.600	Rec. ITU-R BT.1361-0 conventional colour gamut system and extended colour gamut system (historical)
	blue	0.150	0.060	IEC 61966-2-1 sRGB or sYCC
	red	0.640	0.330	IEC 61966-2-4
	white D65	0.312 7	0.329 0	Society of Motion Picture and Television Engineers RP 177 (1993) Annex B
2	Unspecified			Image characteristics are unknown or are determined by the application.
3	Reserved			For future use by ITU-T ISO/IEC
4	primary	x	y	Rec. ITU-R BT.470-6 System M (historical)
	green	0.21	0.71	United States National Television System Committee 1953 Recommendation for transmission standards for colour television
	blue	0.14	0.08	United States Federal Communications Commission Title 47 Code of Federal Regulations (2003) 73.682 (a) (20)
	red	0.67	0.33	
	white C	0.310	0.316	
5	primary	x	y	Rec. ITU-R BT.470-6 System B, G (historical)
	green	0.29	0.60	Rec. ITU-R BT.601-6 625
	blue	0.15	0.06	Rec. ITU-R BT.1358-0 625 (historical)
	red	0.64	0.33	Rec. ITU-R BT.1700-0 625 PAL and 625 SECAM
	white D65	0.312 7	0.329 0	
6	primary	x	y	Rec. ITU-R BT.601-6 525
	green	0.310	0.595	Rec. ITU-R BT.1358-1 525 or 625 (historical)
	blue	0.155	0.070	Rec. ITU-R BT.1700-0 NTSC
	red	0.630	0.340	Society of Motion Picture and Television Engineers ST 170 (2004)
	white D65	0.312 7	0.329 0	(functionally the same as the value 7)
7	primary	x	y	Society of Motion Picture and Television Engineers ST 240 (1999)
	green	0.310	0.595	(functionally the same as the value 6)
	blue	0.155	0.070	
	red	0.630	0.340	
	white D65	0.312 7	0.329 0	
8	primary	x	y	Generic film (colour filters using Illuminant C)
	green	0.243	0.692 (Wratten 58)	
	blue	0.145	0.049 (Wratten 47)	
	red	0.681	0.319 (Wratten 25)	
	white C	0.310	0.316	
9	primary	x	y	Rec. ITU-R BT.2020-2
	green	0.170	0.797	
	blue	0.131	0.046	
	red	0.708	0.292	
	white D65	0.312 7	0.329 0	

10	primary green (Y) blue (Z) red (X) central white	x 0.0 0.0 1.0 1 ÷ 3	y 1.0 0.0 0.0 1 ÷ 3	Society of Motion Picture and Television Engineers ST 428-1 (2006) (CIE 1931 XYZ)
11	primary green blue red white	x 0.265 0.150 0.680 0.314	y 0.690 0.060 0.320 0.351	Society of Motion Picture and Television Engineers RP 431-2 (2011)
12	primary green blue red white D65	x 0.265 0.150 0.680 0.312 7	y 0.690 0.060 0.320 0.329 0	Society of Motion Picture and Television Engineers EG 432-1 (2010)
13..21	Reserved			For future use by ITU-T ISO/IEC
22	primary green blue red white D65	x 0.295 0.155 0.630 0.312 7	y 0.605 0.077 0.340 0.329 0	EBU Tech. 3213-E (1975)
23..255	Reserved			For future use by ITU-T ISO/IEC

transfer_characteristics, as specified in Table E.4, either indicates the reference opto-electronic transfer characteristic function of the source picture as a function of a source input linear optical intensity L_c with a nominal real-valued range of 0 to 1 or indicates the inverse of the reference electro-optical transfer characteristic function as a function of an output linear optical intensity L_o with a nominal real-valued range of 0 to 1. For interpretation of entries in Table E.4 that are expressed in terms of multiple curve segments parameterized by the variable α over a region bounded by the variable β or by the variables β and γ , the values of α and β are defined to be the positive constants necessary for the curve segments that meet at the value β to have continuity of value and continuity of slope at the value β , and the value of γ , when applicable, is defined to be the positive constant necessary for the associated curve segments to meet at the value γ . For example, for transfer_characteristics equal to 1, 6, 11, 14, or 15, α has the value $1 + 5.5 * \beta = 1.099\ 296\ 826\ 809\ 442\dots$ and β has the value 0.018 053 968 510 807....

When video_full_range_flag is equal to 1 and either or both of the following conditions apply, transfer_characteristics shall not be equal to 18:

- BitDepth_v is less than 10.
- chroma_format_idc is not equal to 0 (monochrome) and BitDepth_c is less than 10.

When the transfer_characteristics syntax element is not present, the value of transfer_characteristics is inferred to be equal to 2 (the transfer characteristics are unspecified or are determined by the application). Values of transfer_characteristics that are identified as reserved in Table E.4 are reserved for future use by ITU-T | ISO/IEC and shall not be present in bitstreams conforming to this version of this document. Decoders shall interpret reserved values of transfer_characteristics as equivalent to the value 2.

NOTE 5 As indicated in Table E.4, some values of transfer_characteristics are defined in terms of a reference opto-electronic transfer characteristic function and others are defined in terms of a reference electro-optical transfer characteristic function, according to the convention that has been applied in other Specifications. In the cases of Rec. ITU-R BT.709-6 and Rec. ITU-R BT.2020-2 (which may be indicated by transfer_characteristics equal to 1, 6, 14, or 15), although the value is defined in terms of a reference opto-electronic transfer characteristic function, a suggested corresponding reference electro-optical transfer characteristic function for flat panel displays used in HDTV studio production has been specified in Rec. ITU-R BT.1886-0.

Table E.4 — Transfer characteristics interpretation using transfer_characteristics syntax element

Value	Transfer characteristic	Informative remark
0	Reserved	For future use by ITU-T ISO/IEC
1	$V = \alpha * L_c^{0.45} - (\alpha - 1)$ for $1 \geq L_c \geq \beta$ $V = 4.500 * L_c$ for $\beta > L_c \geq 0$	Rec. ITU-R BT.709-6 Rec. ITU-R BT.1361-0 conventional colour gamut system (historical) (functionally the same as the values 6, 14, and 15)
2	Unspecified	Image characteristics are unknown or are determined by the application.
3	Reserved	For future use by ITU-T ISO/IEC
4	Assumed display gamma 2.2	Rec. ITU-R BT.470-6 System M (historical) United States National Television System Committee 1953 Recommendation for transmission standards for colour television United States Federal Communications Commission Title 47 Code of Federal Regulations (2003) 73.682 (a) (20) Rec. ITU-R BT.1700-0 625 PAL and 625 SECAM
5	Assumed display gamma 2.8	Rec. ITU-R BT.470-6 System B, G (historical)
6	$V = \alpha * L_c^{0.45} - (\alpha - 1)$ for $1 \geq L_c \geq \beta$ $V = 4.500 * L_c$ for $\beta > L_c \geq 0$	Rec. ITU-R BT.601-6 525 or 625 Rec. ITU-R BT.1358-1 525 or 625 (historical) Rec. ITU-R BT.1700-0 NTSC Society of Motion Picture and Television Engineers ST 170 (2004) (functionally the same as the values 1, 14, and 15)
7	$V = \alpha * L_c^{0.45} - (\alpha - 1)$ for $1 \geq L_c \geq \beta$	Society of Motion Picture and

ISO/IEC 23008-2:2017(E)

Value	Transfer characteristic	Informative remark
	$V = 4.0 * L_c$ for $\beta > L_c \geq 0$	Television Engineers ST 240 (1999)
8	$V = L_c$ for all values of L_c	Linear transfer characteristics
9	$V = 1.0 + \text{Log}_{10}(L_c) \div 2$ for $1 \geq L_c \geq 0.01$ $V = 0.0$ for $0.01 > L_c \geq 0$	Logarithmic transfer characteristic (100:1 range)
10	$V = 1.0 + \text{Log}_{10}(L_c) \div 2.5$ for $1 \geq L_c \geq \text{Sqrt}(10) \div 1\,000$ $V = 0.0$ for $\text{Sqrt}(10) \div 1\,000 > L_c \geq 0$	Logarithmic transfer characteristic (100 * Sqrt(10) : 1 range)
11	$V = \alpha * L_c^{0.45} - (\alpha - 1)$ for $L_c \geq \beta$ $V = 4.500 * L_c$ for $\beta > L_c > -\beta$ $V = -\alpha * (-L_c)^{0.45} + (\alpha - 1)$ for $-\beta \geq L_c$	IEC 61966-2-4
12	$V = \alpha * L_c^{0.45} - (\alpha - 1)$ for $1.33 > L_c \geq \beta$ $V = 4.500 * L_c$ for $\beta > L_c \geq -\gamma$ $V = -(\alpha * (-4 * L_c)^{0.45} - (\alpha - 1)) \div 4$ for $-\gamma > L_c \geq -0.25$	Rec. ITU-R BT.1361-0 extended colour gamut system (historical)
13	$V = \alpha * L_c(1 \div 2.4) - (\alpha - 1)$ for $1 \geq L_c \geq \beta$ $V = 12.92 * L_c$ for $\beta > L_c \geq 0$	IEC 61966-2-1 sRGB or sYCC
14	$V = \alpha * L_c^{0.45} - (\alpha - 1)$ for $1 \geq L_c \geq \beta$ $V = 4.500 * L_c$ for $\beta > L_c \geq 0$	Rec. ITU-R BT.2020-2 (functionally the same as the values 1, 6, and 15)
15	$V = \alpha * L_c^{0.45} - (\alpha - 1)$ for $1 \geq L_c \geq \beta$ $V = 4.500 * L_c$ for $\beta > L_c \geq 0$	Rec. ITU-R BT.2020-2 (functionally the same as the values 1, 6, and 14)
16	$V = ((c_1 + c_2 * L_o^n) \div (1 + c_3 * L_o^n))^m$ for all values of L_o $c_1 = c_3 - c_2 + 1 = 3\,424 \div 4\,096 = 0.835\,937\,5$ $c_2 = 32 * 2\,413 \div 4\,096 = 18.851\,562\,5$ $c_3 = 32 * 2\,392 \div 4\,096 = 18.687\,5$ $m = 128 * 2\,523 \div 4\,096 = 78.843\,75$ $n = 0.25 * 2\,610 \div 4\,096 = 0.159\,301\,757\,812\,5$ for which L_o equal to 1 for peak white is ordinarily intended to correspond to a reference output luminance level of 10 000 candelas per square metre	Society of Motion Picture and Television Engineers ST 2084 (2014) for 10, 12, 14, and 16-bit systems
17	$V = (48 * L_o \div 52.37)(1 \div 2.6)$ for all values of L_o for which L_o equal to 1 for peak white is ordinarily intended to correspond to a reference output luminance level of 48 candelas per square metre	Society of Motion Picture and Television Engineers ST 428-1 (2006)
18	$V = a * \text{Ln}(12 * L_c - b) + c$ for $1 \geq L_c > 1 \div 12$ $V = \text{Sqrt}(3) * L_c^{0.5}$ for $1 \div 12 \geq L_c \geq 0$ $a = 0.178\,832\,77, b = 0.284\,668\,92, c = 0.559\,910\,73$	Association of Radio Industries and Businesses (ARIB) STD-B67
19..255	Reserved	For future use by ITU-T ISO/IEC

NOTE 6 For transfer_characteristics equal to 18, the formulae given in Table E.4 are normalized for a source input linear optical intensity L_c with a nominal real-valued range of 0 to 1. An alternative scaling that is

mathematically equivalent is used in ARIB STD-B67 with the source input linear optical intensity having a nominal real-valued range of 0 to 12.

matrix_coeffs describes the matrix coefficients used in deriving luma and chroma signals from the green, blue, and red, or Y, Z, and X primaries, as specified in Table E.5.

matrix_coeffs shall not be equal to 0 unless one or more of the following conditions are true:

- BitDepth_C is equal to BitDepth_Y.
- chroma_format_idc is equal to 3 (4:4:4 chroma format).

The specification of the use of matrix_coeffs equal to 0 under all other conditions is reserved for future use by ITU-T | ISO/IEC.

matrix_coeffs shall not be equal to 8 unless one of the following conditions is true:

- BitDepth_C is equal to BitDepth_Y,
- BitDepth_C is equal to BitDepth_Y + 1 and chroma_format_idc is equal to 3 (4:4:4 chroma format).

The specification of the use of matrix_coeffs equal to 8 under all other conditions is reserved for future use by ITU-T | ISO/IEC.

When the matrix_coeffs syntax element is not present, the value of matrix_coeffs is inferred to be equal to 2 (unspecified).

The interpretation of matrix_coeffs, together with colour_primaries and transfer_characteristics, is specified by the equations below.

NOTE 7 For purposes of YZX representation when matrix_coeffs is equal to 0, the symbols R, G, and B are substituted for X, Y, and Z, respectively, in the following descriptions of Formulae (E-1) to (E-3), (E-7) to (E-9), (E-16) to (E-18), and (E-31) to (E-33).

E_R , E_G , and E_B are defined as “linear-domain” real-valued signals based on the indicated colour primaries before application of the transfer characteristics function. The application of the transfer characteristics function is denoted by $(x)'$ for an argument x . The signals E'_R , E'_G , and E'_B are determined by application of the transfer characteristics function as follows:

$$E'_R = (E_R)' \quad (\text{E-1})$$

$$E'_G = (E_G)' \quad (\text{E-2})$$

$$E'_B = (E_B)' \quad (\text{E-3})$$

The range of E'_R , E'_G , and E'_B is specified as follows:

- If transfer_characteristics is not equal to 11 or 12, E'_R , E'_G , and E'_B are real numbers with values in the range of 0 to 1 inclusive.
- Otherwise, (transfer_characteristics is equal to 11 or 12), E'_R , E'_G and E'_B are real numbers with a larger range not specified in this document.

Nominal white is specified as having E'_R equal to 1, E'_G equal to 1, and E'_B equal to 1.

Nominal black is specified as having E'_R equal to 0, E'_G equal to 0, and E'_B equal to 0.

The interpretation of matrix_coeffs is specified as follows:

- If video_full_range_flag is equal to 0, the following apply:
 - If matrix_coeffs is equal to 1, 4, 5, 6, 7, 9, 10, 11, 12, or 13, the following formulae apply:

$$Y = \text{Clip1}_Y(\text{Round}((1 \ll (\text{BitDepth}_Y - 8)) * (219 * E'_Y + 16))) \quad (\text{E-4})$$

$$Cb = \text{Clip1}_C(\text{Round}((1 \ll (\text{BitDepth}_C - 8)) * (224 * E'_{PB} + 128))) \quad (\text{E-5})$$

$$Cr = \text{Clip1}_C(\text{Round}((1 \ll (\text{BitDepth}_C - 8)) * (224 * E'_{PR} + 128))) \quad (\text{E-6})$$

— Otherwise, if `matrix_coeffs` is equal to 0 or 8, the following formulae apply:

$$R = \text{Clip1}_Y((1 \ll (\text{BitDepth}_Y - 8)) * (219 * E'_R + 16)) \quad (\text{E-7})$$

$$G = \text{Clip1}_Y((1 \ll (\text{BitDepth}_Y - 8)) * (219 * E'_G + 16)) \quad (\text{E-8})$$

$$B = \text{Clip1}_Y((1 \ll (\text{BitDepth}_Y - 8)) * (219 * E'_B + 16)) \quad (\text{E-9})$$

— Otherwise, if `matrix_coeffs` is equal to 2, the interpretation of the `matrix_coeffs` syntax element is unknown or is determined by the application.

— Otherwise (`matrix_coeffs` is not equal to 0, 1, 2, 4, 5, 6, 7, 8, 9, 10, 11, 12, or 13), the interpretation of the `matrix_coeffs` syntax element is reserved for future definition by ITU-T | ISO/IEC.

— Otherwise (`video_full_range_flag` is equal to 1), the following apply:

— If `matrix_coeffs` is equal to 1, 4, 5, 6, 7, 9, 10, 11, 12, or 13, the following formulae apply:

— If `transfer_characteristics` is not equal to 18, the following formulae apply:

$$Y = \text{Clip1}_Y(\text{Round}(((1 \ll \text{BitDepth}_Y) - 1) * E'_Y)) \quad (\text{E-10})$$

$$Cb = \text{Clip1}_C(\text{Round}(((1 \ll \text{BitDepth}_C) - 1) * E'_{PB} + (1 \ll (\text{BitDepth}_C - 1)))) \quad (\text{E-11})$$

$$Cr = \text{Clip1}_C(\text{Round}(((1 \ll \text{BitDepth}_C) - 1) * E'_{PR} + (1 \ll (\text{BitDepth}_C - 1)))) \quad (\text{E-12})$$

— Otherwise (`transfer_characteristics` is equal to 18), the following formulae apply:

$$Y = \text{Clip3}(0, 1023 * (1 \ll (\text{BitDepth}_Y - 10)), \text{Round}((1 \ll \text{BitDepth}_Y) * E'_Y)) \quad (\text{E-13})$$

$$Cb = \text{Clip3}(0, 1023 * (1 \ll (\text{BitDepth}_C - 10)), \text{Round}((1 \ll \text{BitDepth}_C) * (E'_{PB} + 0.5))) \quad (\text{E-14})$$

$$Cr = \text{Clip3}(0, 1023 * (1 \ll (\text{BitDepth}_C - 10)), \text{Round}((1 \ll \text{BitDepth}_C) * (E'_{PR} + 0.5))) \quad (\text{E-15})$$

— Otherwise, if `matrix_coeffs` is equal to 0 or 8, the following apply:

— If `transfer_characteristics` is not equal to 18, the following formulae apply:

$$R = \text{Clip1}_Y(((1 \ll \text{BitDepth}_Y) - 1) * E'_R) \quad (\text{E-16})$$

$$G = \text{Clip1}_Y(((1 \ll \text{BitDepth}_Y) - 1) * E'_G) \quad (\text{E-17})$$

$$B = \text{Clip1}_Y(((1 \ll \text{BitDepth}_Y) - 1) * E'_B) \quad (\text{E-18})$$

— Otherwise (`transfer_characteristics` is equal to 18), the following formulae apply:

$$R = \text{Clip3}(0, 1023 * (1 \ll (\text{BitDepth}_Y - 10)), (1 \ll \text{BitDepth}_Y) * E'_R) \quad (\text{E-19})$$

$$G = \text{Clip3}(0, 1023 * (1 \ll (\text{BitDepth}_Y - 10)), (1 \ll \text{BitDepth}_Y) * E'_G) \quad (\text{E-20})$$

$$B = \text{Clip3}(0, 1023 * (1 \ll (\text{BitDepth}_Y - 10)), (1 \ll \text{BitDepth}_Y) * E'_B) \quad (\text{E-21})$$

- Otherwise, if matrix_coefs is equal to 2, the interpretation of the matrix_coefs syntax element is unknown or is determined by the application.
- Otherwise (matrix_coefs is not equal to 0, 1, 2, 4, 5, 6, 7, 8, 9, 10, 11, 12 or 13), the interpretation of the matrix_coefs syntax element is reserved for future definition by ITU-T | ISO/IEC. Reserved values for matrix_coefs shall not be present in bitstreams conforming to this version of this document. Decoders shall interpret reserved values of matrix_coefs as equivalent to the value 2.

NOTE 8 The clipping shown using the Clip3() function in the formulae above for interpretation of transfer_characteristics equal to 16 or 18 when video_full_range_flag is equal to 1 is described herein only to show the nominal operating range of the associated signals, not to suggest that clipping to this range should be applied to the colour component sample values of the decoded pictures. When the bit depth for the luma or chroma samples of the decoded picture is greater than 10, the clipping applied to the decoded sample values by the decoding process specified in this document uses a larger upper limit.

It is a requirement of bitstream conformance to this version of this document that when colour_primaries is not equal to 1, 4, 5, 6, 7, 8, 9, 10, 11, 12, or 22, matrix_coefs shall not be equal to 12 or 13.

When matrix_coefs is equal to 1, 4, 5, 6, 7, 9, 10, 11, 12, or 13, the constants K_B and K_R are specified as follows:

- If matrix_coefs is not equal to 12 or 13, the constants K_B and K_R are specified in Table E.5.
- Otherwise (matrix_coefs is equal to 12 or 13), the constants K_R and K_B are computed as follows, using the chromaticity coordinates (x_R, y_R) , (x_G, y_G) , (x_B, y_B) , and (x_W, y_W) specified by Table E.3 for the colour_primaries syntax element for the red, green, blue, and white colour primaries, respectively.

$$K_R = \frac{y_R * (x_W * (y_G * z_B - y_B * z_G)) + y_W * (x_B * z_G - x_G * z_B) + z_W * (x_G * y_B - x_B * y_G)}{y_W * (x_R * (y_G * z_B - y_B * z_G)) + x_G * (y_B * z_R - y_R * z_B) + x_B * (y_R * z_G - y_G * z_R)} \quad (\text{E-22})$$

$$K_B = \frac{y_B * (x_W * (y_R * z_G - y_G * z_R)) + y_W * (x_G * z_R - x_R * z_G) + z_W * (x_R * y_G - x_G * y_R)}{y_W * (x_R * (y_G * z_B - y_B * z_G)) + x_G * (y_B * z_R - y_R * z_B) + x_B * (y_R * z_G - y_G * z_R)} \quad (\text{E-23})$$

where the values of z_R , z_G , z_B , and z_W , are given by:

$$z_R = 1 - (x_R + y_R) \quad (\text{E-24})$$

$$z_G = 1 - (x_G + y_G) \quad (\text{E-25})$$

$$z_B = 1 - (x_B + y_B) \quad (\text{E-26})$$

$$z_W = 1 - (x_W + y_W) \quad (\text{E-27})$$

The variables E'_Y , E'_{PB} , and E'_{PR} (for matrix_coefs not equal to 0 or 8) or Y , C_b , and C_r (for matrix_coefs equal to 0 or 8) are specified as follows:

- If matrix_coefs is not equal to 0, 8, 10, 11, or 13, the following formulae apply:

$$E'_Y = K_R * E'_R + (1 - K_R - K_B) * E'_G + K_B * E'_B \quad (\text{E-28})$$

$$E'_{PB} = 0.5 * (E'_B - E'_Y) \div (1 - K_B) \quad (\text{E-29})$$

ISO/IEC 23008-2:2017(E)

$$E'_{PR} = 0.5 * (E'_{R} - E'_{Y}) \div (1 - K_R) \quad (E-30)$$

NOTE 9 E'_{Y} is a real number with the value 0 associated with nominal black and the value 1 associated with nominal white. E'_{PB} and E'_{PR} are real numbers with the value 0 associated with both nominal black and nominal white. When transfer_characteristics is not equal to 11 or 12, E'_{Y} is a real number with values in the range of 0 to 1 inclusive. When transfer_characteristics is not equal to 11 or 12, E'_{PB} and E'_{PR} are real numbers with values in the range of -0.5 to 0.5 inclusive. When transfer_characteristics is equal to 11 or 12, E'_{Y} , E'_{PB} and E'_{PR} are real numbers with a larger range not specified in this document.

— Otherwise, if matrix_coeffs is equal to 0, the following formulae apply:

$$Y = \text{Round}(G) \quad (E-31)$$

$$Cb = \text{Round}(B) \quad (E-32)$$

$$Cr = \text{Round}(R) \quad (E-33)$$

— Otherwise, if matrix_coeffs is equal to 8, the following apply:

— If BitDepth_c is equal to BitDepth_y, the following formulae apply:

$$Y = \text{Round}(0.5 * G + 0.25 * (R + B)) \quad (E-34)$$

$$Cb = \text{Round}(0.5 * G - 0.25 * (R + B)) + (1 \ll (\text{BitDepth}_c - 1)) \quad (E-35)$$

$$Cr = \text{Round}(0.5 * (R - B)) + (1 \ll (\text{BitDepth}_c - 1)) \quad (E-36)$$

NOTE 10 In this case, for purposes of the YCgCo nomenclature used in Table E.5, Cb and Cr of Formulae (E-35) and (E-36) may be referred to as Cg and Co, respectively. An appropriate inverse conversion for Formulae (E-34) to (E-36) is as follows:

$$t = Y - (Cb - (1 \ll (\text{BitDepth}_c - 1))) \quad (E-37)$$

$$G = \text{Clip}_{1Y}(Y + (Cb - (1 \ll (\text{BitDepth}_c - 1)))) \quad (E-38)$$

$$B = \text{Clip}_{1Y}(t - (Cr - (1 \ll (\text{BitDepth}_c - 1)))) \quad (E-39)$$

$$R = \text{Clip}_{1Y}(t + (Cr - (1 \ll (\text{BitDepth}_c - 1)))) \quad (E-40)$$

— Otherwise (BitDepth_c is not equal to BitDepth_y), the following formulae apply:

$$Cr = \text{Round}(R) - \text{Round}(B) + (1 \ll (\text{BitDepth}_c - 1)) \quad (E-41)$$

$$t = \text{Round}(B) + ((Cr - (1 \ll (\text{BitDepth}_c - 1))) \gg 1) \quad (E-42)$$

$$Cb = \text{Round}(G) - t + (1 \ll (\text{BitDepth}_c - 1)) \quad (E-43)$$

$$Y = t + ((Cb - (1 \ll (\text{BitDepth}_c - 1))) \gg 1) \quad (E-44)$$

NOTE 11 In this case, for purposes of the YCgCo nomenclature used in Table E.5, Cb and Cr of Formulae (E-43) and (E-41) may be referred to as Cg and Co, respectively. An appropriate inverse conversion for Formulae (E-41) to (E-44) is as follows.

$$t = Y - ((Cb - (1 \ll (\text{BitDepth}_c - 1))) \gg 1) \quad (E-45)$$

$$G = \text{Clip}_{1Y}(t + (Cb - (1 \ll (\text{BitDepth}_c - 1)))) \quad (E-46)$$

$$B = \text{Clip}_{1Y}(t - ((Cr - (1 \ll (\text{BitDepth}_c - 1))) \gg 1)) \quad (E-47)$$

$$R = \text{Clip}_{1Y}(B + (C_r - (1 \ll (\text{BitDepth}_c - 1)))) \quad (\text{E-48})$$

- Otherwise, if `matrix_coeffs` is equal to 10 or 13, the signal E'_Y is determined by application of the transfer characteristics function as follows, and Formulae (E-51) to (E-58) apply for specification of the signals E'_{PB} and E'_{PR} :

$$E_Y = K_R * E_R + (1 - K_R - K_B) * E_G + K_B * E_B \quad (\text{E-49})$$

$$E'_Y = (E_Y)' \quad (\text{E-50})$$

NOTE 12 In this case, E_Y is defined from the “linear-domain” signals for E_R , E_G , and E_B , prior to application of the transfer characteristics function, which is then applied to produce the signal E'_Y . E_Y and E'_Y are real values with the value 0 associated with nominal black and the value 1 associated with nominal white.

$$E'_{PB} = (E'_B - E'_Y) \div (2 * N_B) \text{ for } -N_B \leq E'_B - E'_Y \leq 0 \quad (\text{E-51})$$

$$E'_{PB} = (E'_B - E'_Y) \div (2 * P_B) \text{ for } 0 < E'_B - E'_Y \leq P_B \quad (\text{E-52})$$

$$E'_{PR} = (E'_R - E'_Y) \div (2 * N_R) \text{ for } -N_R \leq E'_R - E'_Y \leq 0 \quad (\text{E-53})$$

$$E'_{PR} = (E'_R - E'_Y) \div (2 * P_R) \text{ for } 0 < E'_R - E'_Y \leq P_R \quad (\text{E-54})$$

where the constants N_B , P_B , N_R , and P_R are determined by application of the transfer characteristics function to expressions involving the constants K_B and K_R as follows:

$$N_B = (1 - K_B)' \quad (\text{E-55})$$

$$P_B = 1 - (K_B)' \quad (\text{E-56})$$

$$N_R = (1 - K_R)' \quad (\text{E-57})$$

$$P_R = 1 - (K_R)' \quad (\text{E-58})$$

- Otherwise (`matrix_coeffs` is equal to 11), the following formulae apply:

$$E'_Y = E'_G \quad (\text{E-59})$$

$$E'_{PB} = 0.5 * (0.986\ 566 * E'_B - E'_Y) \quad (\text{E-60})$$

$$E'_{PR} = 0.5 * (E'_R - 0.991\ 902 * E'_Y) \quad (\text{E-61})$$

NOTE 13 In this case, for purposes of the $Y'D'_zD'_x$ nomenclature used in Table E.5, E'_{PB} may be referred to as D'_z and E'_{PR} may be referred to as D'_x .

Table E.5 — Matrix coefficients interpretation using matrix_coeffs syntax element

Value	Matrix	Informative remark
0	Identity	The identity matrix. Typically used for GBR (often referred to as RGB); however, may also be used for YZX (often referred to as XYZ) IEC 61966-2-1 sRGB Society of Motion Picture and Television Engineers ST 428-1 (2006) See Formulae (E-31) to (E-33)
1	$K_R = 0.212\ 6; K_B = 0.072\ 2$	ITU-R Rec. BT.709-6 ITU-R Rec. BT.1361-0 conventional colour gamut system and extended colour gamut system (historical) IEC 61966-2-1 sYCC IEC 61966-2-4 xvYCC ₇₀₉ Society of Motion Picture and Television Engineers RP 177 (1993) Annex B See Formulae (E-28) to (E-30)
2	Unspecified	Image characteristics are unknown or are determined by the application.
3	Reserved	For future use by ITU-T ISO/IEC
4	$K_R = 0.30; K_B = 0.11$	United States Federal Communications Commission Title 47 Code of Federal Regulations (2003) 73.682 (a) (20) See Formulae (E-28) to (E-30)
5	$K_R = 0.299; K_B = 0.114$	ITU-R Rec. BT.470-6 System B, G (historical) ITU-R Rec. BT.601-6 625 ITU-R Rec. BT.1358-0 625 (historical) ITU-R Rec. BT.1700-0 625 PAL and 625 SECAM IEC 61966-2-4 xvYCC ₆₀₁ (functionally the same as the value 6) See Formulae (E-28) to (E-30)
6	$K_R = 0.299; K_B = 0.114$	ITU-R Rec. BT.601-6 525 ITU-R Rec. BT.1358-1 525 or 625 (historical) ITU-R Rec. BT.1700-0 NTSC Society of Motion Picture and Television Engineers ST 170 (2004) (functionally the same as the value 5) See Formulae (E-28) to (E-30)
7	$K_R = 0.212; K_B = 0.087$	Society of Motion Picture and Television Engineers ST 240 (1999) See Formulae (E-28) to (E-30)
8	YCgCo	See Formulae (E-34) to (E-48)
9	$K_R = 0.262\ 7; K_B = 0.059\ 3$	Rec. ITU-R BT.2020-2 non-constant luminance system See Formulae (E-28) to (E-30)
10	$K_R = 0.262\ 7; K_B = 0.059\ 3$	Rec. ITU-R BT.2020-2 constant luminance system See Formulae (E-49) to (E-58)
11	$Y'D'zD'_x$	Society of Motion Picture and Television Engineers ST 2085 (2015) See Formulae (E-59) to (E-61)

12	See Formulae (E-22) to (E-27)	Chromaticity-derived non-constant luminance system See Formulae (E-28) to (E-30)
13	See Formulae (E-22) to (E-27)	Chromaticity-derived constant luminance system See Formulae (E-49) to (E-58)
14..255	Reserved	For future use by ITU-T ISO/IEC

chroma_loc_info_present_flag equal to 1 specifies that **chroma_sample_loc_type_top_field** and **chroma_sample_loc_type_bottom_field** are present. **chroma_loc_info_present_flag** equal to 0 specifies that **chroma_sample_loc_type_top_field** and **chroma_sample_loc_type_bottom_field** are not present.

When **chroma_format_idc** is not equal to 1, **chroma_loc_info_present_flag** should be equal to 0.

chroma_sample_loc_type_top_field and **chroma_sample_loc_type_bottom_field** specify the location of chroma samples as follows:

- If **chroma_format_idc** is equal to 1 (4:2:0 chroma format), **chroma_sample_loc_type_top_field** and **chroma_sample_loc_type_bottom_field** specify the location of chroma samples for the top field and the bottom field, respectively, as shown in Figure E.1.
- Otherwise (**chroma_format_idc** is not equal to 1), the values of the syntax elements **chroma_sample_loc_type_top_field** and **chroma_sample_loc_type_bottom_field** shall be ignored. When **chroma_format_idc** is equal to 2 (4:2:2 chroma format) or 3 (4:4:4 chroma format), the location of chroma samples is specified in 6.2. When **chroma_format_idc** is equal to 0, there is no chroma sample array.

The value of **chroma_sample_loc_type_top_field** and **chroma_sample_loc_type_bottom_field** shall be in the range of 0 to 5, inclusive. When the **chroma_sample_loc_type_top_field** and **chroma_sample_loc_type_bottom_field** are not present, the values of **chroma_sample_loc_type_top_field** and **chroma_sample_loc_type_bottom_field** are inferred to be equal to 0.

NOTE 14 When coding progressive source material, **chroma_sample_loc_type_top_field** and **chroma_sample_loc_type_bottom_field** should have the same value.

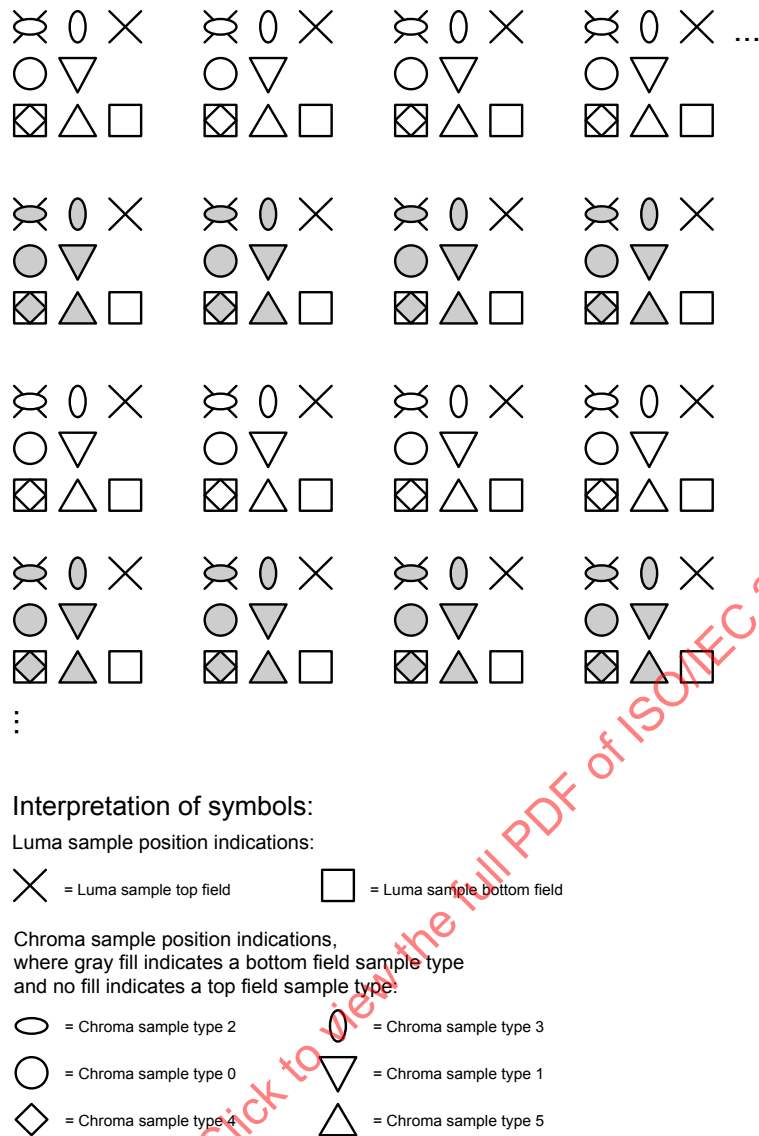

Figure E.1 — Location of chroma samples for top and bottom fields for chroma_format_idc equal to 1 (4:2:0 chroma format) as a function of chroma_sample_loc_type_top_field and chroma_sample_loc_type_bottom_field

neutral_chroma_indication_flag equal to 1 indicates that the value of all decoded chroma samples is equal to $1 \ll (\text{BitDepth}_c - 1)$. **neutral_chroma_indication_flag** equal to 0 provides no indication of decoded chroma sample values. When **neutral_chroma_indication_flag** is equal to 1, it is a requirement of bitstream conformance that the value of all decoded chroma samples produced by the decoding process shall be equal to $1 \ll (\text{BitDepth}_c - 1)$. When **neutral_chroma_indication_flag** is not present, it is inferred to be equal to 0.

NOTE 15 When **neutral_chroma_indication_flag** is equal to 1, it is not necessary for the decoder to apply the specified decoding process in order to determine the value of the decoded chroma samples.

field_seq_flag equal to 1 indicates that the CVS conveys pictures that represent fields, and specifies that a picture timing SEI message shall be present in every access unit of the current CVS. **field_seq_flag** equal to 0 indicates that the CVS conveys pictures that represent frames and that a picture timing SEI message may or may not be present in any access unit of the current CVS. When **field_seq_flag** is not present, it is inferred to be equal to 0. When **general_frame_only_constraint_flag** is equal to 1, the value of **field_seq_flag** shall be equal to 0.

NOTE 16 The specified decoding process does not treat access units conveying pictures that represent fields or frames differently. A sequence of pictures that represent fields would therefore be coded with the picture dimensions of an individual field. For example, access units containing pictures that represent 1080i fields would commonly have cropped output dimensions of 1 920 x 540, while the sequence picture rate would commonly express the rate of the source fields (typically between 50 Hz and 60 Hz), instead of the source frame rate (typically between 25 Hz and 30 Hz).

frame_field_info_present_flag equal to 1 specifies that picture timing SEI messages are present for every picture and include the `pic_struct`, `source_scan_type`, and `duplicate_flag` syntax elements. `frame_field_info_present_flag` equal to 0 specifies that the `pic_struct` syntax element is not present in picture timing SEI messages.

When `frame_field_info_present_flag` is present and either or both of the following conditions are true, `frame_field_info_present_flag` shall be equal to 1:

- `field_seq_flag` is equal to 1.
- `general_progressive_source_flag` is equal to 1 and `general_interlaced_source_flag` is equal to 1.

When `frame_field_info_present_flag` is not present, its value is inferred as follows:

- If `general_progressive_source_flag` is equal to 1 and `general_interlaced_source_flag` is equal to 1, `frame_field_info_present_flag` is inferred to be equal to 1.
- Otherwise, `frame_field_info_present_flag` is inferred to be equal to 0.

default_display_window_flag equal to 1 indicates that the default display window parameters follow next in the VUI. `default_display_window_flag` equal to 0 indicates that the default display window parameters are not present. The default display window parameters identify the area that is within the conformance cropping window and that is suggested to be displayed in the absence of any alternative indication (provided within the bitstream or by external means not specified in this document) of preferred display characteristics.

def_disp_win_left_offset, **def_disp_win_right_offset**, **def_disp_win_top_offset**, and **def_disp_win_bottom_offset** specify the samples of the pictures in the CVS that are within the default display window, in terms of a rectangular region specified in picture coordinates for display. When `default_display_window_flag` is equal to 0, the values of `def_disp_win_left_offset`, `def_disp_win_right_offset`, `def_disp_win_top_offset`, and `def_disp_win_bottom_offset` are inferred to be equal to 0.

The following variables are derived from the default display window parameters:

$$\text{leftOffset} = \text{conf_win_left_offset} + \text{def_disp_win_left_offset} \quad (\text{E-62})$$

$$\text{rightOffset} = \text{conf_win_right_offset} + \text{def_disp_win_right_offset} \quad (\text{E-63})$$

$$\text{topOffset} = \text{conf_win_top_offset} + \text{def_disp_win_top_offset} \quad (\text{E-64})$$

$$\text{bottomOffset} = \text{conf_win_bottom_offset} + \text{def_disp_win_bottom_offset} \quad (\text{E-65})$$

The default display window contains the luma samples with horizontal picture coordinates from $\text{SubWidthC} * \text{leftOffset}$ to $\text{pic_width_in_luma_samples} - (\text{SubWidthC} * \text{rightOffset} + 1)$ and vertical picture coordinates from $\text{SubHeightC} * \text{topOffset}$ to $\text{pic_height_in_luma_samples} - (\text{SubHeightC} * \text{bottomOffset} + 1)$, inclusive.

The value of $\text{SubWidthC} * (\text{leftOffset} + \text{rightOffset})$ shall be less than `pic_width_in_luma_samples`, and the value of $\text{SubHeightC} * (\text{topOffset} + \text{bottomOffset})$ shall be less than `pic_height_in_luma_samples`.

When `ChromaArrayType` is not equal to 0, the corresponding specified samples of the two chroma arrays are the samples having picture coordinates $(x / \text{SubWidthC}, y / \text{SubHeightC})$, where (x, y) are the picture coordinates of the specified luma samples.

vui_timing_info_present_flag equal to 1 specifies that `vui_num_units_in_tick`, `vui_time_scale`, `vui_poc_proportional_to_timing_flag`, and `vui_hrd_parameters_present_flag` are present in the `vui_parameters()` syntax structure. `vui_timing_info_present_flag` equal to 0 specifies that `vui_num_units_in_tick`, `vui_time_scale`, `vui_poc_proportional_to_timing_flag`, and `vui_hrd_parameters_present_flag` are not present in the `vui_parameters()` syntax structure.

vui_num_units_in_tick is the number of time units of a clock operating at the frequency `vui_time_scale` Hz that corresponds to one increment (called a clock tick) of a clock tick counter. `vui_num_units_in_tick` shall be greater than 0. A clock tick, in units of seconds, is equal to the quotient of `vui_num_units_in_tick` divided by `vui_time_scale`. For example, when the picture rate of a video signal is 25 Hz, `vui_time_scale` may be equal to 27 000 000 and `vui_num_units_in_tick` may be equal to 1 080 000, and consequently a clock tick may be equal to 0.04 seconds.

When `vps_num_units_in_tick` is present in the VPS referred to by the SPS, `vui_num_units_in_tick`, when present, shall be equal to `vps_num_units_in_tick`, and when not present, is inferred to be equal to `vps_num_units_in_tick`.

vui_time_scale is the number of time units that pass in one second. For example, a time coordinate system that measures time using a 27 MHz clock has a `vui_time_scale` of 27 000 000. The value of `vui_time_scale` shall be greater than 0.

When `vps_time_scale` is present in the VPS referred to by the SPS, `vui_time_scale`, when present, shall be equal to `vps_time_scale`, and when not present, is inferred to be equal to `vps_time_scale`.

vui_poc_proportional_to_timing_flag equal to 1 indicates that the picture order count value for each picture in the CVS that is not the first picture in the CVS, in decoding order, is proportional to the output time of the picture relative to the output time of the first picture in the CVS. `vui_poc_proportional_to_timing_flag` equal to 0 indicates that the picture order count value for each picture in the CVS that is not the first picture in the CVS, in decoding order, may or may not be proportional to the output time of the picture relative to the output time of the first picture in the CVS.

When `vps_poc_proportional_to_timing_flag` is present in the VPS referred to by the SPS and the value is equal to 1, `vui_poc_proportional_to_timing_flag`, when present, shall be equal to 1.

vui_num_ticks_poc_diff_one_minus1 plus 1 specifies the number of clock ticks corresponding to a difference of picture order count values equal to 1. The value of `vui_num_ticks_poc_diff_one_minus1` shall be in the range of 0 to $2^{32} - 2$, inclusive.

When `vps_num_ticks_poc_diff_one_minus1` is present in the VPS referred to by the SPS, `vui_num_ticks_poc_diff_one_minus1`, when present, shall be equal to `vps_num_ticks_poc_diff_one_minus1`.

vui_hrd_parameters_present_flag equal to 1 specifies that the syntax structure `hrd_parameters()` is present in the `vui_parameters()` syntax structure. `vui_hrd_parameters_present_flag` equal to 0 specifies that the syntax structure `hrd_parameters()` is not present in the `vui_parameters()` syntax structure.

bitstream_restriction_flag equal to 1, specifies that the bitstream restriction parameters for the CVS are present. `bitstream_restriction_flag` equal to 0, specifies that the bitstream restriction parameters for the CVS are not present.

tiles_fixed_structure_flag equal to 1 indicates that each PPS that is active in the CVS has the same value of the syntax elements `num_tile_columns_minus1`, `num_tile_rows_minus1`, `uniform_spacing_flag`, `column_width_minus1[i]`, `row_height_minus1[i]` and `loop_filter_across_tiles_enabled_flag`, when present. `tiles_fixed_structure_flag` equal to 0 indicates that tiles syntax elements in different PPSs may or may not have the same value. When the `tiles_fixed_structure_flag` syntax element is not present, it is inferred to be equal to 0.

NOTE 17 The signalling of `tiles_fixed_structure_flag` equal to 1 is a guarantee to a decoder that each picture in the CVS has the same number of tiles distributed in the same way which might be useful for workload allocation in the case of multi-threaded decoding.

motion_vectors_over_pic_boundaries_flag equal to 0 indicates that no sample outside the picture boundaries and no sample at a fractional sample position for which the sample value is derived using one or more samples outside the picture boundaries is used for inter prediction of any sample. **motion_vectors_over_pic_boundaries_flag** equal to 1 indicates that one or more samples outside the picture boundaries may be used in inter prediction. When the **motion_vectors_over_pic_boundaries_flag** syntax element is not present, **motion_vectors_over_pic_boundaries_flag** value is inferred to be equal to 1.

restricted_ref_pic_lists_flag equal to 1 indicates that all P and B slices (when present) that belong to the same picture have an identical reference picture list 0, and that all B slices (when present) that belong to the same picture have an identical reference picture list 1.

min_spatial_segmentation_idc, when not equal to 0, establishes a bound on the maximum possible size of distinct coded spatial segmentation regions in the pictures of the CVS. When **min_spatial_segmentation_idc** is not present, it is inferred to be equal to 0. The value of **min_spatial_segmentation_idc** shall be in the range of 0 to 4 095, inclusive.

The variable **minSpatialSegmentationTimes4** is derived from **min_spatial_segmentation_idc** as follows:

$$\text{minSpatialSegmentationTimes4} = \text{min_spatial_segmentation_idc} + 4 \quad (\text{E-66})$$

A slice is said to contain a specific luma sample when the coding block that contains the luma sample is contained in the slice. Correspondingly, a tile is said to contain a specific luma sample when the coding block that contains the luma sample is contained in the tile.

Depending on the value of **min_spatial_segmentation_idc**, the following apply:

- If **min_spatial_segmentation_idc** is equal to 0, no limit on the maximum size of spatial segments is indicated.
- Otherwise (**min_spatial_segmentation_idc** is not equal to 0), it is a requirement of bitstream conformance that exactly one of the following conditions shall be true:
 - In each PPS that is activated within the CVS, **tiles_enabled_flag** is equal to 0 and **entropy_coding_sync_enabled_flag** is equal to 0, and there is no slice in the CVS that contains more than $(4 * \text{PicSizeInSamplesY}) / \text{minSpatialSegmentationTimes4}$ luma samples.
 - In each PPS that is activated within the CVS, **tiles_enabled_flag** is equal to 1 and **entropy_coding_sync_enabled_flag** is equal to 0, and there is no tile in the CVS that contains more than $(4 * \text{PicSizeInSamplesY}) / \text{minSpatialSegmentationTimes4}$ luma samples.
 - In each PPS that is activated within the CVS, **tiles_enabled_flag** is equal to 0 and **entropy_coding_sync_enabled_flag** is equal to 1, and the syntax elements **pic_width_in_luma_samples**, **pic_height_in_luma_samples** and the variable **CtbSizeY** obey the following constraint:

$$(2 * \text{pic_height_in_luma_samples} + \text{pic_width_in_luma_samples}) * \text{CtbSizeY} \leq (4 * \text{PicSizeInSamplesY}) / \text{minSpatialSegmentationTimes4} \quad (\text{E-67})$$

NOTE 18 The syntax element **min_spatial_segmentation_idc** can be used by a decoder to calculate the maximum number of luma samples to be processed by one processing thread, making the assumption that the decoder maximally utilizes the parallel decoding information. However, it is important to be aware that there may be some inter-dependencies between the different threads, e.g. due to entropy coding synchronization or deblocking filtering across tile or slice boundaries. To aid decoders in planning the decoding workload distribution, encoders are encouraged to set the value of **min_spatial_segmentation_idc** to the highest possible value for which one of the above three conditions is true. For example, for the case when **tiles_enabled_flag** is equal to 0 and **entropy_coding_sync_enabled_flag** is equal to 1, encoders should set **min_spatial_segmentation_idc** equal to

$$4 * \text{PicSizeInSamplesY} / ((2 * \text{pic_height_in_luma_samples} + \text{pic_width_in_luma_samples}) * \text{CtbSizeY}) - 4.$$

ISO/IEC 23008-2:2017(E)

max_bytes_per_pic_denom indicates a number of bytes not exceeded by the sum of the sizes of the VCL NAL units associated with any coded picture in the CVS.

The number of bytes that represent a picture in the NAL unit stream is specified for this purpose as the total number of bytes of VCL NAL unit data (i.e. the total of the NumBytesInNalUnit variables for the VCL NAL units) for the picture. The value of max_bytes_per_pic_denom shall be in the range of 0 to 16, inclusive.

Depending on the value of max_bytes_per_pic_denom the following apply:

- If max_bytes_per_pic_denom is equal to 0, no limits are indicated.
- Otherwise (max_bytes_per_pic_denom is not equal to 0), it is a requirement of bitstream conformance that no coded picture shall be represented in the CVS by more than the following number of bytes.

$$(\text{PicSizeInMinCbsY} * \text{RawMinCuBits}) \div (8 * \text{max_bytes_per_pic_denom}) \quad (\text{E-68})$$

When the max_bytes_per_pic_denom syntax element is not present, the value of max_bytes_per_pic_denom is inferred to be equal to 2.

max_bits_per_min_cu_denom indicates an upper bound for the number of coded bits of coding_unit() data for any coding block in any picture of the CVS. The value of max_bits_per_min_cu_denom shall be in the range of 0 to 16, inclusive.

Depending on the value of max_bits_per_min_cu_denom, the following apply:

- If max_bits_per_min_cu_denom is equal to 0, no limit is specified by this syntax element.
- Otherwise (max_bits_per_min_cu_denom is not equal to 0), it is a requirement of bitstream conformance that no coded coding_unit() shall be represented in the bitstream by more than the following number of bits:

$$(\text{128} + \text{RawMinCuBits}) \div \text{max_bits_per_min_cu_denom} * (1 \ll (2 * (\text{log2CbSize} - \text{MinCbLog2SizeY}))) \quad (\text{E-69})$$

where log2CbSize is the value of log2CbSize for the given coding block and the number of bits of coding_unit() data for the same coding block is given by the number of times read_bits(1) is called in 9.3.4.3.3 and 9.3.4.3.4.

When the max_bits_per_min_cu_denom is not present, the value of max_bits_per_min_cu_denom is inferred to be equal to 1.

log2_max_mv_length_horizontal and **log2_max_mv_length_vertical** indicate the maximum absolute value of a decoded horizontal and vertical motion vector component, respectively, in quarter luma sample units, for all pictures in the CVS. A value of n asserts that no value of a motion vector component is outside the range of -2^n to $2^n - 1$, inclusive, in units of quarter luma sample displacement. The value of log2_max_mv_length_horizontal shall be in the range of 0 to 16, inclusive. The value of log2_max_mv_length_vertical shall be in the range of 0 to 15, inclusive. When log2_max_mv_length_horizontal is not present, the values of log2_max_mv_length_horizontal and log2_max_mv_length_vertical is inferred to be equal to 15.

E.3.2 HRD parameters semantics

The hrd_parameters() syntax structure provides HRD parameters used in the HRD operations for a layer set. When the hrd_parameters() syntax structure is included in a VPS, the applicable layer set to which the hrd_parameters() syntax structure applies is specified by the corresponding hrd_layer_set_idx[i] syntax element in the VPS. When the hrd_parameters() syntax structure is included in an SPS, the layer set to which the hrd_parameters() syntax structure applies is the layer set for which the associated layer identifier list contains all nuh_layer_id values present in the CVS.

For interpretation of the following semantics, the bitstream (or a part thereof) refers to the bitstream subset (or a part thereof) associated with the layer set to which the `hrd_parameters()` syntax structure applies.

`nal_hrd_parameters_present_flag` equal to 1 specifies that NAL HRD parameters (pertaining to Type II bitstream conformance) are present in the `hrd_parameters()` syntax structure. `nal_hrd_parameters_present_flag` equal to 0 specifies that NAL HRD parameters are not present in the `hrd_parameters()` syntax structure.

NOTE 1 When `nal_hrd_parameters_present_flag` is equal to 0, the conformance of the bitstream cannot be verified without provision of the NAL HRD parameters and all buffering period and picture timing SEI messages, by some means not specified in this document.

The variable `NalHrdBpPresentFlag` is derived as follows:

- If one or more of the following conditions are true, the value of `NalHrdBpPresentFlag` is set equal to 1:
 - `nal_hrd_parameters_present_flag` is present in the bitstream and is equal to 1.
 - The need for presence of buffering periods for NAL HRD operation to be present in the bitstream in buffering period SEI messages is determined by the application, by some means not specified in this document.
- Otherwise, the value of `NalHrdBpPresentFlag` is set equal to 0.

`vcl_hrd_parameters_present_flag` equal to 1 specifies that VCL HRD parameters (pertaining to all bitstream conformance) are present in the `hrd_parameters()` syntax structure. `vcl_hrd_parameters_present_flag` equal to 0 specifies that VCL HRD parameters are not present in the `hrd_parameters()` syntax structure.

NOTE 2 When `vcl_hrd_parameters_present_flag` is equal to 0, the conformance of the bitstream cannot be verified without provision of the VCL HRD parameters and all buffering period and picture timing SEI messages, by some means not specified in this document.

The variable `VclHrdBpPresentFlag` is derived as follows:

- If one or more of the following conditions are true, the value of `VclHrdBpPresentFlag` is set equal to 1:
 - `vcl_hrd_parameters_present_flag` is present in the bitstream and is equal to 1.
 - The need for presence of buffering periods for VCL HRD operation to be present in the bitstream in buffering period SEI messages is determined by the application, by some means not specified in this document.
- Otherwise, the value of `VclHrdBpPresentFlag` is set equal to 0.

The variable `CpbDpbDelaysPresentFlag` is derived as follows:

- If one or more of the following conditions are true, the value of `CpbDpbDelaysPresentFlag` is set equal to 1:
 - `nal_hrd_parameters_present_flag` is present in the bitstream and is equal to 1.
 - `vcl_hrd_parameters_present_flag` is present in the bitstream and is equal to 1.
 - The need for presence of CPB and DPB output delays to be present in the bitstream in picture timing SEI messages is determined by the application, by some means not specified in this document.

— Otherwise, the value of CpbDpbDelaysPresentFlag is set equal to 0.

When NalHrdBpPresentFlag and VclHrdBpPresentFlag are both equal to 0, the value of CpbDpbDelaysPresentFlag shall be equal to 0.

sub_pic_hrd_params_present_flag equal to 1 specifies that sub-picture level HRD parameters are present and the HRD may operate at access unit level or sub-picture level. **sub_pic_hrd_params_present_flag** equal to 0 specifies that sub-picture level HRD parameters are not present and the HRD operates at access unit level. When **sub_pic_hrd_params_present_flag** is not present, its value is inferred to be equal to 0.

tick_divisor_minus2 is used to specify the clock sub-tick. A clock sub-tick is the minimum interval of time that can be represented in the coded data when **sub_pic_hrd_params_present_flag** is equal to 1.

du_cpb_removal_delay_increment_length_minus1 plus 1 specifies the length, in bits, of the **du_cpb_removal_delay_increment_minus1[i]** and **du_common_cpb_removal_delay_increment_minus1** syntax elements of the picture timing SEI message and the **du_spt_cpb_removal_delay_increment** syntax element in the decoding unit information SEI message.

sub_pic_cpb_params_in_pic_timing_sei_flag equal to 1 specifies that sub-picture level CPB removal delay parameters are present in picture timing SEI messages and no decoding unit information SEI message is available (in the CVS or provided through external means not specified in this document). **sub_pic_cpb_params_in_pic_timing_sei_flag** equal to 0 specifies that sub-picture level CPB removal delay parameters are present in decoding unit information SEI messages and picture timing SEI messages do not include sub-picture level CPB removal delay parameters. When the **sub_pic_cpb_params_in_pic_timing_sei_flag** syntax element is not present, it is inferred to be equal to 0.

dpb_output_delay_du_length_minus1 plus 1 specifies the length, in bits, of the **pic_dpb_output_du_delay** syntax element in the picture timing SEI message and the **pic_spt_dpb_output_du_delay** syntax element in the decoding unit information SEI message.

bit_rate_scale (together with **bit_rate_value_minus1[i]**) specifies the maximum input bit rate of the *i*-th CPB.

cpb_size_scale (together with **cpb_size_value_minus1[i]**) specifies the CPB size of the *i*-th CPB when the CPB operates at the access unit level.

cpb_size_du_scale (together with **cpb_size_du_value_minus1[i]**) specifies the CPB size of the *i*-th CPB when the CPB operates at sub-picture level.

initial_cpb_removal_delay_length_minus1 plus 1 specifies the length, in bits, of the **nal_initial_cpb_removal_delay[i]**, **nal_initial_cpb_removal_offset[i]**, **vcl_initial_cpb_removal_delay[i]**, and **vcl_initial_cpb_removal_offset[i]** syntax elements of the buffering period SEI message. When the **initial_cpb_removal_delay_length_minus1** syntax element is not present, it is inferred to be equal to 23.

au_cpb_removal_delay_length_minus1 plus 1 specifies the length, in bits, of the **cpb_delay_offset** syntax element in the buffering period SEI message and the **au_cpb_removal_delay_minus1** syntax element in the picture timing SEI message. When the **au_cpb_removal_delay_length_minus1** syntax element is not present, it is inferred to be equal to 23.

dpb_output_delay_length_minus1 plus 1 specifies the length, in bits, of the **dpb_delay_offset** syntax element in the buffering period SEI message and the **pic_dpb_output_delay** syntax element in the picture timing SEI message. When the **dpb_output_delay_length_minus1** syntax element is not present, it is inferred to be equal to 23.

fixed_pic_rate_general_flag[i] equal to 1 indicates that, when HighestTid is equal to *i*, the temporal distance between the HRD output times of consecutive pictures in output order is constrained as specified below. **fixed_pic_rate_general_flag[i]** equal to 0 indicates that this constraint may not apply.

When **fixed_pic_rate_general_flag[i]** is not present, it is inferred to be equal to 0.

fixed_pic_rate_within_cvs_flag[*i*] equal to 1 indicates that, when HighestTid is equal to *i*, the temporal distance between the HRD output times of consecutive pictures in output order is constrained as specified below. **fixed_pic_rate_within_cvs_flag**[*i*] equal to 0 indicates that this constraint may not apply.

When **fixed_pic_rate_general_flag**[*i*] is equal to 1, the value of **fixed_pic_rate_within_cvs_flag**[*i*] is inferred to be equal to 1.

elemental_duration_in_tc_minus1[*i*] plus 1 (when present) specifies, when HighestTid is equal to *i*, the temporal distance, in clock ticks, between the elemental units that specify the HRD output times of consecutive pictures in output order as specified below. The value of **elemental_duration_in_tc_minus1**[*i*] shall be in the range of 0 to 2 047, inclusive.

For each picture *n* that is output and not the last picture in the bitstream (in output order) that is output, the value of the variable **DpbOutputElementalInterval**[*n*] is specified by:

$$\text{DpbOutputElementalInterval}[n] = \text{DpbOutputInterval}[n] \div \text{DeltaToDivisor} \quad (\text{E-70})$$

where **DpbOutputInterval**[*n*] is specified in Formulan (C-16) and **DeltaToDivisor** is specified in Table E.6 based on the value of **frame_field_info_present_flag** and **pic_struct** for the CVS containing picture *n*. Entries marked “-” in Table E.6 indicate a lack of dependence of **DeltaToDivisor** on the corresponding syntax element.

When HighestTid is equal to *i* and **fixed_pic_rate_general_flag**[*i*] is equal to 1 for a CVS containing picture *n*, the value computed for **DpbOutputElementalInterval**[*n*] shall be equal to $\text{ClockTick} * (\text{elemental_duration_in_tc_minus1}[i] + 1)$, wherein **ClockTick** is as specified in Formula (C-1) (using the value of **ClockTick** for the CVS containing picture *n*) when one of the following conditions is true for the following picture in output order **nextPicInOutputOrder** that is specified for use in Formula (C-16):

- picture **nextPicInOutputOrder** is in the same CVS as picture *n*.
- picture **nextPicInOutputOrder** is in a different CVS and **fixed_pic_rate_general_flag**[*i*] is equal to 1 in the CVS containing picture **nextPicInOutputOrder**, the value of **ClockTick** is the same for both CVSs, and the value of **elemental_duration_in_tc_minus1**[*i*] is the same for both CVSs.

When HighestTid is equal to *i* and **fixed_pic_rate_within_cvs_flag**[*i*] is equal to 1 for a CVS containing picture *n*, the value computed for **DpbOutputElementalInterval**[*n*] shall be equal to $\text{ClockTick} * (\text{elemental_duration_in_tc_minus1}[i] + 1)$, wherein **ClockTick** is as specified in Formula (C-1) (using the value of **ClockTick** for the CVS containing picture *n*) when the following picture in output order **nextPicInOutputOrder** that is specified for use in Formula (C-16) is in the same CVS as picture *n*.

Table E.6 — Divisor for computation of DpbOutputElementalInterval[n]

frame_field_info_present_flag	pic_struct	DeltaToDivisor
0	-	1
1	1	1
1	2	1
1	0	1
1	3	2
1	4	2
1	5	3
1	6	3
1	7	2
1	8	3
1	9	1
1	10	1
1	11	1
1	12	1

low_delay_hrd_flag[i] specifies the HRD operational mode, when HighestTid is equal to i, as specified in Annex C or F.13. When not present, the value of low_delay_hrd_flag[i] is inferred to be equal to 0.

NOTE 3 When low_delay_hrd_flag[i] is equal to 1, "big pictures" that violate the nominal CPB removal times due to the number of bits used by an access unit are permitted. It is expected, but not required, that such "big pictures" occur only occasionally.

cpb_cnt_minus1[i] plus 1 specifies the number of alternative CPB specifications in the bitstream of the CVS when HighestTid is equal to i. The value of cpb_cnt_minus1[i] shall be in the range of 0 to 31, inclusive. When not present, the value of cpb_cnt_minus1[i] is inferred to be equal to 0.

E.3.3 Sub-layer HRD parameters semantics

The variable CpbCnt is set equal to cpb_cnt_minus1[subLayerId].

bit_rate_value_minus1[i] (together with bit_rate_scale) specifies the maximum input bit rate for the i-th CPB when the CPB operates at the access unit level. bit_rate_value_minus1[i] shall be in the range of 0 to $2^{32} - 2$, inclusive. For any $i > 0$, bit_rate_value_minus1[i] shall be greater than bit_rate_value_minus1[i - 1].

When SubPicHrdFlag is equal to 0, the bit rate in bits per second is given by:

$$\text{BitRate}[i] = (\text{bit_rate_value_minus1}[i] + 1) * 2^{(6 + \text{bit_rate_scale})} \tag{E-71}$$

When SubPicHrdFlag is equal to 0 and the bit_rate_value_minus1[i] syntax element is not present, the value of BitRate[i] is inferred to be equal to BrVclFactor * MaxBR for VCL HRD parameters and to be equal to BrNalFactor * MaxBR for NAL HRD parameters, where MaxBR, BrVclFactor and BrNalFactor are specified in A.4.

cpb_size_value_minus1[i] is used together with cpb_size_scale to specify the i-th CPB size when the CPB operates at the access unit level. cpb_size_value_minus1[i] shall be in the range of 0 to $2^{32} - 2$, inclusive. For any i greater than 0, cpb_size_value_minus1[i] shall be less than or equal to cpb_size_value_minus1[i - 1].

When SubPicHrdFlag is equal to 0, the CPB size in bits is given by:

$$\text{CpbSize}[i] = (\text{cpb_size_value_minus1}[i] + 1) * 2^{(4 + \text{cpb_size_scale})} \quad (\text{E-72})$$

When SubPicHrdFlag is equal to 0 and the `cpb_size_value_minus1[i]` syntax element is not present, the value of `CpbSize[i]` is inferred to be equal to `CpbVclFactor * MaxCPB` for VCL HRD parameters and to be equal to `CpbNalFactor * MaxCPB` for NAL HRD parameters, where `MaxCPB`, `CpbVclFactor` and `CpbNalFactor` are specified in A.4.

`cpb_size_du_value_minus1[i]` is used together with `cpb_size_du_scale` to specify the *i*-th CPB size when the CPB operates at sub-picture level. `cpb_size_du_value_minus1[i]` shall be in the range of 0 to $2^{32} - 2$, inclusive. For any *i* greater than 0, `cpb_size_du_value_minus1[i]` shall be less than or equal to `cpb_size_du_value_minus1[i - 1]`.

When SubPicHrdFlag is equal to 1, the CPB size in bits is given by:

$$\text{CpbSize}[i] = (\text{cpb_size_du_value_minus1}[i] + 1) * 2^{(4 + \text{cpb_size_du_scale})} \quad (\text{E-73})$$

When SubPicHrdFlag is equal to 1 and the `cpb_size_du_value_minus1[i]` syntax element is not present, the value of `CpbSize[i]` is inferred to be equal to `CpbVclFactor * MaxCPB` for VCL HRD parameters and to be equal to `CpbNalFactor * MaxCPB` for NAL HRD parameters, where `MaxCPB`, `CpbVclFactor` and `CpbNalFactor` are specified in A.4.

`bit_rate_du_value_minus1[i]` (together with `bit_rate_scale`) specifies the maximum input bit rate for the *i*-th CPB when the CPB operates at the sub-picture level. `bit_rate_du_value_minus1[i]` shall be in the range of 0 to $2^{32} - 2$, inclusive. For any *i* > 0, `bit_rate_du_value_minus1[i]` shall be greater than `bit_rate_du_value_minus1[i - 1]`.

When SubPicHrdFlag is equal to 1, the bit rate in bits per second is given by:

$$\text{BitRate}[i] = (\text{bit_rate_du_value_minus1}[i] + 1) * 2^{(6 + \text{bit_rate_scale})} \quad (\text{E-74})$$

When SubPicHrdFlag is equal to 1 and the `bit_rate_du_value_minus1[i]` syntax element is not present, the value of `BitRate[i]` is inferred to be equal to `BrVclFactor * MaxBR` for VCL HRD parameters and to be equal to `BrNalFactor * MaxBR` for NAL HRD parameters, where `MaxBR`, `BrVclFactor` and `BrNalFactor` are specified in A.4.

`cbr_flag[i]` equal to 0 specifies that to decode this CVS by the HRD using the *i*-th CPB specification, the hypothetical stream scheduler (HSS) operates in an intermittent bit rate mode. `cbr_flag[i]` equal to 1 specifies that the HSS operates in a constant bit rate (CBR) mode. When not present, the value of `cbr_flag[i]` is inferred to be equal to 0.

Annex F (normative)

Common specifications for multi-layer extensions

F.1 General

This annex specifies the common syntax, semantics, and decoding processes for multi-layer video coding extensions, with references made to Clauses 2 to 9 and Annexes A to E, G, and H.

F.2 References

The list of normative references in Clause 2 applies.

F.3 Definitions

For the purpose of this annex, the following definitions apply in addition to the definitions in Clause 3. These definitions are either not present in Clause 3 or replace definitions in Clause 3.

F.3.1 access unit: A set of *NAL units* that are associated with each other according to a specified classification rule, are consecutive in *decoding order*, and contain at most one *coded picture* with any specific value of *nuh_layer_id*.

F.3.2 additional layer set: A set of *layers* of a *bitstream* with a set of *layers* of one or more *non-base layer subtrees*.

F.3.3 alternative output layer: A *layer* that is a *reference layer* of an *output layer* and which may include a *picture* that may be output when no *picture* of the *output layer* is present in the *access unit* containing the *picture*.

F.3.4 associated IRAP picture: The previous *IRAP picture* in *decoding order* within the same *layer* (if present).

F.3.5 auxiliary picture: A *picture* that has no normative effect on the *decoding process* of *primary pictures*, and with a *nuh_layer_id* value such that $\text{AuxId}[\text{nuh_layer_id}]$ is greater than 0.

F.3.6 auxiliary picture layer: A *layer* with a *nuh_layer_id* value such that $\text{AuxId}[\text{nuh_layer_id}]$ is greater than 0.

F.3.7 base bitstream partition: A *bitstream partition* that contains the layer with *nuh_layer_id* equal to *SmallestLayerId*.

F.3.8 bitstream partition: A sequence of bits, in the form of a *NAL unit stream* or a *byte stream*, that is a subset of a *bitstream* according to a *partitioning scheme*.

F.3.9 broken link access (BLA) access unit: An *access unit* in which the *coded picture* with *nuh_layer_id* equal to *SmallestLayerId* is a *BLA picture*.

F.3.10 clean random access (CRA) access unit: An *access unit* in which the *coded picture* with *nuh_layer_id* equal to *SmallestLayerId* is a *CRA picture*.

F.3.11 coded layer-wise video sequence (CLVS): A sequence of *coded pictures*, with the same *nuh_layer_id* value *nuhLayerId*, that consists, in *decoding order*, of an *IRAP picture* with *NoRaslOutputFlag* equal to 1 or a *picture* with $\text{FirstPicInLayerDecodedFlag}[\text{nuhLayerId}]$ equal to 0, followed by all *coded pictures*, if any, up to but excluding the next *IRAP picture* with *NoRaslOutputFlag* equal to 1 or the next *picture* with $\text{FirstPicInLayerDecodedFlag}[\text{nuhLayerId}]$ equal to 0.

- F.3.12** coded picture: A *coded representation* of a *picture* comprising *VCL NAL units* with a particular value of *nuh_layer_id* within an *access unit* and containing all *coding tree units* of the *picture*.
- F.3.13** coded picture buffer (CPB): A first-in first-out buffer containing *decoding units* in *decoding order* specified in the *hypothetical reference decoder* in Annex C or in F.13.
- F.3.14** coded video sequence (CVS): A sequence of *access units* that consists, in decoding order, of an *initial IRAP access unit*, followed by zero or more *access units* that are not *initial IRAP access units*, including all subsequent *access units* up to but not including any subsequent *access unit* that is an *initial IRAP access unit*.
- F.3.15** collocated sample: A reference picture sample located at a corresponding position to the current sample as determined through the resampling process, for use in *inter-layer prediction*.
- F.3.16** cross-layer random access skip (CL-RAS) picture: A *picture* with *nuh_layer_id* equal to *layerId* such that *LayerInitializedFlag[layerId]* is equal to 0 when the decoding process for starting the decoding of a coded picture with *nuh_layer_id* greater than 0 is invoked.
- F.3.17** decoded picture buffer (DPB): A buffer holding *decoded pictures* for reference, output reordering, or output delay specified for the *hypothetical reference decoder* in Annex C or in F.13.
- F.3.18** decoding unit: A *partition unit* if *SubPicHrdFlag* is equal to 0 or a subset of a *partition unit* otherwise, consisting of one or more *VCL NAL units* in a *partition unit* and the associated *non-VCL NAL units*.
- F.3.19** direct predicted layer: A *layer* for which another *layer* is a *direct reference layer*.
- F.3.20** direct reference layer: A *layer* that may be used for *inter-layer prediction* of another *layer*.
- F.3.21** direct reference layer picture: A *picture* in a *direct reference layer* that is used as input to derive an *inter-layer reference picture* for *inter-layer prediction* of the current *picture* and is in the same *access unit* as the current *picture*.
- F.3.22** independent layer: A *layer* that does not have *direct reference layers*.
- F.3.23** indirect predicted layer: A *layer* for which another *layer* is an *indirect reference layer*.
- F.3.24** indirect reference layer: A *layer* that is not a *direct reference layer* of a second *layer* but is a *direct reference layer* of a third *layer* that is a *reference layer* of the second *layer*.
- F.3.25** initial intra random access point (IRAP) access unit: An *IRAP access unit* in which the *coded picture* with *nuh_layer_id* equal to *SmallestLayerId* has *NoRaslOutputFlag* equal to 1.
- F.3.26** inter-layer prediction: A *prediction* in a manner that is dependent on data elements (e.g. sample values or motion vectors) of *reference pictures* with a different value of *nuh_layer_id* than that of the current *picture*.
- F.3.27** inter-layer reference picture: A *reference picture* that may be used for *inter-layer prediction* of the current *picture* and is in the same *access unit* as the current *picture*.
- F.3.28** intra random access point (IRAP) access unit: An *access unit* in which the *coded picture* with *nuh_layer_id* equal to *SmallestLayerId* is an *IRAP picture*.
- F.3.29** intra random access point (IRAP) picture: A *coded picture* for which each *VCL NAL unit* has *nal_unit_type* in the range of *BLA_W_LP* to *RSV_IRAP_VCL23*, inclusive.

NOTE An IRAP picture belonging to an independent layer contains only I slices. An IRAP picture belonging to a predicted layer with *nuh_layer_id* value *currLayerId* may contain P, B, and I slices, cannot use inter prediction from other pictures with *nuh_layer_id* equal to *currLayerId*, and may use inter-layer prediction from its direct reference layers. The IRAP picture belonging to a predicted layer with *nuh_layer_id* value *currLayerId* and all subsequent non-RASL pictures with *nuh_layer_id* equal to *currLayerId* in decoding order can be correctly decoded without performing the decoding process of any pictures with *nuh_layer_id* equal to *currLayerId* that precede the IRAP picture in decoding order, when the necessary parameter sets are available when they need to be activated and *LayerInitializedFlag[refLayerId]* is equal to 1 for *refLayerId* equal to all *nuh_layer_id* values of the direct reference layers of the layer with *nuh_layer_id* equal to *currLayerId*.

F.3.30 layer subtree: A subset of the *layers* of a *layer tree* including all the *reference layers* of the *layers* within the subset.

F.3.31 layer tree: A set of *layers* such that each *layer* in the set of *layers* is a *predicted layer* or a *reference layer* of at least one other *layer* in the set of *layers* and no *layer* outside the set of *layers* is a *predicted layer* or a *reference layer* of any *layer* in the set of *layers*.

F.3.32 leading picture: A *picture* that is in the same *layer* as the *associated IRAP picture* and precedes the *associated IRAP picture* in *output order*.

F.3.33 necessary layer: A *layer* in an *output operation point* associated with an *OLS*, the *layer* being an *output layer* of the *OLS*, or a *reference layer* of an *output layer* of the *OLS*.

F.3.34 non-base layer: A *layer* in which all *VCL NAL units* have the same *nuh_layer_id* value greater than 0.

F.3.35 non-base layer subtree: A *layer subtree* that does not include the *base layer*.

F.3.36 output layer: A *layer* of an *output layer set* that is output when *TargetOlsIdx* is equal to the index of the *output layer set*.

F.3.37 output layer set (OLS): A set of *layers* consisting of the *layers* of one of the specified *layer sets*, where one or more *layers* in the set of *layers* are indicated to be *output layers*.

F.3.38 output operation point: A *bitstream* that is created from an input *bitstream* by operation of the *sub-bitstream extraction process* with the input *bitstream*, a target highest *TemporalId*, and a target *layer identifier list* as inputs, and that is associated with a set of *output layers*.

F.3.39 output order: The order in which the *decoded pictures* are output from the *decoded picture buffer* (for the *decoded pictures* that are to be output from the *decoded picture buffer*), or the order in which the *access units* are considered to be output from the *decoded picture buffer* (for the *access units* the decoding of which results into *decoded pictures* that are to be output from the *decoded picture buffer*).

F.3.40 partitioning scheme: A *partitioning* of *layers* in an *OLS* into one or more *bitstream partitions* such that each *layer* in the *OLS* is included in exactly one *bitstream partition* of the partitioning scheme and each *bitstream partition* of the partitioning scheme contains one or more *layers*.

F.3.41 partition unit: A subset of *access unit* consisting of the *picture units* of the *layers* in a *bitstream partition*.

F.3.42 picture order count (POC): A variable that is associated with each *picture* and that, at any moment, uniquely identifies the associated *picture* among all *pictures* with the same value of *nuh_layer_id* in the *CVS*, and, when the associated *picture* is to be output from the *decoded picture buffer*, indicates the position of the associated *picture* in *output order* relative to the *output order* positions of the other *pictures* with the same value of *nuh_layer_id* in the same *CVS* that are to be output from the *decoded picture buffer*.

F.3.43 picture order count (POC) resetting period: A sequence of *access units* in *decoding order*, starting with an *access unit* with *poc_reset_idc* equal to 1 or 2 and a particular value of *poc_reset_period_id* and including all *access units* that either have the same value of *poc_reset_period_id* or have *poc_reset_idc* equal to 0.

F.3.44 picture order count (POC) resetting picture: A *picture* that is the first *picture*, in *decoding order*, of a *layer* of a *POC resetting period*.

F.3.45 predicted layer: A *layer* that is a *direct predicted layer* or an *indirect predicted layer* of another *layer*.

F.3.46 primary picture: A *picture* with *nuh_layer_id* value such that *AuxId[nuh_layer_id]* is equal to 0.

F.3.47 primary picture layer: A *layer* with a *nuh_layer_id* value such that *AuxId[nuh_layer_id]* is equal to 0.

F.3.48 quality scalability: A type of scalability, represented by a scalability dimension, that indicates that the *coded pictures* in all *layers* of a bitstream have the same values of *luma* width, *luma* height, *chroma* width, and *chroma* height, but may have different fidelity level or different values of *luma* or *chroma* bit depths.

F.3.49 reference layer: A *layer* that is a *direct reference layer* or an *indirect reference layer* of another *layer*.

F.3.50 reference picture list: A list of *reference pictures* that is used for *inter prediction* or *inter-layer prediction* of a *P* or *B slice*.

F.3.51 scalability dimension: An indication of the type of *non-base layers* which may be present in a *CVS*.

F.3.52 source picture for inter-layer prediction: A *decoded picture* that either is, or is used in deriving, an *inter-layer reference picture* that is included in an inter-layer reference picture set of the current *picture*.

F.3.53 spatial scalability: A type of scalability, represented by a scalability dimension, that indicates that the *coded pictures* in different *layers* of a *bitstream* have different values of *luma* or *chroma* width or height.

F.3.54 sub-bitstream extraction process: A specified process by which *NAL units* in a *bitstream* that do not belong to a target set, determined by a target highest TemporalId and a target *layer identifier list*, are removed from the *bitstream*, with the output sub-bitstream consisting of the *NAL units* in the *bitstream* that belong to the target set.

NOTE Depending on whether the target layer identifier list includes *nuh_layer_id* equal to 0 and on the value of *vps_base_layer_internal_flag*, the sub-bitstream extraction process may refer to the process specified in Clause 10, F.10.1, or F.10.3.

F.3.55 target output layer set: The *output layer set* for which the index is equal to *TargetOlsIdx*.

F.3.56 trailing picture: A *picture* that is in the same *layer* as the *associated IRAP picture* and follows the *associated IRAP picture* in *output order*.

F.3.57 view: A sequence of *pictures* associated with the same value of *ViewOrderIdx*.

NOTE A view typically represents a sequence of pictures captured by one camera.

F.4 Abbreviated terms

For the purpose of this annex, the following abbreviationed terms apply in addition to the abbreviated terms in Clause 4.

BPB	Bitstream Partition Buffer
HBPS	Hypothetical Bitstream Partition Scheduler
OLS	Output Layer Set

F.5 Conventions

The specifications in Clause 5 and its subclauses apply.

F.6 Bitstream and picture formats, partitionings, scanning processes, and neighbouring relationships

The specifications in Clause 6 and its subclauses apply.

F.7 Syntax and semantics

F.7.1 Method of specifying syntax in tabular form

The specifications in 7.1 apply.

F.7.2 Specification of syntax functions, categories, and descriptors

The specifications in 7.2 apply, with the following additions.

`more_data_in_slice_segment_header_extension()` is specified as follows:

- If (the current position in the `slice_segment_header()` syntax structure) – (the position immediately following `slice_segment_header_extension_length`) is less than (`slice_segment_header_extension_length * 8`), the return value of `more_data_in_slice_segment_header_extension()` is equal to TRUE.
- Otherwise, the return value of `more_data_in_slice_segment_header_extension()` is equal to FALSE.

F.7.3 Syntax in tabular form

F.7.3.1 NAL unit syntax

F.7.3.1.1 General NAL unit syntax

The specifications in 7.3.1.1 apply.

F.7.3.1.2 NAL unit header syntax

The specifications in 7.3.1.2 apply.

F.7.3.2 Raw byte sequence payloads and RBSP trailing bits syntax

F.7.3.2.1 Video parameter set RBSP

	Descriptor
<code>video_parameter_set_rbsp()</code> {	
vps_video_parameter_set_id	u(4)
vps_base_layer_internal_flag	u(1)
vps_base_layer_available_flag	u(1)
vps_max_layers_minus1	u(6)
vps_max_sub_layers_minus1	u(3)
vps_temporal_id_nesting_flag	u(1)
vps_reserved_0xffff_16bits	u(16)
profile_tier_level(1, vps_max_sub_layers_minus1)	
vps_sub_layer_ordering_info_present_flag	u(1)
for(i = (vps_sub_layer_ordering_info_present_flag ? 0 : vps_max_sub_layers_minus1); i <= vps_max_sub_layers_minus1; i++) {	

vps_max_dec_pic_buffering_minus1 [i]	ue(v)
vps_max_num_reorder_pics [i]	ue(v)
vps_max_latency_increase_plus1 [i]	ue(v)
}	
vps_max_layer_id	u(6)
vps_num_layer_sets_minus1	ue(v)
for(i = 1; i <= vps_num_layer_sets_minus1; i++)	
for(j = 0; j <= vps_max_layer_id; j++)	
layer_id_included_flag [i][j]	u(1)
vps_timing_info_present_flag	u(1)
if(vps_timing_info_present_flag) {	
vps_num_units_in_tick	u(32)
vps_time_scale	u(32)
vps_poc_proportional_to_timing_flag	u(1)
if(vps_poc_proportional_to_timing_flag)	
vps_num_ticks_poc_diff_one_minus1	ue(v)
vps_num_hrd_parameters	ue(v)
for(i = 0; i < vps_num_hrd_parameters; i++) {	
hrd_layer_set_idx [i]	ue(v)
if(i > 0)	
cprms_present_flag [i]	u(1)
hrd_parameters(cprms_present_flag[i], vps_max_sub_layers_minus1)	
}	
}	
}	
vps_extension_flag	u(1)
if(vps_extension_flag) {	
while(!byte_aligned())	
vps_extension_alignment_bit_equal_to_one	u(1)
vps_extension()	
vps_extension2_flag	u(1)
if(vps_extension2_flag)	
while(more_rbsp_data())	
vps_extension_data_flag	u(1)
}	
rbsp_trailing_bits()	
}	

F.7.3.2.1.1 Video parameter set extension syntax

	Descriptor
vps_extension() {	
if(vps_max_layers_minus1 > 0 && vps_base_layer_internal_flag)	
profile_tier_level(0, vps_max_sub_layers_minus1)	
splitting_flag	u(1)
for(i = 0, NumScalabilityTypes = 0; i < 16; i++) {	
scalability_mask_flag[i]	u(1)
NumScalabilityTypes += scalability_mask_flag[i]	
}	
for(j = 0; j < (NumScalabilityTypes - splitting_flag); j++)	
dimension_id_len_minus1[j]	u(3)
vps_nuh_layer_id_present_flag	u(1)
for(i = 1; i <= MaxLayersMinus1; i++) {	
if(vps_nuh_layer_id_present_flag)	
layer_id_in_nuh[i]	u(6)
if(!splitting_flag)	
for(j = 0; j < NumScalabilityTypes; j++)	
dimension_id[i][j]	u(v)
}	
view_id_len	u(4)
if(view_id_len > 0)	
for(i = 0; i < NumViews; i++)	
view_id_val[i]	u(v)
for(i = 1; i <= MaxLayersMinus1; i++)	
for(j = 0; j < i; j++)	
direct_dependency_flag[i][j]	u(1)
if(NumIndependentLayers > 1)	
num_add_layer_sets	ue(v)
for(i = 0; i < num_add_layer_sets; i++)	
for(j = 1; j < NumIndependentLayers; j++)	
highest_layer_idx_plus1[i][j]	u(v)
vps_sub_layers_max_minus1_present_flag	u(1)
if(vps_sub_layers_max_minus1_present_flag)	
for(i = 0; i <= MaxLayersMinus1; i++)	
sub_layers_vps_max_minus1[i]	u(3)
max_tid_ref_present_flag	u(1)
if(max_tid_ref_present_flag)	
for(i = 0; i < MaxLayersMinus1; i++)	

for(j = i + 1; j <= MaxLayersMinus1; j++)	
if(direct_dependency_flag[j][i])	
max_tid_il_ref_pics_plus1 [i][j]	u(3)
default_ref_layers_active_flag	u(1)
vps_num_profile_tier_level_minus1	ue(v)
for(i = vps_base_layer_internal_flag ? 2 : 1; i <= vps_num_profile_tier_level_minus1; i++) {	
vps_profile_present_flag [i]	u(1)
profile_tier_level(vps_profile_present_flag[i], vps_max_sub_layers_minus1)	
}	
if(NumLayerSets > 1) {	
num_add_olss	ue(v)
default_output_layer_idc	u(2)
}	
NumOutputLayerSets = num_add_olss + NumLayerSets	
for(i = 1; i < NumOutputLayerSets; i++) {	
if(NumLayerSets > 2 && i >= NumLayerSets)	
layer_set_idx_for_ols_minus1 [i]	u(v)
if(i > vps_num_layer_sets_minus1 defaultOutputLayerIdc == 2)	
for(j = 0; j < NumLayersInIdList[OlsIdxToLsIdx[i]]; j++)	
output_layer_flag [i][j]	u(1)
for(j = 0; j < NumLayersInIdList[OlsIdxToLsIdx[i]]; j++)	
if(NecessaryLayerFlag[i][j] && vps_num_profile_tier_level_minus1 > 0)	
profile_tier_level_idx [i][j]	u(v)
if(NumOutputLayersInOutputLayerSet[i] == 1 && NumDirectRefLayers[OlsHighestOutputLayerId[i]] > 0)	
alt_output_layer_flag [i]	u(1)
}	
vps_num_rep_formats_minus1	ue(v)
for(i = 0; i <= vps_num_rep_formats_minus1; i++)	
rep_format()	
if(vps_num_rep_formats_minus1 > 0)	
rep_format_idx_present_flag	u(1)
if(rep_format_idx_present_flag)	
for(i = vps_base_layer_internal_flag ? 1 : 0; i <= MaxLayersMinus1; i++)	
vps_rep_format_idx [i]	u(v)
max_one_active_ref_layer_flag	u(1)
vps_poc_lsb_aligned_flag	u(1)
for(i = 1; i <= MaxLayersMinus1; i++)	

if(NumDirectRefLayers[layer_id_in_nuh[i]] == 0)	
poc_lsb_not_present_flag[i]	u(1)
dpb_size()	
direct_dep_type_len_minus2	ue(v)
direct_dependency_all_layers_flag	u(1)
if(direct_dependency_all_layers_flag)	
direct_dependency_all_layers_type	u(v)
else {	
for(i = vps_base_layer_internal_flag ? 1 : 2; i <= MaxLayersMinus1; i++)	
for(j = vps_base_layer_internal_flag ? 0 : 1; j < i; j++)	
if(direct_dependency_flag[i][j])	
direct_dependency_type[i][j]	u(v)
}	
vps_non_vui_extension_length	ue(v)
for(i = 1; i <= vps_non_vui_extension_length; i++)	
vps_non_vui_extension_data_byte	u(8)
vps_vui_present_flag	u(1)
if(vps_vui_present_flag) {	
while(!byte_aligned())	
vps_vui_alignment_bit_equal_to_one	u(1)
vps_vui()	
}	
}	

F.7.3.2.1.2 Representation format syntax

	Descriptor
rep_format() {	
pic_width_vps_in_luma_samples	u(16)
pic_height_vps_in_luma_samples	u(16)
chroma_and_bit_depth_vps_present_flag	u(1)
if(chroma_and_bit_depth_vps_present_flag) {	
chroma_format_vps_idc	u(2)
if(chroma_format_vps_idc == 3)	
separate_colour_plane_vps_flag	u(1)
bit_depth_vps_luma_minus8	u(4)
bit_depth_vps_chroma_minus8	u(4)
}	
conformance_window_vps_flag	u(1)
if(conformance_window_vps_flag) {	
conf_win_vps_left_offset	ue(v)

conf_win_vps_right_offset	ue(v)
conf_win_vps_top_offset	ue(v)
conf_win_vps_bottom_offset	ue(v)
}	
}	

F.7.3.2.1.3 DPB size syntax

dpb_size() {	
for(i = 1; i < NumOutputLayerSets; i++) {	
currLsIdx = OlsIdxToLsIdx[i]	
sub_layer_flag_info_present_flag[i]	u(1)
for(j = 0; j <= MaxSubLayersInLayerSetMinus1[currLsIdx]; j++) {	
if(j > 0 && sub_layer_flag_info_present_flag[i])	
sub_layer_dpb_info_present_flag[i][j]	u(1)
if(sub_layer_dpb_info_present_flag[i][j]) {	
for(k = 0; k < NumLayersInIdList[currLsIdx]; k++)	
if(NecessaryLayerFlag[i][k] && (vps_base_layer_internal_flag (LayerSetLayerIdList[currLsIdx][k] != 0)))	
max_vps_dec_pic_buffering_minus1[i][k][j]	ue(v)
max_vps_num_reorder_pics[i][j]	ue(v)
max_vps_latency_increase_plus1[i][j]	ue(v)
}	
}	
}	
}	
}	

F.7.3.2.1.4 VPS VUI syntax

vps_vui() {	Descriptor
cross_layer_pic_type_aligned_flag	u(1)
if(!cross_layer_pic_type_aligned_flag)	
cross_layer_irap_aligned_flag	u(1)
if(cross_layer_irap_aligned_flag)	
all_layers_idr_aligned_flag	u(1)
bit_rate_present_vps_flag	u(1)
pic_rate_present_vps_flag	u(1)
if(bit_rate_present_vps_flag pic_rate_present_vps_flag)	
for(i = vps_base_layer_internal_flag ? 0 : 1; i < NumLayerSets; i++)	
for(j = 0; j <= MaxSubLayersInLayerSetMinus1[i]; j++) {	
if(bit_rate_present_vps_flag)	
bit_rate_present_flag[i][j]	u(1)

if(pic_rate_present_vps_flag)	
pic_rate_present_flag[i][j]	u(1)
if(bit_rate_present_flag[i][j]) {	
avg_bit_rate[i][j]	u(16)
max_bit_rate[i][j]	u(16)
}	
if(pic_rate_present_flag[i][j]) {	
constant_pic_rate_idc[i][j]	u(2)
avg_pic_rate[i][j]	u(16)
}	
}	
video_signal_info_idx_present_flag	u(1)
if(video_signal_info_idx_present_flag)	
vps_num_video_signal_info_minus1	u(4)
for(i = 0; i <= vps_num_video_signal_info_minus1; i++)	
video_signal_info()	
if(video_signal_info_idx_present_flag && vps_num_video_signal_info_minus1 > 0)	
for(i = vps_base_layer_internal_flag ? 0 : 1; i <= MaxLayersMinus1; i++)	
vps_video_signal_info_idx[i]	u(4)
tiles_not_in_use_flag	u(1)
if(!tiles_not_in_use_flag) {	
for(i = vps_base_layer_internal_flag ? 0 : 1; i <= MaxLayersMinus1; i++) {	
tiles_in_use_flag[i]	u(1)
if(tiles_in_use_flag[i])	
loop_filter_not_across_tiles_flag[i]	u(1)
}	
for(i = vps_base_layer_internal_flag ? 1 : 2; i <= MaxLayersMinus1; i++)	
for(j = 0; j < NumDirectRefLayers[layer_id_in_nuh[i]]; j++) {	
layerIdx = LayerIdxInVps[IdDirectRefLayer[layer_id_in_nuh[i]][j]]	
if(tiles_in_use_flag[i] && tiles_in_use_flag[layerIdx])	
tile_boundaries_aligned_flag[i][j]	u(1)
}	
}	
wpp_not_in_use_flag	u(1)
if(!wpp_not_in_use_flag)	
for(i = vps_base_layer_internal_flag ? 0 : 1; i <= MaxLayersMinus1; i++)	
wpp_in_use_flag[i]	u(1)
single_layer_for_non_irap_flag	u(1)
higher_layer_irap_skip_flag	u(1)

ilp_restricted_ref_layers_flag	u(1)
if(ilp_restricted_ref_layers_flag)	
for(i = 1; i <= MaxLayersMinus1; i++)	
for(j = 0; j < NumDirectRefLayers[layer_id_in_nuh[i]]; j++)	
if(vps_base_layer_internal_flag IdDirectRefLayer[layer_id_in_nuh[i]][j] > 0) {	
min_spatial_segment_offset_plus1[i][j]	ue(v)
if(min_spatial_segment_offset_plus1[i][j] > 0) {	
ctu_based_offset_enabled_flag[i][j]	u(1)
if(ctu_based_offset_enabled_flag[i][j])	
min_horizontal_ctu_offset_plus1[i][j]	ue(v)
}	
}	
}	
vps_vui_bsp_hrd_present_flag	u(1)
if(vps_vui_bsp_hrd_present_flag)	
vps_vui_bsp_hrd_params()	
for(i = 1; i <= MaxLayersMinus1; i++)	
if(NumDirectRefLayers[layer_id_in_nuh[i]] = 0)	
base_layer_parameter_set_compatibility_flag[i]	u(1)
}	

F.7.3.2.1.5 Video signal info syntax

video_signal_info() {	Descriptor
video_vps_format	u(3)
video_full_range_vps_flag	u(1)
colour_primaries_vps	u(8)
transfer_characteristics_vps	u(8)
matrix_coeffs_vps	u(8)
}	

F.7.3.2.1.6 VPS VUI bitstream partition HRD parameters syntax

vps_vui_bsp_hrd_params() {	Descriptor
vps_num_add_hrd_params	ue(v)
for(i = vps_num_hrd_parameters; i < vps_num_hrd_parameters + vps_num_add_hrd_params; i++) {	
if(i > 0)	
cprms_add_present_flag[i]	u(1)
num_sub_layer_hrd_minus1[i]	ue(v)
hrd_parameters(cprms_add_present_flag[i], num_sub_layer_hrd_minus1[i])	
}	
if(vps_num_hrd_parameters + vps_num_add_hrd_params > 0)	

for(h = 1; h < NumOutputLayerSets; h++) {	
num_signalled_partitioning_schemes [h]	ue(v)
for(j = 1; j < num_signalled_partitioning_schemes[h] + 1; j++) {	
num_partitions_in_scheme_minus1 [h][j]	ue(v)
for(k = 0; k <= num_partitions_in_scheme_minus1[h][j]; k++)	
for(r = 0; r < NumLayersInIdList[OlsIdxToLsIdx[h]]; r++)	
layer_included_in_partition_flag [h][j][k][r]	u(1)
}	
for(i = 0; i < num_signalled_partitioning_schemes[h] + 1; i++)	
for(t = 0; t <= MaxSubLayersInLayerSetMinus1[OlsIdxToLsIdx[h]]; t++) {	
num_bsp_schedules_minus1 [h][i][t]	ue(v)
for(j = 0; j <= num_bsp_schedules_minus1[h][i][t]; j++)	
for(k = 0; k <= num_partitions_in_scheme_minus1[h][i]; k++) {	
if(vps_num_hrd_parameters + vps_num_add_hrd_params > 1)	
bsp_hrd_idx [h][i][t][j][k]	u(v)
bsp_sched_idx [h][i][t][j][k]	ue(v)
}	
}	
}	
}	
}	
}	

F.7.3.2.2 Sequence parameter set RBSP syntax

F.7.3.2.2.1 General sequence parameter set RBSP syntax

	Descriptor
seq_parameter_set_rbsp() {	
sps_video_parameter_set_id	u(4)
if(nuh_layer_id == 0)	
sps_max_sub_layers_minus1	u(3)
else	
sps_ext_or_max_sub_layers_minus1	u(3)
MultiLayerExtSpsFlag = (nuh_layer_id != 0 && sps_ext_or_max_sub_layers_minus1 == 7)	
if(!MultiLayerExtSpsFlag) {	
sps_temporal_id_nesting_flag	u(1)
profile_tier_level(1, sps_max_sub_layers_minus1)	
}	
sps_seq_parameter_set_id	ue(v)
if(MultiLayerExtSpsFlag) {	
update_rep_format_flag	u(1)
if(update_rep_format_flag)	

sps_rep_format_idx	u(8)
} else {	
chroma_format_idc	ue(v)
if(chroma_format_idc == 3)	
separate_colour_plane_flag	u(1)
pic_width_in_luma_samples	ue(v)
pic_height_in_luma_samples	ue(v)
conformance_window_flag	u(1)
if(conformance_window_flag) {	
conf_win_left_offset	ue(v)
conf_win_right_offset	ue(v)
conf_win_top_offset	ue(v)
conf_win_bottom_offset	ue(v)
}	
bit_depth_luma_minus8	ue(v)
bit_depth_chroma_minus8	ue(v)
}	
log2_max_pic_order_cnt_lsb_minus4	ue(v)
if(!MultiLayerExtSpsFlag) {	
sps_sub_layer_ordering_info_present_flag	u(1)
for(i = (sps_sub_layer_ordering_info_present_flag ? 0 : sps_max_sub_layers_minus1); i <= sps_max_sub_layers_minus1; i++) {	
sps_max_dec_pic_buffering_minus1[i]	ue(v)
sps_max_num_reorder_pics[i]	ue(v)
sps_max_latency_increase_plus1[i]	ue(v)
}	
}	
log2_min_luma_coding_block_size_minus3	ue(v)
log2_diff_max_min_luma_coding_block_size	ue(v)
log2_min_luma_transform_block_size_minus2	ue(v)
log2_diff_max_min_luma_transform_block_size	ue(v)
max_transform_hierarchy_depth_inter	ue(v)
max_transform_hierarchy_depth_intra	ue(v)
scaling_list_enabled_flag	u(1)
if(scaling_list_enabled_flag) {	
if(MultiLayerExtSpsFlag)	
sps_infer_scaling_list_flag	u(1)
if(sps_infer_scaling_list_flag)	
sps_scaling_list_ref_layer_id	u(6)

else {	
sps_scaling_list_data_present_flag	u(1)
if(sps_scaling_list_data_present_flag)	
scaling_list_data()	
}	
}	
amp_enabled_flag	u(1)
sample_adaptive_offset_enabled_flag	u(1)
pcm_enabled_flag	u(1)
if(pcm_enabled_flag) {	
pcm_sample_bit_depth_luma_minus1	u(4)
pcm_sample_bit_depth_chroma_minus1	u(4)
log2_min_pcm_luma_coding_block_size_minus3	ue(v)
log2_diff_max_min_pcm_luma_coding_block_size	ue(v)
pcm_loop_filter_disabled_flag	u(1)
}	
num_short_term_ref_pic_sets	ue(v)
for(i = 0; i < num_short_term_ref_pic_sets; i++)	
st_ref_pic_set(i)	
long_term_ref_pics_present_flag	u(1)
if(long_term_ref_pics_present_flag) {	
num_long_term_ref_pics_sps	ue(v)
for(i = 0; i < num_long_term_ref_pics_sps; i++) {	
lt_ref_pic_poc_lsb_sps[i]	u(v)
used_by_curr_pic_lt_sps_flag[i]	u(1)
}	
}	
sps_temporal_mvp_enabled_flag	u(1)
strong_intra_smoothing_enabled_flag	u(1)
vui_parameters_present_flag	u(1)
if(vui_parameters_present_flag)	
vui_parameters()	
sps_extension_present_flag	u(1)
if(sps_extension_present_flag) {	
sps_range_extension_flag	u(1)
sps_multilayer_extension_flag	u(1)
sps_3d_extension_flag	u(1)
sps_scc_extension_flag	u(1)
sps_extension_4bits	u(4)

}	
if(sps_range_extension_flag)	
sps_range_extension()	
if(sps_multilayer_extension_flag)	
sps_multilayer_extension()	
if(sps_3d_extension_flag)	
sps_3d_extension() /* specified in Annex I */	
if(sps_scc_extension_flag)	
sps_scc_extension()	
if(sps_extension_4bits)	
while(more_rbsp_data())	
sps_extension_data_flag	u(1)
rbsp_trailing_bits()	
}	

F.7.3.2.2.2 Sequence parameter set range extension syntax

The specifications in 7.3.2.2.2 apply.

F.7.3.2.2.3 Sequence parameter set screen content coding extension syntax

The specifications in 7.3.2.2.3 apply.

F.7.3.2.2.4 Sequence parameter set multilayer extension syntax

sps_multilayer_extension() {	Descriptor
inter_view_mv_vert_constraint_flag	u(1)
}	

F.7.3.2.3 Picture parameter set RBSP syntax**F.7.3.2.3.1 General picture parameter set RBSP syntax**

The specifications in 7.3.2.3.1 apply.

F.7.3.2.3.2 Picture parameter set range extension syntax

The specifications in 7.3.2.3.2 apply.

F.7.3.2.3.3 Picture parameter set screen content coding extension syntax

The specifications in 7.3.2.3.3 apply.

F.7.3.2.3.4 Picture parameter set multilayer extension syntax

	Descriptor
pps_multilayer_extension() {	
poc_reset_info_present_flag	u(1)
pps_infer_scaling_list_flag	u(1)
if(pps_infer_scaling_list_flag)	
pps_scaling_list_ref_layer_id	u(6)
num_ref_loc_offsets	ue(v)
for(i = 0; i < num_ref_loc_offsets; i++) {	
ref_loc_offset_layer_id[i]	u(6)
scaled_ref_layer_offset_present_flag[i]	u(1)
if(scaled_ref_layer_offset_present_flag[i]) {	
scaled_ref_layer_left_offset[ref_loc_offset_layer_id[i]]	se(v)
scaled_ref_layer_top_offset[ref_loc_offset_layer_id[i]]	se(v)
scaled_ref_layer_right_offset[ref_loc_offset_layer_id[i]]	se(v)
scaled_ref_layer_bottom_offset[ref_loc_offset_layer_id[i]]	se(v)
}	
ref_region_offset_present_flag[i]	u(1)
if(ref_region_offset_present_flag[i]) {	
ref_region_left_offset[ref_loc_offset_layer_id[i]]	se(v)
ref_region_top_offset[ref_loc_offset_layer_id[i]]	se(v)
ref_region_right_offset[ref_loc_offset_layer_id[i]]	se(v)
ref_region_bottom_offset[ref_loc_offset_layer_id[i]]	se(v)
}	
resample_phase_set_present_flag[i]	u(1)
if(resample_phase_set_present_flag[i]) {	
phase_hor_luma[ref_loc_offset_layer_id[i]]	ue(v)
phase_ver_luma[ref_loc_offset_layer_id[i]]	ue(v)
phase_hor_chroma_plus8[ref_loc_offset_layer_id[i]]	ue(v)
phase_ver_chroma_plus8[ref_loc_offset_layer_id[i]]	ue(v)
}	
}	
colour_mapping_enabled_flag	u(1)
if(colour_mapping_enabled_flag)	
colour_mapping_table()	
}	

F.7.3.2.3.5 General colour mapping table syntax

	Descriptor
colour_mapping_table() {	
num_cm_ref_layers_minus1	ue(v)
for(i = 0; i <= num_cm_ref_layers_minus1; i++)	
cm_ref_layer_id[i]	u(6)
cm_octant_depth	u(2)
cm_y_part_num_log2	u(2)
luma_bit_depth_cm_input_minus8	ue(v)
chroma_bit_depth_cm_input_minus8	ue(v)
luma_bit_depth_cm_output_minus8	ue(v)
chroma_bit_depth_cm_output_minus8	ue(v)
cm_res_quant_bits	u(2)
cm_delta_flc_bits_minus1	u(2)
if(cm_octant_depth == 1) {	
cm_adapt_threshold_u_delta	se(v)
cm_adapt_threshold_v_delta	se(v)
}	
colour_mapping_octants(0, 0, 0, 0, 1 << cm_octant_depth)	
}	

F.7.3.2.3.6 Colour mapping octants syntax

	Descriptor
colour_mapping_octants(inpDepth, idxY, idxCb, idxCr, inpLength) {	
if(inpDepth < cm_octant_depth)	
split_octant_flag	u(1)
if(split_octant_flag)	
for(k = 0; k < 2; k++)	
for(m = 0; m < 2; m++)	
for(n = 0; n < 2; n++)	
colour_mapping_octants(inpDepth + 1, idxY + PartNumY * k * inpLength / 2, idxCb + m * inpLength / 2, idxCr + n * inpLength / 2, inpLength / 2)	
else	
for(i = 0; i < PartNumY; i++) {	
idxShiftY = idxY + ((i << (cm_octant_depth - inpDepth))	
for(j = 0; j < 4; j++) {	
coded_res_flag[idxShiftY][idxCb][idxCr][j]	u(1)
if(coded_res_flag[idxShiftY][idxCb][idxCr][j])	
for(c = 0; c < 3; c++) {	
res_coeff_q[idxShiftY][idxCb][idxCr][j][c]	ue(v)
res_coeff_r[idxShiftY][idxCb][idxCr][j][c]	u(v)

<pre> if(res_coeff_q[idxShiftY][idxCb][idxCr][j][c] res_coeff_r[idxShiftY][idxCb][idxCr][j][c]) </pre>	
<pre> res_coeff_s[idxShiftY][idxCb][idxCr][j][c] </pre>	u(1)
<pre> } </pre>	
<pre> } </pre>	
<pre> } </pre>	
<pre> } </pre>	

F.7.3.2.4 Supplemental enhancement information RBSP syntax

The specifications in 7.3.2.4 apply.

F.7.3.2.5 Access unit delimiter RBSP syntax

The specifications in 7.3.2.5 apply.

F.7.3.2.6 End of sequence RBSP syntax

The specifications in 7.3.2.6 apply.

F.7.3.2.7 End of bitstream RBSP syntax

The specifications in 7.3.2.7 apply.

F.7.3.2.8 Filler data RBSP syntax

The specifications in 7.3.2.8 apply.

F.7.3.2.9 Slice segment layer RBSP syntax

The specifications in 7.3.2.9 apply.

F.7.3.2.10 RBSP slice segment trailing bits syntax

The specifications in 7.3.2.10 apply.

F.7.3.2.11 RBSP trailing bits syntax

The specifications in 7.3.2.11 apply.

F.7.3.2.12 Byte alignment syntax

The specifications in 7.3.2.12 apply.

F.7.3.3 Profile, tier, and level syntax

The specifications in 7.3.3 apply.

F.7.3.4 Scaling list data syntax

The specifications in 7.3.4 apply.

F.7.3.5 Supplemental enhancement information message syntax

The specifications in 7.3.5 apply.

F.7.3.6 Slice segment header syntax

F.7.3.6.1 General slice segment header syntax

slice_segment_header() {	Descriptor
first_slice_segment_in_pic_flag	u(1)
if(nal_unit_type >= BLA_W_LP && nal_unit_type <= RSV_IRAP_VCL23)	
no_output_of_prior_pics_flag	u(1)
slice_pic_parameter_set_id	ue(v)
if(!first_slice_segment_in_pic_flag) {	
if(dependent_slice_segments_enabled_flag)	
dependent_slice_segment_flag	u(1)
slice_segment_address	u(v)
}	
if(!dependent_slice_segment_flag) {	
i = 0	
if(num_extra_slice_header_bits > i) {	
i++	
discardable_flag	u(1)
}	
if(num_extra_slice_header_bits > i) {	
i++	
cross_layer_bla_flag	u(1)
}	
for(; i < num_extra_slice_header_bits; i++)	
slice_reserved_flag[i]	u(1)
slice_type	ue(v)
if(output_flag_present_flag)	
pic_output_flag	u(1)
if(separate_colour_plane_flag == 1)	
colour_plane_id	u(2)
if((nuh_layer_id > 0 && !poc_lsb_not_present_flag[LayerIdxInVps[nuh_layer_id]] (nal_unit_type != IDR_W_RADL && nal_unit_type != IDR_N_LP)))	
slice_pic_order_cnt_lsb	u(v)
if(nal_unit_type != IDR_W_RADL && nal_unit_type != IDR_N_LP) {	
short_term_ref_pic_set_sps_flag	u(1)
if(!short_term_ref_pic_set_sps_flag)	
st_ref_pic_set(num_short_term_ref_pic_sets)	
else if(num_short_term_ref_pic_sets > 1)	
short_term_ref_pic_set_idx	u(v)

if(long_term_ref_pics_present_flag) {	
if(num_long_term_ref_pics_sps > 0)	
num_long_term_sps	ue(v)
num_long_term_pics	ue(v)
for(i = 0; i < num_long_term_sps + num_long_term_pics; i++) {	
if(i < num_long_term_sps) {	
if(num_long_term_ref_pics_sps > 1)	
lt_idx_sps[i]	u(v)
} else {	
poc_lsb_lt[i]	u(v)
used_by_curr_pic_lt_flag[i]	u(1)
}	
delta_poc_msb_present_flag[i]	u(1)
if(delta_poc_msb_present_flag[i])	
delta_poc_msb_cycle_lt[i]	ue(v)
}	
}	
if(sps_temporal_mvp_enabled_flag)	
slice_temporal_mvp_enabled_flag	u(1)
}	
if(nuh_layer_id > 0 && !default_ref_layers_active_flag && NumDirectRefLayers[nuh_layer_id] > 0) {	
inter_layer_pred_enabled_flag	u(1)
if(inter_layer_pred_enabled_flag && NumDirectRefLayers[nuh_layer_id] > 1) {	
if(!max_one_active_ref_layer_flag)	
num_inter_layer_ref_pics_minus1	u(v)
if(NumActiveRefLayerPics != NumDirectRefLayers[nuh_layer_id])	
for(i = 0; i < NumActiveRefLayerPics; i++)	
inter_layer_pred_layer_idc[i]	u(v)
}	
}	
if(sample_adaptive_offset_enabled_flag) {	
slice_sao_luma_flag	u(1)
if(ChromaArrayType != 0)	
slice_sao_chroma_flag	u(1)
}	
if(slice_type == P slice_type == B) {	
num_ref_idx_active_override_flag	u(1)
if(num_ref_idx_active_override_flag) {	

num_ref_idx_l0_active_minus1	ue(v)
if(slice_type == B)	
num_ref_idx_l1_active_minus1	ue(v)
}	
if(lists_modification_present_flag && NumPicTotalCurr > 1)	
ref_pic_lists_modification()	
if(slice_type == B)	
mvd_l1_zero_flag	u(1)
if(cabac_init_present_flag)	
cabac_init_flag	u(1)
if(slice_temporal_mvp_enabled_flag) {	
if(slice_type == B)	
collocated_from_l0_flag	u(1)
if((collocated_from_l0_flag && num_ref_idx_l0_active_minus1 > 0) (!collocated_from_l0_flag && num_ref_idx_l1_active_minus1 > 0))	
collocated_ref_idx	ue(v)
}	
if((weighted_pred_flag && slice_type == P) (weighted_bipred_flag && slice_type == B))	
pred_weight_table()	
five_minus_max_num_merge_cand	ue(v)
}	
slice_qp_delta	se(v)
if(pps_slice_chroma_qp_offsets_present_flag) {	
slice_cb_qp_offset	se(v)
slice_cr_qp_offset	se(v)
}	
if(chroma_qp_offset_list_enabled_flag)	
cu_chroma_qp_offset_enabled_flag	u(1)
if(deblocking_filter_override_enabled_flag)	
deblocking_filter_override_flag	u(1)
if(deblocking_filter_override_flag) {	
slice_deblocking_filter_disabled_flag	u(1)
if(!slice_deblocking_filter_disabled_flag) {	
slice_beta_offset_div2	se(v)
slice_tc_offset_div2	se(v)
}	
}	
if(pps_loop_filter_across_slices_enabled_flag && (slice_sao_luma_flag slice_sao_chroma_flag	

!slice_deblocking_filter_disabled_flag))	
slice_loop_filter_across_slices_enabled_flag	u(1)
}	
if(tiles_enabled_flag entropy_coding_sync_enabled_flag) {	
num_entry_point_offsets	ue(v)
if(num_entry_point_offsets > 0) {	
offset_len_minus1	ue(v)
for(i = 0; i < num_entry_point_offsets; i++)	
entry_point_offset_minus1[i]	u(v)
}	
}	
if(slice_segment_header_extension_present_flag) {	
slice_segment_header_extension_length	ue(v)
if(poc_reset_info_present_flag)	
poc_reset_idc	u(2)
if(poc_reset_idc != 0)	
poc_reset_period_id	u(6)
if(poc_reset_idc == 3) {	
full_poc_reset_flag	u(1)
poc_lsb_val	u(v)
}	
if(!PocMsbValRequiredFlag && vps_poc_lsb_aligned_flag)	
poc_msb_cycle_val_present_flag	u(1)
if(poc_msb_cycle_val_present_flag)	
poc_msb_cycle_val	ue(v)
while(more_data_in_slice_segment_header_extension())	
slice_segment_header_extension_data_bit	u(1)
}	
byte_alignment()	
}	

F.7.3.6.2 Reference picture list modification syntax

The specifications in 7.3.6.2 apply.

F.7.3.6.3 Weighted prediction parameters syntax

The specifications in 7.3.6.3 apply.

F.7.3.7 Short-term reference picture set syntax

The specifications in 7.3.7 apply.

F.7.3.8 Slice segment data syntax**F.7.3.8.1 General slice segment data syntax**

The specifications in 7.3.8.1 apply.

F.7.3.8.2 Coding tree unit syntax

The specifications in 7.3.8.2 apply.

F.7.3.8.3 Sample adaptive offset syntax

The specifications in 7.3.8.3 apply.

F.7.3.8.4 Coding quadtree syntax

The specifications in 7.3.8.4 apply.

F.7.3.8.5 Coding unit syntax

The specifications in 7.3.8.5 apply.

F.7.3.8.6 Prediction unit syntax

The specifications in 7.3.8.6 apply.

F.7.3.8.7 PCM sample syntax

The specifications in 7.3.8.7 apply.

F.7.3.8.8 Transform tree syntax

The specifications in 7.3.8.8 apply.

F.7.3.8.9 Motion vector difference syntax

The specifications in 7.3.8.9 apply.

F.7.3.8.10 Transform unit syntax

The specifications in 7.3.8.10 apply.

F.7.3.8.11 Residual coding syntax

The specifications in 7.3.8.11 apply.

F.7.3.8.12 Cross-component prediction syntax

The specifications in 7.3.8.12 apply.

F.7.3.8.13 Palette mode syntax

The specifications in 7.3.8.13 apply.

F.7.3.8.14 Delta QP syntax

The specifications in 7.3.8.14 apply.

F.7.3.8.15 Chroma QP offset syntax

The specifications in 7.3.8.15 apply.

F.7.4 Semantics

F.7.4.1 General

NOTE The information in 7.4.1 applies.

F.7.4.2 NAL unit semantics

F.7.4.2.1 General NAL unit semantics

The specifications in 7.4.2.1 apply.

F.7.4.2.2 NAL unit header semantics

The specifications in 7.4.2.2 apply with the replacement of references to Annex C with references to F.13 and with the following additions:

The variable CraOrBlaPicFlag is derived as follows:

$$\text{CraOrBlaPicFlag} = (\text{nal_unit_type} = = \text{BLA_W_LP} \mid \mid \text{nal_unit_type} = = \text{BLA_N_LP} \mid \mid \text{nal_unit_type} = = \text{BLA_W_RADL} \mid \mid \text{nal_unit_type} = = \text{CRA_NUT}) \quad (\text{F-1})$$

NOTE 1 When a picture picA that is a CRA picture and belongs to a layer with nuh_layer_id equal to layerId is present in a bitstream and pictures belonging to the layer with nuh_layer_id equal to layerId and preceding, in decoding order, the picture picA are dropped due to layer down-switching followed by layer up-switching, the RASL pictures associated with the picture picA, if any, may have some reference pictures that may not be available for reference unless one of the following conditions is true:

- The access unit auA containing the picture picA is an IRAP access unit, and the picture with nuh_layer_id equal to SmallestLayerId in the access unit auA, if any, has NoClrasOutputFlag equal to 1.
- The value of HandleCraAsBlaFlag is equal to 1 for the CRA picture picA.

A NAL unit with nal_unit_type equal to EOS_NUT and with a particular nuh_layer_id value shall not be present in an access unit, unless a coded picture with that particular nuh_layer_id value is present in the same access unit.

NOTE 2 Let indepLayerId be nuh_layer_id value of any independent non-base layer with nuh_layer_id greater than SmallestLayerId. Let firstPic be the first picture, in decoding order, among the pictures with nuh_layer_id equal to indepLayerId or IdPredictedLayer[indepLayerId][i] for any value of i in the range of 0 to NumPredictedLayers[indepLayerId] - 1, inclusive, that follows an IRAP picture with NoClrasOutputFlag equal to 1. firstPic has to be an IRAP picture with nuh_layer_id equal to indepLayerId and with LayerResetFlag equal to 1.

When nal_unit_type is equal to AUD_NUT, the value of nuh_layer_id shall be equal to the minimum of the nuh_layer_id values of all VCL NAL units in the access unit.

F.7.4.2.3 Encapsulation of an SODB within an RBSP (informative)

The specifications in 7.4.2.3 apply.

F.7.4.2.4 Order of NAL units and association to coded pictures, access units, and coded video sequences

F.7.4.2.4.1 General

The specifications in 7.4.2.4.1 apply.

F.7.4.2.4.2 Order of VPS, SPS and PPS RBSPs and their activation

The specifications in 7.4.2.4.2 apply with the following additions.

A PPS RBSP includes parameters that can be referred to by the coded slice segment NAL units of one or more coded pictures. Each PPS RBSP is initially considered not active for any layer at the start of the operation of the decoding process. At most one PPS RBSP is considered active for each layer at any given moment during the operation of the decoding process, and the activation of any particular PPS RBSP for a particular layer results in the deactivation of the previously-active PPS RBSP for the particular layer (if any).

One PPS RBSP may be the active PPS RBSP for more than one layer. When not explicitly specified, the layer a PPS RBSP is active for is inferred to be the current layer in the context where the active PPS RBSP is referred to.

When a PPS RBSP (with a particular value of `pps_pic_parameter_set_id`) is not active for a particular layer with `nuh_layer_id` `activatingLayerId` and it is referred to by a coded slice segment NAL unit (using a value of `slice_pic_parameter_set_id` equal to the `pps_pic_parameter_set_id` value) of the particular layer, it is activated for the particular layer. This PPS RBSP is called the active PPS RBSP for the particular layer until it is deactivated by the activation of another PPS RBSP for the particular layer. A PPS RBSP, with that particular value of `pps_pic_parameter_set_id`, shall be available to the decoding process prior to its activation, included in at least one access unit with `TemporalId` less than or equal to the `TemporalId` of the PPS NAL unit or provided through external means, and the PPS NAL unit containing the PPS RBSP shall have `nuh_layer_id` equal to 0, `activatingLayerId`, or `IdRefLayer[activatingLayerId][i]` with any value of `i` in the range of 0 to `NumRefLayers[activatingLayerId] - 1`, inclusive.

NOTE 1 All PPSs, regardless of their values of `nuh_layer_id` or `TemporalId`, share the same value space for `pps_pic_parameter_set_id`. In other words, a PPS with `nuh_layer_id` equal to X, `TemporalId` equal to Y, and `pps_pic_parameter_set_id` equal to A would update the previously received PPS that has `pps_pic_parameter_set_id` equal to A and that has `nuh_layer_id` not equal to X or `TemporalId` not equal to Y.

An SPS RBSP includes parameters that can be referred to by one or more PPS RBSPs or one or more SEI NAL units containing an active parameter sets SEI message. Each SPS RBSP is initially considered not active for any layer at the start of the operation of the decoding process. At most, one SPS RBSP is considered active for each layer at any given moment during the operation of the decoding process, and the activation of any particular SPS RBSP for a particular layer results in the deactivation of the previously-active SPS RBSP for that particular layer (if any).

One SPS RBSP may be the active SPS RBSP for more than one layer. When not explicitly specified, the layer an SPS RBSP is active for is inferred to be the current layer in the context where the active SPS RBSP is referred to.

When an SPS RBSP (with a particular value of `sps_seq_parameter_set_id`) is not already active for a particular non-base layer with `nuh_layer_id` `nuhLayerId` and it is referred to by activation of a PPS RBSP (in which `pps_seq_parameter_set_id` is equal to the `sps_seq_parameter_set_id` value), or is referred to by an SEI NAL unit containing an active parameter sets SEI message (in which `active_seq_parameter_set_id[layer_sps_idx[LayerIdxInVps[nuhLayerId]]]` is equal to the `sps_seq_parameter_set_id` value), it is activated for the particular non-base layer. This SPS RBSP is called the active SPS RBSP for the particular non-base layer until it is deactivated by the activation of another SPS RBSP for the particular non-base layer. An SPS RBSP, with the particular value of

sps_seq_parameter_set_id, shall be available to the decoding process prior to its activation, included in at least one access unit with TemporalId equal to 0 or provided through external means, and the SPS NAL unit containing the SPS RBSP shall have nuh_layer_id equal to 0, nuhLayerId, or IdRefLayer[nuhLayerId][i] with any value of i in the range of 0 to NumRefLayers[nuhLayerId] - 1, inclusive. An activated SPS RBSP for a particular layer shall remain active for the entire CLVS of that particular layer.

The contents of the hrd_parameters() syntax structure shall remain unchanged within a sequence of activated SPS RBSPs, in their activation order, from any activated SPS RBSP until the end of the bitstream or up to but excluding an SPS RBSP that is activated within the next access unit in which at least one of the following conditions is true:

- The access unit includes a picture for each nuh_layer_id value in TargetDecLayerIdList and each picture in the access unit is an IDR picture.
- The access unit includes an IRAP picture with nuh_layer_id equal to SmallestLayerId for which NoClrasOutputFlag is equal to 1.

Any SPS NAL unit with any nuh_layer_id value containing the value of sps_seq_parameter_set_id for the active SPS RBSP for a particular layer shall have the same content as that of the active SPS RBSP for the particular layer unless it follows the access unit auA containing the last coded picture for which the active SPS RBSP for the particular layer is required to be active for the particular layer and precedes the first NAL unit succeeding auA in decoding order that activates an SPS RBSP with the same value of seq_parameter_set_id.

NOTE 2 All SPSs, regardless of their values of nuh_layer_id, share the same value space for sps_seq_parameter_set_id. In other words, an SPS with nuh_layer_id equal to X and sps_seq_parameter_set_id equal to A would update the previously received SPS with nuh_layer_id not equal to X and sps_seq_parameter_set_id equal to A.

When a VPS RBSP (with a particular value of vps_video_parameter_set_id) is not already active and it is referred to by activation of an SPS RBSP (in which sps_video_parameter_set_id is equal to the vps_video_parameter_set_id value), or is referred to by an SEI NAL unit containing an active parameter sets SEI message (in which active_video_parameter_set_id is equal to the vps_video_parameter_set_id value), it is activated. This VPS RBSP is called the active VPS RBSP until it is deactivated by the activation of another VPS RBSP. A VPS RBSP, with that particular value of vps_video_parameter_set_id, shall be available to the decoding process prior to its activation, included in at least one access unit with TemporalId equal to 0 or provided through external means, and the VPS NAL unit containing the VPS RBSP shall have nuh_layer_id equal to 0 or SmallestLayerId.

An activated VPS RBSP shall remain active until the end of the bitstream or until it is deactivated by another VPS RBSP in an access unit in which at least one of the following conditions is true:

- The access unit includes a picture for each nuh_layer_id value in TargetDecLayerIdList and each picture in the access unit is an IDR picture.
- The access unit includes an IRAP picture with nuh_layer_id equal to SmallestLayerId for which NoClrasOutputFlag is equal to 1.

For any VPS NAL unit within the CVS with any value of nuh_layer_id and the value of vps_video_parameter_set_id equal to that of the active VPS RBSP for a CVS, the VPS RBSP in the VPS NAL unit shall have the same content as that of the active VPS RBSP for the CVS.

All constraints that are expressed on the relationship between the values of the syntax elements and the values of variables derived from those syntax elements in VPSs, SPSs, and PPSs and other syntax elements are expressions of constraints that apply only to the active VPS RBSP, the active SPS RBSP for any particular layer, and the active PPS RBSP for any particular layer. If any VPS RBSP, SPS RBSP, and PPS RBSP is present that is never activated in the bitstream, its syntax elements shall have values that

would conform to the specified constraints if it was activated by reference in an otherwise conforming bitstream.

During operation of the decoding process for NAL units of a non-base layer, the values of parameters of the active VPS RBSP, the active SPS RBSP for the non-base layer, and the active PPS RBSP for the non-base layer are considered in effect. For interpretation of SEI messages applicable to a coded picture of a non-base layer, the values of the active VPS RBSP, the active SPS RBSP for the non-base layer, and the active PPS RBSP for the non-base layer for the operation of the decoding process for the VCL NAL units of the coded picture are considered in effect unless otherwise specified in the SEI message semantics.

F.7.4.2.4.3 Order of access units association to CVSs

A bitstream conforming to this document consists of one or more CVSs.

A CVS consists of one or more access units. The order of NAL units and coded pictures and their association to access units is described in F.7.4.2.4.4.

The first access unit of a CVS is an IRAP access unit with NoRaslOutputFlag equal to 1.

It is a requirement of bitstream conformance that, when present, the next access unit after an access unit that contains an end of sequence NAL unit with nuh_layer_id equal to SmallestLayerId or an end of bitstream NAL unit shall be an IRAP access unit.

F.7.4.2.4.4 Order of NAL units and coded pictures and association to access units

This subclause specifies the order of NAL units and coded pictures and their association to access unit for CVSs that contain NAL units with nuh_layer_id greater than 0 that are decoded using the decoding processes specified in Annexes F, G, and H.

An access unit consists of one or more coded pictures, each with a distinct value of nuh_layer_id, and zero or more non-VCL NAL units. The association of VCL NAL units to coded pictures is described in 7.4.2.4.5. The first access unit in the bitstream starts with the first NAL unit of the bitstream.

A VCL NAL unit is the first VCL NAL unit of an access unit, when all of the following conditions are true:

- first_slice_segment_in_pic_flag is equal to 1.
- At least one of the following conditions is true:
 - The previous picture in decoding order belongs to a different POC resetting period than the picture containing the VCL NAL unit.
 - PicOrderCntVal derived for the VCL NAL unit differs from the PicOrderCntVal of the previous picture in decoding order.

NOTE 1 For any two consecutive access units auA and auB that belong to the same POC resetting period, the PicOrderCntVal of pictures in auA cannot be the same as the PicOrderCntVal of pictures in auB.

NOTE 2 Additionally, more conditions, e.g. the following conditions, could but does not need to be used:

- The nuh_layer_id value of the VCL NAL unit is equal to SmallestLayerId.
- vps_poc_lsb_aligned_flag is equal to 1 and the slice_pic_order_cnt_lsb value of the VCL NAL unit differs from the slice_pic_order_cnt_lsb value of the previous VCL NAL unit in decoding order.

ISO/IEC 23008-2:2017(E)

The first of any of the following NAL units preceding the first VCL NAL unit `firstVclNalUnitInAu` and succeeding the last VCL NAL unit preceding `firstVclNalUnitInAu`, if any, specifies the start of a new access unit:

- Access unit delimiter NAL unit (when present);
- VPS NAL unit (when present);
- SPS NAL unit (when present);
- PPS NAL unit (when present);
- Prefix SEI NAL unit (when present);
- NAL units with `nal_unit_type` in the range of `RSV_NVCL41..RSV_NVCL44` (when present);
- NAL units with `nal_unit_type` in the range of `UNSPEC48..UNSPEC55` (when present).

When there is none of the above NAL units preceding `firstVclNalUnitInAu` and succeeding the last VCL NAL unit preceding `firstVclNalUnitInAu`, if any, `firstVclNalUnitInAu` starts a new access unit.

A coded picture with `nuh_layer_id` equal to `nuhLayerIdA` shall precede, in decoding order, all coded pictures with `nuh_layer_id` greater than `nuhLayerIdA` in the same access unit.

The order of the coded pictures and non-VCL NAL units within an access unit shall obey the following constraints:

- When an access unit delimiter NAL unit is present, it shall be the first NAL unit. There shall be at most one access unit delimiter NAL unit in any access unit.
- When any VPS NAL units, SPS NAL units, PPS NAL units, prefix SEI NAL units, NAL units with `nal_unit_type` in the range of `RSV_NVCL41..RSV_NVCL44`, or NAL units with `nal_unit_type` in the range of `UNSPEC48..UNSPEC55` are present, they shall not follow the last VCL NAL unit of the access unit.
- NAL units having `nal_unit_type` equal to `FD_NUT` or `SUFFIX_SEI_NUT`, or in the range of `RSV_NVCL45..RSV_NVCL47` or `UNSPEC56..UNSPEC63` shall not precede the first VCL NAL unit of the access unit.
- When an end of sequence NAL unit with `nuh_layer_id` `nuhLayerId` is present, it shall be the last NAL unit with `nuh_layer_id` equal to `nuhLayerId` in the access unit other than an end of bitstream NAL unit (when present).
- When an end of bitstream NAL unit is present, it shall be the last NAL unit in the access unit.

F.7.4.2.4.5 Order of VCL NAL units and association to coded pictures

The specifications in 7.4.2.4.5 apply.

F.7.4.3 Raw byte sequence payloads, trailing bits, and byte alignment semantics

F.7.4.3.1 Video parameter set RBSP semantics

The specifications in 7.4.3.1 apply with the replacement of references to Annex C with references to F.13, with the replacement of the semantics of the syntax element `vps_extension_flag` with that specified below, and with the following additions.

Each output operation point is associated with an operation point, a list of `nuh_layer_id` values of the output layers, in increasing order of `nuh_layer_id` values, denoted as `OptLayerIdList`, and the `OpTid` of

the associated operation point. The OpLayerIdList of the operation point associated with an output operation point is also referred to as the OpLayerIdList of the output operation point.

vps_extension_flag equal to 0 specifies that no `vps_extension()` syntax structure is present in the VPS RBSP syntax structure. `vps_extension_flag` equal to 1 specifies that the `vps_extension()` syntax structure is present in the VPS RBSP syntax structure. When `MaxLayersMinus1` is greater than 0, `vps_extension_flag` shall be equal to 1.

vps_extension_alignment_bit_equal_to_one shall be equal to 1.

vps_extension2_flag equal to 0 specifies that no `vps_extension_data_flag` syntax elements are present in the VPS RBSP syntax structure. `vps_extension2_flag` equal to 1 specifies `vps_extension_data_flag` syntax elements are present in the VPS RBSP syntax structure. Decoders conforming to a profile specified in Annexes A, G, or H shall ignore all data that follow the value 1 for `vps_extension2_flag` in a VPS NAL unit.

vps_extension_data_flag may have any value. Its presence and value do not affect decoder conformance to profiles specified in Annexes A, G, or H. Decoders conforming to a profile specified in Annexes A, G, or H shall ignore all `vps_extension_data_flag` syntax elements.

F.7.4.3.1.1 Video parameter set extension semantics

splitting_flag equal to 1 indicates that the `dimension_id[i][j]` syntax elements are not present and that the binary representation of the `nuh_layer_id` value in the NAL unit header are split into `NumScalabilityTypes` segments with lengths, in bits, according to the values of `dimension_id_len_minus1[j]` and that the values of `dimension_id[LayerIdxInVps[nuh_layer_id]][j]` are inferred from the `NumScalabilityTypes` segments. `splitting_flag` equal to 0 indicates that the syntax elements `dimension_id[i][j]` are present.

NOTE 1 When `splitting_flag` is equal to 1, scalability identifiers of the present scalability dimensions can be derived from the `nuh_layer_id` syntax element in the NAL unit header by a bit masked copy. The respective bit mask for the *i*-th present scalability dimension is defined by the value of the `dimension_id_len_minus1[i]` syntax element and `dimBitOffset[i]` as specified in the semantics of `dimension_id_len_minus1[j]`.

scalability_mask_flag[i] equal to 1 indicates that `dimension_id` syntax elements corresponding to the *i*-th scalability dimension in Table F.1 are present. `scalability_mask_flag[i]` equal to 0 indicates that `dimension_id` syntax elements corresponding to the *i*-th scalability dimension are not present.

Table F.1 — Mapping of ScalabilityId to scalability dimensions

scalability mask index	Scalability dimension	ScalabilityId mapping
0	Texture or depth	DepthLayerFlag
1	Multiview	ViewOrderIndex
2	Spatial/quality scalability	DependencyId
3	Auxiliary	AuxId
4-15	Reserved	

dimension_id_len_minus1[j] plus 1 specifies the length, in bits, of the `dimension_id[i][j]` syntax element.

ISO/IEC 23008-2:2017(E)

When `splitting_flag` is equal to 1, the following apply:

- The variable `dimBitOffset[0]` is set equal to 0 and for `j` in the range of 1 to `NumScalabilityTypes - 1`, inclusive, `dimBitOffset[j]` is derived as follows:

$$\text{dimBitOffset}[j] = \sum_{\text{dimIdx}=0}^{j-1} (\text{dimension_id_len_minus1}[\text{dimIdx}] + 1) \quad (\text{F-2})$$

- The value of `dimension_id_len_minus1[NumScalabilityTypes - 1]` is inferred to be equal to `5 - dimBitOffset[NumScalabilityTypes - 1]`.
- The value of `dimBitOffset[NumScalabilityTypes]` is set equal to 6.

It is a requirement of bitstream conformance that when `NumScalabilityTypes` is greater than 0, `dimBitOffset[NumScalabilityTypes - 1]` shall be less than 6.

`vps_nuh_layer_id_present_flag` equal to 1 specifies that `layer_id_in_nuh[i]` for `i` from 1 to `MaxLayersMinus1`, inclusive, are present. `vps_nuh_layer_id_present_flag` equal to 0 specifies that `layer_id_in_nuh[i]` for `i` from 1 to `MaxLayersMinus1`, inclusive, are not present.

`layer_id_in_nuh[i]` specifies the value of the `nuh_layer_id` syntax element in VCL NAL units of the `i`-th layer. When `i` is greater than 0, `layer_id_in_nuh[i]` shall be greater than `layer_id_in_nuh[i - 1]`. For any value of `i` in the range of 0 to `MaxLayersMinus1`, inclusive, when not present, the value of `layer_id_in_nuh[i]` is inferred to be equal to `i`.

For `i` from 0 to `MaxLayersMinus1`, inclusive, the variable `LayerIdxInVps[layer_id_in_nuh[i]]` is set equal to `i`.

`dimension_id[i][j]` specifies the identifier of the `j`-th present scalability dimension type of the `i`-th layer. The number of bits used for the representation of `dimension_id[i][j]` is `dimension_id_len_minus1[j] + 1` bits.

Depending on `splitting_flag`, the following apply:

- If `splitting_flag` is equal to 1, for `i` from 0 to `MaxLayersMinus1`, inclusive, and `j` from 0 to `NumScalabilityTypes - 1`, inclusive, `dimension_id[i][j]` is inferred to be equal to $((\text{layer_id_in_nuh}[i] \& ((1 \ll \text{dimBitOffset}[j + 1]) - 1)) \gg \text{dimBitOffset}[j])$.
- Otherwise (`splitting_flag` is equal to 0), for `j` from 0 to `NumScalabilityTypes - 1`, inclusive, `dimension_id[0][j]` is inferred to be equal to 0.

The variable `ScalabilityId[i][smIdx]` specifying the identifier of the `smIdx`-th scalability dimension type of the `i`-th layer, and the variables `DepthLayerFlag[lld]`, `ViewOrderIdx[lld]`, `DependencyId[lld]`, and `AuxId[lld]` specifying the depth flag, view order index, the spatial/quality scalability identifier, and the auxiliary identifier, respectively, of the layer with `nuh_layer_id` equal to `lld` are derived as follows:

```

NumViews = 1
for( i = 0; i <= MaxLayersMinus1; i++ ) {
  lld = layer_id_in_nuh[ i ]
  for( smIdx= 0, j = 0; smIdx < 16; smIdx++ ) {
    if( scalability_mask_flag[ smIdx ] )
      ScalabilityId[ i ][ smIdx ] = dimension_id[ i ][ j++ ]
    else
      ScalabilityId[ i ][ smIdx ] = 0
  }
  DepthLayerFlag[ lld ] = ScalabilityId[ i ][ 0 ]
  ViewOrderIdx[ lld ] = ScalabilityId[ i ][ 1 ]
  DependencyId[ lld ] = ScalabilityId[ i ][ 2 ]
  AuxId[ lld ] = ScalabilityId[ i ][ 3 ]
  if( i > 0 ) {
    newViewFlag = 1
    for( j = 0; j < i; j++ )
      if( ViewOrderIdx[ lld ] == ViewOrderIdx[ layer_id_in_nuh[ j ] ] )
        newViewFlag = 0
    NumViews += newViewFlag
  }
}

```

(F-3)

`AuxId[lld]` equal to 0 specifies the layer with `nuh_layer_id` equal to `lld` does not contain auxiliary pictures. `AuxId[lld]` greater than 0 specifies the type of auxiliary pictures in layer with `nuh_layer_id` equal to `lld` as specified in Table F.2.

Table F.2 — Mapping of AuxId to the type of auxiliary pictures

AuxId	Name of AuxId	Type of auxiliary pictures	SEI message describing interpretation of auxiliary pictures
1	AUX_ALPHA	Alpha plane	Alpha channel information
2	AUX_DEPTH	Depth picture	Depth representation information
3..127		Reserved	
128..159		Unspecified	
160..255		Reserved	

NOTE 2 The interpretation of auxiliary pictures associated with `AuxId` in the range of 128 to 159, inclusive, is specified through means other than the `AuxId` value.

`AuxId[lld]` shall be in the range of 0 to 2, inclusive, or 128 to 159, inclusive, for bitstreams conforming to this version of this document. Although the value of `AuxId[lld]` shall be in the range of 0 to 2, inclusive, or 128 to 159, inclusive, in this version of this document, decoders shall allow values of `AuxId[lld]` in the range of 0 to 255, inclusive.

It is a requirement of bitstream conformance that when `AuxId[lld]` is equal to `AUX_ALPHA` or `AUX_DEPTH`, either of the following apply:

- `chroma_format_idc` is equal to 0 in the active SPS for the layer with `nuh_layer_id` equal to `lld`.

- The value of all decoded chroma samples is equal to $1 \ll (\text{BitDepth}_c - 1)$ in all pictures that have `nuh_layer_id` equal to `lId` and for which this VPS RBSP is the active VPS RBSP.

SEI messages may describe the interpretation of auxiliary pictures, including their possible association with one or more primary pictures.

NOTE 3 Unless constrained by the semantics of the SEI messages specifying the interpretation of auxiliary pictures, it is allowed to have two layers with `nuh_layer_id` values `layerIdA` and `layerIdB` such that `AuxId[layerIdA]` is equal to `AuxId[layerIdB]`, both being greater than 0, and to have all values of `ScalabilityId[LayerIdxInVps[layerIdA]][i]` equal to `ScalabilityId[LayerIdxInVps[layerIdB]][i]` for each value of `i` in the range of 0 to 15, inclusive. SEI messages specifying the interpretation of auxiliary pictures may specify that a picture with `nuh_layer_id` equal to `layerIdA` and a picture with `nuh_layer_id` equal to `layerIdB` in the same access unit may both be associated with the same primary picture.

view_id_len specifies the length, in bits, of the `view_id_val[i]` syntax element.

view_id_val[i] specifies the view identifier of the `i`-th view specified by the VPS. The length of the `view_id_val[i]` syntax element is `view_id_len` bits. When not present, the value of `view_id_val[i]` is inferred to be equal to 0.

For each layer with `nuh_layer_id` equal to `nuhLayerId`, the value `ViewId[nuhLayerId]` is set equal to `view_id_val[ViewOrderIdx[nuhLayerId]]`.

direct_dependency_flag[i][j] equal to 0 specifies that the layer with index `j` is not a direct reference layer for the layer with index `i`. **direct_dependency_flag[i][j]** equal to 1 specifies that the layer with index `j` is a direct reference layer for the layer with index `i`. When **direct_dependency_flag[i][j]** is not present for `i` and `j` in the range of 0 to `MaxLayersMinus1`, it is inferred to be equal to 0.

The variable `DependencyFlag[i][j]` is derived as follows:

```

for( i = 0; i <= MaxLayersMinus1; i++ )
    for( j = 0; j <= MaxLayersMinus1; j++ ) {
        DependencyFlag[ i ][ j ] = direct_dependency_flag[ i ][ j ]
        for( k = 0; k < i; k++ )
            if( direct_dependency_flag[ 0 ][ k ] && DependencyFlag[ k ][ j ] )
                DependencyFlag[ i ][ j ] = 1
    }

```

(F-4)

The variables `NumDirectRefLayers[iNuhLid]`, `IdDirectRefLayer[iNuhLid][d]`, `NumRefLayers[iNuhLid]`, `IdRefLayer[iNuhLid][r]`, `NumPredictedLayers[iNuhLid]`, and `IdPredictedLayer[iNuhLid][p]` are derived as follows:

```

for( i = 0; i <= MaxLayersMinus1; i++ ) {
    iNuhLid = layer_id_in_nuh[ i ]
    for( j = 0, d = 0, r = 0, p = 0; j <= MaxLayersMinus1; j++ ) {
        jNuhLid = layer_id_in_nuh[ j ]
        if( direct_dependency_flag[ i ][ j ] )
            IdDirectRefLayer[ iNuhLid ][ d++ ] = jNuhLid
        if( DependencyFlag[ i ][ j ] )
            IdRefLayer[ iNuhLid ][ r++ ] = jNuhLid
        if( DependencyFlag[ j ][ i ] )
            IdPredictedLayer[ iNuhLid ][ p++ ] = jNuhLid
    }
    NumDirectRefLayers[ iNuhLid ] = d
    NumRefLayers[ iNuhLid ] = r
    NumPredictedLayers[ iNuhLid ] = p
}

```

(F-5)

The variables NumIndependentLayers, NumLayersInTreePartition[i], and TreePartitionLayerIdList[i][j] for i in the range of 0 to NumIndependentLayers – 1, inclusive, and j in the range of 0 to NumLayersInTreePartition[i] – 1, inclusive, are derived as follows:

```

for( i = 0; i <= 63; i++ )
    layerIdInListFlag[ i ] = 0
for( i = 0, k = 0; i <= MaxLayersMinus1; i++ ) {
    iNuhLId = layer_id_in_nuh[ i ]
    if( NumDirectRefLayers[ iNuhLId ] = 0 ) {
        TreePartitionLayerIdList[ k ][ 0 ] = iNuhLId
        for( j = 0, h = 1; j < NumPredictedLayers[ iNuhLId ]; j++ ) {
            predLId = IdPredictedLayer[ iNuhLId ][ j ]
            if( !layerIdInListFlag[ predLId ] ) {
                TreePartitionLayerIdList[ k ][ h++ ] = predLId
                layerIdInListFlag[ predLId ] = 1
            }
        }
        NumLayersInTreePartition[ k++ ] = h
    }
}
NumIndependentLayers = k

```

(F-6)

It is a requirement of bitstream conformance that AuxId[IdDirectRefLayer[nuhLayerIdA][j]] for any values of nuhLayerIdA and j shall be equal to AuxId[nuhLayerIdA], when AuxId[nuhLayerIdA] is in the range of 0 to 2, inclusive.

NOTE 4 In other words, no prediction takes place between layers with a different value of AuxId, when AuxId is in the range of 0 to 2, inclusive.

num_add_layer_sets specifies the number of additional layer sets. The value of num_add_layer_sets shall be in the range of 0 to 1 023, inclusive. When vps_base_layer_available_flag is equal to 0, the value of num_add_layer_sets shall be greater than 0. When not present, the value of num_add_layer_sets is inferred to be equal to 0.

The variable NumLayerSets is derived as follows:

$$\text{NumLayerSets} = \text{vps_num_layer_sets_minus1} + 1 + \text{num_add_layer_sets} \quad (\text{F-7})$$

When num_add_layer_sets is greater than 0, the variables FirstAddLayerSetIdx and LastAddLayerSetIdx are derived as follows:

$$\begin{aligned} \text{FirstAddLayerSetIdx} &= \text{vps_num_layer_sets_minus1} + 1 \\ \text{LastAddLayerSetIdx} &= \text{FirstAddLayerSetIdx} + \text{num_add_layer_sets} - 1 \end{aligned} \quad (\text{F-8})$$

highest_layer_idx_plus1[i][j] specifies the values of NumLayersInIdList[vps_num_layer_sets_minus1 + 1 + i] and LayerSetLayerIdList[vps_num_layer_sets_minus1 + 1 + i][layerNum] as follows:

```

layerNum = 0
lsIdx = vps_num_layer_sets_minus1 + 1 + i
for( treeIdx = 1; treeIdx < NumIndependentLayers; treeIdx++ )
    for( layerCnt = 0; layerCnt < highest_layer_idx_plus1[ i ][ treeIdx ]; layerCnt++ )
        LayerSetLayerIdList[ lsIdx ][ layerNum++ ] =
            TreePartitionLayerIdList[ treeIdx ][ layerCnt ]
NumLayersInIdList[ lsIdx ] = layerNum

```

(F-9)

The value of highest_layer_idx_plus1[i][j] shall be in the range of 0 to NumLayersInTreePartition[j], inclusive.

ISO/IEC 23008-2:2017(E)

The length of the highest_layer_idx_plus1[i][j] syntax element is $\text{Ceil}(\text{Log}_2(\text{NumLayersInTreePartition}[j] + 1))$ bits.

It is a requirement of bitstream conformance that $\text{NumLayersInIdList}[\text{vps_num_layer_sets_minus1} + 1 + i]$ shall be greater than 0.

vps_sub_layers_max_minus1_present_flag equal to 1 specifies that the syntax elements $\text{sub_layers_vps_max_minus1}[i]$ are present. **vps_sub_layers_max_minus1_present_flag** equal to 0 specifies that the syntax elements $\text{sub_layers_vps_max_minus1}[i]$ are not present.

sub_layers_vps_max_minus1[i] plus 1 specifies, for each value of i in the range of $(\text{vps_base_layer_internal_flag} ? 0 : 1)$ to MaxLayersMinus1 , inclusive, the maximum number of temporal sub-layers that may be present in the CVS for the layer with nuh_layer_id equal to $\text{layer_id_in_nuh}[i]$. When $\text{vps_base_layer_internal_flag}$ is equal to 0, $\text{sub_layers_vps_max_minus1}[0]$ constrains the access units for which a decoded picture with nuh_layer_id equal to 0 may be provided by external means as follows: a decoded picture with nuh_layer_id equal to 0 cannot be provided by external means for decoding of an access unit with TemporalId greater than $\text{sub_layers_vps_max_minus1}[0]$. The value of $\text{sub_layers_vps_max_minus1}[i]$ shall be in the range of 0 to $\text{vps_max_sub_layers_minus1}$, inclusive. When not present, the value of $\text{sub_layers_vps_max_minus1}[i]$ is inferred to be equal to $\text{vps_max_sub_layers_minus1}$.

The variable $\text{MaxSubLayersInLayerSetMinus1}[i]$ is derived as follows:

```
for( i = 0; i < NumLayerSets; i++ ) {
    maxSMinus1 = 0
    for( k = 0; k < NumLayersInIdList[ i ]; k++ ) {
        lId = LayerSetLayerIdList[ i ][ k ]
        maxSMinus1 = Max( maxSLMinus1, sub_layers_vps_max_minus1[ LayerIdxInVps[ lId ] ] )
    }
    MaxSubLayersInLayerSetMinus1[ i ] = maxSMinus1
}
```

(F-10)

max_tid_ref_present_flag equal to 1 specifies that the syntax element $\text{max_tid_il_ref_pics_plus1}[i][j]$ is present. **max_tid_ref_present_flag** equal to 0 specifies that the syntax element $\text{max_tid_il_ref_pics_plus1}[i][j]$ is not present.

max_tid_il_ref_pics_plus1[i][j] equal to 0 specifies that non-IRAP pictures with nuh_layer_id equal to $\text{layer_id_in_nuh}[i]$ are not used as source pictures for inter-layer prediction for pictures with nuh_layer_id equal to $\text{layer_id_in_nuh}[j]$. **max_tid_il_ref_pics_plus1[i][j]** greater than 0 specifies that pictures with nuh_layer_id equal to $\text{layer_id_in_nuh}[i]$ and TemporalId greater than $\text{max_tid_il_ref_pics_plus1}[i][j] - 1$ are not used as source pictures for inter-layer prediction for pictures with nuh_layer_id equal to $\text{layer_id_in_nuh}[j]$. When not present, the value of $\text{max_tid_il_ref_pics_plus1}[i][j]$ is inferred to be equal to 7.

default_ref_layers_active_flag equal to 1 specifies that for each picture referring to the VPS, the direct reference layer pictures that belong to all direct reference layers of the layer containing the picture, and that may be used for inter-layer prediction as specified by the values of $\text{sub_layers_vps_max_minus1}[i]$ and $\text{max_tid_il_ref_pics_plus1}[i][j]$ are present in the same access unit as the picture and are included in the inter-layer reference picture set of the picture. **default_ref_layers_active_flag** equal to 0 specifies that the above restriction may or may not apply.

vps_num_profile_tier_level_minus1 plus 1 specifies the number of $\text{profile_tier_level}()$ syntax structures in the VPS. The value of $\text{vps_num_profile_tier_level_minus1}$ shall be in the range of 0 to 63, inclusive. When $\text{vps_max_layers_minus1}$ is greater than 0, the value of $\text{vps_num_profile_tier_level_minus1}$ shall be greater than or equal to 1.

vps_profile_present_flag[i] equal to 1 specifies that profile and tier information is present in the i-th profile_tier_level() syntax structure. vps_profile_present_flag[i] equal to 0 specifies that profile and tier information is not present in the i-th profile_tier_level() syntax structure and is inferred as specified in F.7.4.4.

num_add_olss specifies the number of OLSs in addition to the first NumLayerSets OLSs specified by the VPS. The value of num_add_olss shall be in the range of 0 to 1 023, inclusive. When not present, the value of num_add_olss is inferred to be equal to 0.

default_output_layer_idc specifies the derivation of the output layers for the OLSs with index in the range of 1 to vps_num_layer_sets_minus1, inclusive. default_output_layer_idc equal to 0 specifies that all layers in each of the OLSs with index in the range of 1 to vps_num_layer_sets_minus1, inclusive, are output layers of their respective OLSs. default_output_layer_idc equal to 1 specifies that only the layer with the highest value of nuh_layer_id such that nuh_layer_id equal to nuhLayerIdA in each of the OLSs with index in the range of 1 to vps_num_layer_sets_minus1, inclusive, is an output layer of its OLS. default_output_layer_idc equal to 2 specifies that the output layers for the OLSs with index in the range of 1 to vps_num_layer_sets_minus1, inclusive, are specified with the syntax elements output_layer_flag[i][j]. The value of 3 for default_output_layer_idc is reserved for future use by ITU-T | ISO/IEC. Although the value of default_output_layer_idc is required to be less than 3 in this version of this document, decoders shall allow a value of default_output_layer_idc equal to 3 to appear in the syntax.

The variable defaultOutputLayerIdc is set equal to Min(default_output_layer_idc, 2).

layer_set_idx_for_ols_minus1[i] plus 1 specifies the index of the layer set for the i-th OLS. The value of layer_set_idx_for_ols_minus1[i] shall be in the range of 0 to NumLayerSets – 2, inclusive. The length of the layer_set_idx_for_ols_minus1[i] syntax element is Ceil(Log2(NumLayerSets – 1)) bits. When not present, the value of layer_set_idx_for_ols_minus1[i] is inferred to be equal to 0.

For i in the range of 0 to NumOutputLayerSets – 1, inclusive, the variable OlsIdxToLsIdx[i] is derived as specified in the following:

$$\text{OlsIdxToLsIdx}[i] = (i < \text{NumLayerSets}) ? i : (\text{layer_set_idx_for_ols_minus1}[i] + 1) \quad (\text{F-11})$$

output_layer_flag[i][j] equal to 1 specifies that the j-th layer in the i-th OLS is an output layer. output_layer_flag[i][j] equal to 0 specifies that the j-th layer in the i-th OLS is not an output layer.

The value of output_layer_flag[0][0] is inferred to be equal to 1.

When defaultOutputLayerIdc is equal to 0 or 1, for i in the range of 0 to vps_num_layer_sets_minus1, inclusive, and j in the range of 0 to NumLayersInIdList[OlsIdxToLsIdx[i]] – 1, inclusive, the variable OutputLayerFlag[i][j] is derived as follows:

- If defaultOutputLayerIdc is equal to 0 or LayerSetLayerIdList[OlsIdxToLsIdx[i]][j] is equal to nuhLayerIdA, with nuhLayerIdA being the highest value in LayerSetLayerIdList[OlsIdxToLsIdx[i]], OutputLayerFlag[i][j] is set equal to 1.
- Otherwise, OutputLayerFlag[i][j] is set equal to 0.

For i in the range of (defaultOutputLayerIdc = 2) ? 0 : (vps_num_layer_sets_minus1 + 1) to NumOutputLayerSets – 1, inclusive, and j in the range of 0 to NumLayersInIdList[OlsIdxToLsIdx[i]] – 1, inclusive, the variable OutputLayerFlag[i][j] is set equal to output_layer_flag[i][j].

The variable NumOutputLayersInOutputLayerSet[i] is derived as follows:

$$\begin{aligned} \text{NumOutputLayersInOutputLayerSet}[i] &= 0 \\ \text{for}(j = 0; j < \text{NumLayersInIdList}[\text{OlsIdxToLsIdx}[i]]; j++) \{ \\ \quad \text{NumOutputLayersInOutputLayerSet}[i] &+= \text{OutputLayerFlag}[i][j] \\ \quad \text{if}(\text{OutputLayerFlag}[i][j]) \\ \quad \quad \text{OlsHighestOutputLayerId}[i] &= \text{LayerSetLayerIdList}[\text{OlsIdxToLsIdx}[i]][j] \end{aligned} \quad (\text{F-12})$$

ISO/IEC 23008-2:2017(E)

It is a requirement of bitstream conformance that NumOutputLayersInOutputLayerSet[i] shall be greater than 0 for i in the range of 0 to NumOutputLayerSets – 1, inclusive.

The variables NumNecessaryLayers[olsIdx] and NecessaryLayerFlag[olsIdx][lIdx] are derived as follows:

```
for( olsIdx = 0; olsIdx < NumOutputLayerSets; olsIdx++ ) {
    lsIdx = OlsIdxToLsIdx[ olsIdx ]
    for( lsLayerIdx = 0; lsLayerIdx < NumLayersInLsList[ lsIdx ]; lsLayerIdx++ )
        NecessaryLayerFlag[ olsIdx ][ lsLayerIdx ] = 0
    for( lsLayerIdx = 0; lsLayerIdx < NumLayersInLsList[ lsIdx ]; lsLayerIdx++ )
        if( OutputLayerFlag[ olsIdx ][ lsLayerIdx ] ) {
            NecessaryLayerFlag[ olsIdx ][ lsLayerIdx ] = 1
            currLayerId = LayerSetLayerIdList[ lsIdx ][ lsLayerIdx ]
            for( rLsLayerIdx = 0; rLsLayerIdx < lsLayerIdx; rLsLayerIdx++ ) {
                refLayerId = LayerSetLayerIdList[ lsIdx ][ rLsLayerIdx ]
                if(
                    DependencyFlag[ LayerIdxInVps[ currLayerId ] ][ LayerIdxInVps[ refLayerId ] ]
                    NecessaryLayerFlag[ olsIdx ][ rLsLayerIdx ] = 1
                )
            }
            NumNecessaryLayers[ olsIdx ] = 0
            for( lsLayerIdx = 0; lsLayerIdx < NumLayersInLsList[ lsIdx ]; lsLayerIdx++ )
                NumNecessaryLayers[ olsIdx ] += NecessaryLayerFlag[ olsIdx ][ lsLayerIdx ]
        }
    }
}
```

It is a requirement of bitstream conformance that for each layer index layerIdx in the range of (vps_base_layer_internal_flag ? 0 : 1) to MaxLayersMinus1, inclusive, there shall be at least one OLS with index olsIdx such that NecessaryLayerFlag[olsIdx][lsLayerIdx] is equal to 1 for the value of lsLayerIdx for which LayerSetLayerIdList[OlsIdxToLsIdx[olsIdx]][lsLayerIdx] is equal to layer_id_in_nuh[layerIdx].

NOTE 5 In other words, each layer has to be an output layer or a reference layer of an output layer in at least one OLS.

It is a requirement of bitstream conformance that when num_add_layer_sets is greater than 0 and olsIdx has any such value that OlsIdxToLsIdx[olsIdx] is in the range of FirstAddLayerSetIdx to LastAddLayerSetIdx, inclusive, and NumNecessaryLayers[olsIdx] is equal to 1, NecessaryLayerFlag[olsIdx][0] shall be equal to 1.

NOTE 6 In other words, when an additional layer set has exactly one necessary layer, the necessary layer is required to be the layer with the smallest nuh_layer_id value within the additional layer set.

profile_tier_level_idx[i][j] specifies the index, into the list of profile_tier_level() syntax structures in the VPS, of the profile_tier_level() syntax structure that applies to the j-th layer of the i-th OLS as specified in F.7.4.4. The length of the profile_tier_level_idx[i][j] syntax element is Ceil(Log2(vps_num_profile_tier_level_minus1 + 1)) bits.

When NecessaryLayerFlag[i][j] is equal to 1 and vps_num_profile_tier_level_minus1 is equal to 0, the value of profile_tier_level_idx[i][j] is inferred to be equal to 0.

When vps_base_layer_internal_flag is equal to 1, the following apply:

- If vps_max_layers_minus1 is greater than 0, the value of profile_tier_level_idx[0][0] is inferred to be equal to 1.
- Otherwise (vps_max_layers_minus1 is equal to 0), the value of profile_tier_level_idx[0][0] is inferred to be equal to 0.

When present, the value of `profile_tier_level_idx[i][j]` shall be in the range of $(vps_base_layer_internal_flag ? 0 : 1)$ to `vps_num_profile_tier_level_minus1`, inclusive.

alt_output_layer_flag[*i*] equal to 0 specifies that an alternative output layer is not used for any output layer in the *i*-th OLS. `alt_output_layer_flag`[*i*] equal to 1 specifies that an alternative output layer may be used for the output layer in the *i*-th OLS.

When not present, the value of `alt_output_layer_flag`[*i*] is inferred to be equal to 0.

NOTE 7 When `alt_output_layer_flag`[`olsIdx`] is equal to 0, pictures that do not belong to the output layers of the OLS with index `olsIdx` are not output. When `alt_output_layer_flag`[`olsIdx`] is equal to 1 and a picture belonging to the output layer of the OLS with index `olsIdx` is not present in an access unit or has `PicOutputFlag` equal to 0, a picture with the highest `nuh_layer_id` among those pictures of the access unit for which `PicOutputFlag` is equal to 1 and having the `nuh_layer_id` value among the `nuh_layer_id` values of the reference layers of the output layer is output.

For each value of `olsIdx` in the range of 0 to `NumOutputLayerSets` – 1, inclusive, the following apply:

- When `alt_output_layer_flag`[`olsIdx`] is equal to 1, the value of `pic_output_flag` shall be the same in the slice headers of an access unit that have `nuh_layer_id` value equal to `OlsHighestOutputLayerId`[`olsIdx`] or equal to the `nuh_layer_id` value of any reference layer of the layer with `nuh_layer_id` equal to `OlsHighestOutputLayerId`[`olsIdx`].
- The variable `olsBitstream` is derived as follows:
 - Let `lsIdx` be equal to `OlsIdxToLsIdx`[`olsIdx`].
 - If `lsIdx` is less than or equal to `vps_num_layer_sets_minus1`, let `olsBitstream` be the output of the sub-bitstream extraction process specified in F.10.1 with the following inputs: the current bitstream, `tIdTarget` equal to 6 and `layerIdListTarget` equal to `LayerSetLayerIdList`[`lsIdx`].
 - Otherwise, let `olsBitstream` be the output of the sub-bitstream extraction process specified in F.10.3 with the following inputs: the current bitstream, `tIdTarget` equal to 6 and `layerIdListTarget` equal to `LayerSetLayerIdList`[`lsIdx`].
- Let `truncatedOlsBitstream` be `olsBitstream` or be formed from the `olsBitstream` by removing access units preceding, in decoding order, any access unit with an IRAP picture having `nuh_layer_id` equal to `SmallestLayerId`.
- It is a requirement of bitstream conformance that when `alt_output_layer_flag`[`olsIdx`] is equal to 1, a bitstream that is formed by removing, from the `truncatedOlsBitstream`, any coded picture that is not used as a reference for prediction for any other picture and is not the only coded picture of an access unit is a conforming bitstream.

NOTE 8 When `alt_output_layer_flag`[`olsIdx`] is equal to 1, encoders are required to set the values of `max_vps_dec_pic_buffering_minus1`[*i*][*k*][*j*] such that these values suffice also when pictures of an alternative output layer are marked as "needed for output" in the HRD.

vps_num_rep_formats_minus1 plus 1 specifies the number of the following `rep_format()` syntax structures in the VPS. The value of `vps_num_rep_formats_minus1` shall be in the range of 0 to 255, inclusive.

rep_format_idx_present_flag equal to 1 specifies that the syntax elements `vps_rep_format_idx`[*i*] are present. `rep_format_idx_present_flag` equal to 0 specifies that the syntax elements `vps_rep_format_idx`[*i*] are not present. When not present, the value of `rep_format_idx_present_flag` is inferred to be equal to 0.

vps_rep_format_idx[*i*] specifies the index, into the list of `rep_format()` syntax structures in the VPS, of the `rep_format()` syntax structure that applies to the layer with `nuh_layer_id` equal to `layer_id_in_nuh`[*i*]. When not present, the value of `vps_rep_format_idx`[*i*] is inferred to be equal to

$\text{Min}(i, \text{vps_num_rep_formats_minus1})$. The value of $\text{vps_rep_format_idx}[i]$ shall be in the range of 0 to $\text{vps_num_rep_formats_minus1}$, inclusive. The number of bits used for the representation of $\text{vps_rep_format_idx}[i]$ is $\text{Ceil}(\text{Log2}(\text{vps_num_rep_formats_minus1} + 1))$.

max_one_active_ref_layer_flag equal to 1 specifies that at most one picture is used for inter-layer prediction for each picture in the CVS. **max_one_active_ref_layer_flag** equal to 0 specifies that more than one picture may be used for inter-layer prediction for each picture in the CVS.

vps_poc_lsb_aligned_flag equal to 0 specifies that the value of $\text{slice_pic_order_cnt_lsb}$ may or may not be the same in different pictures of an access unit. **vps_poc_lsb_aligned_flag** equal to 1 specifies that the value of $\text{slice_pic_order_cnt_lsb}$ is the same in all pictures of an access unit. Additionally, the value of **vps_poc_lsb_aligned_flag** affects the decoding process for picture order count in F.8.3.1. When not present, the value of **vps_poc_lsb_aligned_flag** is inferred to be equal to 0.

poc_lsb_not_present_flag[i] equal to 1 specifies that the $\text{slice_pic_order_cnt_lsb}$ syntax element is not present in the slice headers of IDR pictures with nuh_layer_id equal to $\text{layer_id_in_nuh}[i]$ in the CVS. **poc_lsb_not_present_flag**[i] equal to 0 specifies that $\text{slice_pic_order_cnt_lsb}$ syntax element may or may not be present in the slice headers of IDR pictures with nuh_layer_id equal to $\text{layer_id_in_nuh}[i]$ in the CVS. When not present, the value of **poc_lsb_not_present_flag**[i] is inferred to be equal to 0.

direct_dep_type_len_minus2 plus 2 specifies the number of bits of the $\text{direct_dependency_type}[i][j]$ and the $\text{direct_dependency_all_layers_type}$ syntax elements. In bitstreams conforming to this version of this document the value of **direct_dep_type_len_minus2** shall be equal to 0 or 1. Although the value of **direct_dep_type_len_minus2** shall be equal to 0 or 1 in this version of this document, decoders shall allow other values of **direct_dep_type_len_minus2** in the range of 0 to 30, inclusive, to appear in the syntax.

direct_dependency_all_layers_flag equal to 1 specifies that the syntax element $\text{direct_dependency_type}[i][j]$ is not present and inferred from $\text{direct_dependency_all_layers_type}$. **direct_dependency_all_layers_flag** equal to 0 indicates that the syntax element $\text{direct_dependency_type}[i][j]$ is present.

direct_dependency_all_layers_type, when present, specifies the inferred value of $\text{direct_dependency_type}[i][j]$ for all combinations of i -th and j -th layers. The length of the $\text{direct_dependency_all_layers_type}$ syntax element is $\text{direct_dep_type_len_minus2} + 2$ bits. Although the value of $\text{direct_dependency_all_layers_type}$ is required to be in the range of 0 to 6, inclusive, in this version of this document, decoders shall allow values of $\text{direct_dependency_all_layers_type}$ in the range of 0 to $2^{32} - 2$, inclusive, to appear in the syntax.

direct_dependency_type[i][j] indicates the type of dependency between the layer with nuh_layer_id equal to $\text{layer_id_in_nuh}[i]$ and the layer with nuh_layer_id equal to $\text{layer_id_in_nuh}[j]$. **direct_dependency_type**[i][j] equal to 0 specifies that the layer with nuh_layer_id equal to $\text{layer_id_in_nuh}[j]$ may be used for inter-layer sample prediction but is not used for inter-layer motion prediction of the layer with nuh_layer_id equal to $\text{layer_id_in_nuh}[i]$. **direct_dependency_type**[i][j] equal to 1 specifies that the layer with nuh_layer_id equal to $\text{layer_id_in_nuh}[j]$ may be used for inter-layer motion prediction but is not used for inter-layer sample prediction of the layer with nuh_layer_id equal to $\text{layer_id_in_nuh}[i]$. **direct_dependency_type**[i][j] equal to 2 specifies that the layer with nuh_layer_id equal to $\text{layer_id_in_nuh}[j]$ may be used for both inter-layer motion prediction and inter-layer sample prediction of the layer with nuh_layer_id equal to $\text{layer_id_in_nuh}[i]$. The length of the $\text{direct_dependency_type}[i][j]$ syntax element is $\text{direct_dep_type_len_minus2} + 2$ bits. Although the value of $\text{direct_dependency_type}[i][j]$ shall be in the range of 0 to 2, inclusive, when the layer with nuh_layer_id equal to $\text{layer_id_in_nuh}[i]$ conforms to a profile specified in Annexes A, G, or H, and in the range of 0 to 6, inclusive, when the layer with nuh_layer_id equal to $\text{layer_id_in_nuh}[i]$ conforms to a profile specified in Annex I, decoders shall allow values of $\text{direct_dependency_type}[i][j]$ in the range of 0 to $2^{32} - 2$, inclusive, to appear in the syntax.

When **direct_dependency_all_layers_flag** is equal to 1, for any i in the range of $(1 - \text{vps_base_layer_internal_flag}) + 1$ to MaxLayersMinus1 , inclusive, and any j in the range of

1 – vps_base_layer_internal_flag to i – 1, inclusive, when direct_dependency_flag[i][j] is equal to 1, the value of direct_dependency_type[i][j] is inferred to be equal to direct_dependency_all_layers_type.

When vps_base_layer_internal_flag is equal to 0, for any i in the range of 1 to MaxLayersMinus1, inclusive, when direct_dependency_flag[i][0] is equal to 1, the value of direct_dependency_type[i][0] is inferred to be equal to 0.

The variables VpsInterLayerSamplePredictionEnabled[i][j] and VpsInterLayerMotionPredictionEnabled[i][j] are derived as follows:

```

if( direct_dependency_flag[ i ][ j ] )
    VpsInterLayerSamplePredictionEnabled[ i ][ j ] = ( direct_dependency_type[ i ][ j ] + 1 ) & 0x1
else
    VpsInterLayerSamplePredictionEnabled[ i ][ j ] = 0
if( direct_dependency_flag[ i ][ j ] )
    VpsInterLayerMotionPredictionEnabled[ i ][ j ] = ( ( direct_dependency_type[ i ][ j ] + 1 ) & 0x2 ) ? 1 : 0
else
    VpsInterLayerMotionPredictionEnabled[ i ][ j ] = 0

```

(F-14)

vps_non_vui_extension_length specifies the length of the non-VUI VPS extension data following this syntax element and before vps_vui_present_flag, in bytes. The value of vps_non_vui_extension_length shall be in the range of 0 to 4096, inclusive.

vps_non_vui_extension_data_byte may have any value. Decoders shall ignore the value of vps_non_vui_extension_data_byte. Its value does not affect decoder conformance to profiles specified in this version of this document.

vps_vui_present_flag equal to 1 specifies that the vps_vui() syntax structure is present in the VPS. vps_vui_present_flag equal to 0 specifies that the vps_vui() syntax structure is not present in the VPS.

vps_vui_alignment_bit_equal_to_one shall be equal to 1.

F.7.4.3.1.2 Representation format semantics

chroma_and_bit_depth_vps_present_flag equal to 1 specifies that the syntax elements chroma_format_vps_idc, bit_depth_vps_luma_minus8, and bit_depth_vps_chroma_minus8 are present and that the syntax element separate_colour_plane_vps_flag may be present in the rep_format() structure. chroma_and_bit_depth_vps_present_flag equal to 0 specifies that the syntax elements chroma_format_vps_idc, separate_colour_plane_vps_flag, bit_depth_vps_luma_minus8, and bit_depth_vps_chroma_minus8 are not present and are inferred from the previous rep_format() syntax structure in the VPS. The value of chroma_and_bit_depth_vps_present_flag of the first rep_format() syntax structure in the VPS shall be equal to 1.

pic_width_vps_in_luma_samples, **pic_height_vps_in_luma_samples**, **chroma_format_vps_idc**, **separate_colour_plane_vps_flag**, **bit_depth_vps_luma_minus8**, and **bit_depth_vps_chroma_minus8** are used for inference of the values of the SPS syntax elements pic_width_in_luma_samples, pic_height_in_luma_samples, chroma_format_idc, separate_colour_plane_flag, bit_depth_luma_minus8, and bit_depth_chroma_minus8, respectively, for each SPS that refers to the VPS. When not present in the i-th rep_format() syntax structure in the VPS, the value of each of these syntax elements is inferred to be equal to the value of the corresponding syntax element in the (i – 1)-th rep_format() syntax structure in the VPS. pic_width_vps_in_luma_samples shall not be equal to 0 and shall be an integer multiple of MinCbSizeY. pic_height_vps_in_luma_samples shall not be equal to 0 and shall be an integer multiple of MinCbSizeY. The value of chroma_format_vps_idc shall be in the range of 0 to 3, inclusive. bit_depth_vps_luma_minus8 shall be in the range of 0 to 8, inclusive. bit_depth_vps_chroma_minus8 shall be in the range of 0 to 8, inclusive.

conformance_window_vps_flag equal to 1 specifies that the syntax elements conf_win_vps_left_offset, conf_win_vps_right_offset, conf_win_vps_top_offset, and conf_win_vps_bottom_offset follow next in the rep_format() structure. conformance_window_vps_flag equal to 0 specifies that the syntax elements

`conf_win_vps_left_offset`, `conf_win_vps_right_offset`, `conf_win_vps_top_offset`, and `conf_win_vps_bottom_offset` are not present.

`conf_win_vps_left_offset`, **`conf_win_vps_right_offset`**, **`conf_win_vps_top_offset`**, and **`conf_win_vps_bottom_offset`** are used for inference of the values of the SPS syntax elements, `conf_win_left_offset`, `conf_win_right_offset`, `conf_win_top_offset`, and `conf_win_bottom_offset`, respectively, for each SPS that refers to the VPS. When not present, the values of `conf_win_vps_left_offset`, `conf_win_vps_right_offset`, `conf_win_vps_top_offset`, and `conf_win_vps_bottom_offset` are inferred to be equal to 0.

The value of $\text{SubWidthC} * (\text{conf_win_vps_left_offset} + \text{conf_win_vps_right_offset})$ shall be less than `pic_width_vps_in_luma_samples`, and the value of $\text{SubHeightC} * (\text{conf_win_vps_top_offset} + \text{conf_win_vps_bottom_offset})$ shall be less than `pic_height_vps_in_luma_samples`.

F.7.4.3.1.3 DPB size semantics

For the `lsIdx`-th layer set, the number of sub-DPBs is `NumLayersInIdList[lsIdx]`, and for each layer with a particular value of `nuh_layer_id` in the layer set, the sub-DPB with index `layerIdx` is assigned, where `LayerSetLayerIdList[lsIdx][layerIdx]` is equal to `nuh_layer_id`.

`sub_layer_flag_info_present_flag[i]` equal to 1 specifies that `sub_layer_dpb_info_present_flag[i][j]` is present for `j` in the range of 1 to `MaxSubLayersInLayerSetMinus1[OlsIdxToLsIdx[i]]`, inclusive. `sub_layer_flag_info_present_flag[i]` equal to 0 specifies that, for each value of `j` greater than 0, `sub_layer_dpb_info_present_flag[i][j]` is not present.

`sub_layer_dpb_info_present_flag[i][j]` equal to 1 specifies that `max_vps_dec_pic_buffering_minus1[i][k][j]` may be present for `k` in the range of 0 to `NumLayersInIdList[OlsIdxToLsIdx[i]] - 1`, inclusive, for the `j`-th sub-layer of the `i`-th OLS, and `max_vps_num_reorder_pics[i][j]` and `max_vps_latency_increase_plus1[i][j]` are present for the `j`-th sub-layer of the `i`-th OLS. `sub_layer_dpb_info_present_flag[i][j]` equal to 0 specifies that `max_vps_dec_pic_buffering_minus1[i][k][j]` for `k` in the range of 0 to `NumLayersInIdList[OlsIdxToLsIdx[i]] - 1`, inclusive, `max_vps_num_reorder_pics[i][j]`, and `max_vps_latency_increase_plus1[i][j]` are not present. The value of `sub_layer_dpb_info_present_flag[i][0]` for any possible value of `i` is inferred to be equal to 1. When not present, the value of `sub_layer_dpb_info_present_flag[i][j]` for `j` greater than 0 and any possible value of `i`, is inferred to be equal to 0.

`max_vps_dec_pic_buffering_minus1[i][k][j]` plus 1, when `NecessaryLayerFlag[i][k]` is equal to 1, specifies the maximum number of decoded pictures, of the `k`-th layer in the `i`-th OLS for the CVS, that need to be stored in the DPB when `HighestTid` is equal to `j`.

When `NecessaryLayerFlag[i][k]` is equal to 1, the following applies for `i` in the range of 1 to `NumOutputLayerSets - 1`, inclusive:

- When `j` is greater than 0, `max_vps_dec_pic_buffering_minus1[i][k][j]` shall be greater than or equal to `max_vps_dec_pic_buffering_minus1[i][k][j - 1]`.
- When `max_vps_dec_pic_buffering_minus1[i][0][0]` is not present, it is inferred to be equal to 0.
- When `max_vps_dec_pic_buffering_minus1[i][k][j]` is not present for `j` in the range of 1 to `MaxSubLayersInLayerSetMinus1[OlsIdxToLsIdx[i]]`, inclusive, it is inferred to be equal to `max_vps_dec_pic_buffering_minus1[i][k][j - 1]`.

`max_vps_num_reorder_pics[i][j]` specifies, when `HighestTid` is equal to `j`, the maximum allowed number of access units containing a picture with `PicOutputFlag` equal to 1 that can precede any access unit `auA` that contains a picture with `PicOutputFlag` equal to 1 in the `i`-th OLS in the CVS in decoding order and follow the access unit `auA` that contains a picture with `PicOutputFlag` equal to 1 in output order. When `max_vps_num_reorder_pics[i][j]` is not present for `j` in the range of 1 to `MaxSubLayersInLayerSetMinus1[OlsIdxToLsIdx[i]]`, inclusive, due to

`sub_layer_dpb_info_present_flag[i][j]` being equal to 0, it is inferred to be equal to `max_vps_num_reorder_pics[i][j - 1]`.

`max_vps_latency_increase_plus1[i][j]` not equal to 0 is used to compute the value of `MaxVpsLatencyPictures[i][j]`, which, when `HighestTid` is equal to `j`, specifies the maximum number of access units containing a picture with `PicOutputFlag` equal to 1 in the `i`-th OLS that can precede any access unit `auA` that contains a picture with `PicOutputFlag` equal to 1 in the CVS in output order and follow the access unit `auA` that contains a picture with `PicOutputFlag` equal to 1 in decoding order. When `max_vps_latency_increase_plus1[i][j]` is not present for `j` in the range of 1 to `MaxSubLayersInLayerSetMinus1[OlsIdxToLsIdx[i]]`, inclusive, due to `sub_layer_dpb_info_present_flag[i][j]` being equal to 0, it is inferred to be equal to `max_vps_latency_increase_plus1[i][j - 1]`.

When `max_vps_latency_increase_plus1[i][j]` is not equal to 0, the value of `MaxVpsLatencyPictures[i][j]` is specified as follows:

$$\text{MaxVpsLatencyPictures}[i][j] = \text{max_vps_num_reorder_pics}[i][j] + \text{max_vps_latency_increase_plus1}[i][j] - 1 \quad (\text{F-15})$$

When `max_vps_latency_increase_plus1[i][j]` is equal to 0, no corresponding limit is expressed. The value of `max_vps_latency_increase_plus1[i][j]` shall be in the range of 0 to $2^{32} - 2$, inclusive.

F.7.4.3.1.4 VPS VUI semantics

NOTE 1 When `vps_vui_present_flag` is equal to 0, some of the VPS VUI flags, such as `cross_layer_pic_type_aligned_flag`, `tiles_not_in_use_flag`, and `wpp_not_in_use_flag`, are not present and no value is inferred for them. In this case, the semantics of these flags are unspecified, and it is unknown whether the constraints associated with these flags being equal to 1 apply or not; in other words, in this case those constraints could or could not apply.

`cross_layer_pic_type_aligned_flag` equal to 1 specifies that within a CVS that refers to the VPS, all VCL NAL units that belong to an access unit have the same value of `nal_unit_type`. `cross_layer_pic_type_aligned_flag` equal to 0 specifies that within a CVS that refers to the VPS, all VCL NAL units in each access unit may or may not have the same value of `nal_unit_type`.

`cross_layer_irap_aligned_flag` equal to 1 specifies that IRAP pictures in the CVS are cross-layer aligned, i.e. when a picture `pictureA` of a layer `layerA` in an access unit is an IRAP picture, each picture `pictureB` in the same access unit that belongs to a direct reference layer of `layerA` or that belongs to a layer for which `layerA` is a direct reference layer of that layer is an IRAP picture and the VCL NAL units of `pictureB` have the same value of `nal_unit_type` as that of `pictureA`. `cross_layer_irap_aligned_flag` equal to 0 specifies that the above restriction may or may not apply. When not present, the value of `cross_layer_irap_aligned_flag` is inferred to be equal to `vps_vui_present_flag`.

`all_layers_idr_aligned_flag` equal to 1 indicates that within each access unit for which the VCL NAL units refer to the VPS, when one picture is an IRAP picture, all the pictures in the same access unit are IDR pictures and have the same value of `nal_unit_type`. `all_layers_idr_aligned_flag` equal to 0 specifies that the above restriction may or may not apply. When not present, the value of `all_layers_idr_aligned_flag` is inferred to be equal to 0.

`bit_rate_present_vps_flag` equal to 1 specifies that the syntax element `bit_rate_present_flag[i][j]` is present. `bit_rate_present_vps_flag` equal to 0 specifies that the syntax element `bit_rate_present_flag[i][j]` is not present.

`pic_rate_present_vps_flag` equal to 1 specifies that the syntax element `pic_rate_present_flag[i][j]` is present. `pic_rate_present_vps_flag` equal to 0 specifies that the syntax element `pic_rate_present_flag[i][j]` is not present.

`bit_rate_present_flag[i][j]` equal to 1 specifies that the bit rate information for the `j`-th subset of the `i`-th layer set is present. `bit_rate_present_flag[i]` equal to 0 specifies that the bit rate information for the `j`-th subset of the `i`-th layer set is not present. The `j`-th subset of a layer set is derived as follows:

ISO/IEC 23008-2:2017(E)

- If i is less than or equal to $vps_num_layer_sets_minus1$, the j -th subset of a layer set is the output of the sub-bitstream extraction process specified in F.10.1, when it is invoked with $inBitstream$ equal to the layer set, $tIdTarget$ equal to j , and $layerIdListTarget$ equal to the layer identifier list associated with the layer set as inputs.
- Otherwise (i is greater than $vps_num_layer_sets_minus1$), the j -th subset of a layer set is the output of the sub-bitstream extraction process specified in F.10.3, when it is invoked with $inBitstream$ equal to the layer set, $tIdTarget$ equal to j , and $layerIdListTarget$ equal to the layer identifier list associated with the layer set as inputs.

When not present, the value of $bit_rate_present_flag[i][j]$ is inferred to be equal to 0.

pic_rate_present_flag $[i][j]$ equal to 1 specifies that picture rate information for the j -th subset of the i -th layer set is present. **pic_rate_present_flag** $[i][j]$ equal to 0 specifies that picture rate information for the j -th subset of the i -th layer set is not present. When not present, the value of **pic_rate_present_flag** $[i][j]$ is inferred to be equal to 0.

avg_bit_rate $[i][j]$ indicates the average bit rate of the j -th subset of the i -th layer set, in bits per second. The value is given by $BitRateBPS(avg_bit_rate[i][j])$ with the function $BitRateBPS()$ being specified as follows:

$$BitRateBPS(x) = (x \& (2^{14} - 1)) * 10^{(2 + (x \gg 14))} \quad (F-16)$$

The average bit rate is derived according to the access unit removal time specified in F.13. In the following, $bTotal$ is the number of bits in all NAL units of the j -th subset of the i -th layer set, t_1 is the removal time (in seconds) of the first access unit to which the VPS applies, and t_2 is the removal time (in seconds) of the last access unit (in decoding order) to which the VPS applies. With x specifying the value of **avg_bit_rate** $[i][j]$, the following apply:

- If t_1 is not equal to t_2 , the following condition shall be true:

$$(x \& (2^{14} - 1)) = Round(bTotal \div ((t_2 - t_1) * 10^{(2 + (x \gg 14))})) \quad (F-17)$$

- Otherwise (t_1 is equal to t_2), the following condition shall be true:

$$(x \& (2^{14} - 1)) = 0 \quad (F-18)$$

max_bit_rate_layer $[i][j]$ indicates an upper bound for the bit rate of the j -th subset of the i -th layer set in any one-second time window of access unit removal time as specified in F.13. The upper bound for the bit rate in bits per second is given by $BitRateBPS(max_bit_rate_layer[i][j])$. The bit rate values are derived according to the access unit removal time specified in F.13. In the following, t_1 is any point in time (in seconds), t_2 is set equal to $t_1 + 1 \div 100$, and $bTotal$ is the number of bits in all NAL units of access units with a removal time greater than or equal to t_1 and less than t_2 . With x specifying the value of **max_bit_rate_layer** $[i][j]$, the following condition shall be obeyed for all values of t_1 :

$$(x \& (2^{14} - 1)) \geq bTotal \div ((t_2 - t_1) * 10^{(2 + (x \gg 14))}) \quad (F-19)$$

constant_pic_rate_idc $[i][j]$ indicates whether the picture rate of the j -th subset of the i -th layer set is constant. In the following, a temporal segment $tSeg$ is any set of two or more consecutive access units, in decoding order, of the j -th subset of the i -th layer set, $auTotal(tSeg)$ is the number of access units in the temporal segment $tSeg$, $t_1(tSeg)$ is the removal time (in seconds) of the first access unit (in decoding order) of the temporal segment $tSeg$, $t_2(tSeg)$ is the removal time (in seconds) of the last access unit (in decoding order) of the temporal segment $tSeg$, and $avgPicRate(tSeg)$ is the average picture rate in the temporal segment $tSeg$, and is specified as follows:

$$avgPicRate(tSeg) = Round(auTotal(tSeg) * 256 \div (t_2(tSeg) - t_1(tSeg))) \quad (F-20)$$

If the j -th subset of the i -th layer set only contains one or two access units or the value of $\text{avgPicRate}(t_{\text{Seg}})$ is constant over all the temporal segments, the picture rate is constant; otherwise, the picture rate is not constant.

$\text{constant_pic_rate_idc}[i][j]$ equal to 0 indicates that the picture rate of the j -th subset of the i -th layer set is not constant. $\text{constant_pic_rate_idc}[i][j]$ equal to 1 indicates that the picture rate of the j -th subset of the i -th layer set is constant. $\text{constant_pic_rate_idc}[i][j]$ equal to 2 indicates that the picture rate of the j -th subset of the i -th layer set may or may not be constant. The value of $\text{constant_pic_rate_idc}[i][j]$ shall be in the range of 0 to 2, inclusive.

$\text{avg_pic_rate}[i]$ indicates the average picture rate, in units of picture per 256 seconds, of the j -th subset of the layer set. With auTotal being the number of access units in the j -th subset of the i -th layer set, t_1 being the removal time (in seconds) of the first access unit to which the VPS applies, and t_2 being the removal time (in seconds) of the last access unit (in decoding order) to which the VPS applies, the following apply:

- If t_1 is not equal to t_2 , the following condition shall be true:

$$\text{avg_pic_rate}[i] = \text{Round}(\text{auTotal} * 256 \div (t_2 - t_1)) \quad (\text{F-21})$$

- Otherwise (t_1 is equal to t_2), the following condition shall be true:

$$\text{avg_pic_rate}[i] = 0 \quad (\text{F-22})$$

$\text{video_signal_info_idx_present_flag}$ equal to 1 specifies that the syntax elements $\text{vps_num_video_signal_info_minus1}$ is present and the syntax element $\text{vps_video_signal_info_idx}[i]$ may be present. $\text{video_signal_info_idx_present_flag}$ equal to 0 specifies that the syntax elements $\text{vps_num_video_signal_info_minus1}$ and $\text{vps_video_signal_info_idx}[i]$ are not present.

$\text{vps_num_video_signal_info_minus1}$ plus 1 specifies the number of the following $\text{video_signal_info}()$ syntax structures in the VPS. When not present the value of $\text{vps_num_video_signal_info_minus1}$ is inferred to be equal to $\text{MaxLayersMinus1} - (\text{vps_base_layer_internal_flag} ? 0 : 1)$.

$\text{vps_video_signal_info_idx}[i]$ specifies the index, into the list of $\text{video_signal_info}()$ syntax structures in the VPS, of the $\text{video_signal_info}()$ syntax structure that applies to the layer with nuh_layer_id equal to $\text{layer_id_in_nuh}[i]$. If $\text{video_signal_info_idx_present_flag}$ is equal to 0, the value of $\text{vps_video_signal_info_idx}[i]$ for each value of i in the range of $(\text{vps_base_layer_internal_flag} ? 0 : 1)$ to MaxLayersMinus1 , inclusive, is inferred to be equal to i . Otherwise, when $\text{vps_num_video_signal_info_minus1}$ is equal to 0, the value of $\text{vps_video_signal_info_idx}[i]$ for each value of i in the range of $\text{vps_base_layer_internal_flag}$ to MaxLayersMinus1 , inclusive, is inferred to be equal to 0. The value of $\text{vps_video_signal_info_idx}[i]$ for each value of i in the range of $(\text{vps_base_layer_internal_flag} ? 0 : 1)$ to MaxLayersMinus1 , inclusive, shall be in the range of 0 to $\text{vps_num_video_signal_info_minus1}$, inclusive.

$\text{tiles_not_in_use_flag}$ equal to 1 indicates that the value of $\text{tiles_enabled_flag}$ is equal to 0 for each PPS that is referred to by at least one picture referring to the VPS. $\text{tiles_not_in_use_flag}$ equal to 0 indicates that such a restriction may or may not apply.

$\text{tiles_in_use_flag}[i]$ equal to 1 indicates that the value of $\text{tiles_enabled_flag}$ is equal to 1 for each PPS that is referred to by at least one picture of the i -th layer specified by the VPS. $\text{tiles_in_use_flag}[i]$ equal to 0 indicates that such a restriction may or may not apply. When not present, the value of $\text{tiles_in_use_flag}[i]$ is inferred to be equal to 0.

$\text{loop_filter_not_across_tiles_flag}[i]$ equal to 1 indicates that the value of $\text{loop_filter_across_tiles_enabled_flag}$ is equal to 0 for each PPS that is referred to by at least one picture of the i -th layer specified by the VPS. $\text{loop_filter_not_across_tiles_flag}[i]$ equal to 0 indicates that such a restriction may or may not apply. When not present, the value of $\text{loop_filter_not_across_tiles_flag}[i]$ is inferred to be equal to 0.

tile_boundaries_aligned_flag[i][j] equal to 1 indicates that, when any two samples of one picture of the i-th layer specified by the VPS belong to one tile, the two collocated samples, when both present in the picture of the j-th direct reference layer of the i-th layer, belong to one tile, and when any two samples of one picture of the i-th layer belong to different tiles, the two collocated samples, when both present in the picture of the j-th direct reference layer of the i-th layer belong to different tiles. **tile_boundaries_aligned_flag** equal to 0 indicates that such a restriction may or may not apply. When not present, the value of **tile_boundaries_aligned_flag**[i][j] is inferred to be equal to 0.

wpp_not_in_use_flag equal to 1 indicates that the value of **entropy_coding_sync_enabled_flag** is equal to 0 for each PPS that is referred to by at least one picture referring to the VPS. **wpp_not_in_use_flag** equal to 0 indicates that such a restriction may or may not apply.

wpp_in_use_flag[i] equal to 1 indicates that the value of **entropy_coding_sync_enabled_flag** is equal to 1 for each PPS that is referred to by at least one picture of the i-th layer specified by the VPS. **wpp_in_use_flag**[i] equal to 0 indicates that such a restriction may or may not apply. When not present, the value of **wpp_in_use_flag**[i] is inferred to be equal to 0.

single_layer_for_non_irap_flag equal to 1 indicates the following:

- If **vps_base_layer_internal_flag** is equal to 1, **single_layer_for_non_irap_flag** equal to 1 indicates that either one of the following is true for each access unit for which this VPS is the active VPS:
 - All the VCL NAL units of an access unit have the same **nuh_layer_id** value.
 - Two **nuh_layer_id** values are used by the VCL NAL units of an access unit and the picture with the greater **nuh_layer_id** value is an IRAP picture.
- Otherwise (**vps_base_layer_internal_flag** is equal to 0), **single_layer_for_non_irap_flag** equal to 1 indicates that any one of the following is true for each access unit for which this VPS is the active VPS:
 - The decoded picture with **nuh_layer_id** equal to 0 is not provided for the access unit by external means and the access unit contains one coded picture.
 - The decoded picture with **nuh_layer_id** equal to 0 is not provided for the access unit by external means, the access unit contains two coded pictures, and the picture with the greater **nuh_layer_id** value is an IRAP picture.
 - The decoded picture with **nuh_layer_id** equal to 0 is provided for an access unit by external means and the access unit contains one coded picture that is an IRAP picture.

single_layer_for_non_irap_flag equal to 0 indicates that the above constraints may or may not apply. When not present, the value of **single_layer_for_non_irap_flag** is inferred to be equal to 0.

higher_layer_irap_skip_flag equal to 1 indicates that each IRAP picture **currIrapPic** is constrained as specified below. **currIrapPic** is derived as follows for each access unit **currAu** for which this VPS is the active VPS:

- If **vps_base_layer_internal_flag** is equal to 1, **currAu** contains two coded pictures, and the picture with the greater **nuh_layer_id** value is an IRAP picture, let **currIrapPic** be that IRAP picture.
- Otherwise, if **vps_base_layer_internal_flag** is equal to 0, a decoded picture with **nuh_layer_id** equal to 0 is not provided for **currAu** by external means, **currAu** contains two coded pictures, and the picture with the greater **nuh_layer_id** value is an IRAP picture, let **currIrapPic** be that IRAP picture.
- Otherwise, if **vps_base_layer_internal_flag** is equal to 0, the decoded picture with **nuh_layer_id** equal to 0 is provided for **currAu** by external means and the access unit contains one coded picture that is an IRAP picture, let **currIrapPic** be that IRAP picture.

— Otherwise, `currIrapPic` is not derived for `currAu`.

The following constraints apply for each picture `currIrapPic`:

- For all slices of the IRAP picture:
 - `slice_type` shall be equal to `P`.
 - `slice_sao_luma_flag` and `slice_sao_chroma_flag` shall both be equal to 0.
 - `five_minus_max_num_merge_cand` shall be equal to 4.
 - `weighted_pred_flag` shall be equal to 0 in the PPS that is referred to by the slices.
- For all coding units of the IRAP picture:
 - `cu_skip_flag[i][j]` shall be equal to 1.

When `single_layer_for_non_irap_flag` is equal to 0, `higher_layer_irap_skip_flag` shall be equal to 0. When `higher_layer_irap_skip_flag` is not present it is inferred to be equal to 0.

NOTE 2 When `vps_base_layer_internal_flag` is equal to 1, an encoder may set `single_layer_for_non_irap_flag` equal to 1 as an indication to a decoder that at most two pictures are present in any access unit and whenever there are two pictures in the same access unit, the one with the higher value of `nuh_layer_id` is an IRAP picture. The encoder may additionally set `higher_layer_irap_skip_flag` equal to 1 as an indication to a decoder that whenever there are two pictures in the same access unit, the one with the higher value of `nuh_layer_id` is an IRAP picture for which the decoded samples can be derived by applying the inter-layer reference picture derivation process specified in H.8.1.4 with the other picture with the lower value of `nuh_layer_id` as input.

`ilp_restricted_ref_layers_flag` equal to 1 indicates that additional restrictions on inter-layer prediction as specified below apply for each direct reference layer of each layer specified by the VPS. `ilp_restricted_ref_layers_flag` equal to 0 indicates that additional restrictions on inter-layer prediction may or may not apply. When not present, the value of `ilp_restricted_ref_layers_flag` is inferred to be equal to 0.

`min_spatial_segment_offset_plus1[i][j]` indicates the spatial region, in each picture of the `j`-th direct reference layer of the `i`-th layer, that is not used for inter-layer prediction for decoding of any picture of the `i`-th layer, by itself or together with `min_horizontal_ctu_offset_plus1[i][j]`, as specified below.

The variables `refLayerPicWidthInCtbsY[i][j]` and `refLayerPicHeightInCtbsY[i][j]` are set equal to `PicWidthInCtbsY` and `PicHeightInCtbsY`, respectively, of the `j`-th direct reference layer of the `i`-th layer.

The value of `min_spatial_segment_offset_plus1[i][j]` shall be in the range of 0 to `refLayerPicWidthInCtbsY[i][j] * refLayerPicHeightInCtbsY[i][j]`, inclusive. When not present, the value of `min_spatial_segment_offset_plus1[i][j]` is inferred to be equal to 0.

`ctu_based_offset_enabled_flag[i][j]` equal to 1 specifies that the spatial region, in units of CTUs, in each picture of the `j`-th direct reference layer of the `i`-th layer, that is not used for inter-layer prediction for decoding of any picture of the `i`-th layer is indicated by `min_spatial_segment_offset_plus1[i][j]` and `min_horizontal_ctu_offset_plus1[i][j]` together. `ctu_based_offset_enabled_flag[i][j]` equal to 0 specifies that the spatial region, in units of slice segments, tiles, or CTU rows, in each picture of the `j`-th direct reference layer of the `i`-th layer, that is not used for inter-layer prediction for decoding of any picture of the `i`-th layer is indicated by `min_spatial_segment_offset_plus1[i]` only. When not present, the value of `ctu_based_offset_enabled_flag[i]` is inferred to be equal to 0.

`min_horizontal_ctu_offset_plus1[i][j]`, when `ctu_based_offset_enabled_flag[i][j]` is equal to 1, indicates the spatial region, in each picture of the `j`-th direct reference layer of the `i`-th layer, that is not used for inter-layer prediction for decoding of any picture of the `i`-th layer, together with `min_spatial_segment_offset_plus1[i][j]`, as specified below. The value of

ISO/IEC 23008-2:2017(E)

$\text{min_horizontal_ctu_offset_plus1}[i][j]$ shall be in the range of 0 to $\text{refLayerPicWidthInCtbsY}[i][j]$, inclusive.

When $\text{ctu_based_offset_enabled_flag}[i][j]$ is equal to 1, the variable $\text{minHorizontalCtbOffset}[i][j]$ is derived as follows:

$$\text{minHorizontalCtbOffset}[i][j] = (\text{min_horizontal_ctu_offset_plus1}[i][j] > 0) ? \quad (\text{F-23}) \\ (\text{min_horizontal_ctu_offset_plus1}[i][j] - 1) : (\text{refLayerPicWidthInCtbsY}[i][j] - 1)$$

For any i in the range of 1 to MaxLayersMinus1 , inclusive, and any j in the range of 0 to $\text{NumDirectRefLayers}[\text{layer_id_in_nuh}[i]]$, inclusive, when $\text{min_spatial_segment_offset_plus1}[i][j]$ is greater than 0, it is a requirement of bitstream conformance that the following shall apply:

- Let picA be a picture in the i -th layer, and let picB be the direct reference layer picture of picA with nuh_layer_id equal to $\text{IdDirectRefLayer}[\text{layer_id_in_nuh}[i]][j]$. The variable $\text{colCtbAddr}[i][j]$ that denotes the raster scan address of the collocated CTU, in the direct reference layer picture picB , of the CTU with raster scan address equal to $\text{ctbAddr}[i]$ in picA is derived as specified in the following:
 - The variables curPicWidthY , curPicHeightY , curCtbLog2SizeY and $\text{curPicWidthInCtbsY}$ are set equal to $\text{pic_width_in_luma_samples}$, $\text{pic_height_in_luma_samples}$, CtbLog2SizeY and PicWidthInCtbsY , respectively, of the i -th layer picture picA .
 - The variables refPicWidthY , refPicHeightY , refCtbLog2SizeY , and $\text{refPicWidthInCtbsY}$ are set equal to $\text{pic_width_in_luma_samples}$, $\text{pic_height_in_luma_samples}$, CtbLog2SizeY , and PicWidthInCtbsY , respectively, of the direct reference layer picture picB .
 - If $\text{scaled_ref_layer_offset_present_flag}[\text{IdDirectRefLayer}[\text{layer_id_in_nuh}[i]][j]]$ in the PPS referred to by the i -th layer picture picA is equal to 1, the variables scaledLeftOffset , scaledTopOffset , scaledRightOffset and $\text{scaledBottomOffset}$ are set equal to the left scaled reference layer offset $\text{ScaledRefLayerLeftOffset}$, the top scaled reference layer offset $\text{ScaledRefLayerTopOffset}$, the right scaled reference layer offset $\text{ScaledRefLayerRightOffset}$ and the bottom scaled reference layer offset $\text{ScaledRefLayerBottomOffset}$, respectively, for the direct reference layer picture picB of the i -th layer picture picA .
 - Otherwise ($\text{scaled_ref_layer_offset_present_flag}[\text{IdDirectRefLayer}[\text{layer_id_in_nuh}[i]][j]]$ is equal to 0), the variables scaledLeftOffset , scaledTopOffset , scaledRightOffset and $\text{scaledBottomOffset}$ are set equal to 0.
 - If $\text{ref_region_offset_present_flag}[\text{IdDirectRefLayer}[\text{layer_id_in_nuh}[i]][j]]$ in the PPS referred to by the i -th layer picture picA is equal to 1, the variables $\text{refRegionLeftOffset}$, $\text{refRegionTopOffset}$, $\text{refRegionRightOffset}$ and $\text{refRegionBottomOffset}$ are set equal to the left reference region offset $\text{RefLayerRegionLeftOffset}$, the top reference region offset $\text{RefLayerRegionTopOffset}$, the right reference region offset $\text{RefLayerRegionRightOffset}$ and the bottom reference region offset $\text{RefLayerRegionBottomOffset}$, respectively, for the direct reference layer picture picB of the i -th layer picture picA .
 - Otherwise ($\text{ref_region_offset_present_flag}[\text{IdDirectRefLayer}[\text{layer_id_in_nuh}[i]][j]]$ is equal to 0), the variables $\text{refRegionLeftOffset}$, $\text{refRegionTopOffset}$, $\text{refRegionRightOffset}$ and $\text{refRegionBottomOffset}$ are set equal to 0.
 - The variables (xP, yP) specifying the location of the top-left luma sample of the CTU with raster scan address equal to ctbAddr relative to top-left luma sample in picA are derived as follows:

$$xP = (\text{ctbAddr}[i] \% \text{curPicWidthInCtbsY}) \ll \text{curCtbLog2SizeY} \quad (\text{F-24})$$

$$yP = (ctbAddr[i] / curPicWidthInCtbsY) \ll curCtbLog2SizeY \quad (F-25)$$

- The variables (xPCol, yPCol) specifying the collocated luma sample location in picB of the luma sample location (xP, yP) in picA are derived as follows:

$$refRegionWidth = refPicWidthY - refRegionLeftOffset - refRegionRightOffset \quad (F-26)$$

$$refRegionHeight = refPicHeightY - refRegionTopOffset - refRegionBottomOffset \quad (F-27)$$

$$scaledRefRegionWidth = curPicHeightY - scaledLeftOffset - scaledRightOffset \quad (F-28)$$

$$scaledRefRegionHeight = curPicHeightY - scaledTopOffset - scaledBottomOffset \quad (F-29)$$

$$scaleX = ((refRegionWidth \ll 16) + (scaledRefRegionWidth \gg 1)) / scaledRefRegionWidth \quad (F-30)$$

$$scaleY = ((refRegionHeight \ll 16) + (scaledRefRegionHeight \gg 1)) / scaledRefRegionHeight \quad (F-31)$$

$$xPCol = Clip3(0, (refPicWidthY - 1), (((xP - scaledLeftOffset) * scaleX + (1 \ll 15)) \gg 16) + refRegionLeftOffset) \quad (F-32)$$

$$yPCol = Clip3(0, (refPicHeightY - 1), (((yP - scaledTopOffset) * scaleY + (1 \ll 15)) \gg 16) + refRegionTopOffset) \quad (F-33)$$

- The variable colCtbAddr[i][j] is derived as follows:

$$xColCtb[i][j] = xPCol \gg refCtbLog2SizeY \quad (F-34)$$

$$yColCtb[i][j] = yPCol \gg refCtbLog2SizeY \quad (F-35)$$

$$colCtbAddr[i][j] = xColCtb[i][j] + (yColCtb[i][j] * refPicWidthInCtbsY) \quad (F-36)$$

- If ctu_based_offset_enabled_flag[i][j] is equal to 0, exactly one of the following apply:
 - In each PPS referred to by a picture in the j-th direct reference layer of the i-th layer, tiles_enabled_flag is equal to 0 and entropy_coding_sync_enabled_flag is equal to 0, and the following applies:
 - Let slice segment A be any slice segment of a picture of the i-th layer and ctbAddr[i] be the raster scan address of the last CTU in slice segment A. Let slice segment B be the slice segment that belongs to the same access unit as slice segment A, belongs to the j-th direct reference layer of the i-th layer, and contains the CTU with raster scan address colCtbAddr[i][j]. Let slice segment C be the slice segment that is in the same picture as slice segment B and follows slice segment B in decoding order, and between slice segment B and slice segment C there are min_spatial_segment_offset_plus1[i] - 1 slice segments in decoding order. When slice segment C is present, the syntax elements of slice segment A are constrained such that no sample or syntax elements values in slice segment C or any slice segment of the same picture following slice segment C in decoding order are used for inter-layer prediction in the decoding process of any samples within slice segment A.
 - In each PPS referred to by a picture in the j-th direct reference layer of the i-th layer, tiles_enabled_flag is equal to 1 and entropy_coding_sync_enabled_flag is equal to 0, and the following applies:

- Let tile A be any tile in any picture picA of the i-th layer and ctbAddr[i] be the raster scan address of the last CTU in tile A. Let tile B be the tile that is in the picture picB belonging to the same access unit as picA and belonging to the j-th direct reference layer of the i-th layer and that contains the CTU with raster scan address colCtbAddr[i][j]. Let tile C be the tile that is also in picB and follows tile B in decoding order, and between tile B and tile C there are min_spatial_segment_offset_plus1[i] – 1 tiles in decoding order. When tile C is present, the syntax elements of tile A are constrained such that no sample or syntax elements values in tile C or any tile of the same picture following tile C in decoding order are used for inter-layer prediction in the decoding process of any samples within tile A.
- In each PPS referred to by a picture in the j-th direct reference layer of the i-th layer, tiles_enabled_flag is equal to 0 and entropy_coding_sync_enabled_flag is equal to 1, and the following applies:
 - Let CTU row A be any CTU row in any picture picA of the i-th layer and ctbAddr[i] be the raster scan address of the last CTU in CTU row A. Let CTU row B be the CTU row that is in the picture picB belonging to the same access unit as picA and belonging to the j-th direct reference layer of the i-th layer and that contains the CTU with raster scan address colCtbAddr[i][j]. Let CTU row C be the CTU row that is also in picB and follows CTU row B in decoding order, and between CTU row B and CTU row C there are min_spatial_segment_offset_plus1[i] – 1 CTU rows in decoding order. When CTU row C is present, the syntax elements of CTU row A are constrained such that no sample or syntax elements values in CTU row C or row of the same picture following CTU row C are used for inter-layer prediction in the decoding process of any samples within CTU row A.
- Otherwise (ctu_based_offset_enabled_flag[i][j] is equal to 1), the following apply:
 - The variable refCtbAddr[i][j] is derived as follows:

$$xOffset[i][j] = ((xColCtb[i][j] + minHorizontalCtbOffset[i][j]) > (refPicWidthInCtbsY[i][j] - 1)) ? (refPicWidthInCtbsY[i][j] - 1 - xColCtb[i][j]) : minHorizontalCtbOffset[i][j] \quad (F-37)$$

$$yOffset[i][j] = (min_spatial_segment_offset_plus1[i][j] - 1) * refPicWidthInCtbsY[i][j] \quad (F-38)$$

$$refCtbAddr[i][j] = colCtbAddr[i][j] + xOffset[i][j] + yOffset[i][j] \quad (F-39)$$
 - Let CTU A be any CTU in any picture picA of the i-th layer, and ctbAddr[i] be the raster scan address ctbAddr of CTU A. Let CTU B be a CTU that is in the picture belonging to the same access unit as picA and belonging to the j-th direct reference layer of the i-th layer and that has raster scan address greater than refCtbAddr[i][j]. When CTU B is present, the syntax elements of CTU A are constrained such that no sample or syntax elements values in CTU B are used for inter-layer prediction in the decoding process of any samples within CTU A.

vps_vui_bsp_hrd_present_flag equal to 0 specifies that no bitstream partition HRD parameters are present in the VPS VUI. vps_vui_bsp_hrd_present_flag equal to 1 specifies that bitstream partition HRD parameters are present in the VPS VUI. When vps_timing_info_present_flag is equal to 0, the value of vps_vui_bsp_hrd_present_flag shall be equal to 0.

base_layer_parameter_set_compatibility_flag[i] equal to 1 specifies that the following constraints apply to the layer with nuh_layer_id equal to layer_id_in_nuh[i].

base_layer_parameter_set_compatibility_flag[i] equal to 0 specifies that the following constraints may or may not apply to the layer with nuh_layer_id equal to layer_id_in_nuh[i].

- Each coded slice segment NAL unit with `nuh_layer_id` value equal to `layer_id_in_nuh[i]` referring to the VPS shall refer to a PPS with `nuh_layer_id` value equal to 0.
- Each coded slice segment NAL unit with `nuh_layer_id` value equal to `layer_id_in_nuh[i]` referring to the VPS shall refer to a SPS with `nuh_layer_id` value equal to 0.
- The values of `chroma_format_idc`, `separate_colour_plane_flag`, `pic_width_in_luma_samples`, `pic_height_in_luma_samples`, `bit_depth_luma_minus8`, `bit_depth_chroma_minus8`, `conf_win_left_offset`, `conf_win_right_offset`, `conf_win_top_offset`, and `conf_win_bottom_offset`, respectively, of the active SPS for the layer with `nuh_layer_id` equal to `layer_id_in_nuh[i]` shall be the same as the values of `chroma_format_vps_idc`, `separate_colour_plane_vps_flag`, `pic_width_vps_in_luma_samples`, `pic_height_vps_in_luma_samples`, `bit_depth_vps_luma_minus8`, `bit_depth_vps_chroma_minus8`, `conf_win_vps_left_offset`, `conf_win_vps_right_offset`, `conf_win_vps_top_offset`, and `conf_win_vps_bottom_offset`, respectively, of the `vps_rep_format_idx[i]`-th `rep_format()` syntax structure in the active VPS.

F.7.4.3.1.5 Video signal info semantics

video_vps_format, **video_full_range_vps_flag**, **colour primaries_vps**, **transfer characteristics_vps**, and **matrix_coeffs_vps** are used for inference of the values of the SPS VUI syntax elements `video_format`, `video_full_range_flag`, `colour primaries`, `transfer characteristics`, and `matrix_coeffs`, respectively, for each SPS that refers to the VPS.

For each of these syntax elements, all constraints, if any, that apply to the value of the corresponding SPS VUI syntax element also apply.

F.7.4.3.1.6 VPS VUI bitstream partition HRD parameters semantics

vps_num_add_hrd_params specifies the number of additional `hrd_parameters()` syntax structures present in the VPS. The value of `vps_num_add_hrd_params` shall be in the range of 0 to $1024 - \text{vps_num_hrd_parameters}$, inclusive.

cprms_add_present_flag[i] equal to 1 specifies that the HRD parameters that are common for all sub-layers are present in the *i*-th `hrd_parameters()` syntax structure. **cprms_add_present_flag[i]** equal to 0 specifies that the HRD parameters that are common for all sub-layers are not present in the *i*-th `hrd_parameters()` syntax structure and are derived to be the same as the $(i - 1)$ -th `hrd_parameters()` syntax structure. When `vps_num_hrd_parameters` is equal to 0, the value of `cprms_add_present_flag[0]` is inferred to be equal to 1.

num_sub_layer_hrd_minus1[i] plus 1 specifies the number of sub-layers for which HRD parameters are signalled in the *i*-th `hrd_parameters()` syntax structure. The value of `num_sub_layer_hrd_minus1[i]` shall be in the range of 0 to `vps_max_sub_layers_minus1`, inclusive.

num_signalled_partitioning_schemes[h] specifies the number of signalled partitioning schemes for the *h*-th OLS. The value of `num_signalled_partitioning_schemes[h]` shall be in the range of 0 to 16, inclusive. When `vps_base_layer_internal_flag` is equal to 1, the value of `num_signalled_partitioning_schemes[0]` is inferred to be equal to 0.

num_partitions_in_scheme_minus1[h][j] plus 1 specifies the number of bitstream partitions for the *j*-th partitioning scheme of the *h*-th OLS. The value of `num_partitions_in_scheme_minus1[h][j]` shall be in the range of 0 to `NumLayersInIdList[OlsIdxToLsIdx[h]] - 1`, inclusive. When `vps_base_layer_internal_flag` is equal to 1, the value of `num_partitions_in_scheme_minus1[0][0]` is inferred to be equal to 0. The value of `num_partitions_in_scheme_minus1[h][0]` is inferred to be equal to `NumLayersInIdList[h] - 1`.

NOTE The 0-th partitioning scheme for each OLS is inferred to contain the number of bitstream partitions to be equal to the number of layers in the OLS and each bitstream partition contains one layer of the OLS.

layer_included_in_partition_flag[h][j][k][r] equal to 1 specifies that the r-th layer in the h-th OLS is included in the k-th bitstream partition of the j-th partitioning scheme of the h-th OLS. **layer_included_in_partition_flag**[h][j][k][r] equal to 0 specifies that the r-th layer in the h-th OLS is not included in the k-th bitstream partition of the j-th partitioning scheme of the h-th OLS. When **vps_base_layer_internal_flag** is equal to 1, the value of **layer_included_in_partition_flag**[0][0][0][0] is inferred to be equal to 1. The value of **layer_included_in_partition_flag**[h][0][k][r] for any value of h in the range of 1 to **NumOutputLayerSets** – 1, inclusive, is inferred to be equal to (k = r).

It is a requirement of bitstream conformance that the following constraints apply:

- For the j-th partitioning scheme of the h-th OLS, the bitstream partition with index k1 shall not include reference layers of any layers in the bitstream partition with index k2 for any values of k1 and k2 in the range of 0 to **num_partitions_in_scheme_minus1**[h][j], inclusive, such that k2 is less than k1.
- When **vps_base_layer_internal_flag** is equal to 0 and **layer_included_in_partition_flag**[h][j][k][0] is equal to 1 for any value of h in the range of 1 to **NumOutputLayerSets** – 1, inclusive, any value of j in the range of 0 to **num_signalled_partitioning_schemes**[h], inclusive, and any value of k in the range of 0 to **num_partitions_in_scheme_minus1**[h][j], inclusive, the value of **layer_included_in_partition_flag**[h][j][k][r] for at least one value of r in the range of 1 to **NumLayersInIdxList**[OlsIdxToLsIdx[h]] – 1, inclusive, shall be equal to 1.
- For each partitioning scheme with index j of the h-th OLS, and for each layer with layer index r among the layers in the h-th OLS, there exists one and only one value of k in the range of 0 to **num_partitions_in_scheme_minus1**[h][j], inclusive, such that **layer_included_in_partition_flag**[h][j][k][r] is equal to 1.

num_bsp_schedules_minus1[h][i][t] plus 1 specifies the number of delivery schedules specified for bitstream partitions of the i-th partitioning scheme of the h-th OLS when **HighestTid** is equal to t. The value of **num_bsp_schedules_minus1**[h][i][t] shall be in the range of 0 to 31, inclusive.

The variable **BspSchedCnt**[h][i][t] is set equal to **num_bsp_schedules_minus1**[h][i][t] + 1.

bsp_hrd_idx[h][i][t][j][k] specifies the index of the **hrd_parameters**() syntax structure in the VPS for the j-th delivery schedule specified for the k-th bitstream partition of the i-th partitioning scheme for the h-th OLS when **HighestTid** is equal to t. The length of the **bsp_hrd_idx**[h][i][t][j][k] syntax element is **Ceil**(**Log2**(**vps_num_hrd_parameters** + **vps_num_add_hrd_params**)) bits. The value of **bsp_hrd_idx**[h][i][t][j][k] shall be in the range of 0 to **vps_num_hrd_parameters** + **vps_num_add_hrd_params** – 1, inclusive. When **vps_num_hrd_parameters** + **vps_num_add_hrd_params** is equal to 1, the value of **bsp_hrd_idx**[h][i][t][j][k] is inferred to be equal to 0.

bsp_sched_idx[h][i][t][j][k] specifies the index of the delivery schedule within the **sub_layer_hrd_parameters**(t) syntax structure of the **hrd_parameters**() syntax structure with the index **bsp_hrd_idx**[h][i][t][j][k], that is used as the j-th delivery schedule specified for the k-th bitstream partition of the i-th partitioning scheme for the h-th OLS when **HighestTid** is equal to t. The value of **bsp_sched_idx**[h][i][t][j][k] shall be in the range of 0 to **cpb_cnt_minus1**[t], inclusive, where **cpb_cnt_minus1**[t] is found in the **hrd_parameters**() syntax structure corresponding to the index **bsp_hrd_idx**[h][i][t][j][k].

The following applies for any j greater than 0, any h in the range of 1 to **NumOutputLayerSets** – 1, inclusive, any i in the range 0 to **num_signalled_partitioning_schemes**[h], inclusive, any t in the range of 0 to **MaxSubLayersInLayerSetMinus1**[OlsIdxToLsIdx[h]], inclusive, and any k in the range of 0 to **num_partitions_in_scheme_minus1**[h][i], inclusive:

- For x in the range of 0 to 1, inclusive, the following apply:

- The variable `bsIdx` is set equal to `bsp_sched_idx[h][i][t][j - x][k]`.
- The variables `bitRateValueMinus1[x]`, `bitRateDuValueMinus1[x]`, `cpbSizeValueMinus1[x]`, and `cpbSizeDuValueMinus1[x]` are set equal to the values of the syntax elements `bit_rate_value_minus1[bsIdx]`, `bit_rate_du_value_minus1[bsIdx]`, `cpb_size_value_minus1[bsIdx]`, and `cpb_size_du_value_minus1[bsIdx]`, respectively, found in the `sub_layer_hrd_parameters(t)` syntax structure within the `hrd_parameters()` structure with index `bsp_hrd_idx[h][i][t][j - x][k]`.
- It is a requirement of bitstream conformance that all of the following conditions shall be true:
 - `bitRateValueMinus1[0]` is greater than `bitRateValueMinus1[1]`.
 - `bitRateDuValueMinus1[0]` is greater than `bitRateDuValueMinus1[1]`.
 - `cpbSizeValueMinus1[0]` is less than or equal to `cpbSizeValueMinus1[1]`.
 - `cpbSizeDuValueMinus1[0]` is less than or equal to `cpbSizeDuValueMinus1[1]`.

The arrays `BpBitRate` and `BpbSize` for BPB are derived as follows:

```

for( h = 1; h < NumOutputLayerSets; h++ )
  for( i = 0; i <= num_signalled_partitioning_schemes[ h ]; i++ )
    for( t = 0; t <= MaxSubLayersInLayerSetMinus1[ OlsIdxToLsIdx[ h ] ]; t++ )
      for( j = 0; j <= num_bsp_schedules_minus1[ h ][ i ][ t ]; j++ )
        for( k = 0; k <= num_partitions_in_scheme_minus1[ h ][ i ][ t ][ j ]; k++ ) {
          bsIdx = bsp_sched_idx[ h ][ i ][ t ][ j ][ k ]
          brDu = ( bit_rate_du_value_minus1[ bsIdx ] + 1 ) * 2(6 + bit_rate_scale)
          brPu = ( bit_rate_value_minus1[ bsIdx ] + 1 ) * 2(6 + bit_rate_scale)
          cpbSizeDu = ( cpb_size_du_value_minus1[ bsIdx ] + 1 ) * 2(4 + cpb_size_du_scale)
          cpbSizePu = ( cpb_size_value_minus1[ bsIdx ] + 1 ) * 2(4 + cpb_size_scale)
          BpBitRate[ h ][ i ][ t ][ j ][ k ] = SubPicHrdFlag ? brDu : brPu
          BpbSize[ h ][ i ][ t ][ j ][ k ] = SubPicHrdFlag ? cpbSizeDu : cpbSizePu
        }

```

(F-40)

where the syntax elements `bit_rate_scale`, `cpb_size_du_scale`, and `cpb_size_scale` values are found in the `hrd_parameters()` syntax structure corresponding to the index `bsp_hrd_idx[h][i][t][j][k]`, and the syntax elements `bit_rate_du_value_minus1[bsIdx]`, `bit_rate_value_minus1[bsIdx]`, `cpb_size_du_value_minus1[bsIdx]`, and `cpb_size_value_minus1[bsIdx]` are found in the `sub_layer_hrd_parameters(t)` syntax structure within that `hrd_parameters()` syntax structure.

F.7.4.3.2 Sequence parameter set RBSP semantics

F.7.4.3.2.1 General sequence parameter set RBSP semantics

The specifications in 7.4.3.2.1 apply with following additions and modifications.

sps_max_sub_layers_minus1 plus 1 specifies the maximum number of temporal sub-layers that may be present in each CVS referring to the SPS. The value of `sps_max_sub_layers_minus1` shall be in the range of 0 to 6, inclusive. The value of `sps_max_sub_layers_minus1` shall be less than or equal to `vps_max_sub_layers_minus1`. When not present, the value of `sps_max_sub_layers_minus1` is inferred to be equal to $(\text{sps_ext_or_max_sub_layers_minus1} = 7) ? \text{vps_max_sub_layers_minus1} : \text{sps_ext_or_max_sub_layers_minus1}$.

sps_ext_or_max_sub_layers_minus1 is used to infer the value of `sps_max_sub_layers_minus1` and to derive the value of `MultiLayerExtSpsFlag`.

It is a requirement of bitstream conformance that the following apply:

- If the SPS is referred to by any current picture that belongs to an independent non-base layer, the value of MultiLayerExtSpsFlag derived from the SPS shall be equal to 0.
- Otherwise, the value of MultiLayerExtSpsFlag derived from the SPS shall be equal to 1.

sps_temporal_id_nesting_flag, when `sps_max_sub_layers_minus1` is greater than 0, specifies whether inter prediction is additionally restricted for CVSs referring to the SPS. When `vps_temporal_id_nesting_flag` is equal to 1, `sps_temporal_id_nesting_flag` shall be equal to 1. When `sps_max_sub_layers_minus1` is equal to 0, `sps_temporal_id_nesting_flag` shall be equal to 1. When not present, the value of `sps_temporal_id_nesting_flag` is inferred as follows:

- If `sps_max_sub_layers_minus1` is greater than 0, the value of `sps_temporal_id_nesting_flag` is inferred to be equal to `vps_temporal_id_nesting_flag`.
- Otherwise, the value of `sps_temporal_id_nesting_flag` is inferred to be equal to 1.

NOTE 1 The syntax element `sps_temporal_id_nesting_flag` is used to indicate that temporal up-switching, i.e. switching from decoding up to any TemporalId tldN to decoding up to any TemporalId tldM that is greater than tldN, is always possible in the CVS.

update_rep_format_flag equal to 1 specifies that `sps_rep_format_idx` is present and that the `sps_rep_format_idx`-th `rep_format()` syntax structures in the active VPS applies to the layers that refer to this SPS. `update_rep_format_flag` equal to 0 specifies that `sps_rep_format_idx` is not present. When the value of `vps_num_rep_formats_minus1` in the active VPS is equal to 0, it is a requirement of bitstream conformance that the value of `update_rep_format_flag` shall be equal to 0. When not present, the value of `update_rep_format_flag` is inferred to be equal to 0.

sps_rep_format_idx specifies the index, into the list of `rep_format()` syntax structures in the VPS, of the `rep_format()` syntax structure that applies to the layers that refer to this SPS. The value of `sps_rep_format_idx` shall be in the range of 0 to `vps_num_rep_formats_minus1`, inclusive.

When a current picture with `nuh_layer_id` `layerIdCurr` greater than 0 refers to an SPS and the layer with `nuh_layer_id` equal to `layerIdCurr` is not an independent non-base layer, the values of `chroma_format_idc`, `separate_colour_plane_flag`, `pic_width_in_luma_samples`, `pic_height_in_luma_samples`, `bit_depth_luma_minus8`, `bit_depth_chroma_minus8`, `conf_win_left_offset`, `conf_win_right_offset`, `conf_win_top_offset`, and `conf_win_bottom_offset` are inferred or constrained as follows:

- The variable `repFormatIdx` is derived as follows:
 - If `update_rep_format_flag` is equal to 0, the variable `repFormatIdx` is set equal to `vps_rep_format_idx[LayerIdxInVps[layerIdCurr]]`.
 - Otherwise (`update_rep_format_flag` is equal to 1), `repFormatIdx` is set equal to `sps_rep_format_idx`.
- If `MultiLayerExtSpsFlag` derived from the active SPS for the layer with `nuh_layer_id` equal to `layerIdCurr` is equal to 0, the values of `chroma_format_idc`, `separate_colour_plane_flag`, `pic_width_in_luma_samples`, `pic_height_in_luma_samples`, `bit_depth_luma_minus8`, `bit_depth_chroma_minus8`, `conf_win_left_offset`, `conf_win_right_offset`, `conf_win_top_offset`, and `conf_win_bottom_offset`, are inferred to be equal to `chroma_format_vps_idc`, `separate_colour_plane_vps_flag`, `pic_width_vps_in_luma_samples`, `pic_height_vps_in_luma_samples`, `bit_depth_vps_luma_minus8`, `bit_depth_vps_chroma_minus8`, `conf_win_vps_left_offset`, `conf_win_vps_right_offset`, `conf_win_vps_top_offset`, and `conf_win_vps_bottom_offset`, respectively, of the `repFormatIdx`-th `rep_format()` syntax structure in the active VPS and the values of `chroma_format_idc`, `separate_colour_plane_flag`, `pic_width_in_luma_samples`,

pic_height_in_luma_samples, bit_depth_luma_minus8, bit_depth_chroma_minus8, conf_win_left_offset, conf_win_right_offset, conf_win_top_offset, and conf_win_bottom_offset signalled in the active SPS for the layer with nuh_layer_id equal to layerIdCurr are ignored.

NOTE 2 The values are inferred from the VPS when a layer that is not an independent layer refers to an SPS that is also referred to by the base layer, in which case the SPS has nuh_layer_id equal to 0. For independent layers, the values of these parameters in the active SPS for the base layer apply.

- Otherwise, the values of chroma_format_idc, separate_colour_plane_flag, pic_width_in_luma_samples, pic_height_in_luma_samples, bit_depth_luma_minus8, bit_depth_chroma_minus8, conf_win_left_offset, conf_win_right_offset, conf_win_top_offset, and conf_win_bottom_offset are inferred to be equal to chroma_format_vps_idc, separate_colour_plane_vps_flag, pic_width_vps_in_luma_samples, pic_height_vps_in_luma_samples, bit_depth_vps_luma_minus8, bit_depth_vps_chroma_minus8, conf_win_vps_left_offset, conf_win_vps_right_offset, conf_win_vps_top_offset, and conf_win_vps_bottom_offset respectively, of the repFormatIdx-th rep_format() syntax structure in the active VPS.

It is a requirement of bitstream conformance that, when present, the value of chroma_format_idc, pic_width_in_luma_samples, pic_height_in_luma_samples, bit_depth_luma_minus8, or bit_depth_chroma_minus8 shall be less than or equal to chroma_format_vps_idc, pic_width_vps_in_luma_samples, pic_height_vps_in_luma_samples, bit_depth_vps_luma_minus8, or bit_depth_vps_chroma_minus8, respectively, of the vps_rep_format_idx[j]-th rep_format() syntax structure in the active VPS, where j is equal to LayerIdxInVps[layerIdCurr].

sps_max_dec_pic_buffering_minus1[i] plus 1 specifies the maximum required size of the decoded picture buffer for the CVS in units of picture storage buffers when HighestTid is equal to i. The value of sps_max_dec_pic_buffering_minus1[i] shall be in the range of 0 to MaxDpbSize – 1, inclusive, where MaxDpbSize is as specified in A.4. When i is greater than 0, sps_max_dec_pic_buffering_minus1[i] shall be greater than or equal to sps_max_dec_pic_buffering_minus1[i – 1]. The value of sps_max_dec_pic_buffering_minus1[i] shall be less than or equal to vps_max_dec_pic_buffering_minus1[i] for each value of i. When sps_max_dec_pic_buffering_minus1[i] is not present for i in the range of 0 to sps_max_sub_layers_minus1 – 1, inclusive, due to sps_sub_layer_ordering_info_present_flag being equal to 0, it is inferred to be equal to sps_max_dec_pic_buffering_minus1[sps_max_sub_layers_minus1].

When sps_max_dec_pic_buffering_minus1[i] is not present for i in the range of 0 to sps_max_sub_layers_minus1, inclusive, due to MultiLayerExtSpsFlag being equal to 1, for a layer that refers to the SPS and has nuh_layer_id equal to currLayerId, the value of sps_max_dec_pic_buffering_minus1[i] is inferred to be equal to max_vps_dec_pic_buffering_minus1[TargetOlsIdx][layerIdx][i] of the active VPS, where layerIdx is equal to the value such that LayerSetLayerIdList[TargetDecLayerSetIdx][layerIdx] is equal to currLayerId.

sps_infer_scaling_list_flag equal to 1 specifies that the syntax elements of the scaling list data syntax structure of the SPS are inferred to be equal to those of the SPS that is active for the layer with nuh_layer_id equal to sps_scaling_list_ref_layer_id. sps_infer_scaling_list_flag equal to 0 specifies that the syntax elements of the scaling list data syntax structure are not inferred. When not present, the value of sps_infer_scaling_list_flag is inferred to be 0.

sps_scaling_list_ref_layer_id specifies the value of the nuh_layer_id of the layer for which the active SPS is associated with the same scaling list data as the current SPS. The value of sps_scaling_list_ref_layer_id shall be in the range of 0 to 62, inclusive.

When vps_base_layer_internal_flag is equal to 0, it is a requirement of bitstream conformance that the value of sps_scaling_list_ref_layer_id, when present, shall be greater than 0.

It is a requirement of bitstream conformance that, when an SPS with nuh_layer_id equal to nuhLayerIdA is active for a layer with nuh_layer_id equal to nuhLayerIdB and sps_infer_scaling_list_flag in the SPS is

equal to 1, `sps_infer_scaling_list_flag` shall be equal to 0 for the SPS that is active for the layer with `nuh_layer_id` equal to `sps_scaling_list_ref_layer_id`.

It is a requirement of bitstream conformance that, when an SPS with `nuh_layer_id` equal to `nuhLayerIdA` is active for a layer with `nuh_layer_id` equal to `nuhLayerIdB` and `sps_infer_scaling_list_flag` in the SPS equal to 1, the layer with `nuh_layer_id` equal to `sps_scaling_list_ref_layer_id` shall be a reference layer of the layer with `nuh_layer_id` equal to `nuhLayerIdB`.

It is a requirement of bitstream conformance that, when an SPS is active for a layer with `sps_infer_scaling_list_flag` in the SPS is equal to 1, `scaling_list_enabled_flag` shall be equal to 1 for the SPS that is active for the layer with `nuh_layer_id` equal to `sps_scaling_list_ref_layer_id`.

F.7.4.3.2.2 Sequence parameter set range extension semantics

The specifications in 7.4.3.2.2 apply.

F.7.4.3.2.3 Sequence parameter set screen content coding extension semantics

The specifications in 7.4.3.2.3 apply.

F.7.4.3.2.4 Sequence parameter set multilayer extension semantics

`inter_view_mv_vert_constraint_flag` equal to 1 indicates that vertical component of motion vectors used for inter-layer prediction are constrained in the layers for which this SPS RBSP is the active SPS RBSP. When `inter_view_mv_vert_constraint_flag` is equal to 1, the vertical component of the motion vectors used for inter-layer prediction shall be equal to or less than 56 in units of luma samples. When `inter_view_mv_vert_constraint_flag` is equal to 0, no constraint on the vertical component of the motion vectors used for inter-layer prediction is signalled by this flag. When not present, the value of `inter_view_mv_vert_constraint_flag` is inferred to be equal to 0.

F.7.4.3.3 Picture parameter set RBSP semantics

F.7.4.3.3.1 General picture parameter set RBSP semantics

The specifications in 7.4.3.3.1 apply with the replacement of the semantics of `pps_scaling_list_data_present_flag` as follows.

`pps_scaling_list_data_present_flag` equal to 1 specifies that the scaling list data used for the pictures referring to the PPS are derived based on the scaling lists specified by the active SPS and the scaling lists specified by the PPS. `pps_scaling_list_data_present_flag` equal to 0 specifies that the scaling list data used for the pictures referring to the PPS are inferred to be equal to those specified by the active SPS (when `pps_infer_scaling_list_flag` is equal to 0) or is specified by `pps_scaling_list_ref_layer_id` (when `pps_infer_scaling_list_flag` is equal to 1). When `scaling_list_enabled_flag` is equal to 0, the value of `pps_scaling_list_data_present_flag` shall be equal to 0. When `scaling_list_enabled_flag` is equal to 1, `sps_scaling_list_data_present_flag` is equal to 0, `pps_scaling_list_data_present_flag` is equal to 0, and `pps_infer_scaling_list_flag` is equal to 0, the default scaling list data are used to derive the array `ScalingFactor` as specified in 7.4.5.

F.7.4.3.3.2 Picture parameter set range extension semantics

The specifications in 7.4.3.3.2 apply.

F.7.4.3.3.3 Picture parameter set screen content coding extension semantics

The specifications in 7.4.3.3.3 apply.

F.7.4.3.3.4 Picture parameter set multilayer extension semantics

`poc_reset_info_present_flag` equal to 0 specifies that the syntax element `poc_reset_idc` is not present in the slice segment headers of the slices referring to the PPS. `poc_reset_info_present_flag` equal to 1

specifies that the syntax element `poc_reset_idc` is present in the slice segment headers of the slices referring to the PPS. When not present, the value of `poc_reset_info_present_flag` is inferred to be equal to 0.

pps_infer_scaling_list_flag equal to 1 specifies that the syntax elements of the scaling list data syntax structure of the PPS are inferred to be equal to those of the PPS that is active for the layer with `nuh_layer_id` equal to `pps_scaling_list_ref_layer_id`. `pps_infer_scaling_list_flag` equal to 0 specifies that the syntax elements of the scaling list data syntax structure of the PPS are not inferred. When `scaling_list_enabled_flag` is equal to 0, `nuh_layer_id` of the layer referring to the PPS is equal to 0, or `pps_scaling_list_data_present_flag` is equal to 1, `pps_infer_scaling_list_flag` shall be equal to 0. When not present, the value of `pps_infer_scaling_list_flag` is inferred to be 0.

pps_scaling_list_ref_layer_id specifies the value of `nuh_layer_id` of the layer for which the active PPS has the same scaling list data as the current PPS.

The value of `pps_scaling_list_ref_layer_id` shall be in the range of 0 to 62, inclusive.

When `vps_base_layer_internal_flag` is equal to 0, it is a requirement of bitstream conformance that `pps_scaling_list_ref_layer_id`, when present, shall be greater than 0. It is a requirement of bitstream conformance that, when a PPS with `nuh_layer_id` equal to `nuhLayerIdA` is active for a layer with `nuh_layer_id` equal to `nuhLayerIdB` and `pps_infer_scaling_list_flag` in the PPS is equal to 1, `pps_infer_scaling_list_flag` shall be equal to 0 for the PPS that is active for the layer with `nuh_layer_id` equal to `pps_scaling_list_ref_layer_id`.

It is a requirement of bitstream conformance that, when a PPS with `nuh_layer_id` equal to `nuhLayerIdA` is active for a layer with `nuh_layer_id` equal to `nuhLayerIdB` and `pps_infer_scaling_list_flag` in the PPS equal to 1, the layer with `nuh_layer_id` equal to `pps_scaling_list_ref_layer_id` shall be a reference layer of the layer with `nuh_layer_id` equal to `nuhLayerIdB`.

It is a requirement of bitstream conformance that, when a PPS is active for a layer with `pps_infer_scaling_list_flag` in the PPS equal to 1, `scaling_list_enabled_flag` shall be equal to 1 for the SPS that is active for the layer with `nuh_layer_id` equal to `pps_scaling_list_ref_layer_id`.

num_ref_loc_offsets specifies the number of reference layer location offsets that are present in the PPS. The value of `num_ref_loc_offsets` shall be in the range of 0 to `vps_max_layers_minus1`, inclusive.

ref_loc_offset_layer_id[i] specifies the `nuh_layer_id` value for which the *i*-th reference layer location offset parameters are specified.

NOTE `ref_loc_offset_layer_id[i]` need not be among the direct reference layers, for example when the spatial correspondence of an auxiliary picture to its associated primary picture is specified.

The *i*-th reference layer location offset parameters consist of the *i*-th scaled reference layer offset parameters, the *i*-th reference region offset parameters, and the *i*-th resampling phase set parameters.

scaled_ref_layer_offset_present_flag[i] equal to 1 specifies that the *i*-th scaled reference layer offset parameters are present in the PPS. `scaled_ref_layer_offset_present_flag[i]` equal to 0 specifies that the *i*-th scaled reference layer offset parameters are not present in the PPS. When not present, the value of `scaled_ref_layer_offset_present_flag[i]` is inferred to be equal to 0.

The *i*-th scaled reference layer offset parameters specify the spatial correspondence of a picture referring to this PPS relative to the reference region in a decoded picture with `nuh_layer_id` equal to `ref_loc_offset_layer_id[i]`.

scaled_ref_layer_left_offset[ref_loc_offset_layer_id[i]] specifies the horizontal offset between the sample in the current picture that is collocated with the top-left luma sample of the reference region in a decoded picture with `nuh_layer_id` equal to `ref_loc_offset_layer_id[i]` and the top-left luma sample of

the current picture in units of subWC luma samples, where subWC is equal to the SubWidthC of the picture that refers to this PPS. The value of `scaled_ref_layer_left_offset[ref_loc_offset_layer_id[i]]` shall be in the range of -2^{14} to $2^{14} - 1$, inclusive. When not present, the value of `scaled_ref_layer_left_offset[ref_loc_offset_layer_id[i]]` is inferred to be equal to 0.

scaled_ref_layer_top_offset[ref_loc_offset_layer_id[i]] specifies the vertical offset between the sample in the current picture that is collocated with the top-left luma sample of the reference region in a decoded picture with nuh_layer_id equal to ref_loc_offset_layer_id[i] and the top-left luma sample of the current picture in units of subHC luma samples, where subHC is equal to the SubHeightC of the picture that refers to this PPS. The value of `scaled_ref_layer_top_offset[ref_loc_offset_layer_id[i]]` shall be in the range of -2^{14} to $2^{14} - 1$, inclusive. When not present, the value of `scaled_ref_layer_top_offset[ref_loc_offset_layer_id[i]]` is inferred to be equal to 0.

scaled_ref_layer_right_offset[ref_loc_offset_layer_id[i]] specifies the horizontal offset between the sample in the current picture that is collocated with the bottom-right luma sample of the reference region in a decoded picture with nuh_layer_id equal to ref_loc_offset_layer_id[i] and the bottom-right luma sample of the current picture in units of subWC luma samples, where subWC is equal to the SubWidthC of the picture that refers to this PPS. The value of `scaled_ref_layer_right_offset[ref_loc_offset_layer_id[i]]` shall be in the range of -2^{14} to $2^{14} - 1$, inclusive. When not present, the value of `scaled_ref_layer_right_offset[ref_loc_offset_layer_id[i]]` is inferred to be equal to 0.

scaled_ref_layer_bottom_offset[ref_loc_offset_layer_id[i]] specifies the vertical offset between the sample in the current picture that is collocated with the bottom-right luma sample of the reference region in a decoded picture with nuh_layer_id equal to ref_loc_offset_layer_id[i] and the bottom-right luma sample of the current picture in units of subHC luma samples, where subHC is equal to the SubHeightC of the picture that refers to this PPS. The value of `scaled_ref_layer_bottom_offset[ref_loc_offset_layer_id[i]]` shall be in the range of -2^{14} to $2^{14} - 1$, inclusive. When not present, the value of `scaled_ref_layer_bottom_offset[ref_loc_offset_layer_id[i]]` is inferred to be equal to 0.

Let `currTopLeftSample`, `currBotRightSample`, `colRefRegionTopLeftSample`, and `colRefRegionBotRightSample` be the top-left luma sample of the current picture, the bottom-right luma sample of the current picture, the sample in the current picture that is collocated with the top-left luma sample of the reference region in a decoded picture with nuh_layer_id equal to `ref_loc_offset_layer_id[i]`, and the sample in the current picture that is collocated with the bottom-right luma sample of the reference region in the decoded picture with nuh_layer_id equal to `ref_loc_offset_layer_id[i]`, respectively.

When the value of `scaled_ref_layer_left_offset[ref_loc_offset_layer_id[i]]` is greater than 0, `colRefRegionTopLeftSample` is located to the right of `currTopLeftSample`. When the value of `scaled_ref_layer_left_offset[ref_loc_offset_layer_id[i]]` is less than 0, `colRefRegionTopLeftSample` is located to the left of `currTopLeftSample`.

When the value of `scaled_ref_layer_top_offset[ref_loc_offset_layer_id[i]]` is greater than 0, `colRefRegionTopLeftSample` is located below `currTopLeftSample`. When the value of `scaled_ref_layer_top_offset[ref_loc_offset_layer_id[i]]` is less than 0, `colRefRegionTopLeftSample` is located above `currTopLeftSample`.

When the value of `scaled_ref_layer_right_offset[ref_loc_offset_layer_id[i]]` is greater than 0, `colRefRegionBotRightSample` is located to the left of `currBotRightSample`. When the value of `scaled_ref_layer_right_offset[ref_loc_offset_layer_id[i]]` is less than 0, `colRefRegionTopLeftSample` is located to the right of `currBotRightSample`.

When the value of `scaled_ref_layer_bottom_offset[ref_loc_offset_layer_id[i]]` is greater than 0, `colRefRegionBotRightSample` is located above `currBotRightSample`. When the value of

scaled_ref_layer_bottom_offset[ref_loc_offset_layer_id[i]] is less than 0, colRefRegionTopLeftSample is located below currBotRightSample.

ref_region_offset_present_flag[i] equal to 1 specifies that the *i*-th reference region offset parameters are present in the PPS. **ref_region_offset_present_flag[i]** equal to 0 specifies that the *i*-th reference region offset parameters are not present in the PPS. When not present, the value of **ref_region_offset_present_flag[i]** is inferred to be equal to 0.

The *i*-th reference region offset parameters specify the spatial correspondence of the reference region in the decoded picture with nuh_layer_id equal to ref_loc_offset_layer_id[*i*] relative to the same decoded picture.

ref_region_left_offset[ref_loc_offset_layer_id[i]] specifies the horizontal offset between the top-left luma sample of the reference region in the decoded picture with nuh_layer_id equal to ref_loc_offset_layer_id[*i*] and the top-left luma sample of the same decoded picture in units of subWC luma samples, where subWC is equal to the SubWidthC of the layer with nuh_layer_id equal to ref_loc_offset_layer_id[*i*]. The value of **ref_region_left_offset[ref_loc_offset_layer_id[i]]** shall be in the range of -2^{14} to $2^{14} - 1$, inclusive. When not present, the value of **ref_region_left_offset[ref_loc_offset_layer_id[i]]** is inferred to be equal to 0.

ref_region_top_offset[ref_loc_offset_layer_id[i]] specifies the vertical offset between the top-left luma sample of the reference region in the decoded picture with nuh_layer_id equal to ref_loc_offset_layer_id[*i*] and the top-left luma sample of the same decoded picture in units of subHC luma samples, where subHC is equal to the SubHeightC of the layer with nuh_layer_id equal to ref_loc_offset_layer_id[*i*]. The value of **ref_region_top_offset[ref_loc_offset_layer_id[i]]** shall be in the range of -2^{14} to $2^{14} - 1$, inclusive. When not present, the value of **ref_region_top_offset[ref_loc_offset_layer_id[i]]** is inferred to be equal to 0.

ref_region_right_offset[ref_loc_offset_layer_id[i]] specifies the horizontal offset between the bottom-right luma sample of the reference region in the decoded picture with nuh_layer_id equal to ref_loc_offset_layer_id[*i*] and the bottom-right luma sample of the same decoded picture in units of subWC luma samples, where subWC is equal to the SubWidthC of the layer with nuh_layer_id equal to ref_loc_offset_layer_id[*i*]. The value of **ref_region_right_offset[ref_loc_offset_layer_id[i]]** shall be in the range of -2^{14} to $2^{14} - 1$, inclusive. When not present, the value of **ref_region_right_offset[ref_loc_offset_layer_id[i]]** is inferred to be equal to 0.

ref_region_bottom_offset[ref_loc_offset_layer_id[i]] specifies the vertical offset between the bottom-right luma sample of the reference region in the decoded picture with nuh_layer_id equal to ref_loc_offset_layer_id[*i*] and the bottom-right luma sample of the same decoded picture in units of subHC luma samples, where subHC is equal to the SubHeightC of the layer with nuh_layer_id equal to ref_loc_offset_layer_id[*i*]. The value of **ref_region_bottom_offset[ref_loc_offset_layer_id[i]]** shall be in the range of -2^{14} to $2^{14} - 1$, inclusive. When not present, the value of **ref_region_bottom_offset[ref_loc_offset_layer_id[i]]** is inferred to be equal to 0.

Let refPicTopLeftSample, refPicBotRightSample, refRegionTopLeftSample, and refRegionBotRightSample be the top-left luma sample of the decoded picture with nuh_layer_id equal to ref_loc_offset_layer_id[*i*], the bottom-right luma sample of the decoded picture with nuh_layer_id equal to ref_loc_offset_layer_id[*i*], the top-left luma sample of the reference region in the decoded picture with nuh_layer_id equal to ref_loc_offset_layer_id[*i*], and the bottom-right luma sample of the reference region in the decoded picture with nuh_layer_id equal to ref_loc_offset_layer_id[*i*], respectively.

When the value of **ref_region_left_offset[ref_loc_offset_layer_id[i]]** is greater than 0, refRegionTopLeftSample is located to the right of refPicTopLeftSample. When the value of **ref_region_left_offset[ref_loc_offset_layer_id[i]]** is less than 0, refRegionTopLeftSample is located to the left of refPicTopLeftSample.

ISO/IEC 23008-2:2017(E)

When the value of `ref_region_top_offset[ref_loc_offset_layer_id[i]]` is greater than 0, `refRegionTopLeftSample` is located below `refPicTopLeftSample`. When the value of `ref_region_top_offset[ref_loc_offset_layer_id[i]]` is less than 0, `refRegionTopLeftSample` is located above `refPicTopLeftSample`.

When the value of `ref_region_right_offset[ref_loc_offset_layer_id[i]]` is greater than 0, `refRegionBotRightSample` is located to the left of `refPicBotRightSample`. When the value of `ref_region_right_offset[ref_loc_offset_layer_id[i]]` is less than 0, `refRegionBotRightSample` is located to the right of `refPicBotRightSample`.

When the value of `ref_region_bottom_offset[ref_loc_offset_layer_id[i]]` is greater than 0, `refRegionBotRightSample` is located above `refPicBotRightSample`. When the value of `ref_region_bottom_offset[ref_loc_offset_layer_id[i]]` is less than 0, `refRegionBotRightSample` is located below `refPicBotRightSample`.

resample_phase_set_present_flag[i] equal to 1 specifies that the *i*-th resampling phase set is present in the PPS. **resample_phase_set_present_flag[i]** equal to 0 specifies that the *i*-th resampling phase set is not present in the PPS. When not present, the value of **resample_phase_set_present_flag[i]** is inferred to be equal to 0.

The *i*-th resampling phase set specifies the phase offsets used in resampling process of the direct reference layer picture with `nuh_layer_id` equal to `ref_loc_offset_layer_id[i]`. When the layer specified by `ref_loc_offset_layer_id[i]` is not a direct reference layer of the current layer, the values of the syntax elements `phase_hor_luma[ref_loc_offset_layer_id[i]]`, `phase_ver_luma[ref_loc_offset_layer_id[i]]`, `phase_hor_chroma_plus8[ref_loc_offset_layer_id[i]]` and `phase_ver_chroma_plus8[ref_loc_offset_layer_id[i]]` are unspecified and shall be ignored by decoders.

phase_hor_luma[ref_loc_offset_layer_id[i]] specifies the luma phase shift in the horizontal direction used in the resampling process of the direct reference layer picture with `nuh_layer_id` equal to `ref_loc_offset_layer_id[i]`. The value of **phase_hor_luma[ref_loc_offset_layer_id[i]]** shall be in the range of 0 to 31, inclusive. When not present, the value of **phase_hor_luma[ref_loc_offset_layer_id[i]]** is inferred to be equal to 0.

phase_ver_luma[ref_loc_offset_layer_id[i]] specifies the luma phase shift in the vertical direction used in the resampling of the direct reference layer picture with `nuh_layer_id` equal to `ref_loc_offset_layer_id[i]`. The value of **phase_ver_luma[ref_loc_offset_layer_id[i]]** shall be in the range of 0 to 31, inclusive. When not present, the value of **phase_ver_luma[ref_loc_offset_layer_id[i]]** is inferred to be equal to 0.

phase_hor_chroma_plus8[ref_loc_offset_layer_id[i]] minus 8 specifies the chroma phase shift in the horizontal direction used in the resampling of the direct reference layer picture with `nuh_layer_id` equal to `ref_loc_offset_layer_id[i]`. The value of **phase_hor_chroma_plus8[ref_loc_offset_layer_id[i]]** shall be in the range of 0 to 63, inclusive. When not present, the value of **phase_hor_chroma_plus8[ref_loc_offset_layer_id[i]]** is inferred to be equal to 8.

phase_ver_chroma_plus8[ref_loc_offset_layer_id[i]] minus 8 specifies the chroma phase shift in the vertical direction used in the resampling process of the direct reference layer picture with `nuh_layer_id` equal to `ref_loc_offset_layer_id[i]`. The value of **phase_ver_chroma_plus8[ref_loc_offset_layer_id[i]]** shall be in the range of 0 to 63, inclusive. When not present, the value of **phase_ver_chroma_plus8[ref_loc_offset_layer_id[i]]** is inferred as follows.

- If `chroma_format_idc` is equal to 3 (4:4:4 chroma format), the value of **phase_ver_chroma_plus8[ref_loc_offset_layer_id[i]]** is inferred to be equal to 8.
- Otherwise, the value of **phase_ver_chroma_plus8[ref_loc_offset_layer_id[i]]** is inferred to be equal to $(4 * \text{scaledRefRegHeight} + \text{refRegHeight} / 2) / \text{refRegHeight} + 4$, where the value of

scaledRefRegHeight is equal to the value of ScaledRefRegionHeightInSamplesY derived for the direct reference layer picture with nuh_layer_id equal to ref_loc_offset_layer_id[i] of the picture that refers to this PPS, and the value of refRegHeight is equal to RefLayerRegionHeightInSamplesY derived for the direct reference layer picture with nuh_layer_id equal to ref_loc_offset_layer_id[i] of the picture that refers to this PPS.

colour_mapping_enabled_flag equal to 1 specifies the colour mapping process may be applied to the inter-layer reference pictures for the coded pictures referring to the PPS. colour_mapping_enabled_flag equal to 0 specifies that the colour mapping process is not applied to the inter-layer reference pictures for the coded pictures referring to the PPS. When not present, the value of colour_mapping_enabled_flag is inferred to be equal to 0.

It is a requirement of bitstream conformance that, when pps_pic_parameter_set_id is greater than or equal to 8, colour_mapping_enabled_flag shall be equal to 0.

F.7.4.3.3.5 General colour mapping table semantics

num_cm_ref_layers_minus1 specifies the number of the following cm_ref_layer_id[i] syntax elements. The value of num_cm_ref_layers_minus1 shall be in the range of 0 to 61, inclusive.

cm_ref_layer_id[i] specifies the nuh_layer_id value of the associated direct reference layer picture for which the colour mapping table is specified.

cm_octant_depth specifies the maximal split depth of the colour mapping table. In bitstreams conforming to this version of this document, the value of cm_octant_depth shall be in the range of 0 to 1, inclusive. Other values for cm_octant_depth are reserved for future use by ITU-T | ISO/IEC.

The variable OctantNumC is derived as follows:

$$\text{OctantNumC} = 1 \ll \text{cm_octant_depth} \quad (\text{F-41})$$

cm_y_part_num_log2 specifies the number of partitions of the smallest colour mapping table octant for the luma component. In bitstreams conforming to this version of this document, the value of (cm_y_part_num_log2 + cm_octant_depth) shall be in the range of 0 to 3, inclusive. Other values for (cm_y_part_num_log2 + cm_octant_depth) are reserved for future use by ITU-T | ISO/IEC.

The variables OctantNumY and PartNumY are derived as follows:

$$\text{OctantNumY} = 1 \ll (\text{cm_octant_depth} + \text{cm_y_part_num_log2}) \quad (\text{F-42})$$

$$\text{PartNumY} = 1 \ll \text{cm_y_part_num_log2} \quad (\text{F-43})$$

luma_bit_depth_cm_input_minus8 specifies the sample bit depth of the input luma component of the colour mapping process. The variable BitDepthCmInputY is derived as follows:

$$\text{BitDepthCmInputY} = 8 + \text{luma_bit_depth_cm_input_minus8} \quad (\text{F-44})$$

It is a requirement of bitstream conformance that the value of BitDepthCmInputY shall be equal to the bit depth of the luma component of any reference layer with nuh_layer_id equal to one of the cm_ref_layer_id[i], for all i in the range of 0 to num_cm_ref_layers_minus1, inclusive.

chroma_bit_depth_cm_input_minus8 specifies the sample bit depth of the input chroma components of the colour mapping process. The variable BitDepthCmInputC is derived as follows:

$$\text{BitDepthCmInputC} = 8 + \text{chroma_bit_depth_cm_input_minus8} \quad (\text{F-45})$$

It is a requirement of bitstream conformance that the value of BitDepthCmInputC shall be equal to the bit depth of the chroma components of any reference layer with nuh_layer_id equal to one of the cm_ref_layer_id[i], for all i in the range of 0 to num_cm_ref_layers_minus1, inclusive.

luma_bit_depth_cm_output_minus8 specifies the sample bit depth of the output luma component of the colour mapping process. The variable BitDepthCmOutputY is derived as follows:

$$\text{BitDepthCmOutputY} = 8 + \text{luma_bit_depth_cm_output_minus8} \quad (\text{F-46})$$

It is a requirement of bitstream conformance that the value of BitDepthCmOutputY shall be greater than or equal to BitDepthCmInputY and less than or equal to the bit depth of the luma components of any picture that refers to this PPS.

chroma_bit_depth_cm_output_minus8 specifies the sample bit depth of the output chroma components of the colour mapping process. The variable BitDepthCmOutputC is derived as follows:

$$\text{BitDepthCmOutputC} = 8 + \text{chroma_bit_depth_cm_output_minus8} \quad (\text{F-47})$$

It is a requirement of bitstream conformance that the value of BitDepthCmOutputC shall be greater than or equal to BitDepthCmInputC and less than or equal to the bit depth of the chroma components of any picture that refers to this PPS.

cm_res_quant_bits specifies the number of least significant bits to be added to the colour mapping coefficient residual values res_coeff_q and res_coeff_r.

cm_delta_flc_bits_minus1 specifies the delta value used to derive the number of bits used to code the syntax element res_coeff_r. The variable CMResLSBits is set equal to $\text{Max}(0, (10 + \text{BitDepthCmInputY} - \text{BitDepthCmOutputY} - \text{cm_res_quant_bits} - (\text{cm_delta_flc_bits_minus1} + 1)))$.

cm_adapt_threshold_u_delta specifies the partitioning threshold of the Cb component used in colour mapping process. When not present, the value of cm_adapt_threshold_u_delta is inferred to be equal to 0. The value of cm_adapt_threshold_u_delta shall be in the range of $-2^{\text{BitDepthCmInputC} - 1}$ to $2^{\text{BitDepthCmInputC} - 1} - 1$, inclusive.

The variable CMThreshU is derived as follows:

$$\text{CMThreshU} = \text{cm_adapt_threshold_u_delta} + (1 \ll (\text{BitDepthCmInputC} - 1)) \quad (\text{F-48})$$

cm_adapt_threshold_v_delta specifies the partitioning threshold of the Cr component used in colour mapping process. When not present, the value of cm_adapt_threshold_v_delta is inferred to be equal to 0. The value of cm_adapt_threshold_v_delta shall be in the range of $-2^{\text{BitDepthCmInputC} - 1}$ to $2^{\text{BitDepthCmInputC} - 1} - 1$, inclusive.

The variable CMThreshV is derived as follows:

$$\text{CMThreshV} = \text{cm_adapt_threshold_v_delta} + (1 \ll (\text{BitDepthCmInputC} - 1)) \quad (\text{F-49})$$

F.7.4.3.3.6 Colour mapping octants semantics

split_octant_flag equal to 1 specifies that the current colour mapping octant is further split into eight octants with half length in each of the three dimensions. split_octant_flag equal to 0 specifies that the current colour mapping octant is not further split into eight octants. When not present, the value of split_octant_flag is inferred to be equal to 0.

coded_res_flag[idxShiftY][idxCb][idxCr][j] equal to 1 specifies that the residuals for the j-th colour mapping coefficients of the octant with octant index equal to (idxShiftY, idxCb, idxCr) are present. coded_res_flag[idxShiftY][idxCb][idxCr][j] equal to 0 specifies that the residuals for the j-th colour mapping coefficients of the octant with octant index equal to (idxShiftY, idxCb, idxCr) are not present. When not present, the value of coded_res_flag[idxShiftY][idxCb][idxCr][j] is inferred to be equal to 0.

res_coeff_q[idxShiftY][idxCb][idxCr][j][c] specifies the quotient of the residual for the j-th colour mapping coefficient of the c-th colour component of the octant with octant index equal to (idxShiftY, idxCb, idxCr). When not present, the value of res_coeff_q[idxShiftY][idxCb][idxCr][j][c] is inferred to be equal to 0.

res_coeff_r[idxShiftY][idxCb][idxCr][j][c] specifies the remainder of the residual for the j-th colour mapping coefficient of the c-th colour component of the octant with octant index equal to

(idxShiftY, idxCb, idxCr). The number of bits used to code res_coeff_r is equal to CMResLSBits. If CMResLSBits is equal to 0, res_coeff_r is not present. When not present, the value of res_coeff_r[idxShiftY][idxCb][idxCr][j][c] is inferred to be equal to 0.

res_coeff_s[idxShiftY][idxCb][idxCr][j][c] specifies the sign of the residual for the j-th colour mapping coefficient of the c-th colour component of the octant with octant index equal to (idxShiftY, idxCb, idxCr). When not present, the value of res_coeff_s[idxShiftY][idxCb][idxCr][j][c] is inferred to be equal to 0.

The variables cmResCoeff[idxShiftY][idxCb][idxCr][j][c], with idxShiftY in the range of 0 to OctantNumY - 1, inclusive, idxCb and idxCr both in the range of 0 to OctantNumC - 1, inclusive, j in the range of 0 to 3, inclusive, and c in the range of 0 to 2, inclusive, are derived as follows:

$$\begin{aligned} \text{cmResCoeff}[\text{idxShiftY}][\text{idxCb}][\text{idxCr}][j][c] = & \\ & (1 - 2 * \text{res_coeff_s}[\text{idxShiftY}][\text{idxCb}][\text{idxCr}][j][c]) * \\ & ((\text{res_coeff_q}[\text{idxShiftY}][\text{idxCb}][\text{idxCr}][j][c] \ll \text{CMResLSBits}) + \text{res_coeff_r}[\text{idxShiftY}][\text{idxCb}][\text{idxCr}][j][c]) \ll \text{cm_res_quant_bits} \end{aligned} \quad (\text{F-50})$$

The colour mapping coefficients LutY[idxY][idxCb][idxCr][j], LutCb[idxY][idxCb][idxCr][j], LutCr[idxY][idxCb][idxCr][j] with idxY in the range of 0 and OctantNumY - 1, inclusive, idxCb in the range of 0 and OctantNumC - 1, inclusive, idxCr in the range of 0 and OctantNumC - 1, inclusive, and j in the range of 0 and 3, inclusive, are derived as follows:

```

if( idxY == 0 ) {
    predY[ idxY ][ idxCb ][ idxCr ][ j ] = ( j == 0 ) ? 1024 : 0
    predCb[ idxY ][ idxCb ][ idxCr ][ j ] = ( j == 1 ) ? 1024 : 0
    predCr[ idxY ][ idxCb ][ idxCr ][ j ] = ( j == 2 ) ? 1024 : 0
} else {
    predY[ idxY ][ idxCb ][ idxCr ][ j ] = LutY[ idxY - 1 ][ idxCb ][ idxCr ][ j ]
    predCb[ idxY ][ idxCb ][ idxCr ][ j ] = LutCb[ idxY - 1 ][ idxCb ][ idxCr ][ j ]
    predCr[ idxY ][ idxCb ][ idxCr ][ j ] = LutCr[ idxY - 1 ][ idxCb ][ idxCr ][ j ]
}
LutY[ idxY ][ idxCb ][ idxCr ][ j ] =
    ( cmResCoeff[ idxY ][ idxCb ][ idxCr ][ j ][ 0 ] ) +
    predY[ idxY ][ idxCb ][ idxCr ][ j ]
LutCb[ idxY ][ idxCb ][ idxCr ][ j ] =
    ( cmResCoeff[ idxY ][ idxCb ][ idxCr ][ j ][ 1 ] ) +
    predCb[ idxY ][ idxCb ][ idxCr ][ j ]
LutCr[ idxY ][ idxCb ][ idxCr ][ j ] =
    ( cmResCoeff[ idxY ][ idxCb ][ idxCr ][ j ][ 2 ] ) +
    predCr[ idxY ][ idxCb ][ idxCr ][ j ]
    
```

(F-51)

It is a requirement of bitstream conformance that the values of LutY[idxY][idxCb][idxCr][i], LutCb[idxY][idxCb][idxCr][i], and LutCr[idxY][idxCb][idxCr][i] shall be in the range of -2¹¹ to 2¹¹ - 1, inclusive.

NOTE When BitDepthCmInputC is not equal to BitDepthCmInputY, the encoder is expected to select values of LutY[idxY][idxCb][idxCr][1], LutY[idxY][idxCb][idxCr][2], LutCb[idxY][idxCb][idxCr][0] and LutCr[idxY][idxCb][idxCr][0] that compensate for the bit depth difference.

F.7.4.3.4 Supplemental enhancement information RBSP semantics

The specifications in 7.4.3.4 apply.

F.7.4.3.5 Access unit delimiter RBSP semantics

The specifications in 7.4.3.5 apply.

ISO/IEC 23008-2:2017(E)

F.7.4.3.6 End of sequence RBSP semantics

The specifications in 7.4.3.6 apply with the following additions.

When included in a NAL unit with `nuh_layer_id` `nuhLayerId`, the end of sequence RBSP specifies that the next picture having `nuh_layer_id` equal to `nuhLayerId` or `IdPredictedLayer[nuhLayerId][i]` for any value of `i` in the range of 0 to `NumPredictedLayers[nuhLayerId] - 1`, inclusive, following the current access unit in the bitstream in decoding order (if any) is an IRAP picture with `NoRaslOutputFlag` equal to 1 and with `nuh_layer_id` equal to `nuhLayerId`.

F.7.4.3.7 End of bitstream RBSP semantics

The specifications in 7.4.3.7 apply.

F.7.4.3.8 Filler data RBSP semantics

The specifications in 7.4.3.8 apply.

F.7.4.3.9 Slice segment layer RBSP semantics

The specifications in 7.4.3.9 apply.

F.7.4.3.10 RBSP slice segment trailing bits semantics

The specifications in 7.4.3.10 apply.

F.7.4.3.11 RBSP trailing bits semantics

The specifications in 7.4.3.11 apply.

F.7.4.3.12 Byte alignment semantics

The specifications in 7.4.3.12 apply.

F.7.4.4 Profile, tier, and level semantics

The specifications in 7.4.4 apply with the replacement of each reference to “Annex A” with a reference to “Annex A, G.11, or H.11” and with the following additions and modifications.

The variable `offsetVal` is set equal to 0 and the variable `VpsProfileTierLevel[i]` is derived according to the following ordered steps:

1. `VpsProfileTierLevel[0]` is set equal to the `profile_tier_level()` syntax structure in the base VPS (i.e. in the VPS but not in the VPS extension syntax structure `vps_extension()`), and `offsetVal` is set equal to 1.
2. When `vps_max_layers_minus1` is greater than 0 and `vps_base_layer_internal_flag` is equal to 1, `VpsProfileTierLevel[offsetVal]` is set equal to the first `profile_tier_level()` syntax structure in the VPS extension, and `offsetVal` is incremented by 1.
3. For `j` in the range of 0 to $(\text{vps_num_profile_tier_level_minus1} - (\text{vps_base_layer_internal_flag} ? 2 : 1))$, inclusive, `VpsProfileTierLevel[offsetVal + j]` is set equal to the `j`-th `profile_tier_level()` syntax structure signalled after the syntax element `vps_num_profile_tier_level_minus1` in the VPS extension.

If `vps_base_layer_internal_flag` is equal to 0, all bits in the `profile_tier_level()` syntax structure `VpsProfileTierLevel[0]` shall be equal to 0 and decoders shall ignore the syntax structure

VpsProfileTierLevel[0]. Otherwise, the semantics of the profile_tier_level() syntax structure VpsProfileTierLevel[0] are specified by the remaining part of the current clause.

The scope to which the profile_tier_level() syntax structure applies is specified as follows:

- If the profile_tier_level() syntax structure is included in an active SPS for the base layer or is the profile_tier_level() syntax structure VpsProfileTierLevel[0], it applies to the OLS containing all layers in the bitstream but with only the base layer being the output layer.
- Otherwise, if the profile_tier_level() syntax structure is included in an active SPS for an independent non-base layer with nuh_layer_id equal to layerId, it applies to the output bitstream of the independent non-base layer rewriting process of F.10.2 with the input variables assignedBaseLayerId equal to layerId and tldTarget equal to 6.
- Otherwise, if all of the following conditions are true, the profile_tier_level() syntax structure VpsProfileTierLevel[profile_tier_level_idx[olsIdx][0]] applies to the output bitstream of the independent non-base layer rewriting process of F.10.2 with the input variables assignedBaseLayerId equal to LayerSetLayerIdList[OlsIdxToLsIdx[olsIdx][0]] and tldTarget equal to 6:
 - num_add_layer_sets is greater than 0.
 - OlsIdxToLsIdx[olsIdx] is in the range of FirstAddLayerSetIdx to LastAddLayerSetIdx, inclusive.
 - NumLayersInIdList[OlsIdxToLsIdx[olsIdx]] is equal to 1.
 - The profile_tier_level() syntax structure VpsProfileTierLevel[profile_tier_level_idx[olsIdx][0]] indicates a profile specified in Annex A.
 - The value of general_inbld_flag in the profile_tier_level() syntax structure VpsProfileTierLevel[profile_tier_level_idx[olsIdx][0]] is equal to 1.
- Otherwise, the profile_tier_level() syntax structure provides profile, tier, and level to which a layer in an OLS conforms and the profile_tier_level_idx[i][j] syntax element specifies that the profile_tier_level() syntax structure VpsProfileTierLevel[profile_tier_level_idx[i][j]] applies to the j-th layer of the i-th OLS.

NOTE 1 When vps_base_layer_internal_flag is equal to 1 and vps_max_layers_minus1 is greater than 0, the value of profile_tier_level_idx[0][0] is inferred to be equal to 1, such that VpsProfileTierLevel[1] applies to the 0-th OLS, which contains only the base layer that is the only output layer.

When the profile_tier_level() syntax structure is VpsProfileTierLevel[k] for k greater than 0 and profilePresentFlag is equal to 0, the syntax elements general_profile_space, general_tier_flag, general_profile_idc, general_profile_compatibility_flag[j], general_progressive_source_flag, general_interlaced_source_flag, general_non_packed_constraint_flag, general_frame_only_constraint_flag, general_max_12bit_constraint_flag, general_max_10bit_constraint_flag, general_max_8bit_constraint_flag, general_max_422chroma_constraint_flag, general_max_420chroma_constraint_flag, general_max_monochrome_constraint_flag, general_intra_constraint_flag, general_one_picture_only_constraint_flag, general_lower_bit_rate_constraint_flag, general_max_14bit_constraint_flag, general_reserved_zero_33bits, general_reserved_zero_34bits, general_reserved_zero_43bits, general_inbld_flag, and general_reserved_zero_1bit are not present in the profile_tier_level() syntax structure and each is inferred to be equal to the value of corresponding syntax element of the profile_tier_level() syntax structure VpsProfileTierLevel[k - 1].

When the `profile_tier_level()` syntax structure is `VpsProfileTierLevel[k]` for `k` greater than 0 and any of the syntax elements `sub_layer_profile_space[i]`, `sub_layer_tier_flag[i]`, `sub_layer_profile_idc[i]`, `sub_layer_profile_compatibility_flag[i][j]`, `sub_layer_progressive_source_flag[i]`, `sub_layer_interlaced_source_flag[i]`, `sub_layer_non_packed_constraint_flag[i]`, `sub_layer_frame_only_constraint_flag[i]`, `sub_layer_max_12bit_constraint_flag[i]`, `sub_layer_max_10bit_constraint_flag[i]`, `sub_layer_max_8bit_constraint_flag[i]`, `sub_layer_max_422chroma_constraint_flag[i]`, `sub_layer_max_420chroma_constraint_flag[i]`, `sub_layer_max_monochrome_constraint_flag[i]`, `sub_layer_intra_constraint_flag[i]`, `sub_layer_one_picture_only_constraint_flag[i]`, `sub_layer_lower_bit_rate_constraint_flag[i]`, `sub_layer_max_14bit_constraint_flag[i]`, `sub_layer_reserved_zero_33bits[i]`, `sub_layer_reserved_zero_34bits[i]`, `sub_layer_reserved_zero_43bits[i]`, `sub_layer_inbld_flag[i]`, `sub_layer_reserved_zero_1bit[i]`, and `sub_layer_level_idc[i]` is not present for any value of `i` in the range of 0 to `maxNumSubLayersMinus1 - 1`, inclusive, in the `profile_tier_level()` syntax structure, the value of the syntax element is inferred to be equal to the value of the corresponding syntax element of the `profile_tier_level()` syntax structure `VpsProfileTierLevel[k - 1]`.

A sequence of pictures `picSeq` is derived as follows:

- If the `profile_tier_level()` syntax structure is included in an SPS, `picSeq` consists of the pictures in the CLVS of the layer for which the SPS is the active SPS.
- Otherwise, if the `profile_tier_level()` syntax structure is `VpsProfileTierLevel[0]`, `picSeq` consists of the pictures with `nuh_layer_id` equal to 0 in the CVS.
- Otherwise, if `vps_max_layers_minus1` is greater than 0, `vps_base_layer_internal_flag` is equal to 1, and the `profile_tier_level()` syntax structure is `VpsProfileTierLevel[1]`, `picSeq` consists of the pictures with `nuh_layer_id` equal to 0 in the CVS.
- Otherwise (the `profile_tier_level()` syntax structure is `VpsProfileTierLevel[offsetVal + profile_tier_level_idx[i][j]]` for any values of `i` in the range of 0 to `NumOutputLayerSets - 1`, inclusive, and `j` in the range of 0 to `NumLayersInIdList[OlsIdxToLsIdx[i]] - 1`, inclusive, such that `NecessaryLayerFlag[i][j]` is equal to 1), `picSeq` consists of the pictures with `nuh_layer_id` equal to `LayerSetLayerIdList[OlsIdxToLsIdx[i]][j]` in the CVS.

general_progressive_source_flag and **general_interlaced_source_flag** are interpreted as follows:

- If `general_progressive_source_flag` is equal to 1 and `general_interlaced_source_flag` is equal to 0, the source scan type of the pictures in the `picSeq` should be interpreted as progressive only.
- Otherwise, if `general_progressive_source_flag` is equal to 0 and `general_interlaced_source_flag` is equal to 1, the source scan type of the pictures in the `picSeq` should be interpreted as interlaced only.
- Otherwise, if `general_progressive_source_flag` is equal to 0 and `general_interlaced_source_flag` is equal to 0, the source scan type of the pictures in the `picSeq` should be interpreted as unknown or unspecified.
- Otherwise, `general_progressive_source_flag` is equal to 1 and `general_interlaced_source_flag` is equal to 1, the source scan type of each picture in the `picSeq` is indicated at the picture level using the syntax element `source_scan_type` in a picture timing SEI message or the syntax element `ffinfo_source_scan_type` in a frame-field information SEI message.

NOTE 2 Decoders may ignore the values of `general_progressive_source_flag` and `general_interlaced_source_flag` for purposes other than determining the value to be inferred for `frame_field_info_present_flag` when `vui_parameters_present_flag` is equal to 0, as there are no other decoding process requirements associated with the values of these flags. Moreover, the actual source scan type of the pictures is outside the scope of this

document, and the method by which the encoder selects the values of `general_progressive_source_flag` and `general_interlaced_source_flag` is unspecified.

general_non_packed_constraint_flag equal to 1 specifies that there are neither frame packing arrangement SEI messages nor segmented rectangular frame packing arrangement SEI messages present for the pictures of `picSeq`. `general_non_packed_constraint_flag` equal to 0 indicates that there may or may not be one or more frame packing arrangement SEI messages or segmented rectangular frame packing arrangement SEI messages present for the pictures of `picSeq`.

NOTE 3 Decoders may ignore the value of `general_non_packed_constraint_flag`, as there are no decoding process requirements associated with the presence or interpretation of frame packing arrangement SEI messages or segmented rectangular frame packing arrangement SEI messages.

general_frame_only_constraint_flag equal to 1 specifies that `field_seq_flag` in the active SPSs for the pictures of `picSeq` is equal to 0. `general_frame_only_constraint_flag` equal to 0 indicates that `field_seq_flag` in the active SPSs for the pictures of `picSeq` may or may not be equal to 0.

NOTE 4 Decoders may ignore the value of `general_frame_only_constraint_flag`, as there are no decoding process requirements associated with the value of `field_seq_flag`.

NOTE 5 When `general_progressive_source_flag` is equal to 1, `general_frame_only_constraint_flag` may or may not be equal to 1.

It is a requirement of bitstream conformance that when `olsIdx` is such that `alt_output_layer_flag[olsIdx]` is equal to 1, `general_progressive_source_flag`, `general_interlaced_source_flag`, `general_non_packed_constraint_flag`, and `general_frame_only_constraint_flag` in `VpsProfileTierLevel[offsetVal + profile_tier_level_idx[olsIdx][j]]` shall be equal to `general_progressive_source_flag`, `general_interlaced_source_flag`, `general_non_packed_constraint_flag`, and `general_frame_only_constraint_flag`, respectively, in `VpsProfileTierLevel[offsetVal + profile_tier_level_idx[olsIdx][k]]` for any values of `j` and `k` in the range of 0 to `NumLayersInIdList[OlsIdxToLsIdx[olsIdx]] - 1`, inclusive, such that `NecessaryLayerFlag[olsIdx][j]` is equal to 1 and `NecessaryLayerFlag[olsIdx][k]` is equal to 1.

F.7.4.5 Scaling list data semantics

The specifications in 7.4.5 apply.

F.7.4.6 Supplemental enhancement information message semantics

The specifications in 7.4.6 apply.

F.7.4.7 Slice segment header semantics

F.7.4.7.1 General slice segment header semantics

The specifications in 7.4.7.1 apply with the replacement of references to Annex C with references to F.13 and with the following additions.

When present, the value of the slice segment header syntax elements `discardable_flag`, `cross_layer_bla_flag`, `inter_layer_pred_enabled_flag`, `num_inter_layer_ref_pics_minus1`, `poc_reset_idc`, `poc_reset_period_id`, `full_poc_reset_flag`, `poc_lsb_val`, `poc_msb_cycle_val_present_flag`, and `poc_msb_cycle_val` shall be the same in all slice segment headers of a coded picture. When present, the value of the slice segment header syntax elements `inter_layer_pred_layer_idc[i]` shall be the same in all slice segment headers of a coded picture for each possible value of `i`.

When `nal_unit_type` has a value in the range of `BLA_W_LP` to `RSV_IRAP_VCL23`, inclusive, i.e. the picture is an IRAP picture, and `NumDirectRefLayers[nuh_layer_id]` is equal to 0, and `pps_curr_pic_ref_enabled_flag` is equal to 0, `slice_type` shall be equal to 2.

When `sps_max_dec_pic_buffering_minus1[TemporalId]` is equal to 0 and `NumDirectRefLayers[nuh_layer_id]` is equal to 0, and `pps_curr_pic_ref_enabled_flag` is equal to 0, `slice_type` shall be equal to 2.

discardable_flag equal to 1 specifies that the coded picture is not used as a reference picture for inter prediction and is not used as a source picture for inter-layer prediction in the decoding process of subsequent pictures in decoding order. `discardable_flag` equal to 0 specifies that the coded picture may be used as a reference picture for inter prediction and may be used as a source picture for inter-layer prediction in the decoding process of subsequent pictures in decoding order. When `nal_unit_type` is equal to TRAIL_R, TSA_R, STSA_R, RASL_R or RADL_R, the value of `discardable_flag` shall be equal to 0. When not present, the value of `discardable_flag` is inferred to be equal to 0.

NOTE 1 When a coded picture has `discardable_flag` equal to 1 in its slice headers, the picture may be ignored by decoders without affecting the decoding result of any other picture, in the same layer or a different layer.

cross_layer_bla_flag equal to 1 affects the derivation of `NoClrasOutputFlag` and `LayerResetFlag` as specified in F.8.1.3. `cross_layer_bla_flag` shall be equal to 0 for pictures with `nal_unit_type` not equal to IDR_W_RADL or IDR_N_LP or with `nuh_layer_id nuhLayerId` not equal to any value for which `NumDirectRefLayers[nuhLayerId]` is equal to 0. When not present, the value of `cross_layer_bla_flag` is inferred to be equal to 0.

When `vps_extension_flag` is equal to 1, the sum of `NumNegativePics[CurrRpsIdx]`, `NumPositivePics[CurrRpsIdx]`, `num_long_term_sps`, and `num_long_term_pics` shall be less than or equal to `MaxDpbSize - 1`, where `MaxDpbSize` is as specified in G.11.2 or H.11.2.

NOTE 2 The way that `MaxDpbSize` is specified in G.11.2 is the same as in H.11.2.

inter_layer_pred_enabled_flag equal to 1 specifies that inter-layer prediction may be used in decoding of the current picture. `inter_layer_pred_enabled_flag` equal to 0 specifies that inter-layer prediction is not used in decoding of the current picture.

num_inter_layer_ref_pics_minus1 plus 1 specifies the number of pictures that may be used in decoding of the current picture for inter-layer prediction. The length of the `num_inter_layer_ref_pics_minus1` syntax element is `Ceil(Log2(NumDirectRefLayers[nuh_layer_id]))` bits. The value of `num_inter_layer_ref_pics_minus1` shall be in the range of 0 to `NumDirectRefLayers[nuh_layer_id] - 1`, inclusive.

The variables `numRefLayerPics` and `refLayerPicIdx[j]` are derived as follows:

```
for( i = 0, j = 0; i < NumDirectRefLayers[ nuh_layer_id ]; i++ ) {
    refLayerIdx = LayerIdxInVps[ IdDirectRefLayer[ nuh_layer_id ][ i ] ]
    if( sub_layers vps_max_minus1[ refLayerIdx ] >= TemporalId && ( TemporalId == 0 || (F-52)
        max_tid_minus1_ref_pics_plus1[ refLayerIdx ][ LayerIdxInVps[ nuh_layer_id ] ] > TemporalId ) )
        refLayerPicIdx[ j++ ] = i
    }
numRefLayerPics = j
```

The variable `NumActiveRefLayerPics` is derived as follows:

```
if( nuh_layer_id == 0 || numRefLayerPics == 0 )
    NumActiveRefLayerPics = 0
else if( default_ref_layers_active_flag )
    NumActiveRefLayerPics = numRefLayerPics
else if( !inter_layer_pred_enabled_flag )
    NumActiveRefLayerPics = 0
else if( max_one_active_ref_layer_flag || NumDirectRefLayers[ nuh_layer_id ] == 1 )
    NumActiveRefLayerPics = 1
else
    NumActiveRefLayerPics = num_inter_layer_ref_pics_minus1 + 1
```

All slices of a coded picture shall have the same value of NumActiveRefLayerPics.

inter_layer_pred_layer_idc[*i*] specifies the variable, RefPicLayerId[*i*], representing the nuh_layer_id of the *i*-th picture that may be used by the current picture for inter-layer prediction. The length of the inter_layer_pred_layer_idc[*i*] syntax element is $\text{Ceil}(\text{Log}_2(\text{NumDirectRefLayers}[\text{nuh_layer_id}]))$ bits. The value of inter_layer_pred_layer_idc[*i*] shall be in the range of 0 to NumDirectRefLayers[nuh_layer_id] – 1, inclusive. When *i* is greater than 0, inter_layer_pred_layer_idc[*i*] shall be greater than inter_layer_pred_layer_idc[*i* – 1]. When not present, the value of inter_layer_pred_layer_idc[*i*] is inferred to be equal to refLayerPicIdc[*i*].

The variables RefPicLayerId[*i*] for all values of *i* in the range of 0 to NumActiveRefLayerPics – 1, inclusive, are derived as follows:

```
for( i = 0, j = 0; i < NumActiveRefLayerPics; i++ )
    RefPicLayerId[ i ] = IdDirectRefLayer[ nuh_layer_id ][ inter_layer_pred_layer_idc[ i ] ] (F-54)
```

It is a requirement of bitstream conformance that for each value of *i* in the range of 0 to NumActiveRefLayerPics – 1, inclusive, either of the following two conditions shall be true:

- The value of max_tid_il_ref_pics_plus1[LayerIdxInVps[RefPicLayerId[*i*]]][LayerIdxInVps[nuh_layer_id]] is greater than TemporalId.
- The values of max_tid_il_ref_pics_plus1[LayerIdxInVps[RefPicLayerId[*i*]]][LayerIdxInVps[nuh_layer_id]] and TemporalId are both equal to 0 and the picture in the current access unit with nuh_layer_id equal to RefPicLayerId[*i*] is an IRAP picture.

poc_reset_idc equal to 0 specifies that neither the most significant bits nor the least significant bits of the picture order count value for the current picture are reset. poc_reset_idc equal to 1 specifies that only the most significant bits of the picture order count value for the current picture may be reset. poc_reset_idc equal to 2 specifies that both the most significant bits and the least significant bits of the picture order count value for the current picture may be reset. poc_reset_idc equal to 3 specifies that either only the most significant bits or both the most significant bits and the least significant bits of the picture order count value for the current picture may be reset and additional picture order count information is signalled. When not present, the value of poc_reset_idc is inferred to be equal to 0.

It is a requirement of bitstream conformance that the following constraints apply:

- The value of poc_reset_idc shall not be equal to 1 or 2 for a RASL, RADL, or SLNR picture, or a picture that has TemporalId greater than 0, or a picture that has discardable_flag equal to 1.
- The value of poc_reset_idc of all coded pictures that are present in the bitstream in an access unit shall be the same.
- When the picture in an access unit with nuh_layer_id equal to 0 is an IRAP picture and vps_base_layer_internal_flag is equal to 1 and there is at least one other picture in the same access unit that is not an IRAP picture, the value of poc_reset_idc shall be equal to 1 or 2 for all pictures in the access unit.
- When there is at least one picture that has nuh_layer_id greater than 0 and that is an IDR picture with a particular value of nal_unit_type in an access unit and there is at least one other coded picture that is present in the bitstream in the same access unit with a different value of nal_unit_type, the value of poc_reset_idc shall be equal to 1 or 2 for all pictures in the access unit.
- The value of poc_reset_idc of a CRA or BLA picture shall be less than 3.

ISO/IEC 23008-2:2017(E)

- When the picture with `nuh_layer_id` equal to 0 in an access unit is an IDR picture and `vps_base_layer_internal_flag` is equal to 1 and there is at least one non-IDR picture in the same access unit, the value of `poc_reset_idc` shall be equal to 2 for all pictures in the access unit.
- When the picture with `nuh_layer_id` equal to 0 in an access unit is not an IDR picture and `vps_base_layer_internal_flag` is equal to 1, the value of `poc_reset_idc` shall not be equal to 2 for any picture in the access unit.
- When `poc_lsb_not_present_flag[LayerIdxInVps[nuh_layer_id]]` is equal to 1 and `slice_pic_order_cnt_lsb` is greater than 0, the value of `poc_reset_idc` shall not be equal to 2.

The value of `poc_reset_idc` of an access unit is the value of `poc_reset_idc` of the pictures in the access unit.

NOTE 3 Encoders should be cautious in setting the value of `poc_reset_idc` of pictures when there is a picture of a layer not present in an access unit or there is a picture with `discardable_flag` equal to 1 present in an access unit, to ensure that the derived picture order count values of pictures within an access unit are cross-layer aligned. Basically, such cases should be treated similarly as access units with non-cross-layer-aligned IRAP pictures in terms of whether POC resetting is needed.

NOTE 4 As specified in F.8.3.1, the most significant bits of the `PicOrderCntVal` of an IDR picture with `poc_reset_idc` equal to 0 are set equal to 0. As specified for the decoder conformance of output order DPB in F.13.5.2.2, an IDR picture with `nuh_layer_id` equal to `SmallestLayerId` does not cause the output of earlier access units, in decoding order, unless the IDR picture is a POC resetting picture, activates a new VPS, or causes `NoClasOutputFlag` to be derived to be equal to 1. Encoders should be cautious when using `poc_reset_idc` equal to 0 with IDR pictures to maintain the desired picture output order and to obey the constraints on the consistent relation of output times to picture order counts as well as the constraints on the output order of two pictures in different CVSs.

`poc_reset_period_id` identifies a POC resetting period. When not present, the value of `poc_reset_period_id` is inferred as follows:

- If there is no picture that is in the same layer as the current picture, precedes the current picture in decoding order, and has `poc_reset_period_id` present in the slice segment header, the value of `poc_reset_period_id` is inferred to be equal to 0.
- Otherwise, the value of `poc_reset_period_id` is inferred to be equal to `poc_reset_period_id` of the last of such pictures, in decoding order, that are in the same layer as the current picture, precede the current picture in decoding order, and has `poc_reset_period_id` present in the slice segment header.

NOTE 5 It is not prohibited for multiple pictures in a layer to have the same value of `poc_reset_period_id` and to have `poc_reset_idc` equal to 1 or 2 unless such pictures occur in two consecutive access units in decoding order. To minimize the likelihood of such two pictures appearing in the bitstream due to picture losses, bitstream extraction, seeking, or splicing operations, encoders should set the value of `poc_reset_period_id` to be a random value for each POC resetting period (subject to the constraints specified above).

It is a requirement of bitstream conformance that the following constraints apply:

- There shall be no two pictures consecutive in decoding order in the same layer that have the same value of `poc_reset_period_id` and `poc_reset_idc` equal to 1 or 2.
- One POC resetting period shall not include more than one access unit with `poc_reset_idc` equal to 1 or 2.
- An access unit with `poc_reset_idc` equal to 1 or 2 shall be the first access unit in a POC resetting period.

- A picture that follows, in decoding order, the first POC resetting picture among all layers of a POC resetting period in decoding order shall not precede, in output order, another picture in any layer that precedes the first POC resetting picture in decoding order.
- The value of poc_reset_period_id shall be the same for all pictures in an access unit.

full_poc_reset_flag equal to 1 specifies that both the most significant bits and the least significant bits of the picture order count value for the current picture are reset when the previous picture in decoding order in the same layer does not belong to the same POC resetting period. full_poc_reset_flag equal to 0 specifies that only the most significant bits of the picture order count value for the current picture are reset when the previous picture in decoding order in the same layer does not belong to the same POC resetting period.

It is a requirement of bitstream conformance that when the value of poc_reset_idc of pictures in the first access unit in the same POC resetting period is equal to 1 or 2, the value of full_poc_reset_flag, when present, shall be equal to poc_reset_idc – 1.

poc_lsb_val specifies a value that may be used to derive the picture order count of the current picture. The length of the poc_lsb_val syntax element is $\log_2 \text{max_pic_order_cnt_lsb_minus4} + 4$ bits.

When poc_lsb_not_present_flag[LayerIdxInVps[nuh_layer_id]] is equal to 1 and full_poc_reset_flag is equal to 1, the value of poc_lsb_val shall be equal to 0.

It is a requirement of bitstream conformance that, when poc_reset_idc is equal to 3, and the previous picture picA in decoding order that is in the same layer as the current picture, that has poc_reset_idc equal to 1 or 2, and that belongs to the same POC resetting period is present in the bitstream, picA shall be the same picture as the previous picture in decoding order that is in the same layer as the current picture, that is not a RASL, RADL, or SLNR picture, and that has TemporalId equal to 0 and discardable_flag equal to 0, and the value of poc_lsb_val of the current picture shall be equal to the value of slice_pic_order_cnt_lsb of picA.

The variable PocMsbValRequiredFlag is derived as follows:

$$\text{PocMsbValRequiredFlag} = \text{CraOrBlaPicFlag} \ \&\& \ (\ !\text{vps_poc_lsb_aligned_flag} \ | \ | \ \text{vps_poc_lsb_aligned_flag} \ \&\& \ \text{NumDirectRefLayers}[\text{nuh_layer_id}] = 0 \) \ \text{ (F-55)}$$

poc_msb_cycle_val_present_flag equal to 1 specifies that poc_msb_cycle_val is present. poc_msb_cycle_val_present_flag equal to 0 specifies that poc_msb_cycle_val is not present. When not present, the value of poc_msb_cycle_val_present_flag is inferred as follows:

- If slice_segment_header_extension_length is equal to 0, the value of poc_msb_cycle_val_present_flag is inferred to be equal to 0.
- Otherwise, if PocMsbValRequiredFlag is equal to 1, the value of poc_msb_cycle_val_present_flag is inferred to be equal to 1.
- Otherwise, the value of poc_msb_cycle_val_present_flag is inferred to be equal to 0.

NOTE 6 When the current picture is an IDR picture with nuh_layer_id equal to 0 and is a POC resetting picture, vps_poc_lsb_aligned_flag is equal to 1, and NumPredictedLayers[0] is greater than 0, poc_msb_cycle_val_present_flag is expected to be equal to 1.

poc_msb_cycle_val specifies the value that may be used to derive the picture order count value of the current picture or used to derive the value used to decrement the picture order count values of previously decoded pictures in the same layer as the current picture. When vps_poc_lsb_aligned_flag is equal to 1, poc_msb_cycle_val may also specify the value that is used to derive the value used to decrement the picture order count values of previously decoded pictures of the predicted layers of the current layer. The value of poc_msb_cycle_val shall be in the range of 0 to $2^{32 - \log_2 \text{max_pic_order_cnt_lsb_minus4} - 4}$, inclusive.

ISO/IEC 23008-2:2017(E)

NOTE 7 For a picture picA in layer layerA, let msbAnchorPic of the picture picA be the previous POC resetting picture in the layer layerA or the previous IDR picture that belongs to the layer layerA and has poc_msb_cycle_val_present_flag equal to 0, whichever is closer, in decoding order, to the picture picA. The value of poc_msb_cycle_val is set as follows:

- If vps_poc_lsb_aligned_flag is equal to 0, the following apply:
 - If either of the following conditions is true, the value of poc_msb_cycle_val can be any value in the allowed range:
 - msbAnchorPic of the current picture is not present.
 - the current picture is the first picture in the current layer that belongs to or follows an access unit that contains an IRAP picture with nuh_layer_id equal to SmallestLayerId and NoClrasOutputFlag equal to 1.
 - Otherwise, if the current picture is a POC resetting picture, the value of poc_msb_cycle_val is equal to the difference between the values of the most significant bits of the picture order counts of the current picture, as if there was no POC reset operation for the current picture, and msbAnchorPic of the current picture.
 - Otherwise (the current picture is not a POC resetting picture), the value of poc_msb_cycle_val is equal to the difference between the values of the most significant bits of the picture order count values of the current picture and msbAnchorPic of the current picture.
- Otherwise (vps_poc_lsb_aligned_flag is equal to 1), the following apply:
 - If the current picture is an IDR picture with nuh_layer_id equal to 0 and is a POC resetting picture, encoders should set the value of poc_msb_cycle_val as follows:
 - If picture picB other than the current picture is present in the current access unit, the difference between the most significant bits of the picture order counts of picB and msbAnchorPic of picB.
 - Otherwise (no picture picB other than the current picture is present in the current access unit), the difference between the most significant bits of the picture order counts of picB as if it would be present in the current access unit and msbAnchorPic of such a picB.
 - Otherwise, if the current picture is the first picture in the POC resetting period and has nuh_layer_id equal to SmallestLayerId, the value of poc_msb_cycle_val is equal to the difference between the values of the most significant bits of the picture order counts of the current picture, as if there was no POC reset operation for the current picture, and msbAnchorPic of the current picture.
 - Otherwise when the current picture is not a POC resetting picture, the value of poc_msb_cycle_val is equal to the difference between the values of the most significant bits of the picture order count values of the current picture and msbAnchorPic of the current picture.

slice_segment_header_extension_data_bit may have any value. Decoders shall ignore the value of slice_segment_header_extension_data_bit. Its value does not affect decoder conformance to profiles specified in this version of this document.

F.7.4.7.2 Reference picture list modification semantics

The specifications in 7.4.7.2 apply with following modifications:

- Formula (7-57) specifying the derivation of NumPicTotalCurr is replaced by:

```
NumPicTotalCurr = 0
if( nal_unit_type != IDR_W_RADL && nal_unit_type != IDR_N_LP ) {
```

```

    for( i = 0; i < NumNegativePics[ CurrRpsIdx ]; i++ )
        if( UsedByCurrPicS0[ CurrRpsIdx ][ i ] )
            NumPicTotalCurr++
    for( i = 0; i < NumPositivePics[ CurrRpsIdx ]; i++ )
        if( UsedByCurrPicS1[ CurrRpsIdx ][ i ] )
            NumPicTotalCurr++
    for( i = 0; i < num_long_term_sps + num_long_term_pics; i++ )
        if( UsedByCurrPicLt[ i ] )
            NumPicTotalCurr++
}
if( pps_curr_pic_ref_enabled_flag )
    NumPicTotalCurr++
NumPicTotalCurr += NumActiveRefLayerPics

```

(F-56)

F.7.4.7.3 Weighted prediction parameters semantics

The specifications in 7.4.7.3 apply.

F.7.4.8 Short-term reference picture set semantics

The specifications in 7.4.8 apply, with the following additions.

When `vps_extension_flag` is equal to 1, the value of `num_negative_pics` shall be in the range of 0 to `MaxDpbSize - 1`, inclusive, where `MaxDpbSize` is as specified in G.11.2 or H.11.2.

When `vps_extension_flag` is equal to 1, the value of `num_positive_pics` shall be in the range of 0 to `MaxDpbSize - 1 - num_negative_pics`, inclusive, where `MaxDpbSize` is as specified in G.11.2 or H.11.2.

F.7.4.9 Slice segment data semantics

F.7.4.9.1 General slice segment data semantics

The specifications in 7.4.9.1 apply.

F.7.4.9.2 Coding tree unit semantics

The specifications in 7.4.9.2 apply.

F.7.4.9.3 Sample adaptive offset semantics

The specifications in 7.4.9.3 apply.

F.7.4.9.4 Coding quadtree semantics

The specifications in 7.4.9.4 apply.

F.7.4.9.5 Coding unit semantics

The specifications in 7.4.9.5 apply.

F.7.4.9.6 Prediction unit semantics

The specifications in 7.4.9.6 apply.

F.7.4.9.7 PCM sample semantics

The specifications in 7.4.9.7 apply.

ISO/IEC 23008-2:2017(E)

F.7.4.9.8 Transform tree semantics

The specifications in 7.4.9.8 apply.

F.7.4.9.9 Motion vector difference semantics

The specifications in 7.4.9.9 apply.

F.7.4.9.10 Transform unit semantics

The specifications in 7.4.9.10 apply.

F.7.4.9.11 Residual coding semantics

The specifications in 7.4.9.11 apply.

F.7.4.9.12 Cross-component prediction syntax

The specifications in 7.4.9.12 apply.

F.7.4.9.13 Palette mode semantics

The specifications in 7.4.9.13 apply.

F.7.4.9.14 Delta QP semantics

The specifications in 7.4.9.14 apply.

F.7.4.9.15 Chroma QP offset semantics

The specifications in 7.4.9.15 apply.

F.8 Decoding process

F.8.1 General decoding process

F.8.1.1 General

Input to this process is a bitstream. Output of this process is a list of decoded pictures.

The decoding process is specified such that all decoders capable of decoding an OLS where each of the output layers and the reference layers of the output layers is indicated to conform to a specified profile, tier, and level will produce numerically identical cropped decoded output pictures when invoking the decoding process associated with those profiles for the OLS. Any decoding process that produces identical cropped decoded output pictures to those produced by the process described herein (with the correct output order or output timing, as specified) conforms to the decoding process requirements of this document.

The following apply at the beginning of decoding a CVSG, after activating the VPS RBSP that is active for the entire CVSG and before decoding any VCL NAL units of the CVSG:

- If `vps_extension()` is not present in the active VPS or a decoding process specified in Annex F is not in use, 8.1.2 is invoked with the CVSG as input.
- Otherwise [`vps_extension()` is present in the active VPS and a decoding process specified in Annex F is in use], F.8.1.2 is invoked with the CVSG as input.

F.8.1.2 CVSG decoding process

Input to this process is a CVSG. Output of this process is a list of decoded pictures.

The variable `TargetOlsIdx`, which specifies the index to the list of the OLSs specified by the VPS, of the target OLS, is specified as follows:

- If some external means, not specified in this document, is available to set `TargetOlsIdx`, `TargetOlsIdx` is set by the external means.
- Otherwise, if the decoding process is invoked in a bitstream conformance test as specified in F.13.1, `TargetOlsIdx` is set as specified in F.13.1.
- Otherwise, `TargetOlsIdx` is set equal to 0.

The variable `TargetDecLayerSetIdx`, the layer identifier list `TargetOptLayerIdList`, which specifies the list of `nuh_layer_id` values, in increasing order of `nuh_layer_id` values, of the pictures to be output, and the layer identifier list `TargetDecLayerIdList`, which specifies the list of `nuh_layer_id` values, in increasing order of `nuh_layer_id` values, of the NAL units to be decoded, are specified as follows:

```

TargetDecLayerSetIdx = OlsIdxToLsIdx[ TargetOlsIdx ]
lsIdx = TargetDecLayerSetIdx
for( i = 0, j = 0, k = 0; i < NumLayersInIdList[ lsIdx ]; i++ ) {
    if( NecessaryLayerFlag[ TargetOlsIdx ][ i ] )
        TargetDecLayerIdList[ j++ ] = LayerSetLayerIdList[ lsIdx ][ i ]
    if( OutputLayerFlag[ TargetOlsIdx ][ i ] )
        TargetOptLayerIdList[ k++ ] = LayerSetLayerIdList[ lsIdx ][ i ]
}

```

(F-57)

When `TargetOlsIdx` is set by external means, it is a requirement for the external means that `TargetOlsIdx` is constrained as follows:

- When `vps_base_layer_available_flag` is equal to 0, `OlsIdxToLsIdx[TargetOlsIdx]` shall be in the range of `FirstAddLayerSetIdx` to `LastAddLayerSetIdx`, inclusive.
- When `vps_base_layer_internal_flag` is equal to 0, `TargetOlsIdx` shall be greater than 0.

The variable `HighestTid`, which identifies the highest temporal sub-layer to be decoded, is specified as follows:

- If some external means, not specified in this document, is available to set `HighestTid`, `HighestTid` is set by the external means.
- Otherwise, if the decoding process is invoked in a bitstream conformance test as specified in F.13.1, `HighestTid` is set as specified in F.13.1.
- Otherwise, `HighestTid` is set equal to `sps_max_sub_layers_minus1`.

The variable `SubPicHrdPreferredFlag` is either specified by external means, or when not specified by external means, set equal to 0.

The variable `SubPicHrdFlag` is specified as follows:

- If the decoding process is invoked in a bitstream conformance test as specified in F.13.1, `SubPicHrdFlag` is set as specified in F.13.1.
- Otherwise, `SubPicHrdFlag` is set equal to (`SubPicHrdPreferredFlag && sub_pic_hrd_params_present_flag`), where `sub_pic_hrd_params_present_flag` is found in any

ISO/IEC 23008-2:2017(E)

hrd_parameters() syntax structure that applies to at least one bitstream partition of the output layer set identified by TargetOlsIdx.

A bitstream to be decoded, BitstreamToDecode, is specified as follows:

- If TargetDecLayerSetIdx is less than or equal to vps_num_layer_sets_minus1 and vps_base_layer_internal_flag is equal to 1, the following apply:
 - The sub-bitstream extraction process as specified in Clause 10 is applied with the CVSG, HighestTid, and TargetDecLayerIdList as inputs, and the output is assigned to a bitstream referred to as BitstreamToDecode.
 - The variable SmallestLayerId is set equal to 0.
- Otherwise, if TargetDecLayerSetIdx is less than or equal to vps_num_layer_sets_minus1 and vps_base_layer_internal_flag is equal to 0, the following apply:
 - The sub-bitstream extraction process as specified in F.10.1 is applied with the CVSG, HighestTid, and TargetDecLayerIdList as inputs, and the output is assigned to a bitstream referred to as BitstreamToDecode.
 - The variable SmallestLayerId is set equal to 0.
- Otherwise, if TargetDecLayerSetIdx is greater than vps_num_layer_sets_minus1 and NumLayersInIdList[TargetDecLayerSetIdx] is equal to 1, the following apply:
 - The independent non-base layer rewriting process of F.10.2 is applied with the CVSG, HighestTid, and TargetDecLayerIdList[0] as inputs, and the output is assigned to a bitstream referred to as BitstreamToDecode.
 - The variable SmallestLayerId is set equal to 0.
- Otherwise, the following apply:
 - The sub-bitstream extraction process as specified in F.10.3 is applied with the CVSG, HighestTid, and TargetDecLayerIdList as inputs, and the output is assigned to a bitstream referred to as BitstreamToDecode.
 - The variable SmallestLayerId is set equal to TargetDecLayerIdList[0].

When vps_base_layer_internal_flag is equal to 0, vps_base_layer_available_flag is equal to 1, and TargetDecLayerSetIdx is in the range of 0 to vps_num_layer_sets_minus1, inclusive, the following apply:

- The size of the sub-DPB for the layer with nuh_layer_id equal to 0 is set equal to 1.
- The values of pic_width_in_luma_samples, pic_height_in_luma_samples, chroma_format_idc, separate_colour_plane_flag, bit_depth_luma_minus8, bit_depth_chroma_minus8, conf_win_left_offset, conf_win_right_offset, conf_win_top_offset, and conf_win_bottom_offset for decoded pictures with nuh_layer_id equal to 0 are set equal to the values of pic_width_vps_in_luma_samples, pic_height_vps_in_luma_samples, chroma_format_vps_idc, separate_colour_plane_vps_flag, bit_depth_vps_luma_minus8, bit_depth_vps_chroma_minus8, conf_win_vps_left_offset, conf_win_vps_right_offset, conf_win_vps_top_offset, and conf_win_vps_bottom_offset respectively, of the vps_rep_format_idx[0]-th rep_format() syntax structure in the active VPS.
- The variable BaseLayerOutputFlag is set equal to (TargetOptLayerIdList[0] == 0).

NOTE The BaseLayerOutputFlag is to be sent by an external means to the base layer decoder for controlling the output of base layer decoded pictures. BaseLayerOutputFlag equal to 1 indicates that the base layer is an output layer. BaseLayerOutputFlag equal to 0 indicates that the base layer is not an output layer.

- The variable LayerInitializedFlag[*i*] is set equal to 0 for all values of *i* from 0 to vps_max_layer_id, inclusive, and the variable FirstPicInLayerDecodedFlag[*i*] is set equal to 0 for all values of *i* from 0 to vps_max_layer_id, inclusive.

If TargetOlsIdx is equal to 0, 8.1.3 is repeatedly invoked for each coded picture in BitstreamToDecode in decoding order and the decoding process for the current picture takes as inputs the syntax elements and upper-case variables from Clause 7.

Otherwise (TargetOlsIdx is greater than 0), F.8.1.3 is repeatedly invoked for each coded picture in BitstreamToDecode in decoding order.

F.8.1.3 Common decoding process for a coded picture

The decoding processes specified in the remainder of this clause apply to each coded picture, referred to as the current picture and denoted by the variable CurrPic, in BitstreamToDecode.

Depending on the value of chroma_format_idc, the number of sample arrays of the current picture is as follows:

- If chroma_format_idc is equal to 0, the current picture consists of 1 sample array S_L .
- Otherwise (chroma_format_idc is not equal to 0), the current picture consists of 3 sample arrays S_L , S_{Cb} , S_{Cr} .

When interpreting the semantics of each syntax element in each NAL unit, the term “the bitstream” (or part thereof, e.g. a CVS of the bitstream) refers to BitstreamToDecode (or part thereof).

When vps_base_layer_internal_flag is equal to 0, vps_base_layer_available_flag is equal to 1, TargetDecLayerSetIdx is in the range of 0 to vps_num_layer_sets_minus1, inclusive, TemporalId is less than or equal to sub_layers_vps_max_minus1[0], and the current picture is the first coded picture of an access unit, F.8.1.8 is invoked prior to decoding the current picture.

When the current picture is an IRAP picture, the variable HandleCraAsBlaFlag is derived as specified in the following:

- If some external means not specified in this document is available to set the variable HandleCraAsBlaFlag to a value for the current picture, the variable HandleCraAsBlaFlag is set equal to the value provided by the external means.
- Otherwise, the variable HandleCraAsBlaFlag is set equal to 0.

When the current picture is an IRAP picture and has nuh_layer_id equal to SmallestLayerId, the following apply:

- The variable NoClrasOutputFlag is specified as follows:
 - If the current picture is the first picture in the bitstream, NoClrasOutputFlag is set equal to 1.
 - Otherwise, if the current picture is included in the first access unit that follows an access unit including an end of sequence NAL unit with nuh_layer_id equal to SmallestLayerId or 0 in decoding order, NoClrasOutputFlag is set equal to 1.
 - Otherwise, if the current picture is a BLA picture or a CRA picture with HandleCraAsBlaFlag equal to 1, NoClrasOutputFlag is set equal to 1.

ISO/IEC 23008-2:2017(E)

- Otherwise, if the current picture is an IDR picture with `cross_layer_bla_flag` is equal to 1, `NoCrasOutputFlag` is set equal to 1.
- Otherwise, if some external means, not specified in this document, is available to set `NoCrasOutputFlag`, `NoCrasOutputFlag` is set by the external means.
- Otherwise, `NoCrasOutputFlag` is set equal to 0.
- When `NoCrasOutputFlag` is equal to 1, the variable `LayerInitializedFlag[i]` is set equal to 0 for all values of `i` from 0 to `vps_max_layer_id`, inclusive, and the variable `FirstPicInLayerDecodedFlag[i]` is set equal to 0 for all values of `i` from 0 to `vps_max_layer_id`, inclusive.

The variables `LayerResetFlag` and `dolLayerId` are derived as follows:

- If the current picture is an IRAP picture and has `nuh_layer_id` `nuhLayerId` greater than `SmallestLayerId`, the following apply:
 - If the current picture is the first picture, in decoding order, that follows an end of sequence NAL unit with `nuh_layer_id` equal to `nuhLayerId`, `LayerResetFlag` is set equal to 1 and `dolLayerId` is set equal to the `nuh_layer_id` value of the current NAL unit.
 - Otherwise, if the current picture is a CRA picture with `HandleCraAsBlaFlag` equal to 1, an IDR picture with `cross_layer_bla_flag` is equal to 1 or a BLA picture, `LayerResetFlag` is set equal to 1 and `dolLayerId` is set equal to the `nuh_layer_id` value of the current NAL unit.
 - Otherwise, `LayerResetFlag` is set equal to 0.

NOTE 1 An end of sequence NAL unit, a CRA picture with `HandleCraAsBlaFlag` equal to 1, an IDR picture with `cross_layer_bla_flag` equal to 1, or a BLA picture, each with `nuh_layer_id` `nuhLayerId` greater than `SmallestLayerId`, may be present to indicate a discontinuity of the layer with `nuh_layer_id` equal to `nuhLayerId` and its predicted layers.

- When `LayerResetFlag` is equal to 1, the following apply:
 - The values of `LayerInitializedFlag` and `FirstPicInLayerDecodedFlag` are updated as follows:

```
for( i = 0; i < NumPredictedLayers[ dolLayerId ]; i++ ) {  
    iLayerId = IdPredictedLayer[ dolLayerId ][ i ]  
    LayerInitializedFlag[ iLayerId ] = 0  
    FirstPicInLayerDecodedFlag[ iLayerId ] = 0  
}
```

(F-58)

- Each picture that is in the DPB and has `nuh_layer_id` equal to `dolLayerId` is marked as “unused for reference”.
- When `NumPredictedLayers[dolLayerId]` is greater than 0, each picture that is in the DPB and has `nuh_layer_id` equal to any value of `IdPredictedLayer[dolLayerId][i]` for the values of `i` in the range of 0 to `NumPredictedLayers[dolLayerId] - 1`, inclusive, is marked as “unused for reference”.

- Otherwise, `LayerResetFlag` is set equal to 0.

When the current picture is an IRAP picture, the following apply:

- If the current picture with a particular value of `nuh_layer_id` is an IDR picture, a BLA picture, the first picture with that particular value of `nuh_layer_id` in the bitstream in decoding order, or the first picture with that particular value of `nuh_layer_id` that follows an end of sequence NAL unit

with that particular value of `nuh_layer_id` in decoding order, the variable `NoRaslOutputFlag` is set equal to 1.

- Otherwise, if `LayerInitializedFlag[nuh_layer_id]` is equal to 0 and `LayerInitializedFlag[refLayerId]` is equal to 1 for all values of `refLayerId` equal to `IdDirectRefLayer[nuh_layer_id][j]`, where `j` is in the range of 0 to `NumDirectRefLayers[nuh_layer_id] - 1`, inclusive, the variable `NoRaslOutputFlag` is set equal to 1.
- Otherwise, the variable `NoRaslOutputFlag` is set equal to `HandleCraAsBlaFlag`.

When the current picture is an IRAP picture with `NoRaslOutputFlag` equal to 1 and one of the following conditions is true, `LayerInitializedFlag[nuh_layer_id]` is set equal to 1:

- `nuh_layer_id` is equal to 0.
- `LayerInitializedFlag[nuh_layer_id]` is equal to 0 and `NumDirectRefLayers[nuh_layer_id]` is equal to 0.
- `LayerInitializedFlag[nuh_layer_id]` is equal to 0 and `LayerInitializedFlag[refLayerId]` is equal to 1 for all values of `refLayerId` equal to `IdDirectRefLayer[nuh_layer_id][j]`, where `j` is in the range of 0 to `NumDirectRefLayers[nuh_layer_id] - 1`, inclusive.

Depending on the value of `separate_colour_plane_flag`, the decoding process is structured as follows:

- If `separate_colour_plane_flag` is equal to 0, the following decoding process is invoked a single time with the current picture being the output.
- Otherwise (`separate_colour_plane_flag` is equal to 1), the following decoding process is invoked three times. Inputs to the decoding process are all NAL units of the coded picture with identical value of `colour_plane_id`. The decoding process of NAL units with a particular value of `colour_plane_id` is specified as if only a CVS with monochrome colour format with that particular value of `colour_plane_id` would be present in the bitstream. The output of each of the three decoding processes is assigned to one of the 3 sample arrays of the current picture, with the NAL units with `colour_plane_id` equal to 0, 1, and 2 being assigned to `SL`, `SCb`, and `SCr`, respectively.

NOTE 2 The variable `ChromaArrayType` is derived as equal to 0 when `separate_colour_plane_flag` is equal to 1 and `chroma_format_idc` is equal to 3. In the decoding process, the value of this variable is evaluated resulting in operations identical to that of monochrome pictures (when `chroma_format_idc` is equal to 0).

The following applies for the decoding of the current picture:

- If the current picture has `nuh_layer_id` equal to 0, the following apply:
 - The decoding process for the current picture takes as inputs the syntax elements and upper-case variables from F.7.
 - The variables `NumActiveRefLayerPics`, `NumActiveRefLayerPics0`, and `NumActiveRefLayerPics1` are set equal to 0.
 - The decoding process for a coded picture with `nuh_layer_id` equal to 0 as specified in F.8.1.4 is invoked.
- Otherwise, the following apply:
 - When `vps_base_layer_internal_flag` is equal to 0, `vps_base_layer_available_flag` is equal to 1, `TargetDecLayerSetIdx` is in the range of 0 to `vps_num_layer_sets_minus1`, inclusive, `TemporalId` is less than or equal to `sub_layers_vps_max_minus1[0]`, the current picture is the

first coded picture of an access unit, and a decoded picture with `nuh_layer_id` equal to 0 is provided by external means for the current access unit, F.8.1.9 is invoked after the decoding of the slice segment header of the first slice segment, in decoding order, of the current picture, but prior to decoding any slice segment of the first coded picture of the access unit.

- For the decoding of the slice segment header of the first slice segment, in decoding order, of the current picture, the decoding process for starting the decoding of a coded picture with `nuh_layer_id` greater than 0 specified in F.8.1.5 is invoked.
- Let `lIdx` be equal to such value for which the `nuh_layer_id` value of the current picture is equal to `LayerSetLayerIdList[OlsIdxToLsIdx[TargetOlsIdx]][lIdx]`.
- If `general_profile_idc` in the `profile_tier_level()` syntax structure `VpsProfileTierLevel[profile_tier_level_idx[TargetOlsIdx][lIdx]]` is equal to 6, the decoding process for the current picture takes as inputs the syntax elements and upper-case variables from G.7 and the decoding process of G.8.1.2 is invoked.
- Otherwise, if `general_profile_idc` in the `profile_tier_level()` syntax structure `VpsProfileTierLevel[profile_tier_level_idx[TargetOlsIdx][lIdx]]` is equal to 7 or 10, the decoding process for the current picture takes as inputs the syntax elements and upper-case variables from H.7 and the decoding process of H.8.1.2 is invoked.
- Otherwise, if `general_profile_idc` in the `profile_tier_level()` syntax structure `VpsProfileTierLevel[profile_tier_level_idx[TargetOlsIdx][lIdx]]` is equal to 8, the decoding process for the current picture takes as inputs the syntax elements and upper-case variables from I.7 and the decoding process of I.8.1.2 is invoked.
- Otherwise (the current picture belongs to an independent non-base layer), the decoding process for the current picture takes as inputs the syntax elements and upper-case variables from F.7 and the decoding process of 8.1.3 is invoked by changing the references to 8.2, 8.3, 8.3.1, 8.3.2, 8.3.3, 8.3.4, 8.4, 8.5, 8.6, and 8.7 with F.8.2, F.8.3, F.8.3.1, F.8.3.2, F.8.3.3, F.8.3.4, F.8.4, F.8.5, F.8.6, and F.8.7, respectively.
- After all slices of the current picture have been decoded, the decoding process for ending the decoding of a coded picture with `nuh_layer_id` greater than 0 specified in F.8.1.6 is invoked.

When the current picture is the last coded picture in an access unit in `BitstreamToDecode`, after the decoding of the current picture, prior to the decoding of the next picture, the following apply:

- `PicOutputFlag` is updated as follows:
 - If `alt_output_layer_flag[TargetOlsIdx]` is equal to 1 and the current access unit either does not contain a picture at the output layer or contains a picture at the output layer that has `PicOutputFlag` equal to 0, the following apply:
 - The list `nonOutputLayerPictures` is set to be the list of the pictures of the access unit with `PicOutputFlag` equal to 1 and with `nuh_layer_id` values among the `nuh_layer_id` values of the reference layers of the output layer.
 - When the list `nonOutputLayerPictures` is not empty, the picture with the highest `nuh_layer_id` value among the list `nonOutputLayerPictures` is removed from the list `nonOutputLayerPictures`.
 - `PicOutputFlag` for each picture that is included in the list `nonOutputLayerPictures` is set equal to 0.

- Otherwise, PicOutputFlag for pictures that are not included in an output layer is set equal to 0.
 - When vps_base_layer_internal_flag is equal to 0, vps_base_layer_available_flag is equal to 1, and TargetDecLayerSetIdx is in the range of 0 to vps_num_layer_sets_minus1, inclusive, the following apply:
 - If BaseLayerOutputFlag is equal to 0, the following apply:
 - If alt_output_layer_flag[TargetOlsIdx] is equal to 1, the base layer is a reference layer of the output layer, the access unit does not contain a picture at the output layer or contains a picture at the output layer that has PicOutputFlag equal to 0, and the access unit does not contain a picture at any other reference layer of the output layer, BaseLayerPicOutputFlag is set equal to 1.
 - Otherwise, BaseLayerPicOutputFlag is set equal to 0.
 - Otherwise, BaseLayerPicOutputFlag is set equal to 1.
- NOTE 3 The BaseLayerPicOutputFlag for each access unit is to be sent by an external means to the base layer decoder for controlling the output of base layer decoded pictures. BaseLayerPicOutputFlag equal to 1 for an access unit specifies that the base layer picture of the access unit is to be output. BaseLayerPicOutputFlag equal to 0 for an access unit specifies that the base layer picture of the access unit is not to be output.
- The sub-DPB for the layer with nuh_layer_id equal to 0 is set to be empty.
 - The variable AuOutputFlag that is associated with the current access unit is derived as follows:
 - If at least one picture in the current access unit has PicOutputFlag equal to 1, AuOutputFlag is set equal to 1.
 - Otherwise, AuOutputFlag is set equal to 0.
 - The variable PicLatencyCount that is associated with the current access unit is set equal to 0.
 - When AuOutputFlag of the current access unit is equal to 1, for each access unit in the DPB that has at least one picture marked as "needed for output" and follows the current access unit in output order, the associated variable PicLatencyCount is set equal to PicLatencyCount + 1.

F.8.1.4 Decoding process for a coded picture with nuh_layer_id equal to 0

The specifications in 8.1.3 apply with the following changes:

- Replace the references to 8.2, 8.3, 8.3.1, 8.3.2, 8.3.3, 8.3.4, 8.4, 8.5, 8.6, and 8.7 with F.8.2, F.8.3, F.8.3.1, F.8.3.2, F.8.3.3, F.8.3.4, F.8.4, F.8.5, F.8.6, and F.8.7, respectively.
- At the end of the clause, add item 5 as follows:
 5. When FirstPicInLayerDecodedFlag[0] is equal to 0, FirstPicInLayerDecodedFlag[0] is set equal to 1.

F.8.1.5 Decoding process for starting the decoding of a coded picture with nuh_layer_id greater than 0

Each picture referred to in this clause is a complete coded picture.

The decoding process operates as follows for the current picture CurrPic:

1. The decoding of NAL units is specified in F.8.2.
2. The processes in F.8.3 specify the following decoding processes using syntax elements in the slice segment layer and above:

- Variables and functions relating to picture order count are derived in F.8.3.1. This needs to be invoked only for the first slice segment of a picture. It is a requirement of bitstream conformance that `PicOrderCntVal` of each picture in an access unit shall have the same value during and at the end of decoding of the access unit.

NOTE 1 When the current picture is or succeeds, in decoding order, an IDR picture with `nuh_layer_id` equal to 0, `PicOrderCntVal` of a base layer picture `picA` preceding, in decoding order, the IDR picture with `nuh_layer_id` equal to 0 may or may not be equal to `PicOrderCntVal` of the pictures with `nuh_layer_id` greater than 0 in the access unit containing `picA`.

- The decoding process for RPS in F.8.3.2 is invoked, wherein only reference pictures with `nuh_layer_id` equal to that of `CurrPic` may be marked as “unused for reference” or “used for long-term reference” and any picture with a different value of `nuh_layer_id` is not marked. This needs to be invoked only for the first slice segment of a picture.
- A picture storage buffer in the DPB is allocated for storage of the decoded sample values of the current picture after the invocation of the in-loop filter process as specified in F.8.7. This version of the current decoded picture is referred to as the current decoded picture after the invocation of the in-loop filter process. When `TwoVersionsOfCurrDecPicFlag` is equal to 0 and `pps_curr_pic_ref_enabled_flag` is equal to 1, this picture storage buffer is marked as “used for long-term reference”. When `TwoVersionsOfCurrDecPicFlag` is equal to 1, another picture storage buffer in the DPB is allocated for storage of the decoded sample values of the current picture immediately before the invocation of the in-loop filter process as specified in F.8.7, and is marked as “used for long-term reference”. This version of the current decoded picture is referred to as the current decoded picture before the invocation of the in-loop filter process. This needs to be invoked only for the first slice segment of a picture.

NOTE 2 When `TwoVersionsOfCurrDecPicFlag` is equal to 0, there is only one version of the current decoded picture. In this case, if `pps_curr_pic_ref_enabled_flag` is equal to 1, the current decoded picture is marked as “used for long-term reference” during the decoding of the current picture and will be marked as “used for short-term reference” at the end of the decoding of the current picture, otherwise it is not marked at all during the decoding of the current picture and will be marked as “used for short-term reference” at the end of the decoding of the current picture. When `TwoVersionsOfCurrDecPicFlag` is equal to 1, there are two versions of the current decoded picture, one of which is marked as “used for long-term reference” during the decoding of the current picture and will be marked as “unused for reference” at the end of the decoding of the current picture, and the other version is not marked at all during the decoding of the current picture and will be marked as “used for short-term reference” at the end of the decoding of the current picture.

- When `FirstPicInLayerDecodedFlag[nuh_layer_id]` is equal to 0, the decoding process for generating unavailable reference pictures for pictures first in decoding order within a layer specified in F.8.1.7 is invoked, which needs to be invoked only for the first slice segment of a picture.
- When `FirstPicInLayerDecodedFlag[nuh_layer_id]` is equal to 1 and the current picture is an IRAP picture with `NoRaslOutputFlag` equal to 1, the decoding process for generating unavailable reference pictures specified in F.8.3.3 is invoked, which needs to be invoked only for the first slice segment of a picture.

F.8.1.6 Decoding process for ending the decoding of a coded picture with nuh_layer_id greater than 0

The marking of decoded pictures is modified as specified in the following:

```
for( i = 0; i < NumActiveRefLayerPics0; i++ )
  RefPicSetInterLayer0[ i ] is marked as "used for short-term reference"
for( i = 0; i < NumActiveRefLayerPics1; i++ )
  RefPicSetInterLayer1[ i ] is marked as "used for short-term reference"
(F-59)
```

PicOutputFlag is set as follows:

- If LayerInitializedFlag[nuh_layer_id] is equal to 0, PicOutputFlag is set equal to 0.
- Otherwise, if the current picture is a RASL picture and NoRaslOutputFlag of the associated IRAP picture is equal to 1, PicOutputFlag is set equal to 0.
- Otherwise, PicOutputFlag is set equal to pic_output_flag.

The current decoded picture after the invocation of the in-loop filter process as specified in 8.7 is marked as "used for short-term reference".

When FirstPicInLayerDecodedFlag[nuh_layer_id] is equal to 0, FirstPicInLayerDecodedFlag[nuh_layer_id] is set equal to 1.

F.8.1.7 Decoding process for generating unavailable reference pictures for pictures first in decoding order within a layer

This process is invoked for a picture with nuh_layer_id equal to layerId, when FirstPicInLayerDecodedFlag[layerId] is equal to 0.

NOTE The entire specification of the decoding process for CL-RAS pictures is included only for purposes of specifying constraints on the allowed syntax content of such CL-RAS pictures. During the decoding process, any CL-RAS pictures may be ignored, as these pictures are not specified for output and have no effect on the decoding process of any other pictures that are specified for output. However, in the HRD operations as specified in F.13, CL-RAS pictures may need to be taken into consideration in the derivation of CPB arrival and removal times.

When this process is invoked, the following apply:

- For each RefPicSetStCurrBefore[i], with i in the range of 0 to NumPocStCurrBefore – 1, inclusive, that is equal to "no reference picture", a picture is generated as specified in 8.3.3.2, and the following apply:
 - The value of PicOrderCntVal for the generated picture is set equal to PocStCurrBefore[i].
 - The value of PicOutputFlag for the generated picture is set equal to 0.
 - The generated picture is marked as "used for short-term reference".
 - RefPicSetStCurrBefore[i] is set to be the generated reference picture.
 - The value of nuh_layer_id for the generated picture is set equal to nuh_layer_id.
- For each RefPicSetStCurrAfter[i], with i in the range of 0 to NumPocStCurrAfter – 1, inclusive, that is equal to "no reference picture", a picture is generated as specified in 8.3.3.2, and the following apply:
 - The value of PicOrderCntVal for the generated picture is set equal to PocStCurrAfter[i].

ISO/IEC 23008-2:2017(E)

- The value of PicOutputFlag for the generated picture is set equal to 0.
- The generated picture is marked as "used for short-term reference".
- RefPicSetStCurrAfter[i] is set to be the generated reference picture.
- The value of nuh_layer_id for the generated picture is set equal to nuh_layer_id.
- For each RefPicSetStFoll[i], with i in the range of 0 to NumPocStFoll – 1, inclusive, that is equal to "no reference picture", a picture is generated as specified in 8.3.3.2, and the following apply:
 - The value of PicOrderCntVal for the generated picture is set equal to PocStFoll[i].
 - The value of PicOutputFlag for the generated picture is set equal to 0.
 - The generated picture is marked as "used for short-term reference".
 - RefPicSetStFoll[i] is set to be the generated reference picture.
 - The value of nuh_layer_id for the generated picture is set equal to nuh_layer_id.
- For each RefPicSetLtCurr[i], with i in the range of 0 to NumPocLtCurr – 1, inclusive, that is equal to "no reference picture", a picture is generated as specified in 8.3.3.2, and the following apply:
 - The value of PicOrderCntVal for the generated picture is set equal to PocLtCurr[i].
 - The value of slice_pic_order_cnt_lsb for the generated picture is inferred to be equal to (PocLtCurr[i] & (MaxPicOrderCntLsb – 1)).
 - The value of PicOutputFlag for the generated picture is set equal to 0.
 - The generated picture is marked as "used for long-term reference".
 - RefPicSetLtCurr[i] is set to be the generated reference picture.
 - The value of nuh_layer_id for the generated picture is set equal to nuh_layer_id.
- For each RefPicSetLtFoll[i], with i in the range of 0 to NumPocLtFoll – 1, inclusive, that is equal to "no reference picture", a picture is generated as specified in 8.3.3.2, and the following apply:
 - The value of PicOrderCntVal for the generated picture is set equal to PocLtFoll[i].
 - The value of slice_pic_order_cnt_lsb for the generated picture is inferred to be equal to (PocLtFoll[i] & (MaxPicOrderCntLsb – 1)).
 - The value of PicOutputFlag for the generated picture is set equal to 0.
 - The generated picture is marked as "used for long-term reference".
 - RefPicSetLtFoll[i] is set to be the generated reference picture.
 - The value of nuh_layer_id for the generated picture is set equal to nuh_layer_id.

F.8.1.8 Initialization process for an external base layer picture

A decoded picture with `nuh_layer_id` equal to 0 may be provided by external means. When not provided, no picture with `nuh_layer_id` equal to 0 is used for inter-layer prediction for the current access unit. When provided, the following apply:

- The variable `LayerInitializedFlag[0]` is set equal to 1 and the variable `FirstPicInLayerDecodedFlag[0]` is set equal to 1.
- The following information of the picture with `nuh_layer_id` equal to 0 for the access unit is provided by external means:
 - The decoded sample values (1 sample array S_L if `chroma_format_idc` is equal to 0 or 3 sample arrays S_L , S_{Cb} , and S_{Cr} otherwise).
 - The value of the variable `BllrapPicFlag`, and when `BllrapPicFlag` is equal to 1, the value of `nal_unit_type` of the decoded picture.
 - `BllrapPicFlag` equal to 1 specifies that the decoded picture is an IRAP picture. `BllrapPicFlag` equal to 0 specifies that the decoded picture is a non-IRAP picture.
 - The provided value of `nal_unit_type` of the decoded picture shall be equal to `IDR_W_RADL`, `CRA_NUT`, or `BLA_W_LP`.
 - `nal_unit_type` equal to `IDR_W_RADL` specifies that the decoded picture is an IDR picture.
 - `nal_unit_type` equal to `CRA_NUT` specifies that the decoded picture is a CRA picture.
 - `nal_unit_type` equal to `BLA_W_LP` specifies that the decoded picture is a BLA picture.
- When `BllrapPicFlag` of the picture with `nuh_layer_id` equal to 0 is equal to 1, the following applies for the decoded picture with `nuh_layer_id` equal to 0 for the access unit:
 - The variable `NoRaslOutputFlag` is specified as follows:
 - If `nal_unit_type` is `IDR_W_RADL` or `BLA_W_LP`, the variable `NoRaslOutputFlag` is set equal to 1.
 - Otherwise, if the current access unit is the first access unit in the bitstream in decoding order, the variable `NoRaslOutputFlag` is set equal to 1.
 - Otherwise, the variable `NoRaslOutputFlag` is set equal to 0.
 - The variable `NoClrasOutputFlag` is specified as follows:
 - If the current access unit is the first access unit in the bitstream, `NoClrasOutputFlag` is set equal to 1.
 - Otherwise, if `nal_unit_type` is equal to `BLA_W_LP`, `NoClrasOutputFlag` is set equal to 1.
 - Otherwise, if some external means, not specified in this document, is available to set `NoClrasOutputFlag`, `NoClrasOutputFlag` is set by the external means.
 - Otherwise, `NoClrasOutputFlag` is set equal to 0.

ISO/IEC 23008-2:2017(E)

- When NoClasOutputFlag is equal to 1, the variable LayerInitializedFlag[*i*] is set equal to 0 for all values of *i* from 1 to vps_max_layer_id, inclusive, and the variable FirstPicInLayerDecodedFlag[*i*] is set equal to 0 for all values of *i* from 1 to vps_max_layer_id, inclusive.

F.8.1.9 Decoding process for an external base layer picture

The following applies for the decoded picture with nuh_layer_id equal to 0 for the access unit:

- TemporalId and PicOrderCntVal of the decoded picture with nuh_layer_id equal to 0 are set equal to the TemporalId and PicOrderCntVal, respectively, of any picture with nuh_layer_id greater than 0 in the access unit.

NOTE The constraint on the value of TemporalId being required to be equal to 0 for IRAP pictures also applies to pictures with nuh_layer_id equal to 0 when vps_base_layer_internal_flag is equal to 0.

- The decoded picture with nuh_layer_id equal to 0 is stored in the sub-DPB for the layer with nuh_layer_id equal to 0 and is marked as "used for long-term reference".

F.8.2 NAL unit decoding process

The specifications in 8.2 apply.

F.8.3 Slice decoding processes

F.8.3.1 Decoding process for picture order count

Output of this process is PicOrderCntVal, the picture order count of the current picture.

Picture order counts are used to identify pictures, for deriving motion parameters in merge mode and motion vector prediction, and for decoder conformance checking (see F.13.5).

Each coded picture is associated with a picture order count variable, denoted as PicOrderCntVal.

When the current picture is the first picture among all layers of a POC resetting period, the variable PocDecrementInDPBFlag[*i*] is set equal to 0 for each value of *i* in the range of 0 to 62, inclusive.

The variable pocResettingFlag is derived as follows:

- If the current picture is a POC resetting picture, the following apply:
 - If vps_poc_lsb_aligned_flag is equal to 0, pocResettingFlag is set equal to 1.
 - Otherwise, if PocDecrementInDPBFlag[nuh_layer_id] is equal to 1, pocResettingFlag is set equal to 0.
 - Otherwise, pocResettingFlag is set equal to 1.
- Otherwise, pocResettingFlag is set equal to 0.

The list affectedLayerList is derived as follows:

- If vps_poc_lsb_aligned_flag is equal to 0, affectedLayerList consists of the nuh_layer_id of the current picture.
- Otherwise, affectedLayerList consists of the nuh_layer_id of the current picture and the nuh_layer_id values equal to IdPredictedLayer[currNuhLayerId][*j*] for all values of *j* in the range of 0 to NumPredictedLayers[currNuhLayerId] - 1, inclusive, where currNuhLayerId is the nuh_layer_id value of the current picture.

Depending on pocResetFlag, the following apply:

— If pocResetFlag is equal to 1, the following apply:

— When FirstPicInLayerDecodedFlag[nuh_layer_id] is equal to 1, the following apply:

— The variables pocMsbDelta, pocLsbDelta and DeltaPocVal are derived as follows:

```

if( poc_reset_idc == 3 )
    pocLsbVal = poc_lsb_val
else
    pocLsbVal = slice_pic_order_cnt_lsb
if( poc_msb_cycle_val_present_flag )
    pocMsbDelta = poc_msb_cycle_val * MaxPicOrderCntLsb
else {
    prevPicOrderCntLsb =
    PrevPicOrderCnt[ nuh_layer_id ] & ( MaxPicOrderCntLsb - 1 )
    prevPicOrderCntMsb = PrevPicOrderCnt[ nuh_layer_id ] - prevPicOrderCntLsb
    pocMsbDelta = GetCurrMsb( pocLsbVal, prevPicOrderCntLsb,
    prevPicOrderCntMsb,
    MaxPicOrderCntLsb )
}
if( poc_reset_idc == 2 || ( poc_reset_idc == 3 && full_poc_reset_flag ) )
    pocLsbDelta = pocLsbVal
else
    pocLsbDelta = 0
DeltaPocVal = pocMsbDelta + pocLsbDelta

```

(F-60)

— The PicOrderCntVal of each picture that has nuh_layer_id value nuhLayerId for which PocDecrementInDPBFlag[nuhLayerId] is equal to 0 and that is equal to any value in affectedLayerList is decremented by DeltaPocVal.

— PocDecrementInDPBFlag[nuhLayerId] is set equal to 1 for each value of nuhLayerId included in affectedLayerList.

— The PicOrderCntVal of the current picture is derived as follows:

```

if( poc_reset_idc == 1 )
    PicOrderCntVal = slice_pic_order_cnt_lsb
else if( poc_reset_idc == 2 )
    PicOrderCntVal = 0
else {
    PicOrderCntMsb =
    GetCurrMsb( slice_pic_order_cnt_lsb, full_poc_reset_flag ? 0 : poc_lsb_val,
    0, MaxPicOrderCntLsb )
    PicOrderCntVal = PicOrderCntMsb + slice_pic_order_cnt_lsb
}

```

(F-61)

— Otherwise (pocResetFlag is equal to 0), the following applies:

— The PicOrderCntVal of the current picture is derived as follows:

```

if( poc_msb_cycle_val_present_flag )
    PicOrderCntMsb = poc_msb_cycle_val * MaxPicOrderCntLsb
else if( !FirstPicInLayerDecodedFlag[ nuh_layer_id ] ||
    nal_unit_type == IDR_N_LP || nal_unit_type == IDR_W_RADL )

```

```

    PicOrderCntMsb = 0
else {
    prevPicOrderCntLsb =
    PrevPicOrderCnt[ nuh_layer_id ] & ( MaxPicOrderCntLsb - 1 )
    prevPicOrderCntMsb = PrevPicOrderCnt[ nuh_layer_id ] - prevPicOrderCntLsb
    PicOrderCntMsb = GetCurrMsb( slice_pic_order_cnt_lsb, prevPicOrderCntLsb,
    prevPicOrderCntMsb, MaxPicOrderCntLsb )
}
PicOrderCntVal = PicOrderCntMsb + slice_pic_order_cnt_lsb

```

(F-62)

The value of PrevPicOrderCnt[lld] for each of the lld values included in affectedLayerList is derived as follows:

- If the current picture is not a RASL, RADL, or SLNR picture, and the current picture has TemporalId equal to 0 and discardable_flag equal to 0, PrevPicOrderCnt[lld] is set equal to PicOrderCntVal.
- Otherwise, when poc_reset_idc is equal to 3 and one of the following conditions is true, PrevPicOrderCnt[lld] is set equal to (full_poc_reset_flag ? 0 : poc_lsb_val):
 - FirstPicInLayerDecodedFlag[nuh_layer_id] is equal to 0.
 - FirstPicInLayerDecodedFlag[nuh_layer_id] is equal to 1 and the current picture is a POC resetting picture.

The value of PicOrderCntVal shall be in the range of -2^{31} to $2^{31} - 1$, inclusive.

It is a requirement of bitstream conformance that the current PicOrderCntVal values of any two pictures in the same layer and the same CVS shall not be the same.

NOTE 1 PicOrderCntVal, as derived in this subclause for the current picture, may be equal to initialPocVal, where initialPocVal is the PicOrderCntVal derived by this subclause when an earlier picture, in decoding order, with nuh_layer_id equal to currNuhLayerId in the current CVS, was the current picture. However, the decoding processes applied subsequently have updated the PicOrderCntVal value for that earlier picture so that it no longer is equal to the PicOrderCntVal value derived in this clause for the current picture.

The function PicOrderCnt(picX) is specified as follows:

$$\text{PicOrderCnt(picX)} = \text{PicOrderCntVal of the picture picX} \quad (\text{F-63})$$

The function DiffPicOrderCnt(picA, picB) is specified as follows:

$$\text{DiffPicOrderCnt(picA, picB)} = \text{PicOrderCnt(picA)} - \text{PicOrderCnt(picB)} \quad (\text{F-64})$$

The bitstream shall not contain data that result in values of DiffPicOrderCnt(picA, picB) used in the decoding process that are not in the range of -2^{15} to $2^{15} - 1$, inclusive.

NOTE 2 Let X be the current picture and Y and Z be two other pictures in the same sequence, Y and Z are considered to be in the same output order direction from X when both DiffPicOrderCnt(X, Y) and DiffPicOrderCnt(X, Z) are positive or both are negative.

F.8.3.2 Decoding process for reference picture set

The specifications in 8.3.2 apply with the following changes:

- The references to 7.4.7.2, 8.3.1, 8.3.3, and 8.3.4 are replaced with references to F.7.4.7.2, F.8.3.1, F.8.3.3, and F.8.3.4, respectively.
- The following specifications are added:

- When the current picture is an IRAP picture with `nuh_layer_id` equal to `SmallestLayerId`, all reference pictures with any value of `nuh_layer_id` currently in the DPB (if any) are marked as “unused for reference” when at least one of the following conditions is true:
 - The current picture has `NoCtcrasOutputFlag` is equal to 1.
 - The current picture activates a new VPS.
- It is a requirement of bitstream conformance that the RPS is restricted as follows:
 - When the current picture is a CRA picture, there shall be no picture in `RefPicSetStCurrBefore`, `RefPicSetStCurrAfter`, or `RefPicSetLtCurr`.
- The constraints specified in 8.3.2 on the value of `NumPicTotalCurr` are replaced with the following:
 - It is a requirement of bitstream conformance that the following applies to the value of `NumPicTotalCurr`:
 - If the current picture is a BLA or CRA picture and either `currPicLayerId` is equal to 0 or `NumDirectRefLayers[currPicLayerId]` is equal to 0, the value of `NumPicTotalCurr` shall be equal to `pps_curr_pic_ref_enabled_flag`.
 - Otherwise, when the current picture contains a P or B slice, the value of `NumPicTotalCurr` shall not be equal to 0.
- The constraint, specified in 8.3.2, that requires no entry in `RefPicSetStCurrBefore`, `RefPicSetStCurrAfter`, or `RefPicSetLtCurr` when one or more of three conditions are true is replaced with the following:
 - There shall be no entry in `RefPicSetStCurrBefore`, `RefPicSetStCurrAfter`, or `RefPicSetLtCurr` for which one or more of the following are true:
 - The entry is equal to “no reference picture” and `FirstPicInLayerDecodedFlag[currPicLayerId]` is equal to 1.
 - The entry is an SLNR picture and has `TemporalId` equal to that of the current picture.
 - The entry is a picture that has `TemporalId` greater than that of the current picture.

F.8.3.3 Decoding process for generating unavailable reference pictures

The specifications in 8.3.3 and its subclauses apply with the replacement of references to Annex C with references to F.13.

F.8.3.4 Decoding process for reference picture lists construction

This process is invoked at the beginning of the decoding process for each P or B slice.

Reference pictures are addressed through reference indices as specified in 8.5.3.3.2. A reference index is an index into a reference picture list. When decoding a P slice, there is a single reference picture list `RefPicList0`. When decoding a B slice, there is a second independent reference picture list `RefPicList1` in addition to `RefPicList0`.

At the beginning of the decoding process for each slice, the reference picture lists `RefPicList0` and, for B slices, `RefPicList1` are derived as follows.

If `TwoVersionsOfCurrDecPicFlag` is equal to 1, let the variable `currPic` be the current decoded picture before the invocation of the in-loop filter process; otherwise (`TwoVersionsOfCurrDecPicFlag` is equal to

ISO/IEC 23008-2:2017(E)

0), let the variable currPic be the current decoded picture after the invocation of the in-loop filter process. The variable NumRpsCurrTempList0 is set equal to $\text{Max}(\text{num_ref_idx_l0_active_minus1} + 1, \text{NumPicTotalCurr})$ and the list RefPicListTemp0 is constructed as follows:

```
rIdx = 0
while( rIdx < NumRpsCurrTempList0 ) {
    for( i = 0; i < NumPocStCurrBefore && rIdx < NumRpsCurrTempList0; rIdx++, i++ )
        RefPicListTemp0[ rIdx ] = RefPicSetStCurrBefore[ i ]
    for( i = 0; i < NumActiveRefLayerPics0; rIdx++, i++ )
        RefPicListTemp0[ rIdx ] = RefPicSetInterLayer0[ i ]
    for( i = 0; i < NumPocStCurrAfter && rIdx < NumRpsCurrTempList0; rIdx++, i++ )           (F-65)
        RefPicListTemp0[ rIdx ] = RefPicSetStCurrAfter[ i ]
    for( i = 0; i < NumPocLtCurr && rIdx < NumRpsCurrTempList0; rIdx++, i++ )
        RefPicListTemp0[ rIdx ] = RefPicSetLtCurr[ i ]
    for( i = 0; i < NumActiveRefLayerPics1; rIdx++, i++ )
        RefPicListTemp0[ rIdx ] = RefPicSetInterLayer1[ i ]
    if( pps_curr_pic_ref_enabled_flag )
        RefPicListTemp0[ rIdx++ ] = currPic
}
```

The list RefPicList0 is constructed as follows:

```
for( rIdx = 0; rIdx <= num_ref_idx_l0_active_minus1; rIdx++ )
    RefPicList0[ rIdx ] = ref_pic_list_modification_flag_l0 ? RefPicListTemp0[ list_entry_l0[ rIdx ] ] :
                                                                RefPicListTemp0[ rIdx ]
if( pps_curr_pic_ref_enabled_flag && !ref_pic_list_modification_flag_l0 &&                               (F-66)
    NumRpsCurrTempList0 > ( num_ref_idx_l0_active_minus1 + 1 ) )
    RefPicList0[ num_ref_idx_l0_active_minus1 ] = currPic
```

When the slice is a B slice, the variable NumRpsCurrTempList1 is set equal to $\text{Max}(\text{num_ref_idx_l1_active_minus1} + 1, \text{NumPicTotalCurr})$ and the list RefPicListTemp1 is constructed as follows:

```
rIdx = 0
while( rIdx < NumRpsCurrTempList1 ) {
    for( i = 0; i < NumPocStCurrAfter && rIdx < NumRpsCurrTempList1; rIdx++, i++ )
        RefPicListTemp1[ rIdx ] = RefPicSetStCurrAfter[ i ]
    for( i = 0; i < NumActiveRefLayerPics1; rIdx++, i++ )
        RefPicListTemp1[ rIdx ] = RefPicSetInterLayer1[ i ]
    for( i = 0; i < NumPocStCurrBefore && rIdx < NumRpsCurrTempList1; rIdx++, i++ )           (F-67)
        RefPicListTemp1[ rIdx ] = RefPicSetStCurrBefore[ i ]
    for( i = 0; i < NumPocLtCurr && rIdx < NumRpsCurrTempList1; rIdx++, i++ )
        RefPicListTemp1[ rIdx ] = RefPicSetLtCurr[ i ]
    for( i = 0; i < NumActiveRefLayerPics0; rIdx++, i++ )
        RefPicListTemp1[ rIdx ] = RefPicSetInterLayer0[ i ]
    if( pps_curr_pic_ref_enabled_flag )
        RefPicListTemp1[ rIdx++ ] = currPic
}
```

When the slice is a B slice, the list RefPicList1 is constructed as follows:

```
for( rIdx = 0; rIdx <= num_ref_idx_l1_active_minus1; rIdx++ )                               (F-68)
    RefPicList1[ rIdx ] = ref_pic_list_modification_flag_l1 ? RefPicListTemp1[ list_entry_l1[ rIdx ] ] :
                                                                RefPicListTemp1[ rIdx ]
```

It is a requirement of bitstream conformance that when the current layer is an independent non-base layer, nal_unit_type has a value in the range of BLA_W_LP to RSV_IRAP_VCL23, inclusive (i.e. the picture is an IRAP picture), pps_curr_pic_ref_enabled_flag is equal to 1, and slice_type is not equal to 2,

RefPicList0 and RefPicList1 shall not contain entries that refer to a picture other than the current picture.

F.8.4 Decoding process for coding units coded in intra prediction mode

The specifications in 8.4 and its subclauses apply.

F.8.5 Decoding process for coding units coded in inter prediction mode

The specifications in 8.5 and its subclauses apply.

F.8.6 Scaling, transformation and array construction process prior to deblocking filter process

The specifications in 8.6 and its subclauses apply.

F.8.7 In-loop filter process

The specifications in 8.7 and its subclauses apply.

F.9 Parsing process

The specifications in Clause 9 and its subclauses apply.

F.10 Specification of bitstream subsets

F.10.1 Sub-bitstream extraction process

Inputs to this process are a bitstream `inBitstream`, a target highest TemporalId value `tIdTarget`, and a target layer identifier list `layerIdListTarget`.

Output of this process is a sub-bitstream `outBitstream`.

When `vps_base_layer_internal_flag` is equal to 1 and `vps_base_layer_available_flag` is equal to 1, it is a requirement of bitstream conformance for `inBitstream` that any output sub-bitstream `outBitstream` that is the output of the process specified in this clause with `inBitstream`, `tIdTarget` equal to any value in the range of 0 to 6, inclusive, and `layerIdListTarget` equal to the layer identifier list associated with a layer set specified in the active VPS as inputs, and that satisfies both of the following conditions shall be a conforming bitstream:

- The output sub-bitstream contains at least one VCL NAL unit with `nuh_layer_id` equal to each of the `nuh_layer_id` values in `layerIdListTarget`.
- The output sub-bitstream contains at least one VCL NAL unit with TemporalId equal to `tIdTarget`.

NOTE 1 When `vps_base_layer_internal_flag` is equal to 1 and `vps_base_layer_available_flag` is equal to 1, a conforming bitstream contains one or more coded slice segment NAL units with `nuh_layer_id` equal to 0 and TemporalId equal to 0.

The output sub-bitstream `outBitstream` is derived as follows:

- The bitstream `outBitstream` is set to be identical to the bitstream `inBitstream`.
- When one or more of the following two conditions are true, remove from `outBitstream` all SEI NAL units that have `nuh_layer_id` equal to 0 and that contain a non-nested buffering period SEI message, a non-nested picture timing SEI message, or a non-nested decoding unit information SEI message:
 - `layerIdListTarget` does not include all the values of `nuh_layer_id` in all NAL units in the bitstream.

ISO/IEC 23008-2:2017(E)

- `tidTarget` is less than the greatest `TemporalId` in all NAL units in the bitstream.

NOTE 2 A “smart” bitstream extractor may include appropriate non-nested buffering picture SEI messages, non-nested picture timing SEI messages, and non-nested decoding unit information SEI messages in the extracted sub-bitstream, provided that the SEI messages applicable to the sub-bitstream were present as nested SEI messages in the original bitstream.

- Remove from `outBitstream` all NAL units with `TemporalId` greater than `tidTarget` or `nuh_layer_id` not among the values included in `layerIdListTarget`.

F.10.2 Independent non-base layer rewriting process

Inputs to this process are a bitstream `inBitstream`, a target highest `TemporalId` value `tidTarget`, and a `nuh_layer_id` value `assignedBaseLayerId` of an independent non-base layer of an additional layer set.

Output of this process is a sub-bitstream `outBitstream`.

It is a requirement of bitstream conformance for `inBitstream` that any output sub-bitstream `outBitstream` that is the output of the process specified in this clause shall otherwise be a conforming bitstream except that `outBitstream` does not contain any VPS NAL units, when all of the following conditions apply:

- The output sub-bitstream `outBitstream` contains VCL NAL units with `nuh_layer_id` equal to `assignedBaseLayerId`.
- The value of `tidTarget` is equal to any value in the range of 0 to 6, inclusive, and `outBitstream` contains at least one VCL NAL unit with `TemporalId` equal to `tidTarget`.
- There is an OLS in the active VPS that consists of only the layer with `nuh_layer_id` equal to `assignedBaseLayerId`, the profile of that layer is a profile specified in Annex A, and the value of `general_inbld_flag` (when `tidTarget` is equal to `vps_max_sub_layers_minus1`) or the value of `sub_layer_inbld_flag[tidTarget]` (when `tidTarget` is less than `vps_max_sub_layers_minus1`) in the `profile_tier_level()` syntax structure associated with that layer is equal to 1.

The output sub-bitstream `outBitstream` is derived from the bitstream `inBitstream` as follows:

- The bitstream `outBitstream` is set to be identical to the bitstream `inBitstream`.
- NAL units with `nal_unit_type` not equal to `SPS_NUT`, `PPS_NUT`, and `EOB_NUT` and with `nuh_layer_id` not equal to the `assignedBaseLayerId` are removed from `outBitstream`.
- NAL units with `nal_unit_type` equal to `SPS_NUT` or `PPS_NUT` with `nuh_layer_id` not equal to 0 or `assignedBaseLayerId` are removed from `outBitstream`.
- NAL units with `nal_unit_type` equal to `VPS_NUT` are removed from `outBitstream`.
- All NAL units with `TemporalId` greater than `tidTarget` are removed from `outBitstream`.
- `nuh_layer_id` is set equal to 0 in each NAL unit of `outBitstream`.

F.10.3 Sub-bitstream extraction process for additional layer sets

Inputs to this process are a bitstream `inBitstream`, a target highest `TemporalId` value `tidTarget`, and a target layer identifier list `layerIdListTarget` of an additional layer set.

Output of this process is a sub-bitstream `outBitstream`.

It is a requirement of bitstream conformance for the input bitstream that the output sub-bitstream of the process specified in this subclause shall be a conforming bitstream according to at least one profile in which `vps_base_layer_available_flag` may be equal to 0, when all of the following conditions apply:

- The output sub-bitstream `outBitstream` contains VCL NAL units with each `nuh_layer_id` value in `layerIdListTarget`.
- The value of `tIdTarget` is equal to any value in the range of 0 to 6, inclusive, and `outBitstream` contains at least one VCL NAL unit with `TemporalId` equal to `tIdTarget`.
- `layerIdListTarget` is identical to `LayerSetLayerIdList[i]` for any value of `i` in the range of `FirstAddLayerSetIdx` to `LastAddLayerSetIdx`, inclusive.

The output sub-bitstream `outBitstream` is derived as follows:

- The bitstream `outBitstream` is set to be identical to the bitstream `inBitstream`.
- NAL units with `nal_unit_type` not equal to `VPS_NUT`, `SPS_NUT`, `PPS_NUT`, `EOS_NUT`, and `EOB_NUT` and with `nuh_layer_id` not equal to any value in `layerIdListTarget` are removed from `outBitstream`.
- NAL units with `nal_unit_type` equal to `VPS_NUT`, `SPS_NUT`, `PPS_NUT`, or `EOS_NUT` with `nuh_layer_id` not equal to 0 or any value in `layerIdListTarget` are removed from `outBitstream`.
- All NAL units with `TemporalId` greater than `tIdTarget` are removed from `outBitstream`.
- `vps_base_layer_available_flag` in each VPS is set equal to 0.

F.11 Profiles, tiers, and levels

F.11.1 Independent non-base layer decoding capability

This subclause specifies the independent non-base layer decoding (INBLD) capability, which is associated with the decoding capability of one or more of the profiles specified in Annex A. When expressing the capabilities of a decoder for one or more profiles specified in Annex A, whether the INBLD capability is supported for those profiles should also be expressed.

NOTE 1 The INBLD capability, when supported, indicates the capability of a decoder to decode an independent non-base layer that is indicated in the active VPSs and SPSs to conform to a profile specified in Annex A and is the layer with the smallest `nuh_layer_id` value in an additional layer set.

When the `profile_tier_level()` syntax structure is used for indicating of a decoder capability in systems, the INBLD capability may be indicated by setting the `general_inbld_flag` equal to 1 in the `profile_tier_level()` syntax structure used to express the profile, tier, and level that the decoder conforms to.

`general_inbld_flag` is set equal to 1 in the `profile_tier_level()` syntax structures in which a profile specified in Annex A is indicated and which are either specified in the VPS to be applicable for a non-base layer or included in an SPS activated for an independent non-base layer.

Decoders having the INBLD capability and conforming to a specific profile specified in Annex A at a specific level of a specific tier shall be capable of decoding any independent non-base layer or a sub-layer representation with `TemporalId` equal to `i` of the independent non-base layer for which all of the following condition applies for each active VPS:

- There is an OLS that consists of the independent non-base layer and for which the associated `profile_tier_level()` syntax structure `ptlStruct` is constrained as follows:
 - `ptlStruct` indicates that the independent non-base layer or the sub-layer representation conforms to a profile specified in Annex A.

- `ptlStruct` indicates that the independent non-base layer or the sub-layer representation conforms to a level lower than or equal to the specified level.
- `ptlStruct` indicates that the independent non-base layer or the sub-layer representation conforms to a tier lower than or equal to the specified tier.
- `general_inbld_flag` or `sub_layer_inbld_flag[i]` in `ptlStruct` is equal to 1.

NOTE 2 Let a derived bitstream `outBitstream` be a bitstream which is derived by invoking the independent non-base layer rewriting process specified in F.10.2 with a bitstream containing one or more independent non-base layers, `tidTarget` equal to 6, and `assignedBaseLayerId` equal to the smallest `nuh_layer_id` value of additional layer set as inputs. As specified elsewhere in this document, it is a requirement of bitstream conformance that `outBitstream` is otherwise a conforming bitstream but does not contain VPSs. Consequently, decoders with INBLD capability may apply the independent non-base layer rewriting process specified in F.10.2 to obtain `outBitstream` and then apply a decoding process for a profile specified in Annex A with `outBitstream` as input.

NOTE 3 The following constraints are necessary to ensure that a sub-bitstream derived by invoking the independent non-base layer rewriting process specified in F.10.2 conforms to a profile specified in Annex A:

- All active SPSs for the independent non-base layer have `nuh_layer_id` equal to 0 or `MultiLayerExtSpsFlag` equal to 0.
- Each active VPS has `poc_lsb_not_present_flag[i]` equal to 1 for each value of `i` for which `i` is the layer index of the independent non-base layer.

F.11.2 Decoder capabilities

This subclause specifies requirements for decoders having the capability of decoding an output operation point with one or more necessary layers.

NOTE For example, this clause specifies the requirements for a decoder supporting simultaneous decoding of the base layer and an independent non-base layer for which the INBLD capability is needed. Moreover, this subclause specifies the requirements for a decoder supporting decoding of layers conforming to profiles specified in Annex G or H.

A decoder that conforms to a list `ptliList` consisting of profile, tier, level and INBLD capability quadruplets (`Pi`, `Ti`, `Li`, `InbldFlagi`) for `i` in the range of 0 to `d - 1`, inclusive, where `d` is a positive integer, shall be capable of decoding any output operation point containing `b` necessary layers, where `b` is less than or equal to `d`, when the following condition applies:

- There exists a reordered list, `orderedPtliList`, of the profile, tier, level and INBLD capability quadruplets (`orderedPj`, `orderedTj`, `orderedLj`, `orderedInbldFlagj`) of the list `ptliList` such that all the following conditions apply for each value of `j` in the range of 0 to `b - 1`, inclusive, where the variable `bLayer[j]` represents the `j`-th necessary layer in the output operation point:
 - The profile to which `bLayer[j]` is indicated to conform is included in `CompatibleProfileList` for the profile `orderedPj` as specified in Table F.3.
 - The tier to which `bLayer[j]` is indicated to conform is lower than or equal to the tier `orderedTj`.
 - The level to which `bLayer[j]` is indicated to conform is lower than or equal to the level `orderedLj`.
 - When the profile to which `bLayer[j]` is indicated to conform is a profile specified in Annex A, the value of `general_inbld_flag` (when `OpTid` of the output operation point is equal to `vps_max_sub_layers_minus1`) or `sub_layer_inbld_flag[OpTid]` (when `OpTid` of the output operation point is less than `vps_max_sub_layers_minus1`) of `bLayer[j]` is less than or equal to `orderedInbldFlagj`.

For each particular format range extensions profile specified in A.3.5, the compatible format range extensions profiles are defined as the profiles that are indicated by both of the following conditions being true:

- The value of `general_profile_idc` is equal to 4 or `general_profile_compatibility_flag[4]` is equal to 1.
- The value of each constraint flag listed in Table A.2 is less than or equal to the corresponding value specified in the row in Table A.2 for the particular format range extensions profile.

For each particular scalable format range extensions profile specified in H.11.1.2, the compatible scalable format range extensions profiles are defined as the profiles that are indicated by all of the following conditions being true:

- The value of `general_profile_idc` is equal to 10 or `general_profile_compatibility_flag[10]` is equal to 1.
- The value of each constraint flag listed in Table H.4 is less than or equal to the corresponding value specified in the row of Table H.4 for the particular scalable format range extensions profile.

Table F.3 — Specification of CompatibleProfileList

Profile to which the decoder conforms	Profiles that the decoder shall support CompatibleProfileList
Scalable Main	Scalable Main, Main, Main Still Picture
Scalable Main 10	Scalable Main 10, Main, Main Still Picture, Main 10, Scalable Main
Scalable Monochrome	The compatible format range extensions profiles of the Monochrome profile, and the compatible scalable format range extensions profiles of the Scalable Monochrome profile
Scalable Monochrome 12	The compatible format range extensions profiles of the Monochrome 12 profile, and the compatible scalable format range extensions profiles of the Scalable Monochrome 12 profile
Scalable Monochrome 16	The compatible format range extensions profiles of the Monochrome 16 profile, and the compatible scalable format range extensions profiles of the Scalable Monochrome 16 profile
Scalable Main 4:4:4	Scalable Main, Main, Main Still Picture, the compatible format range extensions profiles of the Main 4:4:4 profile, and the compatible scalable format range extensions profiles of the Scalable Main 4:4:4 profile
Multiview Main	Multiview Main, Main, Main Still Picture
3D Main	3D Main, Multiview Main, Main Still Picture

F.11.3 Derivation of sub-bitstreams subBitstream and baseBitstream

For an output operation point associated with an OLS in a bitstream, let `olsIdx` be the OLS index of the OLS, the sub-bitstream `subBitstream` and base layer sub-bitstream `baseBitstream` are derived as follows:

- The sub-bitstream `subBitstream` is derived as follows:
 - If `OlsIdxToLsIdx[olsIdx]` is less than or equal to `vps_num_layer_sets_minus1`, `subBitstream` is derived by invoking the sub-bitstream extraction process as specified in F.10.1 with the

ISO/IEC 23008-2:2017(E)

following inputs: the bitstream, `tIdTarget` equal to `OpTid` of the output operation point, and `layerIdListTarget` containing the `nuh_layer_id` value `layerId` of the layer and all the reference layers of the layer.

- Otherwise, `subBitstream` is derived by invoking the sub-bitstream extraction process as specified in F.10.3 with `tIdTarget` equal to `OpTid` of the output operation point and with `layerIdListTarget` containing the `nuh_layer_id` value of the layer and all the reference layers of the layer.
- When `vps_base_layer_internal_flag` is equal to 1, the base layer sub-bitstream `baseBitstream` is derived as follows:
 - If VCL NAL units with `nuh_layer_id` equal to 0 are included in `subBitstream`, `baseBitstream` is derived by invoking the sub-bitstream extraction process as specified in F.10.1 with the `subBitstream`, `tIdTarget` equal to `OpTid` of the output operation point, and `layerIdListTarget` containing only one `nuh_layer_id` value that is equal to 0 as inputs.
 - Otherwise, `baseBitstream` is derived by invoking the independent non-base layer rewriting process as specified in F.10.2 with `subBitstream`, `tIdTarget` equal to `OpTid` of the output operation point, and `layerIdListTarget` containing only the smallest `nuh_layer_id` value of the VCL NAL units of `subBitstream` as inputs.

F.12 Byte stream format

The specifications in Annex B apply.

F.13 Hypothetical reference decoder

F.13.1 General

Three sets of bitstream conformance tests are needed for checking the conformance of a bitstream, which is referred to as the entire bitstream, denoted as `entireBitstream`. The first set of bitstream conformance tests are for testing the conformance of the entire bitstream and its temporal subsets, regardless of whether there is a layer set specified by the active VPS that contains all the `nuh_layer_id` values of VCL NAL units present in the entire bitstream. The second set of bitstream conformance tests are for testing the conformance of the layer sets specified by the active VPS and their temporal subsets. For all these tests, only the base layer pictures (i.e. pictures with `nuh_layer_id` equal to 0) are decoded and other pictures are ignored by the decoder when the decoding process is invoked.

The first and second sets of bitstream conformance tests are specified in C.1. F.13 and its subclauses specify the HRD operations for the third sets of bitstream conformance tests.

The third set of bitstream conformance tests are for testing the conformance of the OLSs specified by the VPS extension part of the active VPS and their temporal subsets. For each test in the third set of bitstream conformance tests, the following ordered steps apply in the order listed, followed by the processes described after these steps in this subclause:

1. An output operation point under test, denoted as `TargetOp`, is selected by selecting a value for `TargetOlsIdx` identifying a target OLS and selecting a target highest `TemporalId` value `HighestTid`. The value of `TargetOlsIdx` shall be in the range of 0 to `NumOutputLayerSets - 1`, inclusive, and the value of `HighestTid` shall be in the range of 0 to `MaxSubLayersInLayerSetMinus1[OlsIdxToLsIdx[TargetOlsIdx]]`, inclusive. Additionally, the values of `TargetOlsIdx` and `HighestTid` are constrained as specified in the next step.

The variables `TargetDecLayerSetIdx`, `TargetOptLayerIdList`, and `TargetDecLayerIdList` are then derived as specified in F.8.1.2. The output operation point under test has `OptLayerIdList` equal to

TargetOptLayerIdList, OpLayerIdList equal to TargetDecLayerIdList, and OpTid equal to HighestTid.

2. A bitstream to be decoded, BitstreamToDecode, is specified as follows:
 - If TargetDecLayerSetIdx is less than or equal to vps_num_layer_sets_minus1 and vps_base_layer_internal_flag is equal to 1, the sub-bitstream extraction process as specified in Clause 10 is applied with the bitstream entireBitstream, HighestTid, and TargetDecLayerIdList as inputs, and the output is assigned to BitstreamToDecode.
 - Otherwise, if TargetDecLayerSetIdx is less than or equal to vps_num_layer_sets_minus1 and vps_base_layer_internal_flag is equal to 0, the sub-bitstream extraction process as specified in F.10.1 is applied with the bitstream entireBitstream, HighestTid, and TargetDecLayerIdList as inputs, and the output is assigned to BitstreamToDecode.
 - Otherwise, if TargetDecLayerSetIdx is greater than vps_num_layer_sets_minus1, NumLayersInIdList[TargetDecLayerSetIdx] is equal to 1, and the profile of the layer in TargetOlsIdx is one of those specified in Annex A, the independent non-base layer rewriting process of F.10.2 is applied with the bitstream entireBitstream, HighestTid, and TargetDecLayerIdList[0] as inputs, and the output is assigned to BitstreamToDecode.
 - Otherwise, the sub-bitstream extraction process as specified in F.10.3 is applied with the bitstream entireBitstream, HighestTid, and TargetDecLayerIdList as inputs, and the output is assigned to BitstreamToDecode.

The values of TargetOlsIdx and HighestTid are additionally constrained as follows:

- When vps_base_layer_available_flag is equal to 0, OlsIdxToLsIdx[TargetOlsIdx] shall be in the range of FirstAddLayerSetIdx to LastAddLayerSetIdx, inclusive.
 - When vps_base_layer_internal_flag is equal to 0, TargetOlsIdx shall be greater than 0.
 - The value of TargetOlsIdx shall be such that there is at least one VCL NAL unit in BitstreamToDecode with nuh_layer_id equal to LayerSetLayerIdList[OlsIdxToLsIdx[TargetOlsIdx]][i] for each value of i in the range of 0 to NumLayersInIdList[OlsIdxToLsIdx[TargetOlsIdx]] - 1, inclusive.
 - The value of HighestTid shall be such there is at least one VCL NAL unit with TemporalId equal to HighestTid in BitstreamToDecode.
3. A partitioning scheme is selected from the list of partitioning schemes signalled in the active VPS for the selected OLS. The selected partitioning scheme is denoted as TargetPartitioningScheme with partitioning scheme index TargetPsIdx.
 4. The subsequent steps apply to each bitstream partition, referred to as the bitstream partition under test TargetBitstreamPartition, of the selected partitioning scheme of the target OLS. If there is only one bitstream partition for TargetPartitioningScheme, the TargetBitstreamPartition is identical to BitstreamToDecode. Otherwise, each bitstream partition is derived with the demultiplexing process for deriving a bitstream partition in F.13.6, with BitstreamToDecode, the list of layers in TargetBitstreamPartition, and the number of layers in TargetBitstreamPartition as inputs.
 5. The applicable hrd_parameters() syntax structures and the sub_layer_hrd_parameters() syntax structures are selected as follows:

- A SchedSelCombIdx is selected for BitstreamToDecode and used for each TargetBitstreamPartition. The selected SchedSelCombIdx shall be in the range of 0 to num_bsp_schedules_minus1[TargetOlsIdx][TargetPsIdx][HighestTid], inclusive.
- The applicable hrd_parameters() syntax structure is the bsp_hrd_idx[TargetOlsIdx][TargetPsIdx][HighestTid][SchedSelCombIdx][j]-th hrd_parameters() syntax structure in the active VPS, where j is the bitstream partition index of TargetBitstreamPartition.

Within the selected hrd_parameters() syntax structures, if BitstreamToDecode is a Type I bitstream, the sub_layer_hrd_parameters(HighestTid) syntax structures that immediately follow the condition "if(vcl_hrd_parameters_present_flag)" are selected and the variable NalHrdModeFlag is set equal to 0; otherwise (BitstreamToDecode is a Type II bitstream), the sub_layer_hrd_parameters(HighestTid) syntax structures that immediately follow either the condition "if(vcl_hrd_parameters_present_flag)" (in this case the variable NalHrdModeFlag is set equal to 0) or the condition "if(nal_hrd_parameters_present_flag)" (in this case the variable NalHrdModeFlag is set equal to 1) are selected. When BitstreamToDecode is a Type II bitstream and NalHrdModeFlag is equal to 0, all non-VCL NAL units except filler data NAL units, and all leading_zero_8bits, zero_byte, start_code_prefix_one_3bytes, and trailing_zero_8bits syntax elements that form a byte stream from the NAL unit stream (as specified in Annex B), when present, are discarded from TargetBitstreamPartition, and the remaining sub-bitstream is assigned to TargetBitstreamPartition.

6. An access unit associated with a buffering period SEI message (present in a bitstream partition nesting SEI message in BitstreamToDecode or available through external means not specified in this document) applicable to TargetOp, TargetPartitioningScheme, and TargetBitstreamPartition is selected as the HRD initialization point and referred to as access unit 0.

The variable MultiLayerCpbOperationFlag is derived as follows:

- If BitstreamToDecode contains only the base layer (i.e. TargetOlsIdx is equal to 0), MultiLayerCpbOperationFlag is set equal to 0.
 - Otherwise, MultiLayerCpbOperationFlag is set equal to 1.
7. If sub_pic_hrd_params_present_flag in the selected hrd_parameters() syntax structure is equal to 1, the CPB is scheduled to operate either at the partition unit level (in which case the variable SubPicHrdFlag is set equal to 0) or at the sub-partition level (in which case the variable SubPicHrdFlag is set equal to 1). Otherwise, SubPicHrdFlag is set equal to 0 and the CPB is scheduled to operate at the partition unit level.
 8. For each access unit in TargetBitstreamPartition starting from access unit 0, the buffering period SEI message (present in a bitstream partition nesting SEI message in BitstreamToDecode or available through external means not specified in this document) that is associated with the access unit and applies to TargetOp, TargetPartitioningScheme, and TargetBitstreamPartition is selected, the picture timing SEI message (present in a bitstream partition nesting SEI message in BitstreamToDecode or available through external means not specified in this document) that is associated with the access unit and applies to TargetOp, TargetPartitioningScheme, and TargetBitstreamPartition is selected, and when SubPicHrdFlag is equal to 1 and sub_pic_cpb_params_in_pic_timing_sei_flag is equal to 0, the decoding unit information SEI messages (present in bitstream partition nesting SEI messages in BitstreamToDecode or available through external means not specified in this document) that are associated with decoding units in the access unit and apply to TargetOp, TargetPartitioningScheme, and TargetBitstreamPartition are selected.

9. A value of SchedSelIdx for TargetBitstreamPartition is set equal to $\text{bsp_sched_idx}[\text{TargetOlsIdx}][\text{TargetPsIdx}][\text{HighestTid}][\text{SchedSelCombIdx}][j]$, where j is the index of the bitstream partition index of TargetBitstreamPartition.
10. The variable initialAltParamSelectionFlag is derived as follows:
- If all of the following conditions are true, initialAltParamSelectionFlag is set equal to 1:
 - The coded picture with nuh_layer_id equal to SmallestLayerId in access unit 0 has nal_unit_type equal to CRA_NUT or BLA_W_LP.
 - MultiLayerCpbOperationFlag is equal to 0.
 - irap_cpb_params_present_flag in the selected buffering period SEI message is equal to 1.
 - Otherwise, if all of the following conditions are true, initialAltParamSelectionFlag is set equal to 1:
 - The coded picture with nuh_layer_id equal to SmallestLayerId in access unit 0 is an IRAP picture.
 - MultiLayerCpbOperationFlag is equal to 1.
 - irap_cpb_params_present_flag in the selected buffering period SEI message is equal to 1.
 - Otherwise, initialAltParamSelectionFlag is set equal to 0.
11. When initialAltParamSelectionFlag is equal to 1, the following apply:
- The variable skippedPictureList is set to consist of the CL-RAS pictures and the RASL pictures associated with the IRAP pictures with nuh_layer_id equal to nuhLayerId for which LayerInitializedFlag[nuhLayerId] is equal to 0 at the start of decoding the IRAP picture and for which nuhLayerId is among TargetDecLayerIdList.
 - Either of the following apply for selection of the initial CPB removal delay and delay offset:
 - If NalHrdModeFlag is equal to 1, the default initial CPB removal delay and delay offset represented by nal_initial_cpb_removal_delay[SchedSelIdx] and nal_initial_cpb_removal_offset[SchedSelIdx], respectively, in the selected buffering period SEI message are selected. Otherwise, the default initial CPB removal delay and delay offset represented by vcl_initial_cpb_removal_delay[SchedSelIdx] and vcl_initial_cpb_removal_offset[SchedSelIdx], respectively, in the selected buffering period SEI message are selected. The variable DefaultInitCpbParamsFlag is set equal to 1.
 - If NalHrdModeFlag is equal to 0, the alternative initial CPB removal delay and delay offset represented by nal_initial_alt_cpb_removal_delay[SchedSelIdx] and nal_initial_alt_cpb_removal_offset[SchedSelIdx], respectively, in the selected buffering period SEI message are selected. Otherwise, the alternative initial CPB removal delay and delay offset represented by vcl_initial_alt_cpb_removal_delay[SchedSelIdx] and vcl_initial_alt_cpb_removal_offset[SchedSelIdx], respectively, in the selected buffering period SEI message are selected. The variable DefaultInitCpbParamsFlag is set equal to 0, and all the pictures in skippedPictureList are discarded from BitstreamToDecode and the remaining bitstream is assigned to BitstreamToDecode.

ISO/IEC 23008-2:2017(E)

Each conformance test consists of a combination of one option in each of the above steps. When there is more than one option for a step, for any particular conformance test only one option is chosen. All possible combinations of all the steps form the entire set of conformance tests.

When BitstreamToDecode is a Type II bitstream, the following apply:

- If the `sub_layer_hrd_parameters(HighestTid)` syntax structure that immediately follows the condition "`if(vcl_hrd_parameters_present_flag)`" is selected, the test is conducted at the Type I conformance point, and only VCL and filler data NAL units are counted for the input bit rate and CPB storage.
- Otherwise (the `sub_layer_hrd_parameters(HighestTid)` syntax structure that immediately follows the condition "`if(nal_hrd_parameters_present_flag)`" is selected), the test is conducted at the Type II conformance point, and all bytes of the Type II bitstream, which may be a NAL unit stream or a byte stream, are counted for the input bit rate and CPB storage.

NOTE 1 NAL HRD parameters established by a value of `SchedSelIdx` for the Type II conformance point are sufficient to also establish VCL HRD conformance for the Type I conformance point for the same values of `InitCpbRemovalDelay[SchedSelIdx]`, `BitRate[SchedSelIdx]`, and `CpbSize[SchedSelIdx]` for the VBR case (`cbr_flag[SchedSelIdx]` equal to 0). This is because the data flow into the Type I conformance point is a subset of the data flow into the Type II conformance point and because, for the VBR case, the CPB is allowed to become empty and stay empty until the time a next picture is scheduled to begin to arrive. For example, when decoding a CVS conforming to one or more of the profiles specified in Annex G using the decoding process specified in G.2 through G.10, when NAL HRD parameters are provided for the Type II conformance point that not only fall within the bounds set for NAL HRD parameters for profile conformance in item f) of G.11.2.2 but also fall within the bounds set for VCL HRD parameters for profile conformance in item e) of G.11.2.2, conformance of the VCL HRD for the Type I conformance point is also assured to fall within the bounds of item e) of G.11.2.2.

All VPSs, SPSs and PPSs referred to in the VCL NAL units, and the corresponding buffering period, picture timing and decoding unit information SEI messages shall be conveyed to the HRD, in a timely manner, either in the bitstream (by non-VCL NAL units), or by other means not specified in this document.

In Annexes C, D, and E, the specification for "presence" of non-VCL NAL units that contain VPSs, SPSs, PPSs, buffering period SEI messages, picture timing SEI messages, or decoding unit information SEI messages is also satisfied when those NAL units (or just some of them) are conveyed to decoders (or to the HRD) by other means not specified in this document. For the purpose of counting bits, only the appropriate bits that are actually present in the bitstream are counted.

NOTE 2 As an example, synchronization of such a non-VCL NAL unit, conveyed by means other than presence in the bitstream, with the NAL units that are present in the bitstream, can be achieved by indicating two points in the bitstream, between which the non-VCL NAL unit would have been present in the bitstream, had the encoder decided to convey it in the bitstream.

When the content of such a non-VCL NAL unit is conveyed for the application by some means other than presence within the bitstream, the representation of the content of the non-VCL NAL unit is not required to use the same syntax as specified in this document.

NOTE 3 When HRD information is contained within the bitstream, it is possible to verify the conformance of a bitstream to the requirements of this clause based solely on information contained in the bitstream. When the HRD information is not present in the bitstream, as is the case for all "stand-alone" Type I bitstreams, conformance can only be verified when the HRD data are supplied by some other means not specified in this document.

For the bitstream-partition-specific CPB operation as specified in this annex, the HRD contains a bitstream demultiplexer (optionally present), two or more bitstream partition buffers (BPB), two or more instantaneous decoding processes, a decoded picture buffer (DPB) that contains a sub-DPB for each layer, and output cropping as shown in Figure F.1.

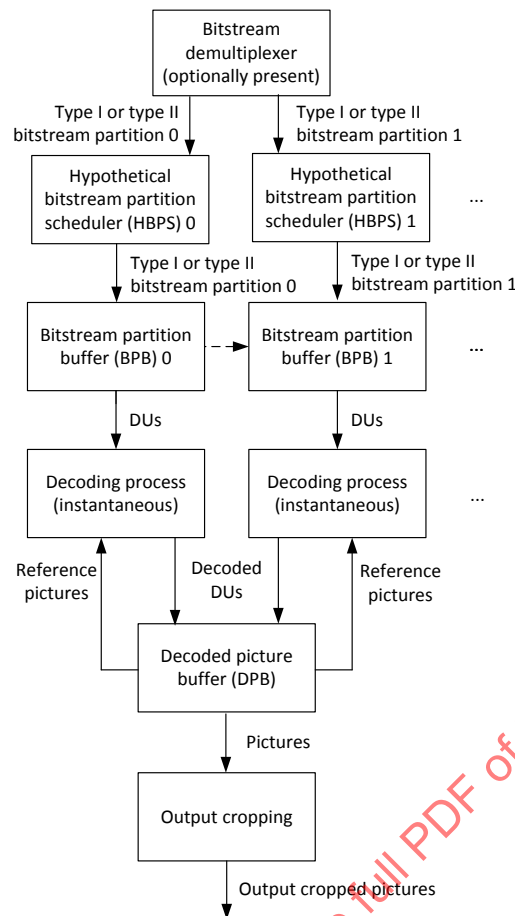

Figure F.1 — Bitstream-partition-specific HRD buffer model

For each bitstream conformance test, the size of BPB (or CPB) $CpbSize[SchedSelIdx]$ is $BpbSize[TargetOlsIdx][TargetPsIdx][HighestTid][SchedSelCombIdx][j]$, and the $BitRate[SchedSelIdx]$ is $BpBitRate[TargetOlsIdx][TargetPsIdx][HighestTid][SchedSelCombIdx][j]$, where j is the bitstream partition index of $TargetBitstreamPartition$, and $SchedSelIdx$ and the HRD parameters are specified above in this clause. The sub-DPB size of the sub-DPB for a layer with nuh_layer_id equal to $currLayerId$ is $max_vps_dec_pic_buffering_minus1[TargetOlsIdx][layerIdx][HighestTid] + 1$, where $layerIdx$ is equal to the value such that $LayerSetLayerIdList[TargetDeclayerSetIdx][layerIdx]$ is equal to $currLayerId$.

If $SubPicHrdFlag$ is equal to 0, the HRD operates at partition unit level and each decoding unit is a partition unit. Otherwise, the HRD operates at sub-partition level and each decoding unit is a subset of a partition unit.

NOTE 4 — If the HRD operates at partition unit level, each time when some bits are removed from the CPB, a decoding unit that is an entire partition unit is removed from the CPB. Otherwise (the HRD operates at sub-partition level), each time when some bits are removed from the CPB, a decoding unit that is a subset of a partition unit is removed from the CPB. Regardless of whether the HRD operates at partition unit level or sub-partition level, each time when some picture is output from the DPB, an entire decoded picture is output from the DPB, though the picture output time is derived based on the differently derived CPB removal times and the differently signalled DPB output delays.

The following is specified for expressing the constraints in this annex:

- Each access unit is referred to as access unit n , where the number n identifies the particular access unit. Access unit 0 is selected per step 6 above. The value of n is incremented by 1 for each subsequent access unit in decoding order.

ISO/IEC 23008-2:2017(E)

- Each decoding unit is referred to as decoding unit m , where the number m identifies the particular decoding unit. The first decoding unit in decoding order in access unit 0 is referred to as decoding unit 0. The value of m is incremented by 1 for each subsequent decoding unit in decoding order.

NOTE 5 The numbering of decoding units is relative to the first decoding unit in access unit 0.

- Picture n refers to a particular coded or decoded picture of access unit n .

The HRD operates as follows:

- The HRD is initialized at decoding unit 0, with the CPB, each sub-DPB of the DPB, and each BPB being set to be empty (the sub-DPB fullness for each sub-DPB is set equal to 0).

NOTE 6 After initialization, the HRD is not initialized again by subsequent buffering period SEI messages.

- Data associated with decoding units that flow into the BPB according to a specified arrival schedule are delivered by an HBPS.
- Each bitstream partition with index j is processed as specified in F.13.2 with the HSS replaced by the HBPS and with SchedSelIdx equal to $\text{bsp_sched_idx}[\text{TargetOlsIdx}][\text{TargetPsIdx}][\text{HighestTid}][\text{SchedSelCombIdx}][j]$.
- The data associated with each decoding unit are removed and decoded instantaneously by the instantaneous decoding process at the CPB removal time of the decoding unit.
- Each decoded picture is placed in the DPB.
- A decoded picture is removed from the DPB when it becomes no longer needed for inter prediction reference and no longer needed for output.

For each bitstream conformance test, the operation of the CPB and the BPB is specified in F.13.2, the instantaneous decoder operation is specified in Clauses 2 through 10, F.2 through F.10, and either G.2 through G.10 or H.2 through H.10, the operation of the DPB is specified in F.13.3, and the output cropping is specified in F.13.3.3 and F.13.5.2.2.

HSS, HBPS, and HRD information concerning the number of enumerated delivery schedules and their associated bit rates and buffer sizes is specified in E.2.2, E.2.3, F.7.3.2.1.6, and F.7.4.3.1.6. The HRD is initialized as specified by the buffering period SEI message specified in D.2.2 and D.3.2. The removal timing of decoding units from the CPB and output timing of decoded pictures from the DPB is specified using information in picture timing SEI messages (specified in D.2.3 and D.3.3) or in decoding unit information SEI messages (specified in D.2.22 and D.3.22). All timing information relating to a specific decoding unit shall arrive prior to the CPB removal time of the decoding unit.

The requirements for bitstream conformance are specified in F.13.4, and the HRD is used to check conformance of bitstreams as specified above in this subclause and to check conformance of decoders as specified in F.13.5.

F.13.2 Operation of bitstream partition buffer (BPB)

F.13.2.1 General

The specifications in this subclause apply independently to each set of BPB parameters that is present and to both the Type I and Type II conformance points, and the set of BPB parameters is selected as specified in F.13.1. In F.13.2 and its subclauses, CPB is understood to be BPB, and access unit is understood to be partition unit.

F.13.2.2 Timing of decoding unit arrival

The variable `altParamSelectionFlag` is derived as follows:

- If all of the following conditions are true, `altParamSelectionFlag` is set equal to 1:
 - The current picture is a BLA picture that has `nal_unit_type` equal to `BLA_W_LP` and `nuh_layer_id` equal to `SmallestLayerId` or is a CRA picture that has `nuh_layer_id` equal to `SmallestLayerId`.
 - `MultiLayerCpbOperationFlag` is equal to 0.
- Otherwise, if all of the following conditions are true, `altParamSelectionFlag` is set equal to 1:
 - The current picture is an IRAP picture with `nuh_layer_id` equal to `SmallestLayerId` and with `NoCldasOutputFlag` equal to 1.
 - `MultiLayerCpbOperationFlag` is equal to 1.
- Otherwise, `altParamSelectionFlag` is set equal to 0.

When `altParamSelectionFlag` is equal to 1, the following apply:

- If some external means not specified in this document is available to set the variable `UseAltCpbParamsFlag` to a value, `UseAltCpbParamsFlag` is set equal to the value provided by the external means.
- Otherwise, `UseAltCpbParamsFlag` is set equal to the value of `use_alt_cpb_params_flag` of the buffering period SEI message selected as specified in F.13.1.

If `SubPicHrdFlag` is equal to 0, the variable `subPicParamsFlag` is set equal to 0, and the process specified in the remainder of this clause is invoked with a decoding unit being considered as an access unit, for derivation of the initial and final CPB arrival times for access unit `n`.

Otherwise (`SubPicHrdFlag` is equal to 1), the process specified in the remainder of this clause is first invoked with the variable `subPicParamsFlag` set equal to 0 and a decoding unit being considered as an access unit, for derivation of the initial and final CPB arrival times for access unit `n`, and then invoked with `subPicParamsFlag` set equal to 1 and a decoding unit being considered as a subset of an access unit, for derivation of the initial and final CPB arrival times for the decoding units in access unit `n`.

The variables `InitCpbRemovalDelay[SchedSelIdx]` and `InitCpbRemovalDelayOffset[SchedSelIdx]` are derived as follows:

- If one or more of the following conditions are true, `InitCpbRemovalDelay[SchedSelIdx]` and `InitCpbRemovalDelayOffset[SchedSelIdx]` are set equal to the values of the buffering period SEI message syntax elements `nal_initial_alt_cpb_removal_delay[SchedSelIdx]` and `nal_initial_alt_cpb_removal_offset[SchedSelIdx]`, respectively, when `NalHrdModeFlag` is equal to 1, or `vcl_initial_alt_cpb_removal_delay[SchedSelIdx]` and `vcl_initial_alt_cpb_removal_offset[SchedSelIdx]`, respectively, when `NalHrdModeFlag` is equal to 0, where the buffering period SEI message syntax elements are selected as specified in F.13.1:
 - Access unit 0 includes a BLA picture with `nuh_layer_id` equal to `SmallestLayerId` and `nal_unit_type` equal to `BLA_W_RADL` or `BLA_N_LP`, `MultiLayerCpbOperationFlag` is equal to 0 and the value of `irap_cpb_params_present_flag` of the buffering period SEI message is equal to 1.
 - Access unit 0 includes a BLA picture with `nuh_layer_id` equal to `SmallestLayerId` and `nal_unit_type` equal to `BLA_W_LP` or includes a CRA picture with `nuh_layer_id` equal to

SmallestLayerId, MultiLayerCpbOperationFlag is equal to 0, and the value of irap_cpb_params_present_flag of the buffering period SEI message is equal to 1, and one or more of the following conditions are true:

- UseAltCpbParamsFlag for access unit 0 is equal to 1.
- DefaultInitCpbParamsFlag is equal to 0.
- Access unit 0 includes an IRAP picture with nuh_layer_id equal to SmallestLayerId, MultiLayerCpbOperationFlag is equal to 1 and the value of irap_cpb_params_present_flag of the buffering period SEI message is equal to 1, and one or more of the following conditions are true:
 - UseAltCpbParamsFlag for access unit 0 is equal to 1.
 - DefaultInitCpbParamsFlag is equal to 0.
- The value of subPicParamsFlag is equal to 1.
- Otherwise, InitCpbRemovalDelay[SchedSelIdx] and InitCpbRemovalDelayOffset[SchedSelIdx] are set equal to the values of the buffering period SEI message syntax elements nal_initial_cpb_removal_delay[SchedSelIdx] and nal_initial_cpb_removal_offset[SchedSelIdx], respectively, when NalHrdModeFlag is equal to 1, or vcl_initial_cpb_removal_delay[SchedSelIdx] and vcl_initial_cpb_removal_offset[SchedSelIdx], respectively, when NalHrdModeFlag is equal to 0, where the buffering period SEI message syntax elements are selected as specified in F.13.1.

The time at which the first bit of decoding unit m begins to enter the CPB is referred to as the initial arrival time $\text{initArrivalTime}[m]$.

Decoding units are indexed in decoding order within the bitstream.

The initial arrival time of decoding unit m is derived as follows:

- If the decoding unit is decoding unit 0 (i.e. when m is equal to 0) and the decoding unit belongs to the base bitstream partition, $\text{initArrivalTime}[0]$ is set equal to 0.
- Otherwise, if the decoding unit is decoding unit 0 and the decoding unit does not belong to the base bitstream partition, $\text{initArrivalTime}[0]$ is obtained from the bitstream partition initial arrival time SEI message that applies to TargetOp, TargetPartitioningScheme, and TargetBitstreamPartition and is associated with the access unit containing decoding unit 0. The applicable bitstream partition initial arrival time SEI message is either included in a bitstream partition nesting SEI message in an SEI NAL unit in the access unit containing decoding unit 0 in BitstreamToDecode or available through external means not specified in this document. If NalHrdModeFlag is equal to 0, $\text{initArrivalTime}[0]$ is set equal to $\text{vcl_initial_arrival_delay}[\text{SchedSelIdx}]$ in the applicable bitstream partition initial arrival time SEI message. Otherwise (NalHrdModeFlag is equal to 1), $\text{initArrivalTime}[0]$ is set equal to $\text{nal_initial_arrival_delay}[\text{SchedSelIdx}]$ in the applicable bitstream partition initial arrival time SEI message.
- Otherwise, the following apply:
 - If $\text{cbr_flag}[\text{SchedSelIdx}]$ is equal to 1, the initial arrival time for decoding unit m is equal to the final arrival time (which is derived below) of decoding unit $m - 1$, i.e.

$$\begin{aligned}
 &\text{if}(\text{!subPicParamsFlag}) \\
 &\quad \text{initArrivalTime}[m] = \text{AuFinalArrivalTime}[m - 1] \\
 &\text{else} \\
 &\quad \text{initArrivalTime}[m] = \text{DuFinalArrivalTime}[m - 1]
 \end{aligned}
 \tag{F-69}$$

- Otherwise ($\text{cbr_flag}[\text{SchedSelIdx}]$ is equal to 0), the initial arrival time for decoding unit m is derived as follows:

```

if( !subPicParamsFlag )
    initArrivalTime[ m ] = Max( AuFinalArrivalTime[ m - 1 ], initArrivalEarliestTime[ m ] ) (F-70)
else
    initArrivalTime[ m ] = Max( DuFinalArrivalTime[ m - 1 ], initArrivalEarliestTime[ m ] )

```

where $\text{initArrivalEarliestTime}[m]$ is derived as follows:

- The variable $\text{tmpNominalRemovalTime}$ is derived as follows:

```

if( !subPicParamsFlag )
    tmpNominalRemovalTime = AuNominalRemovalTime[ m ] (F-71)
else
    tmpNominalRemovalTime = DuNominalRemovalTime[ m ]

```

where $\text{AuNominalRemovalTime}[m]$ and $\text{DuNominalRemovalTime}[m]$ are the nominal CPB removal time of access unit m and decoding unit m , respectively, as specified in F.13.2.3.

- If decoding unit m is not the first decoding unit of a subsequent buffering period, $\text{initArrivalEarliestTime}[m]$ is derived as follows:

$$\text{initArrivalEarliestTime}[m] = \text{tmpNominalRemovalTime} - (\text{InitCpbRemovalDelay}[\text{SchedSelIdx}] + \text{InitCpbRemovalDelayOffset}[\text{SchedSelIdx}]) \div 90\,000 \quad (\text{F-72})$$

- Otherwise (decoding unit m is the first decoding unit of a subsequent buffering period), $\text{initArrivalEarliestTime}[m]$ is derived as follows:

$$\text{initArrivalEarliestTime}[m] = \text{tmpNominalRemovalTime} - (\text{InitCpbRemovalDelay}[\text{SchedSelIdx}] \div 90\,000) \quad (\text{F-73})$$

The final arrival time for decoding unit m is derived as follows:

```

if( !subPicParamsFlag )
    AuFinalArrivalTime[ m ] = initArrivalTime[ m ] + sizeInbits[ m ] ÷ BitRate[ SchedSelIdx ] (F-74)
else
    DuFinalArrivalTime[ m ] = initArrivalTime[ m ] + sizeInbits[ m ] ÷ BitRate[ SchedSelIdx ]

```

where $\text{sizeInbits}[m]$ is the size in bits of decoding unit m , counting the bits of the VCL NAL units and the filler data NAL units for the Type I conformance point or all bits of the Type II bitstream for the Type II conformance point.

The values of SchedSelIdx , $\text{BitRate}[\text{SchedSelIdx}]$, and $\text{CpbSize}[\text{SchedSelIdx}]$ are constrained as follows:

- If the lists of delivery schedules, including the HRD parameters associated with the individual delivery schedules, for the access unit containing decoding unit m and the previous access unit differ, the HSS selects a value SchedCombIdx1 in the range of 0 to $\text{num_bsp_schedules_minus1}[\text{TargetOlsIdx}][\text{TargetPsIdx}][\text{HighestTid}]$, inclusive, and sets SchedSelIdx1 for $\text{TargetBitstreamPartition}$ to be equal to $\text{bsp_sched_idx}[\text{TargetOlsIdx}][\text{TargetPsIdx}][\text{HighestTid}][\text{SchedSelCombIdx}][j]$, where j is the index of the bitstream partition index of $\text{TargetBitstreamPartition}$, for the access unit containing decoding unit m that results in a $\text{BitRate}[\text{SchedSelIdx1}]$ or $\text{CpbSize}[\text{SchedSelIdx1}]$ for the access unit containing decoding unit m . The value of $\text{BitRate}[\text{SchedSelIdx1}]$ or $\text{CpbSize}[\text{SchedSelIdx1}]$

may differ from the value of $\text{BitRate}[\text{SchedSelIdx0}]$ or $\text{CpbSize}[\text{SchedSelIdx0}]$ for the value SchedSelIdx0 of SchedSelIdx that was in use for the previous access unit.

- Otherwise, the HSS continues to operate with the previous values of SchedSelIdx , $\text{BitRate}[\text{SchedSelIdx}]$, and $\text{CpbSize}[\text{SchedSelIdx}]$.

When the HSS selects values of $\text{BitRate}[\text{SchedSelIdx}]$ or $\text{CpbSize}[\text{SchedSelIdx}]$ that differ from those of the previous access unit, the following apply:

- The variable $\text{BitRate}[\text{SchedSelIdx}]$ comes into effect at the initial CPB arrival time of the current access unit.
- The variable $\text{CpbSize}[\text{SchedSelIdx}]$ comes into effect as follows:
 - If the new value of $\text{CpbSize}[\text{SchedSelIdx}]$ is greater than the old CPB size, it comes into effect at the initial CPB arrival time of the current access unit.
 - Otherwise, the new value of $\text{CpbSize}[\text{SchedSelIdx}]$ comes into effect at the CPB removal time of the current access unit.

F.13.2.3 Timing of decoding unit removal and decoding of decoding unit

The variables $\text{InitCpbRemovalDelay}[\text{SchedSelIdx}]$, $\text{InitCpbRemovalDelayOffset}[\text{SchedSelIdx}]$, CpbDelayOffset , and DpbDelayOffset are derived as follows:

- If one or more of the following conditions are true, CpbDelayOffset is set equal to the value of the buffering period SEI message syntax element cpb_delay_offset , DpbDelayOffset is set equal to the value of the buffering period SEI message syntax element dpb_delay_offset , and $\text{InitCpbRemovalDelay}[\text{SchedSelIdx}]$ and $\text{InitCpbRemovalDelayOffset}[\text{SchedSelIdx}]$ are set equal to the values of the buffering period SEI message syntax elements $\text{nal_initial_alt_cpb_removal_delay}[\text{SchedSelIdx}]$ and $\text{nal_initial_alt_cpb_removal_offset}[\text{SchedSelIdx}]$, respectively, when NalHrdModeFlag is equal to 1, or $\text{vcl_initial_alt_cpb_removal_delay}[\text{SchedSelIdx}]$ and $\text{vcl_initial_alt_cpb_removal_offset}[\text{SchedSelIdx}]$, respectively, when NalHrdModeFlag is equal to 0, where the buffering period SEI message containing the syntax elements is selected as specified in F.13.1:
 - Access unit 0 includes a BLA picture with nuh_layer_id equal to SmallestLayerId and nal_unit_type equal to BLA_W_RADL or BLA_N_LP , $\text{MultiLayerCpbOperationFlag}$ is equal to 0 and the value of $\text{irap_cpb_params_present_flag}$ of the buffering period SEI message is equal to 1.
 - Access unit 0 includes a BLA picture with nuh_layer_id equal to SmallestLayerId and nal_unit_type equal to BLA_W_LP or includes a CRA picture with nuh_layer_id equal to SmallestLayerId , $\text{MultiLayerCpbOperationFlag}$ is equal to 0 and the value of $\text{irap_cpb_params_present_flag}$ of the buffering period SEI message is equal to 1, and one or more of the following conditions are true:
 - $\text{UseAltCpbParamsFlag}$ for access unit 0 is equal to 1.
 - $\text{DefaultInitCpbParamsFlag}$ is equal to 0.
 - Access unit 0 includes an IRAP picture with nuh_layer_id equal to SmallestLayerId , $\text{MultiLayerCpbOperationFlag}$ is equal to 1 and the value of $\text{irap_cpb_params_present_flag}$ of the buffering period SEI message is equal to 1, and one or more of the following conditions are true:

- UseAltCpbParamsFlag for access unit 0 is equal to 1.
- DefaultInitCpbParamsFlag is equal to 0.
- Otherwise, InitCpbRemovalDelay[SchedSelIdx] and InitCpbRemovalDelayOffset[SchedSelIdx] are set equal to the values of the buffering period SEI message syntax elements nal_initial_cpb_removal_delay[SchedSelIdx] and nal_initial_cpb_removal_offset[SchedSelIdx], respectively, when NalHrdModeFlag is equal to 1, or vcl_initial_cpb_removal_delay[SchedSelIdx] and vcl_initial_cpb_removal_offset[SchedSelIdx], respectively, when NalHrdModeFlag is equal to 0, where the buffering period SEI message containing the syntax elements is selected as specified in F.13.1, CpbDelayOffset and DpbDelayOffset are both set equal to 0.

The nominal removal time of the access unit n from the CPB is specified as follows:

- If access unit n is the access unit with n equal to 0 (the access unit that initializes the HRD), the nominal removal time of the access unit from the CPB is specified by:

$$\text{AuNominalRemovalTime}[0] = \text{InitCpbRemovalDelay}[\text{SchedSelIdx}] \div 90\,000 \quad (\text{F-75})$$

- Otherwise, the following apply:

- When access unit n is the first access unit of a buffering period that does not initialize the HRD, the following applies:

The nominal removal time of the access unit n from the CPB is specified by:

$$\begin{aligned} & \text{if} (\text{!concatenationFlag}) \{ \\ & \quad \text{baseTime} = \text{AuNominalRemovalTime}[\text{firstPicInPrevBuffPeriod}] \\ & \quad \text{tmpCpbRemovalDelay} = \text{AuCpbRemovalDelayVal} \\ & \} \text{ else } \{ \\ & \quad \text{baseTime} = \text{AuNominalRemovalTime}[\text{prevNonDiscardablePic}] \\ & \quad \text{tmpCpbRemovalDelay} = \\ & \quad \quad \text{Max}([\text{auCpbRemovalDelayDeltaMinus1} + 1] , \\ & \quad \quad \text{Ceil}([\text{InitCpbRemovalDelay}[\text{SchedSelIdx}] \div 90000 + \\ & \quad \quad \text{AuFinalArrivalTime}[n - 1] - \text{AuNominalRemovalTime}[n - 1]] \div \text{ClockTick})) \\ & \} \\ & \text{AuNominalRemovalTime}[n] = \text{baseTime} + \text{ClockTick} * (\text{tmpCpbRemovalDelay} - \\ & \quad \text{CpbDelayOffset}) \end{aligned} \quad (\text{F-76})$$

where $\text{AuNominalRemovalTime}[\text{firstPicInPrevBuffPeriod}]$ is the nominal removal time of the first access unit of the previous buffering period, $\text{AuNominalRemovalTime}[\text{prevNonDiscardablePic}]$ is the nominal removal time of the preceding access unit in decoding order, each picture of which is with TemporalId equal to 0 that is not a RASL, RADL, or SLNR picture, $\text{AuCpbRemovalDelayVal}$ is the value of $\text{AuCpbRemovalDelayVal}$ derived according to $\text{au_cpb_removal_delay_minus1}$ in the picture timing SEI message, selected as specified in F.13.1, associated with access unit n, and concatenationFlag and $\text{auCpbRemovalDelayDeltaMinus1}$ are the values of the syntax elements $\text{concatenation_flag}$ and $\text{au_cpb_removal_delay_delta_minus1}$, respectively, in the buffering period SEI message, selected as specified in F.13.1, associated with access unit n.

After the derivation of the nominal CPB removal time and before the derivation of the DPB output time of access unit n, the values of CpbDelayOffset and DpbDelayOffset are updated as follows:

- If one or more of the following conditions are true, CpbDelayOffset is set equal to the value of the buffering period SEI message syntax element cpb_delay_offset, and DpbDelayOffset is set equal to the value of the buffering period SEI message syntax element dpb_delay_offset, where the buffering period SEI message containing the syntax elements is selected as specified in F.13.1:
 - Access unit n includes a BLA picture with nuh_layer_id equal to SmallestLayerId and nal_unit_type equal to BLA_W_RADL or BLA_N_LP, MultiLayerCpbOperationFlag is equal to 0 and the value of irap_cpb_params_present_flag of the buffering period SEI message is equal to 1.
 - Access unit n includes a BLA picture with nuh_layer_id equal to SmallestLayerId and nal_unit_type equal to BLA_W_LP or includes a CRA picture with nuh_layer_id equal to SmallestLayerId, MultiLayerCpbOperationFlag is equal to 0, the value of irap_cpb_params_present_flag of the buffering period SEI message is equal to 1, and UseAltCpbParamsFlag for access unit n is equal to 1.
 - Access unit n includes an IRAP picture with nuh_layer_id equal to SmallestLayerId, MultiLayerCpbOperationFlag is equal to 1, the value of irap_cpb_params_present_flag of the buffering period SEI message is equal to 1, and UseAltCpbParamsFlag for access unit n is equal to 1.
 - Otherwise, CpbDelayOffset and DpbDelayOffset are both set equal to 0.
- When access unit n is not the first access unit of a buffering period, the nominal removal time of the access unit n from the CPB is specified by:

$$\text{AuNominalRemovalTime}[n] = \text{AuNominalRemovalTime}[\text{firstPicInCurrBuffPeriod}] + \text{ClockTick} * (\text{AuCpbRemovalDelayVal} - \text{CpbDelayOffset}) \quad (\text{F-77})$$

where AuNominalRemovalTime[firstPicInCurrBuffPeriod] is the nominal removal time of the first access unit of the current buffering period, and AuCpbRemovalDelayVal is the value of AuCpbRemovalDelayVal derived according to au_cpb_removal_delay_minus1 in the picture timing SEI message, selected as specified in F.13.1, associated with access unit n.

When SubPicHrdFlag is equal to 1, the following apply:

- The variable duCpbRemovalDelayInc is derived as follows:
 - If sub_pic_cpb_params_in_pic_timing_sei_flag is equal to 0, duCpbRemovalDelayInc is set equal to the value of du_spt_cpb_removal_delay_increment in the decoding unit information SEI message, selected as specified in F.13.1, associated with decoding unit m.
 - Otherwise, if du_common_cpb_removal_delay_flag is equal to 0, duCpbRemovalDelayInc is set equal to the value of du_cpb_removal_delay_increment_minus1[i] + 1 for decoding unit m in the picture timing SEI message, selected as specified in F.13.1, associated with access unit n, where the value of i is 0 for the first num_nalus_in_du_minus1[0] + 1 consecutive NAL units in the access unit that contains decoding unit m, 1 for the subsequent num_nalus_in_du_minus1[1] + 1 NAL units in the same access unit, 2 for the subsequent num_nalus_in_du_minus1[2] + 1 NAL units in the same access unit, etc.
 - Otherwise, duCpbRemovalDelayInc is set equal to the value of du_common_cpb_removal_delay_increment_minus1 + 1 in the picture timing SEI message, selected as specified in F.13.1, associated with access unit n.
- The nominal removal time of decoding unit m from the CPB is specified as follows, where AuNominalRemovalTime[n] is the nominal removal time of access unit n:

- If decoding unit m is the last decoding unit in access unit n , the nominal removal time of decoding unit m $DuNominalRemovalTime[m]$ is set equal to $AuNominalRemovalTime[n]$.
- Otherwise (decoding unit m is not the last decoding unit in access unit n), the nominal removal time of decoding unit m $DuNominalRemovalTime[m]$ is derived as follows:

$$\begin{aligned} & \text{if(sub_pic_cpb_params_in_pic_timing_sei_flag)} \\ & \quad DuNominalRemovalTime[m] = DuNominalRemovalTime[m + 1] - \\ & \quad \quad ClockSubTick * duCpbRemovalDelayInc \qquad \qquad \qquad (F-78) \\ & \text{else} \\ & \quad DuNominalRemovalTime[m] = AuNominalRemovalTime[n] - \\ & \quad \quad ClockSubTick * duCpbRemovalDelayInc \end{aligned}$$

If $SubPicHrdFlag$ is equal to 0, the removal time of access unit n from the CPB is specified as follows, where $AuFinalArrivalTime[n]$ and $AuNominalRemovalTime[n]$ are the final CPB arrival time and nominal CPB removal time, respectively, of access unit n :

$$\begin{aligned} & \text{if(!low_delay_hrd_flag[HighestTid] || AuNominalRemovalTime[n] >= AuFinalArrivalTime[n])} \\ & \quad AuCpbRemovalTime[n] = AuNominalRemovalTime[n] \\ & \text{else} \qquad \qquad \qquad (F-79) \\ & \quad AuCpbRemovalTime[n] = AuNominalRemovalTime[n] + ClockTick * \\ & \quad \quad Ceil((AuFinalArrivalTime[n] - AuNominalRemovalTime[n]) \div ClockTick) \end{aligned}$$

NOTE 1 When $low_delay_hrd_flag[HighestTid]$ is equal to 1 and $AuNominalRemovalTime[n]$ is less than $AuFinalArrivalTime[n]$, the size of access unit n is so large that it prevents removal at the nominal removal time.

Otherwise ($SubPicHrdFlag$ is equal to 1), the removal time of decoding unit m from the CPB is specified as follows:

- The following applies:

$$\begin{aligned} & \text{if(!low_delay_hrd_flag[HighestTid] || DuNominalRemovalTime[m] >= DuFinalArrivalTime[m])} \\ & \quad DuCpbRemovalTime[m] = DuNominalRemovalTime[m] \qquad \qquad \qquad (F-80) \\ & \text{else} \\ & \quad DuCpbRemovalTime[m] = DuFinalArrivalTime[m] \end{aligned}$$

NOTE 2 When $low_delay_hrd_flag[HighestTid]$ is equal to 1 and $DuNominalRemovalTime[m]$ is less than $DuFinalArrivalTime[m]$, the size of decoding unit m is so large that it prevents removal at the nominal removal time.

- When $cbr_flag[SchedSelIdx]$ is equal to 0, the following apply:

- Let $refDuCpbRemovalTime$ be equal to the CPB removal time of the previous DU preceding the current DU in decoding order (regardless of the bitstream partitions to which the previous DU and the current DU belong).

- The variable $DuCpbRemovalTime[m]$ is modified as follows:

$$DuCpbRemovalTime[m] = \text{Max}(DuCpbRemovalTime[m], refDuCpbRemovalTime) \qquad \qquad \qquad (F-81)$$

If $SubPicHrdFlag$ is equal to 0, at the CPB removal time of access unit n , the access unit is instantaneously decoded.

Otherwise ($SubPicHrdFlag$ is equal to 1), at the CPB removal time of decoding unit m , the decoding unit is instantaneously decoded, and when decoding unit m is the last decoding unit of access unit n , the following apply:

- Access unit n is considered as decoded.

ISO/IEC 23008-2:2017(E)

- The final CPB arrival time of access unit n , i.e. $AuFinalArrivalTime[n]$, is set equal to the final CPB arrival time of the last decoding unit in access unit n , i.e. $DuFinalArrivalTime[m]$.
- The nominal CPB removal time of access unit n , i.e. $AuNominalRemovalTime[n]$, is set equal to the nominal CPB removal time of the last decoding unit in access unit n , i.e. $DuNominalRemovalTime[m]$.
- The CPB removal time of access unit n , i.e. $AuCpbRemovalTime[m]$, is set equal to the CPB removal time of the last decoding unit in access unit n , i.e. $DuCpbRemovalTime[m]$.

F.13.3 Operation of decoded picture buffer (DPB)

F.13.3.1 General

The specifications in this subclause apply independently to each set of DPB parameters selected as specified in F.13.1.

The decoded picture buffer consists of sub-DPBs, and each sub-DPB contains picture storage buffers for storage of decoded pictures of one layer. Each of the picture storage buffers of a sub-DPB may contain a decoded picture that is marked as “used for reference” or is held for future output.

The processes specified in F.13.3.2, F.13.3.3, F.13.3.4, and F.13.3.5 are sequentially applied as specified below, and are applied independently for each layer, starting from the base layer, in increasing order of nuh_layer_id values of the layers in the bitstream. When these processes are applied for a particular layer, only the sub-DPB for the particular layer is affected. In the descriptions of these processes, the DPB refers to the sub-DPB for the particular layer, and the particular layer is referred to as the current layer.

NOTE In the operation of output timing DPB, decoded pictures with $PicOutputFlag$ equal to 1 in the same access unit are output consecutively in ascending order of the nuh_layer_id values of the decoded pictures.

Let picture n and the current picture be the coded picture or decoded picture of the access unit n for a particular value of nuh_layer_id , wherein n is a non-negative integer number.

F.13.3.2 Removal of pictures from the DPB before decoding of the current picture

When the current picture is not picture 0 in the current layer, the removal of pictures in the current layer, with nuh_layer_id equal to $currLayerId$, from the DPB before decoding of the current picture, i.e. picture n , but after parsing the slice header of the first slice of the current picture, happens instantaneously at the CPB removal time of the first decoding unit of the current picture and proceeds as follows:

- The decoding process for RPS as specified in F.8.3.2 is invoked.
- The variable $listOfSubDpbsToEmpty$ is derived as follows:
 - If a new VPS is activated by the current access unit or the current picture is an IRAP picture with nuh_layer_id equal to $SmallestLayerId$, $NoRaslOutputFlag$ equal to 1, and $NoCllasOutputFlag$ equal to 1, $listOfSubDpbsToEmpty$ is set to include all the sub-DPBs.
 - Otherwise, if the current picture is an IRAP picture with any nuh_layer_id value $indepLayerId$ such that $NumDirectRefLayers[indepLayerId]$ is equal to 0 and $indepLayerId$ is greater than $SmallestLayerId$, and with $NoRaslOutputFlag$ equal to 1, and $LayerResetFlag$ equal to 1, $listOfSubDpbsToEmpty$ is set equal to the sub-DPBs containing the current layer and the sub-DPBs containing the predicted layers of the current layer.
 - Otherwise, $listOfSubDpbsToEmpty$ is set equal to the sub-DPB containing the current layer.

- When the current picture is an IRAP picture with NoRaslOutputFlag equal to 1 and any of the following conditions is true:
 - nuh_layer_id equal to SmallestLayerId,
 - nuh_layer_id of the current layer is greater than SmallestLayerId, and NumDirectRefLayers[nuh_layer_id] is equal to 0, the following ordered steps are applied:
 1. The variable NoOutputOfPriorPicsFlag is derived for the decoder under test as follows:
 - If the current picture is a CRA picture, NoOutputOfPriorPicsFlag is set equal to 1 (regardless of the value of no_output_of_prior_pics_flag).
 - Otherwise, if the value of pic_width_in_luma_samples, pic_height_in_luma_samples, chroma_format_idc, bit_depth_luma_minus8, bit_depth_chroma_minus8, separate_colour_plane_flag, or sps_max_dec_pic_buffering_minus1[HighestTid] derived from the active SPS for the current layer is different from the value of pic_width_in_luma_samples, pic_height_in_luma_samples, chroma_format_idc, bit_depth_luma_minus8, bit_depth_chroma_minus8, separate_colour_plane_flag, or sps_max_dec_pic_buffering_minus1[HighestTid], respectively, derived from the SPS that was active for the current layer when decoding the preceding picture in the current layer, NoOutputOfPriorPicsFlag may (but should not) be set equal to 1 by the decoder under test, regardless of the value of no_output_of_prior_pics_flag.
- NOTE Although setting NoOutputOfPriorPicsFlag equal to no_output_of_prior_pics_flag is preferred under these conditions, the decoder under test is allowed to set NoOutputOfPriorPicsFlag to 1 in this case.
- Otherwise, NoOutputOfPriorPicsFlag is set equal to no_output_of_prior_pics_flag.
2. When the value of NoOutputOfPriorPicsFlag derived for the decoder under test is equal to 1, all non-empty picture storage buffers in all the sub-DPBs contained in listOfSubDpbsToEmpty are emptied without output of the pictures they contain, and the sub-DPB fullness of each sub-DPB in listOfSubDpbsToEmpty is set equal to 0.
- When both of the following conditions are true for any pictures k in the DPB, all such pictures k in the DPB are removed from the DPB:
 - picture k is marked as “unused for reference”;
 - picture k has PicOutputFlag equal to 0 or its DPB output time is less than or equal to the CPB removal time of the first decoding unit (denoted as decoding unit m) of the current picture n; i.e. DpbOutputTime[k] is less than or equal to CpbRemovalTime(m).
 - For each picture that is removed from the DPB, the DPB fullness is decremented by one.

F.13.3.3 Picture output

The processes specified in this clause happen instantaneously at the CPB removal time of access unit n, AuCpbRemovalTime[n].

When access unit n has AuOutputFlag equal to 1, its DPB output time DpbOutputTime[n] is derived as follows, where the variable firstPicInBufferingPeriodFlag is equal to 1 if access unit n is the first access unit of a buffering period and 0 otherwise:

$$\begin{aligned} &\text{if(!SubPicHrdFlag) } \{ \\ &\quad \text{DpbOutputTime[n]} = \text{AuCpbRemovalTime[n]} + \text{ClockTick} * \text{picDpbOutputDelay} \quad (\text{F-82}) \\ &\quad \text{if(firstPicInBufferingPeriodFlag)} \end{aligned}$$

```

        DpbOutputTime[ n ] -= ClockTick * DpbDelayOffset
    } else
        DpbOutputTime[ n ] = AuCpbRemovalTime[ n ] + ClockSubTick * picSptDpbOutputDuDelay

```

where `picDpbOutputDelay` is the value of `pic_dpb_output_delay` in the picture timing SEI message associated with access unit `n`, and `picSptDpbOutputDuDelay` is the value of `pic_spt_dpb_output_du_delay`, when present, in the decoding unit information SEI messages associated with access unit `n`, or the value of `pic_dpb_output_du_delay` in the picture timing SEI message associated with access unit `n` when there is no decoding unit information SEI message associated with access unit `n` or no decoding unit information SEI message associated with access unit `n` has `pic_spt_dpb_output_du_delay` present.

NOTE When the syntax element `pic_spt_dpb_output_du_delay` is not present in any decoding unit information SEI message associated with access unit `n`, the value is inferred to be equal to `pic_dpb_output_du_delay` in the picture timing SEI message associated with access unit `n`.

The output of the current picture contained in access unit `n` is specified as follows:

- If `PicOutputFlag` is equal to 1 and `DpbOutputTime[n]` is equal to `AuCpbRemovalTime[n]`, the current picture is output.
- Otherwise, if `PicOutputFlag` is equal to 0, the current picture is not output, but will be stored in the DPB as specified in F.13.3.4.
- Otherwise (`PicOutputFlag` is equal to 1 and `DpbOutputTime[n]` is greater than `AuCpbRemovalTime[n]`), the current picture is output later and will be stored in the DPB (as specified in F.13.3.4) and is output at time `DpbOutputTime[n]` unless indicated not to be output by the decoding or inference of `NoOutputOfPriorPicsFlag` equal to 1 at a time that precedes `DpbOutputTime[n]`.

When output, a picture is cropped using the conformance cropping window specified in the active SPS for the layer containing the picture.

When access unit `n` is an access unit that has `AuOutputFlag` equal to 1 and is not the last access unit of the bitstream that has `AuOutputFlag` equal to 1, the value of the variable `DpbOutputInterval[n]` is derived as follows:

$$DpbOutputInterval[n] = DpbOutputTime[nextAuInOutputOrder] - DpbOutputTime[n] \quad (F-83)$$

where `nextAuInOutputOrder` is the access unit that follows access unit `n` in output order and has `AuOutputFlag` equal to 1.

F.13.3.4 Current decoded picture marking and storage

The current decoded picture after the invocation of the in-loop filter process as specified in F.8.7 is stored in the DPB in an empty picture storage buffer, the DPB fullness is incremented by one, and this picture is marked as “used for short-term reference”.

When `TwoVersionsOfCurrDecPicFlag` is equal to 1, the current decoded picture before the invocation of the in-loop filter process as specified in F.8.7 is stored in the DPB in an empty picture storage buffer, the DPB fullness is incremented by one, and this picture is marked as “used for long-term reference”.

NOTE Unless more memory than required by the level limit is available for storage of decoded pictures, decoders are expected to start storing decoded parts of the current picture into the DPB when the first slice segment is decoded and continue storing more decoded samples as the decoding process proceeds.

F.13.3.5 Removal of pictures from the DPB after decoding of the current picture

When `TwoVersionsOfCurrDecPicFlag` is equal to 1, immediately after decoding of the current picture, at the CPB removal time of the last decoding unit of access unit `n` (containing the current picture), the current decoded picture that is marked as "used for long-term reference" is removed from the DPB, and the DPB fullness is decremented by one.

F.13.4 Bitstream conformance

A bitstream of coded data conforming to this document shall fulfil all requirements specified in this subclause.

The bitstream shall be constructed according to the syntax, semantics, and constraints specified in this document outside of this annex.

The first access unit in a bitstream shall be an IRAP access unit.

When `vps_base_layer_internal_flag` is equal to 0, all the following bitstream conformance constraints apply only to coded pictures present in the bitstream, and do not apply to pictures with `nuh_layer_id` equal to 0 which are provided by external means.

Let `currPicLayerId` be equal to the `nuh_layer_id` of the current picture.

For each current picture, let the variables `maxPicOrderCnt` and `minPicOrderCnt` be set equal to the maximum and the minimum, respectively, of the `PicOrderCntVal` values of the following pictures with `nuh_layer_id` equal to `currPicLayerId`:

- The current picture.
- The previous picture in decoding order that has `TemporalId` equal to 0 and that is not a RASL, RADL, or SLNR picture.
- The short-term reference pictures in the RPS of the current picture.
- All pictures `m` that have `PicOutputFlag` equal to 1, `AuCpbRemovalTime[m]` less than `AuCpbRemovalTime[currAu]`, and `DpbOutputTime[m]` greater than or equal to `AuCpbRemovalTime[currAu]`, where `currAu` is the access unit containing the current picture, and `AuCpbRemovalTime[m]` and `DpbOutputTime[m]` are the CPB removal time and the DPB output time, respectively, of the access unit containing picture `m`.

The bitstream and the sub-bitstream of each output layer set are tested by the HRD for conformance as specified in C.1 and F.13.1. All the conditions specified in C.4 shall be fulfilled for each of the first and second sets of conformance tests. All of the following conditions shall be fulfilled for each of the third set of conformance tests:

1. For each partition unit `n`, with `n` greater than 0, associated with a buffering period SEI message, let the variable `deltaTime90k[n]` be specified as follows:

$$\text{deltaTime90k}[n] = 90\,000 * (\text{AuNominalRemovalTime}[n] - \text{AuFinalArrivalTime}[n - 1]) \quad (\text{F-84})$$

The value of `InitCpbRemovalDelay[SchedSelIdx]` is constrained as follows:

- If `cbr_flag[SchedSelIdx]` is equal to 0, the following condition shall be true:

$$\text{InitCpbRemovalDelay}[\text{SchedSelIdx}] \leq \text{Ceil}(\text{deltaTime90k}[n]) \quad (\text{F-85})$$

- Otherwise (`cbr_flag[SchedSelIdx]` is equal to 1), the following condition shall be true:

$$\begin{aligned} \text{Floor}(\text{deltaTime90k}[n]) &\leq \text{InitCpbRemovalDelay}[\text{SchedSelIdx}] \\ &\leq \text{Ceil}(\text{deltaTime90k}[n]) \end{aligned} \quad (\text{F-86})$$

ISO/IEC 23008-2:2017(E)

NOTE 1 The exact number of bits in the BPB at the removal time of each partition unit can depend on which buffering period SEI message is selected to initialize the HRD. Encoders need to take this into account to ensure that all specified constraints are obeyed regardless of which buffering period SEI message is selected to initialize the HRD, as the HRD could be initialized at any one of the buffering period SEI messages.

2. A BPB overflow is specified as the condition in which the total number of bits in the BPB is greater than the BPB size. The BPB shall never overflow.
3. A BPB underflow is specified as the condition in which the nominal BPB removal time of decoding unit m $DuNominalRemovalTime(m)$ is less than the final BPB arrival time of decoding unit m $DuFinalArrivalTime(m)$ for at least one value of m . When $low_delay_hrd_flag[HighestTid]$ is equal to 0, the BPB shall never underflow.
4. When $SubPicHrdFlag$ is equal to 1, $low_delay_hrd_flag[HighestTid]$ is equal to 1, and the nominal removal time of a decoding unit m of partition unit n is less than the final BPB arrival time of decoding unit m (i.e. $DuNominalRemovalTime[m] < DuFinalArrivalTime[m]$), the nominal removal time of partition unit n shall be less than the final BPB arrival time of partition unit n (i.e. $AuNominalRemovalTime[n] < AuFinalArrivalTime[n]$).
5. The nominal removal times of partition units from the BPB (starting from the second partition unit in decoding order) shall satisfy the constraints on $AuNominalRemovalTime[n]$ and $AuCpbRemovalTime[n]$ expressed in A.4.1 through A.4.2 for bitstreams or layers conforming to profiles defined in Annex A, or expressed in G.11.2.1 through G.11.2.2 for bitstreams or layers conforming to profiles defined in Annex G, or expressed in H.11.2.1 through H.11.2.2 for bitstreams or layers conforming to profiles defined in Annex H.
6. For each current picture, after invocation of the process for removal of pictures from the sub-DPB as specified in F.13.3.2, the number of decoded pictures in the sub-DPB for the current layer, including all pictures n , where each picture n is contained in partition unit k_n , in the current layer that are marked as "used for reference", or that have $PicOutputFlag$ equal to 1 and $AuCpbRemovalTime[k_n]$ less than $AuCpbRemovalTime[currAu]$, where $currAu$ is the partition unit containing the current picture, shall be less than or equal to $max_vps_dec_pic_buffering_minus1[TargetOlsIdx][layerIdx][HighestTid]$, where $layerIdx$ is equal to the value such that $LayerSetLayerIdList[TargetDecLayerSetIdx][layerIdx]$ is equal to $currPicLayerId$.
7. All reference pictures shall be present in the DPB when needed for prediction. Each picture that has $PicOutputFlag$ equal to 1 shall be present in the DPB at its DPB output time unless it is removed from the DPB before its output time by one of the processes specified in F.13.3.
8. For each current picture that is not an IRAP picture with $NoRaslOutputFlag$ equal to 1 or that is not the first picture of the current layer with nuh_layer_id greater than 0 that follows an IRAP picture that has nuh_layer_id equal to 0 and has $NoCllrasOutputFlag$ equal to 1, the value of $maxPicOrderCnt - minPicOrderCnt$ shall be less than $MaxPicOrderCntLsb / 2$.
9. The value of $DpbOutputInterval[n]$ as given by Formula (F-83), which is the difference between the output time of a partition unit that has $AuOutputFlag$ equal to 1 and that of the first partition unit following it in output order and having $AuOutputFlag$ equal to 1, shall satisfy the constraint on $DpbOutputInterval[n]$ expressed in A.4.2 for the profile, tier, and level of the bitstream or layer using the decoding process specified in Clauses 2 through 10, or expressed in G.11.2.2 for the profile, tier, and level of the bitstream or layer using the decoding process specified in F.2 through F.10 and either G.2 through G.10 or H.2 through H.10.
10. For each current picture, when $sub_pic_cpb_params_in_pic_timing_sei_flag$ is equal to 1, let $tmpCpbRemovalDelaySum$ be derived as follows:

```

tmpCpbRemovalDelaySum = 0
for( i = 0; i < num_decoding_units_minus1; i++ )
    tmpCpbRemovalDelaySum += du_cpb_removal_delay_increment_minus1[ i ] + 1

```

(F-87)

The value of $\text{ClockSubTick} * \text{tmpCpbRemovalDelaySum}$ shall be equal to the difference between the nominal BPB removal time of the current partition unit and the nominal BPB removal time of the first decoding unit in the current partition unit in decoding order.

11. Let *picA* be an IRAP picture with *NoRasOutputFlag* equal to 1 and belonging to a layer *layerA*. Let *auB* be the earlier, in decoding order, of the first partition unit containing an IRAP picture with *nuh_layer_id* equal to 0 and *NoClrasOutputFlag* equal to 1 that succeeds *picA* in decoding order and the first partition unit containing an IRAP picture with *NoRasOutputFlag* equal to 1 in *layerA* that succeeds *picA* in decoding order. For any two pictures *picM* and *picN* in the layer *layerA* contained in partition units *m* and *n*, respectively, that either are *picA* or succeed *picA* in decoding order and precede *auB* in decoding order, when $\text{DpbOutputTime}[m]$ is greater than $\text{DpbOutputTime}[n]$, $\text{PicOrderCnt}(\text{picM})$ shall be greater than $\text{PicOrderCnt}(\text{picN})$, where $\text{PicOrderCnt}(\text{picM})$ and $\text{PicOrderCnt}(\text{picN})$ are the PicOrderCntVal values of *picM* and *picN*, respectively, immediately after the invocation of the decoding process for picture order count of the latter of *picM* and *picN* in decoding order.

NOTE 2 All pictures of an earlier CVS in decoding order that are output are output before any pictures of a later CVS in decoding order. Within any particular CVS where all pictures have *poc_reset_id* not present or equal to 0, the pictures that are output are output in increasing PicOrderCntVal order. For any particular CVS where some pictures have *poc_reset_id* greater than 0, within each POC resetting period, the pictures that are output are output in increasing PicOrderCntVal order, and for any two pictures that are output and are in different POC resetting periods, the one that is earlier in decoding order is output earlier.

12. For any decoding unit *m*, $\text{DuCpbRemovalTime}[m]$ shall be greater than or equal to the BPB removal time of the previous DU that precedes the current DU in decoding order and that is in the same bitstream partition as the decoding unit *m* or includes one or more VCL NAL units of a picture that may be used as a direct or indirect reference picture for the picture containing the one or more VCL NAL units included in the decoding unit *m*.
13. The DPB output times derived for all pictures in any particular access unit shall be the same.

F.13.5 Decoder conformance

F.13.5.1 General

A decoder conforming to this document shall fulfil all requirements specified in this subclause.

A decoder claiming conformance to a specific profile, tier and level shall be able to successfully decode all bitstreams that conform to the bitstream conformance requirements specified in F.13.4, in the manner specified in Annexes A, G, and H for profile, tier, and level specified in Annexes A, G, and H, respectively, provided that all VPSs, SPSs and PPSs referred to by the VCL NAL units, appropriate buffering period, picture timing, and decoding unit information SEI messages are conveyed to the decoder, in a timely manner, either in the bitstream (by non-VCL NAL units), or by external means not specified in this document, and, when *vps_base_layer_internal_flag* is equal to 0, the decoded pictures with *nuh_layer_id* equal to 0 and their properties as specified in F.8.1 and its subclauses are conveyed to the decoder in a timely manner by external means not specified in this document.

When a bitstream contains syntax elements that have values that are specified as reserved and it is specified that decoders shall ignore values of the syntax elements or NAL units containing the syntax elements having the reserved values, and the bitstream is otherwise conforming to this document, a conforming decoder shall decode the bitstream in the same manner as it would decode a conforming bitstream and shall ignore the syntax elements or the NAL units containing the syntax elements having the reserved values as specified.

There are two types of conformance that can be claimed by a decoder: output timing conformance and output order conformance.

To check conformance of a decoder, test bitstreams containing one or more bitstream partitions conforming to the claimed profile, tier and level, as specified in F.13.4 are delivered by a hypothetical stream scheduler (HSS) both to the HRD and to the decoder under test (DUT). When `vps_base_layer_internal_flag` is equal to 0, decoded pictures with `nuh_layer_id` equal to 0 and their properties as specified in F.8.1 and its subclauses are also conveyed both to the HRD and to the DUT in a timely manner by external means not specified in this document. All cropped decoded pictures output by the HRD shall also be output by the DUT, each cropped decoded picture output by the DUT shall be a picture with `PicOutputFlag` equal to 1, and, for each such cropped decoded picture output by the DUT, the values of all samples that are output shall be equal to the values of the samples produced by the specified decoding process. The flag `BaseLayerOutputFlag` and all flags `BaseLayerPicOutputFlag` output by the HRD shall also be output by the DUT, and the values that are output shall be equal to the values produced by the specified decoding process.

For output timing decoder conformance, the HSS operates as described above, with delivery schedules selected only from the subset of values of `SchedSelIdx` for which the bit rate and CPB size are restricted as specified in Annexes A, G, and H for the specified profile, tier, and level in Annexes A, G, and H, respectively, or with “interpolated” delivery schedules as specified below for which the bit rate and CPB size are restricted as specified in Annexes A, G, and H for the specified profile, tier, and level in Annexes A, G, and H, respectively. The same delivery schedule is used for both the HRD and the DUT.

When the HRD parameters and the buffering period SEI messages are present with the number of signalled delivery schedules greater than 0, the decoder shall be capable of decoding each bitstream partition as delivered from the HSS operating using an “interpolated” delivery schedule specified as having peak bit rate r , CPB size $c(r)$, and initial CPB removal delay $(f(r) \div r)$ as follows:

$$\alpha = (r - \text{BitRate}[\text{SchedSelIdx} - 1]) \div (\text{BitRate}[\text{SchedSelIdx}] - \text{BitRate}[\text{SchedSelIdx} - 1]), \quad (\text{F-88})$$

$$c(r) = \alpha * \text{CpbSize}[\text{SchedSelIdx}] + (1 - \alpha) * \text{CpbSize}[\text{SchedSelIdx} - 1], \quad (\text{F-89})$$

$$f(r) = \alpha * \text{InitCpbRemovalDelay}[\text{SchedSelIdx}] * \text{BitRate}[\text{SchedSelIdx}] + (1 - \alpha) * \text{InitCpbRemovalDelay}[\text{SchedSelIdx} - 1] * \text{BitRate}[\text{SchedSelIdx} - 1] \quad (\text{F-90})$$

for any $\text{SchedSelIdx} > 0$ and r such that $\text{BitRate}[\text{SchedSelIdx} - 1] \leq r \leq \text{BitRate}[\text{SchedSelIdx}]$ such that r and $c(r)$ are within the limits as specified in Annexes A, G, and H for the maximum bit rate and buffer size for the specified profile, tier and level defined in Annexes A, G, and H, respectively. The following applies for the specifications above:

- Let `combIdx` be any value in the range of 0 to `num_bsp_schedules_minus1[TargetOlsIdx][TargetPsIdx][HighestTid]`, inclusive.
- `SchedSelIdx` shall be one of the values among `bsp_sched_idx[TargetOlsIdx][TargetPsIdx][HighestTid][combIdx][j]` for and j is the index of the bitstream partition index of `TargetBitstreamPartition`.
- `SchedSelIdx - 1` is to be understood as `bsp_sched_idx[TargetOlsIdx][TargetPsIdx][HighestTid][combIdx - 1][j]` for any value of k in the range of 1 to `combIdx`, inclusive.

NOTE 1 `InitCpbRemovalDelay[SchedSelIdx]` can be different from one buffering period to another and need to be recalculated.

For output timing decoder conformance, an HRD as described above is used and the timing (relative to the delivery time of the first bit) of picture output is the same for both the HRD and the DUT up to a fixed delay.

For output order decoder conformance, the following applies for each bitstream partition in TargetPartitioningScheme:

- The HSS delivers the TargetBitstreamPartition to the DUT “by demand” from the DUT, meaning that the HSS delivers bits (in decoding order) only when the DUT requires more bits to proceed with its processing.

NOTE 2 This means that for this test, the coded picture buffer of the DUT could be as small as the size of the largest decoding unit.

- A modified HRD as described below is used, and the HSS delivers the bitstream to the HRD by one of the schedules specified in the TargetBitstreamPartition such that the bit rate and CPB size are restricted as specified in Annex A for profiles defined in Annex A, Annex G for profiles defined in Annex G, and Annex H for profiles defined in Annex H. The order of pictures output shall be the same for both the HRD and the DUT.
- The HRD BPB size is given by $CpbSize[SchedSelIdx]$ as specified in F.13.1. The sub-DPB size of the sub-DPB for a layer with `nuh_layer_id` equal to `currLayerId` is $max_vps_dec_pic_buffering_minus1[TargetOlsIdx][layerIdx][HighestTid] + 1$, where `layerIdx` is equal to the value such that `LayerSetLayerIdList[TargetDeclayerSetIdx][layerIdx]` is equal to `currLayerId`. The removal time from the CPB for the HRD is the final bit arrival time and decoding is immediate. The operation of the DPB of this HRD is as described in F.13.5.2.

F.13.5.2 Operation of the output order DPB

F.13.5.2.1 General

The decoded picture buffer consists of sub-DPBs, and each sub-DPB contains picture storage buffers for storage of decoded pictures of one layer. Each of the picture storage buffers of a sub-DPB contains a decoded picture that is marked as “used for reference” or is held for future output.

The process for output and removal of pictures from the DPB before decoding of the current picture as specified in F.13.5.2.2 is invoked, followed by the invocation of the process for current decoded picture marking and storage as specified in F.13.3.4, further followed by the invocation of the process for removal of pictures from the DPB after decoding of the current picture as specified in F.13.3.5, and finally followed by the invocation of the process for additional bumping as specified in F.13.5.2.3. The “bumping” process is specified in F.13.5.2.4 and is invoked as specified in F.13.5.2.2 and F.13.5.2.3.

These processes are applied independently for each layer, starting from the base layer, in increasing order of the `nuh_layer_id` values of the layers in the bitstream. When these processes are applied for a particular layer, only the sub-DPB for the particular layer is affected except for the “bumping” process, which may crop and output pictures, mark pictures as “not needed for output” and empty picture storage buffers for any layer.

NOTE In the operation of output order DPB, same as in the operation of output timing DPB, decoded pictures with `PicOutputFlag` equal to 1 in the same access unit are also output consecutively in ascending order of the `nuh_layer_id` values of the decoded pictures.

Let picture `n` and the current picture be the coded picture or decoded picture of the access unit `n` for a particular value of `nuh_layer_id`, wherein `n` is a non-negative integer number.

When these processes are applied for a layer with `nuh_layer_id` equal to `currLayerId`, the variables `MaxNumReorderPics`, `MaxLatencyIncreasePlus1`, `MaxLatencyValue`, and `MaxDecPicBufferingMinus1` are derived as follows:

- `MaxNumReorderPics` is set equal to $max_vps_num_reorder_pics[TargetOlsIdx][HighestTid]$ of the active VPS.

ISO/IEC 23008-2:2017(E)

- MaxLatencyIncreasePlus1 is set equal to the value of the syntax element `max_vps_latency_increase_plus1[TargetOlsIdx][HighestTid]` of the active VPS.
- MaxLatencyValue is set equal to `MaxVpsLatencyPictures[TargetOlsIdx][HighestTid]` of the active VPS.
- MaxDecPicBufferingMinus1 is set equal to the value of the syntax element `max_vps_dec_pic_buffering_minus1[TargetOlsIdx][layerIdx][HighestTid]` of the active VPS, where `layerIdx` is equal to the value such that `LayerSetLayerIdList[TargetDeclayerSetIdx][layerIdx]` is equal to `currLayerId`.

F.13.5.2.2 Output and removal of pictures from the DPB before decoding of the current picture

When the current picture is not picture 0 in the current layer, the output and removal of pictures in the current layer, with `nuh_layer_id` equal to `currLayerId`, from the DPB before the decoding of the current picture, i.e. picture `n`, but after parsing the slice header of the first slice of the current picture and before the invocation of the decoding process for picture order count, happens instantaneously when the first decoding unit of the current picture is removed from the CPB and proceeds as follows:

- When the current picture is a POC resetting picture, all pictures in the DPB that do not belong to the current access unit and that are marked as “needed for output” are output, starting with pictures with the smallest value of `PicOrderCntVal` of all pictures excluding those in the current access unit in the DPB, in ascending order of the `PicOrderCntVal` values, and pictures with the same value of `PicOrderCntVal` are output in ascending order of the `nuh_layer_id` values. When a picture is output, it is cropped using the conformance cropping window specified in the active SPS for the picture, the cropped picture is output, and the picture is marked as “not needed for output”.
- The decoding processes for picture order count and RPS are invoked. When decoding a CVS conforming to one or more of the profiles specified in Annex A using the decoding process specified in Clauses 2 through 10, the decoding processes for picture order count and RPS that are invoked are as specified in 8.3.1 and 8.3.2, respectively. When decoding a CVS conforming to one or more of the profiles specified in Annex G or H using the decoding process specified in Annex F, and Annex G or H, the decoding processes for picture order count and RPS that are invoked are as specified in F.8.3.1 and F.8.3.2, respectively.
- The variable `listOfSubDpbsToEmpty` is derived as follows:
 - If a new VPS is activated by the current access unit or the current picture is IRAP picture with `nuh_layer_id` equal to `SmallestLayerId`, `NoRaslOutputFlag` equal to 1, and `NoClrasOutputFlag` equal to 1, `listOfSubDpbsToEmpty` is set equal to all the sub-DPBs.
 - Otherwise, if the current picture is an IRAP picture with any `nuh_layer_id` value `indepLayerId` such that `NumDirectRefLayers[indepLayerId]` is equal to 0 and `indepLayerId` is greater than `SmallestLayerId`, and with `NoRaslOutputFlag` equal to 1, and `LayerResetFlag` is equal to 1, `listOfSubDpbsToEmpty` is set equal to the sub-DPBs containing the current layer and the sub-DPBs containing the predicted layers of the current layer.
 - Otherwise, `listOfSubDpbsToEmpty` is set equal to the sub-DPB containing the current layer.
- If the current picture is an IRAP picture with `NoRaslOutputFlag` equal to 1 and any of the following conditions is true:
 - `nuh_layer_id` equal to `SmallestLayerId`,
 - `nuh_layer_id` of the current layer is greater than `SmallestLayerId`, and `NumDirectRefLayers[nuh_layer_id]` is equal to 0,

the following ordered steps are applied:

1. The variable NoOutputOfPriorPicsFlag is derived for the decoder under test as follows:
 - If the current picture is a CRA picture, NoOutputOfPriorPicsFlag is set equal to 1 (regardless of the value of no_output_of_prior_pics_flag).
 - Otherwise, if the value of pic_width_in_luma_samples, pic_height_in_luma_samples, chroma_format_idc, bit_depth_luma_minus8, bit_depth_chroma_minus8, separate_colour_plane_flag, or sps_max_dec_pic_buffering_minus1[HighestTid] derived from the active SPS for the current layer is different from the value of pic_width_in_luma_samples, pic_height_in_luma_samples, chroma_format_idc, bit_depth_luma_minus8, bit_depth_chroma_minus8, separate_colour_plane_flag, or sps_max_dec_pic_buffering_minus1[HighestTid], respectively, derived from the SPS that was active for the current layer when decoding the preceding picture in the current layer, NoOutputOfPriorPicsFlag may (but should not) be set equal to 1 by the decoder under test, regardless of the value of no_output_of_prior_pics_flag.

NOTE Although setting NoOutputOfPriorPicsFlag equal to no_output_of_prior_pics_flag is preferred under these conditions, the decoder under test is allowed to set NoOutputOfPriorPicsFlag to 1 in this case.
 - Otherwise, NoOutputOfPriorPicsFlag is set equal to no_output_of_prior_pics_flag.
2. The value of NoOutputOfPriorPicsFlag derived for the decoder under test is applied for the HRD as follows:
 - If NoOutputOfPriorPicsFlag is equal to 0, all non-empty picture storage buffers in all the sub-DPBs included in listOfSubDpbsToEmpty are output by repeatedly invoking the “bumping” process specified in F.13.5.2.4 until all these pictures are marked as “not needed for output”.
 - Otherwise (NoOutputOfPriorPicsFlag is equal to 1), all picture storage buffers containing a picture that is marked as “not needed for output” and “unused for reference” are emptied (without output), all pictures that are contained in a sub-DPB included in listOfSubDpbsToEmpty are emptied, and the sub-DPB fullness of each sub-DPB is decremented by the number of picture storage buffers emptied in that sub-DPB.
 - Otherwise, all picture storage buffers that contain a picture in the current layer and that are marked as “not needed for output” and “unused for reference” are emptied (without output). For each picture storage buffer that is emptied, the sub-DPB fullness is decremented by one. When one or more of the following conditions are true, the “bumping” process specified in F.13.5.2.4 is invoked repeatedly until none of the following conditions are true:
 - The number of access units that contain at least one decoded picture in the DPB marked as “needed for output” is greater than MaxNumReorderPics.
 - MaxLatencyIncreasePlus1 is not equal to 0 and there is at least one access unit that contains at least one decoded picture in the DPB marked as “needed for output” for which the associated variable PicLatencyCount is greater than or equal to MaxLatencyValue.
 - The number of pictures in the sub-DPB is greater than or equal to MaxDecPicBufferingMinus1 + 1 – TwoVersionsOfCurrDecPicFlag.

ISO/IEC 23008-2:2017(E)

F.13.5.2.3 Additional bumping

The processes specified in this subclause happen instantaneously when the last decoding unit of picture n is removed from the CPB.

When the current picture is the last picture in an access unit, the following applies for each decoded picture with nuh_layer_id greater than or equal to $(\text{vps_base_layer_internal_flag} ? 0 : 1)$ of the access unit:

- If the decoded picture has PicOutputFlag equal to 1, it is marked as “needed for output”.
- Otherwise (the decoded picture has PicOutputFlag equal to 0), it is marked as “not needed for output”.

NOTE Prior to investigating the conditions above, PicOutputFlag of each picture of the access unit is updated as specified in F.8.1.2.

When one or more of the following conditions are true, the “bumping” process specified in F.13.5.2.4 is invoked repeatedly until none of the following conditions are true:

- The number of access units that contain at least one decoded picture in the DPB marked as “needed for output” is greater than MaxNumReorderPics .
- $\text{MaxLatencyIncreasePlus1}$ is not equal to 0 and there is at least one access unit that contains at least one decoded picture in the DPB marked as “needed for output” for which the associated variable PicLatencyCount is greater than or equal to MaxLatencyValue .

F.13.5.2.4 “Bumping” process

The “bumping” process consists of the following ordered steps:

1. The picture or pictures that are first for output are selected as the ones having the smallest value of PicOrderCntVal of all pictures in the DPB marked as “needed for output”.
2. Each of these pictures is, in ascending nuh_layer_id order, cropped, using the conformance cropping window specified in the active SPS for the picture, the cropped picture is output, and the picture is marked as “not needed for output”.
3. Each picture storage buffer that contains a picture marked as “unused for reference” and that was one of the pictures cropped and output is emptied and the fullness of the associated sub-DPB is decremented by one.

F.13.6 Demultiplexing process for deriving a bitstream partition

Inputs to this process are a bitstream, a layer identifier list $\text{bspLayerId}[\text{bspIdx}]$, and the number of layer identifiers numBspLayers in the layer index list $\text{bspLayerId}[\text{bspIdx}]$.

Output of this process is a bitstream partition.

Let the variable minBspLayerId be the smallest value of $\text{bspLayerId}[\text{bspIdx}]$ with any value of bspIdx in the range of 0 to $\text{numBspLayers} - 1$, inclusive.

The output bitstream partition consists of selected NAL units of the input bitstream in the same order as they appear in the input bitstream. The following NAL units of the input bitstream are omitted from the output bitstream partition, while the remaining NAL units of the input bitstream are included in the output bitstream partition:

- Omit all NAL units that have a nuh_layer_id value other than $\text{bspLayerId}[\text{bspIdx}]$ with any value of bspIdx in the range of 0 to $\text{numBspLayers} - 1$, inclusive.

- Omit all SEI NAL units containing a scalable nesting SEI message for which no derived nestingLayerIdList[i] contains any layer identifier value equal to bspLayerId[bspIdx] with any value of bspIdx in the range of 0 to numBspLayers – 1, inclusive.
- Omit all SEI NAL units containing a scalable nesting SEI message for which a derived nestingLayerIdList[i] contains a layer identifier value less than minBspLayerId.

F.14 Supplemental enhancement information

F.14.1 General

The specifications in D.1 apply.

F.14.2 SEI payload syntax

F.14.2.1 General SEI payload syntax

The specifications in D.2.1 apply.

F.14.2.2 Annex D SEI message syntax for multi-layer extensions

The specifications in D.2.2 through D.2.40 apply.

F.14.2.3 Layers not present SEI message syntax

	Descriptor
layers_not_present(payloadSize) {	
lnp_sei_active_vps_id	u(4)
for(i = 0; i <= MaxLayersMinus1; i++)	
layer_not_present_flag[i]	u(1)
}	

F.14.2.4 Inter-layer constrained tile sets SEI message syntax

	Descriptor
inter_layer_constrained_tile_sets(payloadSize) {	
il_all_tiles_exact_sample_value_match_flag	u(1)
il_one_tile_per_tile_set_flag	u(1)
if(!il_one_tile_per_tile_set_flag) {	
il_num_sets_in_message_minus1	ue(v)
if(il_num_sets_in_message_minus1)	
skipped_tile_set_present_flag	u(1)
numSignificantSets = il_num_sets_in_message_minus1 – skipped_tile_set_present_flag + 1	
for(i = 0; i < numSignificantSets; i++) {	
ilcts_id[i]	ue(v)
il_num_tile_rects_in_set_minus1[i]	ue(v)
for(j = 0; j <= il_num_tile_rects_in_set_minus1[i]; j++) {	
il_top_left_tile_index[i][j]	ue(v)
il_bottom_right_tile_index[i][j]	ue(v)
}	
}	

ilc_idc[i]	u(2)
if (!il_all_tiles_exact_sample_value_match_flag)	
il_exact_sample_value_match_flag[i]	u(1)
}	
} else	
all_tiles_ilc_idc	u(2)
}	

F.14.2.5 Bitstream partition nesting SEI message syntax

bsp_nesting(payloadSize) {	Descriptor
sei_ols_idx	ue(v)
sei_partitioning_scheme_idx	ue(v)
bsp_idx	ue(v)
num_seis_in_bsp_minus1	ue(v)
while(!byte_aligned())	
bsp_nesting_zero_bit /* equal to 0 */	u(1)
for(i = 0; i <= num_seis_in_bsp_minus1; i++)	
sei_message()	
}	

F.14.2.6 Bitstream partition initial arrival time SEI message syntax

bsp_initial_arrival_time(payloadSize) {	Descriptor
psIdx = sei_partitioning_scheme_idx	
if(nalInitialArrivalDelayPresent)	
for(i = 0; i < BspSchedCnt[sei_ols_idx][psIdx][MaxTemporalId[0]]; i++)	
nal_initial_arrival_delay[i]	u(v)
if(vclInitialArrivalDelayPresent)	
for(i = 0; i < BspSchedCnt[sei_ols_idx][psIdx][MaxTemporalId[0]]; i++)	
vcl_initial_arrival_delay[i]	u(v)
}	

F.14.2.7 Sub-bitstream property SEI message syntax

	Descriptor
sub_bitstream_property(payloadSize) {	
sb_property_active_vps_id	u(4)
num_additional_sub_streams_minus1	ue(v)
for(i = 0; i <= num_additional_sub_streams_minus1; i++) {	
sub_bitstream_mode[i]	u(2)
ols_idx_to_vps[i]	ue(v)
highest_sublayer_id[i]	u(3)
avg_sb_property_bit_rate[i]	u(16)
max_sb_property_bit_rate[i]	u(16)
}	
}	

F.14.2.8 Alpha channel information SEI message syntax

	Descriptor
alpha_channel_info(payloadSize) {	
alpha_channel_cancel_flag	u(1)
if(!alpha_channel_cancel_flag) {	
alpha_channel_use_idc	u(3)
alpha_channel_bit_depth_minus8	u(3)
alpha_transparent_value	u(v)
alpha_opaque_value	u(v)
alpha_channel_incr_flag	u(1)
alpha_channel_clip_flag	u(1)
if(alpha_channel_clip_flag)	
alpha_channel_clip_type_flag	u(1)
}	
}	

F.14.2.9 Overlay information SEI message syntax

	Descriptor
overlay_info(payloadSize) {	
overlay_info_cancel_flag	u(1)
if(!overlay_info_cancel_flag) {	
overlay_content_aux_id_minus128	ue(v)
overlay_label_aux_id_minus128	ue(v)
overlay_alpha_aux_id_minus128	ue(v)
overlay_element_label_value_length_minus8	ue(v)
num_overlays_minus1	ue(v)
for(i = 0; i <= num_overlays_minus1; i++) {	
overlay_idx[i]	ue(v)
language_overlay_present_flag[i]	u(1)
}	
}	

overlay_content_layer_id [i]	u(6)
overlay_label_present_flag [i]	u(1)
if(overlay_label_present_flag[i])	
overlay_label_layer_id [i]	u(6)
overlay_alpha_present_flag [i]	u(1)
if(overlay_alpha_present_flag[i])	
overlay_alpha_layer_id [i]	u(6)
if(overlay_label_present_flag[i]) {	
num_overlay_elements_minus1 [i]	ue(v)
for(j = 0; j <= num_overlay_elements_minus1[i]; j++) {	
overlay_element_label_min [i][j]	u(v)
overlay_element_label_max [i][j]	u(v)
}	
}	
}	
while(!byte_aligned())	
overlay_zero_bit /* equal to 0 */	f(1)
for(i = 0; i <= num_overlays_minus1; i++) {	
if(language_overlay_present_flag[i])	
overlay_language [i]	st(v)
overlay_name [i]	st(v)
if(overlay_label_present_flag[i])	
for(j = 0; j <= num_overlay_elements_minus1[i]; j++)	
overlay_element_name [i][j]	st(v)
}	
overlay_info_persistence_flag	u(1)
}	
}	

F.14.2.10 Temporal motion vector prediction constraints SEI message syntax

temporal_mv_prediction_constraints(payloadSize) {	Descriptor
prev_pics_not_used_flag	u(1)
no_intra_layer_col_pic_flag	u(1)
}	

F.14.2.11 Frame-field information SEI message syntax

	Descriptor
frame_field_info(payloadSize) {	
ffinfo_pic_struct	u(4)
ffinfo_source_scan_type	u(2)
ffinfo_duplicate_flag	u(1)
}	

F.14.3 SEI payload semantics

F.14.3.1 General SEI payload semantics

The general SEI payload semantics specified in D.3.1 apply with the following modifications and additions.

The list VclAssociatedSeiList is set to consist of the payloadType values 2, 3, 6, 9, 15, 16, 17, 19, 22, 23, 45, 47, 56, 128, 131, 132, 134 to 148, inclusive, 161, 165, 167, and 168.

The list PicUnitRepConSeiList is set to consist of the payloadType values 0, 1, 2, 6, 9, 15, 16, 17, 19, 22, 23, 45, 47, 56, 128, 129, 131, 132, 133, 135 to 148, inclusive, and 160 to 168, inclusive.

The semantics and persistence scope for each SEI message specified in this annex are specified in the semantics specification for each particular SEI message in F.14.3.3 to F.14.3.11, inclusive.

NOTE Persistence information for SEI messages specified in this annex is informatively summarized in Table F.4.

Table F.4 — Persistence scope of SEI messages (informative)

SEI message	Persistence scope
Layers not present	Specified by the semantics of the SEI message
Inter-layer constrained tile sets	The CLVS associated with the SEI message
Bitstream partition nesting	Depending on the nested SEI messages. Each nested SEI message has the same persistence scope as if the SEI message was not nested
Bitstream partition initial arrival time	The remainder of the bitstream partition (specified by the containing bitstream partition nesting SEI message)
Sub-bitstream property	The CVS containing the SEI message
Alpha channel information	Specified by the syntax of the SEI message
Overlay information	Specified by the syntax of the SEI message
Temporal motion vector prediction constraints	Specified by the semantics of the SEI message
Frame-field information	The access unit containing the SEI message

Let prevVclNalUnitInAu of an SEI NAL unit or an SEI message be the preceding VCL NAL unit in decoding order, if any, in the same access unit, and nextVclNalUnitInAu of an SEI NAL unit or an SEI message be the next VCL NAL unit in decoding order, if any, in the same access unit. It is a requirement of bitstream conformance that the following restrictions apply:

- When a buffering period SEI message, a picture timing SEI message, a decoding unit information SEI message, or a bitstream partition initial arrival time SEI message is present in a bitstream partition nesting SEI message contained in a scalable nesting SEI message, the scalable nesting SEI

message shall not follow any other SEI message that follows the `prevVclNalUnitInAu` of the scalable nesting SEI message and precedes the `nextVclNalUnitInAu` of the scalable nesting SEI message, other than an active parameter sets SEI message, a non-nested buffering period SEI message, a non-nested picture timing SEI message, a non-nested decoding unit information SEI message, a scalable nesting SEI message including a buffering period SEI message, a picture timing SEI message, a decoding unit information SEI message, or another scalable nesting SEI message that contains a bitstream partition nesting SEI message including a buffering period SEI message, a picture timing SEI message, a decoding unit information SEI message, or a bitstream partition initial arrival time SEI message.

F.14.3.2 Annex D SEI message semantics for multi-layer extensions

F.14.3.2.1 General

The semantics of SEI messages specified in D.3.2 through D.3.40 apply with the modifications specified in F.14.3.2.2 through F.14.3.2.8.

F.14.3.2.2 Buffering period SEI message semantics for multi-layer extensions

The specifications of D.3.2 apply with the following modifications and additions.

When the buffering period SEI message is directly contained in a scalable nesting SEI message within an SEI NAL unit with a `nuh_layer_id` value `targetNuhLayerId` greater than 0, the semantics of D.3.2 apply to the output bitstream of the independent non-base layer rewriting process of F.10.2 with the input variables `assignedBaseLayerId` equal to `nestingLayerIdList[i][0]` and `tIdTarget` equal to `MaxTemporalId[i]` for each value of `i` in the range of 0 to `nestingNumOps - 1`, inclusive.

When the buffering period SEI message is contained in a bitstream partition nesting SEI message, the following apply:

- A set of skipped leading pictures `skippedPictureList` consists of the CL-RAS pictures and the RASL pictures associated with the IRAP pictures with `nuh_layer_id` equal to `nuhLayerId` for which `LayerInitializedFlag[nuhLayerId]` is equal to 0 at the start of decoding the IRAP picture and for which `nuhLayerId` is among the `nestingLayerIdList[i]` for any value of `i` in the range of 0 to `nesting_num_ops_minus1`, inclusive.
- A picture is said to be a `notDiscardablePic` picture when the picture has `TemporalId` equal to 0, has `discardable_flag` equal to 0, and is not a RASL, RADL, or SLNR picture.
- The variables `olsIdx`, `psIdx`, and `bspIdx` are set equal to `sei_ols_idx`, `sei_partitioning_scheme_idx`, and `bsp_idx`, respectively, of the bitstream partition nesting SEI message containing this buffering period SEI message, and the `bspIdx`-th bitstream partition of the `psIdx`-th partitioning scheme of the `olsIdx`-th OLS is referred to as the current bitstream partition.
- The variable `maxTId` is set equal to `MaxTemporalId[0]` for the scalable nesting SEI message containing the bitstream partition nesting SEI message containing this buffering period SEI message.
- The variable `CpbCnt` is set equal to `BspSchedCnt[olsIdx][psIdx][maxTId] - 1` for the syntax and semantics of the buffering period SEI message and for the constraints specified below.
- The variable `hrdParamIdx[i]` is set equal to the value of `bsp_hrd_idx[olsIdx][psIdx][maxTId][i][bspIdx]` for each value of `i` in the range of 0 to `CpbCnt`, inclusive.
- The syntax elements `au_cpb_removal_delay_length_minus1`, `dpb_output_delay_length_minus1`, and `sub_pic_hrd_params_present_flag` are found in or derived from the `hrdParamIdx[i]`-th `hrd_parameters()` syntax structure for any value of `i` in the range of 0 to `CpbCnt`. It is a requirement

of bitstream conformance that the values of `au_cpb_removal_delay_length_minus1`, `dpb_output_delay_length_minus1`, and `sub_pic_hrd_params_present_flag` derived using a particular value of `i` shall be the same as the value of the respective syntax elements derived using any other allowed value of `i`.

- The syntax element `initial_cpb_removal_delay_length_minus1` is found in or derived from the `hrdParamIdx[i]`-th `hrd_parameters()` syntax structure for the semantics of `nal_initial_cpb_removal_delay[i]`, `nal_initial_alt_cpb_removal_delay[i]`, `nal_initial_cpb_removal_offset[i]`, `nal_initial_alt_cpb_removal_offset[i]`, `vcl_initial_cpb_removal_delay[i]`, `vcl_initial_alt_cpb_removal_delay[i]`, `vcl_initial_cpb_removal_offset[i]`, and `vcl_initial_alt_cpb_removal_offset[i]`.
- The variable `CpbSize[i]` is set equal to `BpbSize[olsIdx][psIdx][maxTId][i][bspIdx]` for the semantics of `nal_initial_cpb_removal_delay[i]`, `nal_initial_alt_cpb_removal_delay[i]`, `vcl_initial_cpb_removal_delay[i]`, and `vcl_initial_alt_cpb_removal_delay[i]`.
- The variable `BitRate[i]` is set equal to `BpBitRate[olsIdx][psIdx][maxTId][i][bspIdx]` for the semantics of `nal_initial_cpb_removal_delay[i]`, `nal_initial_alt_cpb_removal_delay[i]`, `vcl_initial_cpb_removal_delay[i]`, and `vcl_initial_alt_cpb_removal_delay[i]`.
- The variables `NalHrdBpPresentFlag` and `VclHrdBpPresentFlag` are derived from the `hrdParamIdx[i]`-th `hrd_parameters()` syntax structure for any value of `i` in the range of 0 to `CpbCnt`. It is a requirement of bitstream conformance that the value of `NalHrdBpPresentFlag` shall be the same regardless of the value of `i` used in its derivation. It is a requirement of bitstream conformance that the value of `VclHrdBpPresentFlag` shall be the same regardless of the value of `i` used in its derivation.

The presence of buffering period SEI messages for the current bitstream partition is specified as follows on the basis of the variables `NalHrdBpPresentFlag` and `VclHrdBpPresentFlag` that are derived as specified above:

- If `NalHrdBpPresentFlag` is equal to 1 or `VclHrdBpPresentFlag` is equal to 1, the following applies for each access unit in the CVS:
 - If the access unit is an IRAP access unit, a buffering period SEI message applicable to the current bitstream partition shall be associated with the access unit.
 - Otherwise, if the access unit contains a `notDiscardablePic` in at least one layer included in the current bitstream partition, a buffering period SEI message applicable to the current bitstream partition may or may not be associated with the access unit.
 - Otherwise, the access unit shall not be associated with a buffering period SEI message applicable to the current bitstream partition.
- Otherwise (`NalHrdBpPresentFlag` and `VclHrdBpPresentFlag` are both equal to 0), no access unit in the CVS shall be associated with a buffering period SEI message applicable to the current bitstream partition.

When the buffering period SEI message is contained in a bitstream partition nesting SEI message, the following semantics of `concatenation_flag` and `au_cpb_removal_delay_delta_minus1` replace those specified in D.3.2 and the following specifications apply to each picture `currPic` with `nuh_layed_id currNuhLayerId` equal to any value included in the current bitstream partition in the current access unit.

When the picture `currPic` with `nuh_layer_id` equal to `targetLayerId` in the current access unit is not the first picture with that `nuh_layer_id` value in the bitstream in decoding order, let `prevNonDiscardablePic`

be the preceding picture in decoding order with that `nuh_layer_id` value and with `TemporalId` equal to 0 that is not a RASL, RADL, or SLNR picture.

concatenation_flag indicates, when the picture `currPic` is not the first picture with `nuh_layer_id` equal to `currNuhLayerId` in the bitstream in decoding order, whether the nominal CPB removal time of the current picture is determined relative to the nominal CPB removal time of the preceding picture with a buffering period SEI message that applies to the current bitstream partition, or relative to the nominal CPB removal time of the picture `prevNonDiscardablePic`.

au_cpb_removal_delay_delta_minus1 plus 1, when the picture `currPic` is not the first picture with `nuh_layer_id` equal to `currNuhLayerId` in the bitstream in decoding order, specifies a CPB removal delay increment value relative to the nominal CPB removal time of the picture `prevNonDiscardablePic`. This syntax element has a length in bits given by `au_cpb_removal_delay_length_minus1 + 1`.

When the buffering period SEI message is contained in a bitstream partition nesting SEI message and `concatenation_flag` is equal to 0 and the picture `currPic` is not the first picture with `nuh_layer_id` equal to `currNuhLayerId` in the bitstream in decoding order, it is a requirement of bitstream conformance that the following constraint apply:

- If the picture `prevNonDiscardablePic` is not associated with a buffering period SEI message that applies the current bitstream partition, the `au_cpb_removal_delay_minus1` of the picture `currPic` shall be equal to the `au_cpb_removal_delay_minus1` of `prevNonDiscardablePic`, indicated in the picture timing SEI message applicable to the current bitstream partition, plus `au_cpb_removal_delay_delta_minus1 + 1`.
- Otherwise, `au_cpb_removal_delay_minus1`, indicated for the picture `currPic` in the picture timing SEI message applicable to the current bitstream partition, shall be equal to `au_cpb_removal_delay_delta_minus1`.

F.14.3.2.3 Picture timing SEI message semantics for multi-layer extensions

The specifications of D.3.3 apply with the following modifications and additions.

When the picture timing SEI message is directly contained in a scalable nesting SEI message within an SEI NAL unit with a `nuh_layer_id` value `targetNuhLayerId` greater than 0, the semantics of D.3.3 apply to the output bitstream of the independent non-base layer rewriting process of F.10.2 with the input variables `assignedBaseLayerId` equal to `nestingLayerIdList[i][0]` and `tIdTarget` equal to `MaxTemporalId[i]` for each value of `i` in the range of 0 to `nestingNumOps - 1`, inclusive.

When the picture timing SEI message is contained in a bitstream partition nesting SEI message, the following apply:

- `frame_field_info_present_flag` is inferred to be equal to 0 for the syntax and semantics of the picture timing SEI message.

NOTE 1 The frame-field information SEI message can be used to indicate the frame-field information.

- The variables `olsIdx`, `psIdx`, and `bspIdx` are set equal to `sei_ols_idx`, `sei_partitioning_scheme_idx`, and `bsp_idx`, respectively, of the bitstream partition nesting SEI message containing this buffering period SEI message, and the `bspIdx`-th bitstream partition of the `psIdx`-th partitioning scheme of the `olsIdx`-th OLS is referred to as the current bitstream partition.
- The variable `maxTId` is set equal to `MaxTemporalId[0]` for the scalable nesting SEI message containing the bitstream partition nesting SEI message containing this buffering period SEI message.
- The variable `hrdParamIdx` is set equal to the value of `bsp_hrd_idx[olsIdx][psIdx][maxTId][i][bspIdx]` for any value of `i` in the range of 0 to `BspSchedCnt[olsIdx][psIdx][maxTId] - 1`, inclusive.

- The following applies for the syntax and semantics of the picture timing SEI message:
 - The syntax elements `sub_pic_hrd_params_present_flag`, `sub_pic_cpb_params_in_pic_timing_sei_flag`, `au_cpb_removal_delay_length_minus1`, `dpb_output_delay_length_minus1`, `dpb_output_delay_du_length_minus1`, `du_cpb_removal_delay_increment_length_minus1`, and the variable `CpbDpbDelaysPresentFlag` are found in or derived from syntax elements found in the `hrdParamIdx`-th `hrd_parameters()` syntax structure.
 - It is a requirement of bitstream conformance that the values of `sub_pic_hrd_params_present_flag`, `sub_pic_cpb_params_in_pic_timing_sei_flag`, `au_cpb_removal_delay_length_minus1`, `dpb_output_delay_length_minus1`, `dpb_output_delay_du_length_minus1`, `du_cpb_removal_delay_increment_length_minus1`, and `CpbDpbDelaysPresentFlag` derived using a particular value of `i` for the derivation of `hrdParamIdx` shall be the same as the value of the respective syntax elements or variable derived using any other allowed value of `i`.

The presence of picture timing SEI messages for the current bitstream partition is specified as follows on the basis of the variable `CpbDpbDelaysPresentFlag` that is derived as specified above:

- If `CpbDpbDelaysPresentFlag` is equal to 1, a picture timing SEI message applicable to the current bitstream partition shall be associated with every access unit in the CVS.
- Otherwise, in the CVS there shall be no access unit that is associated with a picture timing SEI message applicable to the current bitstream partition.

The semantics of `num_decoding_units_minus1` and `num_nalus_in_du_minus1[i]` are replaced with the following:

The variables `targetUnit` and `totalSizeInCtbsY` are derived as follows:

- If the picture timing SEI message is associated with a partition unit, `targetUnit` is set to be the partition unit, and the value of `totalSizeInCtbsY` is set equal to the sum of the `PicSizeInCtbsY` of all pictures in the partition unit.
- Otherwise (the picture timing SEI message is associated with an access unit), `targetUnit` is set to be the access unit, and the value of `totalSizeInCtbsY` is set equal to the sum of the `PicSizeInCtbsY` of all pictures in the access unit.

`num_decoding_units_minus1` plus 1 specifies the number of decoding units in `targetUnit`. The value of `num_decoding_units_minus1` shall be in the range of 0 to `totalSizeInCtbsY - 1`, inclusive.

`num_nalus_in_du_minus1[i]` plus 1 specifies the number of NAL units in the `i`-th decoding unit of `targetUnit`. The value of `num_nalus_in_du_minus1[i]` shall be in the range of 0 to `totalSizeInCtbsY - 1`, inclusive.

The first decoding unit of `targetUnit` consists of the first `num_nalus_in_du_minus1[0] + 1` consecutive NAL units in decoding order in `targetUnit`. The `i`-th (with `i` greater than 0) decoding unit of `targetUnit` consists of the `num_nalus_in_du_minus1[i] + 1` consecutive NAL units immediately following the last NAL unit in the previous decoding unit of `targetUnit`, in decoding order. There shall be at least one VCL NAL unit in each decoding unit. All non-VCL NAL units associated with a VCL NAL unit shall be included in the same decoding unit as the VCL NAL unit.

F.14.3.2.4 Recovery point SEI message semantics for multi-layer extensions

The recovery point SEI message assists a decoder in determining when the decoding process will produce acceptable pictures in the current layer for display after the decoder initiates random access, layer up-switching, or after the encoder indicates a broken link.

When all decoded pictures in earlier access units in decoding order are removed from the bitstream, the recovery point picture and all the subsequent pictures in output order in the current layer can be correctly or approximately correctly decoded, the current picture is referred to as a layer random-accessing picture. When all the pictures that belong to the reference layers of the current layer and may be used for reference by the current picture or subsequent pictures in decoding order are correctly decoded, and the recovery point picture and all the subsequent pictures in output order in the current layer can be correctly or approximately correctly decoded when no picture prior to the current picture in decoding order in the current layer are present in the bitstream, the current picture is referred to as a layer up-switching picture.

When the recovery point SEI message applies to the current layer and all the reference layers of the current layer, the current picture is indicated as a layer random-accessing picture. When the recovery point SEI message applies to the current layer but not to all the reference layers of the current layer, the current picture is indicated as a layer up-switching picture.

Decoded pictures in the current layer produced by random access or layer up-switching at or before the current access unit does not need to be correct in content until the indicated recovery point, and the operation of the decoding process for pictures in the current layer starting at the current picture may contain references to pictures unavailable in the decoded picture buffer.

In addition, by use of the `broken_link_flag`, the recovery point SEI message can indicate to the decoder the location of some pictures in the current layer in the bitstream that can result in serious visual artefacts when displayed, even when the decoding process was begun at the location of a previous IRAP access unit in decoding order that contain IRAP pictures in all layers.

NOTE 1 The `broken_link_flag` can be used by encoders to indicate the location of a point after which the decoding process for the decoding of some pictures in the current layer may cause references to pictures that, though available for use in the decoding process, are not the pictures that were used for reference when the bitstream was originally encoded (e.g. due to a splicing operation performed during the generation of the bitstream).

When the current picture is a layer random access-accessing picture and random access is performed to start decoding from the current access unit, the decoder operates as if the current access unit was the first access unit in the bitstream in decoding order, and the following apply:

- If `poc_msb_cycle_val` is present for the current picture, the `PicOrderCntVal` of the current picture is derived as specified in the process for derivation of `PicOrderCntVal` in F.8.3.1.
- Otherwise (`poc_msb_cycle_val` is not present for the current picture), the variable `PrevPicOrderCnt[nuh_layer_id]` used in derivation of `PicOrderCntVal` for each picture in the access unit is set equal to 0.

NOTE 2 When HRD information is present in the bitstream, a buffering period SEI message is expected to be associated with the access unit associated with the recovery point SEI message in order to establish initialization of the HRD buffer model after a random access.

When the current picture is either a layer random-accessing picture or a layer up-switching picture and layer up-switching is performed to start decoding of the current layer from the current access (while decoding of the reference layers of the current layer have started earlier and pictures of those layers in the current access unit are correctly decoded), the decoder operates as if the current picture was the first picture of the current layer in the bitstream in decoding order, and the `PicOrderCntVal` of the current picture is set equal to the `PicOrderCntVal` of any other decoded picture in the current access unit.

For a particular access unit auA, let auB be the first access unit that succeeds auA in decoding order such that the picture order count values of the pictures in auB can be derived without using the picture order count values of pictures preceding auB in decoding order. For a particular layer layerA, auA is not allowed to contain a recovery point SEI message that applies to a set of layers containing at least layerA and all reference layers of layerA when all of the following conditions are true:

- All pictures in auA that are in the reference layers, if any, of layerA have both poc_msb_cycle_val_present_flag and poc_reset_idc equal to 0.
- There is at least one picture picA with poc_msb_cycle_val_present_flag equal to 1 in the following access units:
 - Access units that follow auA in decoding order and precede auB, when present, in decoding order.
 - Access unit auB, when present and when picture in auB with nuh_layer_id equal to 0 is not an IRAP picture with NoClrasOutputFlag equal to 1.

Any SPS or PPS RBSP that is referred to by a picture of the access unit containing a recovery point SEI message or by any picture in a subsequent access unit in decoding order shall be available to the decoding process prior to its activation, regardless of whether or not the decoding process is started at the beginning of the bitstream or with the access unit, in decoding order, that contains the recovery point SEI message.

recovery_poc_cnt specifies the recovery point of decoded pictures in the current layer in output order. If there is a picture picB in the current layer that follows the current picture picA but precedes an access unit containing an IRAP picture in the current layer in decoding order and $\text{PicOrderCnt}(\text{picB})$ is equal to $\text{PicOrderCnt}(\text{picA})$ plus the value of recovery_poc_cnt, where $\text{PicOrderCnt}(\text{picA})$ and $\text{PicOrderCnt}(\text{picB})$ are the PicOrderCntVal values of picA and picB, respectively, immediately after the invocation of the decoding process for picture order count for picB, the picture picB is referred to as the recovery point picture. Otherwise, the first picture picC in the current layer in output order for which $\text{PicOrderCnt}(\text{picC})$ is greater than $\text{PicOrderCnt}(\text{picA})$ plus the value of recovery_poc_cnt is referred to as the recovery point picture, where $\text{PicOrderCnt}(\text{picA})$ and $\text{PicOrderCnt}(\text{picC})$ are the PicOrderCntVal values of picA and picC, respectively, immediately after the invocation of the decoding process for picture order count for picC. The recovery point picture shall not precede the current picture in decoding order. All decoded pictures in the current layer in output order are indicated to be correct or approximately correct in content starting at the output order position of the recovery point picture. The value of recovery_poc_cnt shall be in the range of $-\text{MaxPicOrderCntLsb} / 2$ to $\text{MaxPicOrderCntLsb} / 2 - 1$, inclusive.

exact_match_flag indicates whether decoded pictures in the current layer at and subsequent to the specified recovery point in output order derived by starting the decoding process at the access unit containing the recovery point SEI message will be an exact match to the pictures in the current layer that would be produced by starting the decoding process at the location of a previous access unit where the picture of the layer in the current layer and the pictures of all the reference layers are IRAP pictures, if any, in the bitstream. The value 0 indicates that the match may not be exact and the value 1 indicates that the match will be exact. When exact_match_flag is equal to 1, it is a requirement of bitstream conformance that the decoded pictures in the current layer at and subsequent to the specified recovery point in output order derived by starting the decoding process at the access unit containing the recovery point SEI message shall be an exact match to the pictures in the current layer that would be produced by starting the decoding process at the location of a previous access unit where the picture in the current layer and the pictures of all the reference layers are IRAP pictures, if any, in the bitstream.

NOTE 3 When performing random access, decoders are expected to infer all references to unavailable pictures as references to pictures containing only intra coding blocks and having sample values given by Y equal to $(1 \ll (\text{BitDepth}_Y - 1))$, Cb and Cr both equal to $(1 \ll (\text{BitDepth}_C - 1))$ (mid-level grey), regardless of the value of exact_match_flag.

When `exact_match_flag` is equal to 0, the quality of the approximation at the recovery point is chosen by the encoding process and is not specified in this document.

broken_link_flag indicates the presence or absence of a broken link in the current layer at the location of the recovery point SEI message and is assigned further semantics as follows:

- If `broken_link_flag` is equal to 1, pictures in the current layer produced by starting the decoding process at the location of a previous access unit where the picture in the current layer and the pictures of all the reference layers are IRAP pictures may contain undesirable visual artefacts to the extent that decoded pictures in the current layer at and subsequent to the access unit containing the recovery point SEI message in decoding order should not be displayed until the specified recovery point in output order.
- Otherwise (`broken_link_flag` is equal to 0), no indication is given regarding any potential presence of visual artefacts.

When the current picture is a BLA picture, the value of `broken_link_flag` shall be equal to 1.

Regardless of the value of the `broken_link_flag`, pictures in the current layer subsequent to the specified recovery point in output order are specified to be correct or approximately correct in content.

F.14.3.2.5 Structure of pictures information SEI message semantics for multi-layer extensions

The specifications of D.3.19 apply by replacing the first paragraph specifying the persistence of the SEI message with the following.

The structure of pictures information SEI message provides information for a list of entries, some of which correspond to the target picture set consists of a series of pictures starting from the current picture until the last picture in decoding order in the current layer in the CLVS or the last picture in decoding order in the current POC resetting period, whichever is earlier.

F.14.3.2.6 Decoding unit information SEI message semantics for multi-layer extensions

The specifications of D.3.22 apply with the following modifications and additions.

When the decoding unit information SEI message is directly contained in a scalable nesting SEI message within an SEI NAL unit with a `nuh_layer_id` value `targetNuhLayerId` greater than 0, the semantics of D.3.22 apply to the output bitstream of the independent non-base layer rewriting process of F.10.2 with the input variables `assignedBaseLayerId` equal to `nestingLayerIdList[i][0]` and `tIdTarget` equal to `MaxTemporalId[i]` for each value of `i` in the range of 0 to `nestingNumOps - 1`, inclusive.

When the decoding unit information SEI message is contained in a bitstream partition nesting SEI message, the following apply:

- The variables `olsIdx`, `psIdx`, and `bspIdx` are set equal to `sei_ols_idx`, `sei_partitioning_scheme_idx`, and `bsp_idx`, respectively, of the bitstream partition nesting SEI message containing this buffering period SEI message, and the `bspIdx`-th bitstream partition of the `psIdx`-th partitioning scheme of the `olsIdx`-th OLS is referred to as the current bitstream partition.
- The variable `maxTId` is set equal to `MaxTemporalId[0]` for the scalable nesting SEI message containing the bitstream partition nesting SEI message containing this buffering period SEI message.
- The variable `hrdParamIdx` is set equal to the value of `bsp_hrd_idx[olsIdx][psIdx][maxTId][i][bspIdx]` for any value of `i` in the range of 0 to `BspSchedCnt[olsIdx][psIdx][maxTId] - 1`, inclusive.
- The following applies for the syntax and semantics of the decoding unit information SEI message:

- The syntax elements `sub_pic_hrd_params_present_flag`, `sub_pic_cpb_params_in_pic_timing_sei_flag`, and `dpb_output_delay_du_length_minus1`, and the variable `CpbDpbDelaysPresentFlag` are found in or derived from syntax elements in the `hrdParamIdx-th hrd_parameters()` syntax structure.
- It is a requirement of bitstream conformance that the values of `sub_pic_hrd_params_present_flag`, `sub_pic_cpb_params_in_pic_timing_sei_flag`, and `dpb_output_delay_du_length_minus1`, and `CpbDpbDelaysPresentFlag` derived using a particular value of `i` for the derivation of `hrdParamIdx` shall be the same as the value of the respective syntax elements or variable derived using any other allowed value of `i`.

The presence of decoding unit information SEI messages for the current bitstream partition is specified as follows on the basis of the syntax elements `sub_pic_hrd_params_present_flag` and `sub_pic_cpb_params_in_pic_timing_sei_flag` and the variable `CpbDpbDelaysPresentFlag` that are found or derived as specified above:

- If `CpbDpbDelaysPresentFlag` is equal to 1, `sub_pic_hrd_params_present_flag` is equal to 1, and `sub_pic_cpb_params_in_pic_timing_sei_flag` is equal to 0, one or more decoding unit information SEI messages applicable to the current bitstream partition shall be associated with each decoding unit of the current bitstream partition in the CVS.
- Otherwise, if `CpbDpbDelaysPresentFlag` is equal to 1, `sub_pic_hrd_params_present_flag` is equal to 1, and `sub_pic_cpb_params_in_pic_timing_sei_flag` is equal to 1, one or more decoding unit information SEI messages applicable to the current bitstream partition may or may not be associated with each decoding unit of the current bitstream partition in the CVS.
- Otherwise (`CpbDpbDelaysPresentFlag` is equal to 0 or `sub_pic_hrd_params_present_flag` is equal to 0), in the CVS there shall be no decoding unit of the current bitstream partition that is associated with a decoding unit information SEI message applicable to the current bitstream partition.

The set of NAL units associated with a decoding unit information SEI message contained in a bitstream partition nesting SEI message consists, in decoding order, of the SEI NAL unit containing the decoding unit information SEI message and all subsequent NAL units in the partition unit up to but not including any subsequent SEI NAL unit containing a decoding unit information SEI message that is contained in a bitstream partition nesting SEI message applying to the current bitstream partition and that has a different value of `decoding_unit_idx`.

It is a requirement of bitstream conformance that all decoding unit information SEI messages that are contained in a bitstream partition nesting SEI message, are associated with the same access unit, apply to the current bitstream partition, and have `dpb_output_du_delay_present_flag` equal to 1 shall have the same value of `pic_spt_dpb_output_du_delay`.

F.14.3.2.7 Scalable nesting SEI message semantics for multi-layer extensions

The specifications of D.3.24 apply with the following modifications.

It is a requirement of bitstream conformance that the following restrictions apply on nesting of SEI messages:

- An SEI message that has `payloadType` equal to 129 (active parameter sets), 132 (decoded picture hash), 133 (scalable nesting), 160 (layers not present), 163 (bitstream partition initial arrival time), 164 (sub-bitstream property), or 166 (overlay information) shall not be directly contained in a scalable nesting SEI message.
- When a scalable nesting SEI message contains a buffering period SEI message, a picture timing SEI message, or a decoding unit information SEI message, the scalable nesting SEI message shall not contain any other SEI message with `payloadType` not equal to 0 (buffering period), 1 (picture timing), or 130 (decoding unit information).

ISO/IEC 23008-2:2017(E)

- When present, an SEI message that has payloadType equal to 162 (bitstream partition nesting) shall be contained within a scalable nesting SEI message.
- When a scalable nesting SEI message contains a bitstream partition nesting SEI message, the scalable nesting SEI message shall not contain any other SEI message.

It is a requirement of bitstream conformance that the following restrictions apply on the value of `bitstream_subset_flag`:

- When the scalable nesting SEI message contains a buffering period SEI message, a picture timing SEI message, a decoding unit information SEI message, or a bitstream partition nesting SEI message, `bitstream_subset_flag` shall be equal to 1.
- When the scalable nesting SEI message contains an SEI message that has payloadType equal to any value among `SingleLayerSeiList`, 161, 165, 167, or 168, `bitstream_subset_flag` shall be equal to 0.

When `nesting_op_idx[i]` is present, the list `nestingLayerIdList[i]` is set equal to `LayerSetLayerIdList[nesting_op_idx[i]]` derived from the active VPS.

When a scalable nesting SEI message contains a bitstream partition nesting SEI message, the following apply:

- `nesting_op_flag` shall be equal to 1, `default_op_flag` shall be equal to 0, `nesting_num_ops_minus1` shall be equal to 0, and `nesting_op_idx[0]` shall not be equal to 0.
- The `nuh_layer_id` of the SEI NAL unit containing the scalable nesting SEI message shall be equal to the highest value within the list `nestingLayerIdList[0]`.

When a scalable nesting SEI message directly contains a buffering period SEI message, a picture timing SEI message, or a decoding unit information SEI message, and the `nuh_layer_id` value of the SEI NAL unit containing the scalable nesting SEI message is greater than 0, it is a requirement of bitstream conformance that for any value of `i` in the range of `default_op_flag` to `nesting_num_ops_minus1`, inclusive, the `nesting_op_idx[i]`-th OLS consists of only the layer with `nuh_layer_id` equal to `nestingLayerIdList[i][0]`, the profile of that layer is a profile specified in Annex A, and the value of `general_inbld_flag` (when `MaxTemporalId[i]` is equal to `vps_max_sub_layers_minus1`) or the value of `sub_layer_inbld_flag[tidTarget]` (when `MaxTemporalId[i]` is less than `vps_max_sub_layers_minus1`) in the `profile_tier_level()` syntax structure associated with that layer is equal to 1.

NOTE In other words, buffering period, picture timing, or decoding unit information SEI messages that are directly nested in an SEI NAL unit with `nuh_layer_id` greater than 0 can only be present for rewritable independent non-base layers.

F.14.3.2.8 Region refresh information SEI message semantics for multi-layer extensions

The region refresh information SEI message indicates whether the slice segments that the current SEI message applies to belong to a refreshed region of the current picture.

The variable `targetLayerIdList` is derived as follows:

- If the region refresh information SEI message applies to the current layer and all the reference layers, `targetLayerIdList` contains the `nuh_layer_id` of the current layer and all the reference layers.
- Otherwise, `targetLayerIdList` contains the `nuh_layer_id` of the current layer.

The region refresh SEI message is associated with a recovery point SEI message that applies to `targetLayerIdList`.

A picture that is not an IRAP picture, that belongs to a layer, and that is contained in an access unit containing a recovery point SEI message where the recovery point SEI message applies to that layer is referred to as a gradual decoding refresh (GDR) picture, and the access unit containing the picture is

referred to as a GDR access unit. The access unit corresponding to the indicated recovery point picture is referred to as the recovery point access unit.

If there is a picture `picB` in the current layer that follows the GDR picture `picA` in the current layer in decoding order in the CVS and `PicOrderCnt(picB)` is equal to `PicOrderCnt(picA)` plus the value of `recovery_poc_cnt` in the recovery point SEI message, where `PicOrderCnt(picA)` and `PicOrderCnt(picB)` are the `PicOrderCntVal` values of `picA` and `picB`, respectively, immediately after the invocation of the decoding process for picture order count for `picB`, let the variable `lastPicInSet` be the recovery point picture. Otherwise, let `lastPicInSet` be the picture in `targetLayerIdList` that immediately precedes the recovery point picture in output order. The picture `lastPicInSet` shall not precede the GDR access unit in decoding order.

Let `gdrPicSet` be the set of pictures in `targetLayerIdList` starting from a GDR access unit to the access unit containing `lastPicInSet`, inclusive, in output order. When the decoding process for the current layer is started from a GDR access unit, the refreshed region in each picture of the `gdrPicSet` is indicated to be the region of the picture that is correct or approximately correct in content, and, when `lastPicInSet` is contained in the recovery point access unit, the refreshed region in `lastPicInSet` covers the entire picture.

The slice segments of the current picture to which a region refresh information SEI message applies consist of all slice segments within the picture that follow the SEI NAL unit containing the region refresh information SEI message and precede the next SEI NAL unit, in decoding order, containing a region refresh information SEI message (if any) that has the same `targetLayerIdList` as the current SEI message. These slice segments are referred to as the slice segments associated with the region refresh information SEI message.

Let `gdrAuSet` be the set of access units corresponding to `gdrPicSet`. A `gdrAuSet` and the corresponding `gdrPicSet` are referred to as being associated with the recovery point SEI message contained in the GDR access unit.

Region refresh information SEI messages shall not be present in an access unit unless the access unit is included in a `gdrAuSet` associated with a recovery point SEI message. When any picture that is included in a `gdrPicSet` is associated with one or more region refresh information SEI messages, all pictures in the `gdrPicSet` shall be associated with one or more region refresh information SEI messages.

refreshed_region_flag equal to 1 indicates that the slice segments associated with the current SEI message belong to the refreshed region in the current picture. **refreshed_region_flag** equal to 0 indicates that the slice segments associated with the current SEI message may not belong to the refreshed region in the current picture.

When one or more region refresh information SEI messages are associated with a picture belonging to `gdrPicSet` and the first slice segment of the picture in decoding order does not have an associated region refresh information SEI message, the value of **refreshed_region_flag** for the slice segments of the picture that precede the first region refresh information SEI message is inferred to be equal to 0.

When `lastPicInSet` is the recovery point picture, and any region refresh SEI message is associated with the recovery point access unit, the first slice segment of the picture in decoding order shall have an associated region refresh SEI message, and the value of **refreshed_region_flag** shall be equal to 1 in all region refresh SEI messages associated with the picture.

When one or more region refresh information SEI messages are associated with a picture, the refreshed region in the picture is specified as the set of CTUs in all slice segments of the picture that are associated with region refresh information SEI messages that have **refreshed_region_flag** equal to 1. Other slice segments belong to the non-refreshed region of the picture.

It is a requirement of bitstream conformance that when a dependent slice segment belongs to the refreshed region, the preceding slice segment in decoding order shall also belong to the refreshed region.

Let `gdrRefreshedSliceSegmentSet` be the set of all slice segments that belong to the refreshed regions in the `gdrPicSet`. The variable `upSwitchingRefreshedSliceSegmentSet` is derived as follows:

ISO/IEC 23008-2:2017(E)

- If `targetLayerIdList` contains only one non-zero `nuh_layer_id`, `upSwitchingRefreshedSliceSegmentSet` is defined as the set inclusive of the following:
 - all slice segments of all pictures of the reference layers that precede, in decoding order, the current picture and that may be used for reference by the current picture or subsequent pictures of the reference layers.
 - all slice segments of all pictures of the reference layers that succeed, in decoding order, the current picture and that belong to `gdrAuSet`.
- Otherwise, `upSwitchingRefreshedSliceSegmentSet` is defined as an empty set.

When a `gdrPicSet` contains one or more pictures associated with region refresh information SEI messages, it is a requirement of bitstream conformance that the following constraints all apply:

- For each layer in `targetLayerIdList`, the refreshed region in the first picture, in decoding order, that belongs to the layer and that is included in `gdrPicSet` that contains any refreshed region shall contain only coding units that are coded in an intra coding mode or inter-layer prediction from slice segments belonging to the union of `gdrRefreshedSliceSegmentSet` and `upSwitchingRefreshedSliceSegmentSet`.
- For each picture included in the `gdrPicSet`, the syntax elements in `gdrRefreshedSliceSegmentSet` shall be constrained such that no samples or motion vector values outside of the union of `gdrRefreshedSliceSegmentSet` and `upSwitchingRefreshedSliceSegmentSet` are used for inter prediction or inter-layer prediction in the decoding process of any samples within `gdrRefreshedSliceSegmentSet`.
- For any picture that follows the picture `lastPicInSet` in output order, the syntax elements in the slice segments of the picture shall be constrained such that no samples or motion vector values outside of the union of `gdrRefreshedSliceSegmentSet` and `upSwitchingRefreshedSliceSegmentSet` are used for inter prediction or inter-layer prediction in the decoding process of the picture other than those of the other pictures that follow the picture `lastPicInSet` in output order.

F.14.3.2.9 Coded region completion SEI message semantics for multi-layer extensions

The specifications of D.3.37 apply with the following additions.

The `nuh_layer_id` value of the SEI NAL unit containing a coded region completion SEI message shall be equal to the `nuh_layer_id` value of the associated VCL NAL unit for the SEI NAL unit.

When an access unit contains one or more layers not present SEI messages, any coded region completion SEI message with `next_segment_address` equal to 0 in that access unit shall follow the first layers not present SEI message, in decoding order, that is present in that access unit.

NOTE The specifications given in F.7.4.2.4.4 for associating NAL units to access units facilitate determining of an end of an access unit when the first NAL unit of the next access unit is available. Some implementations may operate on access unit basis, e.g. when inputting NAL units to a decoder. The latency in such implementations is potentially reduced, when a bitstream includes multiple layers and an end of an access unit for the OLS with index `trgtOlsIdx` is concluded as follows in response to decoding a coded region completion SEI message with `next_segment_address` equal to 0:

- The variable `layerMaybePresent[layerIdx]` is derived as follows:
 - If a layers not present SEI message is present in the current CVS and precedes the coded region completion SEI message in decoding order, `layerMaybePresentFlag[layerIdx]` is set equal to `!layer_not_present_flag[layerIdx]` of the previous layers not present SEI message, in decoding order, for each value of `layerIdx` from 0 to `MaxLayersMinus1`, inclusive.

- Otherwise, `layerMayBePresentFlag[layerIdx]` is set equal to 1 for each value of `layerIdx` from 0 to `MaxLayersMinus1`, inclusive.
- Let a set of `nuh_layer_id` values `trgtLayerIdList` of the necessary layers for an OLS with index `trgtOlsIdx` be equal to `TargetDecLayerIdList` derived using Formula (F-57) by setting `TargetOlsIdx` equal to `trgtOlsIdx`.
- Let `numTrgtLayerIds` be equal to the number of `nuh_layer_id` values in `trgtLayerIdList`.
- Let `currLayerId` be equal to the `nuh_layer_id` value of the VCL NAL unit associated with the SEI NAL unit containing this coded region completion SEI message.
- Let `prevNecessaryLayerTrgtIdx` be the index of the greatest value within `trgtLayerIdList` that is less than or equal to `currLayerId`.
- When one of the following is true, there are no VCL NAL units of any necessary layer of the OLS with index `trgtOlsIdx` following, in decoding order, the VCL NAL unit associated with the SEI NAL unit containing this SEI message within the current access unit:
 - `currLayerId` is greater than or equal to any value in `trgtLayerIdList`.
 - `layerMayBePresentFlag[LayerIdxInVps[layerId]]` is equal to 0 for all the values of `layerId` equal to `trgtLayerIdList[trgtIdx]` for each `trgtIdx` in the range of `prevNecessaryLayerTrgtIdx + 1` to `numTrgtLayerIds - 1`, inclusive.

F.14.3.3 Layers not present SEI message semantics

The layers not present SEI message provides a mechanism for signalling that VCL NAL units of particular layers indicated by the VPS are not present in a particular set of access units.

The target access units are defined as the set of access units starting from the access unit containing the layers not present SEI message up to but not including the next access unit, in decoding order, that contains a layers not present SEI message or the end of the CVS, whichever is earlier in decoding order.

When present, the layers not present SEI message applies to the target access units.

When a layers not present SEI message is associated with a coded picture with `TemporalId firstTid` that is greater than 0 and that coded picture is followed, in decoding order, by any coded picture with `TemporalId` less than `firstTid` in the same CVS, a layers not present SEI message shall be present for the next coded picture, in decoding order, with `TemporalId` less than `firstTid`.

`lnp_sei_active_vps_id` identifies the active VPS of the CVS containing the layers not present SEI message. The value of `lnp_sei_active_vps_id` shall be equal to the value of `vps_video_parameter_set_id` of the active VPS for the VCL NAL units of the access unit containing the SEI message.

`layer_not_present_flag[i]` equal to 1 indicates that there are no VCL NAL units with `nuh_layer_id` equal to `layer_id_in_nuh[i]` present in the target access units. `layer_not_present_flag[i]` equal to 0 indicates that there may or may not be VCL NAL units with `nuh_layer_id` equal to `layer_id_in_nuh[i]` present in the target access units.

When `layer_not_present_flag[i]` is equal to 1 and `i` is less than `MaxLayersMinus1`, `layer_not_present_flag[LayerIdxInVps[IdPredictedLayer[layer_id_in_nuh[i]][j]]]` shall be equal to 1 for all values of `j` in the range of 0 to `NumPredictedLayers[layer_id_in_nuh[i]] - 1`, inclusive.

F.14.3.4 Inter-layer constrained tile sets SEI message semantics

The scope of the inter-layer constrained tile sets SEI message is a complete CLVS of the layer with `nuh_layer_id` equal to `targetLayerId`. When an inter-layer constrained tile sets SEI message is present for any coded picture of a CLVS and the first coded picture of the CLVS in decoding order is an IRAP picture, the inter-layer constrained tile sets SEI message shall be present for the first coded picture of the CLVS in decoding order and may also be present for other coded pictures of the CLVS.

ISO/IEC 23008-2:2017(E)

The inter-layer constrained tile sets SEI message shall not be present for the layer with `nuh_layer_id` equal to `targetLayerId` when `tiles_enabled_flag` is equal to 0 for any PPS that is active for the pictures of the CLVS of the layer with `nuh_layer_id` equal to `targetLayerId`.

The inter-layer constrained tile sets SEI message shall not be present for the layer with `nuh_layer_id` equal to `targetLayerId` unless every PPS that is active for the pictures of the CLVS of the layer with `nuh_layer_id` equal to `targetLayerId` has `tile_boundaries_aligned_flag` equal to 1 or fulfills the conditions that would be indicated by `tile_boundaries_aligned_flag` being equal to 1.

An identified tile set is defined as a set of tiles within a picture with `nuh_layer_id` equal to `targetLayerId` that contains the tiles specified below on the basis of the values of the syntax elements contained in the inter-layer constrained tile sets SEI message.

An associated reference tile set for the `iPred`-th identified tile set with `ilcts_id[iPred]` equal to `ilctsId`, if any, is defined as the identified tile set present in the same access unit as the `iPred`-th identified tile set and associated with `ilcts_id[iRef]` equal to `ilctsId` and `nuh_layer_id` equal to `IdDirectRefLayer[targetLayerId][j]` for any value of `j` in the range of 0 to `NumDirectRefLayers[targetLayerId] - 1`, inclusive.

The presence of the inter-layer constrained tile sets SEI message indicates that the inter-layer prediction process is constrained such that no sample value outside each associated reference tile set, and no sample value at a fractional sample position that is derived using one or more sample values outside each associated reference tile set, is used for inter-layer prediction of any sample within the identified tile set.

NOTE 1 When loop filtering and resampling filter are applied across tile boundaries, inter-layer prediction of any samples within an identified tile set that refers to samples within 8 samples from an associated reference tile set boundary that is not also a picture boundary may result in propagation of mismatch error. An encoder can avoid such potential error propagation by avoiding the use of motion vectors that cause such references.

When more than one inter-layer constrained tile sets SEI message is present for a CLVS, they shall contain identical content.

The number of inter-layer constrained tile sets SEI messages for the same CLVS in each access unit shall not exceed 5.

`il_all_tiles_exact_sample_value_match_flag` equal to 1 indicates that, within the CLVS, when the coding tree blocks that are outside of any tile in any identified tile set specified in this inter-layer constrained tile sets SEI message are not decoded and the boundaries of the tile is treated as picture boundaries for purposes of the decoding process, the value of each sample in the tile would be exactly the same as the value of the sample that would be obtained when all the coding tree blocks of all pictures in the CLVS are decoded. `il_all_tiles_exact_sample_value_match_flag` equal to 0 indicates that, within the CLVS, when the coding tree blocks that are outside of any tile in any identified tile set specified in this inter-layer constrained tile sets SEI message are not decoded and the boundaries of the tile is treated as picture boundaries for purposes of the decoding process, the value of each sample in the tile may or may not be exactly the same as the value of the same sample when all the coding tree blocks of all pictures in the CLVS are decoded.

`il_one_tile_per_tile_set_flag` equal to 1 indicates that each identified tile set contains one tile, and `il_num_sets_in_message_minus1` is not present.

It is a requirement of bitstream conformance that when `il_one_tile_per_tile_set_flag` is equal to 1, the value of $(\text{num_tile_columns_minus1} + 1) * (\text{num_tile_rows_minus1} + 1)$ shall be less than or equal to 256.

When `il_one_tile_per_tile_set_flag` is equal to 0, the identified tile sets are signalled explicitly.

`il_num_sets_in_message_minus1` plus 1 specifies the number of the identified tile sets in the SEI message. The value of `il_num_sets_in_message_minus1` shall be in the range of 0 to 255, inclusive.

`skipped_tile_set_present_flag` equal to 1 indicates that, within the CLVS, the `il_num_sets_in_message_minus1`-th identified tile set consists of those remaining tiles that are not

included in any earlier identified tile sets in the same message and all the prediction blocks that are inside the $il_num_sets_in_message_minus1$ -th identified tile set are inter-layer predicted from inter-layer reference pictures with nuh_layer_id equal to

$IdDirectRefLayer[targetLayerId][NumDirectRefLayers[targetLayerId] - 1]$ and no `residual_coding()` syntax structure is present in any transform unit of the $il_num_sets_in_message_minus1$ -th identified tile set. `skipped_tile_set_present_flag` equal to 0 does not indicate a bitstream constraint within the CLVS. When not present, the value of `skipped_tile_set_present_flag` is inferred to be equal to 0.

$ilcts_id[i]$ contains an identifying number that may be used to identify the purpose of the i -th identified tile set (for example, to identify an area to be extracted from the coded video sequence for a particular purpose). The value of $ilcts_id[i]$ shall be in the range of 0 to $2^{32} - 2$, inclusive.

Values of $ilcts_id[i]$ from 0 to 255, inclusive, and from 512 to $2^{31} - 1$, inclusive, may be used as determined by the application. If `il_one_tile_per_tile_set_flag` is equal to 1, values of $ilcts_id[i]$ from 256 to 511, inclusive, are used for the inferred $ilcts_id[i]$ values as specified above. Otherwise, values of $ilcts_id[i]$ from 256 to 511, inclusive, are reserved for future use by ITU-T | ISO/IEC. Values of $ilcts_id[i]$ from 2^{31} to $2^{32} - 2$, inclusive, are reserved for future use by ITU-T | ISO/IEC. Decoders encountering an indicated value of $ilcts_id[i]$ in the range of 256 to 511, inclusive, or in the range of 2^{31} to $2^{32} - 2$, inclusive, shall ignore (remove from the bitstream and discard) it.

When $ilcts_id[i]$ is not present for i in the range of 0 to $(num_tile_columns_minus1 + 1) * (num_tile_rows_minus1 + 1) - 1$, inclusive, due to `il_one_tile_per_tile_set_flag` being equal to 1, it is inferred to be equal to $256 + i$.

$il_num_tile_rects_in_set_minus1[i]$ plus 1 specifies the number of rectangular regions of tiles in the i -th identified tile set. The value of $il_num_tile_rects_in_set_minus1[i]$ shall be in the range of 0 to $(num_tile_columns_minus1 + 1) * (num_tile_rows_minus1 + 1) - 1$, inclusive.

$il_top_left_tile_index[i][j]$ and **$il_bottom_right_tile_index[i][j]$** identify the tile position of the top-left tile and the tile position of the bottom-right tile in a rectangular region of the i -th identified tile set, respectively, in tile raster scan order.

$ilc_idc[i]$ equal to 1 indicates that no samples outside of any associated reference tile set and no samples at a fractional sample position that is derived using one or more samples outside of any associated reference tile set are used for inter-layer prediction of any sample within the i -th identified tile set. $ilc_idc[i]$ equal to 2 indicates that no prediction block in the i -th identified tile set is predicted from an inter-layer reference picture. $ilc_idc[i]$ equal to 0 indicates that the inter-layer prediction process may or may not be constrained for the prediction block in the i -th identified tile set. The value of $ilc_idc[i]$ equal to 3 is reserved.

$il_exact_sample_value_match_flag[i]$ equal to 1 indicates that, within the CLVS, when the coding tree blocks that do not belong to the i -th identified tile set are not decoded and the boundaries of the i -th identified tile set are treated as picture boundaries for the purposes of the decoding process, the value of each sample in the i -th identified tile set would be exactly the same as the value of the sample that would be obtained when all the coding tree blocks of all pictures in the CLVS are decoded. $il_exact_sample_value_match_flag[i]$ equal to 0 indicates that, within the CLVS, when the coding tree blocks that are outside of the i -th identified tile set are not decoded and the boundaries of the i -th identified tile set are treated as picture boundaries for the purposes of the decoding process, the value of each sample in the i -th identified tile set may or may not be exactly the same as the value of the same sample when all the coding tree blocks of all pictures in the CLVS are decoded.

NOTE 2 It is feasible to use `il_exact_sample_value_match_flag` equal to 1 when using certain combinations of `loop_filter_across_tiles_enabled_flag`, `pps_loop_filter_across_slices_enabled_flag`, `pps_deblocking_filter_disabled_flag`, `slice_loop_filter_across_slices_enabled_flag`, `slice_deblocking_filter_disabled_flag`, `sample_adaptive_offset_enabled_flag`, `slice_sao_luma_flag`, and `slice_sao_chroma_flag`.

$all_tiles_ilc_idc$ equal to 1 indicates that, for each identified tile set within the CLVS, no sample value outside of each associated reference tile set and no sample value at a fractional sample position that is derived using one or more samples outside of each associated reference tile set is used for inter-layer

prediction of any sample within the identified tile set. `all_tiles_ilc_idc` equal to 2 indicates that, within the CLVS, no prediction block in each identified tile set is predicted from an inter-layer reference picture. `all_tiles_ilc_idc` equal to 0 indicates that, within the CLVS, the inter-layer prediction process may or may not be constrained for the identified tile sets. The value of `all_tiles_ilc_idc` equal to 3 is reserved. When `all_tiles_ilc_idc` is not present, it is inferred to be equal to 0.

F.14.3.5 Bitstream partition nesting SEI message semantics

The bitstream partition nesting SEI message provides a mechanism to associate SEI messages with a bitstream partition of a partitioning scheme of an OLS.

NOTE The bitstream partition nesting SEI message is contained within a scalable nesting SEI message. Constraints on the scalable nesting SEI message containing a bitstream partition nesting SEI message are specified in F.14.3.2.7.

A bitstream partition nesting SEI message contains one or more SEI messages.

`sei_ols_idx` specifies the index of the OLS to which the contained SEI messages apply. The value of `sei_ols_idx` shall be in the range of 0 to `NumOutputLayerSets - 1`, inclusive.

It is a requirement of bitstream conformance that `OlsIdxToLsIdx[sei_ols_idx]` shall be equal to `nesting_op_idx[0]` of the scalable nesting SEI message that contains the bitstream partition nesting SEI message.

`sei_partitioning_scheme_idx` specifies the index of the partitioning scheme to which the contained SEI messages apply. The value of `sei_partitioning_scheme_idx` shall be in the range of 0 to `num_signalled_partitioning_schemes[sei_ols_idx]`, inclusive.

`bsp_idx` specifies the index of the bitstream partition to which the contained SEI messages apply. The value of `bsp_idx` shall be in the range of 0 to `num_partitions_in_scheme_minus1[sei_ols_idx][sei_partitioning_scheme_idx]`, inclusive.

`num_seis_in_bsp_minus1` plus 1 specifies the number of `sei_message()` syntax structures contained in the `bsp_nesting()` syntax structure. The value of `num_seis_in_bsp_minus1` shall be in the range of 0 to 63, inclusive.

`bsp_nesting_zero_bit` shall be equal to 0.

F.14.3.6 Bitstream partition initial arrival time SEI message semantics

The bitstream partition initial arrival time SEI message specifies the initial arrival times to be used in the bitstream-partition-specific CPB operation.

When present, this SEI message shall be contained within a bitstream partition nesting SEI message that is contained in a scalable nesting SEI message, and the same bitstream partition nesting SEI message shall also contain a buffering period SEI message.

The following apply for each value of `i` in the range of 0 to `BspSchedCnt[olsIdx][psIdx][MaxTemporalId[0]] - 1`, inclusive:

- The variable `hrdParamIdx[i]` is set equal to the value of `bsp_hrd_idx[olsIdx][psIdx][maxTemporalId[0]][i][bspIdx]`, where `olsIdx`, `psIdx`, and `bspIdx` are equal to `sei_ols_idx`, `sei_partitioning_scheme_idx`, and `bsp_idx`, respectively, of the bitstream partition nesting SEI message containing this bitstream partition initial arrival time SEI message, and `maxTemporalId[0]` is the value of `MaxTemporalId[0]` for the scalable nesting SEI message containing the bitstream partition nesting SEI message containing this bitstream partition initial arrival time SEI message.
- The variable `initialCpbRemovalDelayLength[i]` is set equal to `initial_cpb_removal_delay_length_minus1 + 1`, where `initial_cpb_removal_delay_length_minus1` is found in the `hrdParamIdx[i]`-th `hrd_parameters()` syntax structure in the active VPS.

- The variable `nalHrdParamsPresent[i]` is set equal to the value of `nal_hrd_parameters_present_flag` in the `hrdParamIdx[i]`-th `hrd_parameters()` syntax structure in the active VPS.
- The variable `vclHrdParamsPresent[i]` is set equal to the value of `vcl_hrd_parameters_present_flag` in the `hrdParamIdx[i]`-th `hrd_parameters()` syntax structure in the active VPS.

It is a requirement of bitstream conformance that the value of `nalHrdParamsPresent[i]` shall be the same for all values of `i` in the range of 0 to `BspSchedCnt[olsIdx][psIdx][MaxTemporalId[0]] - 1`, inclusive.

It is a requirement of bitstream conformance that the value of `vclHrdParamsPresent[i]` shall be the same for all values of `i` in the range of 0 to `BspSchedCnt[olsIdx][psIdx][MaxTemporalId[0]] - 1`, inclusive.

The variable `nalInitialArrivalDelayPresent` is set equal to `nalHrdParamsPresent[i]` of any value of `i` in the range of 0 to `BspSchedCnt[olsIdx][psIdx][MaxTemporalId[0]] - 1`, inclusive.

The variable `vclInitialArrivalDelayPresent` is set equal to `vclHrdParamsPresent[i]` of any value of `i` in the range of 0 to `BspSchedCnt[olsIdx][psIdx][MaxTemporalId[0]] - 1`, inclusive.

nal_initial_arrival_delay[i] specifies the initial arrival time for the `i`-th delivery schedule of the bitstream partition to which this SEI message applies, when NAL HRD parameters are in use. The length, in bits, of the `nal_initial_arrival_delay[i]` syntax element is equal to `initialCpbRemovalDelayLength[i]`.

vcl_initial_arrival_delay[i] specifies the initial arrival time for the `i`-th delivery schedule of the bitstream partition to which this SEI message applies, when VCL HRD parameters are in use. The length, in bits, of the `vcl_initial_arrival_delay[i]` syntax element is equal to `initialCpbRemovalDelayLength[i]`.

F.14.3.7 Sub-bitstream property SEI message semantics

The sub-bitstream property SEI message, when present, provides the bit rate information for a sub-bitstream created by discarding those pictures in the layers that do not belong to the output layers of the OLSs specified by the active VPS and that do not affect the decoding of the output layers.

When present, the sub-bitstream property SEI message shall be associated with an initial IRAP access unit, and the information provided by the SEI messages applies to the bitstream corresponding to the CVS containing the associated initial IRAP access unit.

sb_property_active_vps_id identifies the active VPS. The value of `sb_property_active_vps_id` shall be equal to the value of `vps_video_parameter_set_id` of the active VPS referred to by the VCL NAL units of the associated access unit.

num_additional_sub_streams_minus1 plus 1 specifies the number of the sub-bitstreams for which the bit rate information may be provided by this SEI message. The value of `num_additional_sub_streams_minus1` shall be in the range of 0 to $2^{10} - 1$, inclusive.

sub_bitstream_mode[i] specifies how the `i`-th sub-bitstream is generated. The value of `sub_bitstream_mode[i]` shall be equal to 0 or 1, inclusive. The values 2 and 3 are reserved for future use by ITU-T and ISO/IEC. When `sub_bitstream_mode[i]` is the greater than 1, decoders shall ignore the syntax elements `ols_idx_to_vps[i]`, `highest_sublayer_id[i]`, `avg_sb_property_bit_rate[i]`, and `max_sb_property_bit_rate[i]`.

When `sub_bitstream_mode[i]` is equal to 0, the `i`-th sub-bitstream is generated as follows:

- Let `lsIdx` be equal to `OlsIdxToLsIdx[ols_idx_to_vps[i]]`.
- A sub-bitstream `subBitstream[i]` is first created as follows:

- If `lsIdx` is less than or equal to `vps_num_layer_sets_minus1` and `vps_base_layer_internal_flag` is equal to 1, the sub-bitstream extraction process as specified in Clause 10 is invoked with the bitstream corresponding to the CVS containing the sub-bitstream property SEI message, `highest_sublayer_id[i]`, and `LayerSetLayerIdList[lsIdx]` as inputs, and the output is assigned to `subBitstream[i]`.
- Otherwise, if `lsIdx` is less than or equal to `vps_num_layer_sets_minus1` and `vps_base_layer_internal_flag` is equal to 0, the sub-bitstream extraction process as specified in F.10.1 is invoked with the bitstream corresponding to the CVS containing the sub-bitstream property SEI message, `highest_sublayer_id[i]`, and `LayerSetLayerIdList[lsIdx]` as inputs, and the output is assigned to `subBitstream[i]`.
- Otherwise, the sub-bitstream extraction process as specified in F.10.3 is invoked with the bitstream corresponding to the CVS containing the sub-bitstream property SEI message, `highest_sublayer_id[i]`, and `LayerSetLayerIdList[lsIdx]` as inputs, and the output is assigned to `subBitstream[i]`.
- Remove all NAL units for which the `nuh_layer_id` is not included in `TargetOptLayerIdList` and either of the following conditions is true:
 - The value of `nal_unit_type` is not in the range of `BLA_W_LP` to `BSV_IRAP_VCL23`, inclusive, and `max_tid_il_ref_pics_plus1[LayerIdxInVps[nuh_layer_id]][LayerIdxInVps[layerId]]` is equal to 0 for `layerId` values included in `TargetOptLayerIdList`.
 - `TemporalId` is greater than the maximum value of `max_tid_il_ref_pics_plus1[LayerIdxInVps[nuh_layer_id]][LayerIdxInVps[layerId]] - 1` for all `layerId` values included in `TargetOptLayerIdList`.

When `sub_bitstream_mode[i]` is equal to 1, the *i*-th sub-bitstream is generated as specified by the above process, followed by:

- Remove all NAL units with `nuh_layer_id` not among the values included in `TargetOptLayerIdList` and with `discardable_flag` equal to 1.

`ols_idx_to_vps[i]` specifies the index of the OLS corresponding to the *i*-th sub-bitstream. The value of `ols_idx_to_vps[i]` shall be in the range of 0 to `NumOutputLayerSets - 1`, inclusive.

`highest_sublayer_id[i]` specifies the highest `TemporalId` of access units in the *i*-th sub-bitstream.

`avg_sb_property_bit_rate[i]` indicates the average bit rate of the *i*-th sub-bitstream, in bits per second. The value is given by `BitRateBPS(avg_sb_property_bit_rate[i])` with the function `BitRateBPS()` being specified as follows:

$$\text{BitRateBPS}(x) = (x \& (2^{14} - 1)) * 10^{(2 + (x \gg 14))} \quad (\text{F-91})$$

The average bit rate is derived according to the access unit removal time specified in F.13. In the following, `bTotal` is the number of bits in all NAL units of the *i*-th sub-bitstream, `t1` is the removal time (in seconds) of the first access unit to which the VPS applies, and `t2` is the removal time (in seconds) of the last access unit (in decoding order) to which the VPS applies. With `x` specifying the value of `avg_sb_property_bit_rate[i]`, the following apply:

- If `t1` is not equal to `t2`, the following condition shall be true:

$$(x \& (2^{14} - 1)) = \text{Round}(b\text{Total} \div ((t_2 - t_1) * 10^{(2 + (x \gg 14))})) \quad (\text{F-92})$$

- Otherwise (`t1` is equal to `t2`), the following condition shall be true:

$$(x \& (2^{14} - 1)) = 0 \quad (\text{F-93})$$

max_sb_property_bit_rate[*i*] indicates an upper bound for the bit rate of the *i*-th sub-bitstream in any one-second time window of access unit removal time as specified in F.13. The upper bound for the bit rate in bits per second is given by $\text{BitRateBPS}(\text{max_sb_property_bit_rate}[i])$. The bit rate values are derived according to the access unit removal time specified in F.13. In the following, t_1 is any point in time (in seconds), t_2 is set equal to $t_1 + 1 \div 100$, and b_{Total} is the number of bits in all NAL units of access units with a removal time greater than or equal to t_1 and less than t_2 . With x specifying the value of $\text{max_sb_property_bit_rate}[i]$, the following condition shall be obeyed for all values of t_1 :

$$(x \times (2^{14} - 1)) \geq b_{\text{Total}} \div ((t_2 - t_1) * 10^{(2 + (x \gg 14))}) \quad (\text{F-94})$$

F.14.3.8 Alpha channel information SEI message semantics

The alpha channel information SEI message provides information about alpha channel sample values and post-processing applied to the decoded alpha planes coded in auxiliary pictures of type AUX_ALPHA, and one or more associated primary pictures.

For an auxiliary picture with `nuh_layer_id` equal to `nuhLayerIdA` and `AuxId[nuhLayerIdA]` equal to AUX_ALPHA, an associated primary picture, if any, is a picture in the same access unit having `AuxId[nuhLayerIdB]` equal to 0 such that `ScalabilityId[LayerIdxInVps[nuhLayerIdA]][j]` is equal to `ScalabilityId[LayerIdxInVps[nuhLayerIdB]][j]` for all values of *j* in the range of 0 to 2, inclusive, and 4 to 15, inclusive.

When an access unit contains an auxiliary picture `picA` with `nuh_layer_id` equal to `nuhLayerIdA` and `AuxId[nuhLayerIdA]` equal to AUX_ALPHA, the alpha channel sample values of `picA` persist in output order until one or more of the following conditions are true:

- The next picture, in output order, with `nuh_layer_id` equal to `nuhLayerIdA` is output.
- A CLVS containing the auxiliary picture `picA` ends.
- The bitstream ends.
- A CLVS of any associated primary layer of the auxiliary picture layer with `nuh_layer_id` equal to `nuhLayerIdA` ends.

The following semantics apply separately to each `nuh_layer_id` `targetLayerId` among the `nuh_layer_id` values to which the alpha channel information SEI message applies.

alpha_channel_cancel_flag equal to 1 indicates that the alpha channel information SEI message cancels the persistence of any previous alpha channel information SEI message in output order that applies to the current layer. **alpha_channel_cancel_flag** equal to 0 indicates that alpha channel information follows.

Let `currPic` be the picture that the alpha channel information SEI message is associated with. The semantics of alpha channel information SEI message persist for the current layer in output order until one or more of the following conditions are true:

- A new CLVS of the current layer begins.
- The bitstream ends.
- A picture `picB` with `nuh_layer_id` equal to `targetLayerId` in an access unit containing an alpha channel information SEI message with `nuh_layer_id` equal to `targetLayerId` is output having `PicOrderCnt(picB)` greater than `PicOrderCnt(currPic)`, where `PicOrderCnt(picB)` and `PicOrderCnt(currPic)` are the `PicOrderCntVal` values of `picB` and `currPic`, respectively, immediately after the invocation of the decoding process for picture order count for `picB`.

alpha_channel_use_idc equal to 0 indicates that for alpha blending purposes the decoded samples of the associated primary picture should be multiplied by the interpretation sample values of the auxiliary

coded picture in the display process after output from the decoding process. `alpha_channel_use_idc` equal to 1 indicates that for alpha blending purposes the decoded samples of the associated primary picture should not be multiplied by the interpretation sample values of the auxiliary coded picture in the display process after output from the decoding process. `alpha_channel_use_idc` equal to 2 indicates that the usage of the auxiliary picture is unspecified. Values greater than 2 for `alpha_channel_use_idc` are reserved for future use by ITU-T | ISO/IEC. When not present, the value of `alpha_channel_use_idc` is inferred to be equal to 2.

`alpha_channel_bit_depth_minus8` plus 8 specifies the bit depth of the samples of the luma sample array of the auxiliary picture. `alpha_channel_bit_depth_minus8` shall be in the range 0 to 7 inclusive. `alpha_channel_bit_depth_minus8` shall be equal to `bit_depth_luma_minus8` of the associated primary picture.

`alpha_transparent_value` specifies the interpretation sample value of an auxiliary coded picture luma sample for which the associated luma and chroma samples of the primary coded picture are considered transparent for purposes of alpha blending. The number of bits used for the representation of the `alpha_transparent_value` syntax element is `alpha_channel_bit_depth_minus8` + 9.

`alpha_opaque_value` specifies the interpretation sample value of an auxiliary coded picture luma sample for which the associated luma and chroma samples of the primary coded picture are considered opaque for purposes of alpha blending. The number of bits used for the representation of the `alpha_opaque_value` syntax element is `alpha_channel_bit_depth_minus8` + 9.

`alpha_channel_incr_flag` equal to 0 indicates that the interpretation sample value for each decoded auxiliary picture luma sample value is equal to the decoded auxiliary picture sample value for purposes of alpha blending. `alpha_channel_incr_flag` equal to 1 indicates that, for purposes of alpha blending, after decoding the auxiliary picture samples, any auxiliary picture luma sample value that is greater than $\text{Min}(\text{alpha_opaque_value}, \text{alpha_transparent_value})$ should be increased by one to obtain the interpretation sample value for the auxiliary picture sample, and any auxiliary picture luma sample value that is less than or equal to $\text{Min}(\text{alpha_opaque_value}, \text{alpha_transparent_value})$ should be used without alteration as the interpretation sample value for the decoded auxiliary picture sample value. When not present, the value of `alpha_channel_incr_flag` is inferred to be equal to 0.

`alpha_channel_clip_flag` equal to 0 indicates that no clipping operation is applied to obtain the interpretation sample values of the decoded auxiliary picture. `alpha_channel_clip_flag` equal to 1 indicates that the interpretation sample values of the decoded auxiliary picture are altered according to the clipping process described by the `alpha_channel_clip_type_flag` syntax element. When not present, the value of `alpha_channel_clip_flag` is inferred to be equal to 0.

`alpha_channel_clip_type_flag` equal to 0 indicates that, for purposes of alpha blending, after decoding the auxiliary picture samples, any auxiliary picture luma sample that is greater than $(\text{alpha_opaque_value} - \text{alpha_transparent_value}) / 2$ is set equal to `alpha_opaque_value` to obtain the interpretation sample value for the auxiliary picture luma sample, and any auxiliary picture luma sample that is less or equal than $(\text{alpha_opaque_value} - \text{alpha_transparent_value}) / 2$ is set equal to `alpha_transparent_value` to obtain the interpretation sample value for the auxiliary picture luma sample. `alpha_channel_clip_type_flag` equal to 1 indicates that, for purposes of alpha blending, after decoding the auxiliary picture samples, any auxiliary picture luma sample that is greater than `alpha_opaque_value` is set equal to `alpha_opaque_value` to obtain the interpretation sample value for the auxiliary picture luma sample, and any auxiliary picture luma sample that is less than or equal to `alpha_transparent_value` is set equal to `alpha_transparent_value` to obtain the interpretation sample value for the auxiliary picture luma sample.

NOTE When both `alpha_channel_incr_flag` and `alpha_channel_clip_flag` are equal to one, the clipping operation specified by `alpha_channel_clip_type_flag` should be applied first followed by the alteration specified by `alpha_channel_incr_flag` to obtain the interpretation sample value for the auxiliary picture luma sample.

F.14.3.9 Overlay information SEI message semantics

The overlay information SEI message provides information about overlay pictures coded as auxiliary pictures. Overlay auxiliary pictures have `nuh_layer_id` equal to `nuhLayerIdA` and `AuxId[nuhLayerIdA]` in the range of 128 to 159, inclusive. Each overlay auxiliary picture layer is associated with one or more primary picture layers as specified below.

overlay_info_cancel_flag equal to 1 indicates that the SEI message cancels the persistence of any previous overlay information SEI message in output order that is associated with one or more primary picture layers to which this SEI applies. `overlay_info_cancel_flag` equal to 0 indicates that overlay information follows.

overlay_content_aux_id_minus128 plus 128 indicates the value of `AuxId` of auxiliary pictures containing overlay content. `overlay_content_aux_id_minus128` shall be in the range of 0 to 31, inclusive.

overlay_label_aux_id_minus128 plus 128 indicates the value of `AuxId` of auxiliary pictures containing overlay label. `overlay_label_aux_id_minus128` shall be in the range of 0 to 31, inclusive.

overlay_alpha_aux_id_minus128 plus 128 indicates the value of `AuxId` of auxiliary pictures containing overlay alpha. `overlay_alpha_aux_id_minus128` shall be in the range of 0 to 31, inclusive.

overlay_element_label_value_length_minus8 plus 8 indicates the number of bits used for coding the `overlay_element_label_min[i][j]` and `overlay_element_label_max[i][j]` syntax elements.

num_overlays_minus1 plus 1 specifies the number of overlays described by the overlay information SEI message. `num_overlays_minus1` shall be in the range of 0 to 15, inclusive.

overlay_idx[i] indicates the index of the *i*-th overlay. `overlay_idx[i]` shall be in the range of 0 to 255, inclusive.

language_overlay_present_flag[i] equal to 1 indicates that `overlay_language[i]` is present. `language_overlay_present_flag[i]` equal to 0 indicates that `overlay_language[i]` is not present and that the language of the overlay is unspecified.

overlay_content_layer_id[i] indicates the `nuh_layer_id` value of the NAL units of the overlay content of the *i*-th overlay. `AuxId[overlay_content_layer_id[i]]` shall be equal to `overlay_content_aux_id_minus128 + 128` for all values of *i* in the range of 0 to `num_overlays_minus1`, inclusive.

The value of the variable `pLid`, which identifies the `nuh_layer_id` value of the primary picture which the *i*-th overlay is associated with, is derived as follows:

```

pLid = -1
for( j = 0; j < 63; j++ )
    if( ViewOrderIdx[ j ] == ViewOrderIdx[ overlay_content_layer_id[ i ] ] &&
        DependencyId[ j ] == DependencyId[ overlay_content_layer_id[ i ] ] && AuxId[ j ] == 0 )
        pLid = j

```

(F-95)

The value of `pLid` shall be in the range of 0 to 62, inclusive.

overlay_label_present_flag[i] equal to 1 specifies that `overlay_label_layer_id[i]` is present. `overlay_label_present_flag[i]` equal to 0 specifies that `overlay_label_layer_id[i]` is not present.

overlay_label_layer_id[i] indicates the `nuh_layer_id` value of NAL units in the overlay label of the *i*-th overlay. `AuxId[overlay_label_layer_id[i]]` shall be equal to `overlay_label_aux_id_minus128 + 128` for all values of *i* in the range of 0 to `num_overlays_minus1`, inclusive.

overlay_alpha_present_flag[i] equal to 1 specifies that `overlay_alpha_layer_id[i]` is present. `overlay_alpha_present_flag[i]` equal to 0 specifies that `overlay_alpha_layer_id[i]` is not present.

overlay_alpha_layer_id[i] indicates the `nuh_layer_id` value of NAL units in the overlay alpha of the *i*-th overlay. `AuxId[overlay_alpha_layer_id[i]]` shall be equal to `overlay_alpha_aux_id_minus128 + 128` for all values of *i* in the range of 0 to `num_overlays_minus1`, inclusive.

num_overlay_elements_minus1[*i*] indicates the number of overlay elements in the *i*-th overlay. **num_overlay_elements_minus1**[*i*] shall be in the range of 0 to 255, inclusive. When not present, the value of **num_overlay_elements_minus1**[*i*] is inferred to be equal to 0.

overlay_element_label_min[*i*][*j*] and **overlay_element_label_max**[*i*][*j*] indicate the minimum and maximum values, respectively, of the range of sample values corresponding to the *j*-th overlay element of the *i*-th overlay. The length of the **overlay_element_label_min**[*i*][*j*] and the **overlay_element_label_max**[*i*][*j*] syntax elements is **overlay_element_label_min_max_length_minus8** + 8 bits.

The variable **overlayElementId**[*i*][*x*][*y*] specifying the overlay element identifier of the *i*-th overlay for the sample location (*x*, *y*) relative to the top-left sample is derived as follows, where **p**[*i*][*x*][*y*] refers to the luma sample at location (*x*, *y*) in the decoded label auxiliary picture of the *i*-th overlay:

```

for( y = 0; y < pic_height_in_luma_samples; y++ )
  for( x = 0; x < pic_width_in_luma_samples; x++ )
    for( i = 0; i <= number_overlays_minus1[ i ] ) {
      overlayElementId[ i ][ x ][ y ] = 0
      for( j = 0; j <= num_overlay_elements_minus1[ i ]; j++ )
        if( p[ i ][ x ][ y ] >= overlay_element_label_min[ i ][ j ] &&
            p[ i ][ x ][ y ] <= overlay_element_label_max[ i ][ j ] )
          overlayElementId[ i ][ x ][ y ] = j
    }

```

(F-96)

overlay_zero_bit shall be equal to 0.

overlay_language[*i*] contains a language tag as specified by RFC 5646 followed by a null termination byte equal to 0x00. The length of the **overlay_language**[*i*] syntax element shall be less than or equal to 255 bytes, not including the null termination byte.

overlay_name[*i*] indicates the name of the *i*-th overlay. The length of the **overlay_name**[*i*] syntax element shall be less than or equal to 255 bytes, not including the null termination byte.

overlay_element_name[*i*][*j*] indicates the name of the *j*-th overlay element of the *i*-th overlay. The length of the **overlay_element_name**[*i*][*j*] syntax element shall be less than or equal to 255 bytes, not including the null termination byte.

overlay_info_persistence_flag specifies the persistence of the overlay information SEI message. **overlay_info_persistence_flag** equal to 0 specifies that the overlay information SEI message applies to the current decoded picture only.

When an access unit contains an auxiliary picture **picA** with **nuh_layer_id** equal to **nuhLayerIdA** and **AuxId**[**nuhLayerIdA**] in the range of 128..159, and **nuhLayerIdA** is equal to any of **overlay_content_layer_id**[*i*], **overlay_label_layer_id**[*i*], **overlay_label_layer_id**[*i*], and **overlay_alpha_layer_id**[*i*], **overlay_info_persistence_flag** equal to 1 specifies that the overlay information SEI message persists for the CLVS containing the auxiliary picture **picA** in output order until one or more of the following conditions are true:

- A new CLVS begins for the layer containing the auxiliary picture **picA**.
- A new CLVS begins for the layer containing the primary picture associated with the auxiliary picture **picA**.
- The bitstream ends.
- A picture **picB** in an access unit containing an overlay information SEI message is output for which **PicOrderCnt**(**picB**) is greater than **PicOrderCnt**(**picA**), where **PicOrderCnt**(**picB**) and **PicOrderCnt**(**picA**) are the **PicOrderCntVal** values of **picB** and **picA**, respectively, immediately after the invocation of the decoding process for picture order count for **picB**.

F.14.3.10 Temporal motion vector prediction constraints SEI message semantics

The temporal motion vector prediction constraints SEI message indicates constraints on collocated pictures for temporal motion vector prediction. This SEI message may be used to determine whether the motion vectors of earlier pictures in decoding order no longer need to be stored and whether the motion vectors of the current picture and subsequent pictures need to be stored.

The temporal motion vector prediction constraints SEI message is a prefix SEI message. The temporal motion vector prediction constraints SEI message may be present in an access unit with TemporalId equal to 0 and shall not be present in an access unit with TemporalId greater than 0.

The following semantics apply separately to each nuh_layer_id targetLayerId among the nuh_layer_id values to which the temporal motion vector prediction constraints SEI message applies. Let associatedLayerIdList consist of each targetLayerId value to which this temporal motion vector prediction constraints SEI message applies.

Let a set of pictures associatedPicSet be the pictures with nuh_layer_id equal to targetLayerId from the access unit containing the SEI message, inclusive, up to but not including the first of any of the following in decoding order:

- The next access unit, in decoding order, that contains a temporal motion vector prediction constraints SEI message with an associatedLayerIdList that contains targetLayerId.
- The first picture of the next CLVS, in decoding order, of the layer with nuh_layer_id equal to targetLayerId.

prev_pics_not_used_flag equal to 1 indicates that the syntax elements for all coded pictures that are within or follow the access unit containing the current picture in decoding order are constrained such that no temporal motion vector from any picture that has nuh_layer_id equal to any value in associatedLayerIdList and precedes the access unit containing the current picture in decoding order is used directly or indirectly in decoding of any coded picture that is within or follows the access unit containing the current picture in decoding order. **prev_pics_not_used_flag** equal to 0 indicates that the bitstream may or may not fulfill the constraints indicated by **prev_pics_not_used_flag** equal to 1.

NOTE 1 When **prev_pics_not_used_flag** is equal to 1, decoders may empty the “motion vector storage” for all reference pictures with nuh_layer_id equal to targetLayerId in the decoded picture buffer.

prev_pics_not_used_flag shall be equal to 1 when both of the following conditions are true:

- **no_intra_layer_col_pic_flag** is equal to 1 in the previous temporal motion vector prediction constraints SEI message applying to nuh_layer_id equal to targetLayerId.
- The previous temporal motion vector prediction constraints SEI message applying to nuh_layer_id equal to targetLayerId and the current temporal motion vector prediction constraints SEI message apply to the same CLVS of the layer with nuh_layer_id equal to targetLayerId.

no_intra_layer_col_pic_flag equal to 1 indicates the following:

- If NumDirectRefLayers[targetLayerId] is equal to 0, slice_temporal_mvp_enabled_flag is not present or is equal to 0 in each picture in associatedPicSet.
- Otherwise, all the pictures in associatedPicSet do not use temporal motion vector prediction or use collocated pictures with nuh_layer_id different from targetLayerId.

When **no_intra_layer_col_pic_flag** is equal to 0, no constraint on the collocated picture of the pictures with nuh_layer_id equal to targetLayerId is indicated.

Let NoIntraLayerColPicFlag[targetLayerId] be equal to **no_intra_layer_col_pic_flag**.

NOTE 2 The motion vectors of the current picture with nuh_layer_id equal to layerId have to be stored when they may be used for temporal motion vector prediction of other pictures in the same layer or when they may be

ISO/IEC 23008-2:2017(E)

used for inter-layer motion prediction. In other words, the motion vectors of the current picture have to be stored when at least one of the following is true:

- `sps_temporal_mvp_enabled_flag` in the active SPS for the current picture is equal to 1 and `NoIntraLayerColPicFlag[layerId]` is equal 0.
- `NoIntraLayerColPicFlag[layerId]` is equal to 1 and there is a `nuh_layer_id` value `nuhLayerIdA` such that `VpsInterLayerMotionPredictionEnabled[LayerIdxInVps[nuhLayerIdA]][LayerIdxInVps[layerId]]` is equal to 1.

NOTE 3 The motion vectors of a picture with `nuh_layer_id` equal to `layerId` need no longer be stored when the picture is marked as “unused for reference”, or the picture is not used for temporal motion vector prediction of other pictures in the same layer and all pictures in the same access unit that may use the picture as a reference for inter-layer motion prediction have been decoded, or the access unit containing the picture precedes the current access unit in decoding order, where this SEI message is present with associatedLayerIdList including the `nuh_layer_id` of the picture and `prev_pics_not_used_flag` equal to 1.

F.14.3.11 Frame-field information SEI message semantics

The frame-field information SEI message may be used to indicate how the associated picture should be displayed, the source scan type of the associated picture, and whether the associated picture is a duplicate of a previous picture, in output order, of the same layer.

The following semantics apply separately to each `nuh_layer_id` `targetLayerId` among the `nuh_layer_id` values to which the frame-field information SEI message applies.

A frame-field information SEI message associated with `nuh_layer_id` equal to `targetLayerId` shall be present in an access unit, when all of the following conditions are true:

- A picture with `nuh_layer_id` equal to `targetLayerId` is present in the access unit.
- `frame_field_info_present_flag` is equal to 1 in the active SPS for the layer with `nuh_layer_id` equal to `targetLayerId`.
- `targetLayerId` is greater than 0 or none of the following conditions is true:
 - A non-nested picture timing SEI message is present in the access unit.
 - A picture timing SEI message directly contained in a scalable nesting SEI message is present in the access unit.

A frame-field information SEI message that applies to a particular set of layers shall not be present when one or more of the following conditions are true:

- The value of `field_seq_flag` is not the same for all active SPSs for the particular set of layers.
- The values of `general_progressive_source_flag` and `general_interlaced_source_flag` are not identical, respectively, for all the `profile_tier_level()` syntax structures that apply to the layers to which the frame-field information SEI message applies.

The semantics of `ffinfo_pic_struct`, `ffinfo_source_scan_type` and `ffinfo_duplicate_flag` apply layer-wise to each value of `targetLayerId`.

ffinfo_pic_struct has the same semantics as the `pic_struct` syntax element in the picture timing SEI message.

ffinfo_source_scan_type has the same semantics as the `source_scan_type` syntax element in the picture timing SEI message.

ffinfo_duplicate_flag has the same semantics as the `duplicate_flag` syntax element in the picture timing SEI message.

F.15 Video usability information

F.15.1 General

The specifications in E.1 apply.

F.15.2 VUI syntax

The specifications in E.2 and its subclauses apply.

F.15.3 VUI semantics

F.15.3.1 VUI parameters semantics

The specifications in E.3.1 apply by replacing the semantics of `field_seg_flag`, `frame_field_info_present_flag` and `vui_timing_info_present_flag` with those below and with the following additions:

- It is a requirement of bitstream conformance that, when `nuh_layer_id` `layerId` is greater than 0 and `NumDirectRefLayers[layerId]` is greater than 0, `video_signal_type_present_flag` present in or inferred for the active SPS for `nuh_layer_id` equal to `layerId` shall be equal to 0.
- When the current picture has `nuh_layer_id` `layerIdCurr` greater than 0, either `NumDirectRefLayers[layerIdCurr]` is greater than 0 or `MultiLayerExtSpsFlag` derived from the active SPS for the `nuh_layer_id` equal to `layerIdCurr` is equal to 1, and the active SPS for `nuh_layer_id` equal to `layerIdCurr` contains the VUI parameters syntax structure, the following apply:
 - The values of `video_format`, `video_full_range_flag`, `colour_primaries`, `transfer_characteristics`, and `matrix_coefs` are inferred to be equal to `video_vps_format`, `video_full_range_vps_flag`, `colour_primaries_vps`, `transfer_characteristics_vps`, and `matrix_coefs_vps`, respectively, of the `vps_video_signal_info_idx[j]`-th `video_signal_info()` syntax structure in the active VPS where `j` is equal to `LayerIdxInVps[layerIdCurr]`.
 - The values of `video_format`, `video_full_range_flag`, `colour_primaries`, `transfer_characteristics`, and `matrix_coefs` signalled in the active SPS for the layer with `nuh_layer_id` equal to `layerIdCurr` are ignored.

NOTE 1 The values are inferred from the VPS when a non-base layer refers to an SPS that is also referred to by the base layer, in which case the SPS has `nuh_layer_id` equal to 0. For the base layer, the values of these parameters in the active SPS for the base layer apply.

`field_seq_flag` equal to 1 indicates that the layers for which the SPS is an active SPS within the CVS convey pictures that represent fields, and specifies the following:

- When the SPS is an active SPS for `nuh_layer_id` equal to 0, a picture timing SEI message that is not nested or that is directly contained in a scalable nesting SEI message and applies to `nuh_layer_id` equal to 0 shall be present in every such access unit of the current CVS that contains a coded picture with `nuh_layer_id` equal to 0.
- When the SPS is an active SPS for the `nuh_layer_id` value `nuhLayerId` greater than 0, a frame-field information SEI message shall be present for `nuh_layer_id` equal to `nuhLayerId` in every access unit containing a picture for the current CLVS of the layer with `nuh_layer_id` equal to `nuhLayerId`.

`field_seq_flag` equal to 0 indicates that the layers for which the SPS is an active SPS within the CVS convey pictures that represent frames and that a picture timing SEI message or a frame-field information SEI message may or may not be present for the pictures within the CVS belonging to any layer for which the SPS is an active SPS. When `field_seq_flag` is not present, it is inferred to be equal to 0.

ISO/IEC 23008-2:2017(E)

When `general_frame_only_constraint_flag` is present in the SPS and is equal to 1, the value of `field_seq_flag` shall be equal to 0. When `general_frame_only_constraint_flag` is present in the active VPS, applies for a layer for which the SPS is an active SPS, and is equal to 1, the value of `field_seq_flag` shall be equal to 0.

NOTE 2 The specified decoding process does not treat access units conveying pictures that represent fields or frames differently. A sequence of pictures that represent fields would therefore be coded with the picture dimensions of an individual field. For example, access units containing pictures that represent 1080i fields would commonly have cropped output dimensions of 1920x540, while the sequence picture rate would commonly express the rate of the source fields (typically between 50 and 60 Hz), instead of the source frame rate (typically between 25 and 30 Hz).

frame_field_info_present_flag equal to 1 specifies that picture timing SEI messages or frame-field information SEI messages are present for every picture for which this SPS is the active SPS and the picture timing SEI messages, when present, include the `pic_struct`, `source_scan_type`, and `duplicate_flag` syntax elements. `frame_field_info_present_flag` equal to 0 specifies that the `pic_struct` syntax element is not present in picture timing SEI messages associated with pictures for which the SPS is the active SPS.

When `frame_field_info_present_flag` is present and either or both of the following conditions are true, `frame_field_info_present_flag` shall be equal to 1:

- `field_seq_flag` is equal to 1.
- `general_progressive_source_flag` and `general_interlaced_source_flag` are present in this SPS, `general_progressive_source_flag` is equal to 1, and `general_interlaced_source_flag` is equal to 1.

When `frame_field_info_present_flag` is not present, its value is inferred as follows:

- If `general_progressive_source_flag` and `general_interlaced_source_flag` are present in this SPS, `general_progressive_source_flag` is equal to 1, and `general_interlaced_source_flag` is equal to 1, `frame_field_info_present_flag` is inferred to be equal to 1.
- Otherwise, `frame_field_info_present_flag` is inferred to be equal to 0.

vui_timing_info_present_flag equal to 1 specifies that `vui_num_units_in_tick`, `vui_time_scale`, `vui_poc_proportional_to_timing_flag`, and `vui_hrd_parameters_present_flag` are present in the `vui_parameters()` syntax structure. `vui_timing_info_present_flag` equal to 0 specifies that `vui_num_units_in_tick`, `vui_time_scale`, `vui_poc_proportional_to_timing_flag`, and `vui_hrd_parameters_present_flag` are not present in the `vui_parameters()` syntax structure. It is a requirement of bitstream conformance that, when `MultiLayerExtSpsFlag` is equal to 1, `vui_timing_info_present_flag` shall be equal to 0.

F.15.3.2 HRD parameters semantics

The specifications in E.3.2 apply with the replacement of each instance of “access unit level” and “sub-picture level” with “partition unit level” and “sub-partition level”, respectively, and with the following additions.

`initial_cpb_removal_delay_length_minus1` plus 1 within the `j`-th `hrd_parameters()` syntax structure in the VPS specifies the length, in bits, of the `nal_initial_arrival_delay[k]` and `vcl_initial_arrival_delay[k]` syntax elements of the bitstream partition initial arrival time SEI message that is contained in a bitstream partition nesting SEI message within a scalable nesting SEI message with values of `MaxTemporalId[0]`, `sei_ols_idx`, `sei_partitioning_scheme_idx`, and `bsp_idx` such that `bsp_hrd_idx[sei_ols_idx][sei_partitioning_scheme_idx][MaxTemporalId[0]][k][bsp_idx]` is equal to `j`. When the `initial_cpb_removal_delay_length_minus1` syntax element is not present, it is inferred to be equal to 23.

It is a requirement of bitstream conformance that the value of `sub_pic_hrd_params_present_flag` shall be the same for all `hrd_parameters()` syntax structures that apply to at least one bitstream partition of a particular output layer set.

F.15.3.3 Sub-layer HRD parameters semantics

The specifications in E.3.3 apply.

STANDARDSISO.COM : Click to view the full PDF of ISO/IEC 23008-2:2017

Annex G
(normative)

Multiview high efficiency video coding

G.1 General

This annex specifies syntax, semantics, and decoding processes for multiview high efficiency video coding that use the syntax, semantics, and decoding processes specified in Clauses 2 to 10 and Annexes A to F. This annex also specifies profiles, tiers, and levels for multiview high efficiency video coding.

G.2 References

The list of normative references in F.2 applies.

G.3 Terms and definitions

The specifications in F.3 and its subclauses apply.

G.4 Abbreviations

The specifications in F.4 apply.

G.5 Conventions

The specifications in F.5 apply.

G.6 Bitstream and picture formats, partitionings, scanning processes, and neighbouring relationships

The specifications in F.6 apply.

G.7 Syntax and semantics

The specifications in F.7 and its subclauses apply.

G.8 Decoding processes

G.8.1 General decoding process

G.8.1.1 General

The specifications of F.8.1.1 apply.

G.8.1.2 Decoding process for a coded picture with nuh_layer_id greater than 0

The decoding process for the current picture CurrPic is as follows:

1. The decoding of NAL units is specified in G.8.2.
2. The processes in G.8.1.3 and F.8.3.4 specify the following decoding processes using syntax elements in the slice segment layer and above:

- Prior to decoding the first slice of the current picture, G.8.1.3 is invoked.
 - At the beginning of the decoding process for each P or B slice, the decoding process for reference picture lists construction specified in F.8.3.4 is invoked for derivation of reference picture list 0 (RefPicList0), and when decoding a B slice, reference picture list 1 (RefPicList1).
3. The processes in G.8.4, G.8.5, G.8.6, and G.8.7 specify decoding processes using syntax elements in all syntax structure layers. It is a requirement of bitstream conformance that the coded slices of the picture shall contain slice segment data for every coding tree unit of the picture, such that the division of the picture into slices, the division of the slices into slice segments, and the division of the slice segments into coding tree units each form a partitioning of the picture.

G.8.1.3 Decoding process for inter-layer reference picture set

Outputs of this process are updated lists of inter-layer reference pictures RefPicSetInterLayer0 and RefPicSetInterLayer1 and the variables NumActiveRefLayerPics0 and NumActiveRefLayerPics1.

The variable currLayerId is set equal to nuh_layer_id of the current picture.

The lists RefPicSetInterLayer0 and RefPicSetInterLayer1 are first emptied, NumActiveRefLayerPics0 and NumActiveRefLayerPics1 are set equal to 0 and the following applies:

```

for( i = 0; i < NumActiveRefLayerPics; i++ ) {
    refPicSet0Flag =
        ( ( ViewId[ currLayerId ] <= ViewId[ 0 ] && ViewId[ currLayerId ] <= ViewId[ RefPicLayerId[ i ] ] ) ||
          ( ViewId[ currLayerId ] >= ViewId[ 0 ] && ViewId[ currLayerId ] >= ViewId[ RefPicLayerId[ i ] ] ) )
    if( there is a picture picX in the DPB that is in the same access unit as the current picture and has
        nuh_layer_id equal to RefPicLayerId[ i ] ) {
        if( refPicSet0Flag ) {
            RefPicSetInterLayer0[ NumActiveRefLayerPics0 ] = picX
            RefPicSetInterLayer0[ NumActiveRefLayerPics0++ ] is marked as "used for long-term
reference"
        } else {
            RefPicSetInterLayer1[ NumActiveRefLayerPics1 ] = picX
            RefPicSetInterLayer1[ NumActiveRefLayerPics1++ ] is marked as "used for long-term
reference"
        }
    } else {
        if( refPicSet0Flag )
            RefPicSetInterLayer0[ NumActiveRefLayerPics0++ ] = "no reference picture"      (G-1)
        else
            RefPicSetInterLayer1[ NumActiveRefLayerPics1++ ] = "no reference picture"
    }
}

```

There shall be no entry equal to "no reference picture" in RefPicSetInterLayer0 or RefPicSetInterLayer1.

There shall be no picture that has discardable_flag equal to 1 in RefPicSetInterLayer0 or RefPicSetInterLayer1.

If the current picture is a RADL picture, there shall be no entry in RefPicSetInterLayer0 or RefPicSetInterLayer1 that is a RASL picture.

NOTE An access unit may contain both RASL and RADL pictures.

ISO/IEC 23008-2:2017(E)

G.8.2 NAL unit decoding process

The specifications in F.8.2 apply.

G.8.3 Slice decoding processes

The specifications in F.8.3 and its subclauses apply.

G.8.4 Decoding process for coding units coded in intra prediction mode

The specifications in F.8.4 apply.

G.8.5 Decoding process for coding units coded in inter prediction mode

The specifications in F.8.5 apply.

G.8.6 Scaling, transformation and array construction process prior to deblocking filter process

The specifications in F.8.6 apply.

G.8.7 In-loop filter process

The specifications in F.8.7 apply.

G.9 Parsing process

The specifications in F.9 apply.

G.10 Specification of bitstream subsets

The specifications in F.10 and its subclauses apply.

G.11 Profiles, tiers, and levels

G.11.1 Profiles

G.11.1.1 Multiview Main profile

For a layer in an output operation point associated with an OLS in a bitstream, the layer being conforming to the Multiview Main profile, the following applies:

- Let `olsIdx` be the OLS index of the OLS, the sub-bitstream `subBitstream` and the base layer sub-bitstream `baseBitstream` are derived as specified in F.11.3.

When `vps_base_layer_internal_flag` is equal to 1, the base layer sub-bitstream `baseBitstream` shall obey the following constraints:

- The base layer sub-bitstream `baseBitstream` shall be indicated to conform to the Main profile.

The sub-bitstream `subBitstream` shall obey the following constraints:

- All active VPSs shall have `vps_num_rep_formats_minus1` in the range of 0 to 15, inclusive.
- All active SPSs for layers in `subBitstream` shall have `chroma_format_idc` equal to 1 only.
- All active SPSs for layers in `subBitstream` shall have `transform_skip_rotation_enabled_flag`, `transform_skip_context_enabled_flag`, `implicit_rdp_pcm_enabled_flag`, `explicit_rdp_pcm_enabled_flag`, `extended_precision_processing_flag`, `intra_smoothing_disabled_flag`, `high_precision_offsets_enabled_flag`, `persistent_rice_adaptation_enabled_flag`, and `cabac_bypass_alignment_enabled_flag`, when present, equal to 0 only.

- CtbLog2SizeY derived from all active SPSs for layers in subBitstream shall be in the range of 4 to 6, inclusive.
- All active PPSs for layers in subBitstream shall have log2_max_transform_skip_block_size_minus2 and chroma_qp_offset_list_enabled_flag, when present, equal to 0 only.
- ScalabilityId[j][smIdx] derived according to any active VPS shall be equal to 0 for any smIdx value not equal to 1 or 3 and for any value of j such that layer_id_in_nuh[j] is among layerIdListTarget that was used to derive subBitstream.
- When NumLayersInIdList[OlsIdxToLsIdx[olsIdx]] is equal to 2, output_layer_flag[olsIdx][j] derived according to any active VPS shall be equal to 1 for j in the range of 0 to 1, inclusive, for subBitstream.
- All active VPSs shall have alt_output_layer_flag[olsIdx] equal to 0 only.
- When ViewOrderIdx[i] derived according to any active VPS is equal to 1 for the layer with nuh_layer_id equal to i in subBitstream, inter_view_mv_vert_constraint_flag shall be equal to 1 in the sps_multilayer_extension() syntax structure in each active SPS for that layer.
- When ViewOrderIdx[i] derived according to any active VPS is greater than 0 for the layer with nuh_layer_id equal to i in subBitstream, num_ref_loc_offsets shall be equal to 0 in each active PPS for that layer.
- When ViewOrderIdx[i] derived according to any active VPS is greater than 0 for the layer with nuh_layer_id equal to i in subBitstream, the values of pic_width_in_luma_samples and pic_height_in_luma_samples in each active SPS for that layer shall be equal to the values of pic_width_in_luma_samples and pic_height_in_luma_samples, respectively, in each active SPS for all reference layers of that layer.
- For a layer with nuh_layer_id iNuhLid equal to any value included in layerIdListTarget that was used to derive subBitstream, the value of NumRefLayers[iNuhLid], which specifies the total number of direct and indirect reference layers and is derived as specified in F.7.4.3.1, shall be less than or equal to 4.
- All active SPSs for layers in subBitstream shall have sps_range_extension_flag and sps_scc_extension_flag equal to 0 only.
- All active PPSs for layers in subBitstream shall have pps_range_extension_flag and pps_scc_extension_flag equal to 0 only.
- All active SPSs for layers in subBitstream shall have bit_depth_luma_minus8 equal to 0 only.
- All active SPSs for layers in subBitstream shall have bit_depth_chroma_minus8 equal to 0 only.
- All active PPSs for layers in subBitstream shall have colour_mapping_enabled_flag equal to 0 only.
- When an active PPS for any layer in subBitstream has tiles_enabled_flag equal to 1, it shall have entropy_coding_sync_enabled_flag equal to 0.
- When an active PPS for any layer in subBitstream has tiles_enabled_flag equal to 1, ColumnWidthInLumaSamples[i] shall be greater than or equal to 256 for all values of i in the range of 0 to num_tile_columns_minus1, inclusive, and RowHeightInLumaSamples[j] shall be greater than or equal to 64 for all values of j in the range of 0 to num_tile_rows_minus1, inclusive.

ISO/IEC 23008-2:2017(E)

- The number of times `read_bits(1)` is called in 9.3.4.3.3 and 9.3.4.3.4 when parsing `coding_tree_unit()` data for any coding tree unit shall be less than or equal to $5 * \text{RawCtuBits} / 3$.
- `general_level_idc` and `sub_layer_level_idc[i]` for all values of `i` in active SPSs for any layer in `subBitstream` shall not be equal to 255 (which indicates level 8.5).
- The level constraints specified for the Multiview Main profile in G.11.2 shall be fulfilled.
- For any active VPS, `ViewOrderIdx[i]` shall be greater than `ViewOrderIdx[j]` for any values of `i` and `j` among `layerIdListTarget` that was used to derive `subBitstream` such that `AuxId[i]` is equal to `AuxId[j]` and `i` is greater than `j`.

In the remainder of this subclause and G.11.2.1, all syntax elements in the `profile_tier_level()` syntax structure refer to those in the `profile_tier_level()` syntax structure associated with the layer.

Conformance of a layer in an output operation point associated with an OLS in a bitstream to the Multiview Main profile is indicated as follows:

- If `OpTid` of the output operation point is equal to `vps_max_sub_layer_minus1`, the conformance is indicated by `general_profile_idc` being equal to 6 or `general_profile_compatibility_flag[6]` being equal to 1, and `general_max_12bit_constraint_flag` being equal to 1, `general_max_10bit_constraint_flag` being equal to 1, `general_max_8bit_constraint_flag` being equal to 1, `general_max_422chroma_constraint_flag` being equal to 1, `general_max_420chroma_constraint_flag` being equal to 1, `general_max_monochrome_constraint_flag` being equal to 0, `general_intra_constraint_flag` being equal to 0, and `general_one_picture_only_constraint_flag` being equal to 0, and `general_lower_bit_rate_constraint_flag` being equal to 1.
- Otherwise (`OpTid` of the output operation point is less than `vps_max_sub_layer_minus1`), the conformance is indicated by `sub_layer_profile_idc[OpTid]` being equal to 6 or `sub_layer_profile_compatibility_flag[OpTid][6]` being equal to 1, and `sub_layer_max_12bit_constraint_flag[OpTid]` being equal to 1, `sub_layer_max_10bit_constraint_flag[OpTid]` being equal to 1, `sub_layer_max_8bit_constraint_flag[OpTid]` being equal to 1, `sub_layer_max_422chroma_constraint_flag[OpTid]` being equal to 1, `sub_layer_max_420chroma_constraint_flag[OpTid]` being equal to 1, `sub_layer_max_monochrome_constraint_flag[OpTid]` being equal to 0, `sub_layer_intra_constraint_flag[OpTid]` being equal to 0, and `sub_layer_one_picture_only_constraint_flag[OpTid]` being equal to 0, and `sub_layer_lower_bit_rate_constraint_flag[OpTid]` being equal to 1.

G.11.2 Tiers and levels

G.11.2.1 General tier and level limits

For purposes of comparison of tier capabilities, the tier with `general_tier_flag` or `sub_layer_tier_flag[i]` equal to 0 is considered to be a lower tier than the tier with `general_tier_flag` or `sub_layer_tier_flag[i]` equal to 1.

For purposes of comparison of level capabilities, a particular level of a specific tier is considered to be a lower level than some other level of the same tier when the value of the `general_level_idc` or `sub_layer_level_idc[i]` of the particular level is less than that of the other level.

The following is specified for expressing the constraints in this subclause and G.11.2.2:

- The value of each of the variables `CpbVclFactor`, `CpbNalFactor`, `FormatCapabilityFactor`, and `MinCrScaleFactor` is the same as that specified in Table A.8 for the Main profile.

- Let access unit n be the n -th access unit in decoding order, with the first access unit being access unit 0 (i.e. the 0-th access unit).
- Let the variable fR be set equal to $1 \div 300$.
- Let the variable $olsIdx$ be the index of the OLS.
- For each layer with nuh_layer_id equal to $currLayerId$, let the variable $layerSizeInSamplesY$ be derived as follows:

$$layerSizeInSamplesY = pic_width_vps_in_luma_samples * pic_height_vps_in_luma_samples \quad (G-2)$$

where $pic_width_vps_in_luma_samples$ and $pic_height_vps_in_luma_samples$ are found in the $vps_rep_format_idx[LayerIdxInVps[currLayerId]]$ -th $rep_format()$ syntax structure in the VPS.

Each layer with nuh_layer_id equal to $currLayerId$ conforming to a profile at a specified tier and level shall obey the following constraints for each bitstream conformance test as specified in F.13, where “access unit” is used to denote the picture unit in the layer and the CPB is understood to be the BPB:

- a) The value of $layerSizeInSamplesY$ shall be less than or equal to $MaxLumaPs$, where $MaxLumaPs$ is specified in Table A.6 for the tier and level of the layer.
- b) The value of $pic_width_vps_in_luma_samples$ of the $vps_rep_format_idx[LayerIdxInVps[currLayerId]]$ -th $rep_format()$ syntax structure in the VPS shall be less than or equal to $\text{Sqrt}(MaxLumaPs * 8)$.
- c) The value of $pic_height_vps_in_luma_samples$ of the $vps_rep_format_idx[LayerIdxInVps[currLayerId]]$ -th $rep_format()$ syntax structure in the VPS shall be less than or equal to $\text{Sqrt}(MaxLumaPs * 8)$.
- d) The value of $max_vps_dec_pic_buffering_minus1[olsIdx][LayerIdxInVps[currLayerId]][HighestTid]$ shall be less than or equal to $MaxDpbSize$ as derived by Formula (A-2), with $PicSizeInSamplesY$ being replaced with $layerSizeInSamplesY$, for the tier and level of the layer.
- e) For level 5 and higher levels, the value of $CtbSizeY$ for the layer shall be equal to 32 or 64.
- f) The value of $NumPicTotalCurr$ for each picture in the layer shall be less than or equal to 8.
- g) When decoding each coded picture in the layer, the value of $num_tile_columns_minus1$ shall be less than $MaxTileCols$ and $num_tile_rows_minus1$ shall be less than $MaxTileRows$, where $MaxTileCols$ and $MaxTileRows$ are specified in Table A.6 for the tier and level of the layer.
- h) For the VCL HRD parameters of the layer, $CpbSize[i]$ shall be less than or equal to $CpbVclFactor * MaxCPB$ for at least one of the delivery schedules identified by $bsp_sched_idx[olsIdx][0][HighestTid][combIdx][LayerIdxInVps[currLayerId]]$ for $combIdx$ ranging from 0 to $num_bsp_schedules_minus1[olsIdx][0][HighestTid]$, inclusive, where $CpbSize[i]$ is specified in F.13.1 and $MaxCPB$ is specified in Table A.6 for the tier and level of the layer in units of $CpbVclFactor$ bits.
- i) For the NAL HRD parameters of the layer, $CpbSize[i]$ shall be less than or equal to $CpbNalFactor * MaxCPB$ for at least one of the delivery schedules identified by $bsp_sched_idx[olsIdx][0][HighestTid][combIdx][LayerIdxInVps[currLayerId]]$ for $combIdx$ ranging from 0 to $num_bsp_schedules_minus1[olsIdx][0][HighestTid]$, inclusive, where $CpbSize[i]$ is specified in F.13.1 and $MaxCPB$ is specified in Table A.6 for the tier and level of the layer in units of $CpbNalFactor$ bits.

ISO/IEC 23008-2:2017(E)

Table A.6 specifies the limits for each level of each tier for levels other than level 8.5.

A tier and level to which a layer in an output operation point associated with an OLS in a bitstream conforms are indicated by the syntax elements `general_tier_flag` and `general_level_idc` if `OpTid` of the output layer set is equal to `vps_max_sub_layer_minus1`, and by the syntax elements `sub_layer_tier_flag[OpTid]` and `sub_layer_level_idc[OpTid]` otherwise, as follows:

- If the specified level is not level 8.5, `general_tier_flag` or `sub_layer_tier_flag[OpTid]` equal to 0 indicates conformance to the Main tier, and `general_tier_flag` or `sub_layer_tier_flag[OpTid]` equal to 1 indicates conformance to the High tier, according to the tier constraints specified in Table A.6, and `general_tier_flag` and `sub_layer_tier_flag[OpTid]` shall be equal to 0 for levels below level 4 (corresponding to the entries in Table A.6 marked with "-"). Otherwise (the specified level is level 8.5), it is a requirement of bitstream conformance that `general_tier_flag` and `sub_layer_tier_flag[OpTid]` shall be equal to 1 and the value 0 for `general_tier_flag` and `sub_layer_tier_flag[OpTid]` is reserved for future use by ITU-T | ISO/IEC, and decoders shall ignore the value of `general_tier_flag` and `sub_layer_tier_flag[OpTid]`.
- `general_level_idc` and `sub_layer_level_idc[OpTid]` shall be set equal to a value of 30 times the level number specified in Table A.6.

G.11.2.2 Profile-specific tier and level limits for the Multiview Main profile

The following is specified for expressing the constraints in this subclause:

- The variable `HbrFactor` is set equal to 1.
- The variable `BrVclFactor` is set equal to `CpbVclFactor * HbrFactor`.
- The variable `BrNalFactor` is set equal to `CpbNalFactor * HbrFactor`.
- The variable `MinCr` is set equal to $\text{MinCrBase} * \text{MinCrScaleFactor} \div \text{HbrFactor}$, where `MinCrBase` is specified in Table A.7.

Each layer conforming to the Multiview Main profile at a specified tier and level shall obey the following constraints for each conformance test as specified in F.13, where "access unit" is used to denote the picture unit in the layer, and the CPB is understood to be the BPB:

- a) The nominal removal time of access unit n (with n greater than 0) from the CPB, as specified in F.13.2.3, shall satisfy the constraint that $\text{AuNominalRemovalTime}[n] - \text{AuCpbRemovalTime}[n - 1]$ is greater than or equal to $\text{Max}(\text{layerSizeInSamplesY} \div \text{MaxLumaSr}, \text{fR})$, where `layerSizeInSamplesY` is the value of `layerSizeInSamplesY` for access unit $n - 1$ and `MaxLumaSr` is the value specified in Table A.7 that applies to access unit $n - 1$ for the tier and level of the layer.
- b) The difference between consecutive output times of pictures in different access units, as specified in F.13.3.3, shall satisfy the constraint that `DpbOutputInterval[n]` is greater than or equal to $\text{Max}(\text{layerSizeInSamplesY} \div \text{MaxLumaSr}, \text{fR})$, where `layerSizeInSamplesY` is the value of `layerSizeInSamplesY` of access unit n and `MaxLumaSr` is the value specified in Table A.7 for access unit n for the tier and level of the layer, provided that access unit n is an access unit that has a picture that is output and is not the last of such access units.
- c) The removal time of access unit 0 shall satisfy the constraint that the number of coded slice segments in access unit 0 is less than or equal to $\text{Min}(\text{Max}(1, \text{MaxSliceSegmentsPerPicture} * \text{MaxLumaSr} / \text{MaxLumaPs} * (\text{AuCpbRemovalTime}[0] - \text{AuNominalRemovalTime}[0]) + \text{MaxSliceSegmentsPerPicture} * \text{layerSizeInSamplesY} / \text{MaxLumaPs}), \text{MaxSliceSegmentsPerPicture})$, for the value of `layerSizeInSamplesY` of access unit 0, where `MaxSliceSegmentsPerPicture`, `MaxLumaPs`, and `MaxLumaSr` are the values specified in Table A.6 and Table A.7 for the tier and level of the layer.

- d) The difference between consecutive CPB removal times of access units n and $n - 1$ (with n greater than 0) shall satisfy the constraint that the number of slice segments in access unit n is less than or equal to $\text{Min}(\text{Max}(1, \text{MaxSliceSegmentsPerPicture} * \text{MaxLumaSr} / \text{MaxLumaPs} * (\text{AuCpbRemovalTime}[n] - \text{AuCpbRemovalTime}[n - 1])), \text{MaxSliceSegmentsPerPicture})$, where $\text{MaxSliceSegmentsPerPicture}$, MaxLumaPs , and MaxLumaSr are the values specified in Table A.6 and Table A.7 that apply to access unit n for the tier and level of the layer.
- e) For the VCL HRD parameters for the layer, $\text{BitRate}[i]$ shall be less than or equal to $\text{BrVclFactor} * \text{MaxBR}$ for at least one of the delivery schedules identified by $\text{bsp_sched_idx}[\text{olsIdx}][0][\text{HighestTid}][\text{combIdx}][\text{LayerIdxInVps}[\text{currLayerId}]]$ for combIdx ranging from 0 to $\text{num_bsp_schedules_minus1}[\text{olsIdx}][0][\text{HighestTid}]$, inclusive, where $\text{BitRate}[i]$ is specified in F.13.1 and MaxBR is specified in Table A.7 in units of BrVclFactor bits/s for the tier and level of the layer.
- f) For the NAL HRD parameters for the layer, $\text{BitRate}[i]$ shall be less than or equal to $\text{BrNalFactor} * \text{MaxBR}$ for at least one of the delivery schedules identified by $\text{bsp_sched_idx}[\text{olsIdx}][0][\text{HighestTid}][\text{combIdx}][\text{LayerIdxInVps}[\text{currLayerId}]]$ for combIdx ranging from 0 to $\text{num_bsp_schedules_minus1}[\text{olsIdx}][0][\text{HighestTid}]$, inclusive, where $\text{BitRate}[i]$ is specified in F.13.1 and MaxBR is specified in Table A.7 in units of BrNalFactor bits/s for the tier and level of the layer.
- g) The sum of the NumBytesInNalUnit variables for access unit 0 shall be less than or equal to $\text{FormatCapabilityFactor} * (\text{Max}(\text{layerSizeInSamplesY}, \text{fR} * \text{MaxLumaSr}) + \text{MaxLumaSr} * (\text{AuCpbRemovalTime}[0] - \text{AuNominalRemovalTime}[0])) \div \text{MinCr}$ for the value of $\text{layerSizeInSamplesY}$ of access unit 0, where MaxLumaSr is specified in Table A.7, and both MaxLumaSr and $\text{FormatCapabilityFactor}$ are the values that apply to access unit 0 for the tier and level of the layer.
- h) The sum of the NumBytesInNalUnit variables for access unit n (with n greater than 0) shall be less than or equal to $\text{FormatCapabilityFactor} * \text{MaxLumaSr} * (\text{AuCpbRemovalTime}[n] - \text{AuCpbRemovalTime}[n - 1]) \div \text{MinCr}$, where MaxLumaSr is specified in Table A.7, and both MaxLumaSr and $\text{FormatCapabilityFactor}$ are the values that apply to access unit n for the tier and level of the layer.
- i) The removal time of access unit 0 shall satisfy the constraint that the number of tiles in coded pictures in access unit 0 is less than or equal to $\text{Min}(\text{Max}(1, \text{MaxTileCols} * \text{MaxTileRows} * 120 * (\text{AuCpbRemovalTime}[0] - \text{AuNominalRemovalTime}[0]) + \text{MaxTileCols} * \text{MaxTileRows} * \text{PicSizeInSamplesY} / \text{MaxLumaPs}), \text{MaxTileCols} * \text{MaxTileRows})$, for the value of $\text{layerSizeInSamplesY}$ of access unit 0, where MaxTileCols and MaxTileRows are the values specified in Table A.6 that apply to access unit 0 for the tier and level of the layer.
- j) The difference between consecutive CPB removal times of access units n and $n - 1$ (with n greater than 0) shall satisfy the constraint that the number of tiles in coded pictures in access unit n is less than or equal to $\text{Min}(\text{Max}(1, \text{MaxTileCols} * \text{MaxTileRows} * 120 * (\text{AuCpbRemovalTime}[n] - \text{AuCpbRemovalTime}[n - 1])), \text{MaxTileCols} * \text{MaxTileRows})$, where MaxTileCols and MaxTileRows are the values specified in Table A.6 that apply to access unit n for the tier and level of the layer.

G.11.3 Decoder capabilities

When a decoder conforms to any profile specified in Annex G, it shall also have the INBLD capability specified in F.11.1.

F.11.2 specifies requirements for a decoder conforming to any profile specified in Annex G.

G.12 Byte stream format

The specifications in F.12 apply.

G.13 Hypothetical reference decoder

The specifications in F.13 and its subclauses apply.

G.14 Supplemental enhancement information

G.14.1 General

The specifications in F.14.1 apply.

G.14.2 SEI payload syntax

G.14.2.1 General SEI payload syntax

The specifications in F.14.2.1 apply.

G.14.2.2 Annex D and Annex F SEI message syntax for multiview high efficiency video coding

The specifications in F.14.2.2 through F.14.2.11 apply.

G.14.2.3 3D reference displays information SEI message syntax

	Descriptor
three_dimensional_reference_displays_info(payloadSize) {	
prec_ref_display_width	ue(v)
ref_viewing_distance_flag	u(1)
if(ref_viewing_distance_flag)	
prec_ref_viewing_dist	ue(v)
num_ref_displays_minus1	ue(v)
for(i = 0; i <= num_ref_displays_minus1; i++) {	
left_view_id[i]	ue(v)
right_view_id[i]	ue(v)
exponent_ref_display_width[i]	u(6)
mantissa_ref_display_width[i]	u(v)
if(ref_viewing_distance_flag) {	
exponent_ref_viewing_distance[i]	u(6)
mantissa_ref_viewing_distance[i]	u(v)
}	
additional_shift_present_flag[i]	u(1)
if(additional_shift_present_flag[i])	
num_sample_shift_plus512[i]	u(10)
}	
three_dimensional_reference_displays_extension_flag	u(1)
}	

G.14.2.4 Depth representation information SEI message syntax

G.14.2.4.1 General

	Descriptor
depth_representation_info(payloadSize) {	
z_near_flag	u(1)
z_far_flag	u(1)
d_min_flag	u(1)
d_max_flag	u(1)
depth_representation_type	ue(v)
if(d_min_flag d_max_flag)	
disparity_ref_view_id	ue(v)
if(z_near_flag)	
depth_rep_info_element(ZNearSign, ZNearExp, ZNearMantissa, ZNearManLen)	
if(z_far_flag)	
depth_rep_info_element(ZFarSign, ZFarExp, ZFarMantissa, ZFarManLen)	
if(d_min_flag)	
depth_rep_info_element(DMinSign, DMinExp, DMinMantissa, DMinManLen)	
if(d_max_flag)	
depth_rep_info_element(DMaxSign, DMaxExp, DMaxMantissa, DMaxManLen)	
if(depth_representation_type == 3) {	
depth_nonlinear_representation_num_minus1	ue(v)
for(i = 1; i <= depth_nonlinear_representation_num_minus1 + 1; i++)	
depth_nonlinear_representation_model[i]	
}	
}	

G.14.2.4.2 Depth representation information element syntax

	Descriptor
depth_rep_info_element(OutSign, OutExp, OutMantissa, OutManLen) {	
da_sign_flag	u(1)
da_exponent	u(7)
da_mantissa_len_minus1	u(5)
da_mantissa	u(v)
}	

G.14.2.5 Multiview scene information SEI message syntax

	Descriptor
multiview_scene_info(payloadSize) {	
min_disparity	se(v)
max_disparity_range	ue(v)
}	

G.14.2.6 Multiview acquisition information SEI message syntax

	Descriptor
<code>multiview_acquisition_info(payloadSize) {</code>	
intrinsic_param_flag	u(1)
extrinsic_param_flag	u(1)
if(intrinsic_param_flag) {	
intrinsic_params_equal_flag	u(1)
prec_focal_length	ue(v)
prec_principal_point	ue(v)
prec_skew_factor	ue(v)
for(i = 0; i <= intrinsic_params_equal_flag ? 0 : numViewsMinus1; i++) {	
sign_focal_length_x[i]	u(1)
exponent_focal_length_x[i]	u(6)
mantissa_focal_length_x[i]	u(v)
sign_focal_length_y[i]	u(1)
exponent_focal_length_y[i]	u(6)
mantissa_focal_length_y[i]	u(v)
sign_principal_point_x[i]	u(1)
exponent_principal_point_x[i]	u(6)
mantissa_principal_point_x[i]	u(v)
sign_principal_point_y[i]	u(1)
exponent_principal_point_y[i]	u(6)
mantissa_principal_point_y[i]	u(v)
sign_skew_factor[i]	u(1)
exponent_skew_factor[i]	u(6)
mantissa_skew_factor[i]	u(v)
}	
}	
if(extrinsic_param_flag) {	
prec_rotation_param	ue(v)
prec_translation_param	ue(v)
for(i = 0; i <= numViewsMinus1; i++)	
for(j = 0; j < 3; j++) { /* row */	
for(k = 0; k < 3; k++) { /* column */	
sign_r[i][j][k]	u(1)
exponent_r[i][j][k]	u(6)
mantissa_r[i][j][k]	u(v)
}	
sign_t[i][j]	u(1)

exponent_t [i][j]	u(6)
mantissa_t [i][j]	u(v)
}	
}	
}	

G.14.2.7 Multiview view position SEI message syntax

multiview_view_position(payloadSize) {	Descriptor
num_views_minus1	ue(v)
for(i = 0; i <= num_views_minus1; i++)	
view_position [i]	ue(v)
}	

G.14.3 SEI payload semantics

G.14.3.1 General SEI payload semantics

The specifications in F.14.3.1 apply with the following modifications and additions.

The list VclAssociatedSeiList is set to consist of payloadType values 2, 3, 6, 9, 15, 16, 17, 19, 22, 23, 45, 47, 56, 128, 131, 132, 134 to 148, inclusive, 161, 165, 167, 168, 177, 178, and 179.

The list PicUnitRepConSeiList is set to consist of payloadType values 0, 1, 2, 6, 9, 15, 16, 17, 19, 22, 23, 45, 47, 56, 128, 129, 131, 132, 133, 135 to 148, inclusive, 160 to 168, inclusive, and 176 to 180, inclusive.

The semantics and persistence scope for each SEI message specified in this annex are specified in the semantics specification for each particular SEI message in the subclauses of this clause.

NOTE Persistence information for SEI messages specified in this annex is informatively summarized in Table G.1.

Table G.1 — Persistence scope of SEI messages (informative)

SEI message	Persistence scope
3D reference displays information	Specified by the semantics of the SEI message
Depth representation information	Specified by the semantics of the SEI message.
Multiview scene information	The CVS containing the SEI message
Multiview acquisition information	The CVS containing the SEI message
Multiview view position SEI message	The CVS containing the SEI message

G.14.3.2 Annex D and Annex F SEI message semantics for multiview high efficiency video coding

G.14.3.2.1 General

The specifications of F.14.3.2 and its subclauses apply with the modifications specified in G.14.3.2.2.

G.14.3.2.2 Scalable nesting SEI message semantics for multiview high efficiency video coding

The specifications of F.14.3.2.7 apply with the following additions.

An SEI message that has payloadType equal to 176 (3D reference displays information) or 180 (multiview view position) shall not be directly contained in a scalable nesting SEI message.

When the scalable nesting SEI message contains an SEI message that has payloadType equal to 177, 178, or 179, bitstream_subset_flag shall be equal to 0.

G.14.3.3 3D reference displays information SEI message semantics

A 3D reference displays information SEI message contains information about the reference display width(s) and reference viewing distance(s) as well as information about the corresponding reference stereo pair(s), i.e. the pair(s) of views to be displayed for the viewer's left and right eyes on the reference display at the reference viewing distance. This information enables a view renderer to generate a proper stereo pair for the target screen width and the viewing distance. The reference display width and viewing distance values are signalled in units of centimetres. The reference pair of view specified in this SEI message can be used to extract or infer parameters related to the distance between the camera centers in the reference stereo pair, which can be used for generation of views for the target display. For multi-view displays, the reference stereo pair corresponds to a pair of views that can be simultaneously observed by the viewer's left and right eyes.

When present, this SEI message shall be associated with an IRAP access unit or with a non-IRAP access unit, when all access units that follow this access unit in the decoding order also follow it in output order. The 3D reference display information SEI message applies to the current access unit and all the access units which follow this access unit in both the output and decoding order until but not including the next IRAP access unit or the next access unit containing a 3D reference displays information SEI message.

NOTE 1 The 3D reference displays information SEI message specifies display parameters for which the 3D sequence was optimized and the corresponding reference parameters. Each reference display (i.e. a reference display width and possibly a corresponding viewing distance) is associated with one reference pair of views by signalling their ViewId. The difference between the values of ViewId is referred to as the baseline distance (i.e. the distance between the centers of the cameras used to obtain the video sequence).

The following formulae can be used for determining the baseline distance and horizontal shift for the receiver's display when the ratio between the receiver's viewing distance and the reference viewing distance is the same as the ratio between the receiver screen width and the reference screen width:

$$\text{baseline}[i] = \text{refBaseline}[i] * (\text{refDisplayWidth}[i] \div \text{displayWidth}) \tag{G-3}$$

$$\text{shift}[i] = \text{refShift}[i] * (\text{refDisplayWidth}[i] \div \text{displayWidth}) \tag{G-4}$$

where refBaseline[i] is equal to right_view_id[i] – left_view_id[i] signalled in this SEI message. Other parameters related to the view generation may be obtained determined by using a similar equation.

$$\text{parameter}[i] = \text{refParameter}[i] * (\text{refDisplayWidth}[i] \div \text{displayWidth}) \tag{G-5}$$

where refParameter[i] is a parameter related to view generation that corresponds to the reference pair of views signalled by left_view_id[i] and right_view_id[i]. In the above formulae, the width of the visible part of the display used for showing the video sequence should be understood under “display width”. The same formulae can also be used for determining the pair of views and horizontal shift or other view synthesis parameters when the viewing distance is not scaled proportionally to the screen width compared to the reference display parameters. In this case, the effect of applying the above equations would be to keep the perceived depth in the same proportion to the viewing distance as in the reference setup.

When the view synthesis related parameters that correspond to the reference stereo pair change from one access unit to another, they should be scaled with the same scaling factor as the parameters in the access unit that the SEI message is associated with. Therefore, the above formula should also be applied to obtain the parameters for a following access unit, where the refParameter is the parameter related to the reference stereo pair associated the following access unit.

The horizontal shift for the receiver's display should also be modified by scaling it with the same factor as that used to scale the baseline distance (or other view synthesis parameters).

prec_ref_display_width specifies the exponent of the maximum allowable truncation error for `refDisplayWidth[i]` as given by $2^{-\text{prec_ref_display_width}}$. The value of `prec_ref_display_width` shall be in the range of 0 to 31, inclusive.

ref_viewing_distance_flag equal to 1 indicates the presence of reference viewing distance. `ref_viewing_distance_flag` equal to 0 indicates that the reference viewing distance is not present.

prec_ref_viewing_dist specifies the exponent of the maximum allowable truncation error for `refViewingDist[i]` as given by $2^{-\text{prec_ref_viewing_dist}}$. The value of `prec_ref_viewing_dist` shall be in the range of 0 to 31, inclusive.

num_ref_displays_minus1 plus 1 specifies the number of reference displays that are signalled in this SEI message. The value of `num_ref_displays_minus1` shall be in the range of 0 to 31, inclusive.

left_view_id[i] indicates the `ViewId` of the left view of a stereo pair corresponding to the *i*-th reference display.

right_view_id[i] indicates the `ViewId` of the right view of a stereo-pair corresponding to the *i*-th reference display.

exponent_ref_display_width[i] specifies the exponent part of the reference display width of the *i*-th reference display. The value of `exponent_ref_display_width[i]` shall be in the range of 0 to 62, inclusive. The value 63 is reserved for future use by ITU-T | ISO/IEC. Decoders shall treat the value 63 as indicating an unspecified reference display width.

mantissa_ref_display_width[i] specifies the mantissa part of the reference display width of the *i*-th reference display. The variable `refDispWidthBits` specifying the number of bits of the `mantissa_ref_display_width[i]` syntax element is derived as follows:

- If `exponent_ref_display_width[i]` is equal to 0, `refDispWidthBits` is set equal to $\text{Max}(0, \text{prec_ref_display_width} - 30)$.
- Otherwise ($0 < \text{exponent_ref_display_width}[i] < 63$), `refDispWidthBits` is set equal to $\text{Max}(0, \text{exponent_ref_display_width}[i] + \text{prec_ref_display_width} - 31)$.

exponent_ref_viewing_distance[i] specifies the exponent part of the reference viewing distance of the *i*-th reference display. The value of `exponent_ref_viewing_distance[i]` shall be in the range of 0 to 62, inclusive. The value 63 is reserved for future use by ITU-T | ISO/IEC. Decoders shall treat the value 63 as indicating an unspecified reference display width.

mantissa_ref_viewing_distance[i] specifies the mantissa part of the reference viewing distance of the *i*-th reference display. The variable `refViewDistBits` specifying the number of bits of the `mantissa_ref_viewing_distance[i]` syntax element is derived as follows:

- If `exponent_ref_viewing_distance[i]` is equal to 0, the `refViewDistBits` is set equal to $\text{Max}(0, \text{prec_ref_viewing_distance} - 30)$.
- Otherwise ($0 < \text{exponent_ref_viewing_distance}[i] < 63$), `refViewDistBits` is set equal to $\text{Max}(0, \text{exponent_ref_viewing_distance}[i] + \text{prec_ref_viewing_distance} - 31)$.

The variables in the *x* row of Table G.2 are derived from the respective variables or values in the *e*, *n*, and *v* rows of Table G.2 as follows:

- If *e* is not equal to 0, the following applies:

$$x = 2^{(e-31)} * (1 + n \div 2^v) \quad (\text{G-6})$$

- Otherwise (*e* is equal to 0), the following applies:

$$x = 2^{-(30+v)} * n \quad (\text{G-7})$$

NOTE 2 The above specification is similar to that found in IEC 60559:1989.

Table G.2 — Association between camera parameter variables and syntax elements

x	refDisplayWidth[i]	refViewingDistance[i]
e	exponent_ref_display_width[i]	exponent_ref_viewing_distance[i]
n	mantissa_ref_display_width[i]	mantissa_ref_viewing_distance[i]
v	refDispWidthBits	refViewDistBits

additional_shift_present_flag[i] equal to 1 indicates that the information about additional horizontal shift of the left and right views for the i-th reference display is present in this SEI message. **additional_shift_present_flag**[i] equal to 0 indicates that the information about additional horizontal shift of the left and right views for the i-th reference display is not present in this SEI message.

num_sample_shift_plus512[i] indicates the recommended additional horizontal shift for a stereo pair corresponding to the i-th reference baseline and the i-th reference display.

- If (**num_sample_shift_plus512**[i] – 512) is less than 0, it is recommended that the left view of the stereo pair corresponding to the i-th reference baseline and the i-th reference display is shifted in the left direction by (512 – **num_sample_shift_plus512**[i]) samples with respect to the right view of the stereo pair.
- Otherwise, if **num_sample_shift_plus512**[i] is equal to 512, it is recommended that shifting is not applied.
- Otherwise, ((**num_sample_shift_plus512**[i] – 512) is greater than 0), it is recommended that the left view in the stereo pair corresponding to the i-th reference baseline and the i-th reference display should be shifted in the right direction by (512 – **num_sample_shift_plus512**[i]) samples with respect to the right view of the stereo pair.

The value of **num_sample_shift_plus512**[i] shall be in the range of 0 to 1023, inclusive.

NOTE 3 Shifting the left view in the left (or right) direction by x samples with respect to the right view can be performed by the following two-step processing:

- 1) Shift the left view by x / 2 samples in the left (or right) direction, and shift the right view by x / 2 samples in the right (or left) direction.
- 2) Fill the left and right image margins of x / 2 samples in width in both the left and right views in background colour.

The following pseudo code explains the recommended shifting processing in the case of shifting the left view in the left direction by x samples with respect to the right view:

```

for( i = x / 2; i < width - x / 2; i++ )
    for( j = 0; j < height; j++ ) {
        leftView[ j ][ i ] = leftView[ j ][ i + x / 2 ]
        rightView[ j ][ width - 1 - i ] = rightView[ j ][ width - 1 - i - x / 2 ]
    }
for( i = 0; i < x / 2; i++ )
    for( j = 0; j < height; j++ ) {
        leftView[ j ][ width - 1 - i ] = leftView[ j ][ i ] = backgroundColour
        rightView[ j ][ width - 1 - i ] = rightView[ j ][ i ] = backgroundColour
    }
    
```

(G-8)

The following pseudo code explains the recommended shifting processing in the case of shifting the left view in the right direction by x samples with respect to the right view:

```

for( i = x / 2; i < width - x / 2; i++ )
    for( j = 0; j < height; j++ ) {
        leftView[j][ width - 1 - i ] = leftView[j][ width - 1 - i - x / 2 ]
        rightView[j][ i ] = rightView[j][ i + x / 2 ]
    }
for( i=0; i < x / 2; i++ )
    for( j = 0; j < height; j++ ) {
        leftView[j][ width - 1 - i ] = leftView[j][ i ] = backgroundColour
        rightView[j][ width - 1 - i ] = rightView[j][ i ] = backgroundColour
    }

```

(G-9)

The variable `backgroundColour` may take different values in different systems, for example black or gray.

three_dimensional_reference_displays_extension_flag equal to 0 indicates that no additional data follows within the reference displays SEI message. The value of `three_dimensional_reference_displays_extension_flag` shall be equal to 0 in bitstreams conforming to this version of this document. The value of 1 for `three_dimensional_reference_displays_extension_flag` is reserved for future use by ITU-T | ISO/IEC. Decoders shall ignore all data that follow the value of 1 for `three_dimensional_reference_displays_extension_flag` in a reference displays SEI message.

G.14.3.4 Depth representation information SEI message semantics

G.14.3.4.1 General

The syntax elements in the depth representation information SEI message specify various parameters for auxiliary pictures of type `AUX_DEPTH` for the purpose of processing decoded primary and auxiliary pictures prior to rendering on a 3D display, such as view synthesis. Specifically, depth or disparity ranges for depth pictures are specified.

When present, the depth representation information SEI message shall be associated with one or more layers with `AuxId` value equal to `AUX_DEPTH`. The following semantics apply separately to each `nuh_layer_id` `targetLayerId` among the `nuh_layer_id` values to which the depth representation information SEI message applies.

When present, the depth representation information SEI message may be included in any access unit. It is recommended that, when present, the SEI message is included for the purpose of random access in an access unit in which the coded picture with `nuh_layer_id` equal to `targetLayerId` is an IRAP picture.

For an auxiliary picture with `AuxId[targetLayerId]` equal to `AUX_DEPTH`, an associated primary picture, if any, is a picture in the same access unit having `AuxId[nuhLayerIdB]` equal to 0 such that `ScalabilityId[LayerIdxInVps[targetLayerId]][j]` is equal to `ScalabilityId[LayerIdxInVps[nuhLayerIdB]][j]` for all values of j in the range of 0 to 2, inclusive, and 4 to 15, inclusive.

The information indicated in the SEI message applies to all the pictures with `nuh_layer_id` equal to `targetLayerId` from the access unit containing the SEI message up to but excluding the next picture, in decoding order, associated with a depth representation information SEI message applicable to `targetLayerId` or to the end of the CLVS of the `nuh_layer_id` equal to `targetLayerId`, whichever is earlier in decoding order.

z_near_flag equal to 0 specifies that the syntax elements specifying the nearest depth value are not present in the syntax structure. **z_near_flag** equal to 1 specifies that the syntax elements specifying the nearest depth value are present in the syntax structure.

z_far_flag equal to 0 specifies that the syntax elements specifying the farthest depth value are not present in the syntax structure. **z_far_flag** equal to 1 specifies that the syntax elements specifying the farthest depth value are present in the syntax structure.