

INTERNATIONAL  
STANDARD

**ISO/IEC**  
**8802-5**

**ANSI/IEEE**  
**Std 802.5**

Second edition  
1995-12-29

---

---

**Information technology —  
Telecommunications and information  
exchange between systems — Local and  
metropolitan area networks — Specific  
requirements —**

**Part 5:**

Token ring access method and physical layer  
specifications

*Technologies de l'information — Télécommunications et échange  
d'information entre systèmes — Réseaux locaux et urbains — Exigences  
spécifiques —*

*Partie 5: Méthode d'accès par anneau à jeton et spécifications pour la  
couche physique*



Reference number  
ISO/IEC 8802-5:1995(E)  
ANSI/IEEE  
Std 802.5, 1995 edition

**Abstract:** This Local and Metropolitan Area Network standard, ISO/IEC 8802-5 : 1995, is part of a family of local area network (LAN) standards dealing with the physical and data link layers as defined by the ISO Open System Interconnection Reference Model. Its purpose is to provide compatible interconnection of data processing equipment by means of a local area network using the token-passing ring access method. The frame format, including delimiters, addressing, and priority stacks, are defined. The MAC protocol is defined. The finite-state machine and state tables are supplemented with a prose description of the algorithms. The physical layer (PHY) functions of symbol encoding and decoding, symbol time, and latency buffering are defined. The services provided by the MAC to the station management (SMT) and the services provided by the PHY to SMT and the MAC are described. These services are defined in terms of service primitives and associated parameters. The 4 and 16 Mbit/s, shielded twisted pair attachment of the station to the medium, including the medium interface connector (MIC) are also defined. The applications environments for the LAN is intended to be commercial and light industrial. The use of token ring LANs in home and heavy industrial environments, while not precluded, has not been considered in the development of the standard. A Protocol Implementation Conformance Statement (PICS) proforma is provided as an annex to the standard.

**Keywords:** data processing interconnection, local area network (LAN), medium access control (MAC), token ring

---

The Institute of Electrical and Electronics Engineers, Inc.  
345 East 47th Street, New York, NY 10017-2394, USA

Copyright © 1995 by the Institute of Electrical and Electronics Engineers, Inc.  
All rights reserved. Published 1995. Printed in the United States of America.

ISBN 1-55937-540-X

*No part of this publication may be reproduced in any form, in an electronic retrieval system or otherwise, without the prior written permission of the publisher.*

December 29, 1995

SH94304

**ISO/IEC 8802-5 : 1995**

**ANSI/IEEE Std 802.5-1995**

(Revision of ISO/IEC 8802-5 : 1992 [ANSI/IEEE Std 802.5-1992],  
incorporating ISO/IEC TR 10738 : 1992 [ANSI/IEEE Std 802.5b-1991])

**Information technology—  
Telecommunications and information  
exchange between systems—  
Local and metropolitan area networks—  
Specific requirements**

**Part 5: Token ring access method and  
physical layer specifications**

Sponsor

**Technical Committee on Computer Communications  
of the  
IEEE Computer Society**

STANDARDSISO.COM Click to view the full PDF of ISO/IEC 8802-5:1995

# International Standard ISO/IEC 8802-5: 1995

ISO (the International Organization for Standardization) and IEC (the International Electrotechnical Commission) form the specialized system for worldwide standardization. National bodies that are members of ISO or IEC participate in the development of International Standards through technical committees established by the respective organization to deal with particular fields of technical activity. ISO and IEC technical committees collaborate in fields of mutual interest. Other international organizations, governmental and nongovernmental, in liaison with ISO and IEC, also take part in the work.

In the field of information technology, ISO and IEC have established a joint technical committee, ISO/IEC JTC 1. Draft International Standards adopted by the joint technical committee are circulated to national bodies for voting. Publication as an International Standard requires approval by at least 75% of the national bodies casting a vote.

International Standard ISO/IEC 8802-5 was prepared by Joint Technical Committee ISO/IEC JTC 1, *Information technology*.

This second edition cancels and replaces the first edition (ISO/IEC 8802-5: 1992), which has been technically revised. This edition also supersedes ISO/IEC TR 10738: 1992.

ISO/IEC 8802 consists of the following parts, under the general title *Information technology—Local and metropolitan area networks*:

- *Part 1: Overview and Architecture*
- *Part 2: Logical link control*
- *Part 3: Carrier sense multiple access with collision detection (CSMA/CD) access method and physical layer specifications*
- *Part 4: Token-passing bus access method and physical layer specifications*
- *Part 5: Token ring access method and physical layer specifications*
- *Part 6: Distributed Queue Dual Bus (DQDB) access method and physical layer specifications*
- *Part 7: Slotted ring access method and physical layer specification*

For the purpose of assigning organizationally unique identifiers, the Institute of Electrical and Electronics Engineers, Inc., USA, has been designated by the ISO and IEC Councils as the Registration Authority. Communications on this subject should be addressed to

Registration Authority for ISO/IEC 8802-5  
c/o The Institute of Electrical and Electronics Engineers, Inc.  
445 Hoes Lane  
P.O. Box 1331  
Piscataway, NJ 08855-1331  
USA

During the preparation of this International Standard, information was gathered on patents upon which application of the standard might depend. Relevant patents were identified as belonging to Willemijn Holding BV. However, ISO and IEC cannot give authoritative or comprehensive information about evidence, validity or scope of patent and like rights. The patent-holder has stated that licenses will be granted under reasonable terms and conditions and communications on this subject should be addressed to

Willemijn Holding BV  
Weena 723  
P.O. Box 29193  
3001 GD Rotterdam  
The Netherlands



International Organization for Standardization/International Electrotechnical Commission  
Case postale 56 • CH-1211 Genève 20 • Switzerland

## Foreword to International Standard ISO/IEC 8802-5 : 1995

This International Standard is part of a family of International Standards for Local and Metropolitan Area Networks. The relationship between this International Standard and the other members of the family is shown below. (The numbers in the figure refer to ISO/IEC Standard numbers.)

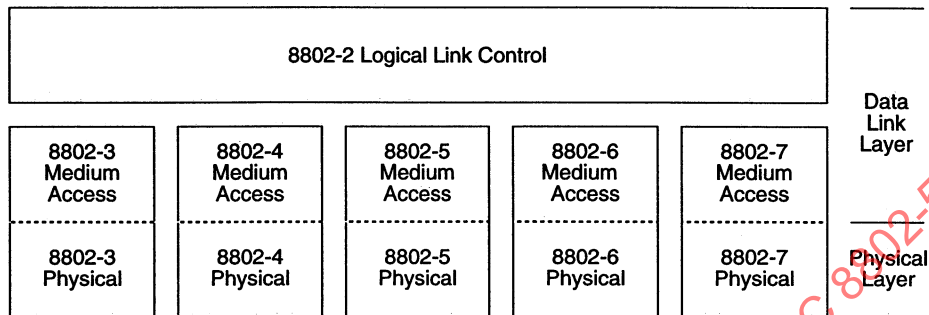

This family of International Standards deals with the Physical and Data Link layers as defined by the ISO Open Systems Interconnection (OSI) Basic Reference Model (ISO/IEC 7498-1 : 1994). The access standards define five types of medium access technologies and associated physical media, each appropriate for particular applications or system objectives. Other types are under investigation.

The International Standards defining the access technologies are as follows:

- a) ISO/IEC 8802-3 [ANSI/IEEE Std 802.3, 1993 Edition], a bus utilizing CSMA/CD as the access method.
- b) ISO/IEC 8802-4 [ANSI/IEEE Std 802.4-1990], a bus utilizing token passing as the access method.
- c) ISO/IEC 8802-5 [ANSI/IEEE Std 802.5-1995], a ring utilizing token passing as the access method.
- d) ISO/IEC 8802-6 [ANSI/IEEE Std 802.6, 1994 Edition], a dual bus utilizing distributed queuing as the access method.
- e) ISO 8802-7, a ring utilizing slotted ring as the access method.

ISO/IEC 8802-2 [ANSI/IEEE Std 802.2, 1994 Edition], *Logical Link Control*, is used in conjunction with the medium access standards to provide the data link layer service to network layer protocols.

ISO/IEC 15802-2 [IEEE Std 802.1B-1992 and 802.1k-1993], *LAN/MAN Management*, Defines an OSI management-compatible architecture, and services and protocol elements for use in a LAN/MAN environment for performing remote management.

ISO/IEC 10038 [ANSI/IEEE Std 802.1D, 1993 Edition], *Media Access Control (MAC) bridges*, specifies an architecture and protocol for the interconnection of IEEE 802 LANs below the level of the logical link control protocol.

The reader of this document is urged to become familiar with the complete family of International Standards.

The main body of the International Standard serves for both the ISO/IEC 8802-2 : 1994 and IEEE Std 802.2, 1994 Edition standards. ISO and IEEE each have a unique foreword.

## ANSI/IEEE Std 802.5-1995

**IEEE Standards** documents are developed within the Technical Committees of the IEEE Societies and the Standards Coordinating Committees of the IEEE Standards Board. Members of the committees serve voluntarily and without compensation. They are not necessarily members of the Institute. The standards developed within IEEE represent a consensus of the broad expertise on the subject within the Institute as well as those activities outside of IEEE that have expressed an interest in participating in the development of the standard.

Use of an IEEE Standard is wholly voluntary. The existence of an IEEE Standard does not imply that there are no other ways to produce, test, measure, purchase, market, or provide other goods and services related to the scope of the IEEE Standard. Furthermore, the viewpoint expressed at the time a standard is approved and issued is subject to change brought about through developments in the state of the art and comments received from users of the standard. Every IEEE Standard is subjected to review at least every five years for revision or reaffirmation. When a document is more than five years old and has not been reaffirmed, it is reasonable to conclude that its contents, although still of some value, do not wholly reflect the present state of the art. Users are cautioned to check to determine that they have the latest edition of any IEEE Standard.

Comments for revision of IEEE Standards are welcome from any interested party, regardless of membership affiliation with IEEE. Suggestions for changes in documents should be in the form of a proposed change of text, together with appropriate supporting comments.

**Interpretations:** Occasionally questions may arise regarding the meaning of portions of standards as they relate to specific applications. When the need for interpretations is brought to the attention of IEEE, the Institute will initiate action to prepare appropriate responses. Since IEEE Standards represent a consensus of all concerned interests, it is important to ensure that any interpretation has also received the concurrence of a balance of interests. For this reason IEEE and the members of its technical committees are not able to provide an instant response to interpretation requests except in those cases where the matter has previously received formal consideration.

Comments on standards and requests for interpretations should be addressed to:

Secretary, IEEE Standards Board  
445 Hoes Lane  
P.O. Box 1331  
Piscataway, NJ 08855-1331  
USA

IEEE standards documents may involve the use of patented technology. Their approval by the Institute of Electrical and Electronics Engineers does not mean that using such technology for the purpose of conforming to such standards is authorized by the patent owner. It is the obligation of the user of such technology to obtain all necessary permissions.

# Introduction to ANSI/IEEE Std 802.5-1995

(This introduction is not a part of ANSI/IEEE Std 802.5-1995 or of ISO/IEC 8802-5 : 1995.)

This standard is part of a family of standards for local and metropolitan area networks. The relationship between the standard and other members of the family is shown below. (The numbers in the figure refer to IEEE standard numbers.)

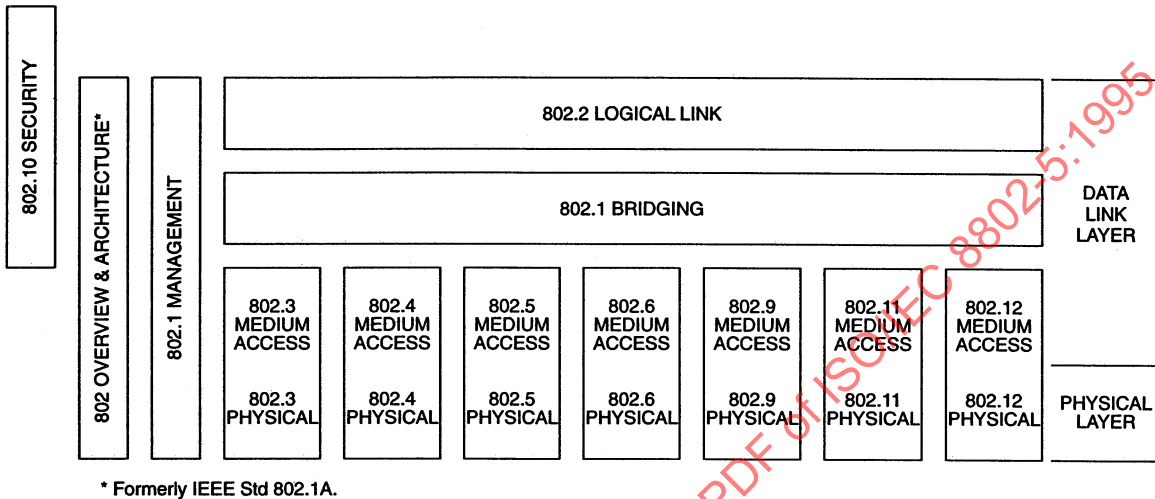

This family of standards deals with the Physical and Data Link Layers as defined by the International Organization for Standardization (ISO) Open Systems Interconnection Basic Reference Model (ISO 7498 : 1984). The access standards define several types of medium access technologies and associated physical media, each appropriate for particular applications or system objectives. Other types are under investigation.

The standards defining these technologies are as follows:

- IEEE Std 802<sup>a</sup>: Overview and Architecture. This standard provides an overview to the family of IEEE 802 Standards. This document forms part of the 802.1 scope of work.
- IEEE Std 802.1B and 802.1k [ISO/IEC 15802-2]: LAN/MAN Management. Defines an Open Systems Interconnection (OSI) management-compatible architecture, and services and protocol elements for use in a LAN/MAN environment for performing remote management.
- ANSI/IEEE Std 802.1D [ISO/IEC 10038]: MAC Bridging. Specifies an architecture and protocol for the interconnection of IEEE 802 LANs below the MAC service boundary.
- ANSI/IEEE Std 802.1E [ISO/IEC 15802-4]: System Load Protocol. Specifies a set of services and protocol for those aspects of management concerned with the loading of systems on IEEE 802 LANs.

<sup>a</sup>The 802 Architecture and Overview Specification, originally known as IEEE Std 802.1A, has been renumbered as IEEE Std 802. This has been done to accommodate recognition of the base standard in a family of standards. References to IEEE Std 802.1A should be considered as references to IEEE Std 802.

- ISO 8802-2 [ANSI/IEEE Std 802.2]: Logical Link Control
- ISO/IEC 8802-3 [ANSI/IEEE Std 802.3]: CSMA/CD Access Method and Physical Layer Specifications
- ISO/IEC 8802-4 [ANSI/IEEE Std 802.4]: Token Bus Access Method and Physical Layer Specifications
- ISO/IEC 8802-5 [ANSI/IEEE Std 802.5]: Token Ring Access Method and Physical Layer Specifications
- ISO/IEC 8802-6 [ANSI/IEEE Std 802.6]: Distributed Queue Dual Bus Access Method/Physical Layer Specifications
- IEEE Std 802.9 Integrated Services (IS) LAN Interface at the Medium Access Control (MAC) and Physical Layers
- IEEE Std 802.10: Interoperable LAN/MAN Security, *Currently approved:* Secure Data Exchange
- IEEE Std 802.12 Demand Priority Access Method and Physical Layer Specifications

In addition to the family of standards, the following is a recommended practice for a common Physical Layer technology:

- IEEE Std 802.7: IEEE Recommended Practice for Broadband Local Area Networks

The following additional working groups have authorized standards projects under development:

- IEEE 802.11 Wireless LAN Medium Access Control (MAC)/Physical Layer Specifications
- IEEE 802.14 Standard Protocol for Cable-TV Based Broadband Communication Network

The reader of this standard is urged to become familiar with the complete family of standards.

### Conformance test methodology

An additional standards series, identified by the number 1802, has been established to identify the conformance test methodology documents for the 802 family of standards. Thus the conformance test documents for 802.3 are numbered 1802.3, the conformance test documents for 802.5 will be 1802.5, and so on. Similarly, ISO will use 18802 to number conformance test standards for 8802 standards.

### ANSI/IEEE Std 802.5 [ISO/IEC 8802-5 : 1995]

This standard specifies that each octet of the information field shall be transmitted most significant bit (MSB) first. This convention is reversed from that used in the CSMA/CD and Token Bus standards, which are least significant bit (LSB) first transmission. While the transmission of MSB first is used for token ring, this does not imply that MSB transmission is preferable.

## Participants

The following is a list of those who were members of the IEEE 802.5 Working Group when this standard was approved:

**Jim Carlo, Chair**  
**Bob Donnan, Editor-in-Chief<sup>c</sup>**  
**John Creigh, Technical Editor<sup>d</sup>**  
**Bill Futral, Technical Editor<sup>e</sup>**  
**Tricia Hill, Technical Editor<sup>f</sup>**  
**Kirk Preiss, Technical Editor<sup>g</sup>**  
**Kenneth T. Wilson, Technical Editor<sup>h</sup>**

Luc W. Adriaenssens  
John Allen  
Dave Allmond  
Fabrice Autrique  
Joseph W. Ayers  
Evan J. Bontemps  
Timothy Brooks  
Robert R. Campbell  
Johnny A. Chang  
Robert Dalgleish  
Seamus Daly  
Tom Daly  
John DeCramer  
Hans Peter Dittler  
Ameesh Divatia  
George Duane  
Phillip A. Emer  
Tedd M. Frechette  
Ray Freer  
Mark French  
Nathan Fritts  
Eric Fuh

John Griesing  
Julio Guerra  
Martin Guthrie  
Sharam Hakimi  
David E. Hammond  
Steve Hamner  
Carl G. Hayssen  
Douglas Ingraham  
Allen Jett  
Kris Kalbarczyk  
Allen Kasey  
David Kutilek  
George Lin  
Carl Lindeborg  
Michel Lissillour  
Mark Loney  
Robert D. Love  
Alan C. Marshall  
Juan Martin  
Kelly P. McClellan  
James McDade  
John Messenger

John E. Montague  
Teruo Moriguchi  
Kathleen Otis  
Dave Pearce  
William Proulx  
Ivan A. Reede  
Phil Robinson  
Bob Ross  
Bill Sarles  
Dieter Schichetanz  
Himanshu Shah  
Bharat Singh  
Raymond Sit  
Richard Sweatt  
John Ta  
Jeff Tong  
Bish Turley  
Carol Weinreich  
Steven Weiss  
Edward C. Wong  
Robert Wu  
Charles Yager

<sup>c</sup> Clause 1, 2; Annex A

<sup>d</sup> Clauses 7; Annexes B, C, D, E

<sup>e</sup> Clauses 3, 4, 5, 6; Annexes G, H

<sup>f</sup> Clause 8

<sup>g</sup> Clause I

<sup>h</sup> Clause F

STANDARDSISO.COM : Click to view the full PDF of ISO/IEC 802.5:1995

The following persons were on the balloting committee:

William B. Adams	Yongbum Kim	Philip T. Robinson
Kit Athul	Lathia Kiritkumar	Edouard Y. Rocher
William E. Ayen	Stephen B. Kruger	James W. Romlein
Kym D. Blair	Kenneth C. Kung	Daniel Rosich
Michael J. Caldwell	Randolph S. Little	Floyd E. Ross
Peter K. Campbell	Donald C. Loughry	Frederick E. Sauer
James Carlo	Robert D. Love	Gregory D. Schumacher
John Cronican	Peter Martini	Moe Shahdad
Robert Crowder	Ann Miller	Donald A. Sheppard
Robert Donnan	David S. Millman	Michael S. Siegel
Sourav K. Dutta	Melody W. Moh	Rosemary Slager
Paul Eastman	David J. Morris	Efstathiois D. Sykas
John E. Emrich	James R. Moulton	Daniel Sze
Philip H. Enslow	Donal O'Mahony	Geoffrey O. Thompson
John W. Fendrich	Charles Oestereicher	Robert Tripi
Michael Fischer	Thomas L. Phinney	Mark-Rene Uchida
Robert J. Gagliano	Art Pina	James T. Vorhies
Karunakar Gulukota	Rafat Pirzada	Barry M. Vormbrock
J. Scott Haugdahl	Kirk Preiss	Donald F. Weir
Clark M. Hay	Andris Putnins	Alan J. Weissberger
Jack R. Johnson	Yang Qianli	Raymond Wenig
Henry D. Keen	Fernando Ramos	Kenneth T. Wilson
Peter M. Kelly	Thad L. Regulinski	Jerry A. Wyatt
Gary C. Kessler	John P. Riganati	Oren Yuen

When the IEEE Standards Board approved this standard on June 14, 1995, it had the following membership:

**E. G. "Al" Kiener, Chair**

**Donald C. Loughry, Vice Chair**

**Andrew G. Salem, Secretary**

Gilles A. Baril	Richard J. Holleman	Marco W. Migliaro
Clyde R. Camp	Jim Isaak	Mary Lou Padgett
Joseph A. Cannatelli	Ben C. Johnson	John W. Pope
Stephen L. Diamond	Sonny Kasturi	Arthur K. Reilly
Harold E. Epstein	Lorraine C. Kevra	Gary S. Robinson
Donald C. Fleckenstein	Ivor N. Knight	Ingo Rusch
Jay Forster*	Joseph L. Koepfinger*	Chee Kiow Tan
Donald N. Heirman	D. N. "Jim" Logothetis	Leonard L. Tripp
	L. Bruce McClung	

\*Member Emeritus

Also included are the following nonvoting IEEE Standards Board liaisons:

Satish K. Aggarwal  
Richard B. Engelman  
Robert E. Hebner  
Chester C. Taylor

Paula M. Kelty  
*IEEE Standards Project Editor*

ISO/IEC 8802-5 : 1995 [ANSI/IEEE Std 802.5-1995] was approved by the American National Standards Institute (ANSI) on December 1, 1995.

# Contents

CLAUSES	PAGE
1. Overview.....	1
1.1 Scope.....	1
1.2 Normative references .....	3
1.3 Definitions.....	4
1.4 Conventions .....	9
1.5 Abbreviations and acronyms.....	9
1.6 Conformance requirements—station .....	12
1.7 Conformance requirements—concentrator.....	13
1.8 Local regulations.....	13
2. General description .....	14
2.1 Architectural view.....	14
2.2 Station functional organization and data flow .....	14
2.3 Physical structure of a token ring network .....	17
2.4 Data stations, servers, and system management .....	18
3. Formats and facilities.....	20
3.1 Formats .....	20
3.2 Field descriptions.....	21
3.3 Medium Access Control (MAC) frames.....	29
3.4 System timing parameters.....	39
3.5 Station policy flags .....	42
3.6 Error counters.....	44
4. Token ring protocols.....	46
4.1 Overview.....	46
4.2 Specification definitions .....	60
4.3 Token ring MAC protocol specification .....	77
5. Station-specific components .....	102
5.1 General.....	102
5.2 Data signaling rate .....	107
5.3 Symbol coding (differential Manchester 1, 0, J, K).....	108
5.4 Repeat path.....	109
5.5 Symbol encoder .....	109
5.6 Symbol decoder .....	110
5.7 Symbol acquisition/loss .....	110
5.8 Latency.....	111
5.9 Ring access control .....	113
6. Token ring management .....	114
6.1 Station management primitives.....	114
6.2 Token ring station managed objects .....	120

CLAUSES	PAGE
7. Station attachment specifications.....	141
7.1 Media-independent PHY specifications .....	141
7.2 Media-dependent PMC specifications .....	143
8. Concentrator specifications.....	170
8.1 Concentrator lobe port .....	170
8.2 Concentrator trunk ports .....	172
8.3 Ring access control function.....	173
8.4 Passive concentrator.....	175
8.5 Active retiming concentrator .....	179

#### ANNEXES

Annex A (normative) Protocol Implementation Conformance Statement (PICS) proforma.....	181
Annex B (normative) Channel design considerations.....	196
Annex C (informative) Jitter considerations .....	208
Annex D (informative) Transmitter example.....	218
Annex E (informative) Safety and environmental considerations .....	220
Annex F (informative) Low-level finite-state machines (FSMs) .....	222
Annex G (informative) Differences from 1992 version.....	227
Annex H (informative) Example of a MAC frame parsing algorithm .....	231
Annex I (informative) Recommended use of priorities for token ring .....	233
Annex J (informative) Bibliography .....	239

**Information technology—  
Telecommunications and information  
exchange between systems—  
Local and metropolitan area networks—  
Specific requirements—**

**Part 5: Token ring access method and physical  
layer specifications**

**1. Overview**

**1.1 Scope**

For the purpose of compatible interconnection of data processing equipment via a local area network (LAN) using the token ring access method, this part of ISO/IEC 8802.

- a) Provides a general description of the token ring local area network (LAN) architecture (clause 2);
- b) Defines the frame format, including the delimiters, address fields, information field, and frame-check sequence (FCS). Defines the Medium Access Control (MAC) frames, timers, and error counters (clause 3);
- c) Defines the MAC protocols including finite-state machines and state tables (clause 4);
- d) Defines the system level Physical layer (PHY) signaling specifications that are specific to a ring station (clause 5);
- e) Defines the managed objects necessary to manage the service and protocol elements that are involved in the management of a token ring station (clause 6);
- f) Defines the PHY station attachment specification for 4 and 16 Mbit/s operation. This includes the transmitter, receiver, medium interface connector, and transmission channel for both shielded twisted pair (STP) and unshielded twisted pair (UTP) medium (clause 7);
- g) Defines the concentrator, incorporating multiple trunk coupling units (TCUs), for the attachment of a group of stations to the ring (clause 8);

- h) Includes the protocol implementation conformance statement (PICS) proforma in compliance with the relevant requirements, and in accordance with the relevant guidance, given in ISO/IEC 9646-2 : 1994<sup>1</sup> (annex A);
- i) Includes channel design examples and formulas for calculating cabling and concentrator system configurations (annex B);
- j) Describes jitter components and provides an example of jitter buildup using a phase lock loop recovery circuit (annex C);
- k) Provides informative transmitter filter design example (annex D);
- l) Provides recommended guidelines for safety and operating environments (annex E);
- m) Illustrates the MAC finite-state machines in a notation similar to that used in ISO/IEC 8802-5 : 1992 (annex F);
- n) Describes major improvements between this standard and the previous edition, ISO/IEC 8802-5 : 1992 (annex G);
- o) Provides a sample algorithm for the parsing of MAC frames (annex H);
- p) Provides recommendations for the use of token ring access priorities to support multimedia traffic (annex I).

A particular emphasis of this standard is to specify the externally visible characteristics needed for interconnection compatibility, while avoiding unnecessary constraints upon and changes to internal design and implementation of the heterogeneous processing equipment to be interconnected.

The applications environment for the LAN is intended to be commercial and light industrial. The use of token ring LANs in home and heavy industrial environments, while not precluded, has not been considered in the development of this standard.

This standard, the Second Edition of part of ISO/IEC 8802, provides greater specificity and improved clarity to the First Edition (1992-06-12) to ensure interoperability of the various components in the token ring network. The intent of this standard is to maintain interoperability with stations designed to this specification and stations designed to the prior standard. However, interoperability with prior implementations (particularly in regard to clause 7) cannot be guaranteed due to nonspecificity within the 1992 edition. Annex G lists the specific differences between the second edition and the first edition.

The following items are subjects for future study:

- a) Controlled bit altering by any device except a station.
- b) Methodology to assure handling of joining of multiple rings as may be used by managed concentrators to assure normal insertion process protection mechanisms (such as duplicate address test or ring parameter server notification).
- c) Ring data rate determination to allow managed data rate adaptation between stations.
- d) Alternative active concentrators or repeaters that provide increased cabling distances and/or enhanced operation of rings containing devices built to the first edition of this standard, ISO/IEC 8802-5 : 1992.
- e) Converters that allow the interconnection of stations on different media types.
- f) Methodologies to provide enhanced transmission reliability over the trunk cable.
- g) Definition of concentrator managed objects.

<sup>1</sup> Information on references can be found in clause 1.2.

## 1.2 Normative references

The following standards contain provisions which, through reference in this text, constitute provisions of this part of ISO/IEC 8802. At the time of publication, the editions indicated were valid. All standards are subject to revision, and parties to agreements based on ISO/IEC 8802-5 : 1995 are encouraged to investigate the possibility of applying the most recent editions of the standards indicated below. Members of ISO and IEC maintain registers of currently valid International Standards.

CISPR Publication 22 : 1985, Limits and Methods of Measurement of Radio Interference Characteristics of Information Technology Equipment.<sup>2</sup>

IEC 73 : 1991, Coding of indicating device actuators by colors and supplementary means.<sup>3</sup>

IEC 603-7 : 1990, Connectors for frequencies below 3 MHz for use with printed boards—Part 7: Detail specification for connectors, 8-way, including fixed and free connectors with common mating features.

IEC 950 : 1991, Safety of information technology equipment, including electrical business equipment.

ISO/IEC 7498-1 : 1994, Information technology—Open Systems Interconnection—Basic Reference Model: The Basic Model.<sup>4</sup>

ISO/IEC 7498-4 : 1989, Information processing systems—Open Systems Interconnection—Basic Reference Model—Part 4: Management framework.

ISO/IEC 8802-2 : 1994 [ANSI/IEEE Std 802.2, 1994 Edition], Information technology—Telecommunications and information exchange between systems—Local and metropolitan area networks—Specific requirements—Part 2: Logical link control.<sup>5</sup>

ISO/IEC 8824 : 1990, Information technology—Open Systems Interconnection—Specification of Abstract Syntax Notation One (ASN.1).

ISO/IEC 9646-1 : 1994, Information technology—Open Systems Interconnection—Conformance testing methodology and framework—Part 1: General concepts.

ISO/IEC 9646-2 : 1994, Information technology—Open Systems Interconnection—Conformance testing methodology and framework—Part 2: Abstract Test Suite specification.

ISO/IEC 10038 : 1993 [ANSI/IEEE Std 802.1D, 1993 Edition], Information technology—Telecommunication and information exchange between systems—Local area networks—Media access control (MAC) bridges.

ISO/IEC 10165-2 : 1992, Information technology—Open Systems Interconnection—Structure of Management Information: Definition of management information.

ISO/IEC 10742 : 1994, Information technology—Telecommunications and information exchange between systems—Elements of management information related to OSI Data Link Layer standards.

<sup>2</sup> CISPR and IEC publications are available from the International Electrotechnical Commission, 3, rue de Varembe, Case Postale 131, CH-1211, Genève 20, Switzerland/Suisse. These publications are also available in the United States from the Sales Department, American National Standards Institute, 11 West 42nd Street, 13th Floor, New York, NY 10036, USA.

<sup>3</sup> See footnote 2.

<sup>4</sup> ISO/IEC publications are available from ISO, Case Postale 56, 1, rue de Varembe, CH-1211, Genève 20, Switzerland/Suisse. These publications are also available in the United States from the Sales Department, American National Standards Institute, 11 West 42nd Street, 13th Floor, New York, NY 10036, USA.

<sup>5</sup> ISO/IEC [ANSI/IEEE] are available from ISO. They are also available from the Institute of Electrical and Electronics Engineers, 445 Hoes Lane, P.O. Box 1331, Piscataway, NJ 08855-1331, USA.

ISO/IEC 11801 : 1995, Information technology—Generic cabling for customer premises.

ISO/IEC TR 11802-2 : 1995, Information technology—Telecommunications and information exchange between systems—Local and metropolitan area networks—Technical reports and guidelines—Part 2: Standard Group MAC Addresses.

ISO/IEC TR 11802-4 : 1994, Information technology—Telecommunications and information exchange between systems—Local and metropolitan area networks—Technical reports and guidelines—Part 4: Token ring access method and physical layer specifications—Fibre optic station attachment.

ISO/IEC 15802-1 : 1995, Information technology—Telecommunications and information exchange between systems—Local and metropolitan area networks—Common specifications—Part 1: Medium Access Control (MAC) service definition. (Previously ISO/IEC 10039 : 1991/PDAM 1).

ISO/IEC 15802-2 : 1995 [ANSI/IEEE Std 802.1B-1992 and ANSI/IEEE Std 802.1k-1993], Information technology—Telecommunications and information exchange between systems—Local and metropolitan area networks—Common specifications—Part 2: LAN/MAN management, service, protocol.

### 1.3 Definitions

**1.3.1 abort sequence:** A sequence transmitted by an originating ring station that terminates the transmission of a frame prematurely. It also causes the ring station receiving this frame to terminate the frame's reception.

**1.3.2 accumulated jitter:** The jitter at a PHY entity in the ring measured against the transmit clock of the active monitor. It is the total jitter accumulated by all the stations from the active monitor to the measurement point. It is typically used to determine the required size of the elastic buffer.

**1.3.3 active monitor:** A station on the ring that is performing certain functions to ensure proper operation of the ring. These functions include 1) establishing clock reference for the ring; 2) assuring that a usable token is available; 3) initiating the neighbor notification cycle; 4) preventing circulating frames and priority tokens. In normal operation only one station on a ring may be the active monitor at any instance in time.

**1.3.4 active retimed concentrator:** A type of token ring concentrator that performs an embedded repeater function in the lobe port's data path, thereby providing ring segment boundaries at the concentrator lobe port connector (CMIC).

**1.3.5 adjusted NEXT loss:** The NEXT loss in decibels of a channel plus  $15\log F/F_{ref}$ , where  $F$  is the measured frequency and  $F_{ref}$  is a reference frequency (4 MHz at 4 Mbit/s and 16 Mbit/s). It is used to determine the NEXT to interference (NIR) ratio of a channel.

**1.3.6 alignment error:** Alignment error is the deviation of the recovered clock from the ideal recovered clock embedded by the transmitter. The deviation from the ideal sampling point may be caused by static timing errors in the timing recovery circuit, internal jitter generated in the timing recovery circuit, and the inability to track exactly the jitter on the received data signal.

**1.3.7 backup path:** Secondary transmission path in trunk cabling and concentrator, normally used for token ring signal transmission only when there is a failure on the main ring path.

**1.3.8 beaconing:** A ring state that occurs when a station on the ring has detected a ring failure. The frame transmitted by the station to alert the other stations on the ring of the failure is called a beacon frame.

**1.3.9 bit error rate (BER):** A measurement of error rate stated as a ratio of the number of bits with an error to the total number of bits passing a given point on the ring. A BER of  $10^{-6}$  indicates that an average of one bit per million bits is in error.

- 1.3.10 broadcast:** The act of sending a frame addressed to all stations.
- 1.3.11 burst4:** Exactly four consecutive signal elements of the same polarity.
- 1.3.12 burst5:** Five or more consecutive signal elements of the same polarity.
- 1.3.13 burst6:** Six or more consecutive signal elements of the same polarity.
- 1.3.14 channel:** The data path from any transmitting MIC to the next downstream receiving MIC.
- 1.3.15 claiming:** A ring state that occurs when a station detects that the active monitor functions are not being performed and at least one station is contending to become active monitor.
- 1.3.16 concentrator:** A device that contains multiple interconnected trunk coupling units (TCUs). The concentrator contains two ports, referred to as *ring in* and *ring out*, to interface trunk cable.
- 1.3.17 configuration report server (CRS):** A function that monitors and controls the stations of the ring. It receives configuration information from the stations on the ring and either forwards it to the network manager or uses it to maintain a configuration of the ring. It can also, when requested by a network manager, check the status of stations on the ring, change operational parameters of stations on the ring, and request that a station remove itself from the ring.
- 1.3.18 converter:** A type of repeater that converts the data signal from one media to another.
- 1.3.19 correlated jitter:** The portion of the total jitter that is related to the data pattern. Since every PHY receives the same pattern, this jitter is correlated among all similarly configured PHYs receiving the same data pattern and therefore may grow in a systematic way along the ring. Also referred to as *pattern jitter* or *systematic jitter*.
- 1.3.20 crosstalk:** Crosstalk is undesired energy appearing in one signal path as a result of coupling from other signal paths.
- 1.3.21 cumulative latency:** The time it takes for a signal element to travel from the active monitor's transmitter output to its receiver input.
- 1.3.22 differential Manchester encoding:** A signaling method used to encode clock and data bit information into bit symbols. Each bit symbol is split into two halves, or signal elements, where the second half is the inverse of the first half. A 0 bit is represented by a polarity change at the start of the bit time. A 1 bit is represented by no polarity change at the start of the bit time. Differential Manchester encoding is polarity-independent.
- 1.3.23 elastic buffer:** A variable delay element inserted in the ring by the active monitor to ensure that ring latency remains constant when the cumulative latency changes.
- 1.3.24 fill:** A sequence of data symbols of any combination of 0 and 1 data bits (as opposed to non-data-J and non-data-K bits) whose primary purpose is to maintain timing and spacing between frames and tokens.
- 1.3.25 frame:** A transmission unit that carries a protocol data unit (PDU) on the ring.
- 1.3.26 jitter:** The time varying phase of a pulse train relative to the phase of a reference pulse train. For the specifications in this document, jitter is usually measured as the difference in edge times of the receiver's recovered clock or transmitter data output to a reference clock or data signal, typically the preceding station's transmitter clock or data output. The specifications are measured in nanoseconds.
- 1.3.27 insertion loss:** The signal loss that results when a channel is inserted between a transmitter and a receiver, which is the ratio of the signal level delivered to a receiver before a channel is inserted to the signal level after the channel is inserted.

**1.3.28 latency:** The time, expressed in number of symbols, it takes for a signal to pass through a ring component. See **ring latency**; **cumulative latency**.

**1.3.29 LLC frame:** A token ring frame containing an LLC PDU exchanged between peer entities using the MAC services.

**1.3.30 lobe cabling:** The cabling used to interconnect the station MICs to the TCUs. This cabling includes all work area cabling, horizontal cabling, and patch cables. The lobe cable only carries ring signals when the station is actively connected on the ring (inserted). When the station is not inserted in the ring, the lobe cable may contain local test signals.

**1.3.31 Logical Link Control (sublayer) (LLC):** That part of the Data Link layer that supports media-independent data link functions and uses the services of the MAC to provide services to the network layer.

**1.3.32 MAC frame:** A token ring frame containing a MAC PDU exchanged between MAC entities used to convey information that is used by the MAC protocol or management of the MAC sublayer.

**1.3.33 main ring path:** Principal transmission path in the trunk cabling. The main ring path carries the data in the primary direction. (*Contrast with: backup path.*)

**1.3.34 medium:** The material on which the data may be transmitted. STP, UTP, and optical fibers are examples of media.

**1.3.35 Medium Access Control (sublayer) (MAC):** The portion of the data station that controls and mediates the access to the ring.

**1.3.36 medium interface connector (MIC):** A connector interface at which signal transmit and receive characteristics are specified for attaching stations and concentrators. One class of MICs is the connection between the attaching stations and the lobe cabling. A second set is the attachment interface between the concentrator and its lobes. A third set is the interface between the concentrator and the trunk cabling. Two types of connectors are specified: one for connecting to STP media and one for connecting to UTP media.

**1.3.37 monitor functions:** The functions that recover from various error situations and are contained in each ring station. In normal operation only one of the stations on a ring is the active monitor at any point in time. The monitor functions in all other stations on the ring ensures that the active monitor function is being performed.

**1.3.38 multiple frame transmission:** A transmission where more than one frame is transmitted when a token is captured.

**1.3.39 near end crosstalk (NEXT):** Near end crosstalk is crosstalk that is propagated in a distributed channel in the direction opposite to the direction of the propagation of the signal in the disturbing channel and is measured at or near the source of the disturbing signal.

**1.3.40 passive concentrator:** A type of token ring concentrator that contains no active elements in the signal path of any lobe port. Embedded repeater functions may be provided by the ring in and ring out port.

**1.3.41 Physical (layer) (PHY):** The layer responsible for interfacing with the transmission medium. This includes conditioning signals received from the MAC for transmitting to the medium and processing signals received from the medium for sending to the MAC.

**1.3.42 physical media components (PMC):** The sublayer of the PHY responsible for interfacing with the transmission medium. The functions of the PMC include receive, transmit, clock recovery, and ring access control.

**1.3.43 physical signaling components (PSC):** The sublayer of the PHY responsible for processing the signal elements received from the ring by the PMC for sending symbols to the MAC and for conditioning the symbols received from the MAC for inclusion as signal elements in the repeated data stream to the PMC.

**1.3.44 port:** A signal interface provided by token ring stations, passive concentrator lobes, active concentrator lobes, or concentrator trunks that is generally terminated at a media interface connector (MIC). Ports may or may not provide physical containment of channels.

**1.3.45 protocol data unit (PDU):** Information delivered as a unit between peer entities that contains control information and, optionally, data.

**1.3.46 protocol implementation conformance statement (PICS):** A statement of which capabilities and options have been implemented for a given Open Systems Interconnection (OSI) protocol.

**1.3.47 purging:** A ring state that occurs when the active monitor has detected a ring error and is returning the ring to an operational state by transmitting purge frames.

**1.3.48 recovery:** The process of restoring the ring to normal operation. When the ring is beaconing, claiming, or purging, the ring is in a state of recovery.

**1.3.49 repeat:** The action of receiving a bit stream (for example, frame, token, or fill) and placing it on the medium. Stations repeating the bit stream may copy it into a buffer or modify control bits as appropriate.

**1.3.50 repeater:** Physical layer coupler of ring segments. Provides for physical containment of channels, dividing the ring into segments. A repeater can receive any valid token ring signal and retransmit it with the same characteristics and levels as a transmitting station.

**1.3.51 ring error monitor (REM):** A function that collects ring error data from ring stations. The REM may log the received errors, or it may analyze this data and record statistics on the errors.

**1.3.52 ring in:** A port that receives signals from the main ring path on the trunk cable and transmits signals to the backup path on the trunk cable, and provides connectivity to the immediate upstream ring out port.

**1.3.53 ring latency:** In a token ring, the time (measured in bit times) it takes for a signal to propagate once around the ring. The ring latency time includes the signal propagation delay through the ring medium plus the sum of the propagation delays through each station or other element in the data path connected to the token ring.

**1.3.54 ring out:** A port that transmits the output signals to the main ring path on the trunk cable and receives from the backup ring path on the trunk cable, and provides connectivity to the immediate downstream ring in port.

**1.3.55 ring parameter server (RPS):** A function that is responsible for initializing a set of operational parameters in ring stations on a particular ring.

**1.3.56 ring segment:** Section of transmission path bounded by repeaters or converters. Ring segment boundaries are critical for determining the transmission limits that apply to the devices within the segment.

**1.3.57 routing information:** A field, carried in a frame, used by source routing transparent bridges that provides source routing operation in a bridged LAN.

**1.3.58 service data unit (SDU):** Information delivered as a unit between adjacent entities that may also contain a PDU of the upper layer.

**1.3.59 signal element:** A signal element is the logical signal value during one half of a bit time and may take on the values of Logic\_1 or Logic\_0.

**1.3.60 shielded twisted pair (STP):** Normally refers to those shielded cables with individual pairs of conductors twisted, or with a group of four conductors in a quad configuration, with any characteristic impedance. When used in this document, the term specifically refers to those shielded cables whose pairs have a high-frequency characteristic impedance of 150 W and with two pair of conductors shielded from any other individual pairs.

**1.3.61 source routing:** A mechanism to route frames through a bridged LAN. Within the source routed frame, the station specifies the route that the frame will traverse.

**1.3.62 standby monitor:** A station on the ring that is not in active monitor mode. The function of the standby monitor in normal ring operation is to assure that an active monitor is operating.

**1.3.63 station (or data station):** A physical device that may be attached to a shared medium LAN for the purpose of transmitting and receiving information on that shared medium. A data station is identified by a destination address (DA).

**1.3.64 static timing error:** The constant part of the difference in time between the ideal sampling point for the received data and the actual sampling point.

**1.3.65 station management (SMT):** The conceptual control element of a station that interfaces with all of the layers of the station and is responsible for the setting and resetting of control parameters, obtaining reports of error conditions, and determining if the station should be connected to or disconnected from the medium.

**1.3.66 stripping:** The action of a station removing the frames it has transmitted from the ring.

**1.3.67 symbol:** In this standard a symbol consists of two signal elements. Four symbols are defined: data\_zero, data\_one, non-data\_J, and non-data\_K.

**1.3.68 token:** A signal sequence passed from station to station that is used to control access to the medium.

**1.3.69 tracking error:** The portion of alignment error due to failure to track receiver jitter.

**1.3.70 transferred jitter:** The amount of jitter in the recovered clock of the upstream PHY which is subsequently transferred to the downstream PHY which in turn is transferred to the next downstream PHY. Transferred jitter is important because each PHY must both limit the amount of jitter it generates and track the jitter delivered by the upstream PHY.

**1.3.71 transmit:** The action of a station generating a frame, token, abort sequence, or fill and placing it on the medium. *Contrast with: repeat.*

**1.3.72 transparent bridging:** A bridging mechanism in a bridged LAN that is transparent to the end stations.

**1.3.73 trunk cable:** The transmission medium for interconnection of concentrators providing a main signal path and a back-up signal path, exclusive of the lobe cabling.

**1.3.74 trunk coupling unit (TCU):** A device that couples a station to the main ring path. A TCU provides the mechanism for insertion of a station into the ring and removal of it from the ring.

**1.3.75 uncorrelated jitter:** The portion of the total jitter that is independent of the data pattern. This jitter is generally caused by noise that is uncorrelated among stations and therefore grows in a non-systematic way along the ring. Uncorrelated jitter is also called *noise jitter* or *non-systematic jitter*.

**1.3.76 upstream neighbor's address (UNA):** The address of the station functioning upstream from a specific station.

**1.3.77 unshielded twisted pair (UTP):** Normally refers to those cables with individual pairs of conductors twisted, or with a group of four conductors in a star quad configuration, with any characteristic impedance. When used in this document, the term specifically refers to those cables whose pairs have a high-frequency characteristic impedance of 100  $\Omega$ . Shielded cables with the same high-frequency characteristic impedance are included within this definition.

**1.3.78 verified frame:** A valid frame as defined in 4.3.2, addressed to the station, for which the information field has met the validity requirements as specified in 3.3.5.2.

## 1.4 Conventions

When used in this standard, the term *reserved* shall be understood to mean *reserved for future standardization*. Use of reserved values to implement functions not covered by the standard may lead to interoperability problems and therefore is not recommended.

## 1.5 Abbreviations and acronyms

NOTE—All acronyms and notations used in state machine descriptions are summarized in 4.2.3 and 4.3.5.

A bit	=	address-recognized bit
AC	=	access control (field)
ACR	=	attenuation to crosstalk ratio
AD	=	abort delimiter
AJ	=	accumulated jitter
AUJA	=	accumulated uncorrelated jitter alignment
AMP	=	active monitor present
APS	=	accumulated phase slope
ARC	=	active retiming concentrator
BER	=	bit error rate
BN	=	beacon
C bit	=	frame-copied bit
CATT	=	concentrator maximum flat attenuation
CMIC	=	concentrator medium interface connector
CRS	=	configuration report server
CSQA	=	concentrator square-root-frequency attenuation
CT	=	claim token
DA	=	destination address
DAT	=	duplicate address test
DC	=	destination class
DFAPS	=	delta filtered accumulated phase slope
E bit	=	error-detected bit
ED	=	ending delimiter

EFS	=	end-of-frame sequence
ETR	=	early token release
FA	=	functional address
FAJ	=	filtered accumulated jitter
FAI	=	functional address indicator
FAPS	=	filtered accumulated phase slope
FC	=	frame control (field)
FCS	=	frame-check sequence
FR	=	frame
FS	=	frame status (field)
FSM	=	finite state machine
HFEJ	=	high-frequency edge jitter
I bit	=	intermediate frame bit
IFG	=	interframe gap
INIT	=	initialization
ISI	=	inter-symbol interference
JTOL	=	jitter tolerance
JTOLX	=	jitter tolerance in the presence of crosstalk
LAN	=	local area network
LLC	=	logical link control (sublayer)
LTH bit	=	length bit
M bit	=	monitor bit
MA	=	my (station's) address
MAC	=	Medium Access Control (sublayer)
MGT	=	management
MIC	=	medium interface connector
MIC_S	=	shielded twisted pair MIC
MIC_U	=	unshielded twisted pair MIC
nFAPS	=	normalized filtered accumulated phase slope
NDT	=	net delay time
NEXT	=	near end crosstalk
NIR	=	NEXT loss to insertion loss ratio
NN	=	neighbor notification
OSI	=	Open Systems Interconnection
PDU	=	protocol data unit
PHY	=	Physical (Layer)
PICS	=	protocol implementation conformance statement
PLL	=	phase locked loop
Pm	=	priority of queued PDU
Pr	=	last priority value received
PMC	=	physical media components
P	=	priority bits (of the access control field)
PSC	=	physical signaling components
Px	=	the greater value of Pm or Rr
R	=	reservation bits (of the access control field)
RAC	=	ring access control
RI	=	routing information (a field in the frame format)
RI	=	ring in (trunk in port on a concentrator)
RIMIC	=	ring in MIC
RII	=	routing information indicator
REM	=	ring error monitor
RO	=	ring out (trunk out port on a concentrator)
ROMIC	=	ring out MIC
RP	=	ring purge

RPS	=	ring parameter server
RPT	=	repeat
RQ	=	request
Rr	=	last reservation value received
RRL	=	receiver return loss
RS	=	ring station
RUA	=	reporting station's upstream neighbor's address
RX	=	receive
SA	=	source address
SC	=	source class
SCNR	=	signal to crosstalk noise ratio
SD	=	starting delimiter
SDU	=	service data unit
SFS	=	start-of-frame sequence
SIR	=	signal to interference ratio
SMP	=	standby monitor present
Sr	=	highest stacked received priority
SRT	=	source routing transparent
STP	=	shielded twisted pair
SUA	=	stored upstream neighbor's address
SV	=	subvector
SVI	=	subvector identifier
SVL	=	subvector length
SVV	=	subvector value
Sx	=	highest stacked transmitted priority
TAM	=	timer, active monitor
TBR	=	timer, BN receive
TBT	=	timer, BN transmit
TCATT	=	total channel attenuation
TCT	=	timer, claim token
TCU	=	trunk coupling unit
TDCD	=	transmitter duty cycle distortion
TDOV	=	transmitter differential output voltage
TER	=	timer, error report
TID	=	timer, insert delay
TJR	=	timer, join ring
TK	=	token
TNT	=	timer, no token
TQP	=	timer, queue PDU
TRI	=	timer, ring initialization
TRH	=	timer, remove hold
TRP	=	timer, transmit ring purge
TRR	=	timer, return to repeat
TRW	=	timer, remove wait
TSL	=	timer, signal loss
TSM	=	timer, standby monitor
TVX	=	timer, valid transmission
TWF	=	timer, wire fault
TWFD	=	timer, wire fault delay
TX	=	transmit
TXRL	=	transmit return loss
UNA	=	upstream neighbor's address
UTP	=	unshielded twisted pair
VC	=	vector class

VI = vector identifier  
VL = vector length

## 1.6 Conformance requirements—station

The supplier of a protocol implementation that is claimed to conform to this standard shall complete a copy of the PICS proforma in annex A and shall provide the information necessary to identify both the supplier and the implementation.

### 1.6.1 Static conformance requirements

#### 1.6.1.1 MAC sublayer

An implementation claiming conformance to this standard shall

- a) Implement the token format, the frame format, associated address formats and fields, and MAC frame vectors and subvectors as defined in 3.1, 3.2, and 3.3.
- b) Support 48-bit addressing and use either a universally administered individual address or a locally administered individual address.
- c) Exhibit external behavior corresponding to the timer system timing parameters as specified in 3.4.
- d) Exhibit external behavior corresponding to the station policy flags as specified in 3.5.
- e) Implement capabilities corresponding to the counters as defined in 3.6.
- f) Recognize the first bit of the source address as the indication of the presence of the routing information field in the frame format. Note that the ability to generate or respond to frames with source routing information is optional.

#### 1.6.1.2 PHY layer

An implementation claiming conformance to this standard shall

- a) Use a data signaling rate at 4 Mbit/s or 16 Mbit/s as defined in 5.2. Implementations may support either or both data rates.
- b) Encode and decode symbols as defined in 5.4 and 5.6.
- c) Achieve signal timing synchronization as defined in 5.7.
- d) Add latency as defined in 5.8.
- e) Meet multiple station accumulated jitter requirements defined in 7.1.
- f) Support either STP or UTP cabling at the MIC as defined in 7.2. Implementations may support either or both media types using the appropriate MIC connector (MIC\_S for STP and MIC\_U for UTP).
- g) Provide phantom signaling and wire fault detection as defined in 7.2.1.
- h) Meet transmit specifications as defined in 7.2.2.
- i) Meet receiver jitter tolerance specifications as defined in 7.2.3.
- j) Operate with the channels specified in 7.2.4.

### 1.6.2 Dynamic conformance requirements

An implementation claiming conformance to this standard shall perform the following actions:

- a) Receive MAC and LLC frames and perform the actions defined in 4.3.

- b) Receive and utilize tokens for the transmission of queued PDUs as defined in 4.3.
- c) Transmit queued PDUs as frames as defined in 4.3.
- d) Strip frames transmitted by the station as defined in 4.3.
- e) Transmit tokens in accordance with 4.3 after a frame(s) has been transmitted.
- f) Perform priority operation as defined in 4.3.
- g) Queue DAT\_PDU, AMP\_PDU, SMP\_PDU, and RQ\_INIT\_PDU as defined in 4.3.
- h) Autonomously transmit fill and the Ring Purge, Claim Token, and Beacon frames as defined in 4.3.
- i) Enter BYPASS as defined in 4.3.
- j) Assume ACTIVE MONITOR STATE as defined in 4.3.
- k) Assume STANDBY MONITOR STATE as defined in 4.3.

## 1.7 Conformance requirements—concentrator

The supplier of a protocol implementation which is claimed to conform to this standard shall complete a copy of the PICS proforma in annex A and shall provide the information necessary to identify both the supplier and the implementation.

### 1.7.1 Static conformance requirements

- a) Support a data signaling rate at 4 Mbit/s or 16 Mbit/s as defined in 5.2. Implementations may support either or both data rates.
- b) Support either STP or UTP cabling at the MIC as defined in 8.1.1 for the lobe connector. Implementations may support either or both medium types using the appropriate MIC connector (MIC\_S for STP and MIC\_U for UTP).
- c) Support either STP or UTP cabling at the MIC as defined in 8.1.1 for the trunk connector. Implementations may support either or both media types using the appropriate MIC connector (MIC\_S for STP and MIC\_U for UTP).
- d) Provide the RAC function specified in 8.3 for the lobe connectors. This RAC function is complementary to the station phantom signaling and wire fault detection as defined in 7.2.1.
- e) Support either a passive concentrator function or an active retimed concentrator function. For a passive concentrator function, the signal attenuation and crosstalk parameters are specified in 8.4. For an active retimed concentrator function, the parameters are specified in 8.5. The active retimed concentrator function parameters are closely related to the station PHY function parameters defined in 7.2.1 through 7.2.4.

## 1.8 Local regulations

The supplier of a protocol implementation that is claimed to conform to this standard should meet local safety and environmental regulations. Annex E provides some limited guidance in this area.

## 2. General description

### 2.1 Architectural view

There are two important ways to view local area network design: architectural, which emphasizes the logical divisions of the system and how they fit together; and implementational, which emphasizes the actual components, their packaging, and their interconnection.

This standard presents the architectural view, emphasizing the large-scale separation of the system into two parts: the MAC of the Data Link layer and the PHY. These layers are intended to correspond closely to the lowest layers of the ISO Basic Reference Model (ISO/IEC 7498-1 : 1994). As shown in figure 1, the LLC and MAC together encompass the functions intended for the data link layer of the OSI model. The MAC to LLC service definition is specified in ISO/IEC 15802-1 : 1995.

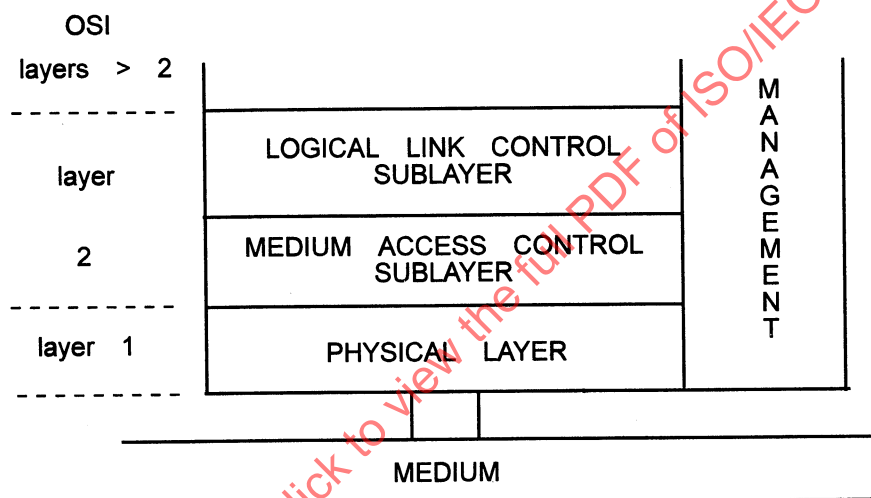

Figure 1—Relation of OSI Reference Model to the LAN Model

An architectural organization of the standard has the advantages of clarity (a clean overall division of the design along architectural lines makes the standard clearer) and flexibility (segregation of the access-method-dependent aspects of the MAC and PHY allows the LLC to apply to a variety of LAN access methods).

The exact relationship of the layers described in this standard to the layers defined by the OSI Reference Model is a subject for further study.

### 2.2 Station functional organization and data flow

Figure 2 is an illustration of a station's data flow indicating which clauses of this standard address the various functions of a token ring station. The operation of a station is specified in clauses 3 through 7, and operation of the concentrator is specified in clause 8. Internal service interfaces have been defined solely for the purpose of specifying operation between the clauses and are not requirements for a physical interface.

- a) The PMC/PSC internal service interface (PM\_UNITDATA.request; PM\_UNITDATA.indication) defines the information exchange between the physical media components (PHY) specified in clause 7 and the physical signaling components (PSC) specified in clause 5. This service interface is defined in clause 5.
- b) The PSC/MAC internal service interface (PS\_CONTROL.request, PS\_STATUS.indication, PS\_UNITDATA.indication, PS\_UNITDATA.request, PS\_EVENT.response) defines the control mechanism of, the mechanism for indicating the status of, and the information exchange between, the physical signaling components (PSC) specified in clause 5 and the MAC sublayer specified in clauses 3 and 4. Clause 3 defines frame formats and station facilities. Clause 4 specifies the MAC protocol that uses the formats and facilities defined in clause 3 to receive and transmit information. This service interface is defined in clause 5.
- c) The MAC/PHY internal service interface (PM\_CONTROL.request and PM\_STATUS.indication) provides the control mechanism of the PHY functions by the MAC protocol, and the mechanism for indicating the status of the PHY functions to the MAC protocol. This service interface is defined in clause 5.
- d) The MAC/LLC service interface (MA\_UNITDATA.indication, MA\_UNITDATA.request) is specified in ISO/IEC 15802-1 and defines the information exchange between the MAC sublayer and the LLC sublayer.
- e) The MAC/Bridge service interface (M\_UNITDATA.indication, M\_UNITDATA.request, M\_UNITDATA.response) is specified in ISO/IEC 10038 : 1993 and defines the information exchange between the MAC and the internal bridging sublayer.
- f) The MAC/MGT service interface (MGT\_UNITDATA.indication, MGT\_UNITDATA.request, MGT\_CONTROL.request, MGT\_STATUS.indication) defines the control mechanism of, the mechanism for indicating the status of, and the information exchange between, the MAC protocol specified in clause 4 and management (MGT). The managed objects are specified in clause 6. The MGT\_UNITDATA.indication and MGT\_UNITDATA.request primitives are specified in clause 4 and are used to convey MAC management frames between the MAC and the appropriate management function (e.g., RPS, CRS, REM).

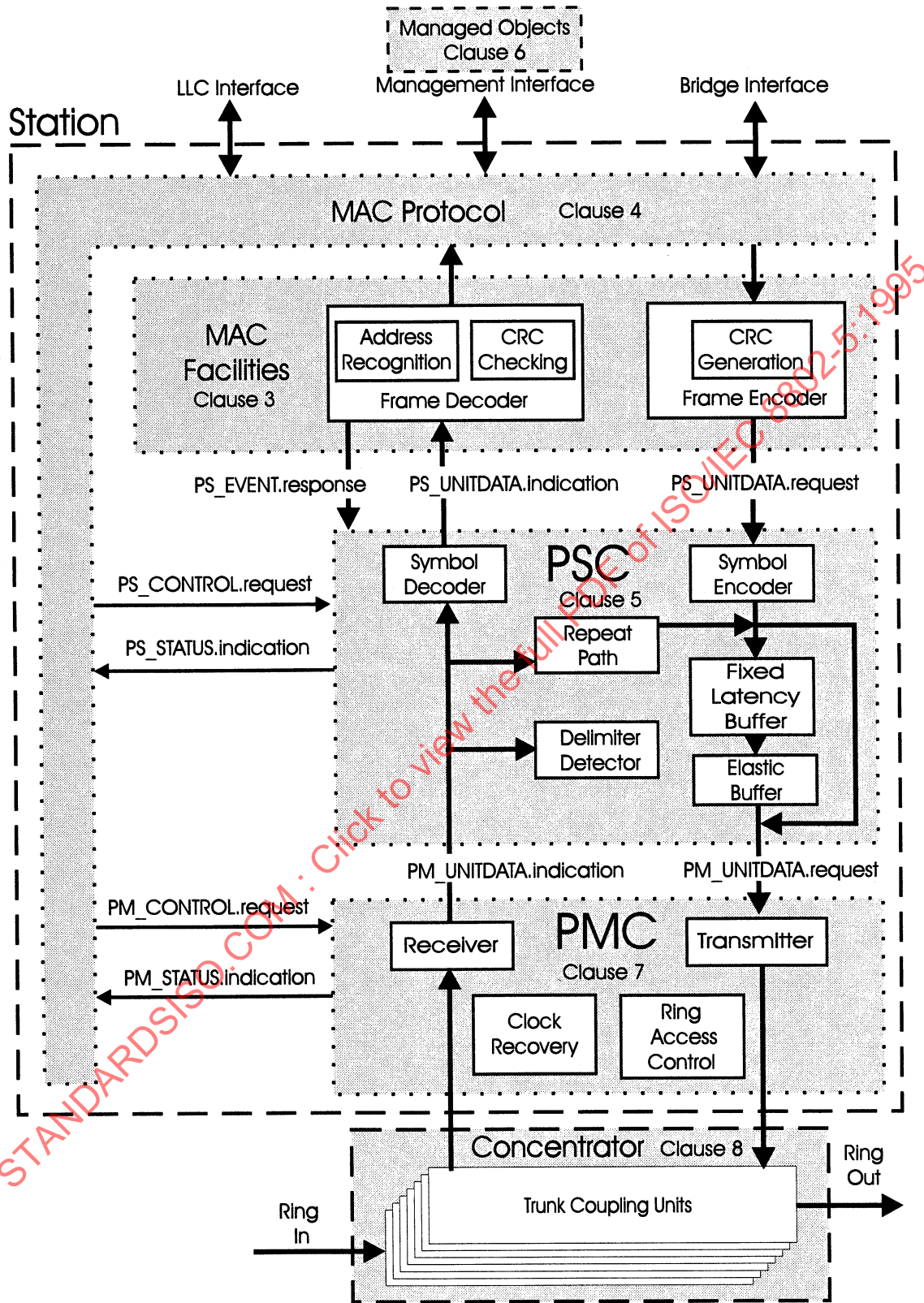

Figure 2—Station functional organization and data flow

### 2.3 Physical structure of a token ring network

A token ring consists of a star wired system of stations with each station connected by a lobe cable to a concentrator TCU, as shown in figure 2. A concentrator contains multiple TCUs. Concentrators are serially interconnected using the concentrator ring in and ring out ports, forming the main ring path and the back-up ring path. Interconnection on the main ring and back-up ring paths may include the use of repeaters and converters that divide the total signal path into separate segments to bound the total channel path length for each station.

Networks may include repeaters and/or converters at each trunk interface where the transmission medium is changed, i.e., between STP and fiber, between STP and UTP, between UTP and fiber. Thus, each of these interfaces becomes a ring segment boundary. Evaluation and control of jitter buildup across these segments is a subject for future study.

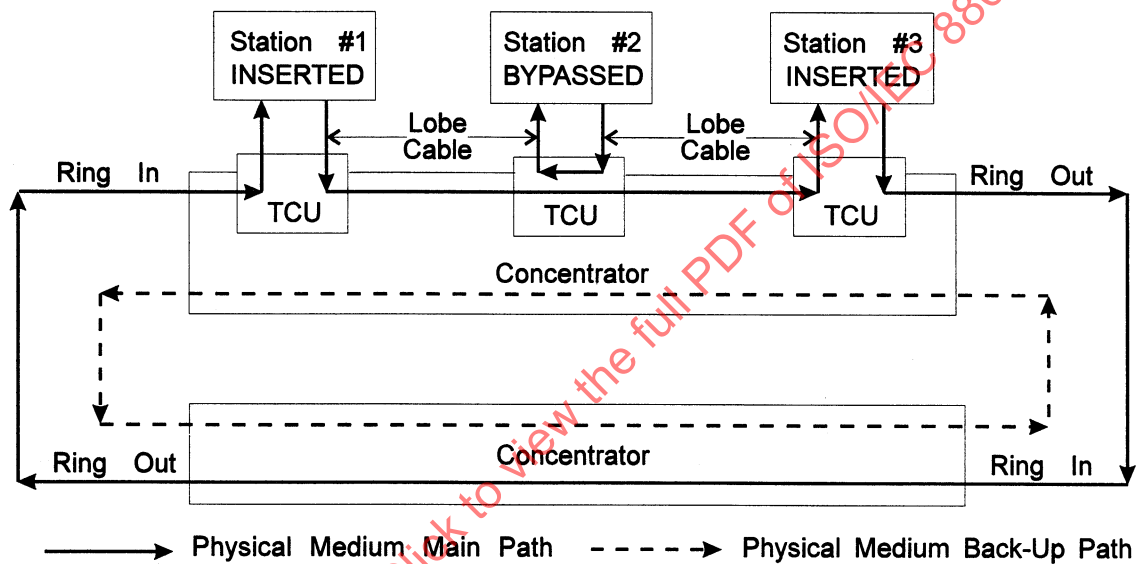

Figure 3—Typical token ring wiring example

Each TCU provides attachment (“insertion” or “bypass”) of the station into or from the trunk ring. This insertion/bypass mechanism is usually controlled by the attaching station’s ring access control (RAC) function. A station performs self-tests of the attached cable lobe and the station’s MAC and PHY layer circuitry by operating a one-node network while the TCU function is in the bypass mode (e.g., Station #2 in figure 3.) When the TCU receives a dc signal from the station via the lobe cable, the TCU switches from bypass mode to inserted mode, allowing the inserting station’s MAC to receive a symbol stream from its upstream neighbor, and provide an output symbol stream to its downstream neighbor.

The maximum station count on a single token ring is limited by both MAC and PHY considerations. If the recommended system timing parameters (see 3.4) are used, operation of up to 250 stations on the ring is possible. Modifications of this station count may occur based on media type, data rate, use of repeaters or converters, and concentrator type.

Information on the token ring is transferred sequentially, bit by bit, from one inserted station to the next. In figure 3, Station #1 would transmit to Station #3 and Station #3 would transmit to Station #1. Each station generally regenerates and repeats each bit and serves as the means for attaching one or more devices (terminals, work stations) to the ring for the purpose of communicating with other devices on the network.

A given station transfers information onto the ring, where the information circulates from one station to the next. The addressed destination station(s) copies the information as it passes. Finally, the station that transmitted the information strips the information from the ring.

A station gains the right to transmit its information onto the medium when it detects a token passing on the medium. The token is a control signal comprised of a unique signaling sequence that circulates on the medium following each information transfer. Any station, upon detection of an appropriate token, may capture the token by modifying it to a start of frame sequence and appending appropriate control and status fields, address fields, routing information field, information field, check sum, and the ending frame sequence. At the completion of its information transfer and after appropriate checking for proper operation, the station initiates a new token, which provides other stations the opportunity to gain access to the ring.

The maximum period of time a station may transmit on the medium before releasing the token is controlled by counter CTO (used as a timer).

Multiple levels of priority are available for independent and dynamic assignment depending upon the relative class of service required for any given message; for example, real-time voice, interactive, immediate (network recovery). The allocation of priorities is by mutual agreement among users of the network.

Error detection and recovery mechanisms are provided to restore network operation in the event that transmission errors or medium transients (for example, those resulting from station insertion or removal) cause the access method to deviate from normal operation. Detection and recovery for these cases utilize a network monitoring function that is performed in a specific station (the active monitor), with back-up capability in all other stations that are attached to the ring (standby monitors).

## 2.4 Data stations, servers, and system management

Each ring in a token ring network may have a set of server stations (servers) that provide a means through which a system manager manages the stations in a token ring system. Such arrangement is depicted in figure 4.

Servers are data collection points on each ring where reports from the data stations are gathered. Servers then communicate the necessary information to the system manager for the purpose of managing a token ring system.

Data stations communicate with the servers by

- a) Reporting errors that are detected, such as lost token, FCS error, or lost frames;
- b) Requesting operating parameters when inserting into the ring;
- c) Reporting changes in configuration due to insertion or removal of stations (UNA changes);
- d) Responding to requests for various status information; and
- e) Removing from the ring when requested.

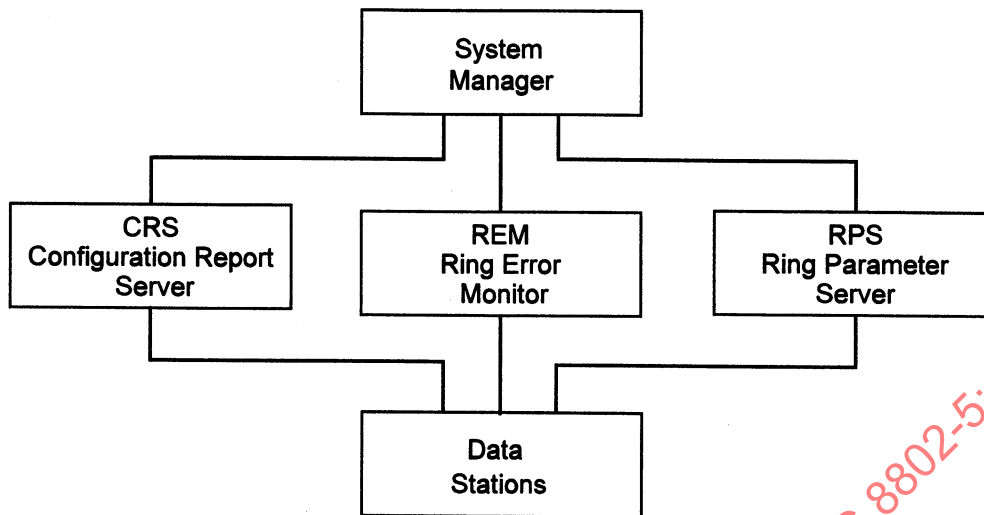

**Figure 4—Relationship of data stations, servers, and system manager**

The station-to-server message format and content is specified in clause 3; the protocol for message exchange is specified in clause 4.

The RPS sets MAC entity parameters and can limit access to the ring. It does this by responding to the Request Initialization MAC frame with an Initialize Station MAC frame.

The CRS receives management information about the current status and configuration of the ring, and may issue MAC frames to stations on the ring in response to a request from a management entity.

The REM receives from MAC entities, and reports to the requester, error statistics regarding ring and station operation.

Specification of the operation of the RPS, CRS, and REM is beyond the scope of this standard.

The specification of the format and protocol for the information interchange between the servers and the systems manager is not covered by this standard. However, the objects (parameters, events, and actions) specified in clause 6 are the elements of such communication.

A source routing station may send and receive frames that include a routing information field as specified in ISO/IEC 10038 : 1993. The routing information field may be determined through the use of protocols specified in ISO/IEC 8802-2 : 1994. A station that does not support the source routing information field is prohibited from setting the RII bit (first bit in the source address field).

A source routing transparent bridge copies frames based on the routing information field as well as the destination address as specified in ISO/IEC 10038 : 1993. A source routing transparent bridge may set the address-recognized bits in a frame that it copies with intent to forward. Otherwise, stations are prohibited from setting the address-recognized bits unless the frame is addressed to the station's individual address or to a group address for which the station is enabled.

### 3. Formats and facilities

This clause defines token ring formats (3.1), token and frame field descriptions (3.2), MAC frames (3.3), system timing parameters (3.4), station policies (3.5), and error counters (3.6).

The figures depict the formats of the fields *in the sequence they are transmitted on the medium*, with the left-most bit or symbol transmitted first.

Processes that require comparison of fields or bits perform that comparison upon those fields or bits *as depicted*, with the left-most bit or symbol compared first and, for the purpose of comparison, considered most significant.

Binary values are represented by the binary digits 0, 1, or x, which are enclosed by B' and '. The lowercase x represents a digit that may be 0 or 1. An example of a binary notation is B'001x'.

Hexadecimal values are represented by hexadecimal digits 0-9, A-F, or x, which are enclosed by X' and '. The lowercase x represents a digit that may be any hexadecimal value. An example of a hexadecimal notation is X'01 6F'.

All values are stated most significant digit first. Spaces within a value are for clarity and may be ignored.

#### 3.1 Formats

The symbol sequences used in token ring are the token, frame, abort sequence, and fill.

##### 3.1.1 Token format

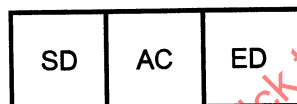

SD = Starting Delimiter (1 octet)  
AC = Access Control (1 octet)  
ED = Ending Delimiter (1 octet)

Error (E-bit) coverage is the AC field

Figure 5—Token format

The token is the means by which the right to transmit (as opposed to the normal process of repeating) is passed from one station to another. The token may occur anywhere in the data stream; that is, receiving stations shall be able to detect a token on any signal element boundary.

Error checking of token formats is defined in 3.2.8.2, and validity requirements are specified in 4.3.1.

**3.1.2 Frame format**

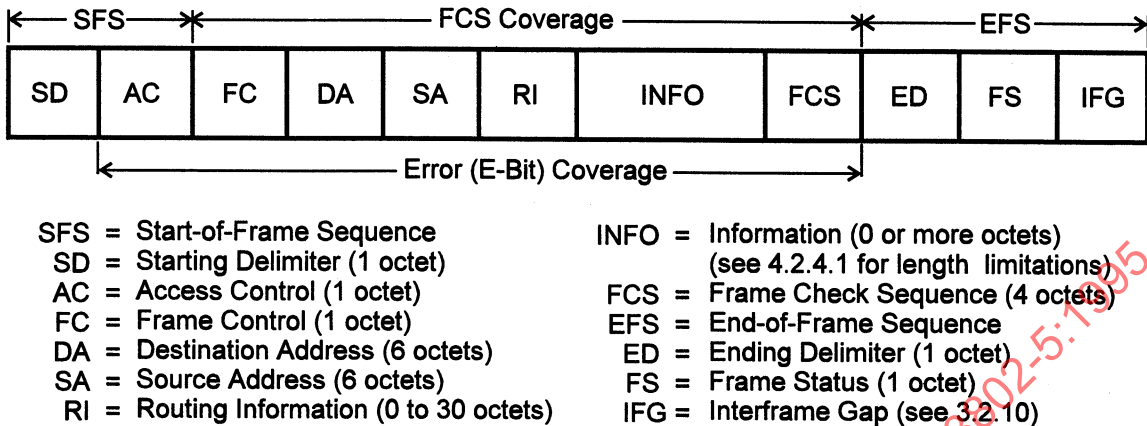
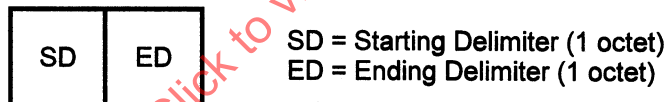

**Figure 6—Frame format**

The frame format shall be used for transmitting both MAC and LLC messages to the destination station(s). It may or may not contain an information (INFO) field. It may or may not contain a routing information (RI) field (see 3.3.5.1 regarding restrictions in certain MAC frames). The frame format may occur anywhere in the data stream; that is, receiving stations shall be able to detect a frame on any signal element boundary.

Error checking of frame formats is defined in 3.2.8.2 and validity requirements are specified in 4.3.2.

**3.1.3 Abort sequence**



**Figure 7—Abort sequence**

The abort sequence is transmitted by a station when an error condition causes the station to prematurely terminate the transmission of a frame. The abort sequence causes stations receiving the frame to recognize that it is not a valid frame. The abort sequence may occur anywhere in the data stream; that is, receiving stations shall be able to detect an abort sequence on any signal element boundary.

**3.1.4 Fill**

A station shall transmit fill as any combination of Data\_zero and Data\_one symbols in accordance with the protocol described in clause 4.

**3.2 Field descriptions**

The following is a detailed description of the individual fields used for the abort sequence, token, and frame formats.

### 3.2.1 Starting delimiter (SD) field

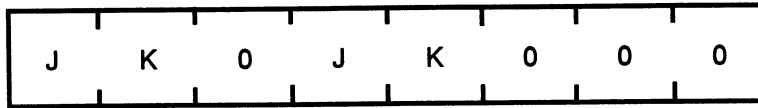

J = Non-data\_J symbol  
K = Non-data\_K symbol  
0 = Data\_zero symbol

(For a discussion of non-data symbols, see 5.3.)

Figure 8—Starting delimiter field

A frame, token, or abort sequence always starts with a starting delimiter. Receiving stations shall consider the SD valid only if all eight symbols of the SD (J K 0 J K 0 0 0) are received correctly.

### 3.2.2 Access control (AC) field

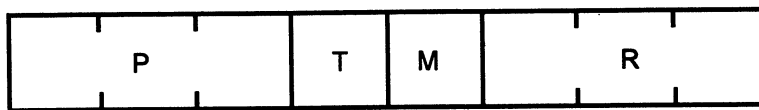

P = priority bits  
T = token bit  
M = monitor bit  
R = reservation bits

Figure 9—Access control field

#### 3.2.2.1 Priority bits

The priority bits indicate the priority of a token and, therefore, when stations are allowed to use the token. Frames carry the same access priority as the token used to gain access. In a multiple-priority system, the priorities of tokens that a station uses depend on the priority of the PDU to be transmitted. The eight levels of priority increase from the lowest (B'000') to the highest (B'111') priority.

#### 3.2.2.2 Token bit

The token bit is a 0 in a token and a 1 in a frame. When a station with a PDU to transmit detects a token that has a priority equal to or less than the PDU to be transmitted, it may change the token to a SFS and transmit the PDU.

#### 3.2.2.3 Monitor (M) bit

The M bit is used to prevent a token that has a priority greater than B'000' or any frame from continuously circulating on the ring. All frames and tokens shall be transmitted with the M bit set to 0. As a token with priority greater than zero or any frame is being repeated by the active monitor, the M bit is set to 1. All other stations repeat this bit as received. If an active monitor detects a token or a frame with the M bit equal to 1, it initiates the ring purge process. During beaconing, the station downstream from the beaconing station will optionally assume this role of setting and inspecting the M bit.

#### 3.2.2.4 Reservation bits

The reservation bits allow stations with high priority PDUs to request (in frames or tokens as they are repeated) that the next token be issued at the requested priority. The precise protocol for setting these bits is described in clause 4. The eight levels of reservation increase from B'000' to B'111'.

### 3.2.3 Frame control (FC) field

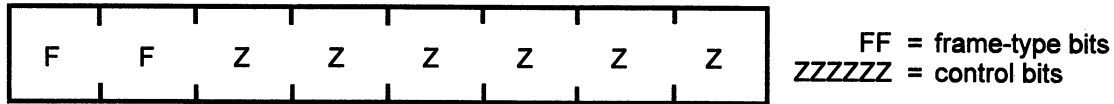

Figure 10—Frame control field

The FC field identifies the frame type and indicates MAC frame handling or LLC frame priority.

#### 3.2.3.1 Frame-type bits

The frame-type bits indicate the type of the frame as follows:

- a) B'00' = MAC frame (contains a MAC PDU)
- b) B'01' = LLC frame (contains an LLC PDU)
- c) B'1x' = undefined format (reserved for future standardization)

In this standard, the term MAC frame is defined as the type of frame used to convey information used by the MAC protocol or management of the MAC sublayer.

##### 3.2.3.1.1 Undefined frame format

The value B'1x' is reserved for frame types that may be defined in the future. However, although currently undefined, any future frame formats are required to adhere to the following conditions to ensure compatibility:

- a) The frame format shall be delimited by the SFS fields and the EFS fields. No additional fields may be included in or follow the EFS field.
- b) The position of the AC and FC field shall be unchanged.
- c) The SFS and EFS of the format shall be separated by an integral number of octets. This number shall be at least 1 (that is, the FC field) and the maximum length is subject to the constraints of the token holding time.
- d) All symbols between the SD and ED shall be Data\_zero and Data\_one symbols.

#### 3.2.3.2 ZZZZZZ bits

##### 3.2.3.2.1 MAC frames

If the frame-type bits indicate a MAC frame, the ZZZZZZ control bits specify MAC frame handling (see 3.3.1 and 3.3.5).

##### 3.2.3.2.2 LLC frames

If the frame-type bits indicate an LLC frame, the ZZZZZZ bits are designated as "rrrYYY". The "rrr" bits are reserved for future standardization and shall be transmitted as B'000' in all transmitted frames and may be ignored upon reception. The "YYY" bits may be used to carry the user priority of the PDU from the source LLC entity to the target LLC entity or entities. Note that P (the priority in the AC field of a frame) does not convey user priority.

### 3.2.3.2.3 Undefined frame format

The ZZZZZZ bits are undefined and reserved for future standardization.

### 3.2.4 Destination address (DA) and source address (SA) fields

Each frame contains two address fields: the destination (station) address and the source (station) address, in that order. Representation of addresses used in this standard are different than the representation utilized in ISO/IEC 15802-1 : 1995.

#### 3.2.4.1 Destination address (DA) field

The frame's DA identifies the station or stations for which the information field of the frame is intended. Included in the frame's DA are two bits that 1) indicate whether the DA is a group or individual address and 2) indicate whether the DA is a locally or universally administered address.

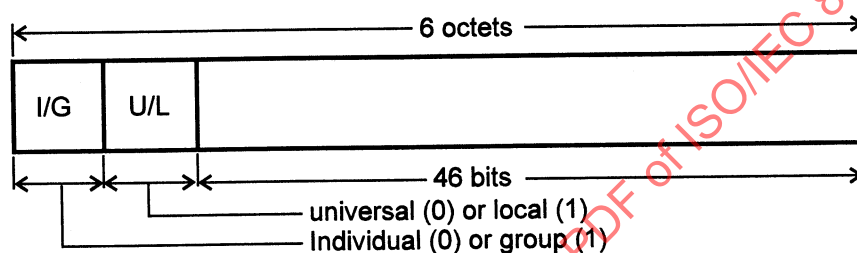

Figure 11—Destination address field

##### 3.2.4.1.1 Individual address

When the first bit of the frame's DA field is equal to a zero (0), the address is an individual address. An individual address identifies a particular station and must be distinct from all other individual station addresses on the same LAN (in the case of local administration) or from the individual addresses of other LAN stations on a global basis (in the case of universal administration).

##### 3.2.4.1.2 Group address

When the first bit of the frame's DA field is equal to a one (1), the address is a group address. A group address is used to address a frame to multiple destination stations. Group addresses may be associated with zero or more stations on a given LAN. In general, a group address is an address associated by convention with a group of logically related stations. It has been observed that several protocols in general usage today require support for one or more general group addresses, and that failure to provide station support for multiple group address recognition can be a serious impediment to use of that station in multi-protocol environments. It is recommended that stations support recognition of multiple general group addresses.

##### 3.2.4.1.3 Broadcast address

The group address X'FF FF FF FF FF FF' is defined as a broadcast address and denotes the set of all stations on a given LAN. X'C0 00 FF FF FF FF' is also a broadcast address for MAC frames. Note that this requirement generally places the address X'C0 00 FF FF FF FF' in the set of addresses recognized by the token ring station and therefore the use of X'C0 00 FF FF FF FF' for non-MAC frames should be avoided.

**3.2.4.1.4 Null address**

The individual address X'00 00 00 00 00 00' is defined as the null address. It indicates the frame is not addressed to any station. No station shall be assigned the null address and therefore frames addressed to the null address are not expected to be copied by the station.

**3.2.4.1.5 Functional addresses (FAs)**

FAs are contained within a subset of locally administered group addresses. They are bit-significant addresses used to identify well-known functional entities. There are 31 functional addresses that are indicated by the least significant 31 bits of the destination address when the most significant 17 bits indicate functional addressing. The functional address indicator (FAI) identifies an FA (versus a general group address) when the first 2 octets of the DA are X'C000' and the first bit of the third octet is B'0' (i.e., B'1100 0000 0000 0000 0'). The remaining 31 bits of the address field each represent a functional address.

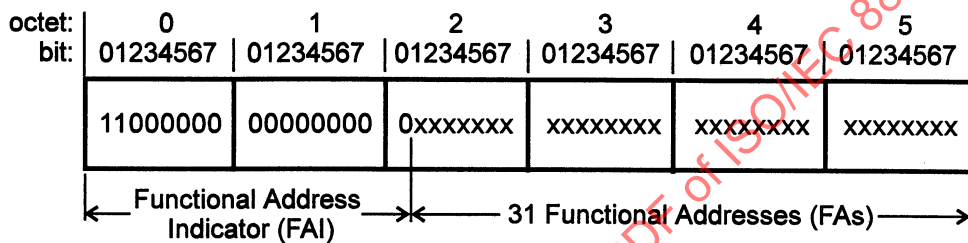

**Figure 12—Functional address format**

The following functional addresses are defined for use in MAC frames:

**Table 1—MAC functional address**

Functional address (FA)	Function name	6 octet address
B'xxx xxxx xxxx xxxx xxxx xxxx xxx1'	Active monitor	X'C0 00 00 00 00 01'
B'xxx xxxx xxxx xxxx xxxx xxxx xx1x'	Ring parameter server (RPS)	X'C0 00 00 00 00 02'
B'xxx xxxx xxxx xxxx xxxx xxxx 1xxx'	Ring error monitor (REM)	X'C0 00 00 00 00 08'
B'xxx xxxx xxxx xxxx xxxx xxx1 xxxx'	Configuration report server (CRS)	X'C0 00 00 00 00 10'

The 6 octet address in the table indicates the address for that single function. Multiple functions are addressed by combining the functional addresses. An example is X'C0 00 00 00 00 12' which is addressed to both the RPS and the CRS functions.

When a station “sets” a functional address, it will recognize all frames sent to that function by setting the A bits and attempting to copy all frames whose DA contains the FAI and has the corresponding FA bit set to B'1'. The active monitor functional address shall only be set as specified in 4.3.4. All other functional addresses are set by management.

Use of functional addresses, octet 5 bit 1 through octet 5 bit 7, that are not defined above are reserved. Functional addresses, octet 2 bit 1 through octet 5 bit 0, are available for general use.

Refer to ISO/IEC TR 11802-2: 1995 for locally administered MAC group (functional) addresses used by this part of ISO/IEC 8802. Also note that functional address X'CO 00 00 00 00 80' is widely used by higher layer protocols and that functional address X'CO 00 00 00 01 00' is widely used for bridging. Because a functional address may be used simultaneously by multiple protocols, a user cannot assume that it designates a single function. Other frame fields should be used to identify the destination function.

The MAC protocol depends on receiving a proper INITIALIZE STATION MAC frame when the RPS functional address is recognized by any station on the ring. The join ring process may not complete properly (e.g., fail joining the ring) if the RPS function does not function as expected (see 4.3.4, JS=RQI). Therefore, if a station does not perform the RPS function, it shall not recognize the RPS functional address and shall not set A or C bits in a frame addressed exclusively to the RPS functional address.

#### 3.2.4.1.6 Address administration

There are two methods of administering station addresses: locally or through a universal authority. The second bit transmitted of the DA indicates whether the address has been assigned by a universal or local administrator:

0 = universally administered

1 = locally administered

#### 3.2.4.1.7 Universal administration

With this method, all individual addresses are distinct from the individual addresses of all other LAN stations on a global basis. The procedure for administration of these addresses is not specified in this standard. Information concerning the registration authority and its procedures may be obtained on request from the Secretary General, ISO Central Secretariat, Case Postale 56, CH-1211 Genève, Switzerland. For information on global address administration contact the Registration Authority for ISO 8802-5, c/o The Institute of Electrical and Electronics Engineers, Inc., 445 Hoes Lane, P.O. Box 1331, Piscataway, NJ 08855-1331, USA.

#### 3.2.4.1.8 Local administration

Individual station addresses are administered by a local (to the LAN) authority. Network administrators should be careful when assigning locally administered addresses due to the structure of hierarchical addressing (defined in previous versions of this standard). The least significant 14 bits of the first two octets of the address have a special meaning (ring ID). Two values of ring ID are assigned for use with all stations (null ring—all zeros, and any ring—all ones). Because of this, the following sets of addresses should be used with care: X'40 00 xx xx xx xx', X'7F FF xx xx xx xx', X'CO 00 xx xx xx xx', X'FF FF xx xx xx xx' (where x is any hexadecimal value). When using locally administered addresses in these ranges, it is possible for the duplicate address test (DAT) to fail when another station is using an address that only differs by the first two octets. In addition, locally administered group addresses with the last 4 octets X'FF FF FF FF' may also be recognized by hierarchical addressing as a broadcast address. Note that the hierarchical addressing "ring ID" is not associated with the "local ring number" subvector.

Hierarchical addressing for locally administered addresses is not required nor specified by this standard. Future implementations are discouraged from implementing hierarchical addressing.

#### 3.2.4.2 Source address (SA) field

The frame's SA identifies the station originating the frame. In contrast to the DA field, no individual/group (I/G) bit is encoded in the SA since the SA is constrained to be an individual address. The implied value for the I/G is always 0. In its place is the routing information indicator (RII) bit used to indicate the presence or absence of a routing information (RI) field in the frame. If the RII bit is 0, then no RI field is

present, and if the RII bit is 1, then a RI field is present. The universal/local (U/L) bit still indicates whether the address is universally or locally administered, as in the DA.

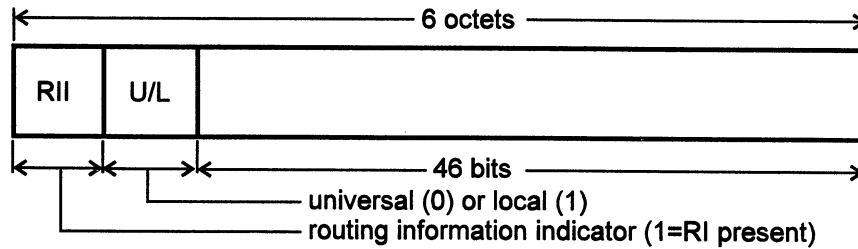

Figure 13—Source address field

### 3.2.5 Routing information (RI) field

When a frame's routing information indicator bit in the source address field is equal to 1 (RII=1), the RI field shall be included in the frame. The following provides sufficient information for the MAC entity to determine the size of the RI field and parse the frame properly. The detailed structure and contents for the RI field is described in ISO/IEC 10038 : 1993 and ISO/IEC 8802-2 : 1994.

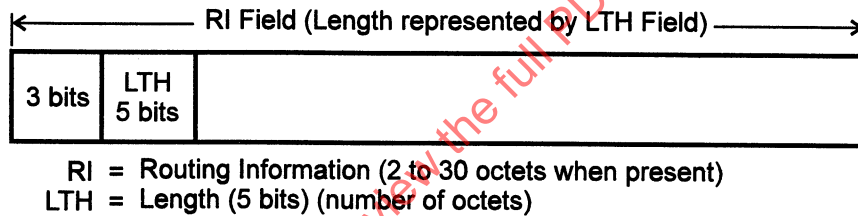

Figure 14—Routing information field

#### 3.2.5.1 Length bits (LTH)

These five bits indicate the length (in octets) of the RI field. Length field values shall be even values between 2 and 30, inclusive.

### 3.2.6 Information (INFO) field

The information field contains zero, one, or more octets that are intended for MAC, MGT, or LLC. The maximum length of the information field is limited by the maximum frame length as specified in 4.2.4.1, Counter, transmitted octets. The format of the information field is indicated in the frame-type bits of the FC field. The frame types defined are MAC frame and LLC frame.

#### 3.2.6.1 Order of bit transmission

Each octet of the information field shall be transmitted most significant bit first.

#### 3.2.6.2 MAC frame format

The format of the information field for MAC frames is specified in 3.3.2. All stations shall be capable of receiving MAC frames whose total length is the size of the largest frame specified in table 5. However, it is

recommended that all stations be capable of receiving MAC frames whose total length is up to and including 96 octets.

### 3.2.6.3 LLC frame format

The format of the information field for LLC frames is not specified in this standard. However, in order to promote interworking among stations, all stations shall be capable of receiving LLC frames whose information field is up to and including 133 octets in length.

### 3.2.7 Frame-check sequence (FCS) field

The FCS is a 32-bit sequence based on the following standard generator polynomial of degree 32.

$$G(X) = X^{32} + X^{26} + X^{23} + X^{22} + X^{16} + X^{12} + X^{11} + X^{10} + X^8 + X^7 + X^5 + X^4 + X^2 + X + 1$$

A valid FCS is the ones complement of the sum (modulo 2) of the following:

- The remainder of  $X^k (X^{31} + X^{30} + X^{29} + \dots + X^2 + X + 1)$  divided (modulo 2) by  $G(X)$ , where  $k$  is the number of bits in the FC, DA, SA, RI, and INFO fields, and
- The remainder after multiplication by  $X^{32}$  and then division (modulo 2) by  $G(X)$  of the content (treated as a polynomial) of the FC, DA, SA, RI, and INFO fields.

The FCS shall be transmitted commencing with the coefficient of the highest term. As a typical implementation, at the transmitter, the initial remainder of the division is preset to all 1's and is then modified by division of the FC, DA, SA, RI, and INFO fields by the generator polynomial,  $G(X)$ . The ones complement of this remainder is transmitted, most significant bit first, as the FCS. At the receiver, the initial remainder is preset to all 1's and the serial incoming bits of FC, DA, SA, INFO, RI, and FCS, when divided by  $G(X)$ , results, in the absence of transmission errors, in a unique nonzero remainder value. The unique remainder value is the polynomial:

$$X^{31} + X^{30} + X^{26} + X^{25} + X^{24} + X^{18} + X^{15} + X^{14} + X^{12} + X^{11} + X^{10} + X^8 + X^6 + X^5 + X^4 + X^3 + X + 1$$

### 3.2.8 Ending delimiter (ED) field

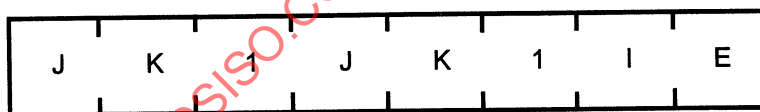

J = Non-data\_J symbol  
K = Non-data\_K symbol  
1 = Data\_one symbol  
I = intermediate frame bit  
E = error-detected bit

Figure 15—Ending delimiter field

The transmitting station shall transmit the delimiter as shown. Receiving stations shall consider the ED valid if the first six symbols (J K 1 J K 1) are received correctly.

#### 3.2.8.1 Intermediate frame bit (I bit)

The I bit is optionally transmitted as 1 in intermediate (or first) frames of a multiple-frame transmission. The I bit in the last or only frame of the transmission shall be transmitted as 0.

**3.2.8.2 Error-detected bit (E bit)**

The E bit shall be transmitted as 0 by the station when it originates the token, abort sequence, or frame. All stations on the ring check tokens and all frame formats for errors (for example, FCS error in a MAC or LLC frame or non-data symbols within a frame or token). The E bit of a frame being repeated is set to 1 when a frame with an error (4.3.2) is detected and, optionally, the E bit of a token being repeated is set to 1 when a token with an error (4.3.1) is detected; otherwise, the E bit is repeated as received.

**3.2.9 Frame status (FS) field**

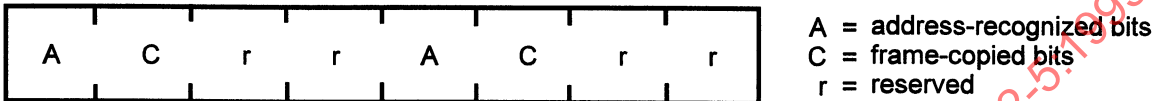

**Figure 16—Frame status field**

The reserved (r) bits are reserved for future standardization. They shall be transmitted as 0's and repeated as received.

**3.2.9.1 Address-recognized (A) bits and frame-copied (C) bits**

The A and C bits shall be transmitted as 0 by the station when it originates the frame. If another station recognizes the DA as its own address or relevant group address, or if indicated by the bridge interface, it sets both of the A bits to 1. If it copies the frame, it also sets both of the C bits to 1. The A and C bits are set without regard to the value of the received E bit and only if the frame is valid as defined in 4.3.2.

**3.2.10 Interframe gap (IFG) field**

The interframe gap is composed of fill (3.1.4) and shall be a minimum of 1 octet in length (a length of 2 octets is recommended) for 4 Mbit/s transmission and shall be a minimum of 5 octets in length for 16 Mbit/s transmission. Note that the size and content of the IFG may be altered (see 5.8.3.3). Receiving stations can not be assured of receiving the full IFG (5.8.3.3). Note that additional fill may follow the interframe gap.

**3.3 Medium Access Control (MAC) frames**

The following subclauses give descriptions of various MAC frames that are used in the management of the token ring. Definitions and requirements for PDU priority (Pm), FC, DA, INFO field content (Vector Class—VC, Vector Identifier—VI, Subvector Identifier—SVI, and Subvector Value—SVV) are also given.

**3.3.1 MAC frame control**

Frames with the following FC values are handled as follows:

- a) If the value of the FC of the frame is X'00' and it is addressed to the station, it will be copied only if there is sufficient free buffer available for copying.
- b) If the frame has an FC field value X'01' through X'3F', it is addressed to the station, and it has a Destination Class B'0000' (station), then every effort should be made to copy the frame. The MAC protocol (4.3.4) has been designed to handle the case when a MAC frame is not copied. FC values of X'01' through X'06' shall only be used for the corresponding MAC frames as defined in table 4.

### 3.3.2 MAC frame information field format

Figure 17 shows the format of the information field for MAC frames.

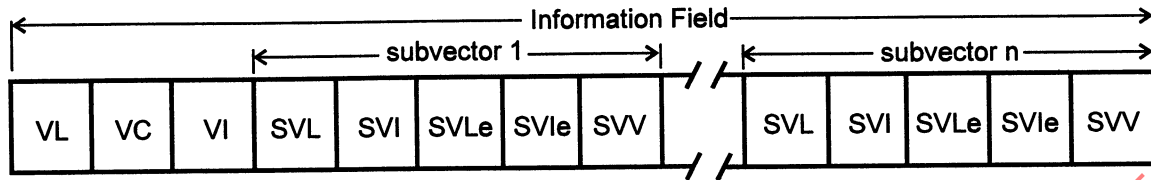

**Figure 17—MAC frame information field structure**

**Vector.** The fundamental unit of MAC and MGT information. A vector contains its length, an identifier of its function, and zero or more subvectors. Only one vector is permitted per MAC frame.

**VL (vector length).** A 16-bit binary number that gives the length, in octets, of the vector. The length includes the length of the VL field and can have values such that  $X'0004' \leq VL \leq X'FFFF'$ , subject to the other constraints in clause 4 on the length of the INFO field.

**VC (vector class).** A one-octet code point that identifies the function class of both the source and destination entities. The function classes are defined as follows:

**Table 2—Vector class values**

Function class	Class value
Ring station (RS)	X'0'
Configuration report server (CRS)	X'4'
Ring parameter server (RPS)	X'5'
Ring error monitor (REM)	X'6'
Network management (NM)	X'8'

The organization of the vector class field is shown in figure 18.

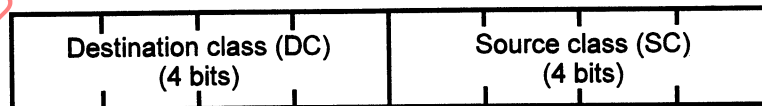

**Figure 18—Vector class field**

The VC field is divided into two 4-bit fields specifying the destination class (DC) and the source class (SC).

The DC field provides a means to route the frame to the appropriate management function within the station. Table 5 defines the MAC frames sent to destination class 0 that are processed by the ring station as specified in 4.3.4. All other MAC frames sent to destination class 0 may be ignored.

The SC field allows the station's MAC and MGT functions to reject vector identifiers from invalid sources.

**VI (vector identifier).** A one- or three-octet code point that uniquely identifies the vector. This field is one octet in length if the first octet is not X'FF' and three octets in length if the first octet is X'FF'. A value of X'FF' means the vector code is contained in the next two octets. The definition of all undefined vector codes used with a source class or destination class of zero (ring station) is reserved for future standardization.

**SV (subvector).** Vectors require all data or modifiers to be contained within subvectors. A separate subvector is required to contain each piece of data or modifier that is being transported. A subvector is not position-dependent within a vector, but rather, each subvector is identified by its subvector identifier.

**SVL (subvector length).** A one-octet field that uniquely identifies the length of the subvector depending on its value. If the SVL value is less than X'FF' then SVL contains the length, in octets, of the subvector including the length of SVL, SVI, SVIe (if present), and SVV fields. If the value of SVL is X'FF', then the subvector length is specified in the SVLe field.

**SVI (subvector identifier).** A one-octet field that identifies the subvector depending on its value. A value of X'FF' indicates the subvector code is contained in the SVIe field.

Definitions of the SVIe subvector codes are beyond the scope of this standard and are reserved for future standardization. The subvectors with code points from X'00' through X'7F' are defined to have the same definition for all vectors so that certain specific strings that are common to many vectors can be formatted and labeled in a standard manner. This standardization is intended to facilitate sharing of data between MAC and MGT applications and make the data as application-independent as possible. The subvectors with code points from X'80' through X'FE' are for specific definition within a particular vector-by-vector identifier. For example, the subvector X'90' can have an entirely different definition in every different vector. The subvector X'40' has only one definition across all vectors and applications. Subvectors themselves may contain other subvectors and other types of vectors and optional fields that are unique only to the particular subvector to which they belong.

**SVLe (extended subvector length).** A zero- or two-octet field depending on the value of SVL. If the SVL value is less than X'FF' then the length of SVLe is zero. When the SVL value is X'FF', then the length of the SVLe field is 2 octets and its value identifies the length, in octets, of the subvector including the length of the SVL, SVI, SVLe, SVIe (if present), and SVV fields.

**SVIe (extended subvector identifier).** A zero- or two-octet field depending on the value of SVI whose value identifies the subvector. If the value SVI is less than X'FF' then the length of SVIe is zero. When the SVI value is X'FF', the SVIe field is 2 octets in length and contains the code point identifying the subvector. The definition of the extended subvector identifier is provided for future expansion and definition of the SVIe subvector codes is reserved for future standardization.

**SVV (subvector value).** This field contains the subvector information as described in 3.3.4.

### 3.3.3 Vector descriptions

Following is a list of vectors used by the ring station in numerical order of the vector identifier.

**X'00'—Response (RSP).** The RSP MAC frame is sent by a station as specified by the MAC protocol to acknowledge receipt of, or to report an error in, a received MAC frame. The RSP MAC frame is never sent to Destination Class 0 (ring station). The RSP MAC frame is not required to be sent if the received frame initiating the response was sent to a broadcast address and the address-recognized and frame-copied bits in the FS field were all ones.

**X'02'—Beacon (BN).** The BN MAC frame is transmitted by a station which detects a continuing interruption to the data flow on the ring.

**X'03'—Claim Token (CT).** The CT MAC frame is used by stations when restoring the active monitor function to the ring.

**X'04'—Ring Purge (RP).** The RP MAC frame is transmitted by the active monitor to verify the ring data path before restoring the token.

**X'05'—Active Monitor Present (AMP).** The AMP MAC frame is transmitted periodically by the active monitor to indicate its presence on the ring and to initiate the Neighbor Notification Process.

**X'06'—Standby Monitor Present (SMP).** The SMP MAC frame is transmitted by standby monitor stations as part of the Neighbor Notification Process.

**X'07'—Duplicate Address Test (DAT).** The DAT MAC frame is used during the Join Ring Process to verify that the station's individual address is unique.

**X'08'—Lobe Media Test (TEST).** The TEST MAC frame is optionally used by a station during the Join Ring Process to test its lobe connection prior to inserting into the ring or at any time the station needs to test the transmission path such as during the Beacon Test state. When the TEST MAC frame is used, it is addressed to the null address which is specifically addressed to no station. The station determines the quality of the transmission path by inspecting the received frame for errors (see 4.3.2).

**X'0B'—Remove Ring Station (REMOVE).** The REMOVE MAC frame is sent to any of the station's non-broadcast addresses to force its removal from the ring. The REMOVE MAC frame is sent by a configuration report server (CRS) or optionally by network management (NM).

**X'0C'—Change Parameters (CHG\_PARM).** The CHG\_PARM MAC frame is sent by the CRS to a ring station to set its ring operating parameters. The ring station normally replies with the RSP MAC frame upon acceptance or rejection of the CHG\_PARM MAC frame (see X'00' RSP MAC Frame).

**X'0D'—Initialize Station (INIT).** The INIT MAC frame is sent by the RPS to a ring station to initialize its ring operating parameters. The ring station normally replies with the RSP MAC frame upon acceptance or rejection of the INIT MAC frame (see X'00' RSP MAC Frame).

**X'0E'—Request Station Addresses (RQ\_ADDR).** The RQ\_ADDR MAC frame is sent by any non-zero function class (such as CRS) to a station(s) to request the addresses recognized by the station.

**X'0F'—Request Station State (RQ\_STATE).** The RQ\_STATE MAC frame is sent by any non-zero function class (such as CRS) to a station(s) to request information on the state of the station.

**X'10'—Request Station Attachments (RQ\_ATTCH).** The RQ\_ATTCH MAC frame is sent by any non-zero function class (such as CRS) to a station(s) to request information on the functions active in the station.

**X'20'—Request Initialization (RQ\_INIT).** The RQ\_INIT MAC frame is sent by a station to the RPS as part of the join ring process. It informs the RPS that a station has been inserted and will accept modified parameters from either the RPS or CRS.

**X'22'—Report Station Addresses (RPRT\_ADDR).** The RPRT\_ADDR MAC frame is sent by a station in response to a Request Station Addresses MAC frame.

**X'23'—Report Station State (RPRT\_STATE).** The RPRT\_STATE MAC frame is sent by a station in response to a Request Station State MAC frame.

**X'24'—Report Station Attachments (RPRT\_ATTCH).** The RPRT\_ATTCH MAC frame is sent by a station in response to a Request Station Attachments MAC frame.

**X'25'—Report New Active Monitor (NEW\_MON).** The NEW\_MON MAC frame is sent by a station to the CRS to report that it has become the active monitor.

**X'26'—Report SUA Change (SUA\_CHG).** The SUA\_CHG MAC frame is sent by a station to the CRS when a change is made in the station's SUA as the result of the neighbor notification process.

**X'27'—Report Neighbor Notification Incomplete (NN\_INCMP).** The NN\_INCMP MAC frame is sent by the active monitor to the REM to report an error in the neighbor notification process.

**X'28'—Report Active Monitor error (ACT\_ERR).** The ACT\_ERR MAC frame is sent to the REM by an active monitor if it detects more than one station is active monitor on the ring or if another station indicates a problem with the active monitor function by initiating the Claim Token process.

**X'29'—Report Error (RPRT\_ERR).** The RPRT\_ERR MAC frame is sent to the REM by a station to report errors detected since the last error report.

The following VIs are reserved:

**X'01'—Re-IMPL**

**X'09'—Transmit forward**

**X'0A'—Resolve**

**X'2A'—Report transmit forward**

### 3.3.4 Subvector descriptions

Following is a list of subvectors, in numerical order of their respective subvector identifier values. The lengths specified are only for the SVV field and do not include the length of SVL and SVI fields.

**X'01'—Beacon Type.** This subvector has a value field 2 octets long and is used to indicate the type of fault detected. It has one of the following values:

X'0001'—Issued by a Dual Ring station during reconfiguration. Refer to IEEE Std 802.5c-1991 [B1].<sup>6</sup>

X'0002'—Signal loss.

X'0003'—Timer TCT expired during claiming token; no claim token frames received.

X'0004'—Timer TCT expired during claiming token; claim token frames received.

**X'02'—Upstream Neighbor's Address (UNA).** This subvector value field is 6 octets long and contains the address of the upstream neighbor of the sending station. When transmitting, this is the value of SUA. When received, the value of this subvector is referred to as Reported Upstream Address (RUA).

**X'03'—Local Ring Number.** This subvector has a value field 2 octets long. It indicates the local ring number of the sending station. This value is assigned to the station by the Initialize Station MAC frame or the Change Parameters MAC frame and is used in the subvector field of appropriate report frames. This value does not affect the MAC address assigned to the station.

<sup>6</sup> The numbers in brackets preceded by the letter B correspond to those of the bibliography in annex J.

**X'04'—Assign Physical Drop Number.** This subvector has a value field 4 octets long. It specifies the physical location of the target station. The value of this subvector is not defined by this standard. This value is assigned to the station by the Initialize Station MAC frame or the Change Parameters MAC frame and is used in the subvector field X'0B' of appropriate report frames.

**X'05'—Error Report Timer Value.** This subvector has a value field 2 octets long. It states the value of TER in increments of 10 ms.

**X'06'—Authorized Function Classes.** This subvector has a value field 2 octets long. It indicates the functional classes that are allowed to be active in the station. Valid range is B'0000 0000 0000 0000' to B'1111 1111 1111 1111' where each bit 0 to 15 corresponds to function class X'0' to X'F'. Defined function classes are the following:

**Table 3—Function class values**

Subvector value	Function class	Class value
B'xxxx 1xxx xxxx xxxx'	Configuration report server (CRS)	X'4'
B'xxxx x1xx xxxx xxxx'	Ring parameter server (RPS)	X'5'
B'xxxx xx1x xxxx xxxx'	Ring error monitor (REM)	X'6'
B'xxxx xxxx 1xxx xxxx'	Network Management (NM)	X'8'

Other function classes are reserved for future standardization.

**X'07'—Authorized Access Priority.** This subvector has a value field 2 octets long. The value is set by the system administrator and it may establish the maximum frame access priority (Pm) at which a station queues non-MAC frames.

**X'09'—Correlator.** This subvector has a value field 2 octets long and is used to associate responses received with requests sent. The value of the correlator SV for a frame sent in response to a received frame shall be the value of the received correlator SV. If the received frame does not contain a correlator, the MAC may send any value or omit the correlator SV in the transmitted frame.

**X'0A'—SA of Last AMP or SMP Frame.** This subvector has a value field 6 octets long and is used in the Report Neighbor Notification Incomplete MAC frame. Its value is the same as the value of LMP which is specified in table 7. A value of null indicates that the AMP frame was not received. A value equal to the station's address indicates either that the AMP frame was not received or that no SMP frames were received. Any other value indicates the SA of the last SMP frame received.

**X'0B'—Physical Drop Number.** This subvector has a value field 4 octets long. It reports the physical location of the sending station (see X'04' Assign Physical Drop Number).

**X'20'—Response Code.** This subvector has a value field 4 or 6 octets long and is used in the Response MAC frame. It consists of a 2-octet response code followed by the 1-octet vector class (VC) and the 1- or 3-octet vector identifier (VI) from the received MAC frame that caused the station to send the Response MAC frame. The response code values are as follows:

- X'0001'—Positive acknowledgment. The MAC frame was accepted by the station.
- X'8001'—MAC frame data field incomplete. The MAC frame was too short to contain the vector length and the vector ID.
- X'8002'—Vector length error. Vector length does not agree with the length of the frame or a subvector was found that did not fit within the vector.
- X'8003'—Unrecognized vector ID. The vector ID is not recognized by the station.
- X'8004'—Inappropriate source class. The source class is not valid for the VI.
- X'8005'—Subvector length error. The length of a recognized subvector conflicts with its expected length or is less than 2.
- X'8006'—Reserved.
- X'8007'—Missing subvector. A subvector required to process the MAC frame is not in the MAC frame.
- X'8008'—Subvector unknown. A subvector received in the MAC frame is not known by the adapter.
- X'8009'—MAC frame too long. The received frame was rejected because it exceeded maximum length.
- X'800A'—Function requested was disabled. The received MAC frame was rejected because the function requested was disabled.

**X'21'—Individual Address Count.** This subvector has a value field 2 octets long. The default value of X'00 00' means more than one individual address is not supported. A non-zero value specifies the number of individual addresses in use by this station.

**X'22'—Product Instance ID.** This subvector's value is used by a station manufacturer to identify a station's characteristics, such as serial number, machine type, model number, plant of manufacture, etc. The length of this subvector is not defined by this standard. It is recommended that this subvector be the "ResourceTypeID" managed object as specified by ISO/IEC 10742 : 1994.

**X'23'—Ring Station Version Number.** This subvector is used in the Request Initialization and Report Station State MAC frames. The length and value of this subvector is not defined by this standard.

**X'26'—Wrap Data.** The length and function of this subvector are product implementation choices. The subvector is used in the Lobe Media Test MAC frame.

**X'28'—Station Identifier.** This subvector has a value field 6 octets long and is used in the Report Station State MAC frame. It should uniquely identify the station. It is recommended that this value be a universally administered individual address.

**X'29'—Ring Station Status.** This subvector is used in the Report Station State MAC frame. The length and contents of this subvector are not specified by this standard. However, an application receiving this subvector may be able to determine its format by examination of the Product Instance ID subvector (X'22').

**X'2B'—Group Addresses.** This subvector has a value field of 4 or 6 octets in length. It contains a group address of the reporting station. When 4 octet values are used, the field will contain the low order 4 octets of the address and no assumptions can be made about the first 2 octets of the address. A value of all zeros is used to denote that a station does not support a group address or that a group address is not assigned. If more than one group address is recognized, then any of those addresses may be reported.

**X'2C'—Functional Addresses.** This subvector has a value field 4 octets long and specifies the functional addresses that are active in the reporting station (see 3.2.4.1).

**X'2D'—Isolating Error Counts.** This subvector has a value field 6 octets long and is used in the Report Error MAC frame. It indicates the number of each type of error detected since the last error report. Refer to

3.6 for a description of each of the counters. Isolating errors are errors that are known to occur between the reporting station and its upstream station. If a counter is not implemented, its value shall be reported as X'00.

- Octet 0—line error (CLE)
- Octet 1—internal error (CIE)
- Octet 2—burst error (CBE)
- Octet 3—AC error (CACE)
- Octet 4—abort sequence transmitted (CABE)
- Octet 5—reserved (X'00')

**X'2E'**—**Non-isolating Error Counts.** This subvector has a value field 6 octets long and is used in the Report Error MAC frame. It indicates the number of each type of error detected since the last error report. Refer to 3.6 for a description of each of the counters. The origin of Non-isolating errors are unknown. If a counter is not implemented, its value shall be reported as X'00'.

- Octet 0—lost frame error (CLFE)
- Octet 1—receive congestion (CRCE)
- Octet 2—frame-copied error (CFCE)
- Octet 3—frequency error (CFE)
- Octet 4—token error (CTE)
- Octet 5—reserved (X'00')

**X'30'**—**Error Code.** This subvector has a value field 2 octets long and is used in the Report Active Monitor Error MAC frame. It has one of the following values:

- X'0001' — Active monitor error, used when the active monitor receives a Claim Token MAC frame.
- X'0002' — Duplicate active monitor, used when the active monitor receives a RP or an AMP MAC frame that it did not transmit, indicating the presence of another active monitor.
- X'0003' — Duplicate address, used when a station in claim token receives a Claim Token MAC frame in which the SA equals the station's individual address (SA equal to MA) but the RUA is different from the station's SUA. This indicates that another station on the ring has the same individual address.

The following SVIs are reserved:

- X'27'**—**Frame Forward**
- X'2A'**—**Transmit Forward Status Code**
- X'2F'**—**Function Request ID**

### 3.3.5 MAC frame tables

Tables 4 and 5 are tabulations of MAC frame requirements for transmitting and receiving stations, respectively.

#### 3.3.5.1 MAC frames transmitted

A station shall support the frames shown in table 4. The Beacon, Claim Token, Ring Purge, Active Monitor Present, and Standby Monitor Present MAC frames shall be transmitted as shown. Other frames may be transmitted with additional subvectors.

MAC frames shall be queued for transmission with the Pm values specified in table 4. It is recommended that all MAC frames transmitted on a token be queued for transmission with a Pm of 7.

**Table 4—MAC frame transmit definitions**

Vector (VD)/Name	FC Pm	DA	VC		Subvector (SVI)/Name
X'00' Response	X'00' **2	SA of rcvd frame	X'*0'		X'09' Correlator **5 X'20' Response Code
X'02' **4 Beacon	X'02' **3	broadcast	X'00'		X'01' Beacon Type X'02' UNA X'0B' Physical Drop Number
X'03' **4 Claim Token	X'03' **3	broadcast	X'00'		X'02' UNA X'0B' Physical Drop Number
X'04' **4 Ring Purge	X'04' **3	broadcast	X'00'		X'02' UNA X'0B' Physical Drop Number
X'05' **4 Active Monitor Present	X'05' 7	broadcast -	X'00'		X'02' UNA X'0B' Physical Drop Number
X'06' **4 Standby Monitor Present	X'06' **1	broadcast	X'00'		X'02' UNA X'0B' Physical Drop Number
X'07' **4 Duplicate Address Test	X'01' **1	DA=MA	X'00'		none
X'08' Lobe Media Test	X'00' **1	Null	X'00'		X'26' Wrap Data
X'20' **4 Request Initialization	X'00' **1	FA(RPS)	X'50'	op_txo p_tx op_tx	X'02' UNA X'21' Individual Address Count X'22' Product Instance ID X'23' Ring Station Version Number
X'22' Report Station Addresses	X'00' **2	SA of request	X'*0'	op_tx op_tx	X'09' Correlator **5 X'02' UNA X'2B' Group Address X'2C' Functional Address(s) X'21' Individual Address Count X'0B' Physical Drop Number
X'23' Report Station State	X'00' **2	SA of request	X'*0'	op_tx op_tx	X'09' Correlator **5 X'28' Station Identifier X'29' Ring Station Status X'23' Ring Station Version Number
X'24' Report Station Attachments	X'00' **2	SA of request	X'*0'	op_tx op_tx	X'09' Correlator **5 X'06' Authorized Function Classes X'07' Authorized Access Priority X'2C' Functional Address(s) X'21' Individual Address Count X'22' Product Instance ID
X'25' **4 Report New Active Monitor	X'00' **1	FA(CRS)	X'40'	op_tx op_tx	X'02' UNA X'0B' Physical Drop Number X'22' Product Instance ID
X'26' **4 Report SUA Change	X'00' **1	FA(CRS)	X'40'	op_tx	X'02' UNA X'0B' Physical Drop Number
X'27' **4 Report Neighbor Notification Incomplete	X'00' **1	FA(REM)	X'60'		X'0A' SA of Last AMP or SMP Frame
X'28' **4 Report Active Monitor Error	X'00' **1	FA(REM)	X'60'	op_tx	X'30' Error Code X'02' UNA X'0B' Physical Drop Number
X'29' **4 Report Error	X'00' **1	FA(REM)	X'60'	op_tx	X'2D' Isolating Error Count X'2E' Non-isolating Error Count X'02' UNA X'0B' Physical Drop Number

NOTES:—VC=X'\*0' indicates the destination class of the requesting entity.

\*\*1 indicates Pm=7 or 3.

\*\*3 Frames transmitted without waiting for a token.

\*\*5 See 3.3.4 for exception to X'09' Correlator SV.

\*\*2 indicates Pm=7 or 0.

\*\*4 Shall not be transmitted with an RI field.

op\_tx indicates SV is optional and may be omitted.

### 3.3.5.2 MAC frame reception

A station shall support reception of the frames as defined in table 5.

**Table 5—MAC frame receive definitions**

Vector (VI)/Name	FC	VC		Subvector (SVI)/Name
X'02' Beacon	X'02'	X'00'	req req op_req	X'01' Beacon Type X'02' UNA X'0B' Physical Drop Number
X'03' Claim Token	X'03'	X'00'	req op_req	X'02' UNA X'0B' Physical Drop Number
X'04' Ring Purge	X'04'	X'00'	req op_req	X'02' UNA X'0B' Physical Drop Number
X'05' Active Monitor Present	X'05'	X'00'	req op_req	X'02' UNA X'0B' Physical Drop Number
X'06' Standby Monitor Present	X'06'	X'00'	req op_req	X'02' UNA X'0B' Physical Drop Number
X'07' Duplicate Address Test	X'01'	X'00'		none
X'0B' Remove Ring Station	X'01'	X'04'		none
X'0C' Change Parameters	X'00'	X'04'		X'09' Correlator X'03' Local Ring Number X'04' Assign Physical Drop Number X'05' Error Timer Value X'06' Authorized Function Classes X'07' Authorized Access Priority
X'0D' Initialize Station	X'00'	X'05'		X'09' Correlator X'03' Local Ring Number X'04' Assign Physical Drop Number X'05' Error Timer Value
X'0E' Request Station Addresses	X'00'	X'0*'		X'09' Correlator
X'0F' Request Station State	X'00'	X'0*'		X'09' Correlator
X'10' Request Station Attachments	X'00'	X'0*'		X'09' Correlator

NOTES— VC=X'0\*' indicates any nonzero source class.

VC=X'04' may also include X'08'.

req means the SV is required to be present for the frame to be considered valid.

op\_req means that the station may optionally require this subvector to be present. A station may optionally receive the Initialize Station MAC frame (Vector x'0D') with an FC value of X'01'. Management servers transmitting this frame are recommended to use FC values of both X'00' and X'01'.

When a valid (4.3.2) MAC frame addressed to the station is copied, it is processed as follows. When the destination class (DC) is other than X'0', the frame is indicated to the management interface (MGT\_UNITDATA.indication) and no other action is taken by the MAC protocol. When the DC is X'0', then the station performs a validity check and, based on that verification, takes the actions specified in table 7. The station ignores or rejects frames as follows:

- RI\_INVALID:** The station may ignore any MAC frame containing an RI field.
- VI\_UNK:** Unrecognized vector ID value. The station shall reject the frame if the VI value is not known by the station. The station may reject or ignore the frame if the FC field does not match the value specified for the VI in table 5. Validity checking of the FC field is not required by this standard
- VL\_LTH\_ERR:** Vector length error. The station shall reject the frame if the VL does not agree with the length of the frame, or if the VL is not equal to the sum of all the SVLs plus the length of VL, VC, and VI fields.
- SHORT\_MAC:** MAC frame too short. Based on the VI value, the station may reject the frame if the length of the frame is not sufficient to contain all of the required subvectors. As a minimum, the frame must contain VL, VC, and VI fields and all subvectors listed as required in table 5 (also see SV\_MISSING).
- LONG\_MAC:** MAC frame too long. The station may reject the frame if the VL indicates a size larger than that needed for all allowed subvectors.
- SV\_LTH\_ERR:** Subvector length error. The station shall reject the frame if the subvector length is less than the minimum or greater than the maximum specified in 3.3.4.
- SV\_MISSING:** Missing required subvector. Based on the VI, the station shall reject a frame that does not contain a subvector listed as "req" in table 5. The station may additionally reject the frame if it does not contain a subvector listed as "op\_req" in table 5. The station shall not require subvectors that are not listed in table 5.
- SV\_UNK:** SVI value unknown. The station may reject the frame if the SVI value is not known by the station. The station shall recognize all SVI values given in table 5.
- SC\_INVALID:** Invalid source class. The station shall reject the frame if the VC does not match the value specified in table 5.
- FUNCTION\_DISABLED:** The requested function is disabled by management.

The order of parsing received frames is not specified by this standard. Annex H has been provided as an example of frame validity parsing.

As specified in 4.3.4, certain MAC frames require a response frame if the frame is rejected.

**Setting parameters:** When a valid Change Parameters or Initialize Station MAC frame is received, the local parameters are set to the value specified. These parameters are used as follows:

- X'03'—Local ring number: This parameter is reserved for use by management and not otherwise used by the station.
- X'04'—Assign physical drop number: This parameter is used as the X'0B' Physical Drop Number subvector in appropriate MAC frames transmitted by the station (3.3.5.1).
- X'05'—Error timer value: When set, the value of this subvector becomes the time interval for the error timer TER (3.4.5).
- X'06'—Authorized function classes: When set, this subvector defines which function classes may be active in a station. The default is that all function classes are allowed. If a function class is not enabled, the station shall not transmit frames with the corresponding source class, the station shall not set the functional address assigned to that function, and thus shall not set the A bits in frames addressed to the functional address assigned to that function.
- X'07'—Authorized access priority: When set, this parameter may establish the maximum priority used for queuing non-MAC frames. The default is that any priority except 7 may be used. A station is not required to take any action based on this parameter.

### 3.4 System timing parameters

Except for the token holding time, system timing parameters are specified by the definition of specific timers.

### 3.4.1 Token holding time

Token holding time is the length of time, after capturing a token, that a station may continue to transmit frames before releasing the token. This time is specified in terms of the equivalent number of octets transmitted in a period of 9.1 ms. Refer to "Counter, Transmitted Octets (CTO)" in 4.2.4.1. The MAC protocol uses the CTO counter to determine whether the next frame can be completely transmitted in the time remaining. The difference between the 9.1 ms used for the basis of CTO and the minimum value of TVX is not dependent on ring latency.

### 3.4.2 Timers

In general, timers control the maximum period of time that a particular condition may exist. All timers are stopped when the bypass state (J0) of the join state machine is entered (refer to clause 4 for details) and do not start until the first time they are reset. In defining the timers, the terms *reset* and *expired* are used, as explained below.

- **reset:** The term *reset* means that timing is started for an interval equal to the value of the timer.
- **expired:** The term *expired* means that a time interval equal to the timer value has elapsed since the timer was reset. A timer that expires remains stopped until reset.

Each timer is described below with detailed operation specified in 4.3.4.

#### 3.4.2.1 Timer, active monitor (TAM)

Each station shall have a timer TAM. This timer is used by the active monitor function to stimulate the enqueuing of an AMP PDU for transmission. The value of TAM shall be between 6.8 s and 7.0 s.

#### 3.4.2.2 Timer, beacon repeat (TBR)

Each station shall have a timer TBR. This timer is reset each time the station receives a beacon MAC frame while in Beacon Repeat to allow the station to detect the absence of the beacon MAC frames. The absence of beacon MAC frames is detected by the timer TBR expiring and causes entry into Transmit Claim Token. The value of TBR shall be between 200 ms and 400 ms. A value of 200 ms is recommended.

#### 3.4.2.3 Timer, beacon transmit (TBT)

Each station shall have a timer TBT. This timer is used to specify the length of time a station remains in Transmit Beacon before entering Beacon Test. The value of TBT shall be between 15.8 s and 26 s. A value of 16 s is recommended.

#### 3.4.2.4 Timer, claim token (TCT)

Each station shall have a timer TCT. This timer is reset either when entering Transmit Claim token or upon reception of the first claim token MAC frame. It is used to detect the failure of the Claim Token process and allow the Monitor FSM to enter Beacon Transmit state or the Join FSM to remove the station from the ring. The value of TCT shall be between 1.0 s and 1.2 s.

#### 3.4.2.5 Timer, error report (TER)

Each station shall have a timer TER. This timer is used to report errors that have been detected by the station. When an error counter is incremented, TER, if not already running, is reset. The station queues a Report Error PDU and resets all error counters to zero when TER expires. The default value of TER shall be between 2.0 s and 2.2 s. This value can be changed by the Change Parameters MAC frame or the Initialize Station MAC frame.

#### 3.4.2.6 Timer, insert delay (TID)

Each station shall have a timer TID. This timer is used to delay the station's recognition of its own beacon MAC frames until sufficient time has elapsed after Beacon Test to assure the PHY has put the station in the ring's data path (no longer wrapped at the TCU). This is done to prevent premature resolution of beaconing (refer to clause 4 for details). The value of TID shall be between 5 s and 20 s.

#### 3.4.2.7 Timer, join ring (TJR)

Each station shall have a timer TJR. This timer is used by the inserting station to detect the failure of the join ring process. The value of TJR shall be between 17.8 s and 18.0 s.

#### 3.4.2.8 Timer, no token (TNT)

Each station shall have a timer TNT. This timer is used to recover from various token related error situations. The operation of timer TNT is described in clause 4. The value of TNT shall be between 2.6 s and 5.2 s. A value of 2.6 s is recommended.

#### 3.4.2.9 Timer, queue PDU (TQP)

Each station shall have a pacing timer TQP. This timer is used to schedule the following events:

- a) The enqueueing of a SMP PDU after reception of an AMP or a SMP MAC frame in which the A and C bits were equal to 0 when in the Repeat state (MS=RPT).
- b) The transmission of a Claim Token MAC frame when in Transmit Claim Token state (MS=TCT).
- c) The transmission of a Beacon MAC frame when in Transmit Beacon state (MS=TBN).

The value of TQP shall be between 10 ms and 20 ms. A value of 20 ms is recommended.

#### 3.4.2.10 Timer, remove hold (TRH)

Each station shall have a timer TRH. This timer is used to delay the remove action for a minimum amount of time after insertion. This time allows the TCU to accomplish the station's insert request before the station issues the remove request. This timer is specified for interoperability with TCUs built prior to this specification. The value of the TRH shall be between 5 and 7 s.

#### 3.4.2.11 Timer, remove wait (TRW)

Each station shall have a timer TRW. This timer is used to control the time a station must remain in repeat to allow sufficient time for the TCU to remove the inserted station's lobe from the ring (see 7.2.1.1). The value of TRW shall be a minimum of 200 ms.

#### 3.4.2.12 Timer, request initialize (TRI)

Each station shall have a pacing timer TRI. This timer is used during join ring to detect that a response to the last Request Initialization MAC frame was not received and cause the Request Initialization MAC frame to be enqueued after the join ring FSM has completed neighbor notification. The value of TRI shall be between 2.5 s and 2.8 s.

#### 3.4.2.13 Timer, return to repeat (TRR)

Each station shall have a timer TRR. This timer is used to ensure that the transmitting station returns to the Repeat state. The value of TRR shall be between 4.0 ms and 4.1 ms.

#### 3.4.2.14 Timer, ring purge (TRP)

Each station shall have a timer TRP. This timer is used by the station to detect the failure of ring purge and exit to the Transmit Claim Token state. The value of TRP shall be between 1.0 s and 1.2 s.

#### 3.4.2.15 Timer, signal loss (TSL)

Each station shall have a timer TSL. This timer is used to determine whether or not the PHY "signal\_loss" condition is in a steady state. The value of TSL shall be between 200 ms and 250 ms.

#### 3.4.2.16 Timer, standby monitor (TSM)

Each station shall have a timer TSM. This timer is used to assure that there is an active monitor on the ring or to detect token streaming. The value of TSM shall be between 14.8 s and 15.0 s.

#### 3.4.2.17 Timer, valid transmission (TVX)

Each station shall have a timer TVX. This timer is used by the active monitor to detect the absence of frames or tokens. The value of this timer indirectly limits the maximum number of octets a station may transmit after capturing a token (token holding time) before it must release a token. The value of TVX shall be between 10.0 ms and 11.0 ms.

#### 3.4.2.18 Timer, wire fault delay (TWFD)

Each station shall have a timer TWFD. This timer is used to delay the detection of wire fault after Join Ring completes (JS=JC, refer to clause 4) or the station inserts after Beacon Test. The value of TWFD shall be between 5.0 s and 10.0 s. The sum of TWFD + TWF shall be a minimum of 7.0 s.

#### 3.4.2.19 Timer, wire fault (TWF)

Each station shall have a timer TWF. This timer is used to provide a sampling time for filtering wire fault. The value of TWF shall be between 0 s and 10 s. A value of 5 s is recommended.

### 3.5 Station policy flags

The station policy flags ("O"—suffix acronym) are set external to the MAC (see 6.1.3.1.2) and are not changed by the MAC state machines. Additional station operation flags are defined in clause 4. The station policy flags define the following policies:

- a) Beacon handling method (FBHO)
- b) Claim token contention method (FCCO)
- c) Early token release support (FETO)
- d) Medium rate (FMRO)
- e) Token error isolation and reporting support (FTEO)
- f) Token handling method (FTHO)
- g) Reject remove frame support (FRRO)
- h) Priority operation on multiple frame transmissions (FMFTO)
- i) Error report timing method (FEEO)
- j) Good token detection method (FGTO)

### 3.5.1 Flag, beacon handling option (FBHO)

The flag FBHO is used to indicate how the station handles participation in beaconing prior to the station completing the join ring process. The station fully participates in beaconing as follows.

- a) If the value of flag FBHO is 0, upon completion of the Join FSM Neighbor Notification state J5.
- b) If the value of flag FBHO is 1, upon completion of the Join FSM Request Initialization state J6.

The FBHO value of 0 is recommended (improves beacon handling in the JS=RQI state).

### 3.5.2 Flag, claim contender option (FCCO)

The flag FCCO is used to indicate how the station behaves upon reception of a claim token MAC frame with a source address lower than its specific address. The station enters the Transmit Claim Token state when flag FCCO is set to 1. The station does not enter the Transmit Claim Token state when flag FCCO is set to 0. This policy flag is not taken into account if this station is the one that detects the error necessitating entry of the claim process.

### 3.5.3 Flag, early token release option (FETO)

The flag FETO is used to indicate whether or not the Early Token Release option for 16 Mbit/s operation is selected. If flag FETO is set to 1, the ETR option is active. If flag FETO is set to 0, the ETR option is inactive. For 4 Mbit/s operation, the value of the FETO flag has no significance.

### 3.5.4 Flag, error counting option (FECO)

A station accumulates errors for a period determined by the error report timer (TER) and reports all errors that occurred during that period. If FECO=0, the station resets TER when the first error is received and, when TER expires, sends an error report frame. If FECO=1, each time TER expires the station resets TER and, if any of the error counters are not zero, sends the error report frame.

### 3.5.5 Flag, medium rate option (FMRO)

The flag FMRO is used to indicate the operating speed of the ring as follows: If flag FMRO is set to 1, the station is operating at 16 Mbit/s. If flag FMRO is set to 0, the station is operating at 4 Mbit/s.

### 3.5.6 Flag, multiple frame transmission option (FMFTO)

The flag FMFTO is used to indicate how the station handles the reservation field during the transmission of multiple frames.

- a) If flag FMFTO is set to 0, the station examines Pr and Rr each time it transmits the ending frame sequence. For those cases where the queue is not empty, the following occurs:
  - 1) If  $P_m < R_r$  or  $P_m < P_r$ , the frame being transmitted is the last frame to be transmitted.
  - 2) If  $P_m \geq P_r$  and  $P_m \geq R_r$ , the next frame from the queue is transmitted.
- b) If flag FMFTO is set to 1, the station examines Pr (ignores Rr) each time it transmits the ending frame sequence. For those cases where the queue is not empty, the following occurs:
  - 1) If  $P_m < P_r$ , the frame being transmitted is the last frame to be transmitted.
  - 2) If  $P_m \geq P_r$ , the next frame from the queue is transmitted.

The FMFTO value of 0 is recommended (allows high priority reservations to be honored earlier when the station is performing multiple frame transmit per token resulting in lower latency for higher priority traffic).

### 3.5.7 Flag, reject remove option (FRRO)

A station policy flag that controls how the MAC protocol responds to a Remove frame. If the value of FRRO is 0, then the station will remove from the ring. If the FRRO value is 1, then the station will send a response frame indicating that the function is disabled.

### 3.5.8 Flag, token error detection option (FTEO)

The flag FTEO is used to indicate how the station handles token errors as follows:

- a) If flag FTEO is set to 0, isolation and reporting of code violations in a token is supported.
- b) If flag FTEO is set to 1, isolation and reporting of code violations in a token is not supported.

The FTEO value of 0 is recommended (provides additional error checking of ring data).

### 3.5.9 Flag, token handling option (FTHO)

The flag FTHO is used to indicate how the active monitor station detects the absence of a token or frame.

- a) If flag FTHO is set to 0, expiration of the timer TVX is used to detect the absence of tokens or frames.
- b) If flag FTHO is set to 1, expiration of the timer TVX is used in conjunction with the FAT flag to detect the absence of tokens or frames. (FAT is defined in clause 4.)

### 3.5.10 Flag, good token option (FGTO)

The flag FGTO is used to indicate how the station detects the presence of a token as follows:

- a) If flag FGTO is 0, then good token detection consists of detecting either
  - 1) A valid token with priority of 0, or
  - 2) A valid token with priority greater than 0 followed by a frame.
- b) If flag FGTO is 1, then good token detection consists of detecting any valid token.

## 3.6 Error counters

An error counter ("E"—suffix acronym) is incremented when a particular error condition occurs and is set to zero (0) when the contents of the error counter is reported. These counters have a range of 0 to 255. When the count reaches 255 (X'FF'), the count freezes until its value is reported.

### 3.6.1 Counter, abort error (CABE)

The counter CABE is incremented when a station prematurely ends a transmission by transmitting an abort sequence.

### 3.6.2 Counter, ac error (CACE)

CACE is incremented when a station receives an AMP or SMP MAC frame in which A and C are both equal to 0, and then receives another SMP MAC frame with both A and C equal to 0 without first receiving an AMP frame.

### 3.6.3 Counter, burst error (CBE)

A burst5\_error is indicated when the station detects the absence of transitions at the receiver input (see 5.4.2). During a single period of signal interruption, multiple burst errors are often indicated due to random noise; in addition, channel characteristics may cause a burst4 error repeated by a station to be detected as a burst5, at the next station. When this condition occurs, even though the station transforms the burst5 into a burst4, each time the burst4 propagates around the ring, it will be detected as a burst5, quickly causing the burst error counter to reach its maximum count. To aid in problem determination, the counter CBE is only required to be incremented once during each interval of signal disruption. The counter may be inhibited after a burst5\_error has been indicated until an event is received that indicates the station is receiving a valid signal. At a minimum, the reception of a MAC frame addressed to the station shall enable the counting of CBE. Alternative events include the reception of a SD, the reception of an ED, or either. A station may count every burst5 error.

### 3.6.4 Counter, frame-copied error (CFCE)

The counter CFCE is incremented when a station recognizes a frame addressed to its specific address and detects that the A bits in the FS field are set to 1, indicating a possible duplicate address. Stations are not required to increment this counter for frames other than MAC frames or for frames that contain an RI field.

### 3.6.5 Counter, frequency error (CFE)

The counter CFE is incremented when a frequency error is indicated (see 5.7.2).

### 3.6.6 Counter, internal error (CIE)

The counter CIE is incremented when a station recognizes a recoverable internal error. Reports of this error may be used to identify a station in marginal operating condition.

### 3.6.7 Counter, line error (CLE)

The counter CLE is incremented when a frame is copied or repeated by a station, the E bit is zero, and the frame is a "FR\_WITH\_ERR" (see 4.3.2). Optionally, a station may also increment this counter when it repeats a token containing an error as specified in 4.3.1. See 3.5.8.

The first station detecting a line error sets E=1 in the ED of the frame or token to prevent other stations from also counting the error and to enable isolation of the source of the disturbance to a fault domain.

### 3.6.8 Counter, lost frame error (CLFE)

The counter CLFE is incremented when a station's TRR timer expires during transmit strip operation. This count indicates how often frames transmitted by a station fail to return to it.

### 3.6.9 Counter, receive congestion error (CRCE)

The counter CRCE is incremented when a station sets the A bits to 1 in the FS field but does not copy the frame (C bits are not changed).

### 3.6.10 Counter, token error (CTE)

The counter CTE is incremented by an active monitor when it recognizes an error condition that requires it to purge the ring and restore a token. This occurs as the result of timer TVX expiring or when the active monitor receives a frame or token with the M bit set.

## 4. Token ring protocols

### 4.1 Overview

An informative overview of frame transmission, reception, and token ring operation is provided in 4.1 and 4.2. The normative specification of the operation is provided in 4.3. The handling of the undefined frame formats (3.2.3.1) is not described and is a subject for future standardization.

#### 4.1.1 Frame transmission

Station access to the physical medium (the ring) is controlled by passing a token around the ring. When a PDU is requested to be transmitted it is normally queued awaiting the reception of a token.

As a token passes a station it may give that station an opportunity to transmit one or more frames. In order for a station to transmit a frame, the received token must have a priority less than or equal to that of the queued PDU. If the token priority is greater than the priority of the queued PDU, or a frame is repeated on the ring before a token is received, the station requests a token of appropriate priority by setting the R reservation bits in the AC field of the frame or token.

When a token of suitable priority is received, it is changed to a start-of-frame sequence by transmitting the token bit as a one and the M and R bits as zero. At this point the station stops repeating the incoming signal and begins transmitting the queued PDU by sending the FC, DA, SA, RI (if present), and INFO fields. During transmission, the FCS of the frame is calculated and transmitted between the INFO field and the ending delimiter. After transmission of the ending delimiter, a Frame Status field is transmitted with the A and C bits zero followed by the required interframe gap.

#### 4.1.2 Token transmission

After transmission of the last or only frame has been completed, the station releases a token according to the token release station policy flag FETO (3.5.3).

- a) *Early token release.* The station releases this token as soon as it has completed transmission of the inter-frame gap.
- b) *Normal token release.* The station does not release the token until the station verifies that the last frame transmitted has returned to the station. The station does not release a token if the SA of the frame being stripped is not the same as the SA of the last frame it transmitted. If the SA has been verified at the time the station finishes transmitting the frame, then the token is transmitted at the end of the inter-frame gap; otherwise, the token is not transmitted until the SA is verified.

#### 4.1.3 Stripping

The station removes (strips) all frames from the ring that it originates by transmitting fill until the ending delimiter of the last frame that the station originated is removed from the ring. The station performs the stripping process by counting the number of frames transmitted and not repeating the received symbols (stripping) until the same number of frames have been received.

Early token release and transmitting multiple frames per token require stations to compensate for understripping (failure of a station to strip all of the frames it transmitted) and overstripping (a station stripping the frame following the last frame it transmitted). A single bit error may destroy a starting delimiter or ending delimiter causing a frame to be lost (not counted) which results in overstripping. There are also error conditions that cause delimiters to be created. The most common source for generating erroneous

delimiters is the switching action of certain types of TCUs. This TCU switching noise is characterized by multiple burst errors and ending delimiters. If the station stops stripping on the first of a series of erroneous ending delimiters, then not only will the station be understripping, but the following erroneous ending delimiters are detected by subsequent transmitting stations as indications of overstripping. Even though the understrip condition will be corrected by the active monitor (M bit inspection and setting), the ill effects of understripping are far more undesirable than those of overstripping; therefore, understripping should be avoided even at the cost of overstripping. Stripping is performed as follows:

- a) *To account for lost frames.* Each time the station transmits a frame, it increments its frame counter and temporarily saves the SA of the frame (only the SA of the last frame transmitted is saved). Each frame received will decrement the frame counter. While the frame counter is greater than 1, the station strips all received frames. When the frame counter is 1 (or less), the station compares the SA of the last frame transmitted to the SA of the received frame. If the frame is not corrupted (SA composed of only Data\_zero and Data\_one symbols) and the SA's do not compare, the station stops stripping, allowing the ending delimiter to be repeated as an indication of overstripping to the next transmitting station. Otherwise, the station stops stripping after the ED is received, completely removing the frame from the ring.
- b) *To account for overstripping by a previous station.* If after the station transmits its first ending delimiter and before receiving a starting delimiter, an ending delimiter is received, the station counts it as the end of its first frame and decrements its frame counter. If only a single frame was transmitted, (frame count=0), the station stops stripping. To prevent understripping, the exception to this rule is when a burst error is detected.
- c) *To prevent understripping.* The station does not count frames (ending delimiters) received before the first ending delimiter is transmitted. After the first ending delimiter is received, the station only counts complete frames (i.e., one starting delimiter and one ending delimiter). When a burst error is detected, the station may count the current frame but should not stop stripping until after the next starting delimiter is detected. When the burst error occurs in the last or only frame, the station uses the value of the SA in the next frame (as described above) to determine if the station has lost a frame and thus is overstripping.

#### 4.1.4 Frame reception

##### 4.1.4.1 Frame reception process

While the station is inserted, the station inspects the incoming signal stream and checks it for frames that should be copied or acted upon. If the frame's DA field matches the station's individual address, relevant group address(s), an active functional address, or a broadcast address, the frame (FC, DA, SA, RI, INFO, and FS fields) is copied and subsequently indicated to the appropriate sublayer. While the station is receiving a frame (even if the frame is not being copied), the station checks the frames validity by 1) calculating the FCS and comparing it to the FCS of the received frame, and 2) observing Manchester code violations (presence of a Non-data\_J or Non-data\_K symbol) between the SD and ED fields. If either of these error conditions exist, the frame's address-recognized bits and frame-copied bits are not set by the station, but the station sets the error bit in the frame's ending delimiter.

##### 4.1.4.2 Bridge interface interactions

To support MAC bridges (ISO/IEC 10038 : 1993), each valid received frame (FR) is indicated at the bridge service interface (M\_UNITDATA.indication). If the bridge entity responds with the optional M\_UNITDATA.response, then the station sets the A bits, and if the frame is successfully copied, the station sets the C bits. The bridge entity sends a frame by issuing an M\_UNITDATA.request and the MAC will queue the frame for transmission.

#### 4.1.5 Priority operation

The current ring service priority is indicated by the priority bits in the AC field of a frame or token on the ring. The priority bits (P) and the reservation bits (R) contained in the AC field work together in an attempt to match the service priority of the ring to the highest priority PDU that is queued for transmission. The value of the priority bits (P) and reservation bits (R) of the most recently received AC field are stored in registers as Pr and Rr, respectively.

The priority mechanism operates in such a way that *fairness* (equal access to the ring) is maintained for all stations within a priority level. This is accomplished by having the same station that raised the service priority level of the ring (*stacking station*) return the ring to the original service priority. To perform this function, two push-down stacks are defined whose top-most values are designated Sr and Sx. The following operations are defined on each stack:

- STACK: Push a value onto the top of the stack.
- POP: Remove the top-most value from the stack and discard. (Note that the top-most value of a stack is assumed to be visible for comparison with other parameters without popping.)
- RESTACK: Pop the top-most value and push a new value onto the stack.

The priority mechanism is explained as follows:

When a station has a priority (a value greater than zero) PDU (or PDUs) ready to transmit, it requests a priority token. This is done by changing the reservation bits (R) as the station repeats the AC field. If the priority level (Pm) of the PDU that is ready for transmission is greater than the R bits, the station increases the value of R field to the value Pm. If the value of the R bits is equal to or greater than Pm, the reservation bits (R) are repeated unchanged.

After a station has captured the token, it transmits PDUs that are at or above the present ring service priority level until it has completed transmission of those PDUs or until the transmission of another frame could not be completed within the allocated token holding time (see 3.4). The station may optionally terminate transmission of frames when the reservation field of the frame being stripped is higher than the pending transmit priority. All transmitted frames are sent at the present ring service priority value. The station will then generate a new token for transmission on the ring.

While the station is receiving the frames that it transmitted, the value of Rr indicates the highest reservation request by the other stations. If the station does not have additional PDUs to transmit that have a priority (Pm) greater than the present ring service priority, and does not have a reservation request (as contained in register Rr) which is greater than the present ring service priority (as contained in register Pr), the token is transmitted with its priority at the present ring service priority and the reservation bits (R) at the greater of Rr or Pm and no further action is taken.

However, if the station has a PDU ready for transmission or a reservation request (Rr), either of which is greater than the present ring service priority, the token is generated with its priority at the greater of Pm or Rr and its reservation bits (R) as 0. Since the station has raised the service priority level of the ring, the station becomes a stacking station and, as such, stores the value of the old ring service priority as Sr and the new ring service priority as Sx (STACK operation). These values will be used later to lower the service priority of the ring when there are no PDUs ready to transmit on the ring whose Pm is equal to or greater than the stacked Sx.

Note that since a station may have raised the service priority of the ring more than once before the service priority is returned to a lower priority (for example, from 1 to 3 and then 5 to 6), it may have multiple Sx and Sr values stored and, hence, be referred to as stacked.

Having become a stacking station, the station captures every token that it receives that has a priority (P) equal to its  $S_x$  in order to examine the R bits of the AC field for the purpose of lowering the service priority of the ring. If the station has no PDUs to transmit at the present ring service priority, the new token is transmitted with its P bits equal to either the value of the reservation bits (R), the value of the  $S_r$ , or the value of  $P_m$ , whichever is greater.

If the value of the new ring service priority is greater than  $S_r$  (P equal to  $R_r$  or  $P_m$ ), then R bits are transmitted as 0, the old  $S_x$  value is replaced with a new value equal to the new P value, and the station continues its role as a stacking station (RESTACK operation).

However, if the  $R_r$  and  $P_m$  values are equal to or less than the value of the  $S_r$ , the new token is transmitted at a priority value of  $S_r$  and both  $S_x$  and  $S_r$  are removed (popped) from the stacks (POP operation). If no other values of  $S_x$  and  $S_r$  are stacked, the station discontinues its role as a stacking station. The R bits of the new token are transmitted as the value of  $R_r$  or  $P_m$ , whichever is greater.

Note that a stacking station that has captured the token may transmit PDUs instead of performing the priority operation as described above. Only those PDUs that have a priority equal to or greater than the ring service priority may be transmitted.

The frames that are transmitted to initialize the ring have a P field that is equal to 0. The receipt of a P field whose value is less than a stacked  $S_x$  will clear the stacks.

The complete specification of priority operation is contained in table 7.

#### 4.1.6 Token ring fault detection, reporting, and recovery

Token ring error conditions are classified as either hard errors or soft errors.

- a) Hard errors are defined as faults that prevent frames and/or tokens from circulating around the ring.
- b) Soft errors are defined as faults that cause data corruption, but do not prevent frames and tokens from circulating around the ring.

Error detection, reporting, and recovery procedures require stations to identify and isolate fault conditions, and, in some cases, require the station causing the fault condition to remove from the ring.

Error conditions are isolated to fault domains (4.1.6.1) previously established by the Neighbor Notification process (4.1.6.2) and reported (4.1.6.3) by beacon MAC frames or Error Report MAC frames. Recovery from error conditions is managed by a strict ring recovery hierarchy (4.1.6.4) using the Ring Purge process, (4.1.6.5), the Claim Token process (4.1.6.6), and the Beacon process (4.1.6.7).

##### 4.1.6.1 Fault domain

A fault domain establishes a boundary around a fault condition and identifies the location of the fault for the appropriate corrective action. The fault domain consists of the following as illustrated in figure 19:

- a) The station *downstream* to the fault condition. This station reports the error (G).
- b) The station *upstream* to the station reporting the error (F).
- c) The components (e.g., ring medium, concentrators, etc.) between the reporting station (G) and its upstream station (F).

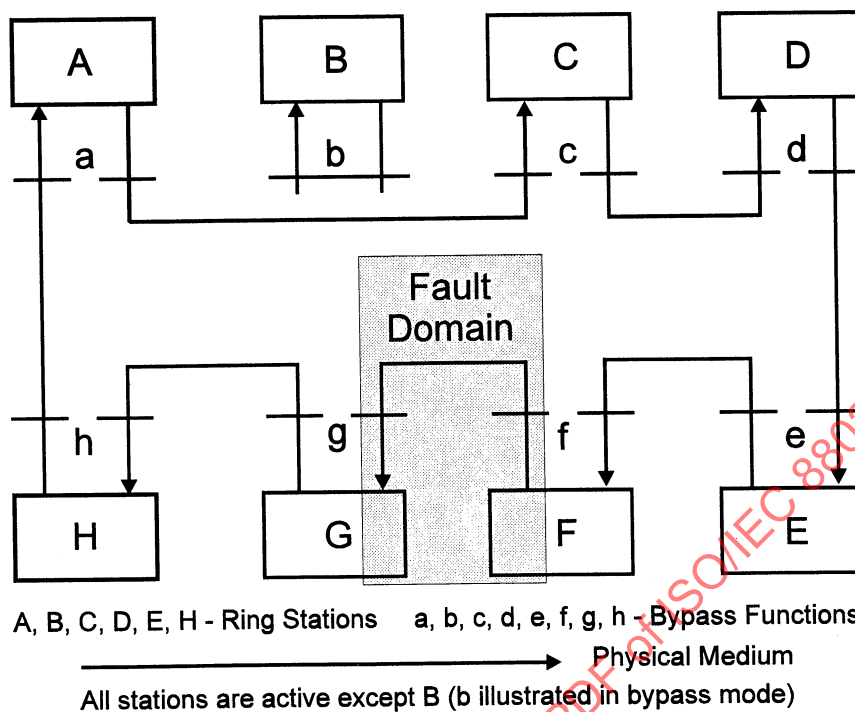

Figure 19—An example of a fault domain

Accurate problem determination is supported by requiring all stations to identify the fault domain when a fault condition is detected. This implies that at any instant in time, each station needs to know the identity of its upstream neighbor station. The Neighbor Notification process (4.1.6.2) provides each station the identity of its upstream neighbor.

#### 4.1.6.2 Neighbor Notification process

The Neighbor Notification process depends on a capability provided by the A bits and the C bits of the FS field. The A and C bits are always transmitted as 0's. If a station recognizes the frame's destination address as a frame it should copy, the station sets the A bits to 1 and, if the station copies the frame, the station sets the C bits to 1.

When a frame is broadcast to all stations on a ring, the first station downstream from the broadcaster is the only station that receives the frame with the A and C bits as 0's. All other stations will see the A bits as 1's since this first station sets the A bits.

The Neighbor Notification process uses this feature by sending the AMP and SMP MAC frames to the broadcast address. If a station receives either of these frames with the A and C bits as 0's, then the frame's SA identifies this station's UNA and this SA is saved as the SUA. If the station is not the active monitor, it then sends a SMP frame to notify its downstream neighbor of its address. This process continues in a circular, daisy-chained fashion to let every station know the identity of its upstream neighbor.

The Neighbor Notification process is performed as follows:

- a) The active monitor begins neighbor notification by broadcasting the AMP MAC frame. The station immediately downstream from it takes the following actions:

- 1) If possible, copies the broadcast AMP MAC frame and, since the A and C bits are 0's, it stores the upstream station's identity as the SUA;
  - 2) Sets the A bits (and C bits if the frame was copied) of the AMP MAC frame to 1's;
  - 3) Resets its timer TQP;
  - 4) Upon expiration of TQP, the station transmits the SMP MAC frame.
- b) One by one, the other stations receive a SMP frame with the A and C bits set to 0's, stores the SUA, resets its TQP timer, and continues the process by broadcasting a SMP frame when its TQP timer expires.
  - c) The active monitor completes the Neighbor Notification process upon reception of an AMP or a SMP MAC frame with its A and C bits set to 0's. If an AMP MAC frame is received with the A and C bits set to 0, then this is a single station ring.

(The AMP MAC frame is sent by the active monitor on a regular basis allowing all other stations (standby monitors) to detect the presence of the active monitor. Each station has a timer TSM that is reset each time an AMP MAC frame is received. If timer TSM expires, the station begins the Ring Recovery process by entering the Claim Token process.

#### 4.1.6.3 Fault Reporting process

The token ring protocol uses two reporting schemes, one for soft errors and one for hard errors. The following explains the handling of hard errors and soft errors using the fault domain illustrated in figure 19.

##### Hard errors:

- a) The token ring protocol uses the Beacon process in an attempt to recover from hard errors and restore normal token operation. If recovery is not possible, the beacon MAC frame identifies the fault domain for analysis by network management functions.
- b) When a hard error is detected between stations F and G, the fault domain is identified and reported by station G transmitting beacon MAC frames. The beacon MAC frame contains the source address of the detecting station (G) and the address of its upstream station (F). This beacon MAC frame allows station (G) to declare the fault domain and alert other stations on the ring that normal token protocol is suspended until the hard error condition terminates or is removed.

##### Soft errors:

- a) The token ring protocol uses either the Ring Purge process or normal token protocol to recover from soft errors and restore normal token operation when necessary.
- b) When a soft error is detected between stations F and G, it is reported by station G, which transmits an Error Report MAC frame containing the source address of the detecting station (G), the address of its upstream station (F), and the count of the errors detected (see 4.1.7). The Error Report MAC frame is sent to the Ring Error Monitor for analysis by network management functions.

#### 4.1.6.4 Ring recovery hierarchy overview

The token ring recovery concept is illustrated in figure 20.

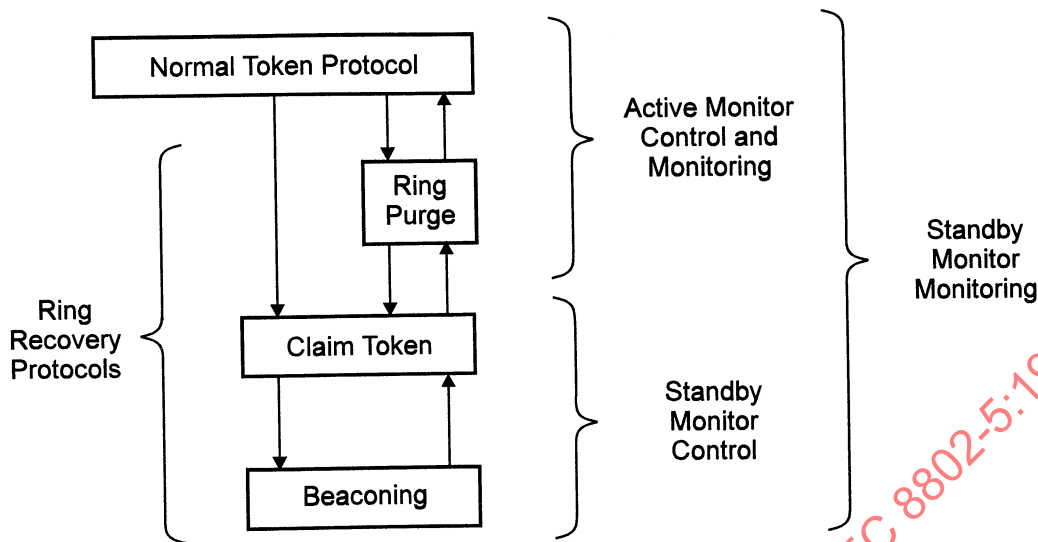

Figure 20—Token ring recovery overview

The token ring recovery concept is a simple one. Once the protocol detects that token passing has been interrupted, the Monitor FSM moves up and down the ring recovery hierarchy without exception as follows:

- a) If a process is successful, the monitor FSM moves up the hierarchy.
- b) If a process fails, the monitor FSM moves down the hierarchy.

Some examples follow:

- a) If the active monitor detects the absence of a token, the Ring Purge process is executed. If the Ring Purge process is successful, the ring returns to normal token protocol operation. If the Ring Purge process fails, the Claim Token process is executed.
- b) If a station detects the absence of an active monitor or that the active monitor is not performing its functions properly, the Claim Token process is executed.
- c) If the Claim Token process is successful, the Ring Purge process is executed. If the Claim Token process fails, the Beacon process is executed.

#### 4.1.6.5 Ring Purge process

The purpose of the Ring Purge process is to clean up the ring and release a token. The Ring Purge process is started when a station wins the Claim Token process (4.1.6.6) and becomes the active monitor or when the active monitor detects a failure in normal token protocol as follows:

- a) There is no token on the ring (i.e., TVX expires without receiving a frame or token);
- b) A station failed to strip its own frame from the ring (frame received with M bit set to 1);
- c) A stacking station failed to lower the priority token that it released (token received with M bit set to 1).

The Ring Purge process is started when the active monitor enters the Transmit Ring Purge state and transmits Ring Purge MAC frames. When the station is not transmitting a Ring Purge MAC frame it is transmitting FILL. The Ring Purge process operates as follows:

- a) Each time the active monitor transmits a Ring Purge MAC frame it resets timer TRR. If TRR expires before the station receives a valid ring purge frame, it transmits another ring purge frame.
- b) If the SA of a received Ring Purge MAC frame does not match the station's MAC address, then the station disables its active monitor functions and returns to normal Repeat state.
- c) When the active monitor receives its own purge MAC frame, it transitions to the normal Repeat state and transmits a token with the priority bits equal to the reservation bits of the received Ring Purge MAC frame and the reservation set to B'000'. If the priority of the token is greater than zero, the active monitor becomes a stacking station (4.1.5).
- d) The active monitor uses the timer TRP to determine if the Ring Purge process fails to complete. Timer TRP is reset when the station first enters the Transmit Ring Purge state. If timer TRP expires while the station is still in Transmit Ring Purge, the station disables its active monitor functions and starts the Claim Token process.

#### 4.1.6.6 Claim Token process

The Claim Token process determines which station becomes the active monitor when the Beacon process (4.1.6.7) is resolved, the Ring Purge process fails to complete, or a station detects that the active monitor functions are not being performed properly.

The Claim Token process is started by a station entering the Transmit Claim Token state and transmitting Claim Token MAC frames. All stations operate as follows:

- a) Stations not in the Claim Token process that receive a Claim Token MAC frame either enter the Repeat Claim Token state or the Transmit Claim Token state as follows.
  - 1) If the station is the active monitor, it enters the Repeat Claim Token state and waits for the Claim Token process to complete. This is an indication that the station has failed to provide proper active monitor functions and should not participate in the Claim Token process nor be an active monitor.
  - 2) If the station is not the active monitor and is not a claim contender (FCCO=0), it enters the Repeat Claim Token state and waits for the Claim Token process to complete.
  - 3) If the station is not the active monitor and is a claim contender (FCCO=1), it compares the source address (SA) of the received claim token MAC frame to its own MAC address and takes the following actions.
    - i) If the received SA is numerically higher than the station's own MAC address, then the station enters the Repeat Claim Token state and waits for the Claim Token process to complete.
    - ii) If the received SA is the same as the station's own MAC address, then the station enters Repeat Claim Token state and waits for the Claim Token process to complete. This is an indication that there is another station on the ring with the same MAC address.
    - iii) If the received SA is numerically lower than the station's own MAC address, then the station enters the Transmit Claim Token state, transmits Claim Token MAC frames, and waits for the reception of either its own Claim Token MAC frame or a Claim Token MAC frame with a higher address.
- b) Stations in Repeat Claim Token state do not take any recovery action on received claim token MAC frames.
- c) Stations in Repeat Claim Token state receiving a Ring Purge MAC frame move to normal token protocol by entering the normal Repeat state.

- d) Stations in the Repeat Claim Token state or the Transmit Claim Token state receiving a beacon MAC frame move to the Beacon process by entering the Repeat Beacon state.
- e) All stations in the Claim Token process use the timer TCT to determine if the Claim Token process fails to complete. Timer TCT is reset when the station first enters either the Repeat Claim Token or the Transmit Claim Token state. If timer TCT expires while the station is still in one of these states, the station starts the Beacon process by entering the Transmit Beacon state and transmitting beacon MAC frames.
- f) Stations in Transmit Claim Token state transmit fill when they are not transmitting a claim token MAC frame and do not repeat frames. Claim Token MAC frames are transmitted without waiting for a token and the timer TQP is used to pace the transmission of the Claim Token MAC frames. When more than one station is in Transmit Claim Token state, a station does not receive its own Claim Token MAC frames.
- g) When a station in Transmit Claim Token state receives a Claim Token MAC frame, it compares the source address (SA) of the received Claim Token MAC frame to its own MAC address and takes the following actions:
  - 1) If the received SA is numerically higher than the station's own MAC address, then the station enters Repeat Claim Token state and waits for the Claim Token process to complete.
  - 2) If the received SA is numerically less than is station's own MAC address, then the station remains in Transmit Claim Token state.
  - 3) If the received SA is the same as the station's own MAC address and the UNA reported in the claim token MAC frame does not match the station's SUA, then the station enters the Repeat Claim Token state and waits for the Claim Token process to complete. The frame's UNA not matching the station's SUA is an indication that there is another station on the ring with the same MAC address.
  - 4) If the received SA is the same as the station's own MAC address, the UNA reported in the claim token MAC frame matches the station's SUA, and the M bit is set to 1, then the station remains in the Transmit Claim Token state. The M bit being set to 1 indicates another station is still functioning as the active monitor.
  - 5) If the received SA is the same as the station's own MAC address, the upstream neighbor's address reported in the claim token MAC frame matches the station's stored upstream neighbor's address, and the M bit is not set, then the station wins the Claim Token process and starts the Ring Purge process.

A station may require multiple receptions of its own claim token MAC frames before winning the Claim Token process. Requiring multiple Claim Token MAC frames to be sent and received prevents a station from winning claim token prematurely and allows time for other stations to enter the Transmit Claim Token state and transmit its Claim Token MAC frames.

Following the rules stated above eventually all stations enter the Repeat Claim Token state except for the one in Transmit Claim Token state with the highest MAC address. The last station remaining in the Transmit Claim Token state receives its own claim token MAC frames and wins the Claim Token process. This station transitions to Transmit Ring Purge state and becomes the new active monitor. The other stations upon receiving the Ring Purge MAC frame, transition from Repeat Claim Token state to normal Repeat state.

A Claim Token MAC frame sent by one station is not repeated by another station in the Transmit Claim Token state. Therefore, only one station in the Transmit Claim Token state enters the Repeat Claim Token state per frame transmission. Claim Token MAC frames are typically paced at 20 ms intervals. To help speed up the Claim Token process and prevent stations in Repeat Claim Token from prematurely entering

the Beacon Transmit state, an option allows a station in Transmit Claim Token state that receives a Claim Token MAC frame resulting in the station entering the Repeat Claim Token state, to transmit the received Claim Token MAC frame (using the SA of the original station).

#### 4.1.6.7 Beacon process

The Beacon process is started by the failure of the Claim Token process (4.1.6.6). The Beacon process relies on the beacon MAC frame and its Beacon Type subvector. At the time the Claim Token process fails, the value of the Beacon Type subvector is determined by examination of the flag, signal loss (FSL) and the flag, claim token (FCT). The following is an explanation of each Beacon Type used in the Beacon process.

**Beacon Type 1:** Only stations implementing the Dual Ring protocol as specified in IEEE 802.5c [B5] generate beacon type 1 frames. Since Beacon Type 1 is the highest priority beacon type, stations not implementing the Dual Ring protocol will not interfere with the IEEE 802.5c protocol.

**Beacon Type 2:** The station is detecting a long-term loss of signal (flag FSL is 1). An example of a Beacon Type 2 condition is a break in the medium between the station and its upstream neighbor.

**Beacon Type 3:** The station has not received any Claim Token MAC frames (flag FCT is 0) but is not detecting loss of signal (flag FSL is 0). The Beacon Type 3 indicates bit streaming (data received does not correspond to expected protocol). An example of a Beacon Type 3 condition is when the upstream station is stuck transmitting fill.

**Beacon Type 4:** The station has received Claim Token MAC frames (flag FCT is 1) and is not detecting a loss of signal (flag FSL is 0). The Beacon Type 4 indicates a station streaming Claim Token MAC frames. An example of a Beacon Type 4 condition is when the upstream station is stuck transmitting Claim Token MAC frames.

All stations in the Beacon process operate as follows:

**Beacon transmit:** The station downstream from the fault enters the Transmit Beacon state by transmitting beacon MAC frames that contain the reason for beaoning (Beacon Type) and the address of its last known upstream neighbor (UNA). Stations in the Transmit Beacon state transmit fill when they are not transmitting a beacon MAC frame and do not repeat frames. When more than one station is in the Transmit Beacon state, a station does not receive its own beacon MAC frames. Beacon frames are transmitted without waiting for a token and the timer TQP is used to pace the transmission of the beacon frames.

- a) If a station in the Transmit Beacon state receives its own beacon frame, then the Beacon process is resolved and the station enters the Claim Token process.
- b) If a station in the Transmit Beacon state receives a beacon frame from another station with an equal or a lower Beacon Type then the station enters the Repeat Beacon state.

When a station first enters the Transmit Beacon state, it resets the TBT timer. When timer TBT expires the station enters Beacon Test state, removes itself from the ring, and performs a test to verify that it is not the source of the fault.

**Beacon receive:** A station not in Transmit Beacon state that receives a beacon frame either enters the Repeat Beacon state or removes itself from the ring. This procedure eventually causes all stations downstream from the station in Transmit Beacon (downstream to the fault) to enter the Repeat Beacon state.

The Beacon process requires a station that has recently joined the ring and has not yet become known to the stations on the ring (not completed the Neighbor Notification process), to remove from the ring when it

either receives a beacon frame or detects a fault condition that would otherwise require it to start the beacon process. This preserves the fault domain established by the last Neighbor Notification cycle. The beacon frame contains the address of the last known upstream neighbor of the beaconing station (UNA). Each station that receives a beacon frame compares the UNA against its own address. Counter CBR is used to count the number of beacon frames which contain an UNA equal to the station's individual address. When the station has received 8 beacon frames in succession with UNA matching its own address (excluding frames with Beacon Type 1), it enters the Beacon Test state, removing itself from the ring, and performing a test to verify that it is not the source of the fault. Since beacon frames are typically paced at 20 ms intervals, this happens within 140–160 ms after receiving the first beacon frame directed at the station. Beacon Type 1 frames are used by dual ring stations during reconfiguration and are excluded from the Beacon Test process.

If a station in Repeat Beacon state receives a claim token MAC frame, the station moves to the Claim Token process entering either the Transmit Claim Token state or the Repeat Claim Token state.

**Monitoring functions:** The Beacon process contains two monitoring functions: 1) Detecting the absence of beacon MAC frames, and 2) optionally detecting a circulating beacon MAC frame.

- a) All stations have a timer TBR that is reset each time a beacon frame is received. If TBR expires, it indicates that no beacon frames are being transmitted and causes the station to start the Claim Token process and enter the Transmit Claim Token state.
- b) The downstream station from the beacon transmitter is responsible for monitoring for circulating beacon frames. The counter CBC is used to invoke this function. The counter CBC is set to its initial value when it first enters the Repeat Beacon state and anytime that it receives a beacon frame that was not transmitted by the station's upstream neighbor as determined by the comparison of the frame's SA with the station's stored upstream neighbor's address (SUA). Each time a frame is received that was transmitted by the station's last known upstream neighbor, counter CBC is decremented. When counter CBC reaches zero, the station will inspect and set the M bit in received frames. If the station downstream from the station transmitting the beacon frames receives a frame with the M bit set, the station starts the Claim Token process by entering the Transmit Claim Token state. This prevents a beacon frame transmitted by a station that has removed from continuously circulating around the ring.

#### 4.1.7 Error reporting

When a station detects an error condition on the ring (such as an FCS error, a lost token, or a lost frame), it increments the appropriate error counter (see 3.6). The expiration of the error report timer (TER) causes the station to report the value of the error counters to the Ring Error Monitor (REM) using the Error Report MAC frame (which also identifies the fault domain—see 4.1.6.2) and the error counters are reset. Persistent errors can be detected, isolated, and, if required, necessary action can be taken by management.

#### 4.1.8 Administration of ring parameters

Upon insertion into the ring, a station requests the value of the various ring operating parameters from the Ring Parameter Server (RPS) to assure compatible operation among stations on the ring. If a RPS is not on the ring, the station uses its default value for TER.

#### 4.1.9 Configuration control

As part of the function of maintaining the configuration of the ring, stations notify the Configuration Report Server (CRS) when they detect a change in the address of their upstream neighbor (detected during the Neighbor Notification process). This indicates that either a station has been inserted into or removed

from the ring. The CRS can alter the configuration of the ring by requesting stations to remove themselves from the ring. The CRS can also query ring stations for various status information.

#### 4.1.10 Early token release (ETR)

The ETR option increases available bandwidth and improves the data transmission efficiency of the token ring protocol when the frame is shorter than the ring latency. ETR allows a transmitting station to release a token as soon as it completes frame transmission, whether or not the frame header has returned to the station. The priority used for tokens released prior to receiving the frame's header will be derived from the priority and reservation of the most recently received frame or token (see priority operation).

It should be noted that the access delay for priority traffic may increase when an ETR system is heavily loaded with short frames. Short frames may impede the effect of priority reservations, since a short frame may be transmitted in its entirety and the next token released before the frame's header returns to the originating station with the ring's reservation.

Stations implementing ETR option are compatible and interoperable with stations that do not. An enhanced stripping algorithm is required to support early token release (see 4.1.3). This algorithm was not specified in previous versions of this standard, which only specified 4 Mbit/s operation; therefore, early token release is only specified for operation at 16 Mbit/s.

#### 4.1.11 Repeat path

The MAC controls when the station repeats data received from the channel. The received data is repeated at the station's output except for the following circumstances (see 5.1.2.2 and 5.1.2.4).

- a) When modification of bits in the AC, ED, and FS fields of a repeated frame or token is necessary
- b) During ring recovery
- c) Transmission of a frame
- d) Transmission of a token
- e) Burst error correction (described in clause 5)

Modification of bits in the repeated frame or token involve

- a) *Setting the M bit.* When stations originate frames or tokens, they transmit the M bit in the AC field as B'0'. The active monitor will set the M bit in the AC field to B'1' as specified in 4.3. All other stations repeat the M bit as received.
- b) *Setting the R bits.* When stations originate frames, they transmit the R bits in the AC field as B'000'. When stations release tokens, the R bits are set as specified in 4.3. When the station has a frame to transmit, the station modifies the reservation bits in the AC field in a repeated frame or token as specified in 4.3 in order to request a token at the appropriate priority.
- c) *Setting the E bit.* When stations originate frames or tokens, they transmit the E bit in the ED as B'0'. The station sets the E bit in the ED as specified in 4.3 when it detects an error in the frame or token.
- d) *Setting the A bits.* When stations originate frames, they transmit both A bits in the FS field as B'0's. The station repeating the frame sets both A bits in the FS field to B'1's as specified in 4.3 when it detects that the frame is valid and addressed to the station.
- e) *Setting the C bits.* When stations originate frames, they transmit both C bits in the FS field as B'0's. The station repeating the frame sets both C bits in the FS field to B'1's as specified in 4.3 when it detects that the frame is valid, the frame is addressed to the station, and the station successfully copies the frame.

During Ring Recovery and Normal Transmission of a frame, the flag FTI is used to control the repeat path [see 5.1.2.4 PS\_CONTROL.request(Repeat\_mode)] such that when FTI=1, the received data is not repeated and fill is transmitted:

- a) During certain phases of ring recovery, the flag FTI is set to 1 to prevent the station from repeating the received data. During recovery, frames are transmitted without waiting for a token. The flag FTI is temporarily set to 0 to allow the frame to be transmitted, and then set back to 1 until either another frame is transmitted or the Monitor state returns to repeat at which time the FTI flag is set to 0 to enable the repeat path.
- b) Capturing a token for transmission involves repeating the SD and P bits of the AC field of the token as received. Starting with the T bit the station stops repeating the token. The station changes the T bit to B'1', sets M to B'0', sets R to B'000', and appends the frame to the end of the AC field (starting with the FC field). After the station has transmitted the frame, flag FTI is set to 1 and the station continues to strip (not repeat) until the FTI flag is set to 0. The station will return to repeating when it
  - 1) Completely receives all of the frames it had transmitted,
  - 2) Detects that another station's frame is being received, or
  - 3) Timer TRR expires indicating a transmitted frame was lost.

During transmission of a token (TX\_TK), a station releases a token at its output independent of the value of the FTI flag. A token is released when

- a) The station releases a token after capturing a token and transmitting its frames.
- b) The active monitor creates a token after purging the ring.
- c) A priority stacking station lowers the ring priority. The exact mechanism to lower the ring priority is not specified. Different mechanisms have been used to lower the priority of the ring. These mechanisms are as follows:
  - 1) The station changes the old token into an abort delimiter and (after a short delay) creates a new token.
  - 2) The station changes the old token into a start-of-frame sequence and then (after a short delay) creates a new token.
  - 3) The station removes the old token and (after a short delay) creates a new token.
  - 4) The station modifies the AC field as it repeats the token.

The Non-data\_J and Non-data\_K symbols are only transmitted in pairs and only with the Non-data\_J symbol transmitted first. This limits the maximum number of signal elements consecutively transmitted at the same level to 3. When the station detects 4 consecutive elements at the same level, Burst4\_error is indicated to the MAC protocol. If more than 4 consecutive elements are received at the same level, Burst5\_error is indicated to the MAC protocol and transitions are introduced into the repeated data after the fourth element and the station continues generating transitions until a transition is received (as specified in clause 5). The first station downstream from a signal interruption will detect the Burst5 error condition. The other stations will receive and repeat the burst4. Note that certain physical characteristics may cause a Burst4 repeated by one station to be detected as a Burst5 at the next.

#### 4.1.12 Assured delivery process

The MAC protocol supports assured delivery on Report Error MAC frames, Report SUA Change MAC frames, and Request Initialization MAC frames to guarantee that the MAC frame is received by its destination. The protocol uses the values of the E, A, and C bits as indicated below to decide if the frame is to be retransmitted.

When the station generates a Report Error frame to the Ring Error Monitor (REM) or a Report SUA Change frame to the Configuration Report Server (CRS), it relies on the value of the E, A, and C bits to indicate if the frame was successfully copied. When the frame is first queued for transmission, a counter (CER or CSC) is reset. When the frame returns to the station, the frame status is examined and the station takes the following actions:

- a) If the frame fails to return to the station, the frame is re-queued.
- b) If the frame status indicates that the frame was copied (C bits set) then the process terminates.
- c) If the frame status indicates that the frame was good (E bit not set) and the server does not exist (A bits not set), then the process terminates.
- d) If the counter reaches its terminal count (typically 4 tries), the process terminates.
- e) If the status indicates that the server did not copy the frame (C bit not set) but either the server was present (A bit set) or the frame had an error (E bit set), then the frame is re-queued and the counter is incremented.

During the Join process, the station generates Request Initialization frames to the Ring Parameter Server (RPS). This process uses 2 counters (CRI & CRIN). The counter CRIN is used to determine that no RPS exists on the ring. When the RPS does exist on the ring, the timer TRI is used to pace the request frames and the counter CRI limits the number of request frames transmitted. When the first Request Initialization frame is queued, CRI, CRIN, and TRI are reset. When the frame returns to the station, the frame status is examined. The station takes the following actions:

- a) If the frame fails to return to the station, then another request frame is queued.
- b) If the frame had an error (E bit set), then another request frame is queued.
- c) If the frame status indicates that the server does exist (A bits set) then the timer TRI is reset.
- d) If the frame status indicates that the server does not exist (A bits not set), then counter CRIN is incremented, and if CRIN has not reached terminal count, another request frame is queued.
- e) If the counter CRIN reaches terminal count (typically 4 tries) then the server does not exist and the process terminates.
- f) If the station receives an Initialize Station MAC frame or a Change Parameters MAC frame, the process terminates.
- g) If the timer TRI expires before an appropriate response frame is received, then CRI is incremented and, if CRI has not reached terminal count, another request frame is queued.
- h) If the counter CRI reaches terminal count (typically 4 tries), then there is a failure to communicate and the Join process fails.

#### 4.1.13 MAC service interfaces

The LLC, Bridge, and management interfaces are specified to provide the service required by other standards. These interfaces serve to specify operation and do not imply any particular implementation.

##### 4.1.13.1 Service to LLC

On receipt of a MA\_UNITDATA.request primitive from the local LLC entity, the MAC shall compose a frame using the parameters supplied to create the FC, DA, SA, RI (if present), INFO (user data) fields and calculates the FCS field. The RII bit shall be set to 1 if and only if routing information is present. The User\_priority parameter establishes the requested access priority (Pm) of the frame and is also encoded in the YYY bits of the FC field. The value of the YYY bits shall be either the value of the User\_priority parameter or may optionally be set to B'000'. It is recommended that the value of Pm be set to the value of the User\_priority parameter. Annex I provides recommendations on the use of access priorities. The frame is then queued for transmission on a suitable token.

If a valid LLC frame is received with a DA that matches the station's individual address, matches one of the station's group addresses, matches an active functional address, or matches one of the broadcast addresses, then a MA\_UNITDATA.indication is made to the local LLC entity. The value of the User\_priority parameter shall be equal to the value of the YYY bits in the FC field.

#### 4.1.13.2 Service to the bridge

On receipt of a M\_UNITDATA.request primitive from the local bridge entity, the MAC shall compose a frame using the parameters supplied to create the FC, DA, SA, RI (if present), INFO (user data), and FCS fields. The RII bit shall be set to 1 if and only if routing information is present. The Access\_priority parameter establishes the requested access priority (Pm) of the frame and User\_priority parameter is encoded in the YYY bits of the FC field. If the FCS parameter is not specified, then the station calculates the FCS value. It is recommended that the value of Pm be set to the value of the Access\_priority parameter. Annex I provides recommendations on the use of access priority. The frame is then queued for transmission on a suitable token.

When a valid frame is received (independent of any address match), a M\_UNITDATA.indication is made to the bridge entity. If the frame type is LLC then the value for the User\_priority parameter shall be the value of the YYY bits in the FC field, otherwise the value for the User\_priority parameter is unspecified.

#### 4.1.13.3 Service to management

On receipt of a MGT\_UNITDATA.request primitive from the local management entity, the MAC shall compose a MAC frame using the parameters supplied to create the FC, DA, SA, RI (if present), and INFO (vector) fields, MAC information field, and calculated FCS field. The RII bit shall be set to 1 if and only if routing information is present. The requested access priority (Pm) of the frame shall be the value of the Access\_priority parameter. The frame is then queued for transmission on a suitable token.

If a valid MAC frame with a non-zero destination class is received with a DA that matches the station's individual address, one of the group addresses, an active functional address, or one of the broadcast addresses, then a MGT\_UNITDATA.indication is made to the MGT entity.

## 4.2 Specification definitions

The MAC protocol is specified in 4.3.4 as a table of events and actions. There are three basic state machines contained within the MAC protocol. They are the Join State Machine, the Monitor State Machine, and the Transmit State Machine. High level state machine diagrams are presented in figures 23, 24, and 25 as an overview of how the three state machines operate. A detailed set of state diagrams are presented in annex F.

This clause explains the notation used in the finite-state machines (FSM), provides an overview of the Join Ring, Monitor, and Transmit FSMs, provides a list of abbreviations used, and defines the flags and counters used in the FSMs and Station Operation tables.

### 4.2.1 Finite state machine (FSM) notation

The notation used in the FSM diagrams is illustrated in figure 21.

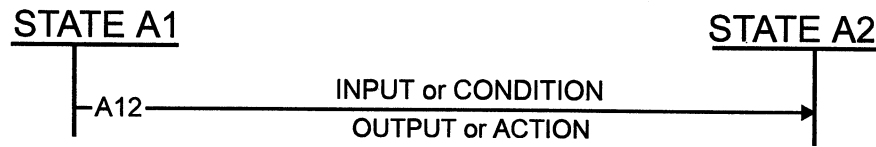

**Figure 21—Sample FSM notation**

States are shown as vertical lines. Transitions are shown as horizontal lines numbered with a letter representing the state machine and a two-digit number where the first digit represents the starting state and the second digit represents the ending state. For example, A12 indicates the transition from state 1 to state 2 of state machine A. Where there is more than one transition between any two states, a suffix is added to differentiate the transitions (e.g., A12a and A12b). The arrow indicates the direction of transition.

The inputs or conditions shown above the line are the requirements for making the transition. The output or action shown below the line occurs simultaneously with making the transition. The transition begins when the input occurs or the specified condition is met and is complete when the output or action has occurred. If the state transition is in progress, then no other FSM transition may be initiated.

If the conditions for transition out of a state are satisfied at the time the state is entered, no action is taken in that state and the exit transition is taken immediately.

The Station Operation table is an abstract model of the Token Ring Station protocol machine. For all possible combinations of events and station states it determines an unambiguous and consistent response by the station, including next state and primitives at the various service interfaces.

The Station Operation table and FSMs are evaluated as follows:

- a) A snapshot of the value of all event terms is taken at an instant in time.
- b) All event statements are evaluated as TRUE or FALSE, depending on the truth of each element in the event statements.
- c) The actions for all TRUE events are performed.
- d) Actions, except for transmit sequences and clock source changes are considered to occur simultaneously.
- e) Transmit sequences are started and performed in the order specified.

If table 7 indicates that a clock source (FTXC) change will occur while TS=DATA, then the clock source change shall be delayed until TS<>DATA. If table 7 indicates that a clock source change will occur at the same time as a transmit sequence starts, the station may delay the clock source change until after the transmit sequence is complete (TS<>DATA).

The station should delay a transition into TS=DATA by at least 1.5 ms (see 5.7.1) after a clock source change.

- f) Evaluation is repeated beginning with Step 1.

Timer=E events will evaluate as TRUE in the snapshot immediately following expiration of the timer, and are never TRUE in more than one snapshot.

The station must have a way of ordering simultaneous external events which would otherwise cause contradictory actions, for example, simultaneous frame arrival and timer expiration. Except for the case of simultaneous events, the actions associated with the set of TRUE event statements in the FSM and Station Operation table are never contradictory. The method that a station uses to arbitrate simultaneous events is

implementation-dependent and not constrained by this standard. The station may act on simultaneous events in any order prior to considering subsequent events.

Actions do not affect the truth of event statements until the next snapshot.

#### 4.2.2 Join Ring FSM / Monitor FSM / Transmit FSM interaction

This clause and its figures explain the interaction of the Join Ring, Monitor, and Transmit FSMs. Functions performed by the FSMs are defined in 4.3. The Join Ring FSM is parent to the Monitor FSM which is parent to the Transmit FSM. Figure 22 illustrates the interaction of the Join Ring, Transmit, and Monitor FSMs.

The following FSM starting conditions (i.e., power on) are assumed:

- a) Counters are set to 0.
- b) Event Flags are set to 0.
- c) Station Policy Flags are set according to station policy.
- d) Timers are not running (stopped).

**BYPASS.** This state is entered as the result of station power-on-reset or as the result of detection of errors by the Join Ring or Monitor FSMs that cause the station to remove itself from the ring. The Transmit and Monitor FSMs are not specified while in the Join Ring bypass state (J0).

##### 4.2.2.1 Join Ring FSM overview

The Join Ring FSM diagram is shown in figure 23. The Join Ring FSM always begins in BYPASS (J0). When the Connect.MAC request is detected, a Lobe Test is performed. During Lobe Test (JS=LT), the Monitor FSM is suspended and the station assumes it is the only entity on the lobe capable of putting data on the lobe. If the Lobe Test completes successfully, the Transmit and Monitor FSMs are activated in states TS=RPT and MS=RPT and the station requests insertion<sup>7</sup> into the ring. After requesting insertion, the Join Ring process will first determine if an active monitor exists on the ring. If no active monitor exists, the Monitor FSM is instructed to enter the Claim Token process. Once an active monitor exists, the DAT is performed to assure that the station's individual address is unique. Until the address has been verified, the station is not allowed to participate in the Neighbor Notification process. Once the address has been verified, the station is required to participate.

The last phase of the Join sequence is to request the station's ring parameters from the Ring Parameter Server (RPS). Once the join sequence is complete, the flag FJR is set. Depending on the FBHO policy flag, the FINS flag will be set to 1 either after the Neighbor Notification process has been completed, or after ring parameter initialization. Setting the FINS flag indicates that the station will participate in the token-ring recovery protocols and report ring errors.

The exact functions performed by the Join Ring FSM are specified in 4.3.4.

<sup>7</sup> The MAC protocol expects the TCU to insert the station into the ring when ring insertion is requested. The concentrator's management may direct the TCU not to insert the station into the ring. The MAC protocol may be unable to detect that the concentrator's management has denied station insertion into the ring. When this occurs, the MAC continues operation as a single station ring, yet higher layer protocols will not be able to establish peer-to-peer connections.

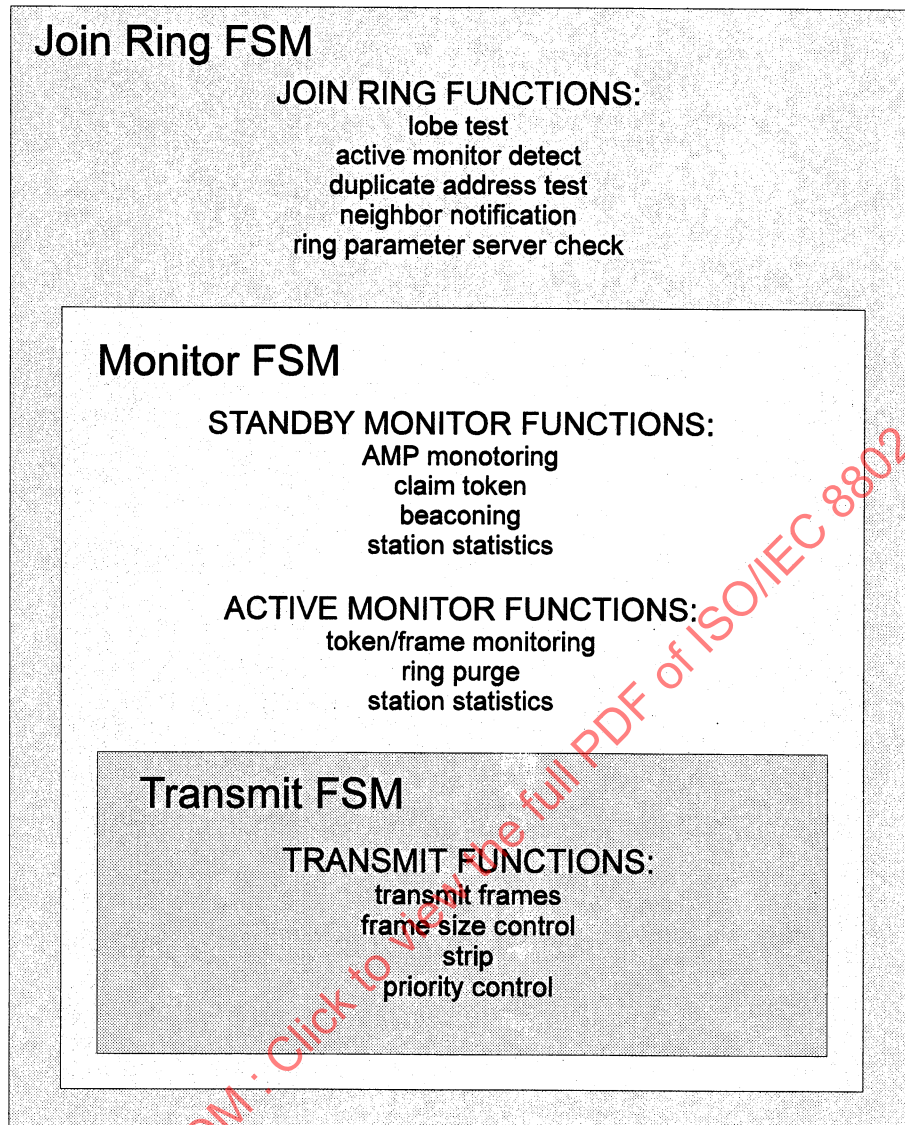

Figure 22—Join Ring, Transmit, and Monitor FSM interaction

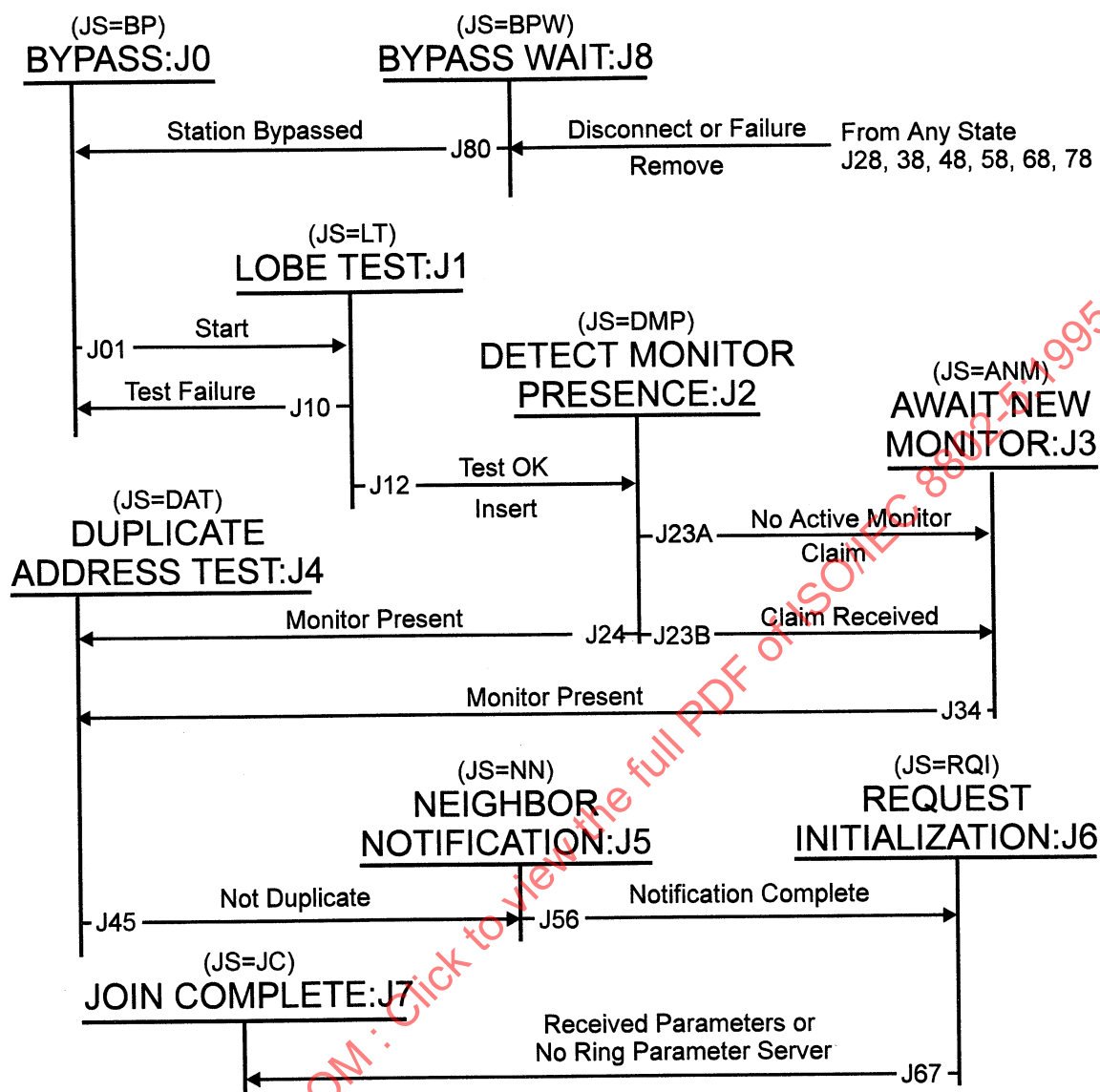

Figure 23—Join Ring FSM diagram

#### 4.2.2.2 Transmit FSM overview

The Transmit FSM diagram is shown in figure 24. The transmit FSM is used to transmit frames following the token capture rules. The Transmit FSM captures a token, transmits the frame(s), strips the frame(s) from the ring, provides fill if necessary, and releases a correct token according to the rules of priority and early token release.

The purpose of recovery is to bring the ring back to a point at which a token can circulate the ring and thus allow stations to capture the token and transmit their frames. The reception of a token while in ring recovery is an unexpected event. A station is not required nor is it prevented from transmitting queued frames during recovery if a token is received.

The exact functions performed by the Transmit FSM are specified in the Station Operation tables (clause 4.3).

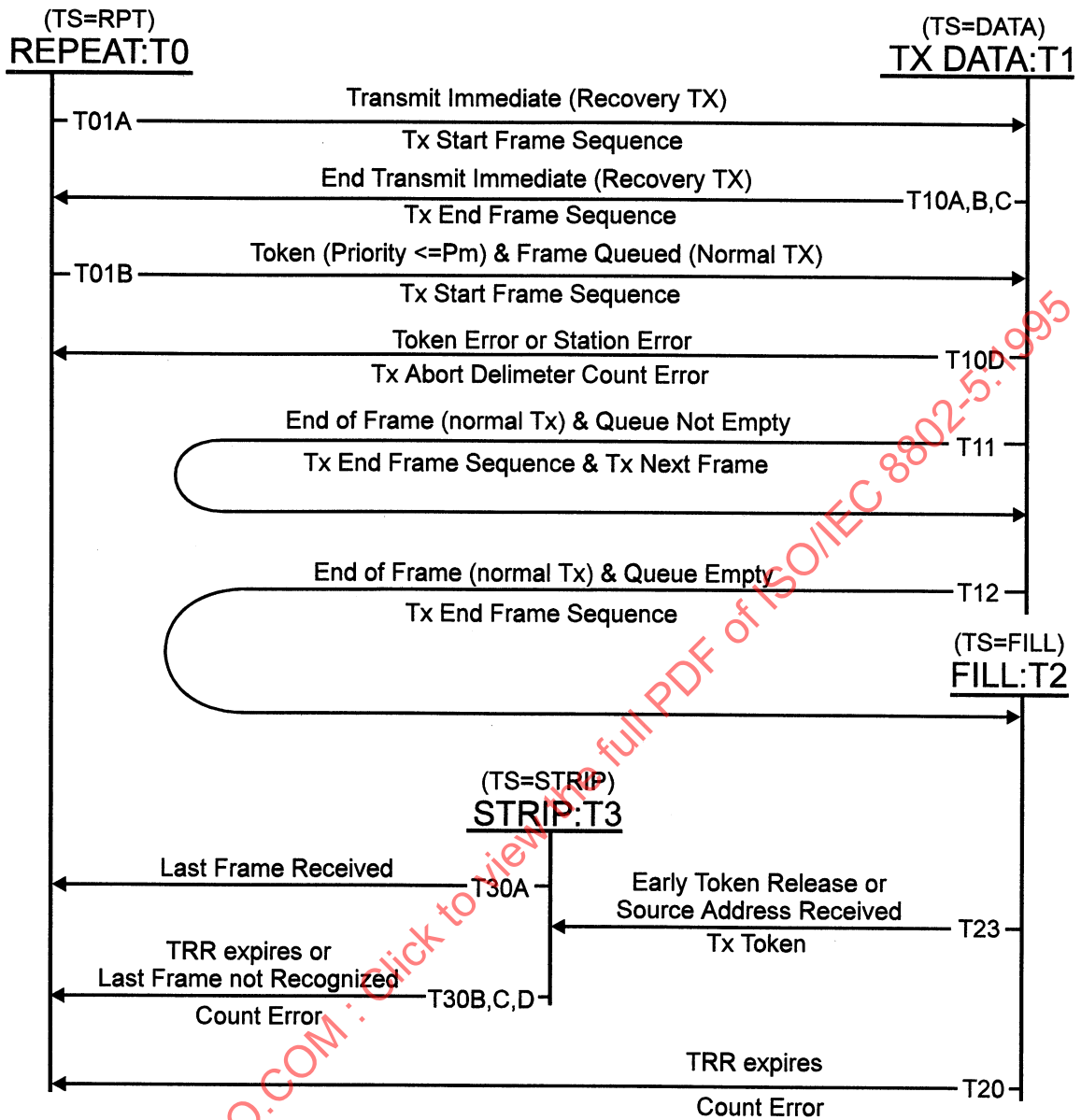

Figure 24—Transmit FSM diagram

#### 4.2.2.4 Monitor FSM overview

The Monitor FSM is shown in figure 25. The Monitor FSM provides both the Standby Monitor and Active Monitor functions.

- a) The Standby Monitor functions include monitoring of the active monitor, claiming to establish an active monitor, and beaconing to recover from ring faults.
- b) The Active Monitor functions include token/frame monitoring to assure ring utilization and ring purge to recover from the loss of a valid token.

During normal token-ring operation, the Active Monitor functions are active in ONLY ONE station on the ring and the Standby Monitor functions are active in ALL other stations on the ring. However, during the claim token and beacon operations, ALL stations are using their Standby Monitor Functions.

The Monitor FSM shown in figure 25 has three states in which the station repeats received data: 1) Normal Repeat (MS=RPT), 2) Repeat Claim Token (MS=RCT), and 3) Repeat Beacon (MS=RBN).

- a) In the normal repeat state, the station is monitoring the ring's normal protocol operation.
- b) In the repeat claim token or repeat beacon states, the station is not actively participating in ring recovery (that is, not transmitting a Ring Purge, Claim Token, or Beacon MAC frame). Instead the station is monitoring the ring for correct claim token and beacon operation.

When the Monitor FSM is not in one of these repeat states, the station is either transmitting one of the recovery frames or testing itself and does not repeat data. Frames received are examined to determine FSM's actions. When testing itself, the station is not inserted in the ring.

The exact functions performed by the Monitor FSM are specified in table 7.

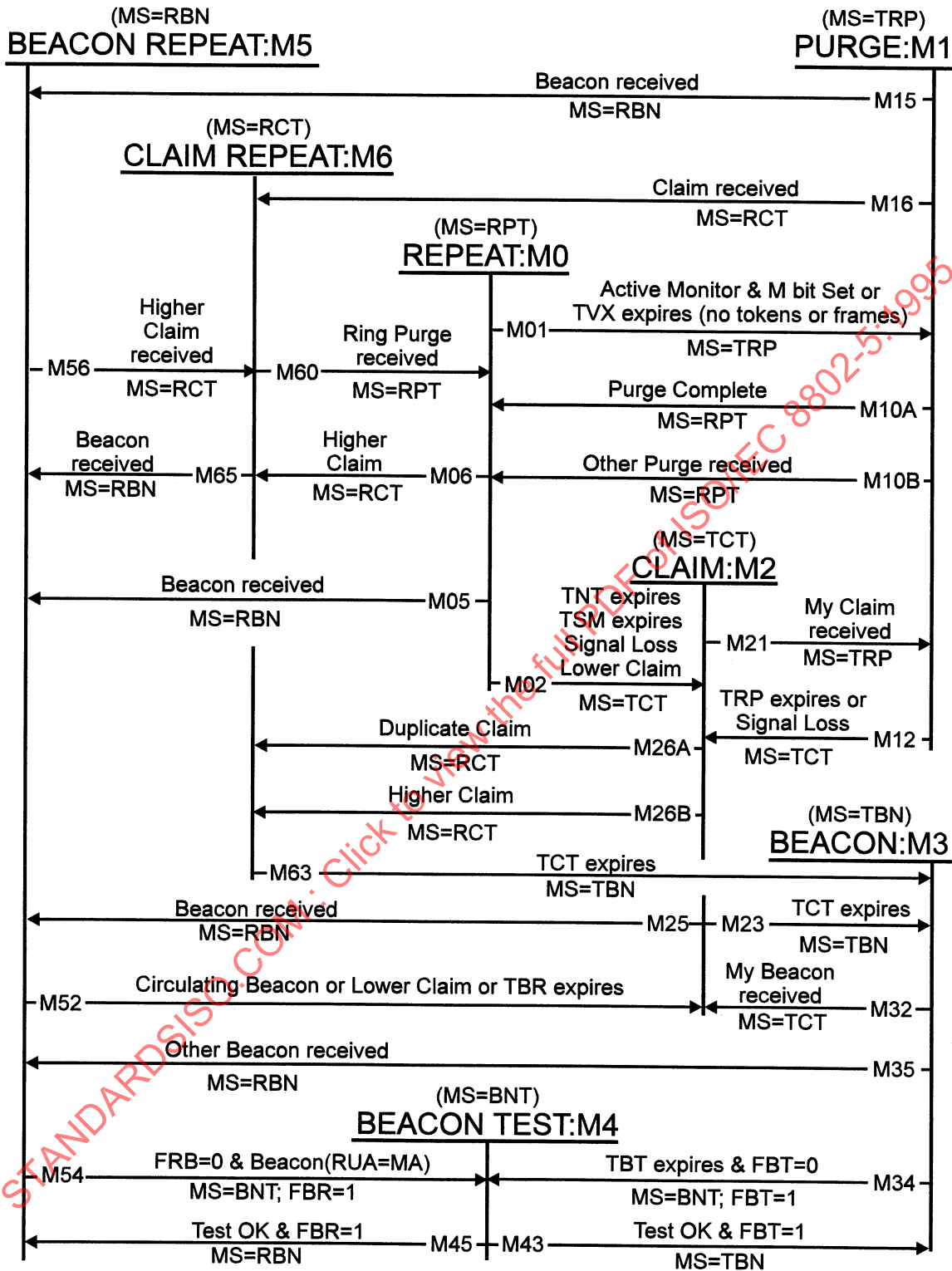

Figure 25—Monitor FSM diagram

### 4.2.3 Abbreviations and notations

The following list contains abbreviations and notations used in table 7 and in state machine descriptions.

#### Station policy flag notations

FBHO	=	Flag, beacon handling option
FCCO	=	Flag, claim contender option
FETO	=	Flag, early token release option
FECO	=	Flag, error counting option
FGTO	=	Flag, good token option
FMFTO	=	Flag, multi-frame transmit option
FMRO	=	Flag, medium rate option
FRRO	=	Flag, reject remove option
FTEO	=	Flag, token error option
FTHO	=	Flag, token handling option

#### MAC protocol flag notations

FAM	=	Flag, active monitor
FANM	=	Flag, await new monitor
FAT	=	Flag, any token received
FBR	=	Flag, repeat beacon test
FBT	=	Flag, transmit beacon test
FCT	=	Flag, claim token
FDC	=	Flag, duplicate address test complete
FED	=	Flag, ending delimiter
FER	=	Flag, error report required
FID	=	Flag, insert delay
FINS	=	Flag, inserted
FJR	=	Flag, join ring process complete
FLF	=	Flag, lost frame
FMA	=	Flag, my address received
FMP	=	Flag, monitor present
FNC	=	Flag, neighbor notification complete
FNMA	=	Flag, not my address received
FNN	=	Flag, neighbor notification
FNW	=	Flag, neighbor notification waiting
FOP	=	Flag, operational
FPT	=	Flag, priority token
FRH	=	Flag, remove hold
FSL	=	Flag, signal loss
FSLD	=	Flag, signal loss detected
FSD	=	Flag, starting delimiter
FSMP	=	Flag, standby monitor present
FTI	=	Flag, transmit idles
FTW	=	Flag, test wait
FTXC	=	Flag, crystal transmit
FTXI	=	Flag, transmit immediate
FWF	=	Flag, wire fault
FWFA	=	Flag, wire fault active

#### Counter notations

CABE	=	Counter, abort error
CACE	=	Counter, AC error
CBC	=	Counter, beacon circulating

CBE	=	Counter, burst error
CBR	=	Counter, beacon repeat
CCR	=	Counter, claim receive
CCT	=	Counter, claim transmit
CDF	=	Counter, DAT failure
CDG	=	Counter, DAT good
CER	=	Counter, error report
CFCE	=	Counter, frame-copied error
CFE	=	Counter, frequency error
CFR	=	Counter, frames (frames to be stripped)
CIE	=	Counter, internal error
CLE	=	Counter, line error
CLFE	=	Counter, lost frame error
CRCE	=	Counter, receive congestion error
CRI	=	Counter, request initialization
CRIN	=	Counter, RQ_INIT not recognized
CNNR	=	Counter, neighbor notification requests
CSC	=	Counter, SUA change
CTE	=	Counter, token error
CTO	=	Counter, transmitted octets

**Timer notations**

TAM	=	Timer, active monitor
TBR	=	Timer, beacon repeat
TBT	=	Timer, transmit beacon test
TCT	=	Timer, claim token
TER	=	Timer, queue error report
TID	=	Timer, insert delay
TJR	=	Timer, join ring
TNT	=	Timer, no token
TQP	=	Timer, queue PDU
TRH	=	Timer, remove hold
TRI	=	Timer, ring initialization
TRP	=	Timer, transmit ring purge
TRR	=	Timer, return to repeat
TRW	=	Timer, remove wait
TSL	=	Timer, signal loss
TSM	=	Timer, standby monitor
TVX	=	Timer, valid transmission
TWF	=	Timer, wire fault
TWED	=	Timer, wire fault delay

**Join state notations (JS=)**

ANM	=	await new monitor
BP	=	bypass
BPW	=	bypass wait
DAT	=	duplicate address test
DMP	=	detect monitor presence
JC	=	join complete
LT	=	lobe test
NN	=	neighbor notification
RQI	=	request initialization

#### Transmit state notations (TS=)

DATA	=	Transmit frame data
FILL	=	Transmit fill and release token
RPT	=	Repeat
STRIP	=	Strip transmitted frames and transmit fill

#### Monitor state notations (MS=)

BNT	=	beacon test
RBN	=	repeat beacon
RCT	=	repeat claim token
RPT	=	normal repeat
TBN	=	transmit beacon
TCT	=	transmit claim token
TRP	=	transmit ring purge

### 4.2.4 State machine elements

The state machines use the following counters, flags, and states to describe the operation of the station. These are logical elements used solely to describe the operation and do not specify an implementation. The value of the flags and counters are only meaningful internal to the state machine definition. Conformance will only be based on the station's ability to perform the protocol as specified by table 7.

#### 4.2.4.1 Counters

Unless otherwise specified, all counters are set to 0 by the "Set\_initial\_conditions" action as the result of the Join Ring FSM transition detecting the Connect.MAC request.

A counter may be set to a value, counted up (incremented), or counted down (decremented) as a result of an action specified in the station operation table.

**Counter, Beacon Circulating (CBC).** The Monitor FSM uses the counter CBC to count the number of beacon MAC frames received from the station's upstream station before activating the circulating beacon frame detection (4.1.6.7).

**Counter, Beacon Repeat (CBR).** The Monitor FSM uses the counter CBR to control the number of beacon MAC frames received from its downstream neighbor before removing itself from the ring and entering the Beacon Test state.

**Counter, Claim Receive (CCR).** The Monitor FSM uses the counter CCR to count the number of Claim Token MAC frames transmitted by this station (MS=TCT) that have been successfully received and thus allow resolution of the Claim Token process.

**Counter, Claim Transmit (CCT).** The Monitor FSM uses the counter CCT to count the number of times the Claim Token MAC frame is transmitted by this station (MS=TCT).

**Counter, DAT Failure (CDF).** The Join Ring FSM uses the counter CDF to count the number of times the DAT MAC frame transmitted by this station is received with A=1. This counter is initialized to 0 by the Join Ring FSM.

**Counter, DAT Good (CDG).** The Join Ring FSM uses the counter CDG to count the number of times the DAT MAC frame transmitted by this station is received with A=0 and C=0. This counter is initialized to 0 by the Join Ring FSM.

**Counter, Error Report (CER).** The counter (CER) is used to control the number of times the Error Report MAC frame will be retransmitted by the assured delivery process.

**Counter, Frame (CFR).** The transmit FSM uses the counter CFR to indicate the number of frames originated by the station which, by station calculation, are still on the ring. Counter CFR is incremented when a SFS is transmitted. After the station has transmitted its first ED (FED=1), CFR is decremented when the ED of a frame (FSD=1) is stripped. This counter is defined for stations that transmit multiple frames per token.

**Counter, Neighbor Notification Requests (CNNR).** The neighbor notification counter counts the number of neighbor notifications since the last ring purge for the purpose of inhibiting counting neighbor notification errors due to normal recovery protocol.

**Counter, Request Initialization (CRI).** The Join Ring FSM uses the counter CRI to limit the number of RQ\_INIT frames transmitted to the ring parameter server that were recognized by the RPS (A bits set).

**Counter, Request Initialization Not recognized (CRIN).** The join ring FSM uses the counter CRIN to limit the number of RQ\_INIT frames transmitted to the ring parameter server that were not recognized by the RPS (A bits not set).

**Counter, SUA Change (CSC).** The counter (CSC) is used to control the number of times the SUA Change MAC frame will be retransmitted by the assured delivery process.

**Counter, Transmitted Octets (CTO).** The counter CTO is used by the Transmit FSM to limit the number of octets that can be transmitted after capturing the token and thus limit the token holding time of the station. Depending on the medium rate, the counter CTO is pre loaded with a value that indicates the maximum number of octets the station may transmit before releasing a token. Once a station has acquired the token, the CTO counter is decremented every 8 symbols (octet). A station may continue to transmit frames smaller than the remaining value of CTO. A frame with a size larger than the remaining value of CTO will be deferred until the next token capture. The maximum octet count values of CTO (based on a token holding time of 9.1 ms) at 4 Mbit/s is 4550 and at 16 Mbit/s is 18 200. A station may support any value for its maximum octet count (MAX\_TX) that does not exceed these maximum octet count values. In addition, a station is not required to transmit more than one frame per token opportunity.

#### 4.2.4.2 MAC protocol flags

Flags are used to remember occurrence of an event for later action by the FSMs and the Station Operation Table (table 7) and are not meant to imply any implementation requirements. In general, a flag is set to 1 when a condition occurs and set to 0 when the condition no longer exists or the appropriate action is taken. All MAC protocol flags (not station policy flags) are set to 0 by the "Set\_initial\_conditions" action of the Join Ring FSM.

NOTE—FTXC and FTI require specific actions when the flags are set.

The following flags, listed alphabetically, are defined:

**Flag, Active Monitor (FAM).** The flag FAM is set to 1 when the station wins the Claim Token process and becomes an active monitor. FAM is set to 0 when the station enters the standby monitor mode.

**Flag, Await New Monitor (FANM).** The flag FANM is only set to 1 when the station is joining the ring and has not detected an active monitor function on the ring. This allows the station to participate in the Claim Token process since it may be the only station on the ring.

**Flag, Any Token (FAT).** The flag FAT is used by a station in its role as Active Monitor (FAM=1). FAT is set to 1 when the station detects a frame or a token. FAT is tested and set to 0 upon expiration of TVX (timer valid transmission).

**Flag, Beacon Repeat (FBR).** The flag FBR is set to 1 when the station enters the beacon test state from the repeat beacon state to prevent multiple entries into the beacon test function and to indicate that the station should return to the repeat beacon state upon successful completion of beacon test.

**Flag, Beacon Test (FBT).** The flag FBT is set to 1 when the station enters the beacon test state from the transmit beacon state to prevent multiple entries into the beacon test state and to indicate the station should return to the transmit beacon state upon successful completion of beacon test.

**Flag, Claim Token (FCT).** The flag FCT is set to 1 upon reception of a claim token MAC frame for the purpose of determining the beacon type subvector (TX\_BN\_TYPE) of the beacon MAC frame when entering the transmit beacon state. FCT is set to 0 when entering the transmit claim token state.

**Flag, Duplicate Address Test Complete (FDC).** FDC is initially set to 0 the first time the station enters the ring as a result of the Join Ring FSM. The flag FDC is set to 1 upon completion of the duplicate address test (JS=DAT) and allows transition to the Neighbor Notification process (JS=NN). The flag FDC is also used by IEEE Std 802.5c-1991 [B5] to indicate whether or not DAT has completed for this MAC. See IEEE Std 802.5c-1991 for more information.

**Flag, Ending Delimiter (FED).** The FED flag is used to synchronize the frame counter (CFR) with the transmission of the first frame (ending delimiter). Flag FED is set to 0 upon entry into the transmit frame data state (in conjunction with the start of transmission of the first frame after token capture). The flag FED is set to 1 upon the transmission of a frame's ending delimiter after token capture thus allowing CFR to be decremented by each received frame's ending delimiter.

**Flag, Error Report (FER).** The flag FER is set to 1 when the first reportable error is detected and indicates that subsequent errors should not reset the error timer TER. Flag FER is set to 0 when the error timer expires and the Report Error MAC frame is transmitted.

**Flag, Insert Delay (FID).** Flag FID is used when returning from the beacon test state to assure sufficient time has elapsed to allow the PHY to insert the station in the ring's data path (no longer wrapped at the TCU). Flag FID is set to 1 causing the station in the repeat beacon state (MS=RBN) or the transmit beacon state (MS=TBN) to wait for a) expiration of timer TID, b) reception of any frame, or c) the detection of filtered signal loss. Once one of these conditions is recognized, flag FID is set to 0 allowing the station to continue with normal resolution of the Beacon process.

**Flag, Inserted (FINS).** Flag FINS is initially set to 0 as a result of the Join Ring FSM. The flag FINS is set to 1 to indicate when the station may participate in beacon functions. A station may activate this capability either at the completion of neighbor notification (JS=NN) or at the completion of request initialization (JS=RQI) depending on the setting of the policy flag FBHO.

**Flag, Join Ring (FJR).** FJR is initially set to 0 as a result of the Join Ring FSM. The flag FJR is set to 1 upon completion of request initialization phase (JS=RQI).

**Flag, Lost Frame (FLF).** Flag FLF is used to count lost frame errors. The flag FLF is set to 1 at the time the station stops stripping if the transmitted frame had failed to return to the station. FLF is set to 0 when the CLFE error counter is incremented.

**Flag, My Address (FMA).** Flag FMA is used to indicate if the frame being stripped is actually the last frame transmitted. Flag FMA is set to 0 upon entry to the transmit frame data state (prior to transmission of the first frame after token capture), when a SD is received, and when an ED is received. When the frame

counter indicates that the last transmitted frame is being stripped (CFR=1), the flag FMA is set to 1 upon receiving a frame with SA that is equal to this station's last transmitted source address.

**Flag, Monitor Present (FMP).** Flag FMP is initially set to 0 as a result of the Join Ring FSM. The flag FMP is used while joining the ring and is set to 1 upon detecting the ring has an active monitor (receipt of a RP, AMP, or SMP frame).

**Flag, Neighbor Notification Complete (FNC).** Flag FNC is initially set to 0 as a result of the Join Ring FSM. The flag FNC is set to 1 upon completion of Join Ring state J5 (JS=NN) indicating neighbor notification has been completed (the station now knows its UNA).

**Flag, Not My Address (FNMA).** The flag FNMA is used to prevent overstripping caused by bit errors during multiple frame transmission and early token release. Flag FNMA is set to 0 upon entry to the transmit frame data state (prior to transmission of the first frame after token capture), when a SD is received, and when an ED is received. When the frame counter indicates that the last transmitted frame is being stripped (CFR=1), the flag FNMA is set to 1 if the SA of the received frame is not equal to the SA of the last frame transmitted. This flag is set to 1 only if the SA is composed of only 0 and 1 bits and the counter CFR is equal to 1. When this flag is set, it indicates the station has started to strip a frame sent from another station and the station returns to repeat allowing the other station to successfully count the ending delimiter. This flag is not required to be set to one if early token release is not implemented (FETO=0) and the station only transmits one frame per token opportunity.

**Flag, Neighbor Notification (FNN).** Flag FNN is only used by the active monitor. FNN is set to 0 when the active monitor starts the Neighbor Notification process. FNN is set to 1 when the active monitor receives an AMP or SMP frame with both the A and C bits set to 0, indicating the Neighbor Notification process has completed. When the active monitor starts a new neighbor notification cycle, the value of FNN indicates if the previous cycle failed to complete. If FNN is already set to 1 when a SMP MAC frame is received with both the A and C bits set to 0, it is considered an error.

**Flag, Neighbor Notification Waiting (FNW).** The station is inhibited from participating in neighbor notification until it has passed the DAT. Prior to DAT completion, Flag FNW is used to remember that the station has received a neighbor notification frame and that its neighbor is waiting. Flag FNW is initially set to 0 as a result of the Join Ring FSM. The flag FNW is set to 1 as the result of the reception of an appropriate AMP or a SMP MAC frame (A=0).

**Flag, Operational (FOP).** The flag FOP indicates when the station is operational. When FOP is set to 0 the station is not required to respond to signals at its receiver input. Flag FOP is initially set to 0 and is set to 1 at the time the station completes Lobe Test (JS=LT) and inserts into the ring. Flag FOP is set to 0 at the time the station removes from the ring (JS=BPW). FOP is also set to 0 when the station removes for testing (MS=BNT) and set back to 1 when the station inserts after successful completion of the beacon test process.

**Flag, Priority Token (FPT).** The flag FPT indicates the presence of a priority token (P>0). If a priority token is received, FPT is set to 1. If a frame or token with P=0 is received, FPT is set to 0.

**Flag, Remove Hold (FRH).** The flag FRH is set to 1 as the result of the Join Ring FSM. The flag FRH is set to 0 to indicate that the station has waited the required minimum time before removing from the ring.

**Flag, Signal Loss (FSL).** The flag FSL indicates the reception, or lack thereof, of valid signal from the ring [see 5.1.4.1, PM\_STATUS.indication(Signal\_detection)]. FSL is set to 1 when loss of signal has occurred for the period of TSL (filtered signal loss). FSL is set to 0 upon detection of valid signal.

**Flag, Signal Loss Detected (FSLD).** The flag FSLD is used to determine whether or not the PHY signal is a steady-state condition. FSLD is set to 0 upon receiving PM\_STATUS.indication

(Signal\_detected=Signal\_acquired), thus making the signal loss detection process inactive. FSLD is set to 1 upon receiving PM\_STATUS.indication( Signal\_detected=Signal\_loss). When FSLD is set to 1, the signal loss detection process is active.

**Flag, Standby Monitor Present (FSMP).** Flag FSMP is only used by standby monitors. The flag FSMP is used to detect neighbor notification failures that would cause excessive neighbor notification frames. FSMP is set to 0 upon reception of an AMP MAC frame with the A and C bits not equal to 0 (indicating the start of a neighbor notification cycle). FSMP is set to 1 by the standby monitor upon receiving a SMP MAC frame with both the A and C bits set to 0, or an AMP MAC frame with both the A and C bits set to 0. If a subsequent SMP MAC frame with A and C bits set to 0 is received before the next neighbor notification cycle is started (FSMP=1), it is considered an error.

**Flag, Starting Delimiter (FSD).** The flag FSD is used when counting frames to indicate the presence of a frame. Flag FSD is set to 0 upon entry into the transmit frame data state (in conjunction with the start of transmission of the first frame after token capture) and upon the reception of an ending delimiter. The station may optionally set FSD to 0 when it detects a burst4 error to prevent a premature end to stripping. The flag FSD is set to 1 upon the reception of a starting delimiter. The station may optionally set FSD to 1 when the station transmits its first ED to account for the previous station overstripping the start of the first frame.

**Flag, Test Wait (FTW).** The flag, test wait (FTW) is used by the station when the repeat beacon function detects the need to execute the beacon test function. Using flag, FTW, the station ensures the concentrator has completed its insertion cycle before the station executes Remove\_station. This flag is set to 0 when the station 1) sets its initial conditions and 2) after the station has determined that the remove hold function is complete. This flag is set to 1 when the repeat beacon function detects the need to enter the beacon test function.

**Flag, Transmit Idles (FTI).** The flag FTI is used to control the transmission of idles (fill). When flag FTI is set to 1, the MAC indicates PS\_CONTROL.request(Repeat\_mode=Fill) which causes the station to source fill rather than repeating the received data. When flag FTI is set to 0, the MAC indicates PS\_CONTROL.request(Repeat\_mode=Repeat), which causes the station to repeat the received data.

**Flag, Transmit from Crystal (FTXC).** The flag FTXC is used to select the station's transmitter timing reference. FTXC is also used to indicate when the station's fixed latency buffer is required to assure that the token can exist on the ring. FTXC is set to 1 as a result of entering and set to 0 upon exiting the FSM states requiring crystal transmit (transmit claim token, transmit beacon, or active monitor functions).

When the FTXC flag is set to 1, the MAC indicates PS\_CONTROL.request(Crystal\_transmit=Asserted) which causes the station (as specified in 5.8) to use its crystal clock as the transmit timing reference, provides an elastic buffer, and inserts a fixed latency buffer with a latency at least as large as a token in the data path.

When FTXC is set to 0, the PS\_CONTROL.request(Crystal\_transmit=Not\_asserted) indicates that the station's transmit timing reference is derived from the station's clock recovery circuit and that the elastic and fixed latency buffers are no longer required and are removed from the data path.

**Flag, Transmit Immediate (FTXI).** The flag FTXI is used to indicate whether the station transmits frames with or without waiting for a token. When flag FTXI is set to 1, frame transmit occurs without waiting for a token. When flag FTXI is set to 0, frame transmit occurs after the appropriate token has been captured and indicates that a token needs to be released.

**Flag, Wire Fault (FWF).** Flag FWF is set to 1 to indicate that wire fault is present [see 5.1.4.1 PM\_STATUS.indication (Wire\_fault)]. If no wire fault is detected, FWF is set to 0.

**Flag, Wire Fault Active (FWFA).** Flag FWFA is set to 1 to activate wire fault detection and is set to 0 to deactivate wire fault detection.

#### 4.2.4.3 States

There are a set of states for the Join Ring FSM, the Monitor FSM, and the Transmit FSM. A FSM can be in only one state at any instant in time.

##### 4.2.4.3.1 Join states

The join state (JS=) notation is used to identify the current state of the Join Ring FSM. The join state values are Bypass, Lobe Test, Await New Monitor, Detect Monitor Presence, Duplicate Address Test, Neighbor Notification, Request Initialization, Join Complete, and Bypass Wait. During the Bypass and Bypass Wait states, normal operation is suspended and no assumptions can be made regarding the transmission or reception of data. Join states, listed by state value, are defined as follows:

**Join State J3, Await New Monitor (JS=ANM)** The join state JS=ANM is set when the join ring FSM enters the Await New Monitor state (J3). In this state the station waits for the Claim Token process to establish an active monitor.

**Join State J0, Bypass (JS=BP)** The join state JS=BP is set when the join ring FSM enters the bypass state (J0). In this state the station waits for the connect request and is not required to perform any other function.

**Join State J8, Bypass Wait (JS=BPW)** The join state JS=BPW is set when the join ring FSM enters the bypass wait state (J8). In this state the station must repeat received data and the station remains in this state until the TCU has had ample time to remove the station.

**Join State J2, Detect Monitor Presence (JS=DMP)** The join state JS=DMP is set when the join ring FSM enters the detect monitor presence state (J2). In this state the station waits for an indication that an active monitor exists on the ring.

**Join State J4, Duplicate Address Test (JS=DAT)** The join state JS=DAT is set when the join ring FSM enters the duplicate address test state (J4). In this state the station sends DAT MAC frames to verify that there is not another station on the ring that is using the same MAC address.

**Join State J7, Join Complete (JS=JC)** The join state JS=JC is set when the join ring FSM enters the join complete state (J7). The station has successfully joined the ring and is fully participating in all ring station functions.

**Join State, Lobe Test J1, (JS=LT)** The join state JS=LT is set when the join ring FSM enters the lobe test state (J1). Upon entering the lobe test state, the station shall transmit valid fill for a minimum of 10 ms. The station shall then perform a test to verify the operation of the lobe. The lobe test shall fail if the bit error rate is greater than  $10^{-6}$ . While the station is in JS=LT, it shall transmit only valid frames, tokens, or fill and only test for errors in frames or tokens.

NOTE—The requirement for the station to transmit fill before performing the lobe test allows time for repeaters and the concentrator to synchronize with the transmitted data. A typical extended lobe might contain a copper to fiber repeater at the station and a fiber to copper repeater at the concentrator. Thus the path to the concentrator and back to the station would contain 5 receivers (not counting the station) each one requiring up to 1.5 ms to acquire synchronization. The 6 receivers plus the propagation delay consumes the entire 10 ms budget. Therefore it is recommended that the station transmit fill for a minimum of 20 ms.

**Join State J5, Neighbor Notification (JS=NN)** The join state JS=NN is set when the join ring FSM enters the neighbor notification state (J5). In this state the station waits until it has learned the address of its upstream neighbor.

**Join State J6, Request Initialization (JS=RQI)** The join state JS=RQI is set when the join ring FSM enters the request initialization state (J6). In this state the station transmits Request Initialization MAC frames to the RPS functional address. If the RPS is present, as determined by the settings of the A bits on these frames, the station expects to receive a valid Initialize Station or Change Parameters MAC frame in order to successfully complete the Join Ring process.

#### 4.2.4.3.2 Monitor states

The monitor state (MS=) notation is used to identify the current state of the monitor FSM. The monitor state values are repeat, repeat beacon, repeat claim token, transmit beacon, transmit claim token, transmit ring purge, and beacon test. During the Beacon Test state, no assumptions can be made regarding the transmission or reception of data. Monitor states, listed by state value, are defined as follows:

**Monitor State M4, Beacon Test (MS=BNT)** The monitor state MS=BNT is set when the monitor FSM enters the beacon test state (M4). The station has removed itself from the ring and is performing a self test. During the Beacon Test state, the station assumes it is the only entity on the lobe capable of putting data on the lobe and no assumptions can be made regarding the station's reception of data. Upon entering the lobe test state, the station waits for timer TRW to expire before starting its test sequence. Once the station has started the test sequence, the station shall transmit only valid frames, tokens, or fill and only test for errors in frames or tokens. At the start of the test sequence, the station shall transmit valid fill for a minimum of 10 ms. The station shall then perform a test to verify the operation of the lobe. The lobe test shall fail if the bit error rate is greater than  $10^{-6}$ .

**Monitor State M0, Repeat (MS=RPT)** The monitor state MS=RPT is set when the monitor FSM enters the normal repeat state (M0). The ring is operational.

**Monitor State M5, Repeat Beacon (MS=RBN)** The monitor state MS=RBN is set when the monitor FSM enters the repeat beacon state (M5). The ring is in recovery, another station is transmitting beacon MAC frames.

**Monitor State M6, Repeat Claim Token (MS=RCT)** The monitor state MS=RCT is set when the monitor FSM enters the repeat claim token state (M6). The ring is in recovery, another station is transmitting claim token MAC frames.

**Monitor State M3, Transmit Beacon (MS=TBN)** The monitor state MS=TBN is set when the monitor FSM enters the transmit beacon state (M3). The ring is in recovery, this station is transmitting beacon MAC frames.

**Monitor State M2, Transmit Claim Token (MS=TCT)** The monitor state MS=TCT is set when the monitor FSM enters the transmit claim token state (M2). The ring is in recovery, and this station is transmitting claim token MAC frames (contending to be the active monitor).

**Monitor State M1, Transmit Ring Purge (MS=TRP)** The monitor state MS=TRP is set when the monitor FSM enters the Transmit Ring Purge state (M1). The ring is in recovery and this station is transmitting ring purge MAC frames to clean the ring.

#### 4.2.4.3.3 Transmit states

The transmit state (TS=) notation is used to identify the current state of the transmit FSM. The transmit state values are repeat, transmit frame data, transmit fill, and transmit fill and strip. Transmit states, listed by state value, are defined as follows:

**Transmit State T0, Repeat (TS=RPT)** The transmit state TS=RPT is set when the transmit FSM enters the normal repeat state (T0) and is not transmitting (sourcing) frames.

**Transmit State T1, Transmit Frame Data (TS=DATA)** The transmit state TS=DATA is set when the transmit FSM is transmitting the data portion of the frame (T1).

**Transmit State T2, Transmit Fill (TS=FILL)** The transmit state TS=FILL is set when the transmit FSM has completed transmitting its frame(s), is stripping or waiting to strip its transmitted frame(s) from the ring and prepares to release a token (T2).

**Transmit State T3, Transmit Fill and Strip (TS=STRIP)** The transmit state TS=STRIP is set when the transmit FSM has released a token and is stripping the remainder of its frame(s) from the ring (T3).

### 4.3 Token ring MAC protocol specification

This clause specifies the procedures that are used in the MAC protocol.

The operation of the MAC is specified in this clause. In the case of a discrepancy between the FSM diagrams or table 7 and the supporting text, the FSM diagrams or table 7 take precedence. Table 7 takes precedence over the FSM diagrams.

The MAC receives from the PHY a serial stream of symbols (see 5.1.2.1 PS\_UNITDATA.indication). Each symbol is one of the following:

- a) Data\_zero = zero symbol
- b) Data\_one = one symbol
- c) Non-data\_J = J symbol
- d) Non-data\_K = K symbol

(See 5.3 for a detailed description of these symbols.)

From the received symbols the MAC detects various types of input data, such as tokens, MAC frames, and LLC information frames.

In turn, the MAC stores values, sets flags, and performs certain internal actions as well as generating tokens, frames, fill, or modifying bits and delivering them to the PHY in the form of a serial stream of the Data\_zero, Data\_one, Non-data\_J and Non-data\_K symbols.

For the purpose of accumulating the FCS and storing the contents of a frame, Non-data\_J and Non-data\_K symbols that are not part of the SD or ED shall be interpreted as 1 and 0 values, respectively.

#### 4.3.1 Token identification

Four varieties of token identification are used to describe station operation. They are Token, Good Token, Token Error, and Token with Error. These token varieties are indicated by combinations of the following properties:

### Properties of a token

- A**—Starts with a valid SD.
- B**—Is three octets in length.
- C**—Is composed of only Data\_zero and Data\_one symbols between the SD and ED.
- D**—The T bit (token) is a Data\_zero or optionally a Non-data\_K.
- E**—Third octet is an ED and no ED\_alignment\_error (5.1.2.3).
- F**—No code violations in the P bits.

The four token varieties are defined below. This is not an inclusive list of all possible bit sequence formats; for example, other format sequences known in this standard are the frame and the abort sequence. Note that the value of the I, E, A, and C bits are not part of the following definitions. The notation -E means “not E.”

Good Token (TK\_GOOD) defines the requirements for the entire token, while Token (TK) defines the requirements for a token that is captured to start transmission. In the latter case, only the first half of the token has been received which the transmit FSM changes into a start-of-frame sequence.

**Good Token (TK\_GOOD).** A bit sequence that satisfies the following conditions based on the properties of a token listed above:

**A & B & C & D & E**

**Token (TK).** A bit sequence that satisfies the following condition, based on the properties of a token listed above:

**A & D & F**

**Token Access Control (TK\_AC).** A bit sequence that satisfies the following condition, based on the properties of a token listed above:

**A & D & optionally F**

**Token Error (TK\_ERR).** A bit sequence that satisfies the following condition, based on the properties of a token listed above:

**A & D & -E**

**Token with Error (TK\_WITH\_ERR).** A bit sequence that satisfies the following condition, based on the properties of a token listed above:

**A & B & -C & D & E**

#### 4.3.2 Frame identification

Two definitions of frame validity are used to describe station operation. They are frame (FR) and frame with error (FR\_WITH\_ERR). The definition FR\_AC is provided to define the valid start of a frame.

These frame validity definitions are indicated by combinations of the following properties:

**Properties of a frame**

- A**—Starts with a valid SD.
- B**—Has the E (error) bit equal to 0.
- C**—Is an integral number of octets in length and no ED\_alignment\_error (5.1.2.3).
- D**—Is composed of only Data\_zero and Data\_one symbols between the SD and ED.
- E**—Has the FF bits of the Frame Control field equal to 00 or 01.
- F**—Has a valid FCS.
- G**—Has a minimum of 18 octets between SD and ED.
- H**—Does not contain a valid SD or ED between the bounding SD and ED.
- J**—The end is delimited by a valid ED.
- K**—Has no code violations in P and T, and optionally M, and optionally R.
- L**—T bit is equal to a 1 indicating a frame.

The frame validity requirements are defined below. This is not an inclusive list of all possible bit sequence formats; for example, other format sequences known in this standard are the token and the abort sequence. Note that the value of the I, E, A, and C bits are not part of the following definitions.

**Frame (FR).** A valid frame is a bit sequence that satisfies the following condition, based on the properties of a frame listed previously:

**E & A & C & D & J & L & G & F** (for MAC and LLC frames)  
or **-E & A & C & D & J & L** (for undefined frame formats)

**Frame with Error (FR\_WITH\_ERR).** A bit sequence that satisfies the following condition:

**E & A & H & J & L & (-C or -D or -F or -G)** (for MAC and LLC frames)  
or **-E & A & H & J & L & (-C or -D)** (for undefined frame formats)

In addition to frame validity, the identification of the start of a frame is defined as:

**Frame Access Control (FR\_AC).** A bit sequence that identifies the following condition:

**A & K & L**

Even though property K allows for variation, the station shall use a single definition for FR\_AC for all instances of use.

**4.3.3 Actions on frame errors**

**Frames received in error:** Unless otherwise specified, a frame that is received with an error (FR\_WITH\_ERR) is not processed.

**Transmission errors:** When a station is transmitting, it shall inspect the received data to determine if its transmitted frame(s) was successfully propagated around the ring. Any frame error (as stated above) or the inability to recognize that the transmitted frame returned to the station is considered a transmission error. Frames that must be re-transmitted as a result of a transmission error are specified in table 7; otherwise, the MAC does not re-transmit the frame.

The capability to recognize that a transmitted frame has been lost (failed to return to the station) is provided by the TRR timer. When a station finishes transmitting its frame(s) it starts TRR and will normally wait in transmit state TS=FILL or TS=STRIP until it receives the SA of the last frame it transmitted. If TRR expires while the station is in TS=FILL or TS=STRIP, then the frame(s) is lost. The frame is

also considered lost if, when the last frame returns, as determined by the frame counter (CFR), the SA does not match the stored SA of the last transmitted frame (LTA).

During the Ring Purge process, the TRR timer is also used to detect lost Ring Purge frames. If the frame returns to the station, then the station releases a token and transitions out of the MS=TRP state. If TRR expires while the station is in MS=TRP, then the Ring Purge frame was lost.

#### 4.3.4 Station operation tables

Table 7 is used to precisely specify the operation of the token ring station. Each entry in the table contains:

- a) A state transition (S/T) indication that correlates to a transition on the appropriate FSM diagram in annex F.
- b) A reference designator (REF) is assigned to the event. The sole purpose of the reference designator is to precisely identify the transition when necessary. The value of the reference designator is otherwise completely arbitrary and should not be interpreted to convey any other meaning.
- c) Event/condition is a list of terms that can be equated to being true or false. If the event/condition equates true, then the specified action/output shall be performed. If the event/condition equates false, then the action/output shall be ignored. The highlighted term is the event that occurred or term that changed to cause the event/condition to be true.
- d) Action/output is a list of terms that are equated to actions (internal to the MAC) or outputs (external to the MAC) that shall be performed as specified in 4.2.1 when the event/condition is true. If the event/condition equates false, then the action/output shall be ignored.

It is possible that a single occurrence of an event causes multiple event/condition terms to equate true. In this case, the actions/outputs of all table entries that equate true shall be performed.

The precise terms used for the events are specified in 4.3.5.1 using the definitions from previous clauses. The precise terms used for the actions/outputs are specified in 4.3.5.2 using the definitions from previous clauses.

Where possible, the first term of the event/condition is the dynamic event that occurred and the following terms are the static conditions. Table 7's order is based on the alphanumeric value of the event. The position of the entry in the table has no significant meaning.

The starting state for the join state machine shall be JS=BP.

For the purpose of allowing flexibility among stations, parameters n1 through n5 are used in the Station Operation tables to represent certain counter thresholds. The minimum and maximum allowable threshold values are specified in table 6. The maximum values are the recommended values.

**Table 6—Definition of Parameters n1 through n5**

Parameters	Min	Max	Used with	Description
n1	1	3	CCR CCT	n1 is the number of the station's own Claim Token MAC frames that must have been received before the station can become active monitor.
n2	1	2	CDG CDF	n2 is the number of DAT frames that must be received without address conflict before the station assumes its address is unique or the number of DAT frames received with conflict before the station assumes that it is a duplicate.
n3	1	4	CER CSC	n3 is the number of attempts to send an Error Report frame or a Report SUA Change frame when the destination server exists but fails to copy the frame.
n4	1	4	CRI CRIN	n4 is the number of Request Initialization frames sent to the RPS to determine that the RPS function is not present or if it is present, n4 is the number of Request Initialization frames sent waiting for the RPS to initialize the station.
n5	1	2	CNNR	n5 is the number of Neighbor Notification cycles that must be started after the ring is purged before the station reports AC errors.

**Table 7—MAC Station Operation table**

The following notation is used throughout table 7:

(optional-i)—Implementations are encouraged to include this action.

(optional-x)—Implementations are encouraged to exclude this action.

(optional)—Implementations may include this action.

**Table 7—MAC Station Operation table**

S/T	REF	Event/condition	Action/output
	001	Burst5_error_event & MS=RPT & FINS=1 & FER=0	TER=R; FER=1; CBE=(CBE+1)
	002	Burst5_error_event & MS=RPT & FINS=1 & FER=1 & CBE<255	CBE=(CBE+1)
M54	003	CBR=0 & MS=RBN & FBR=0	MS=BNT; FBR=FTW=1
	004	CER=n3 & FECO=0	FER=FLF=0; CER=0; SET ERR_CNTR to 0;
	005	CER=n3 & FECO=1	FLF=0; CER=0; SET ERR_CNTR to 0;
J01	006	Connect.MAC & JS=BP	JS=LT; Set_initial_conditions; FTI=x; TEST
J38	007	Disconnect.MAC & JS=ANM	JS=BPW
J48	008	Disconnect.MAC & JS=DAT	JS=BPW
J28	009	Disconnect.MAC & JS=DMP	JS=BPW
J78	010	Disconnect.MAC & JS=JC	JS=BPW; FINS=FJR=FDC=FNC=0
J58	011	Disconnect.MAC & JS=NN	JS=BPW; FDC=0
J68	012	Disconnect.MAC & JS=RQI	JS=BPW; FINS=FDC=FNC=0
	013	EOD & TS=DATA & FED=0 & FTXI=0	FED=1; [FSD=1 (optional-i)]
T12	014	EOD & TS=DATA & FTXI=0 & QUE_EMPTY	TS=FILL; FTI=1; TRR=R; TX_FCS; TX_EFS(I=0)
T12	015	EOD & TS=DATA & FTXI=0 & QUE_NOT_EMPTY & (CTO-FR_LTH<0)	TS=FILL; FTI=1; TRR=R; TX_FCS; TX_EFS(I=0)
T12	016	EOD & TS=DATA & FTXI=0 & QUE_NOT_EMPTY & (CTO-FR_LTH>=0) & Pm<Pr	TS=FILL; FTI=1; TRR=R; TX_FCS; TX_EFS(I=0)
T12	017	EOD & TS=DATA & FTXI=0 & QUE_NOT_EMPTY & (CTO-FR_LTH>=0) & Pm>=Pr & FMFTO=0 & Pm<Rr	TS=FILL; FTI=1; TRR=R; TX_FCS; TX_EFS(I=0)
T11	018	EOD & TS=DATA & FTXI=0 & QUE_NOT_EMPTY & (CTO-FR_LTH>=0) & Pm>=Pr & FMFTO=0 & Pm>=Rr	TS=DATA; CFR=(CFR+1); CTO=(CTO-FR_LTH); TX_FCS; TX_EFS(I=x); TX_SFS(P=Pr;R=0); LTA=TX_SA
T11	019	EOD & TS=DATA & FTXI=0 & QUE_NOT_EMPTY & (CTO-FR_LTH>=0) & Pm>=Pr & FMFTO=1	TS=DATA; CFR=(CFR+1); CTO=(CTO-FR_LTH); TX_FCS; TX_EFS(I=x); TX_SFS(P=Pr;R=0); LTA=TX_SA
T10A	020	EOD & TS=DATA & FTXI=1 & MS=RBN	TS=RPT; FTXI=FTXC=0; TX_FCS; TX_EFS(I=0)
T10A	021	EOD & TS=DATA & FTXI=1 & MS=RCT	TS=RPT; FTXI=FTXC=0; TX_FCS; TX_EFS(I=0)
T10A	022	EOD & TS=DATA & FTXI=1 & MS=RPT	TS=RPT; FTXI=FTXC=0; TX_FCS; TX_EFS(I=0)
T10B	023	EOD & TS=DATA & FTXI=1 & MS=TBN	TS=RPT; FTXI=0; FTI=1; TX_FCS; TX_EFS(I=0)
T10B	024	EOD & TS=DATA & FTXI=1 & MS=TCT	TS=RPT; FTXI=0; FTI=1; TX_FCS; TX_EFS(I=0)
T10C	025	EOD & TS=DATA & FTXI=1 & MS=TRP	TS=RPT; FTXI=0; FTI=1; TX_FCS; TX_EFS(I=0); TRR=R
M02	026	FANM=1 & MS=RPT & JS=ANM	MS=TCT; FANM=FCT=0; FTXC=FTI=1; TCT=R; TQP=R; CCT=1; CCR=1; TXI(CT_PDU)
	027	FDC=1 & FNW=1 & FNC=0 & MS=RPT & FAM=0	FNC=1; QUE_SMP_PDU
	028	FDC=1 & FNW=1 & FNC=0 & MS=RPT & FAM=1	FNC=1
	029	FJR=1 & FBHO=1 & FINS=0	FLF=0; FINS=1
	030	FJR=1 & FBHO=1 & FINS=0 & FECO=1	TER=R; FER=1
	031	FLF=1 & MS=RPT & FINS=1 & FER=0	FLF=0; FER=1; TER=R; CLFE=(CLFE+1)
	032	FLF=1 & MS=RPT & FINS=1 & FER=1 & CLFE<255	FLF=0; CLFE=(CLFE+1)
	033	FNC=1 & FBHO=0 & FINS=0	FLF=0; FINS=1

**Table 7—MAC Station Operation table (Continued)**

S/T	REF	Event/condition	Action/output
	034	FNC=1 & FBHO=0 & FINS=0 & FECO=1	FER=1; TER=R
J56	035	FNC=1 & JS=NN	JS=RQI; TJR=R; TRI=R; CRI=1; CRIN=1; QUE_RQ_INIT_PDU
T30D	036	FNMA=1 & CFR=1 & TS=STRIP	TS=RPT; FTI=0; FLF=1
	037	FR & FJR=1 & MS<>BNT	M_UNITDATA.indication
M52	038	FR(DA=Any_recognized_address) & FID=1 & MS=RBN	MS=TCT; FCT=FID=0; FTXC=FTI=1; TCT=R; TQP=R; CCT=1; CCR=1; TXI(CT_PDU)
	039	FR(DA=Any_recognized_address) & FID=1 & MS=TCN	FID=0; FTI=1; TQP=R; TXI(BN_PDU)
	040	FR(DA=Any_recognized_address) & FTI=0 & TS=RPT	SET A=1
	041	FR(DA=MA & A=1) & MS=RPT & FINS=1 & FER=0	FER=1; TER=R; CFCE=(CFCE+1)
	042	FR(DA=MA & A=1) & MS=RPT & FINS=1 & FER=1 & CFCE<255	CFCE=(CFCE+1)
	043	FR(P<Sx)	[CLEAR_STACKS (optional-i)]
	044	RCV(SA<>LTA) & CFR=1	FNMA=1
	045	RCV(SA=LTA) & CFR=1	FMA=1
	046	FR_AC & FAM=0 & FPT=1 & FGTO=0	TNT=R; FPT=0
	047	FR_AC(M=0) & FAM=1 & FTI=0 & TS=RPT	SET M=1
	048	FR_AC(M=0) & FAM=1 & FTHO=0	TVX=R
	049	FR_AC(M=0) & FAM=1 & FTHO=1	FAT=1
	050	FR_AC(M=0) & MS=RBN & CBC=0 & FTI=0 & TS=RPT	[SET M=1 (optional-i)]
M01	051	FR_AC(M=1) & FAM=1 & MS=RPT	MS=TRP; FTI=1; TRP=R; TXI(RP_PDU)
	052	FR_AC(M=1) & FAM=1 & MS=RPT & FINS=1 & FER=0	FER=1; TER=R; CTE=(CTE+1)
	053	FR_AC(M=1) & FAM=1 & MS=RPT & FINS=1 & FER=1 & CTE<255	CTE=(CTE+1)
	054	FR_AC(R<Pm) & PDU_QUEUED & FTI=0 & TS=RPT & FOP=1	SET R=Pm
	055	FR_AMP & CNNR<>0	CNNR=(CNNR-1)
	056	FR_AMP & FAM=1	[TSM=R (optional-i)]
	057	FR_AMP & FAM=0 & FINS=1	TSM=R
J24	058	FR_AMP & JS=DMP	JS=DAT; FMP=1; TJR=R; CDF=0; CDG=0; QUE_DAT_PDU
	059	FR_AMP(A=0 & C=0) & FAM=0 & FOP=1	FSMP=1; TQP=R
	060	FR_AMP(AIC<>0) & FAM=0	FSMP=0
	061	FR_AMP(SA<>MA) & FAM=1	QUE_ACT_ERR_PDU(EC=2); FAM=0; FA(monitor)=0
	062	FR_AMP(SA<>MA) & FAM=1 & FINS=1	TNT=R
	063	FR_AMP(SA<>MA) & FAM=1 & TS=RPT	FTXC=FTI=0
	064	FR_AMP(SA<>SUA & A=0 & C=0) & FOP=1	CSC=1; SUA=SA ; QUE_SUA_CHG_PDU
	065	FR_AMP(SA=MA & A=0 & C=0) & FAM=1	FNN=FNW=1; LMP=NULL
	066	FR_AMP(SA=MA & AIC<>0) & FAM=1	LMP=SA

**Table 7—MAC Station Operation table (Continued)**

S/T	REF	Event/condition	Action/output
J38	067	FR_BN & JS=ANM	JS=BPW
J48	068	FR_BN & JS=DAT	JS=BPW
J28	069	FR_BN & JS=DMP	JS=BPW
J58	070	FR_BN & JS=NN	JS=BPW; FDC=0
J68	071	FR_BN & JS=RQI & MS<>TBN & FINS=0	JS=BPW; FDC=FNC=0
	072	FR_BN & MS<>TBN & MS<>BNT & FINS=1	TBR=R
M65	073	FR_BN & MS=RCT & FINS=1	MS=RBN
	074	FR_BN & MS=RPT & FAM=1 & TS=RPT	FTXC=0
M05	075	FR_BN & MS=RPT & FINS=1	MS=RBN; FAM=0; FA(monitor)=0
M25	076	FR_BN & MS=TCT & FINS=1	MS=RBN
	077	FR_BN & MS=TCT & FINS=1 & TS=RPT	FTXC=FTI=0
M15	078	FR_BN & MS=TRP & FINS=1	MS=RBN; FAM=0; FA(monitor)=0
	079	FR_BN & MS=TRP & FINS=1 & TS=RPT	FTXC=FTI=0
M32	080	FR_BN(M=0 & SA=MA) & MS=TBN & FID=0	MS=TCT; FCT=0; TCT=R; TQP=R; CCT=1; CCR=1; TXI(CT_PDU)
J68	081	FR_BN(SA<>MA & BN_TYPE<=TX_BN_TYPE) & MS=TBN & FINS=0 & JS=RQI	JS=BPW; FDC=FNC=0
M35	082	FR_BN(SA<>MA & BN_TYPE<=TX_BN_TYPE) & MS=TBN & FID=0 & FINS=1	MS=RBN; TBR=R
	083	FR_BN(SA<>MA & BN_TYPE<=TX_BN_TYPE) & MS=TBN & FID=0 & FINS=1 & TS=RPT	FTXC=FTI=0
	084	FR_BN(SA<>SUA)	CBC=2
	085	FR_BN(SA=SUA & UNA=MA) & FBR=0	CBC=2
	086	FR_BN(SA=SUA & UNA<>MA) & MS<>RBN & FBR=0 & MS<>BNT	CBC=1
	087	FR_BN(SA=SUA & UNA<>MA) & CBC=0 & MS=RBN	CBC=1
	088	FR_BN(SA=SUA) & FBR=1 & MS<>RBN & MS<>BNT	CBC=1
	089	FR_BN(SA=SUA) & FBR=1 & CBC=0 & MS=RBN	CBC=1
	090	FR_BN(SA=SUA & UNA<>MA) & FBR=0 & CBC>0 & MS=RBN	CBC=(CBC-1)
	091	FR_BN(SA=SUA) & FBR=1 & CBC>0 & MS=RBN	CBC=(CBC-1)
	092	FR_BN(UNA<>MA)	CBR=8
	093	FR_BN(UNA=MA & BN_TYPE=1)	CBR=8
	094	FR_BN(SA<>MA & UNA=MA & BN_TYPE<>1) & FBR=0 & MS<>RBN & MS<>BNT	CBR=7
	095	FR_BN(UNA=MA & BN_TYPE<>1) & FBR=0 & MS=RBN	CBR=(CBR-1)

**Table 7—MAC Station Operation table (Continued)**

S/T	REF	Event/condition	Action/output
M52	096	FR_BN_CIR & MS=RBN & CBC<>2 & FINS=1	[MS=TCT; FCT=0; FTXC=FTI=1; TCT=R; TQP=R; CCT=1; CCR=1; TXI(CT_PDU) (optional-i)]
	097	FR_CHG_PARM & FOP=1	SET APPR_PARMS
	098	FR_CHG_PARM(DA=broadcast & AIC<>1 & CORR_NOT_PRESENT) & FOP=1	QUE_RSP_PDU(DC=RCV_SC; SC=RS; CORR=UNK_VALUE; RSP_TYPE=0001)
	099	FR_CHG_PARM(DA=broadcast & AIC<>1 & CORR_PRESENT) & FOP=1	QUE_RSP_PDU(DC=RCV_SC; SC=RS; CORR=RCV_CORR; RSP_TYPE=0001)
J67	100	FR_CHG_PARM(DA=MA) & JS=RQI	JS=JC; FJR=1; TWFD=R; FWFA=FWF=0
	101	FR_CHG_PARM(DA=Non_broadcast & CORR_NOT_PRESENT) & FOP=1	QUE_RSP_PDU(DC=RCV_SC; SC=RS; CORR=UNK_VALUE; RSP_TYPE=0001)
	102	FR_CHG_PARM(DA=Non_broadcast & CORR_PRESENT) & FOP=1	QUE_RSP_PDU(DC=RCV_SC; SC=RS; CORR=RCV_CORR; RSP_TYPE=0001)
	103	FR_COPIED(DA=Any_recognized_address) & FTI=0 & TS=RPT	SET C=1
	104	FR_CT & FAM=1	FAM=0; QUE_ACT_ERR_PDU(EC=1); FA(monitor)=0
	105	FR_CT & FAM=1 & TS=RPT	FTXC=FTI=0
J23B	106	FR_CT & JS=DMP	JS=ANM
	107	FR_CT & MS<>TBN & FCT=0	FCT=1
M16	108	FR_CT & MS=TRP	MS=RCT; TCT=R
M26A	109	FR_CT(M=0 & SA=MA & UNA<>SUA) & MS=TCT	MS=RCT; TCT=R; QUE_ACT_ERR_PDU(EC=3)
	110	FR_CT(M=0 & SA=MA & UNA<>SUA) & MS=TCT & TS=RPT	FTXC=FTI=0
M21	111	FR_CT(M=0 & SA=MA & UNA=SUA) & CCT>=n1 & CCR>=n1 & MS=TCT	MS=TRP; FAM=1; TRP=R; TXI(RP_PDU); QUE_NEW_MON_PDU; FA(monitor)=1
	112	FR_CT(M=0 & SA=MA & UNA=SUA) & MS=TCT	CCR=(CCR+1)
M56	113	FR_CT(SA<MA) & MS=RBN & FCCO=0 & FID=0	MS=RCT; TCT=R
M52	114	FR_CT(SA<MA) & MS=RBN & FCCO=1 & FINS=1	MS=TCT; FCT=0; FTXC=FTI=1; TCT=R; TQP=R; CCT=1; CCR=1; TXI(CT_PDU)
M06	115	FR_CT(SA<MA) & MS=RPT & FAM=1	MS=RCT; TCT=R
M06	116	FR_CT(SA<MA) & MS=RPT & FCCO=0 & FOP=1	MS=RCT; TCT=R
M02	117	FR_CT(SA<MA) & MS=RPT & FCCO=1 & FAM=0 & FINS=1	MS=TCT; FCT=0; FTXC=FTI=1; TCT=R; TQP=R; CCT=1; CCR=1; TXI(CT_PDU)
M06	118	FR_CT(SA<MA) & MS=RPT & FINS=0 & FOP=1	MS=RCT; TCT=R
M56	119	FR_CT(SA>MA) & MS=RBN & FID=0	MS=RCT; TCT=R
M06	120	FR_CT(SA>MA) & MS=RPT & FOP=1	MS=RCT; TCT=R
M26B	121	FR_CT(SA>MA) & MS=TCT	MS=RCT; TCT=R
	122	FR_CT(SA>MA) & MS=TCT	[TXI(RCV_CT_PDU) (optional-i)]
	123	FR_CT(SA>MA) & MS=TCT & TS=RPT	FTXC=FTI=0
	124	FR_DAT(SA=MA & A=0 & C=0) & CDG<(n2-1) & JS=DAT	CDG=(CDG+1); QUE_DAT_PDU
J45	125	FR_DAT(SA=MA & A=0 & C=0) & CDG=(n2-1) & JS=DAT	JS=NN; FDC=1; TJR=R
	126	FR_DAT(SA=MA & AIC<>0) & CDF<(n2-1) & JS=DAT	CDF=(CDF+1); QUE_DAT_PDU
J48	127	FR_DAT(SA=MA & AIC<>0) & CDF=(n2-1) & JS=DAT	JS=BPW

**Table 7—MAC Station Operation table (Continued)**

S/T	REF	Event/condition	Action/output
	128	FR_INIT & FOP=1	SET APPR_PARMS
	129	FR_INIT(DA=broadcast & AIC<>1 & CORR_NOT_PRESENT) & FOP=1	QUE_RSP_PDU(DC=RPS; SC=RS;CORR=UNK_VALUE; RSP_TYPE=0001)
	130	FR_INIT(DA=broadcast & AIC<>1 & CORR_PRESENT) & FOP=1	QUE_RSP_PDU(DC=RPS; SC=RS;CORR=RCV_CORR; RSP_TYPE=0001)
J67	131	FR_INIT(DA=MA) & JS=RQI	JS=JC; FWFA=FWF=0; FJR=1; TWFD=R
	132	FR_INIT(DA=Non_broadcast & CORR_NOT_PRESENT) & FOP=1	QUE_RSP_PDU(DC=RPS; SC=RS;CORR=UNK_VALUE; RSP_TYPE=0001)
	133	FR_INIT(DA=Non_broadcast & CORR_PRESENT) & FOP=1	QUE_RSP_PDU(DC=RPS; SC=RS;CORR=RCV_CORR; RSP_TYPE=0001)
	134	FR_LLC(DA=Any_recognized_address) & FJR=1 & MS<>BNT	MA_UNITDATA.indication
	135	FR_MAC(DA=Any_recognized_address & DC<>0) & FJR=1 & MS<>BNT	MGT_UNITDATA.indication
	136	FR_MAC_INV(ERR_COND=LONG_MAC & SC<>RS & CORR_NOT_PRESENT) & FOP=1	QUE_RSP_PDU(DC=RCV_SC; SC=RS; CORR=UNK_VALUE; RSP_TYPE=8009)
	137	FR_MAC_INV(ERR_COND=LONG_MAC & SC<>RS & CORR_PRESENT) & FOP=1	QUE_RSP_PDU(DC=RCV_SC; SC=RS; CORR=RCV_CORR; RSP_TYPE=8009)
	138	FR_MAC_INV(ERR_COND=SC_INVALID & SC<>RS & CORR_NOT_PRESENT) & FOP=1	QUE_RSP_PDU(DC=RCV_SC; SC=RS; CORR=UNK_VALUE; RSP_TYPE=8004)
	139	FR_MAC_INV(ERR_COND=SC_INVALID & SC<>RS & CORR_PRESENT) & FOP=1	QUE_RSP_PDU(DC=RCV_SC; SC=RS; CORR=RCV_CORR; RSP_TYPE=8004)
	140	FR_MAC_INV(ERR_COND=SHORT_MAC & SC_NOT_PRESENT) & FOP=1	QUE_RSP_PDU(DC<>RS; SC=RS; CORR=UNK_VALUE; RSP_TYPE=8001)
	141	FR_MAC_INV(ERR_COND=SHORT_MAC & SC_PRESENT & SC<>RS) & FOP=1	QUE_RSP_PDU(DC=RCV_SC; SC=RS; CORR=RCV_CORR; RSP_TYPE=8001)
	142	FR_MAC_INV(ERR_COND=SV_LTH_ERR & SC<>RS & CORR_NOT_PRESENT) & FOP=1	QUE_RSP_PDU(DC=RCV_SC; SC=RS; CORR=UNK_VALUE; RSP_TYPE=8005)
	143	FR_MAC_INV(ERR_COND=SV_LTH_ERR & SC<>RS & CORR_PRESENT) & FOP=1	QUE_RSP_PDU(DC=RCV_SC; SC=RS; CORR=RCV_CORR; RSP_TYPE=8005)
	144	FR_MAC_INV(ERR_COND=SV_MISSING & SC<>RS & CORR_NOT_PRESENT) & FOP=1	QUE_RSP_PDU(DC=RCV_SC; SC=RS; CORR=UNK_VALUE; RSP_TYPE=8007)
	145	FR_MAC_INV(ERR_COND=SV_MISSING & SC<>RS & CORR_PRESENT) & FOP=1	QUE_RSP_PDU(DC=RCV_SC; SC=RS; CORR=RCV_CORR; RSP_TYPE=8007)
	146	FR_MAC_INV(ERR_COND=SV_UNK & SC<>RS & CORR_NOT_PRESENT) & FOP=1	QUE_RSP_PDU(DC=RCV_SC; SC=RS; CORR=UNK_VALUE; RSP_TYPE=8008)
	147	FR_MAC_INV(ERR_COND=SV_UNK & SC<>RS & CORR_PRESENT) & FOP=1	QUE_RSP_PDU(DC=RCV_SC; SC=RS; CORR=RCV_CORR; RSP_TYPE=8008)
	148	FR_MAC_INV(ERR_COND=VI_LTH_ERR & SC<>RS & CORR_NOT_PRESENT) & FOP=1	QUE_RSP_PDU(DC=RCV_SC; SC=RS; CORR=UNK_VALUE; RSP_TYPE=8002)
	149	FR_MAC_INV(ERR_COND=VI_LTH_ERR & SC<>RS & CORR_PRESENT) & FOP=1	QUE_RSP_PDU(DC=RCV_SC; SC=RS; CORR=RCV_CORR; RSP_TYPE=8002)
	150	FR_MAC_INV(ERR_COND=VI_UNK & SC<>RS & CORR_NOT_PRESENT) & FOP=1	QUE_RSP_PDU(DC=RCV_SC; SC=RS; CORR=UNK_VALUE; RSP_TYPE=8003)
	151	FR_MAC_INV(ERR_COND=VI_UNK & SC<>RS & CORR_PRESENT) & FOP=1	QUE_RSP_PDU(DC=RCV_SC; SC=RS; CORR=RCV_CORR; RSP_TYPE=8003)
	152	FR_NOT_COPIED & MS=RPT & FINS=1 & FER=0	FER=1; TER=R; CRCE=(CRCE+1)
	153	FR_NOT_COPIED & MS=RPT & FINS=1 & FER=1 & CRCE<255	CRCE=(CRCE+1)

**Table 7—MAC Station Operation table (Continued)**

S/T	REF	Event/condition	Action/output
	154	FR_REMOVE(DA=Broadcast & A<>1) & FOP=1	[QUE_RSP_PDU(DC=RCV_SC; SC=RS; RSP_TYPE=800A) (optional-i)]
	155	FR_REMOVE(DA=Broadcast & A=1) & FOP=1	[QUE_RSP_PDU(DC=RCV_SC; SC=RS; RSP_TYPE=800A) (optional-x)]
J38	156	FR_REMOVE(DA=Non_broadcast) & FRRO=0 & JS=ANM	JS=BPW
J48	157	FR_REMOVE(DA=Non_broadcast) & FRRO=0 & JS=DAT	JS=BPW
J28	158	FR_REMOVE(DA=Non_broadcast) & FRRO=0 & JS=DMP	JS=BPW
J78	159	FR_REMOVE(DA=Non_broadcast) & FRRO=0 & JS=JC	JS=BPW; FINS=FJR=FDC=FNC=0
J58	160	FR_REMOVE(DA=Non_broadcast) & FRRO=0 & JS=NN	JS=BPW; FDC=0
J68	161	FR_REMOVE(DA=Non_broadcast) & FRRO=0 & JS=RQI	JS=BPW; FINS=FDC=FNC=0
	162	FR_REMOVE(DA=Non_broadcast) & FRRO=1 & FOP=1	QUE_RSP_PDU(DC=RCV_SC; SC=RS; RSP_TYPE=800A)
	163	FR_RP	CNNR=n5
J34	164	FR_RP & JS=ANM	JS=DAT; FMP=1; TJR=R; CDF=0; CDG=0; QUE_DAT_PDU
J24	165	FR_RP & JS=DMP	JS=DAT; FMP=1; TJR=R; CDF=0; CDG=0; QUE_DAT_PDU
	166	FR_RP & MS=RCT & FINS=1	FBR=FBT=0
	167	FR_RP & MS=RPT & FINS=1	FBR=FBT=0
	168	FR_RP & MS=TRP & FINS=1	FBR=FBT=0
M60	169	FR_RP & MS=RCT	MS=RPT
	170	FR_RP & MS=RCT & FINS=1	TNT=R; TSM=R
	171	FR_RP & MS=RPT & FAM=1	FAM=0; QUE_ACT_ERR_PDU(EC=2); FA(monitor)=0
	172	FR_RP & MS=RPT & FAM=1 & TS=RPT	FTXC=FTI=0
	173	FR_RP & MS=RPT & FAM=1 & FINS=1	TNT=R; [TSM=R (optional-i)]
	174	FR_RP(SA<>MA) & FAM=0 & FINS=1	[TNT=R (optional-x)]
M10B	175	FR_RP(SA<>MA) & MS=TRP	MS=RPT; FAM=0; QUE_ACT_ERR_PDU(EC=2); FA(monitor)=0
	176	FR_RP(SA<>MA) & MS=TRP & TS=RPT	FTXC=FTI=0
M10A	177	FR_RP(SA=MA & R=0) & MS=TRP	MS=RPT; FAT=FTI=FNN=0; FMP=1; TVX=R; TAM=R; TX_TK(P=0; M=0;R=0); CLEAR_STACKS; QUE_AMP_PDU; LMP=(MAINULL); [TSM=R (optional-i)]
M10A	178	FR_RP(SA=MA & R>0) & MS=TRP	MS=RPT; FAT=FTI=FNN=0; FMP=1; TVX=R; TAM=R; TX_TK(P=Rr; M=0;R=0); RE-SET_STACKS(Sx=Rr;Sr=0); QUE_AMP_PDU; LMP=(MAINULL); [TSM=R (optional-i)]

**Table 7—MAC Station Operation table (Continued)**

S/T	REF	Event/condition	Action/output
	179	FR_RPRT_ERR(SA=MA & A=1 & C<>0) & CER<n3 & FECO=0 & FOP=1	FER=FLF=0; CER=0; SET ERR_CNTR to 0
	180	FR_RPRT_ERR(SA=MA & A=1 & C<>0) & CER<n3 & FECO=1 & FOP=1	FLF=0; CER=0; SET ERR_CNTR to 0
	181	FR_RPRT_ERR(SA=MA & E=0 & A=0) & CER<n3 & FECO=0 & FOP=1	FER=FLF=0; CER=0; SET ERR_CNTR to 0
	182	FR_RPRT_ERR(SA=MA & E=0 & A=0) & CER<n3 & FECO=1 & FOP=1	FLF=0; CER=0; SET ERR_CNTR to 0
	183	FR_RPRT_ERR(SA=MA & E=0 & A=1 & C=0) & CER<n3 & FOP=1	CER=(CER+1); QUE_RPRT_ERR_PDU
	184	FR_RPRT_ERR(SA=MA & E=1 & C=0) & CER<n3 & FOP=1	CER=(CER+1); QUE_RPRT_ERR_PDU
	185	FR_RQ_ADDR & FOP=1	QUE_RPRT_ADDR_PDU
	186	FR_RQ_ATTACH & FOP=1	QUE_RPRT_ATTACH_PDU
	187	FR_RQ_INIT(SA=MA & A<>1) & CRIN<n4 & JS=RQI	TRI=R; CRIN=(CRIN+1); QUE_RQ_INIT
J67	188	FR_RQ_INIT(SA=MA & A<>1) & CRIN=n4 & JS=RQI	JS=JC; FWFA=FWF=0; FJR=1; TWFD=R
	189	FR_RQ_INIT(SA=MA & A=1) & CRI<n4 & JS=RQI	TRI=R
	190	FR_RQ_STATE & FOP=1	QUE_RPRT_STATE_PDU
J24	191	FR_SMP & JS=DMP	JS=DAT; FMP=1; TJR=R; CDF=0; CDG=0; QUE_DAT_PDU
	192	FR_SMP(A=0 & C=0) & FAM=1	FNN=FNW=1; LMP=NULL
	193	FR_SMP(A=0 & C=0) & FSMP=0 & FAM=0 & FOP=1	FSMP=1; TQP=R
	194	FR_SMP(A=0 & C=0) & FSMP=1 & MS=RPT & FINS=1 & FAM=0 & CNNR=0 & FER=0	FER=1; TER=R; CACE=(CACE+1)
	195	FR_SMP(A=0 & C=0) & FSMP=1 & MS=RPT & FINS=1 & FAM=0 & CNNR=0 & FER=1 & CACE<255	CACE=(CACE+1)
	196	FR_SMP(A=0 & C=0) & MS=RPT & FINS=1 & FAM=1 & FNN=1 & CNNR=0 & FER=0	TER=R; FER=1; CACE=(CACE+1)
	197	FR_SMP(A=0 & C=0) & MS=RPT & FINS=1 & FAM=1 & FNN=1 & CNNR=0 & FER=1 & CACE<255	CACE=(CACE+1)
	198	FR_SMP(AIC<>0) & FAM=1	LMP=SA
	199	FR_SMP(SA<>SUA & A=0 & C=0) & FAM=0 & FOP=1	CSC=1; SUA=SA; QUE_SUA_CHG_PDU
	200	FR_SMP(SA<>SUA & A=0 & C=0) & FAM=1 & FNN=0 & FOP=1	CSC=1; SUA=SA; QUE_SUA_CHG_PDU
	201	FR_SUA_CHG(SA=MA & E=0 & A=1 & C=0) & CSC<n3 & FOP=1	CSC=(CSC+1); QUE_SUA_CHG_PDU
	202	FR_SUA_CHG(SA=MA & E=1 & C=0) & CSC<n3 & FOP=1	CSC=(CSC+1); QUE_SUA_CHG_PDU
	203	FR_WITH_ERR & FTI=0 & TS=RPT	SET E=1
	204	FR_WITH_ERR(E=0) & MS=RPT & FINS=1 & FER=0	FER=1; TER=R; CLE=(CLE+1)
	205	FR_WITH_ERR(E=0) & MS=RPT & FINS=1 & FER=1 & CLE<255	CLE=(CLE+1)

**Table 7—MAC Station Operation table (Continued)**

S/T	REF	Event/condition	Action/output
	206	FRH=0 & JS=BPW	MS=RPT; FAM=FOP=0; FRH=1; TRW=R; Remove_station; FA(monitor)=0
	207	FSL=0 & MS=TBN & TX_BN_TYPE=2	TX_BN_TYPE=3
	208	FSL=1 & FID=1 & MS=TBN	FID=0; FTI=1; TQP=R; TX_BN_TYPE=2; TXI(BN_PDU)
J68	209	FSL=1 & FINS=0 & FAM=0 & JS=RQI	JS=BPW; FDC=FNC=0
J48	210	FSL=1 & FAM=0 & JS=DAT	JS=BPW
J58	211	FSL=1 & FAM=0 & JS=NN	JS=BPW; FDC=0
M52	212	FSL=1 & FINS=1 & MS=RBN	MS=TCT; FCT=FID=0; FTXC=FTI=1; TCT=R; TQP=R; CCT=1; CCR=1; TXI(CT_PDU)
M62	213	FSL=1 & FINS=1 & MS=RCT	MS=TCT; FCT=0; FTXC=FTI=1; TCT=R; TQP=R; CCT=1; CCR=1; TXI(CT_PDU)
M02	214	FSL=1 & FINS=1 & MS=RPT	MS=TCT; FAM=FCT=0; FTXC=FTI=1; TCT=R; TQP=R; CCT=1; CCR=1; TXI(CT_PDU); FA(monitor)=0
M12	215	FSL=1 & FINS=1 & MS=TRP	MS=TCT; FAM=FCT=0; TCT=R; TQP=R; CCT=1; CCR=1; TXI(CT_PDU); FA(monitor)=0
	216	FSL=1 & MS=TBN	TX_BN_TYPE=2
	217	FTI=0	PS_CONTROL.request(Repeat_mode=Repeat)
	218	FTI=1	PS_CONTROL.request(Repeat_mode=Fill)
	219	FTW=1 & FRH=0 & MS=BNT	FOP=FTW=0; TRW=R; Remove_station
	220	FTXC=0	PS_CONTROL.request(Crystal_transmit=Not_asserted)
	221	FTXC=1	PS_CONTROL.request(Crystal_transmit=Asserted)
	222	INTERNAL_ERR(correctable) & MS=RPT & FINS=1 & FER=0	FER=1; TER=R; CIE=(CIE+1)
	223	INTERNAL_ERR(correctable) & MS=RPT & FINS=1 & FER=1 & CIE<255	CIE=(CIE+1)
J38	224	INTERNAL_ERR(not_correctable) & JS=ANM	JS=BPW
J48	225	INTERNAL_ERR(not_correctable) & JS=DAT	JS=BPW
J28	226	INTERNAL_ERR(not_correctable) & JS=DMP	JS=BPW
J78	227	INTERNAL_ERR(not_correctable) & JS=JC	JS=BPW; FINS=FJR=FDC=FNC=0
J58	228	INTERNAL_ERR(not_correctable) & JS=NN	JS=BPW; FDC=0
J68	229	INTERNAL_ERR(not_correctable) & JS=RQI	JS=BPW; FINS=FDC=FNC=0
	230	JS=BPW & FAM=1	[FAM=0; FA(monitor)=0 (optional)]
	231	JS=BPW & FOP=1	[FOP=0 (optional)]
	232	JS=BPW & MS<>RPT	[MS=RPT (optional)]
	233	M_UNITDATA.request & FJR=1 & FR_LTH<=MAX_TX	QUE_PDU
	234	M_UNITDATA.response & FTI=0 & TS=RPT	SET A=1
	235	M_UNITDATA.response & FR_COPIED & FTI=0 & TS=RPT	SET C=1
	236	MA_UNITDATA.request & FJR=1 & FR_LTH<=MAX_TX	QUE_PDU
	237	MGT_UNITDATA.request (SC<>RS) & FJR=1 & FR_LTH<=MAX_TX	QUE_PDU

**Table 7 — MAC Station Operation table (Continued)**

S/T	REF	Event/condition	Action/output
J28	238	PM_STATUS.indication(Medium_rate_error) & JS=DMP	JS=BPW
	239	PM_STATUS.indication(Signal_detection=Signal_acquired) & FSLD=1	FSL=FSLD=0
	240	PM_STATUS.indication(Signal_detection=Signal_loss) & FSLD=0	FSLD=1; TSL=R
	241	PM_STATUS.indication(Wire_fault=Detected) & FWFA=1 & FWF=0	FWF=1; TWF=R
	242	PM_STATUS.indication(Wire_fault=Not_detected) & FWF=1	FWF=0
	243	PS_STATUS.indication(Burst4_error)	[FSD=0 (optional-i)]
	244	PS_STATUS.indication(Frequency_error) & MS=RPT & FINS=1 & FER=0	FER=1; TER=R; CFE=(CFE+1)
	245	PS_STATUS.indication(Frequency_error) & MS=RPT & FINS=1 & FER=1 & CFE<255	CFE=(CFE+1)
	246	RCV_AC	STORE(Pr,Rr)
	247	RCV_ED	FMA=FNMA=FSD=0
T30A	248	RCV_ED & FSD=1 & FMA=1 & CFR=1 & TS=STRIP	TS=RPT; FTI=0
T30B	249	RCV_ED & FSD=1 & FMA=0 & CFR=1 & TS=STRIP	TS=RPT; FTI=0; FLF=1
	250	RCV_ED & FSD=1 & FED=1 & CFR>1	CFR=(CFR-1)
	251	RCV_SD	FMA=FNMA=0; FSD=1
	252	STATION_ERR(correctable) & TS=DATA & FINS=1 & MS=RPT & FER=0	FER=1; TER=R; CABE=(CABE+1)
	253	STATION_ERR(correctable) & TS=DATA & FINS=1 & MS=RPT & FER=1 & CABE<255	CABE=(CABE+1)
T10D	254	STATION_ERR(correctable) & TS=DATA & FTXI=0	TS=RPT; TX_AB
J38	255	STATION_ERR(not_correctable) & JS=ANM	JS=BPW
J48	256	STATION_ERR(not_correctable) & JS=DAT	JS=BPW
J78	257	STATION_ERR(not_correctable) & JS=JC	JS=BPW; FINS=FJR=FDC=FNC=0
J58	258	STATION_ERR(not_correctable) & JS=NN	JS=BPW; FDC=0
J68	259	STATION_ERR(not_correctable) & JS=RQI	JS=BPW; FINS=FDC=FNC=0
	260	TAM=E & FNN=0 & FAM=1 & MS=RPT	TAM=R; QUE_NN_INCOMP_PDU; QUE_AMP_PDU; LMP=(MAINULL)
	261	TAM=E & FNN=1 & FAM=1 & MS=RPT	FNN=0; TAM=R; QUE_AMP_PDU; LMP=(MAINULL)
M52	262	TBR=E & MS=RBN & FINS=1	MS=TCT; FCT=0; FTXC=FTI=1; TCT=R; TQP=R ; CCT=1; CCR=1; TXI(CT_PDU)
J68	263	TBT=E & MS=TBN & FINS=0 & JS=RQI	JS=BPW; FDC=FNC=0
M34	264	TBT=E & MS=TBN & FINS=1 & FBT=0	MS=BNT; FOP=0; FBT=1; TRW=R; Remove_station

**Table 7—MAC Station Operation table (Continued)**

S/T	REF	Event/condition	Action/output
J38	265	TCT=E & JS=ANM	JS=BPW
M63	266	TCT=E & MS=RCT & FNC=1	MS=TBN; FTXC=FTI=1; TBT=R; TQP=R ; TX_BN_TYPE=4; TXI(BN_PDU)
J48	267	TCT=E & MS=RCT & JS=DAT	JS=BPW
J58	268	TCT=E & MS=RCT & JS=NN	JS=BPW; FDC=0
J48	269	TCT=E & MS=TCT & JS=DAT	JS=BPW
J58	270	TCT=E & MS=TCT & JS=NN	JS=BPW; FDC=0
M23 B	271	TCT=E & MS=TCT & FNC=1 & FCT=0 & FSL=0	MS=TBN; TBT=R; TQP=R; TX_BN_TYPE=3; TXI(BN_PDU)
M23C	272	TCT=E & MS=TCT & FNC=1 & FSL=1	MS=TBN; TBT=R; TQP=R; TX_BN_TYPE=2; TXI(BN_PDU)
M23A	273	TCT=E & MS=TCT & FNC=1 & FCT=1 & FSL=0	MS=TBN; TBT=R; TQP=R; TX_BN_TYPE=4; TXI(BN_PDU)
	274	TER=E & FINS=1 & ERR_CNTR<>0	CER=1; QUE_RPRT_ERR_PDU
	275	TER=E & FINS=1 & FECO=1	TER=R
J10	276	TEST_FAILURE & JS=LT	JS=BP
J70	277	TEST_FAILURE & MS=BNT & JS=JC	JS=BP
J60	278	TEST_FAILURE & MS=BNT & JS=RQI	JS=BP
M45	279	TEST_OK & FBR=1 & MS=BNT	MS=RBN; FTI=FTXC=FWFA=FWF=0; FBT=FID=FOP=FRH=1; TWFD=R; TRH=R; TID=R; INSERT
M43	280	TEST_OK & FBT=1 & MS=BNT	MS=TBN; FTI=FWFA=FWF=0; FBR=FID=FOP=FRH=1; TID=R; TRH=R; TWFD=R; INSERT
J12	281	TEST_OK & JS=LT	JS=DMP; MS=RPT; TS=RPT; FTI=FTXC=0; FOP=FRH=1; TJR=R; TRH=R; SUA=0; INSERT
M52	282	TID=E & MS=RBN & FID=1	MS=TCT; FCT=FID=0; FTXC=FTI=1; TCT=R; TQP=R; CCT=1; CCR=1; TXI(CT_PDU)
	283	TID=E & MS=TBN & FID=1	FID=0; FTI=1; TQP=R; TXI(BN_PDU)
J48	284	TJR=E & JS=DAT	JS=BPW
J58	285	TJR=E & JS=NN	JS=BPW; FDC=0
J68	286	TJR=E & JS=RQI	JS=BPW; FINS=FDC=FNC=0
J23A	287	TJR=E & JS=DMP	JS=ANM; FANM=1

STANDARDS101.COM · Click to view the full PDF of ISO/IEC 8802-5:1995

**Table 7—MAC Station Operation table (Continued)**

S/T	REF	Event/condition	Action/output
	288	TK(M=0) & FAM=1 & FTHO=0	TVX=R; PS_EVENT.response(Token_received)
	289	TK(M=0) & FAM=1 & FTHO=1	FAT=1; PS_EVENT.response(Token_received)
M01	290	TK(M=1) & FAM=1 & MS=RPT	MS=TRP; FTI=1; TRP=R; TXI(RP_PDU)
	291	TK(M=1) & FAM=1 & MS=RPT & FINS=1 & FER=0	FER=1; TER=R; CTE=(CTE+1)
	292	TK(M=1) & FAM=1 & MS=RPT & FINS=1 & FER=1 & CTE<255	CTE=(CTE+1)
T01B	293	TK(P<=Pm) & PDU_QUEUED & FTI=0 & FOP=1 & TS=RPT	TS=DATA; FED=FMA=FSD=FTXI=0; CFR=1; CTO=(MAX_TX-FR_LTH); TX_SFS(P=Pr;R=0); LTA=TX_SA
	294	TK(P<>Sx) & PDU_QUEUED(P>Pm>R) & FTI=0 & TS=RPT & FOP=1	SET R=Pm
	295	TK_AC(P<Sx)	CLEAR_STACKS
	296	TK_AC(P=Sx) & Sr<Px & PDU_QUEUED(Pm<Sx) & FTI=0 & FOP=1 & TS=RPT	TX_TK(P=Px;M=0;R=0); RESTACK(Sx=Px)
	297	TK_AC(P=Sx) & Sr<Px & QUE_EMPTY & FTI=0 & FOP=1 & TS=RPT	TX_TK(P=Px;M=0;R=0); RESTACK(Sx=Px)
	298	TK_AC(P=Sx) & Sr>=Px & PDU_QUEUED(Pm<Sx) & FTI=0 & FOP=1 & TS=RPT	TX_TK(P=Sr;M=0;R=Px); POP(Sx;Sr)
	299	TK_AC(P=Sx) & Sr>=Px & QUE_EMPTY & FTI=0 & FOP=1 & TS=RPT	TX_TK(P=Sr;M=0;R=Px); POP(Sx;Sr)
	300	TK(P>0 & M=0) & FAM=1 & FTI=0 & TS=RPT	SET M=1
T10D	301	TK_ERR & FTXI=0 & TS=DATA	TS=RPT; TX_AB
	302	TK_ERR & TS=DATA & FINS=1 & FER=0	FER=1; TER=R; CABE=(CABE+1)
	303	TK_ERR & TS=DATA & FINS=1 & FER=1 & CABE<255	CABE=(CABE+1)
	304	TK_GOOD & FAM=0 & FGTO=1	TNT=R
	305	TK_GOOD(P=0) & FAM=0 & FGTO=0	TNT=R; FPT=0
	306	TK_GOOD(P>0) & FAM=0 & FGTO=0	FPT=1
	307	TK_WITH_ERR & FTEO=0 & FTI=0 & TS=RPT	SET E=1
	308	TK_WITH_ERR(E=0) & FTEO=0 & MS=RPT & FINS=1 & FER=0	FER=1; TER=R; CLE=(CLE+1)
	309	TK_WITH_ERR(E=0) & FTEO=0 & MS=RPT & FINS=1 & FER=1 & CLE<255	CLE=(CLE+1)
M02	310	TNT=E & FAM=0 & FINS=1 & MS=RPT	MS=TCT; FCT=0; FTXC=FTI=1; TCT=R; TQP=R; CCT=1; CCR=1; TXI(CT_PDU)
	311	TQP=E & MS=RPT & FDC=0 & FAM=0	FNW=1
	312	TQP=E & MS=RPT & FDC=1 & FAM=0	FNC=1; QUE_SMP_PDU
	313	TQP=E & MS=TBN & FID=0	TQP=R; TXI(BN_PDU)
	314	TQP=E & MS=TCT	TQP=R; CCT=(CCT+1); TXI(CT_PDU)
	315	TRH=E	FRH=0
	316	TRI=E & JS=RQI & CRI<n4	TRI=R; CRI=(CRI+1); QUE_RQ_INIT_PDU
J68	317	TRI=E & JS=RQI & CRI=n4	JS=BPW; FINS=FDC=FNC=0
J38	318	TRP=E & MS=TRP & JS=ANM	JS=BPW
J48	319	TRP=E & MS=TRP & JS=DAT	JS=BPW
J58	320	TRP=E & MS=TRP & JS=NN	JS=BPW; FDC=0
J68	321	TRP=E & MS=TRP & FINS=0 & JS=RQI	JS=BPW; FDC=FNC=0
M12	322	TRP=E & MS=TRP & FINS=1	MS=TCT; FAM=FCT=0; TCT=R; TQP=R; CCT=1; CCR=1; TXI(CT_PDU); QUE_ACT_ERR_PDU(EC=1); FA(monitor)=0

**Table 7—MAC Station Operation table (Continued)**

S/T	REF	Event/condition	Action/outout
T20	323	TRR=E & TS=FILL	TS=RPT; FTI=0; FLF=1
T30C	324	TRR=E & TS=STRIP	TS=RPT; FTI=0; FLF=1
J80	325	TRW=E & JS=BPW	JS=BP; FTI=x
	326	TRW=E & MS=BNT	FTXC=1; FTI=x; TEST
T23A	327	TS=FILL & FMA=0 & FETO=1 & FMRO=1 & Pr=Sx & Sr<Px	TS=STRIP; TX_TK(P=Px;M=0;R=0); RESTACK(Sx=Px)
T23A	328	TS=FILL & FMA=0 & FETO=1 & FMRO=1 & Pr=Sx & Sr>=Px	TS=STRIP; TX_TK(P=Sr;M=0;R=Px); POP(Sx;Sr)
T23A	329	TS=FILL & FMA=0 & FETO=1 & FMRO=1 & Pr>Sx & Pr<Px	TS=STRIP; TX_TK(P=Px;M=0;R=0); STACK(Sx=Px;Sr=Pr)
T23A	330	TS=FILL & FMA=0 & FETO=1 & FMRO=1 & Pr>Sx & Pr>=Px	TS=STRIP; TX_TK(P=Pr;M=0;R=Px)
T23A	331	TS=FILL & FMA=1 & Pr=Sx & Sr<Px	TS=STRIP; TX_TK(P=Px;M=0;R=0); RESTACK(Sx=Px)
T23A	332	TS=FILL & FMA=1 & Pr=Sx & Sr>=Px	TS=STRIP; TX_TK(P=Sr;M=0;R=Px); POP(Sx;Sr)
T23A	333	TS=FILL & FMA=1 & Pr>Sx & Pr<Px	TS=STRIP; TX_TK(P=Px;M=0;R=0); STACK(Sx=Px;Sr=Pr)
T23A	334	TS=FILL & FMA=1 & Pr>Sx & Pr>=Px	TS=STRIP; TX_TK(P=Pr;M=0;R=Px)
	335	TSL=E & FSLD=1	FSL=1
M02	336	TSM=E & MS=RPT & FINS=0 & FAM=1	MS=TCT; FAM=FCT=0; FTXC=FTI=1; TCT=R; TQP=R; CCT=1; CCR=1; TXI(CT_PDU); FA(monitor)=0
M02	337	TSM=E & MS=RPT & FINS=1	MS=TCT; FAM=FCT=0; FTXC=FTI=1; TCT=R; TQP=R; CCT=1; CCR=1; TXI(CT_PDU); FA(monitor)=0
M01	338	TVX=E & FTHO=0 & FAM=1 & MS=RPT	MS=TRP; FTI=1; TRP=R; TXI(RP_PDU)
	339	TVX=E & FTHO=0 & FAM=1 & MS=RPT & FINS=1 & FER=0	FER=1; TER=R; CTE=(CTE+1)
	340	TVX=E & FTHO=0 & FAM=1 & MS=RPT & FINS=1 & FER=1 & CTE<255	CTE=(CTE+1)
M01	341	TVX=E & FTHO=1 & FAT=0 & FAM=1 & MS=RPT	MS=TRP; FTI=1; TRP=R; TXI(RP_PDU)
	342	TVX=E & FTHO=1 & FAT=0 & FAM=1 & MS=RPT & FINS=1 & FER=0	FER=1; TER=R; CTE=(CTE+1)
	343	TVX=E & FTHO=1 & FAT=0 & FAM=1 & MS=RPT & FINS=1 & FER=1 & CTE<255	CTE=(CTE+1)
	344	TVX=E & FTHO=1 & FAT=1 & FAM=1	FAT=0; TVX=R
J78	345	TWF=E & FWFA=1 & FWF=1 & MS<>BNT & JS=JC	JS=BPW; FINS=FJR=FDC=FNC=0
	346	TWFD=E & FWFA=0	FWFA=1
	347	TX_ERR(DAT) & JS=DAT	QUE_DAT_PDU
	348	TX_ERR(RP) & MS=TRP	TXI(RP_PDU)
	349	TX_ERR(RPRT_ERR) & CER<n3 & FOP=1	QUE_RPRT_ERR_PDU; [CER=CER+1 (optional)]
	350	TX_ERR(RQ_INIT) & JS=RQI & FOP=1	QUE_RQ_INIT_PDU
	351	TX_ERR(SUA_CHG) & CSC<n3 & FOP=1	QUE_SUA_CHG_PDU; [CSC=CSC+1 (optional)]
T01	352	TXI_REQ & TS=RPT	TS=DATA; FTI=0; FTXI=1; TX_SFS(P=0;R=0)

### 4.3.5 Precise specification of terms

#### 4.3.5.1 Precise specification of events/conditions

The following definitions are applied to the terms used for events in the FSMs and Station Operation table.

Unless otherwise specified, the following terms and operations are defined:

**{term1} = {term2}**. Term 1 is equal to term 2.  
**{term1} < {term2}**. Term 1 is less than term 2.  
**{term1} <= {term2}**. Term 1 is less than or equal to term 2.  
**{term1} > {term2}**. Term 1 is greater than term 2.  
**{term1} >= {term2}**. Term 1 is greater than or equal to term 2.  
**{term1} <> {term2}**. Term 1 is not equal to term 2.  
**{flag}=0**. The specified flag is set to zero (false).  
**{flag}=1**. The specified flag is set to one (true).  
**{timer}=E**. The specified timer has expired.  
Items in parentheses ( ) are grouped to show relevance.  
& means "and".  
| means "or".

**A=0**. Both the A bits in the received frame's FS field (bits 0 and 4) were 0.

**A=1**. Both the A bits in the received frame's FS field (bits 0 and 4) were 1.

**A<>1**. Either or both A bits in the received frame's FS field (bits 0 and 4) were 0.

**A|C<>0**. At least one of the frame status bits in the received frame's FS field (bits 0,1,4, or 5) is 1.

**A|C<>1**. At least one of the frame status bits in the received frame's FS field (bits 0,1,4, or 5) is 0.

**BN\_TYPE**. The value of the beacon type subvector received.

**Burst5\_error\_event**. A conditional PM\_STATUS.indication(Burst5\_error) has occurred. The conditions under which a Burst5\_error is excluded is not uniquely specified by this standard (see 3.6.3). At a minimum, the station shall include the first Burst5\_error following a valid MAC frame copied by the station if the Burst5\_error occurs within a frame. The station may include every Burst5\_error.

**C=0**. Both the C bits in the received frame's FS field (bits 1 and 5) were set to 0.

**C=1**. Both the C bits in the received frame's FS field (bits 1 and 5) were set to 1.

**C<>0**. Either or both C bits in the received frame's FS field (bits 1 and 5) were set to 1.

**Connect.MAC**. The MAC receives the command from management to start the connection process to join the ring.

**CORR\_NOT\_PRESENT**. The received frame did not contain a correlator subvector.

**CORR\_PRESENT**. The received frame did contain a correlator subvector.

**CTO-FR\_LTH<0**. The value of the Transmit Octet counter is less than the next frame length to be transmitted.

**CTO-FR\_LTH>=0**. The value of the Transmit Octet counter is greater than, or equal to, the next frame length to be transmitted.

**DA=any\_recognized\_address**. The DA of the received frame matches any of the station's addresses as follows:

- Is the station's individual address (DA=MA), or
- Is one of the station's group addresses, or
- Is one of the station's functional addresses, or
- Is one of the broadcast addresses as defined in 3.2.4.1.

**DA=MA**. The DA of the received frame is equal to the individual address of the station. If the station's individual address is a universally administered address, then all 48 bits must match. If the station's individual address is a locally administered address, then either a hierarchical address match or a 48-bit address match is allowed.

**DA=Non\_broadcast**. The received frame was not sent to a broadcast address, but otherwise addressed to the station.

**Disconnect.MAC.** The request from local management to remove the station from the ring.

**E=0.** The error bit in the received ED field is zero.

**E=1.** The error bit in the received ED field is one.

**EOD.** End of data: The last octet of the Information field has been transmitted.

**ERR\_CNTR<>0.** Any error counter not zero.

**ERR\_COND=LONG\_MAC.** MAC frame too long—INFO field larger than maximum allowed VL value.

**ERR\_COND=SC\_INVALID.** Invalid source class.

**ERR\_COND=SHORT\_MAC.** MAC frame not long enough to contain VL, VC, and VI fields.

**ERR\_COND=SV\_LTH\_ERR.** Subvector length error.

**ERR\_COND=SV\_MISSING.** Missing required subvector.

**ERR\_COND=SV\_UNK.** Unknown subvector SVI value.

**ERR\_COND=VI\_LTH\_ERR.** Vector length error. VL is not equal to the sum of all the SVLs plus the length of VL, VC, and VI fields, or VL does not agree with the length of the frame.

**ERR\_COND=VI\_UNK.** Unrecognized vector ID value.

**FR.** A frame has been received that meets the criteria specified in 4.3.2.

**FR(criteria).** A frame has been received that meets the specified criteria and the criteria specified in 4.3.2.

**FR\_AC(criteria).** A frame's access control field has been received that meets the specified criteria and the criteria specified in 4.3.2.

**FR\_AMP(criteria).** A verified Active Monitor Present frame (3.3.5.2) is received that meets the specified criteria.

**FR\_BN(criteria).** A verified Beacon frame (3.3.5.2) is received that meets the specified criteria.

**FR\_CHG\_PARM(criteria).** A verified Change Parameters MAC frame (3.3.5.2) is received that meets the specified criteria.

**FR\_BN\_CIR.** A frame's access control field has been detected with the M bit set to 1 indicating a circulating frame. The method used to detect this condition is outside the scope of this standard, but reception of a valid beacon frame (3.3.5.2) with the M bit set to 1 shall satisfy this condition.

**FR\_COPIED(criteria).** The MAC successfully copied the received frame that meets the specified criteria.

**FR\_CT(criteria).** A verified Claim Token MAC frame (3.3.5.2) is received that meets the specified criteria.

**FR\_DAT(criteria).** A verified DAT MAC frame (3.3.5.2) is received that meets the specified criteria.

**FR\_INIT(criteria).** A verified Initialize Station MAC frame (3.3.5.2) is received that meets the specified criteria.

**FR\_LLC(criteria).** An LLC frame is received that meets the specified criteria and the criteria specified in 4.3.2.

**FR\_LTH.** The length of the frame to be transmitted. The value for the frame length includes all of the frame format fields beginning with the starting delimiter (SD) and including the interframe gap (IFG).

**FR\_LTH<=MAX\_TX.** The length of the frame to be transmitted is less than or equal to the maximum allowed frame length.

**FR\_MAC(criteria).** A valid MAC frame is received that meets the specified criteria and the criteria specified in 4.3.2.

**FR\_MAC\_INV(criteria).** An invalid MAC frame (3.3.5.2) is received that meets the specified criteria.

**FR\_NOT\_COPIED.** The station sets the A bits (ref 040 or 234) but does not copy the frame.

**FR\_REMOVE(DA=Non\_broadcast).** A verified Remove MAC frame (3.3.5.2) is received, not sent to a broadcast address, but otherwise addressed to the station.

**FR\_RP(criteria).** A verified Ring Purge MAC frame (3.3.5.2) is received that meets the specified criteria.

**FR\_RPRT\_ERR(criteria).** A Report Error MAC frame (3.3.5.1) is received that was transmitted by the station without error (4.3.3) and that meets the specified criteria.

**FR\_RQ\_ADDR.** A verified Request Address MAC frame (3.3.5.2) is received.

**FR\_RQ\_ATTACH.** A verified Request Attachment MAC frame (3.3.5.2) is received.

**FR\_RQ\_INIT(criteria).** A Request Initialization MAC frame (3.3.5.1) is received that was transmitted by the station without error (4.3.3) and that meets the specified criteria.

**FR\_RQ\_STATE.** A verified Request Station State MAC frame (3.3.5.2) is received.

**FR\_SMP(criteria)**. A verified SMP MAC frame (3.3.5.2) is received that meets the specified criteria.

**FR\_SUA\_CHG(criteria)**. A Report SUA Change MAC frame (3.3.5.1) is received that was transmitted by the station without error (4.3.3) and meets the specified criteria.

**FR\_WITH\_ERR**. A frame is received with errors (see 4.3.2).

**FR\_WITH\_ERR(criteria)**. A frame is received with errors (see 4.3.2) that meets the specified criteria.

**INTERNAL\_ERR**. Any internal error occurred that prevented the station from following the established protocol (i.e., parity error, etc.).

**JS=state**. The Join State is in the specified state.

**LTA**. The stored SA field from the last transmitted frame.

**M=0**. The Monitor bit in the AC field is received as zero.

**M=1**. The Monitor bit in the AC field is received as one.

**M\_UNITDATA.request**—The bridge interface requests a frame be transmitted.

**M\_UNITDATA.response**—The optional indication from the bridge interface in response to an M\_UNITDATA.indication that requests setting of the A and C bits.

**MA\_UNITDATA.request**—The LLC interface requests a frame be transmitted.

**MGT\_UNITDATA.request**—The management interface requests a frame be transmitted.

**MAX\_TX**. The maximum number of octets that may be transmitted (including fill) after capturing the token as specified in 4.2.4.1, Counter, Transmitted Octets (CTO).

**MS=state**. The Monitor State is in the specified state.

**P**. Value of P bits in AC field.

**P>Pm>R**. A token or frame is received and the priority of the PDU queued for transmission is greater than the received reservation (R) but less than the current service priority (P).

**PM\_STATUS.indication(Signal\_detection=Signal\_acquired)**. The PHY indicates valid receiver signal (see 5.1.4.1).

**PM\_STATUS.indication(Signal\_detection=Signal\_loss)**. The PHY indicates loss of valid receiver signal (see 5.1.4.1).

**PM\_STATUS.indication(Wire\_fault=Detected)**. The PHY indicates a wiring fault (see 5.1.4.1).

**PM\_STATUS.indication(Wire\_fault=Not\_detected)**. The PHY indicates no wiring fault (see 5.1.4.1).

**PDU\_QUEUED**. A frame is queued for transmission.

**PDU\_QUEUED(criteria)**. A frame is queued for transmission that meets the specified criteria. Note that a queued PDU is transmitted when a token is received with a priority less than or equal to the priority of the queued PDU (Pm). Frames that do not wait for a token are not queued but are indicated by TXI\_REQ.

**PS\_STATUS.indication(Frequency\_error)**. The station indicates the frequency of the received data is out of tolerance (see 5.1.2.3).

**PS\_STATUS.indication(Medium\_rate\_error)**. The station indicates the frequency of the received data is not the selected rate (see 5.1.2.3).

**PS\_STATUS.indication(Burst4\_error)**. The station indicates the received data contains a Burst4\_error (see 5.1.2.3).

**PS\_STATUS.indication(Burst5\_error)**. The station indicates the received data contains a Burst5\_error (see 5.1.2.3).

**Pm**. The priority of the queued PDU. If no PDU is queued, Pm is assumed to have a value of zero.

**Px**. A priority value representing the higher value of either (a) the received reservation or (b) the priority of the frame queued for transmission.  
If PDU\_QUEUED and Pm>Rr then Px=Pm  
Else Px=Rr.

**QUE\_EMPTY**. No frames are queued for transmission.

**QUE\_NOT\_EMPTY**. Another PDU is queued for transmission.

**R**. Value of R bits in AC field.

**RCV\_AC**. The Access Control field is received.

**RCV\_ED**. An ending delimiter (PS\_STATUS.indication(Ending\_delimiter) see 5.1.2.3) is received.

**RCV\_SD**. A starting delimiter (PS\_STATUS.indication(Starting\_delimiter) see 5.1.2.3) is received.

- RCV(SA<>LTA).** The source address of the received frame is not the same as the source address of the last frame transmitted by this station. This condition requires that no code violations are present in the SA field and optionally any of the preceding fields.
- RCV(SA=LTA).** The source address of the received frame is the same as the source address of the last frame transmitted by this station. The station is not required to, but may check for code violations in the SA or any preceding field to determine the validity of this event.
- SA<>MA.** The value of the source address (SA) of the received frame is not equal to the individual address of the station.
- SA<>SUA.** The source address (SA) of the received frame is not the same as the address stored as the upstream neighbor's address (SUA).
- SA<MA.** The value of the source address (SA) of the received frame is numerically less than the individual address of the station. For purpose of comparison, first bit received is most significant.
- SA>MA.** The value of the source address (SA) of the received frame is numerically greater than the individual address of the station. For purpose of comparison, first bit received is most significant.
- SA=MA.** The value of the source address (SA) of the received frame is equal to the individual address of the station.
- SA=SUA.** The source address (SA) of the received frame is the same as the address stored as the upstream neighbor's address (SUA).
- SC\_NOT\_PRESENT.** The MAC frame is too short to contain the source class.
- SC\_PRESENT.** The MAC frame does contain the source class.
- SC<>RS.** The source class is not 0 (Ring Station).
- SC=CRS.** The source class is 4 (Configuration Report Server)
- SC=RPS.** The source class is 5 (Ring Parameter Server).
- STATION\_ERR.** Any internal condition which prevents the successful completion of the PDU transmit operation.
- TEST\_FAILURE.** The station failed its self test.
- TEST\_OK.** The station passed its self test.
- TK.** A token is received that meets the criteria specified in 4.3.1.
- TK(criteria).** A token is received that meets the specified criteria and the criteria specified in 4.3.1.
- TK\_AC(criteria).** A token is received that meets the specified criteria and the criteria specified in 4.3.1.
- TK\_GOOD.** A good token is received that meets the criteria specified in 4.3.1.
- TK\_GOOD(criteria).** A good token is received that meets the specified criteria and the criteria specified in 4.3.1.
- TK\_ERR.** The token is not valid (see 4.3.1).
- TK\_WITH\_ERR.** A token is received that contains errors (see 4.3.1).
- TK\_WITH\_ERR(criteria).** A token is received that contains errors (see 4.3.1) that meets the specified criteria.
- TS=state.** The transmit state is in the specified state.
- TX\_BN\_TYPE.** The value of the beacon type subvector being transmitted.
- TX\_ERR(DAT).** During the transmission of the DAT MAC frame, a transmission error is encountered (see 4.3.3).
- TX\_ERR(RP).** During the transmission of the Ring Purge MAC frame, a transmission error is encountered (see 4.3.3).
- TX\_ERR(RPRT\_ERR).** During the transmission of the RPRT\_ERR MAC frame, a transmission error is encountered (see 4.3.3).
- TX\_ERR(RQ\_INIT).** During the transmission of the Request Initialization MAC frame, a transmission error is encountered (see 4.3.3).
- TX\_ERR(SUA\_CHG).** During the transmission of the Report SUA Change MAC frame, a transmission error is encountered (see 4.3.3).
- TXI\_REQ.** A frame is requested to be transmitted without waiting for a token. This request is generated by the TXI(frame\_type) action (e.g., TXI(BN\_PDU)).
- UNA.** The upstream neighbor's address (UNA) subvector in the received frame.
- UNA<>MA.** The reported upstream neighbor's address (UNA) in the received frame is not equal to the station's individual address.

**UNA<>SUA.** The value of the reported upstream neighbor's address (UNA) in the received frame is not the same as the stored upstream address (SUA).

**UNA=MA.** The reported upstream neighbor's address (UNA) in the received frame is equal to the station's individual address.

**UNA=SUA.** The value of the received reported upstream neighbor's address (UNA) is the same as the stored upstream address (SUA).

#### 4.3.5.2 Precise specification of actions

The following definitions are applied to the terms used for actions in the FSMs and table 7. Actions are separated by a semicolon (;).

Unless otherwise specified, the following operations are defined:

**variable = value.** Set the variable to the specified value.  
**{counter}={counter}+1.** Increment the specified counter.  
**{counter}={counter}-1.** Decrement the specified counter.  
**{counter}=value.** Set the specified counter to the specified value.  
**{flag}=0.** Set the value of the specified flag to zero (false).  
**{flag}=1.** Set the value of the specified flag to one (true).  
**{timer}=R.** The specified timer will be set to its initial value and started.

**A=0.** Both A bits in the FS field shall be transmitted as zero.

**A=1.** Both A bits in the FS field shall be set to one as the frame is repeated.

**C=0.** Both C bits in the FS field shall be transmitted as zero.

**C=1.** Both C bits in the FS field shall be set to one as the frame is repeated.

**CLEAR\_STACKS.** The station shall clear all stacked values for Sx and Sr (i.e., the list is empty and the effective value of Sx and Sr is -1). The station shall no longer be responsible for lowering the ring priority.

**CTO=CTO-FR\_LTH.** The value of the Transmit Octet counter is decreased by the number of octets (frame length) of the frame to be transmitted. The value for the frame length includes all of the frame format fields beginning with the starting delimiter (SD) and including the interframe gap (IFG). This correlates to the counter CTO being decremented every 8 bits after the capture of the token.

**CTO=MAX\_TX-FR\_LTH.** The value of the Transmit Octet counter is set to the value of the maximum frame length in octets less the number of octets (frame length) of the frame to be transmitted. The value for the frame length includes all of the frame format fields beginning with the starting delimiter (SD) and including the interframe gap (IFG).

**CORR=RCV\_CORR.** The value of the correlator subvector will be the same value as the received correlator subvector.

**CORR=UNK\_VALUE.** The value of the correlator subvector is unspecified and the correlator subvector may be omitted (3.3.4).

**DC=CRS.** The value of the destination class is 4 (Configuration Report Server).

**DC=RCV\_SC.** The destination class field DC shall contain the value of the source class field (SC) of the received frame.

**DC=RPS.** The value of the destination class is 5 (Ring Parameter Server).

**DC<>RS.** The destination class field DC shall not be 0. Note that the source class field (SC) of the received frame was not present and thus the destination class of the response frame is not defined but shall not be the ring station class.

**E=0.** The error (E) bit in the ending delimiter (ED) field shall be transmitted as zero.

**E=1.** The error (E) bit in the ending delimiter (ED) field shall be set to one as the frame is repeated.

**FA(monitor)=0.** Disable the functional address corresponding to the active monitor function.

**FA(monitor)=1.** Enable the functional address corresponding to the active monitor function.

**FTI=x.** The value of FTI is not specified.

**INSERT.** Request the PHY to physically connect the station into the ring [5.1.4.2 PM\_CONTROL.request(Insert\_station)].

**JS=state.** The join state is changed to the specified state.

**LTA=TX\_SA.** Capture the source address (SA) of the last transmitted frame as variable LTA.

**LMP=(MA|NULL).** The address for the Last Monitor Present frame (X'0A' subvector 3.3.4) is set to either the station's address or the null address.

**LMP=NULL.** The address for the Last Monitor Present frame (X'0A subvector 3.3.4) is the null address.

**LMP=SA.** The SA is saved for reporting the address of the Last Monitor Present frame (X'0A' subvector 3.3.4).

**M=0.** The station shall transmit the monitor bit (M) in the AC field as a zero.

**M=1.** The station shall set the monitor bit (M) in the received AC field to one as the AC field is repeated.

**M\_UNITDATA.indication**—The frame is indicated to the bridge interface.

**MA\_UNITDATA.indication**—The frame is indicated to the LLC interface.

**MGT\_UNITDATA.indication**—The frame is indicated to the management interface.

**MS=state.** The monitor state is changed to the specified state.

**P.** The value of the P bits in the AC field.

**Pm.** The priority of the PDU being queued.

**Pr.** The value of the P bits in the last received AC field.

**PM\_CONTROL.request(Insert\_station).** The MAC requests the station be inserted into the ring (see 5.1.4.2).

**PM\_CONTROL.request(Remove\_station).** The MAC requests the station be removed from the ring (see 5.1.4.2).

**POP(Sx,Sr).** Remove the last values of Sx and Sr from the list of stacked priorities on the Sx and Sr stacks.

**PS\_CONTROL.request(Crystal\_transmit=Asserted).** The MAC requests Crystal\_transmit (see 5.1.2.4).

**PS\_CONTROL.request(Crystal\_transmit=Not\_asserted).** The MAC removes the Crystal\_transmit request (see 5.1.2.4).

**PS\_CONTROL.request(Repeat\_mode=Fill).** The MAC requests the station sources fill (see 5.1.2.4).

**PS\_CONTROL.request(Repeat\_mode=Repeat).** The MAC requests the station repeat (see 5.1.2.4).

**PS\_EVENT.response(Token\_received).** The MAC indicates token received (see 5.1.2.5).

**QUE\_ACT\_ERR\_PDU(EC=value).** Queue a Report Active Monitor Error MAC PDU as defined in 3.3.5.1 for transmission with the specified error code (EC).

**QUE\_AMP\_PDU.** Queue an Active Monitor Present (AMP) MAC PDU as defined in 3.3.5.1 for transmission.

**QUE\_DAT\_PDU.** Queue a Duplicate Address Test (DAT) MAC PDU as defined in 3.3.5.1 for transmission.

**QUE\_PDU.** Queue the PDU for transmission.

**QUE\_NEW\_MON\_PDU.** Queue a Report New Active Monitor MAC PDU as defined in 3.3.5.1 for transmission.

**QUE\_NN\_INCMP\_PDU.** Queue a Report Neighbor Notification Incomplete MAC PDU as defined in 3.3.5.1 for transmission.

**QUE\_RPRT\_ADDR\_PDU.** Queue a Report Station Addresses MAC PDU as defined in 3.3.5.1 for transmission.

**QUE\_RPRT\_ATTCH\_PDU.** Queue a Report Station Attachment Report Attachment MAC PDU as defined in 3.3.5.1 for transmission.

**QUE\_RPRT\_ERR\_PDU.** Queue a Report Error MAC PDU as defined in 3.3.5.1 for transmission.

**QUE\_RPRT\_STATE\_PDU.** Queue a Report Station State MAC PDU as defined in 3.3.5.1 for transmission.

**QUE\_RQ\_INIT\_PDU.** Queue a Request Initialization MAC PDU as defined in 3.3.5.1 for transmission.

**QUE\_RSP\_PDU.** Queue a Response MAC PDU as defined in 3.3.5.1 for transmission. This PDU is not required to be queued if the received frame initiating the response was sent to a broadcast address and the address-recognized and frame-copied bits in the Frame Status field were all ones.

**QUE\_SMP\_PDU.** Queue a Standby Monitor Present MAC PDU as defined in 3.3.5.1 for transmission.

**QUE\_SUA\_CHG\_PDU.** Queue a SUA Change MAC PDU as defined in 3.3.5.1 for transmission.

- R.** The value of the R bits in the AC field.
- Rr.** The value of the R bits in the last received AC field.
- R=Pm.** Set the reservation bits (R) in the AC field to the value of the queued PDU.
- RESET\_STACKS(Sx=P; Sr=0).** The station clears all stacked values for Sx and Sr and then adds the new Sx and Sr values.
- RESTACK(Sx=P<sub>x</sub>).** Replace the last value of stack Sx with P<sub>x</sub> (the value of P bits of the token to be transmitted).
- Remove\_station.** Request the PHY to physically disconnect the station from the ring [5.1.4.2 PM\_CONTROL.request(Remove\_station)].
- RSP\_TYPE=value.** The Response Code subvector shall have the hexadecimal value specified.
- SC=RS.** The Source Class field (SC) shall contain the value zero (Ring Station).
- SET <field> = <value>.** When the MAC repeats the field, it will set the field to the specified value (see M=1, R=Pm, E=1, A=1, and C=1).
- SET APPR\_PARMS.** The station shall set the station's parameters to the values indicated in the received frame.
- SET ERR\_CNTR to 0.** Set the values for all of the error counters reported in the Report Error MAC frame to zero.
- Set\_initial\_conditions.** The station shall set all MAC flags to zero, set all MAC counters to zero, and stop all timers. The Monitor FSM and Transmit FSM are not specified. The PS\_CONTROL.request(Medium\_rate) and PM\_CONTROL.request(Medium\_rate) shall indicate to the PHY the value of FMRO.
- STACK(Sx=P<sub>x</sub>; Sr=Pr).** Add the new Sx and Sr values to the list of stacked priorities on the Sx and Sr stacks.
- STORE(Pr; Rr).** Save the value of P and R in the received AC field as Pr and Rr, respectively.
- SUA=0.** Store the null address as the station's SUA.
- SUA=SA.** Store the value of the SA from the received frame as the station's SUA.
- TEST.** The station shall perform a test of its transmit functions, its receive functions, and the medium between the station and the TCU. It is recommended that the data path includes the elastic buffer and the fixed latency buffer (5.8). A station shall fail the test if the sustained bit error rate is greater than 10<sup>-6</sup>. A station shall only transmit valid frames, tokens, and fill during the test and shall only count errors in frames and tokens.
- TS=state.** The transmit state is changed to the specified state.
- TX\_AB.** The station shall transmit an abort delimiter.
- TX\_BN\_TYPE.** The value of the beacon type subvector to be transmitted.
- TX\_EFS(I=0).** The station shall transmit an EFS composed of ED, FS, and IFG fields. The E,I,A, and C bits shall be zero.
- TX\_EFS(I=x).** The station shall transmit an EFS composed of ED, FS, and IFG fields. The I bit may be zero or one, and the E,A, and C bits shall be zero.
- TX\_FCS.** The station shall transmit FCS for the frame as defined in 3.2.7.
- TX\_SFS(P=value; M=0; R=value).** The station shall transmit the SFS with the priority and reservation values as specified. The token busy bit (T) shall be one and the monitor bit (M) shall be zero.
- TX\_TK(P=value; M=0; R=value).** The station shall transmit a token with the priority and reservation fields as specified. The monitor (M) bit and the token busy (T) bit shall be transmitted as zero.
- TXI(BN\_PDU).** The station shall transmit a Beacon MAC frame with the AC field values of P=000, T=1, M=0, R=000. The frame shall contain all of the required subvectors. The transmission of the frame shall occur at the earliest opportunity (after completion of any transmission in progress) and not wait for a token. This action generates the TXI\_REQ event.
- TXI(CT\_PDU).** The station shall transmit a Claim Token MAC frame with the AC field values of P=000, T=1, M=0, R=000. The frame shall contain all of the required subvectors. The transmission of the frame shall occur at the earliest opportunity (after completion of any transmission in progress) and not wait for a token. This action generates the TXI\_REQ event.
- TXI(RCV\_CT\_PDU).** The station shall transmit the received Claim Token MAC frame as received with the AC field values of P=000, T=1, M=0, R=000. The transmission of the frame shall occur at the

earliest opportunity (after completion of any transmission in progress) and not wait for a token. This action generates the TXI\_REQ event.

**TXI(RP\_PDU).** The station shall transmit a Ring Purge MAC frame with the AC field values of P=000, T=1, M=0, R=000. The frame shall contain all of the required subvectors. The transmission of the frame shall occur at the earliest opportunity (after completion of any transmission in progress) and not wait for a token. This action generates the TXI\_REQ event.

STANDARDSISO.COM : Click to view the full PDF of ISO/IEC 8802-5:1995

## 5. Station specific components

### 5.1 General

The station's physical layer (PHY) is divided into two sublayers: physical signaling components (PSC) and physical medium components (PMC). This clause describes the operation of the station's PSC. The components described in this clause provide the physical coupling between the Medium Access Control (MAC) protocol and the physical media components (PMC).

This clause defines the signal processing and system level physical layer (PHY) signaling specifications (independent of the medium type) that are specific to a ring station. These station specific component specifications include symbol timing, symbol encoding/decoding, latency, and burst error detection/correction. The specifications in this clause are generic for all media types. Frame formats are defined in clause 3 and the MAC protocol is specified in clause 4. The specifics for the PMC, which include the receiver, clock recovery, ring access control, and transmitter, are covered in clause 7.

This clause addresses the PSC that couple the PMC to the MAC and, for the purpose of specifying operation, defines the service boundaries to the PMC and to the MAC. The definition of these components are solely for the purpose of specifying operation and do not imply any particular implementation. The operation specified in this clause requires the MAC protocol and shall not be considered appropriate operation for devices that do not contain a MAC. Devices that do not support the MAC protocol (e.g., repeaters) are subject for future standardization. This clause requires that any station that modifies the data stream (e.g., perform burst error correction) shall conform to the MAC protocol, except that a device not implementing the MAC protocol may modify a data stream containing a burst6 so long as the resulting data stream has only that burst modified, and the resultant is a burst5.

#### 5.1.1 Overview

Figure 26 shows an example of a station's data path and illustrates the service interface to the MAC and PMC.

The term used for the element of data transfer between the MAC and the differential Manchester encoder/decoder is "symbol." A symbol is characterized by one of the values of Data\_zero, Data\_one, Non-data\_J, Non-data\_K. The term used for the element of data transfer between components in the PHY is "signal element." A signal element is characterized solely by its polarity (Logic\_0, Logic\_1) and thus two (2) signal elements are required to represent a single symbol.

The signaling method used to send data to the ring is differential Manchester, which contains both data and timing reference information. This signaling method permits a station to recover timing information from the received data signals. Timing information recovery is specified in clause 7. When the station is not transmitting and not in recovery, it is normally repeating the received data. The repeat path inspects the received data for invalid signal patterns. By the nature of differential Manchester coding, with the pairing of Non-data\_J and Non-data\_K symbols, and in the absence of errors, there should never be more than 3 signal elements received in succession with the same polarity. The reception of 4 consecutive signal elements with the same polarity (burst4) is a coding error that indicates the potential loss of data and timing information. When more than 4 signal elements are received with the same polarity (burst5), the station introduces transitions into the repeated data such that only 4 signal elements are repeated with the same polarity. The station continues to introduce transitions until a transition is received. One common source of burst errors is caused by a TCU when a station is inserted or removed from the ring. The source of the burst5 is isolated by changing the burst5 into a burst4. Thus only the first station after the source of the burst condition reports it. The burst4 propagates around the ring as an indication that data has been corrupted. Note that certain physical characteristics may cause a burst4 repeated by one station to be

detected as a burst5 at the next station and thus becomes a potential source for reported burst errors. The MAC protocol is notified of burst errors both for the purpose of isolation/reporting the error and also reducing over-stripping (miss-counting of transmitted frames) when two or more frames are concatenated into a single frame when a burst error destroys the ending delimiter of one frame and the starting delimiter of the next.

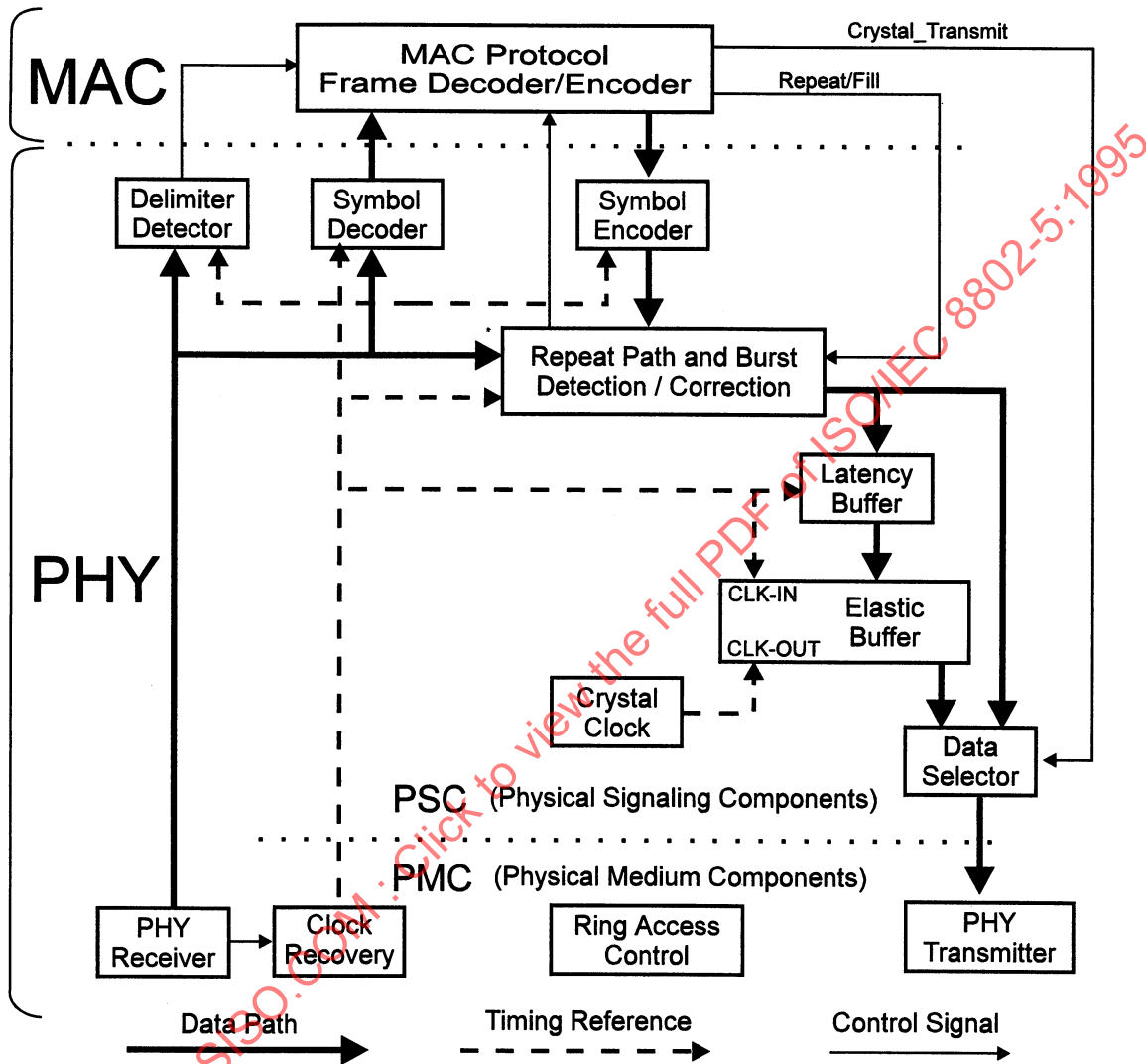

Figure 26—Station data path example

The received data is also sent to the Symbol Decoder where it is inspected for Starting Delimiter (SD) and Ending Delimiter (ED) patterns. When a delimiter is detected, the delimiter event is indicated to the MAC and the decoding of the received data stream is synchronized such that for every 2 signal elements, a symbol (Data\_zero, Data\_one, Non-data\_J, Non-data\_K) is indicated to the MAC protocol.

The MAC protocol controls the repeat path such that received data is normally repeated at the station's output except when the MAC protocol interrupts the repeat path forcing either fill or data (frames and tokens) to be transmitted. The phrase "repeated data" means that a transition on the input results in a transition on the output independent of the polarity of either the input or output signals. The symbol encoder allows the MAC protocol to modify individual symbols as they are being repeated and source symbols creating frames and tokens.

The MAC protocol requests repeat, fill, or symbols (Data\_zero, Data\_one, Non-data\_J, Non-data\_K) to the PSC. The symbol encoder converts each symbol to differential Manchester code to be transmitted. Differential Manchester code is characterized by the relationship of the signal element value to the value of the previous signal element. The symbol encoder operates by creating or removing the transitions between signal elements.

The fixed latency buffer and elastic buffer are inserted in the data path when requested by the MAC protocol to provide 1) the latency required to assure that an entire token can exist within the total ring latency and 2) an elastic buffer to allow the station's output to be timed from a fixed frequency reference (crystal clock). One station provides the ring timing reference by timing its output from a fixed frequency reference while the other stations derive their output timing from their received data (recovered clock). The elastic buffer allows the station supplying the ring timing reference (crystal transmit) to compensate for dynamic variations in the cumulative ring latency.

### 5.1.2 MAC interface service specification

The following service primitives specify the required information that is passed between the MAC and the PSC. The PSC/MAC service specification is solely for the purpose of explaining token ring operation and does not imply any particular implementation.

#### 5.1.2.1 PS\_UNITDATA.indication

This primitive defines the transfer of data from the PSC to the MAC.

PS\_UNITDATA.indication[ Rcv\_symbol (5.6) ]

The Rcv\_symbol specified is one of the following:

Data\_zero  
Data\_one  
Non-data\_J  
Non-data\_K

**When generated.** The PSC generates a PS\_UNITDATA.indication for each symbol received.

**Effect of receipt.** The MAC uses this information to process frames and tokens.

#### 5.1.2.2 PS\_UNITDATA.request

This primitive defines the transfer of data from the MAC to the PSC.

PS\_UNITDATA.request [ Tx\_symbol (5.5) ]

The Tx\_symbol specified is one of the following:

Data\_zero  
Data\_one  
Non-data\_J  
Non-data\_K

**When generated.** The MAC generates a PS\_UNITDATA.request for each symbol of a token or frame originated by the station and for each symbol to be modified in the repeated data.

**Effect of receipt.** The PSC uses this information to generate the transmitted signal.

**5.1.2.3 PS\_STATUS.indication**

This primitive is used by the PSC to inform the MAC of errors and significant status changes.

PS\_STATUS.indication [Frequency\_error (5.7.2),  
Medium\_rate\_error (5.2),  
Starting\_delimiter (5.6),  
Ending\_delimiter (5.6),  
ED\_alignment\_error (5.6),  
Burst4\_error (5.4.2),  
Burst5\_error (5.4.2)]

**When generated.** Upon detection of any of the conditions, the PSC generates a PS\_STATUS.indication.

**Effect of receipt.** These signals are processed by the MAC protocol.

**5.1.2.4 PS\_CONTROL.request**

This primitive is used by the MAC to request certain actions of the PSC.

PS\_CONTROL.request [Crystal\_transmit (5.8),  
Medium\_rate (5.2),  
Repeat\_mode (5.4.1) ]

Crystal\_transmit is specified as one of the following:

Asserted  
Not asserted

Medium\_rate is specified as one of the following:

4 Mbit/s  
16 Mbit/s

Repeat\_mode specified is one of the following:

Repeat  
Fill

**When generated.** The MAC generates a PS\_CONTROL.request for each action request.

**Effect of receipt.** The PSC performs the appropriate action.

**5.1.2.5 PS\_EVENT.response**

This primitive is used by the MAC to indicate certain events to the PSC.

PS\_EVENT.response [ Token\_received (5.8.3.1) ]

**When generated.** The MAC generates a PS\_EVENT.response for each event detected.

**Effect of receipt.** The PSC takes appropriate action (i.e., initializes the elastic buffer).

### 5.1.3 PMC interface service specification

The following service primitives specify the required information that is passed between the PSC and the PMC. The PSC/PMC service specification is solely for the purpose of explaining token ring operation and does not imply any particular implementation.

#### 5.1.3.1 PM\_UNITDATA.indication

This primitive defines the transfer of data from the PMC to the PSC.

PM\_UNITDATA.indication [ Rcv\_signal\_element (5.6) ]

The Rcv\_signal\_element specified is one of the following:

Logic\_0  
Logic\_1

**When generated.** The PHY generates a PM\_UNITDATA.indication for each signal element received.

**Effect of receipt.** The PSC processes this information for providing data to the MAC, detecting frame delimiters, and detecting signaling errors.

#### 5.1.3.2 PM\_UNITDATA.request

This primitive defines the transfer of data from the PSC to the PMC.

PM\_UNITDATA.request [ Tx\_signal\_element (5.5) ]

The Tx\_signal\_element specified is one of the following:

Logic\_0  
Logic\_1

**When generated.** The PSC generates a PM\_UNITDATA.request every signal element interval.

**Effect of receipt.** The PMC uses this information to generate the transmitted signal.

### 5.1.4 MAC/PMC interface service specification

The following service primitives specify the information that is passed between the MAC and the PMC. The MAC/PMC service specification is solely for the purpose of explaining token ring operation and does not imply any particular implementation.

#### 5.1.4.1 PM\_STATUS.indication

This primitive is used by the PMC to inform the MAC of errors and significant status changes.

PM\_STATUS.indication [ Signal\_detection (5.7.1),  
Wire\_fault (5.9) ]

Signal detection is specified as one of the following:

Signal\_acquired  
Signal\_loss

Wire\_fault is specified as one of the following:

Detected  
Not\_detected

**When generated.** Upon detection of any of the conditions, the PMC generates a PM\_STATUS.indication.

**Effect of receipt.** These signals are processed by the MAC protocol.

#### 5.1.4.2 PM\_CONTROL.request

This primitive is used by the MAC to request certain actions of the PSC.

PM\_CONTROL.request [Insert\_station (5.9),  
Remove\_station (5.9),  
Medium\_rate (5.2) ]

Medium\_rate is specified as one of the following:

4 Mbit/s  
16 Mbit/s

**When generated.** The MAC generates a PM\_CONTROL.request for each action request.

**Effect of receipt.** The PHY performs the appropriate action.

## 5.2 Data signaling rate

A station shall be capable of transmitting and receiving symbols at one or both of the following nominal bit rates:

- a) 4 Mbit/s
- b) 16 Mbit/s

One symbol (two signal elements) shall be output per bit period.

The MAC request Medium\_rate is used to select the data rate for stations supporting both data rates. The signal Medium\_rate\_error is optionally provided to indicate to the MAC that the station has detected the ring is operating at a different rate than the rate requested by Medium\_rate. The mechanism to determine the ring media rate is not specified nor required by this standard. When the Medium\_rate\_error function is implemented in a station, certain ring conditions, such as circulating burst4 data patterns, may create an incorrect frequency determination that falsely set this error flag. The MAC protocol specifies the actions taken (i.e., if Medium\_rate\_error is detected during the join process, the station removes from the ring).

The source of a station's transmitter timing is selected by the MAC request Crystal\_transmit. All stations shall transmit signal elements timed from one of the following two sources based on the Crystal\_transmit request from the MAC:

- a) A stable timing reference (hereafter referred to as crystal clock) with a frequency tolerance of  $\pm 0.01\%$  when the MAC asserts Crystal\_transmit.

- b) A clock recovery circuit that extracts timing information inherent in the transitions from the received data signals when the MAC is not asserting `Crystal_transmit`. The clock recovery circuit tracks the frequency and phase of the received data stream as specified in 7.2.3.

Under normal ring conditions, the token ring protocol places one station, called the active monitor, in the state where it derives its transmit timing from the local crystal clock. The remainder of the stations transmit symbols using the timing information recovered from the received signal. This protocol results in all the other stations transmitting data at the same long-term time-averaged rate as the received signal. However, the instantaneous rate of the data signal at each station does not remain constant due to jitter from various sources. Because the received data signal timing information is used to reclock the station's transmitted data, jitter accumulates in the ring starting at the active monitor. The jitter accumulation continues around the ring until it reaches the active monitor. Jitter does not propagate through the active monitor since its data transmission is timed from its crystal clock. An elastic buffer is used in the active monitor station to absorb the jitter accumulation and avoid adding or removing signal elements from the repeated data stream.

### 5.3 Symbol coding (differential Manchester 1, 0, J, K)

Symbols shall be output to the medium in the form of differential Manchester code which is characterized by the transmission of two signal elements per symbol as shown in Figure 27. Symbols are output at the data bit rate of 4 or 16 Mbit/s as described in 5.2.

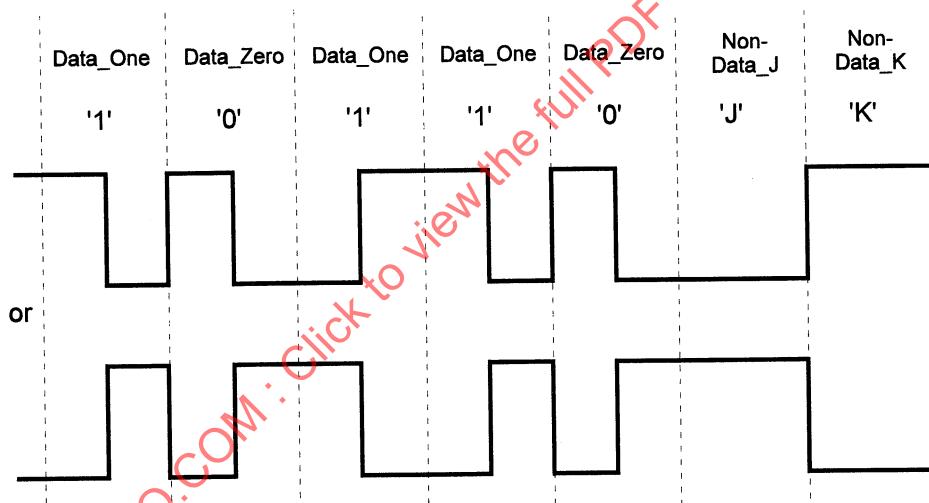

Figure 27—Example of symbol encoding

In the case of two symbols, `Data_one` and `Data_zero`, a signal element of one polarity is output for one half the duration of the symbol being transmitted, followed by the contiguous output of a signal element of the opposite polarity for the remainder of the symbol duration. This coding scheme provides the following distinct advantages:

- a) The resulting signal has no DC component and can readily be inductively or capacitively coupled.
- b) The forced mid-symbol transition conveys inherent timing information on the channel.
- c) The signals are independent of channel polarity reversals.

The value of the four differential Manchester symbols depends on the polarity of the trailing signal element of the preceding symbol. The symbol values have the following characteristics.

- a) **Data\_zero** symbol: The polarity of the leading signal element is the opposite polarity to the trailing signal element of the preceding symbol. Consequently, a transition occurs at the symbol boundary as well as at mid-symbol.
- b) **Data\_one** symbol: The polarity of the leading signal element is the same polarity as the trailing signal element of the preceding symbol. Consequently, only one transition occurs (at mid-symbol).
- c) **Non-data\_J** symbol: Both signal elements are the same polarity and they are the same polarity as the trailing signal element of the preceding symbol.
- d) **Non-data\_K** symbol: Both signal elements are the same polarity and they are the opposite polarity to the trailing signal element of the preceding symbol.

Although the **Non-data\_J** and **Non-data\_K** symbols are not true differential Manchester symbols (no mid-symbol transition), they are referred to as differential Manchester symbols. The **Non-data\_J** and **Non-data\_K** symbols are used by the starting and ending delimiters (specified in 3.2.1 and 3.2.8) to define the beginning and end of tokens and frames. Since the transmission of single **Non-data\_J** or **Non-data\_K** symbols introduces a DC component on the ring, they are normally transmitted as a pair of J-K symbols to minimize the accumulation of a DC signal component (the combination of a **Non-data\_J** followed immediately by a **Non-data\_K** has no DC component).

## 5.4 Repeat path

### 5.4.1 Repeat/fill

When the value for **Repeat\_mode** indicated by the MAC is "repeat," the station shall repeat the received data such that each received transition (reversal of signal element polarity from one signal element to the next) results in a corresponding transition in the transmitted data.

When the value for **Repeat\_mode** indicated by the MAC is "fill," that station shall source any combination of **Data\_zero** and **Data\_one** symbols (**Data\_zero** symbols preferred) and not repeat the received data.

### 5.4.2 Burst error detection, correction, and indication

The PSC indicates a **Burst4\_error** to the MAC when it detects four signal elements with the same polarity in succession. The PSC indicates a **Burst5\_error** to the MAC when it detects five or more signal elements with the same polarity in succession, and, if the station is repeating, the station shall introduce a change of polarity (that is, a transition) for every transmitted signal element starting at the end of the fourth signal element in the sequence until a transition is received from the ring, at which time the station returns to repeating. This process shall assure that no more than 4 signal elements with the same polarity are ever repeated by the station. Note that when a **Burst5\_error** condition is detected, the PSC indicates a **Burst4\_error** and one signal element later indicates a **Burst5\_error**.

## 5.5 Symbol encoder

The symbol encoder allows the MAC to modify individual symbols in the repeated frames and tokens as well as generate frames and tokens.

The symbol encoder shall encode for transmission, the symbols presented to it by the MAC (**Tx\_symbol**). The values for the symbols exchanged between MAC and symbol encoder are shown as follows. (Specific implementations are not constrained in the method of making this information available.)

Data\_zero  
Data\_one  
Non-data\_J  
Non-data\_K

## 5.6 Symbol decoder

Received symbols (Rcv\_symbol) shall be decoded using an algorithm that is the inverse of the one described for symbol encoding. The station shall monitor the received data for the signal element pattern corresponding to a starting delimiter and ending delimiter as shown in figure 28.

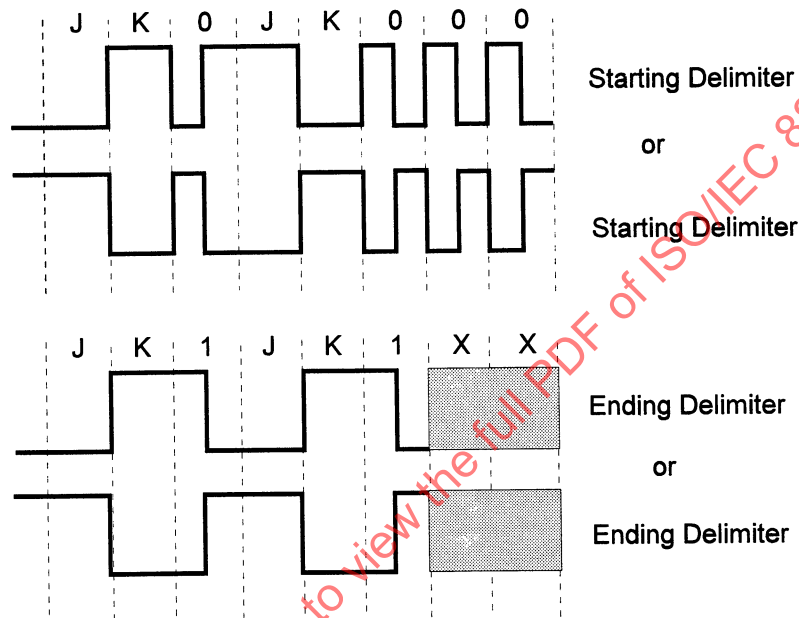

Figure 28—Starting and ending delimiter patterns

Starting delimiters (SD) and ending delimiters (ED) shall be detected even if they do not occur on a symbol boundary. If an ending delimiter is detected that does not occur on the symbol boundary established by the previous SD, then an ED\_alignment\_error is indicated to the MAC (the MAC uses this signal to verify that the ending delimiter falls exactly on an octet boundary). Once a delimiter has been detected, it shall establish the symbol and octet boundary for the decoding of the received signal elements until another delimiter is detected.

## 5.7 Signal acquisition/loss and timing synchronization

### 5.7.1 Signal acquisition/loss

When the signal at the receiver input meets the requirements for amplitude, frequency, jitter, etc., as specified in clause 7, the receiver's clock recovery circuit shall synchronize with the received signal such that no signal elements are added or dropped from the repeated data. The station indicates signal acquisition to the MAC interface as follows:

- a) The station shall, upon receipt of a signal that is within specification, acquire phase synchronization within 1.5 ms and indicate Signal\_acquired to the MAC.

- b) The PHY should indicate Signal\_loss to the MAC interface when the receiver is not able to provide accurate data due to lack of input signal quality including loss of timing synchronization.

### 5.7.2 Frequency error

A difference in frequency between the received data and the crystal clock may cause an overflow or underflow of the elastic buffer. This overflow or underflow is optionally indicated as Frequency\_error to the MAC as follows: 1) When operating in the Crystal\_transmit mode as described in 5.8.3 or 2) when not in the Crystal\_transmit mode, by monitoring the rate at which the elastic buffer (which is not in the data path) underflows or overflows. If this or another method is used to detect frequency error, Frequency\_error shall not be indicated if

- a) The input jitter is below the value B specified in 5.8.3, and
- b) The frequency error over 1 ms is less than 1.76% at 16 Mbit/s or 0.7% at 4 Mbit/s.

Frequency\_error, if implemented, shall be indicated if the received bit rate, averaged over 32 ms, deviates more than  $\pm 10\%$  from the data signaling rate specified in 5.2.

## 5.8 Latency

Latency is the time, expressed in number of symbols, it takes for a signal element to pass through a ring component. This clause specifies two latency buffers, a fixed latency buffer and an elastic buffer, that are inserted in the ring signal path as requested by the MAC protocol. To ensure stations do not introduce excessive latency, it is recommended that the average PHY latency should not exceed 6.25 ms to prevent expiration of TRR (3.4.2.13). It is further recommended that this time should not exceed 2.5 ms for performance/access reasons.

### 5.8.1 Ring latency

Ring latency, defined as the time it takes for a signal element to travel around the entire ring, is equal to the cumulative latency of the ring plus the latency of the active monitor. Cumulative latency is the time it takes for a signal element to travel from the active monitor's transmitter output to its receiver input. The latency of the active monitor consists of two buffers, elastic buffer and fixed latency buffer, in addition to the normal station latency. The active monitor station uses the elastic buffer to compensate for variations in cumulative latency and uses the fixed latency buffer to provide the required latency to ensure ring operation even when only one station is on the ring.

When the ring is in a normal operating state, the MAC protocol ensures that only one station, the active monitor, will have Crystal\_transmit asserted, which inserts the fixed latency and elastic latency buffers in the ring path. The active monitor transmits data to the ring timed from its local clock, which provides the master timing for the ring. Although the mean data signaling rate around the ring is established by the active monitor, segments of the ring can, for short periods of time, operate at a slightly higher or lower signaling rate than the signaling rate of the active monitor. The cumulative effect of these signaling rate variations may cause variations in the cumulative latency.

The elastic buffer in the active monitor compensates for the variation in the cumulative latency as follows. When the frequency of the received signal at the active monitor is slightly faster than the crystal clock, the elastic buffer will expand, as required, to maintain a constant ring latency. Conversely, if the frequency of the received signal is slightly slower, the elastic buffer will contract to maintain a constant ring latency. Constant ring latency is a requirement to avoid adding or dropping signal elements from the data stream. The elastic buffer compensates for dynamic variations in latency due to jitter. The elastic buffer does not compensate for some changes such as step changes in latency caused by stations becoming or ceasing to be stacking stations.

The fixed latency buffer is provided by the active monitor to provide the latency required for token circulation as described in 5.8.2.

### 5.8.2 Fixed latency buffer

In order for the token to continuously circulate around the ring, the ring must have a minimum ring latency of at least 24 symbols (the number of symbols in a token). To ensure this minimum ring latency, a fixed latency buffer of at least 24 symbols shall be inserted into the data path of the station when MAC asserts `Crystal_transmit`.

### 5.8.3 Elastic buffer

An elastic buffer shall be present in the station's data path when the MAC asserts `Crystal_transmit`. This elastic buffer latency is in addition to the latency provided by the fixed latency buffer.

#### 5.8.3.1 Operation of the elastic buffer

Cumulative latency variations are based on the jitter considerations discussed in annex C. The elastic buffer shall accommodate without error a minimum cumulative latency variation of positive or negative  $B$  symbols where

Data rate	=	4	16	Mbit/s
$B$	=	3	15	symbols

The elastic buffer in the active monitor shall be initialized to the center of the elastic latency range as described in 5.8.3.2.

The active monitor's elastic buffer shall also be reinitialized to the center of the elastic latency range as described in 5.8.3.2 whenever the MAC indicates `Token_received` (station is repeating a token).

If the elastic buffer exceeds full elasticity (underflow/overflow), it shall be reinitialized as described in 5.8.3.2. In addition, the signal `Frequency_error` may optionally be indicated as described in 5.7.

#### 5.8.3.2 Centering of the elastic buffer

The length of the elastic buffer is initialized (reinitialized) to at least the minimum allowable elastic latency ( $B$  symbols) and no more than the actual total elastic latency minus the minimum allowable elastic latency (i.e., with a maximum elastic buffer size  $x$  then after centering, the latency will be a minimum of  $B$  and a maximum of  $x-B$ ). After the elastic buffer is centered, the station shall accommodate without error a minimum cumulative latency variation of positive or negative  $B$  symbols as specified in 5.8.3.1.

The centering process may cause signal elements to be added or removed from the repeated data stream. In addition, the reinitializing of the elastic buffer may cause an inversion of the repeated data produced by the adding or removing of an odd number of signal elements. The total combined effect of reinitializing the elastic buffer shall not introduce more than a single isolated `Non-data_J` or `Non-data_K` symbol into the data stream. This symbol shall not immediately precede a starting delimiter. During re-initialization, no portion of the token shall be altered. The active monitor station may alter signal elements following the token (recommended) or signal elements preceding the token (i.e., the interframe gap).

#### 5.8.3.3 Modification of the interframe gap

Although the centering process may cause signal elements to be added or removed from the interframe gap, the length of the interframe gap has been specified to permit the centering of the active monitor's elastic buffer with an elastic buffer length of  $2B$  symbols as specified in 5.8.3.1. When the interframe gap

is equal to or larger than the length specified in 3.2.10, the active monitor station reinitializing its elastic buffer shall only alter those symbols within the interframe gap or the fill following the token. Except for the active monitor, a station shall not cause the interframe gap to be decreased to less than the minimum specified in 3.2.10. When the interframe gap is equal to or larger than the length specified in 3.2.10 and the cumulative latency variation is equal to or less than  $B$  symbols specified in 5.8.3.1, then the active monitor station shall not reduce the length of the interframe gap to less than  $C$  symbols as specified:

Data rate	=	4	16	Mbit/s
$C$	=	5	25	symbols

If the active monitor station alters an interframe gap, it shall only alter the interframe gap preceding a token and may alter all of the signal elements in the interframe gap provided that the altered signal elements result in only Data\_zero and Data\_one symbols.

A station is not required to receive a frame preceded by an interframe gap with a length less than 8 symbols at 4 Mbits/s or 24 symbols at 16 Mbits/s.

### 5.9 Ring access control

The Ring access control (RAC) receives two signals from the MAC to control the physical insertion of the station into the ring. As defined in 7.2.1.1, when the MAC indicates Insert\_station, the RAC signals “ring insertion” to the concentrator’s TCU. Normally, this action will attach the upstream station’s transmitter output to this station’s receiver input and also attach this station’s transmitter output to the downstream station’s receiver input. Conversely, when the MAC indicates Remove\_station, the station’s RAC signals “ring bypass” to the TCU. The TCU is expected to connect the upstream station’s transmitter output to the downstream station’s receiver input. The station’s transmitter output will also be connected to the station’s receiver input utilizing as much of the physical medium as possible from the station to the TCU and still isolate the station from the ring. This “wrapping” of the station’s output to its input allows the station to perform a comprehensive self test verifying as much of the lobe data path and station’s components as possible.

The Wire\_fault attribute is provided by the PMC to indicate to the MAC that the station has or has not detected a wire fault condition specified in 7.2.1.2. This signal generally indicates whether the station is or is not properly connected to the TCU. Detection of Wire\_fault by the PMC varies with the medium used to attach the station to the ring. The MAC protocol specifies the actions taken (i.e., if Wire\_fault is detected, the station eventually removes from the ring as specified in table 7).

## 6. Token ring management

This clause specifies the primitives necessary to manage operation of a token ring station. This clause also defines the managed objects specific to a token ring station.

### 6.1 Station management primitives

This clause specifies the primitives necessary to manage the operation of the MAC and PHY as a station and also to support additional management functions. Specification of these primitives do not specify any particular implementation but rather are supplied solely to define the management of the MAC and PHY entities.

The support of the parameters, events, and actions accessible through the primitives is necessary only to support management applications. The only required primitives are the MGT\_ACTION.request(acOpen) and the MGT\_ACTION.request(acClose). The remaining primitives and their attributes are defined for interoperability with other standards and thus are only required as specified by other applications.

#### 6.1.1 Token ring actions

```
MGT_ACTION.request { action  
                    parameters }
```

```
MGT_ACTION.response { action  
                    status }
```

The action may be acOpen or acClose, which are defined as follows:

- **acOpen:** Management instructs the MAC to join the station to the ring. This action issues the Connect.MAC event to the MAC protocol. Upon completion (success or failure) of the join ring process, an Open\_status is returned to the MGT interface. The parameters passed with this action are the individual MAC address (IndMACAddress) and the ring rate (RingRate). If the MAC address is not specified, then the MAC protocol will use the MAC address assigned by the manufacturer (a universally administered). The MAC address parameter provides the means for management to set a locally administered address. If the specified address (1) is not an individual locally administered address or (2) if it is not specified and no universally administered address is assigned, then the status returned in the MGT\_ACTION.response is Invalid\_address. If the requested data rate is not supported, then the status returned is Rate\_not\_supported.

The MGT\_ACTION.response is generated when the station has successfully joined the ring or when the join process has failed. The returned status is defined as follows:

**Table 8—MGT\_ACTION.response definition**

Open status	Table 7 REF	Definition
sNotOperational	n/a	Rejected—device not ready, internal error, failure, etc.
sInvalidAddress	n/a	Rejected—MAC address is invalid (group or not specified)
sRateNotSupported	n/a	Rejected—the requested data rate is not supported
sSuccess	100, 131, 188	Successful
sFailGeneral	n/a	Failure in activation—general
sFailLobeTest	276	Failure in activation—lobe test failure
sFailDataRate	238	Failure in activation—medium rate error
sFailDuplicate	127	Failure in activation—duplicate address
sFailDATTimeout	282	Failure in activation—DAT time-out—TJR expired
sFailNNTIMEout	284	Failure in activation—neighbor notification time-out
sFailInitTimeout	286, 317	Failure in activation—initialization time-out
sFailRingBeaconing	067, 068, 069, 070, 071	Failure in activation—beacon received
sFailPurgeTimeout	318, 319, 320, 321	Failure in activation—purge failure—TRP expired
sFailClaimTimeout	265, 269, 270	Failure in activation—claim failure—TCT expired
sFailBeaconTimeout	263	Failure in activation—beacon failure—TBT expired
sFailSignalLoss	209, 210, 211	Failure in activation—signal loss
sFailInternal	224, 225, 226, 228, 229	Failure in activation—internal error
sFailTxFault	255, 256, 258, 259	Failure in activation—station transmit failure
sRemove	156, 157, 158, 160, 161	Failure in activation—remove frame received

- **acClose:** Management instructs the MAC protocol to remove the station from the ring. There are no parameters associated with this action. This action issues the Disconnect.MAC event to the MAC protocol. When the station has completed removing from the ring (i.e., transitions to bypass (JS=BP) as per table 7 REF 325), the MGT\_ACTION.response is indicated with the status of Complete.

### 6.1.2 Token ring events

**MGT\_EVENT.indication** { event,  
event\_status }

An event report is an information unit that is used to inform MGT of a significant activity in the operation of the resource. A description of the events defined for token ring follows the list of events:

evRingNonOperational  
evRingOperational  
evRingBeaconing  
evStationFailure  
evProtocolError

**6.1.2.1** The **evRingNonOperational** event is generated when the monitor FSM transitions into recovery (MS=TCT, RCT, TBN, RBN). The Event\_status is defined as follows:

**Table 9—evRingNonOperational Event\_status**

Event_status	Table 7 REF	Definition
sRingNonOp	n/a	Ring not operational—cause not specified
sPurgeFailure	322	Claim—purge failure
sRingClaiming	108, 115, 116, 117, 118	Claim—claim received
sClaimNoMonitor	026, 310, 336, 337,	Claim—no active monitor (TJR, TNT, TSM=E)
sClaimSignalLoss	214, 215	Claim—signal loss
sRingBeaconing	075, 078	Beacon received

**6.1.2.2** The **evRingOperational** event is generated when the ring transitions into normal repeat (MS=RPT) as per table 7 REF 169, 175, 177. The Event Status is defined as follows:

**Table 10—evRingOperational Event\_status**

Status	Table 7 REF	Definition
sRingNonOp	175, 177, 169	Ring operational—monitor state not specified
sStandbyMonitor	175, 169	This station is a standby monitor (FAM=0)
sActiveMonitor	177	This station is the active monitor (FAM=1)

**6.1.2.3** The **evRingBeaconing** event is generated when the monitor FSM transitions into a beacon state (MS=TBN, RBN) as per table 7 REF 076, 078, 073, 075, 273, 271, 272, 266. The Event\_status is defined as the SA, beacon type, reported UNA, and reported physical drop number from the received beacon frame if MS=RBN or the transmitted beacon frame if MS=TBN.

**6.1.2.4** The **evStationFailure** event is generated when a station fault causes the station to be removed from the ring. The Event\_status is defined as follows:

**Table 11—evStationFailure Event\_status**

Status	Table 7 REF	Definition
sRingNonOp	n/a	Station removed—cause not specified
sRemove	161	Remove frame received
sWireFault	345	Wire fault
sFailInternal	227, 257	Internal failure
sFailTest	278	Beacon test failure

**6.1.2.5** The **evProtocolError** event is generated when the MAC protocol detects an error. The event status is defined as either sActiveMonitorError or sNotificationIncomplete.

**Table 12—evProtocolError Event\_status**

Status	Table 7 REF	Definition
sActiveMonitorError	061, 104, 171, 322	Active monitor error
sNotificationIncomplete	260	Neighbor notification incomplete

The status for the active monitor error includes the error code (EC) and the status for the notification incomplete includes the address of the last station to participate (LMP).

### 6.1.3 Attributes

**MGT\_GET.request** { attributeID }

**MGT\_REPLACE.request** { attributeID,  
newValue }

**MGT\_GET.request:** The MGT\_GET is issued to request information (attributes) about the token ring station. The effect of the request is that the requested attribute is returned. There is only one parameter associated with the Get request and it indicates the attributes group to be supplied in the response.

**MGT\_REPLACE.request:** The MGT\_REPLACE is issued to change certain characteristics (attributes) that effect the operation of the token ring station. The parameters indicate the attribute to change and the desired value of the attribute. The effect of the request is that the attribute is modified and a response is generated containing the value of the attribute after modification. Note that some values of attributes listed as GET-REPLACE may not be supported by the station and therefore may not change.

The attributes of a resource indicate its state (present or past) and control its operation (in the future). The Token Ring station attributes are specified in groups. Attributes are classified as follows:

- a) *Characteristics.* Operational information that describes some aspect of the resource's capabilities. In general, characteristics affect the operation of the resource at some future time. Characteristics may be specifically defined to be GET (read-only) or GET-REPLACE (read-write) with respect to remote management access.
- b) *Status.* Dynamic information about the resource's present state. Status attributes are read-only.
- c) *Statistics.* Information about the resource's past behavior. Statistical attributes are typically a form of an event log, such as counters. The only type of statistics defined for this standard are counters that are read-only with no reset control.

#### 6.1.3.1 Characteristics

Characteristics are the reference data of a resource that may be either necessary or useful to operate or manage the resource.

##### 6.1.3.1.1 Station characteristics

These attributes specify the operating characteristics of the station in general. This group represents attributes that are characteristic of network operation and some of these parameters may optionally be set by management while others can not be altered by management. The characteristics of the station are

**IndMACAddress**—This parameter specifies the address used in the SA field of the MAC frames originated by this station. This attribute may only be set by the Open command and thus cannot be changed while the MAC is active.

- UniversallyAdministeredAddress**—This parameter specifies the universally administered address (if any) assigned to this station. This value can not be set by management.
- FunctionalAddresses**—This specifies the set of functional addresses active in the station (i.e., MAC will set the A bits and copy the frame). This parameter provides the means for management to activate functional addresses.
- GroupAddresses**—This parameter specifies a list of group addresses recognized by the station (i.e., MAC will set the A bits and copy the frame). This parameter provides the means for management to establish group addresses.
- MicrocodeLevel**—This parameter specifies the value of the X'23' Ring Station Version Number subvector (3.3.4) used in the Report Station State MAC frame. This value can not be set by management.
- ProductInstanceId**—This parameter specifies the value of the X'22' Product Instance ID subvector (3.3.4) used in the Report Station Attachment and Report New Active Monitor MAC frames. This value can not be set by management.
- MaxFrameSize**—The value of this parameter specifies the size, in octets, of the largest frame that may be transmitted and received by the station.

#### 6.1.3.1.2 Protocol configuration options

These attributes specify the operating characteristics of the MAC protocol (refer to clause 3.5). This group represents attributes that may optionally be set by management.

- Burst4Option**—This parameter specifies the value of the flag FBEO indicating whether the station compensates for burst4 errors when stripping frames. The value is either Compensates or No\_compensation.
- BeaconHandling**—This parameter specifies the value of the flag FBHO indicating whether the station waits until JS=JC before fully participating ring recovery. The value is either Before\_initialization or After\_initialization
- ClaimContender**—This parameter specifies the value of the flag FCCO indicating whether the station always actively participates in the claiming process. The value is either Contender or No\_contender.
- EarlyTokenRelease**—This parameter specifies the value of the flag FETO indicating if early token release is selected. The value is either Enabled or Not\_enabled.
- RingRate**—This parameter specifies the value of the station's operating speed use to set the flag FMRO. The value is either 4\_Mbit/s or 16\_Mbit/s. This attribute may only be set by the Open command and thus cannot be changed while the MAC is active.
- MultipleFrameTransmission**—This parameter specifies the value of the flag FMFTO indicating whether the station honors the reservation field when transmitting multiple frames. The value is either Relinquish or Continue.
- RejectRemove**—This parameter specifies the value of the FRRO indicating whether the station will honor the Remove MAC frame. The value is either Removes or Rejects.
- TokenErrorDetection**—This parameter specifies the value of the FTED indicating whether the station counts errors in Tokens. The value is either Counted or Not\_Counted
- TokenHandling**—This parameter specifies the value of the FTTHO indicating how the station detects lost tokens. The value is either Active\_timer or Periodic\_inspection.
- ErrorCountingMethod**—This parameter specifies the value of the FECO indicating how the station manages the error report timer. The value is either Triggered or Free\_running.

#### 6.1.3.2 Status

A status attribute is one that indicates something about the current state of the resource. A status attribute is distinguished from a characteristic in that it is modified internally by the resource rather than by an external management entity. Status attributes are read-only.

### 6.1.3.2.1 Station operating status

**NAUN**—This parameter specifies the MAC address and physical drop number of this station's nearest upstream neighbor. The parameter values are derived from the AMP or SMP frame (table 7 REF 064, 199, 200).

**RingNumber**—This parameter specifies the value set by the X'03' Local Ring Number subvector (3.3.4) from the Change Parameters or Initialize Station MAC frame.

**AccessPriority**—This parameter specifies the value set by the X'07' Authorize Access Priority subvector (3.3.4) from the Change Parameters MAC frame.

**ErrorReportTimer**—This parameter specifies the value of the timer TER as set by the X'05' Error Timer Value subvector (3.3.4) from the Change Parameters or the Initialize Station MAC frame.

**AuthorizeFunctionClasses**—This parameter specifies the value set by the X'06' Authorize Function Classes subvector (3.3.4) of the Change Parameters MAC frame.

**PhysicalDropNumber**—This parameter specifies the value set by the X'04' Assign Physical Drop Number subvector (3.3.4) of the Change Parameters or the Initialize Station MAC frame.

**RingStationStatus**—This parameter specifies the value of the X'29' Ring Station Status subvector (3.3.4) used in the Report Station State MAC frame.

### 6.1.3.2.2 MAC Protocol Status

**JoinState**—This parameter specifies the present state of the Join FSM. The value will be one of the following: NotSpecified, Bypass, LobeTest, DetectMonitorPresent, AwaitNewMonitor, DuplicateAddressTest, NeighborNotification, RequestInitialization, JoinComplete, or BypassWait.

**MonitorState**—This parameter specifies the present state of the Monitor FSM. The value will be one of the following: NotSpecified, StandbyMonitor (MS=RPT & FAM=0), ActiveMonitor (MS=RPT & FAM=1), RingPurge (MS=TRP), ClaimTransmit (MS=TCT), ClaimRepeat (MS=RCT), BeaconTransmit (MS=TBN), BeaconRepeat (MS=RBN), or BeaconTest (MS=BNT).

**BeaconInfo**—These parameters specify the MAC address of the beaconing station, the beacon type, the MAC address of the beaconing station's upstream neighbor, and the physical drop number of the beaconing station. These parameters are the value of the SA, the X'01' Beacon Type subvector, the X'02' UNA subvector, and the X'0B' Physical Drop Number subvector in the last Beacon MAC frame transmitted or received.

**TxBeaconType**—This parameter specifies the value of the X'01' Beacon Type subvector in the last Beacon MAC frame transmitted.

### 6.1.3.3 Statistics

Statistics are attributes that contain a record of events over some period of time. The statistics defined for this standard are counters with no reset control. Access to the counterValue parameter is read-only. Refer to 3.6 for definition of each of the error counters.

#### 6.1.3.3.1 Isolating error counters group

The isolating error counters group lists the counters and their definitions. These errors are those that can be isolated to a particular fault domain (this station, its upstream neighbor, and the wire between them). The following indicates the parameters reported and the FSM transition that causes the counter to increment:

**LineErrorCounter**—This counter is incremented each time CLE is incremented (table 7 REF 204, 205, 308, 309).

**BurstErrorCounter**—This counter is incremented each time CBE is incremented (table 7 REF 001, 002).

**AcErrorCounter**—This counter is incremented each time CACE is incremented (table 7 REF 194, 195, 196, 197).

**AbortErrorCounter**—This counter is incremented each time CABA is incremented (table 7 REF 252, 253, 302, 303).

**InternalErrorCounter**—This counter is incremented each time CIE is incremented (table 7 REF 222, 223).

### 6.1.3.3.2 Non-isolating error counters group

The non-isolating error counters group lists the counters and their definitions. These errors are those that cannot be isolated to a particular fault domain. The following indicates the parameters reported and the FSM transition that causes the counter to increment:

**LostFrameErrorCounter**—This counter is incremented each time CLFE is incremented (table 7 REF 031, 032).

**ReceiveCongestionErrorCounter**—This counter is incremented each time CRCE is incremented (table 7 REF 152, 153).

**FrameCopiedErrorCounter**—This counter is incremented each time CFCE is incremented (table 7 REF 041, 042).

**FrequencyErrorCounter**—This counter is incremented each time CFE is incremented (table 7 REF 147, 148)

**TokenErrorCounter**—This counter is incremented each time CTE is incremented (table 7 REF 052, 053, 291, 292, 339, 340, 342, 343).

## 6.2 Token ring station managed objects

This clause contains the managed objects for the token ring station. These managed objects are specified in conformance with ISO 10742 : 1994. The service and protocol elements that are involved in the management of token ring stations are defined in ISO/IEC 15802-2 : 1995.

A managed object is defined as the smallest accessible entity that contains managed attributes, actions, and event notifications that are independent and unrelated to duplicate copies of the same attributes, actions, and event notifications that exist in another managed entity.

The MAC sublayer is defined by the TokenRingLayer2MAC managed object.

### 6.2.1 TokenRingLayer2MAC MANAGED OBJECT CLASS

oTokenRingLayer2MAC MANAGED OBJECT CLASS

DERIVED FROM “10165-2 : 1992”:top;mACDLE;  
CHARACTERIZED BY

pTokenRingMAC;

CONDITIONAL PACKAGES

pTrStationCharacteristics PRESENT IF supported,

pTokenRingMACOptions PRESENT IF supported,

pTrCharacteristics PRESENT IF supported,

pTokenRingStatus PRESENT IF supported,

pTokenRingStatistics PRESENT IF supported;

REGISTERED AS {iso(1) member-body(2) us(840) 802dot5(10033) managedobjectclass(3) token-ringlayer2mac(0)};

**6.2.2 TokenRingLayer2MAC NAME BINDING**

nTokenRingLayer2MAC NAME BINDING  
 SUBORDINATE OBJECT CLASS TokenRingLayer2MAC;  
 NAMED BY  
 SUPERIOR OBJECT CLASS macDLE;  
 WITH ATTRIBUTE ID UniversallyAdministratedAddress  
 REGISTERED AS {iso(1) member-body(2) us(840) 802dot5(10033) namebinding(6)  
 tokenringlayer(0)};

**6.2.3 TokenRingLayer2MAC PACKAGES**

**6.2.3.1 TokenRingMAC PACKAGE**

pTokenRingMAC PACKAGE  
 BEHAVIOR bTokenRingLayer2MAC BEHAVIOR  
 DEFINED AS !This package identifies the various MAC addresses related to the station and provides  
 the general management operation.!.  
 ATTRIBUTES

aIndMACAddress	GET,	-- 0
aUniversalAddress	GET,	-- 1
aFunctionalAddresses	GET-REPLACE,	-- 6
aGroupAddresses	GET-REPLACE,	-- 7
aNAUN	GET;	-- 22

ATTRIBUTE GROUPS

"gTrStationAddresses"		-- 0
-----------------------	--	------

ACTIONS

acOpen,		-- 0
acClose,		-- 1

NOTIFICATIONS

evStationFailure;		-- 3
-------------------	--	------

REGISTERED AS {iso(1) memberbody(2) us(840) 802dot5(10033) package(4)  
 tokenringmac(0)};

**6.2.3.2 TrStationCharacteristics PACKAGE**

pTrStationCharacteristics PACKAGE  
 BEHAVIOR bTokenRingLayer2MAC BEHAVIOR  
 DEFINED AS !This package identifies the characteristics of the ring station.!.  
 ATTRIBUTES

aMicrocodeLevel	GET,	-- 2
aProductInstanceId	GET,	-- 3
aMaxFrameSize	GET;	-- 4

ATTRIBUTE GROUPS

"gTrStationCharacteristics"		-- 1
-----------------------------	--	------

REGISTERED AS {iso(1) memberbody(2) us(840) 802dot5(10033) package(4)  
 trstationcharacteristics(1)};

### 6.2.3.3 TokenRingMACOptions PACKAGE

pTokenRingMACOptions PACKAGE

BEHAVIOR bTokenRingLayer2MAC BEHAVIOR

DEFINED AS !This package identifies the protocol configuration of the ring station.!

ATTRIBUTES

aBurst4Option	GET-REPLACE,	-- 8
aBeaconHandling	GET-REPLACE,	-- 9
aClaimContender	GET-REPLACE,	-- 10
aEarlyTokenRelease	GET-REPLACE,	-- 11
aRingRate	GET,	-- 5
aMultipleFrameTransmission	GET-REPLACE,	-- 12
aRejectRemove	GET-REPLACE,	-- 13
aTokenErrorDetection	GET-REPLACE,	-- 14
aTokenHandling	GET-REPLACE,	-- 15
aErrorCountingMethod	GET-REPLACE;	-- 16

ATTRIBUTE GROUPS

"gTrProtocolOptions" -- 2

REGISTERED AS {iso(1) memberbody(2) us(840) 802dot5(10033) package(4)  
tokenringmacoptions(2)};

### 6.2.3.4 TrCharacteristics PACKAGE

pTrCharacteristics PACKAGE

BEHAVIOR bTokenRingLayer2MAC BEHAVIOR

DEFINED AS !This package identifies the ring characteristics for the station.!

ATTRIBUTES

aRingNumber	GET{-REPLACE},	-- 17
aErrorReportTimer	GET{-REPLACE},	-- 18
aAuthorizeFunctionClass	GET{-REPLACE},	-- 19
aAccessPriority	GET{-REPLACE},	-- 20
aPhysicalDropNumber	GET{-REPLACE},	-- 21
aRingStationStatus	GET;	-- 23

ATTRIBUTE GROUPS

"gTrCharacteristics" -- 3

REGISTERED AS {iso(1) memberbody(2) us(840) 802dot5(10033) package(4)  
trcharacteristics(3)};

### 6.2.3.5 TokenRingStatus PACKAGE

pTokenRingStatus PACKAGE

BEHAVIOR bTokenRingLayer2MAC BEHAVIOR

DEFINED AS !This package identifies the protocol state of the ring station.!

ATTRIBUTES

aJoinState	GET,	-- 24
aMonitorState	GET,	-- 25
aBeaconInfo,	GET,	-- 26
aTxBeaconType,	GET;	-- 27

## ATTRIBUTE GROUPS

gTrMACStatus	-- 4
--------------	------

## NOTIFICATIONS

evRingNonOperational,	-- 0
evRingOperational,	-- 1
evRingBeaconing,	-- 2
evProtocolError;	-- 4

REGISTERED AS {iso(1) memberbody(2) us(840) 802dot5(10033) package(4)  
tokenringstatus(4)};

**6.2.3.6 TokenRingStatistics PACKAGE**

pTokenRingStatistics PACKAGE

BEHAVIOR bTokenRingLayer2MAC BEHAVIOR

DEFINED AS !This package provides the error statistics of the ring station.!

ATTRIBUTES

aLineErrorCounter	GET,	-- 28
aBurstErrorCounter	GET,	-- 29
aAcErrorCounter	GET,	-- 30
aAbortTransmitCounter	GET,	-- 31
aInternalErrorCounter	GET,	-- 32
aLostFrameErrorCounter	GET,	-- 33
aRcvCongestionErrorCounter	GET,	-- 34
aFrameCopiedErrorCounter	GET,	-- 35
aFrequencydErrorCounter	GET,	-- 36
aTokenErrorCounter	GET;	-- 37

ATTRIBUTE GROUPS

gTrIsolatingErrors	-- 5
gTrNonIsolatingErrors	-- 6

REGISTERED AS {iso(1) memberbody(2) us(840) 802dot5(10033) package(4)  
tokenringstatistics(5)};

**6.2.4 TokenRingLayer2MAC BEHAVIOR**

bTokenRingLayer2MAC BEHAVIOR

DEFINED AS !This object class defines the MAC sublayer for token ring. The operation of the  
Token Ring MAC is defined in the ISO/IEC 8802-5 : 1995 Standard (802dot5).!;

**6.2.5 Attributes****6.2.5.1 Individual MAC Address ATTRIBUTE**

aIndMACAddress ATTRIBUTE

WITH ATTRIBUTE SYNTAX

MACDefinitions.MACAddress;

MATCHES FOR EQUALITY;

BEHAVIOR

bIndMACAddress BEHAVIOR

DEFINED AS !Specifies the MAC address of the token ring station.!

REGISTERED AS {iso(1) member-body(2) us(840) 802dot5(10033) attribute(7)  
indmacaddress (0)};

### 6.2.5.2 Universal Address ATTRIBUTE

aUniversalAddress ATTRIBUTE  
WITH ATTRIBUTE SYNTAX  
MACDefinitions.MACAddress;  
MATCHES FOR EQUALITY;  
BEHAVIOR  
bUniversalAddress BEHAVIOR  
DEFINED AS !Specifies the universal address assigned to the device.!.  
REGISTERED AS {iso(1) member-body(2) us(840) 802dot5(10033) attribute(7)  
universaladdress(1)};

### 6.2.5.3 Microcode Level ATTRIBUTE

aMicrocodeLevel ATTRIBUTE  
WITH ATTRIBUTE SYNTAX  
MACDefinitions.MicrocodeLevel;  
MATCHES FOR EQUALITY;  
BEHAVIOR  
bMicrocodeLevel BEHAVIOR  
DEFINED AS !Specifies the microcode level of this device.!.  
REGISTERED AS {iso(1) member-body(2) us(840) 802dot5(10033) attribute(7)  
microcodelevel (2)};

### 6.2.5.4 Product ID ATTRIBUTE

aProductInstanceId ATTRIBUTE  
WITH ATTRIBUTE SYNTAX  
MACDefinitions.ProductInstanceId;  
MATCHES FOR EQUALITY;  
BEHAVIOR  
bProductInstanceId BEHAVIOR  
DEFINED AS !Identifies Product type of the Token Ring device.!.  
REGISTERED AS {iso(1) member-body(2) us(840) 802dot5(10033) attribute(7)  
productinstanceid(3)};

### 6.2.5.5 Maximum Frame Size ATTRIBUTE

aMaxFrameSize ATTRIBUTE  
WITH ATTRIBUTE SYNTAX  
MACDefinitions.MaxFrameSize;  
MATCHES FOR EQUALITY;  
BEHAVIOR  
bMaxFrameSize BEHAVIOR  
DEFINED AS !Specifies the maximum frame size supported by the device.!.  
REGISTERED AS {iso(1) member-body(2) us(840) 802dot5(10033) attribute(7)  
maxframesize(4)};

**6.2.5.6 Ring Media Rate ATTRIBUTE**

aRingRate ATTRIBUTE  
 WITH ATTRIBUTE SYNTAX  
   MACDefinitions.RingRate;  
 MATCHES FOR EQUALITY;  
 BEHAVIOR  
   bRingRate BEHAVIOR  
 DEFINED AS !Specifies the current data transmission rate of this device.!.  
 REGISTERED AS {iso(1) member-body(2) us(840) 802dot5(10033) attribute(7) ringrate(5)};

**6.2.5.7 Functional Addresses ATTRIBUTE**

aFunctionalAddresses ATTRIBUTE  
 WITH ATTRIBUTE SYNTAX  
   MACDefinitions.FunctionalAddresses;  
 MATCHES FOR EQUALITY;  
 BEHAVIOR  
   bFunctionalAddresses BEHAVIOR  
 DEFINED AS !Specifies the active functional addresses of the token ring station.!.  
 REGISTERED AS {iso(1) member-body(2) us(840) 802dot5(10033) attribute(7) functionaladdresses(6)};

**6.2.5.8 Group Addresses ATTRIBUTE**

aGroupAddresses ATTRIBUTE  
 WITH ATTRIBUTE SYNTAX  
   MACDefinitions.GroupAddresses;  
 MATCHES FOR EQUALITY;  
 BEHAVIOR  
   bGroupAddresses BEHAVIOR  
 DEFINED AS !Specifies the group addresses recognized by the token ring station.!.  
 REGISTERED AS {iso(1) member-body(2) us(840) 802dot5(10033) attribute(7) groupaddresses(7)};

**6.2.5.9 Burst4 Option ATTRIBUTE**

aBurst4Option ATTRIBUTE  
 WITH ATTRIBUTE SYNTAX  
   MACDefinitions.Burst4Option;  
 MATCHES FOR EQUALITY;  
 BEHAVIOR  
   bBurst4Option BEHAVIOR  
 DEFINED AS !Specifies whether the station compensates for burst error when stripping.!.  
 REGISTERED AS {iso(1) member-body(2) us(840) 802dot5(10033) attribute(7) burst4option(8)};

#### 6.2.5.10 Beacon handling ATTRIBUTE

aBeaconHandling ATTRIBUTE  
WITH ATTRIBUTE SYNTAX  
MACDefinitions.BeaconHandling;  
MATCHES FOR EQUALITY;  
BEHAVIOR  
bBeaconhandling BEHAVIOR  
DEFINED AS !Indicates when the station will fully participate in beaconing.!;  
REGISTERED AS {iso(1) member-body(2) us(840) 802dot5(10033) attribute(7)  
beaconhandling(9)};

#### 6.2.5.11 Claim contender ATTRIBUTE

aClaimContender ATTRIBUTE  
WITH ATTRIBUTE SYNTAX  
MACDefinitions.ClaimContender;  
MATCHES FOR EQUALITY;  
BEHAVIOR  
bClaimContender BEHAVIOR  
DEFINED AS !Indicates whether the station will claim when it is not the station that detected the  
protocol error.!;  
REGISTERED AS {iso(1) member-body(2) us(840) 802dot5(10033) attribute(7)  
claimcontender(10)};

#### 6.2.5.12 Early token release ATTRIBUTE

aEarlyTokenRelease ATTRIBUTE  
WITH ATTRIBUTE SYNTAX  
MACDefinitions.EarlyTokenRelease;  
MATCHES FOR EQUALITY;  
BEHAVIOR  
bEarlyTokenRelease BEHAVIOR  
DEFINED AS !Specifies if the station releases the token before waiting for the reception of the  
transmitted frame (early token release option).!;  
REGISTERED AS {iso(1) member-body(2) us(840) 802dot5(10033) attribute(7)  
earlytokenrelease(11)};

#### 6.2.5.13 Multiple frame transmission fairness ATTRIBUTE

aMultipleFrameTransmission ATTRIBUTE  
WITH ATTRIBUTE SYNTAX  
MACDefinitions.MultipleFrameTransmission;  
MATCHES FOR EQUALITY;  
BEHAVIOR  
bMultipleFrameTransmission BEHAVIOR  
DEFINED AS !Indicates whether the station stops transmitting when a higher priority reservation is  
received.!;  
REGISTERED AS {iso(1) member-body(2) us(840) 802dot.5(10033) attribute(7)  
multiframeTxopt(12)};

**6.2.5.14 Reject remove frame ATTRIBUTE**

aRejectRemove ATTRIBUTE

WITH ATTRIBUTE SYNTAX

MACDefinitions.RejectRemove;

MATCHES FOR EQUALITY;

BEHAVIOR

bRejectRemove BEHAVIOR

DEFINED AS !Indicates whether the station will reject the Remove Station MAC frame.!

REGISTERED AS {iso(1) member-body(2) us(840) 802dot5(10033) attribute(7)

rejectremove(13)};

**6.2.5.15 Token error detection ATTRIBUTE**

aTokenErrorDetection ATTRIBUTE

WITH ATTRIBUTE SYNTAX

MACDefinitions.TokenErrorDetection;

MATCHES FOR EQUALITY;

BEHAVIOR

bTokenErrorDetection BEHAVIOR

DEFINED AS !Indicates whether the station counts errors in tokens.!

REGISTERED AS {iso(1) member-body(2) us(840) 802dot5(10033) attribute(7)

tokenerrordetect(14)};

**6.2.5.16 Token handling option ATTRIBUTE**

aTokenHandling ATTRIBUTE

WITH ATTRIBUTE SYNTAX

MACDefinitions.TokenHandling;

MATCHES FOR EQUALITY;

BEHAVIOR

bTokenHandling BEHAVIOR

DEFINED AS !Indicates how the station detects lost tokens.!

REGISTERED AS {iso(1) member-body(2) us(840) 802dot5(10033) attribute(7)

tokenhandling(15)};

**6.2.5.17 Error counting method ATTRIBUTE**

aErrorCountingMethod ATTRIBUTE

WITH ATTRIBUTE SYNTAX

MACDefinitions.ErrorCountingMethod;

MATCHES FOR EQUALITY;

BEHAVIOR

bErrorCountingMethod BEHAVIOR

DEFINED AS !Indicates how the station manages the error report timer.!

REGISTERED AS {iso(1) member-body(2) us(840) 802dot5(10033) attribute(7)

errorcounting(16)};

#### 6.2.5.18 Ring Number ATTRIBUTE

aRingNumber ATTRIBUTE  
WITH ATTRIBUTE SYNTAX  
MACDefinitions.RingNumber;  
MATCHES FOR EQUALITY;  
BEHAVIOR  
bRingNumber BEHAVIOR  
DEFINED AS !Indicates the ring number assigned to the device.!.  
REGISTERED AS {iso(1) member-body(2) us(840) 802dot5(10033) attribute(7)  
ringnumber(17)};

#### 6.2.5.19 Error Report Timer ATTRIBUTE

aErrorReportTimer ATTRIBUTE  
WITH ATTRIBUTE SYNTAX  
MACDefinitions.ErrorReportTimer;  
MATCHES FOR EQUALITY;  
BEHAVIOR  
bErrorReportTimer BEHAVIOR  
DEFINED AS !Specifies the time-out value for the station's error report timer.!.  
REGISTERED AS {iso(1) member-body(2) us(840) 802dot5(10033) attribute(7)  
errorreporttimer(18)};

#### 6.2.5.20 Authorize FunctionClasses ATTRIBUTE

aAuthorizeFunctionClasses ATTRIBUTE  
WITH ATTRIBUTE SYNTAX  
MACDefinitions.AuthorizeFunctionClasses;  
MATCHES FOR EQUALITY;  
BEHAVIOR  
bAuthorizeFunctionClasses BEHAVIOR  
DEFINED AS !Specifies the function classes allowed for this station.!.  
REGISTERED AS {iso(1) member-body(2) us(840) 802dot5(10033) attribute(7)  
authorizefunctionclasses(19)};

#### 6.2.5.21 Access Priority ATTRIBUTE

aAccessPriority ATTRIBUTE  
WITH ATTRIBUTE SYNTAX  
MACDefinitions.AccessPriority;  
MATCHES FOR EQUALITY;  
BEHAVIOR  
bAccessPriority BEHAVIOR  
DEFINED AS !Specifies the maximum priority of a token that may be used for LLC traffic.!.  
REGISTERED AS {iso(1) member-body(2) us(840) 802dot5(10033) attribute(7)  
accesspriority(20)};

**6.2.5.22 Physical Drop Number ATTRIBUTE**

aPhysicalDropNumber ATTRIBUTE  
WITH ATTRIBUTE SYNTAX  
MACDefinitions.PhysicalDropNumber;  
MATCHES FOR EQUALITY;  
BEHAVIOR  
bPhysicalDropNumber BEHAVIOR  
DEFINED AS !Specifies the station's physical location.!.  
REGISTERED AS {iso(1) member-body(2) us(840) 802dot5(10033) attribute(7)  
physicaldropnumber(21)};

**6.2.5.23 Nearest Active Upstream Neighbor ATTRIBUTE**

aNAUN ATTRIBUTE  
WITH ATTRIBUTE SYNTAX  
MACDefinitions.NAUN;  
MATCHES FOR EQUALITY;  
BEHAVIOR  
bNAUN BEHAVIOR  
DEFINED AS !Specifies the individual MAC address of this station's upstream neighbor.!.  
REGISTERED AS {iso(1) member-body(2) us(840) 802dot5(10033) attribute(7) naun(22)};

**6.2.5.24 Ring Station Status ATTRIBUTE**

aRingStationStatus ATTRIBUTE  
WITH ATTRIBUTE SYNTAX  
MACDefinitions.RingStationStatus;  
MATCHES FOR EQUALITY;  
BEHAVIOR  
bRingStationStatus BEHAVIOR  
DEFINED AS !Indicates the current state of the station's MAC protocol.!.  
REGISTERED AS {iso(1) member-body(2) us(840) 802dot5(10033) attribute(7)  
ringstationstatus(23)};

**6.2.5.25 Join State ATTRIBUTE**

aJoinState ATTRIBUTE  
WITH ATTRIBUTE SYNTAX  
MACDefinitions.JoinState;  
MATCHES FOR EQUALITY;  
BEHAVIOR  
bJoinState BEHAVIOR  
DEFINED AS !Indicates the current state of the MAC protocol's Join process.!.  
REGISTERED AS {iso(1) member-body(2) us(840) 802dot5(10033) attribute(7) joinstate(24)};

#### 6.2.5.26 Monitor State ATTRIBUTE

aMonitorState ATTRIBUTE

WITH ATTRIBUTE SYNTAX

MACDefinitions.MonitorState;

MATCHES FOR EQUALITY;

BEHAVIOR

bMonitorState BEHAVIOR

DEFINED AS !Indicates the current state of the MAC protocol's Monitor process.!

REGISTERED AS {iso(1) member-body(2) us(840) 802dot5(10033) attribute(7) monitorstate(25)};

#### 6.2.5.27 Beacon Information ATTRIBUTE

aBeaconInfo ATTRIBUTE

WITH ATTRIBUTE SYNTAX

MACDefinitions.BeaconInfo;

MATCHES FOR EQUALITY;

BEHAVIOR

bBeaconInfo BEHAVIOR

DEFINED AS !Indicates the fault domain.!

REGISTERED AS {iso(1) member-body(2) us(840) 802dot5(10033) attribute(7) beaconinfo(26)};

#### 6.2.5.28 TxBeacon Type ATTRIBUTE

aBeaconType ATTRIBUTE

WITH ATTRIBUTE SYNTAX

MACDefinitions.BeaconType;

MATCHES FOR EQUALITY;

BEHAVIOR

bTxBeaconType BEHAVIOR

DEFINED AS !Indicates the reason for beaconing.!

REGISTERED AS {iso(1) member-body(2) us(840) 802dot5(10033) attribute(7) txbeaontype(27)};

#### 6.2.5.29 Line Error Counter ATTRIBUTE

aLineErrorCounter ATTRIBUTE

WITH ATTRIBUTE SYNTAX

MACDefinitions.EventCounter;

MATCHES FOR EQUALITY;

BEHAVIOR

bLineErrorCounter BEHAVIOR

DEFINED AS !The number of line errors (CLE). This counter is incremented when a ring station detects an error within frame or token that has not previously been detected.!

REGISTERED AS {iso(1) member-body(2) us(840) 802dot5(10033) attribute(7) lineerrorcounter(28)};

**6.2.5.30 Burst Error Counter ATTRIBUTE**

aBurstErrorCounter ATTRIBUTE

WITH ATTRIBUTE SYNTAX

MACDefinitions.EventCounter;

MATCHES FOR EQUALITY;

BEHAVIOR

bBurstErrorCounter BEHAVIOR

DEFINED AS !The number of burst errors (CBE). This counter is incremented when a ring station detects the absence of transitions for 5 signal element times.!

REGISTERED AS {iso(1) member-body(2) us(840) 802dot5(10033) attribute(7) bursterrorcounter(29)};

**6.2.5.31 AC Error Counter ATTRIBUTE**

aAcErrorCounter ATTRIBUTE

WITH ATTRIBUTE SYNTAX

MACDefinitions.EventCounter;

MATCHES FOR EQUALITY;

BEHAVIOR

bAcErrorCounter BEHAVIOR

DEFINED AS !The number of AC errors (CACE). This counter is incremented as an indication that this station or its upstream neighbor is not properly setting or recognizing the A&amp;C bits.!

REGISTERED AS {iso(1) member-body(2) us(840) 802dot5(10033) attribute(7) acerrorcounter(30)};

**6.2.5.32 Abort Transmit Counter ATTRIBUTE**

aAbortTransmitCounter ATTRIBUTE

WITH ATTRIBUTE SYNTAX

MACDefinitions.EventCounter;

MATCHES FOR EQUALITY;

BEHAVIOR

bAbortTransmitCounter BEHAVIOR

DEFINED AS !The number of Abort Transmit errors (CABE). This counter is incremented when this station transmits an abort delimiter.!

REGISTERED AS {iso(1) member-body(2) us(840) 802dot5(10033) attribute(7) aborttransmitcounter(31)};

**6.2.5.33 Internal Error Counter ATTRIBUTE**

aInternalErrorCounter ATTRIBUTE

WITH ATTRIBUTE SYNTAX

MACDefinitions.EventCounter;

MATCHES FOR EQUALITY;

BEHAVIOR

bInternalErrorCounter BEHAVIOR

DEFINED AS !The number of Internal errors (CIE). This counter is incremented when this station recognizes a recoverable internal error.!

REGISTERED AS {iso(1) member-body(2) us(840) 802dot5(10033) attribute(7) internalerrorcounter(32)};

#### 6.2.5.34 Lost Frame Error Counter ATTRIBUTE

aLostFrameErrorCounter ATTRIBUTE  
WITH ATTRIBUTE SYNTAX  
MACDefinitions.EventCounter;  
MATCHES FOR EQUALITY;  
BEHAVIOR  
bLostFrameErrorCounter BEHAVIOR  
DEFINED AS !This counter contains the number of Lost Frame errors (CLFE). This counter is incremented when this station is transmitting and its return-to-repeat (TRR) timer expires.!.  
REGISTERED AS {iso(1) member-body(2) us(840) 802dot5(10033) attribute(7) lostframeerrorcounter(33)};

#### 6.2.5.35 Receive Congestion Error Counter ATTRIBUTE

aRcvCongestionErrorCounter ATTRIBUTE  
WITH ATTRIBUTE SYNTAX  
MACDefinitions.EventCounter;  
MATCHES FOR EQUALITY;  
BEHAVIOR  
bRcvCongestionErrorCounter BEHAVIOR  
DEFINED AS !This counter contains the number of Receiver Congestion errors (CRCE). This counter is incremented when this station recognizes that the frame being received is addressed to this station but has no buffer space available to copy the frame.!.  
REGISTERED AS {iso(1) member-body(2) us(840) 802dot5(10033) attribute(7) rcvcongestionerrorcounter(34)};

#### 6.2.5.36 Frame Copy Error Counter ATTRIBUTE

aFrameCopiedErrorCounter ATTRIBUTE  
WITH ATTRIBUTE SYNTAX  
MACDefinitions.EventCounter;  
MATCHES FOR EQUALITY;  
BEHAVIOR  
bFrameCopiedErrorCounter BEHAVIOR  
DEFINED AS !This counter contains the number of Frame Copy errors (CFCE). This counter is incremented when this ring station receives a MAC frame addressed to this station's individual address, but the A & C bits indicate another station also recognized the address as its own, indicating a possible duplicate address. LLC frames or frames with routing information may or may not be counted.!.  
REGISTERED AS {iso(1) member-body(2) us(840) 802dot5(10033) attribute(7) framecopiederrorcounter(35)};

**6.2.5.37 Frequency Error Counter ATTRIBUTE**

aFrequencydErrorCounter ATTRIBUTE

WITH ATTRIBUTE SYNTAX

MACDefinitions.EventCounter;

MATCHES FOR EQUALITY;

BEHAVIOR

bFrequencydErrorCounter BEHAVIOR

DEFINED AS !This counter contains the number of Frequency errors (CFE). This counter is incremented when this station detects the received signal stream's data signaling rate is out of tolerance.!

REGISTERED AS {iso(1) member-body(2) us(840) 802dot5(10033) attribute(7) frequencyderrorcounter(36)};

**6.2.5.38 Token Error Counter ATTRIBUTE**

aTokenErrorCounter ATTRIBUTE

WITH ATTRIBUTE SYNTAX

MACDefinitions.EventCounter;

MATCHES FOR EQUALITY;

BEHAVIOR

bTokenErrorCounter BEHAVIOR

DEFINED AS !This counter contains the number of Token errors (CTE). This counter is incremented when an active monitor recognizes an error condition resulting in the need to issue a new token.!

REGISTERED AS {iso(1) member-body(2) us(840) 802dot5(10033) attribute(7) tokenerrorcounter(37)};

**6.2.6 Attribute groups****6.2.6.1 Station Addresses ATTRIBUTE GROUP**

gTrStationAddresses ATTRIBUTE GROUP

GROUP ELEMENTS

IndMACAddress,

UniversalAddress,

FunctionalAddress,

GroupAddress,

NAUN;

DESCRIPTION !Specifies the addresses of the token ring station!;

REGISTERED AS {iso(1) member-body(2) us(840) 802dot5(10033) attributeGroup(Group(8)) stationcharacteristics(0)};

**6.2.6.2 Station Characteristics ATTRIBUTE GROUP**

gTrStationCharacteristics ATTRIBUTE GROUP

GROUP ELEMENTS

MicrocodeLevel,

ProductInstanceId,

MaxFrameSize;

DESCRIPTION !Specifies the characteristics of the token ring station!;

REGISTERED AS {iso(1) member-body(2) us(840) 802dot5(10033) attributeGroup(8) stationcharacteristics(1)};

### 6.2.6.3 MAC Protocol Options ATTRIBUTE GROUP

gTrProtocolOptions ATTRIBUTE GROUP

GROUP ELEMENTS

Burst4Option,  
BeaconHandling,  
ClaimContender,  
EarlyTokenRelease,  
RingRate,  
MultipleFrameTransmission,  
RejectRemove,  
TokenErrorDetection,  
TokenHandling,  
ErrorCountingMethod;

DESCRIPTION ! Specifies the token ring MAC protocol operating characteristics.!

REGISTERED AS {iso(1) member-body(2) us(840) 802dot5(10033) attributeGroup(8)  
protocoloptions(2)};

### 6.2.6.4 Station's Ring Characteristics ATTRIBUTE GROUP

gTrCharacteristics ATTRIBUTE GROUP

GROUP ELEMENTS

RingNumber,  
ErrorReportTimer,  
AuthorizeFunctionClass,  
AccessPriority,  
PhysicalDropNumber,  
RingStationStatus;

DESCRIPTION ! Specifies the current status of the token ring station.!

REGISTERED AS {iso(1) member-body(2) us(840) 802dot5(10033) attributeGroup(8)  
stationstatus(3)};

### 6.2.6.5 MAC Status ATTRIBUTE GROUP

gTrMACStatus ATTRIBUTE GROUP

GROUP ELEMENTS

JoinState,  
MonitorState,  
BeaconInfo,  
TxBeaconType;

DESCRIPTION ! Specifies the current status of the token ring MAC protocol.!

REGISTERED AS {iso(1) member-body(2) us(840) 802dot5(10033) attributeGroup(8)  
macstatus(4)};

**6.2.6.6 Isolating Error Counters ATTRIBUTE GROUP**

gTrIsolatingErrors ATTRIBUTE GROUP

GROUP ELEMENTS

LineErrorCounter,  
BurstErrorCounter,  
ACErrorCounter,  
AbortErrorCounter,  
InternalErrorCounter;

DESCRIPTION !Specifies the current values of the isolating error counters.!

REGISTERED AS {iso(1) member-body(2) us(840) 802dot5(10033) attributeGroup(8)  
isolatingerrors(5)};**6.2.6.7 Non Isolating Error Counters ATTRIBUTE GROUP**

gTrNonIsolatingErrors ATTRIBUTE GROUP

GROUP ELEMENTS

LostFrameErrorCounter,  
RcvCongestionErrorCounter,  
FrameCopiedErrorCounter,  
FrequencyErrorCounter,  
TokenErrorCounter;

DESCRIPTION !Specifies the current values of the non isolating error counters.!

REGISTERED AS {iso(1) member-body(2) us(840) 802dot5(10033) attributeGroup(8)  
nonisolatingerrors(6)};**6.2.7 Actions****6.2.7.1 Open ACTION**

acOpen ACTION

BEHAVIOR

bOpen BEHAVIOR

DEFINED AS !This action requests that the station starts the join ring process.!

MODE CONFIRMED;

WITH INFORMATION SYNTAX MACDefinitions.OpenData :

WITH REPLY SYNTAX MACDefinitions.OpenRspData;

REGISTERED AS {iso(1) member-body(2) us(840) 802dot5(10033) action(9) open(0)};

**6.2.7.2 Close ACTION**

acClose ACTION

BEHAVIOR

bClose BEHAVIOR

DEFINED AS !This action requests that the station removes itself from the ring.!

MODE CONFIRMED;

REGISTERED AS {iso(1) member-body(2) us(840) 802dot5(10033) action(9) close(1)};

## 6.2.8 Notifications

### 6.2.8.1 Ring Non Operational NOTIFICATION

evRingNonOperational NOTIFICATION  
BEHAVIOR  
bRingNonOperational BEHAVIOR  
DEFINED AS ! The ring is in a non-operational state (purging, claiming, or beaconing).!;  
WITH INFORMATION SYNTAX MACDefinitions.RingNonOpStatus  
REGISTERED AS {iso(1) member-body(2) us(840) 802dot5(10033) notification(10)  
ringnonop(0)};

### 6.2.8.2 Ring Operational NOTIFICATION

evRingOperational NOTIFICATION  
BEHAVIOR  
bRingOperational BEHAVIOR  
DEFINED AS ! The ring has returned to a normal operating status (normal repeat).!;  
WITH INFORMATION SYNTAX MACDefinitions.RingOpStatus  
REGISTERED AS {iso(1) member-body(2) us(840) 802dot5(10033) notification(10)  
ringop(1)};

### 6.2.8.3 Ring Beaconing NOTIFICATION

evRingBeaconing NOTIFICATION  
BEHAVIOR  
bRingBeaconing BEHAVIOR  
DEFINED AS ! Ring has failed and a station is transmitting beacon frames.!;  
WITH INFORMATION SYNTAX MACDefinitions.BeaconInfo  
REGISTERED AS {iso(1) member-body(2) us(840) 802dot5(10033) notification(10)  
ringbeaconing(2)};

### 6.2.8.4 Station Failure NOTIFICATION

evStationFailure NOTIFICATION  
BEHAVIOR  
bStationFailure BEHAVIOR  
DEFINED AS ! Station has failed and is no longer connected to the ring.!;  
WITH INFORMATION SYNTAX MACDefinitions.StationFailure  
REGISTERED AS {iso(1) member-body(2) us(840) 802dot5(10033) notification(10)  
stationfailure(3)};

### 6.2.8.5 Protocol Error NOTIFICATION

evProtocolError NOTIFICATION  
BEHAVIOR  
bProtocolError BEHAVIOR  
DEFINED AS ! Protocol error has been detected.!;  
WITH INFORMATION SYNTAX MACDefinitions.ProtocolError  
REGISTERED AS {iso(1) member-body(2) us(840) 802dot5(10033) notification(10)  
protocolerror(4)};

**6.2.9 MAC Definitions**

MACDefinitions

DEFINITIONS ::= BEGIN

IMPORTS

MACAddress

FROM IEEE802CommonDefinitions { iso(1) memberbody(2) us(840) ieee802-1F(10011)

asn1Module(2) commondefinitions(0) version(0) }

-- Imported implicitly from ISO/IEC 8824 : 1990

-- Definitions in Alphabetical Order

AccessPriority ::= INTEGER -- Range 0 to 7

AuthorizedFunctionClasses ::= OCTETSTRING(SIZE(2)) -- (see 3.3.4 X'06' subvector)

BeaconHandling ::= CHOICE {

beforeInitialization [0] IMPLICIT NULL, -- FBHO=0

afterInitialization [1] IMPLICIT NULL } -- FBHO=1

BeaconInfo ::= SEQUENCE {

beaconSourceAddr [0] IMPLICIT BeaconSA,

beaconType [1] IMPLICIT BeaconType,

beaconUNA [2] IMPLICIT BeaconRUA,

beaconDrop [3] IMPLICIT BeaconPDN }

BeaconPDN ::= OCTET STRING (SIZE 4) -- PhysicalDropNumber reported in beacon frame

-- (part of BeaconInfo)

BeaconRUA ::= MACAddress -- UNA subvector field reported in beacon frame

-- (part of BeaconInfo)

BeaconSA ::= MACAddress -- SA field of beacon frame

-- (part of BeaconInfo)

BeaconType ::= CHOICE { -- Beacon type subvector reported in beacon frame

typeUnknown [0] IMPLICIT NULL, -- unknown

type1 [1] IMPLICIT NULL, -- reconfiguration

type2 [2] IMPLICIT NULL, -- signal loss

type3 [3] IMPLICIT NULL, -- symbol streaming

type4 [4] IMPLICIT NULL } -- claim streaming

Burst4Option ::= CHOICE {

noCompensation [0] IMPLICIT NULL, -- FBEO=1

compensates [1] IMPLICIT NULL } -- FBEO=0

ClaimContender ::= CHOICE {

noContender [0] IMPLICIT NULL, -- FCCO=0

contender [1] IMPLICIT NULL } -- FCCO=1

EarlyTokenRelease ::= CHOICE {

notEnabled [0] IMPLICIT NULL, -- FETO=0

enabled [1] IMPLICIT NULL } -- FETO=1

ErrorCountingMethod ::= CHOICE {  
    triggered [0] IMPLICIT NULL, -- FECO=0  
    freeRunning [1] IMPLICIT NULL } -- FECO=1

ErrorReportTimer ::= INTEGER -- Number in 0.01 s increments, range 0 to 655.35 s

EventCounter ::= INTEGER -- 32-bit counter

FunctionalAddresses ::= OCTETSTRING(SIZE(4)) -- (see 3.2.4.1)

GroupAddresses ::= LIST OF { MACAddress }

JoinState ::= CHOICE {  
    notSpecified [0] IMPLICIT NULL, -- Not specified or unknown  
    bypass [1] IMPLICIT NULL, -- JS=BP  
    lobeTest [2] IMPLICIT NULL, -- JS=LT  
    detectMonPresent [3] IMPLICIT NULL, -- JS=DMP  
    awaitNewMonitor [4] IMPLICIT NULL, -- JS=ANM  
    duplicateAddrTest [5] IMPLICIT NULL, -- JS=DAT  
    neighborNotification [6] IMPLICIT NULL, -- JS=NN  
    requestinitialization [7] IMPLICIT NULL, -- JS=RQI  
    joinComplete [8] IMPLICIT NULL, -- JS=JC  
    bypassWait [9] IMPLICIT NULL } -- JS=BPW

LastMonitorAddress ::= MACAddress -- value of X'0A' subvector - SA of last AMP/SMP  
-- (used in ProtocolErrorStatus part of ProtocolError)

LocalAddress ::= MACAddress -- Local assigned address, value of all zeros indicates not specified  
-- (part of openData)

MaxFrameSize ::= INTEGER -- Range 133 to 65 535 octets  
-- The maximum allowable values for MaxFrameSize is  
-- dependent on ring speed as follows:  
-- 1) 4550 at 4 Mbit/s  
-- 2) 18 200 at 16 Mbit/s

MicrocodeLevel ::= OCTETSTRING(SIZE 1..32)

MonitorErrorCode ::= CHOICE { -- value of X'30' Error Code subvector  
-- (used in ProtocolErrorStatus part of ProtocolError)  
    claimReceived [0] IMPLICIT NULL, -- Claim Frame received  
    duplicateMonitor [2] IMPLICIT NULL, -- Another Active Monitor detected  
    duplicateAddress [3] IMPLICIT NULL } -- Another station with same address

MonitorState ::= CHOICE {  
    notSpecified [0] IMPLICIT NULL, -- Not specified or unknown  
    ringPurge [1] IMPLICIT NULL, -- MS=TRP  
    claimTransmit [2] IMPLICIT NULL, -- MS=TCT  
    beaconTransmit [3] IMPLICIT NULL, -- MS=TBN  
    beaconTest [4] IMPLICIT NULL, -- MS=BNT  
    beaconRepeat [5] IMPLICIT NULL, -- MS=RBN  
    claimRepeat [6] IMPLICIT NULL, -- MS=RCT  
    activeMonitor [7] IMPLICIT NULL, -- MS=RPT & FAM=1  
    standbyMonitor [8] IMPLICIT NULL } -- MS=RPT & FAM=0

```

MultipleFrameTransmission ::= CHOICE {
    relinquish [0] IMPLICIT NULL, -- FMFTO=0
    continue [1] IMPLICIT NULL } -- FMFTO=1

NAUN ::= SEQUENCE {
    sua [0] IMPLICIT SUA
    uPhysicalDrop [1] IMPLICIT PhysicalDropNumber } -- from AMP/SMP frame

OpenData ::= SEQUENCE { -- (used in Open Action)
    localaddress [0] IMPLICIT LocalAddress
    ringrate [1] IMPLICIT RingRate }

OpenRspData ::= SEQUENCE { -- (used in Open Action)
    productId [0] IMPLICIT ProductInstanceId
    micLevel [1] IMPLICIT MicrocodeLevel
    openStatus [2] IMPLICIT OpenStatus
    ringRate [3] IMPLICIT RingRate
    una [4] IMPLICIT NAUN }

OpenStatus ::= CHOICE { -- (used in OpenRspData)
    sSuccess [0] IMPLICIT NULL, --Successful
    sNotOperational [1] IMPLICIT NULL, --Internal error - HW or SW failure, etc.
    sInvalidAddress [2] IMPLICIT NULL, --MAC address is invalid (group or not specified)
    sRateNotSupported [3] IMPLICIT NULL, --The requested data rate is not supported
    sFailGeneral [4] IMPLICIT NULL, --Failure in activation - General
    sFailLobeTest [5] IMPLICIT NULL, --Failure in activation - Lobe Test Failure
    sFailDataRate [6] IMPLICIT NULL, --Failure in activation - Medium Rate Error
    sFailDuplicate [7] IMPLICIT NULL, --Failure in activation - Duplicate Address
    sFailDATTimeout [8] IMPLICIT NULL, --Failure in activation - DAT Timeout - TJR expired
    sFailNNTIMEout [9] IMPLICIT NULL, --Failure in activation - Neighbor Notifi. timeout
    sFailInitTimeout [10] IMPLICIT NULL, --Failure in activation - Initialization timeout
    sFailRingBeaconing [11] IMPLICIT NULL, --Failure in activation - Beacon received
    sFailPurgeTimeout [12] IMPLICIT NULL, --Failure in activation - Purge failure - TRP expired
    sFailClaimTimeout [13] IMPLICIT NULL, --Failure in activation - Claim failure - TCT expired
    sFailBeaconTimeout [14] IMPLICIT NULL, --Failure in activation - Beacon failure - TBT expired
    sFailSignalLoss [15] IMPLICIT NULL, --Failure in activation - Signal Loss
    sFailInternal [16] IMPLICIT NULL, --Failure in activation - Internal Error
    sFailTxFault [17] IMPLICIT NULL, --Failure in activation - Station transmit failure
    sRemove [18] IMPLICIT NULL } --Failure in activation - Remove Frame received

PhysicalDropNumber ::= OCTET STRING (SIZE(4))
ProductInstanceId ::= OCTET STRING (SIZE(1..31))

ProtocolError ::= SEQUENCE { -- (used in ProtocolError Event)
    protocolErrType [0] IMPLICIT ProtocolErrType,
    protocolErrStatus [1] IMPLICIT ProtocolErrStatus }

ProtocolErrType ::= CHOICE { -- (part of ProtocolError used in ProtocolError Event)
    sActiveMonitorError [0] IMPLICIT NULL, -- Active Monitor Error
    sNotificationIncomplete [1] IMPLICIT NULL } -- Neighbor Notification Incomplete

ProtocolErrStatus ::= SEQUENCE { -- (part of ProtocolError used in ProtocolError Event)
    errorCode [0] IMPLICIT MonitorErrorCode,
    lastMonitorAddress [0] IMPLICIT LastMonitorAddress }

```

RejectRemove ::= CHOICE {  
    removes [0] IMPLICIT NULL, -- FRRO=0  
    rejects [1] IMPLICIT NULL } -- FRRO=1

RingNonOpStatus ::= CHOICE { -- (used in RingNonOperational Event)  
    sRingNonOp [0] IMPLICIT NULL, -- Claim - Purge Failure  
    sPurgeFailure [1] IMPLICIT NULL, -- Claim - Purge Failure  
    sRingClaiming [2] IMPLICIT NULL, -- Claim - Claim Received  
    sClaimNoMonitor [3] IMPLICIT NULL, -- Claim - No Active Monitor (TJR, TNT, TSM=E)  
    sClaimSignalLoss [4] IMPLICIT NULL, -- Claim - Signal Loss  
    sRingBeaconing [5] IMPLICIT NULL } -- Beacon received

RingNumber ::= OCTET STRING (SIZE(2))

RingOpStatus ::= CHOICE { -- (used in RingOperational Event)  
    sRingOp [0] IMPLICIT NULL, -- Ring operational - Monitor status not specified  
    sStandbyMonitor [1] IMPLICIT NULL, -- This station is a standby monitor (FAM=0)  
    sActiveMonitor [2] IMPLICIT NULL } -- This station is the Active Monitor (FAM=1)

RingRate ::= CHOICE {  
    rate4Mbps [0] IMPLICIT NULL, -- FMRO=0  
    rate16Mbps [1] IMPLICIT NULL } -- FMRO=1

RingStationStatus ::= OCTET STRING (SIZE(6)) -- (See 3.3.4 X'29' subvector)

StationFailure ::= CHOICE { -- (used in StationFailure Event)  
    sStationDown [0] IMPLICIT NULL, -- Station Failure - cause not specified  
    sRemove [0] IMPLICIT NULL, -- Remove Frame received  
    sWireFault [1] IMPLICIT NULL, -- Wire Fault  
    sFailInternal [2] IMPLICIT NULL, -- Internal Failure  
    sFailTest [3] IMPLICIT NULL } -- Beacon Test Failure

SUA ::= MACAddress -- Address of upstream neighbor

TokenErrorDetection ::= CHOICE {  
    notCounted [0] IMPLICIT NULL, -- FTEO=1  
    counted [1] IMPLICIT NULL } -- FTEO=0

TokenHandling ::= CHOICE {  
    activeTimer [0] IMPLICIT NULL, -- FTHO=0  
    periodicInspection [1] IMPLICIT NULL } -- FTHO=1

## 7. Station attachment specifications

This clause defines the physical medium components (PMC) of the station attachment PHY layer as well as restrictions on the jitter accumulation in a ring caused by any PHY. This includes specifications for jitter accumulation, a transmitter, a receiver, a transmission channel, and medium interface connectors (MICs). The objective of these specifications is to provide a transmission system which

- a) Ensures compatibility of independently developed physical and electrical interfaces.
- b) Provides a communication channel that consists of a transmitter, receiver, and channel with an equivalent bit error rate (BER) of less than or equal to  $10^{-9}$  and a ring with a ring equivalent BER of  $10^{-8}$ .<sup>8</sup>

The analyses used in determining these specifications are based on linear transfer functions for the timing recovery circuits.

Subclause 7.1, which applies to all PHYs, provides the media-independent specifications that limit the jitter buildup in rings to a level that all PHYs can tolerate, regardless of media type. Clause 7.2 provides the media-dependent specifications of the PMC for transmission over STP and UTP media.<sup>9</sup>

### 7.1 Media-independent PHY specifications

This subclause describes the media independent PHY<sup>10</sup> requirements. These specifications are designed to limit jitter buildup in rings to levels that all PHYs, regardless of media type, can tolerate.

#### 7.1.1 Accumulated jitter

Accumulated jitter is the jitter that builds up as it passes through each ring PHY subsequent to the active monitor. Since each ring PHY receiver is unable to fully compensate for the signal distortion introduced by the sending transmitter, interconnecting channel and its own receiver, jitter is introduced at each PHY. Since each PHY subsequent to the active monitor transmits with the clock derived from the jittered signal at the receiver, a filtered form of the jitter at each PHY is transferred to subsequent PHYs, causing the jitter to accumulate as the signal travels around the ring. The accumulated jitter is measured as the time displacement of the transmitted waveform driving a conformant channel with respect to the active monitor station crystal clock as any valid data pattern passes through the ring PHYs. The accumulated jitter has a total magnitude (AJ) and a magnitude of the rate of phase change called Accumulated Phase Slope (APS). The accumulated jitter is typically dominated by the jitter that is correlated to data pattern ("correlated jitter") but also has components from sources not related to the data pattern ("uncorrelated jitter"). Limits on AJ and APS, specified in this clause, control the combination of the correlated and uncorrelated jitter.

The PHYs must track the accumulated jitter<sup>11</sup> and the elastic buffer (5.8.3) in the Active Monitor Station must be able to compensate for this jitter. To ensure this, the total magnitude of the Accumulated Jitter

<sup>8</sup> Equivalent BER is used because the effect of both single and multiple bit errors within a frame is to cause a frame error and a retransmission. Equivalent BER can be determined by assuming that all frame errors are caused by a single bit error and computing accordingly. For example, the worst-case allowable station packet error rate for a sequence of packets, each 1250 octets long (10 kbits long), is  $10^{-5}$ .

<sup>9</sup> Alternate media are the subject of future study.

<sup>10</sup> Since the specifications in 7.1 are a function not only of PMC parameters but also of PSC parameters such as station delay, the term PHY is used in 7.1 instead of PMC.

<sup>11</sup> *Accumulated jitter* is equivalent to the *cumulative latency variations* of 5.8.3.

(AJ) is limited to an amount smaller than the elasticity<sup>12</sup> of the elastic buffer in the active monitor station. AJ is the peak-to-peak magnitude of the jitter after the last PHY in the ring.

Accumulated phase slope is defined as the phase slope (rate of phase change) that is accumulated by the PHYs in relation to the active monitor's imbedded crystal clock. The magnitude of the filtered accumulated phase slope (FAPS)<sup>13</sup> must be kept below a maximum value in order for adequate remaining eye-opening margin to be available to tolerate jitter from reflections, NEXT, and other sources under worst-case data patterns.

To aid interoperability, the phase slope changes due to jitter not present in the test channel for the FAPS specification described below but present in actual channels (such as the jitter caused by crosstalk and reflections) must be limited. This is accomplished by limiting the allowable increase in phase slope in a ring per unit of increased jitter at each PHY by specifying a parameter termed DFAPS (Delta FAPS), which is the increase in phase slope caused by a 1 ns increase in jitter at each PHY.

The AJ, FAPS, and DFAPS values are defined after the minimum number of PHYs detailed in table 7-4 (for STP and UTP cases). Where PHYs with simple well-behaved clock recovery systems are added to the ring, measurements on a lower number of PHYs may allow extrapolation to the values expected after the full number of PHYs. For these measurements, each PHY has the same Test Channel. Each measurement must be performed on a single sequence of adjacent zero-crossings of the data over any valid data pattern. The zero-crossing timing data is filtered by a low-pass filter with a single pole at F6 for FAPS. Between each measurement the symbol polarity shall be randomized at each station. These measurements shall be repeated at least 15 times and the average of the maximum magnitudes (filtered in the case of FAPS) used to determine AJ and FAPS.

The PHY shall meet the following AJ and FAPS specifications for any test channel conformant with Test\_Chan\_A (specified in 7.2.4.4 for STP and UTP cases), during the transmission of any valid data pattern. The phase slope generated by the chain of PHYs shall not increase by more than DFAPS for each 1 ns increase in jitter at each PHY over the range of jitter possible at the PHY for any channel conformant with the channel specifications in 7.2.4. (The range of jitter and the phase slope response to it is implementation-dependent and may require a verification method specific to the implementation. A method suitable for a number of common implementations is outlined in C.2.5 for informational purposes.)

**Table 13—Accumulated jitter specifications**

	4 Mbit/s	16 Mbit/s
AJ	< 600 ns	< 750 ns
FAPS	< 0.0035 ns/ns	< 0.0082 ns/ns
DFAPS	0.0012 ns/ns	0.0048 ns/ns
F6	90 kHz	360 kHz

<sup>12</sup> The elasticity is the quantity *B* in 5.8.3.1.

<sup>13</sup> *Filtered* means that the phase-slope waveform is filtered by a single-pole low-pass filter to remove high-frequency jitter, which is typically not accumulated, from the measurement. If the phase slope is an analog waveform, it should be filtered by a standard single-pole filter. Care must be taken to ensure that the band-limiting of the demodulation process is significantly above the pole of the low-pass filter. If the phase slope is a digitally sampled waveform, such as that derived from a time interval analyzer, the waveform is usually interpolated to a waveform containing equally spaced sample points and then filtered by the digital equivalent of a single-pole analog filter. Note that the phase slope waveform is filtered to remove high-frequency jitter components, which would give misleadingly high values of the phase slope when taking the derivative.

### 7.1.2 Accumulated Uncorrelated Jitter

Accumulated uncorrelated jitter is the component of the jitter that is not correlated to the data pattern. Typical sources of uncorrelated jitter include time-dependent transmit duty cycle distortion, high-frequency cyclic jitter, and phase noise in the local oscillator's output. Accumulated uncorrelated jitter is specified<sup>14</sup> in terms of the accumulated uncorrelated jitter alignment (AUJA) error it would produce in an ideal first-order clock-recovery circuit with a 3 dB bandwidth of F6 receiving the uncorrelated jitter built up from a chain of similar retiming elements where the alignment error is defined as the difference between the input and output jitter waveforms of the clock-recovery circuit at any particular point in time. This measurement effectively high-pass filters the accumulated jitter, resulting in an alignment error with a zero mean. The minimum length of this chain is detailed in table 13 (for STP and UTP cases). Where PHYs with simple well-behaved clock-recovery systems are added to the ring, measurements on a lower number of PHYs may allow extrapolation to the values expected after the full number of PHYs. For informational purpose, C.2.7 provides an ideal first-order clock-recovery model that may be used to determine AUJA error.

The PHY shall meet the following AUJA specifications for any test channel conformant with Test\_Chan\_A (STP and UTP cases) for data streams composed of all ones and data streams composed of all zeros. The probability of the zero-to-peak alignment error at each symbol element interval exceeding AUJA shall be less than 0.3%.

**Table 14—Accumulated uncorrelated jitter specifications**

	4 Mbit/s	16 Mbit/s
AUJA	10 ns	1.5 ns
F6	90 kHz	360 kHz

### 7.1.3 PHY net delay

Interoperability between PHYs with different implementations on the same ring requires that the derivative of the magnitude of the FAPS with respect to the net delay time (NDT; as defined in C.2.2) of each node at the operating point shall be greater than or equal to zero (i.e., increasing the NDT does not decrease the magnitude of the FAPS).<sup>15</sup>

## 7.2 Media-dependent PMC specifications

This subclause describes the media-dependent specifications for STP and UTP station PMCs. All resistive loads discussed in this clause have a  $\pm 1\%$  tolerance unless otherwise noted. The station port signal names used in this specification map to the MIC\_S and MIC\_U contacts as shown in table 15.

<sup>14</sup> Note that accumulated uncorrelated jitter is also indirectly limited by the accumulated jitter specifications.

<sup>15</sup> C.2.6 contains a clarification of the PHY net delay specification.

**Table 15—Station port signal to MIC\_S and MIC\_U contact mapping**

MIC_U contact	MIC_S contact	Station port signal
1	—	Not used by this standard
2	—	Not used by this standard
3	B	TX-A
4	R	RX-A
5	G	RX-B
6	O	TX-B
7	—	Not used by this standard
8	—	Not used by this standard

Table 16 details the minimum number of PMCs that must be supported on STP and UTP at 4 and 16 Mbit/s.

**Table 16—Ring PMC counts**

Media	Data rate	Min. # of supported PMCs
STP	4 Mbit/s	250
STP	16 Mbit/s	250
UTP	4 Mbit/s	144
UTP	16 Mbit/s	250

Note that each retiming port in the ring counts as a single PMC, so that, for example, a 4 Mbit/s UTP ring using all ARC ports supports a minimum of 72 stations connected to 72 ARC ports for a total of 144 PMCs.

### 7.2.1 Phantom signaling and wire fault detection

Stations that use STP and UTP transmission media and are controlled by a ring access control (RAC) function (see 5.9) shall use the signaling method described below to effect access to the ring through the concentrator. They use the wire fault detection method described below to detect certain fault conditions in the transmission channel wiring.

As described in 5.9, when the RAC receives Insert\_station and Remove\_station requests from the MAC, it shall signal *ring insertion* and *ring bypass* requests, respectively, to the TCU in the concentrator. Phantom signaling, which is transparent to the Manchester data signals on the channel, shall be used to send the ring insertion and ring bypass requests to the TCU. The TCU effects ring insertion and ring bypass as described in 8.3.1. An example of a phantom signaling circuit is shown in figure 29. It consists of two circuits whose function, described in 7.2.1.1 and 7.2.1.2, is designed to ensure that the station can detect a single open wire and certain short-circuit conditions in the channel between the station and the TCU.

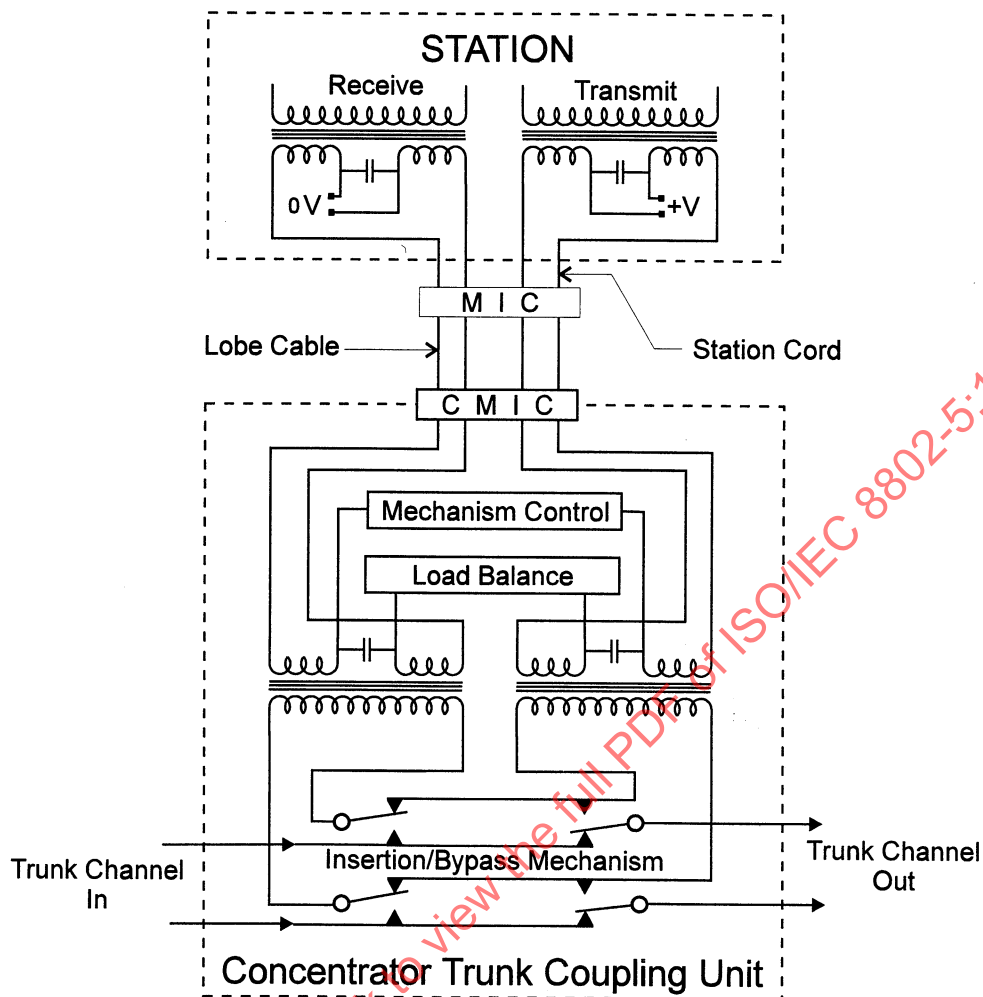

Figure 29—Example of a station-to-TCU connection

### 7.2.1.1 Ring insertion and ring bypass

When the RAC receives an Insert\_station request from the MAC, the RAC shall signal *ring insertion* to the TCU by applying *power* to both phantom circuits. Unless directed by the MAC, the RAC should not signal ring insertion. Under any circumstances, the RAC shall not signal *ring insertion* for more than 25 ms over any 5 s period unless the station is opening on the ring.<sup>16</sup> In response to Remove\_station, the RAC shall signal *ring bypass* to the TCU by applying *no power* to both phantom circuits. The time from the receipt of Remove\_station to the indication of *no power* shall not exceed a time that is the station's Remove Wait Time (see 3.4.2.11, TRW timer) minus 185 ms when the station is connected to a resistive load of 5.4 kΩ on each circuit.

The phantom circuits shall have the following sources and returns:

- a) Source TX-A
- b) Source TX-B

<sup>16</sup> The intent of this statement is to avoid glitches in the phantom signal that could cause the concentrator to insert when the station is not ready to repeat data and thus break the ring until the concentrator removes. An allowance of 25 ms is made for glitches that might occur during station power-up; however, it is desirable that the station not glitch the phantom signal at all. See 8.3.2 for recommendations on concentrator glitch tolerance.

- c) Return RX-A
- d) Return RX-B

The differential dc voltage between any source and any return shall not exceed 7.0 V. In this clause, *voltage* is defined as the difference in potential between a circuit's source and return MIC terminals. Furthermore, *current* is defined as the electrical current flowing out of the source and back into the return.

*Power* is defined as follows: Voltage is always impressed on both circuits at the same time where *the same time* means within 0.1 s of each other. This voltage shall not exceed 7 V under any compliant load conditions. The current shall not exceed 20 mA under any compliant load condition. When the current is less than 2 mA, the voltage shall be greater than 3.5 V under compliant load conditions. When the current is less than 1 mA, the voltage shall be greater than 4.1 V under compliant load conditions. Power shall be applied to both load circuits. Under identical compliant load conditions, the lower of the two circuit voltages shall be within 5% of the higher circuit voltage. The station PMC shall not be required to supply more than 2 mA to achieve insertion. Each phantom drive source shall maintain the currents and voltages specified above to either phantom return. Whenever the load impedance presented to the station at its MIC terminals does not allow the voltage to reach a level of 3.5 V, the station shall supply at least 2 mA phantom current to its MIC terminals while power is applied.

*No-power* is defined as follows: The voltage shall not exceed 1 V under any compliant load condition. The current shall not exceed 340  $\mu$ A under any compliant load condition.

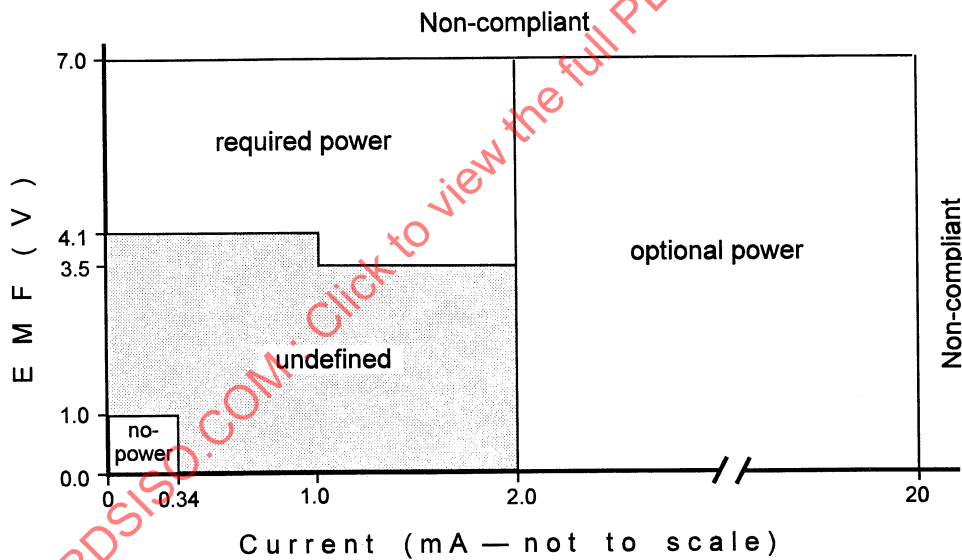

Figure 30—Phantom power/no-power regions

*Compliant load conditions* are defined as follows. Conditions are illustrated in figure 31.

- a) *MIC loopback* is defined as an independent passive load to each circuit under *power* and *no-power* conditions. The resistance of each of these passive loads shall be less than 50  $\Omega$ .
- b) *TCU presence* is defined as an independent passive load to each circuit under *power* conditions. The resistance of each of these passive loads shall be greater than 2.9 k $\Omega$  and less than 5.4 k $\Omega$  (100  $\Omega$  for cabling plus 5.3 k $\Omega$  for TCU). This load may be highly capacitive and nonlinear but should not be inductive.

- c) *TCU loopback* is defined as an independent passive load to each circuit under *no-power*. The resistance of each of these passive loads shall be greater than 2.9 kΩ and less than 5.4 kΩ (100 Ω for cabling plus 5.3 kΩ for TCU). This load may be highly capacitive and nonlinear but should not be inductive.
- d) *Inserted* is defined as an independent passive load to each circuit under *power* conditions. The resistance of each of these passive loads shall be greater than 2.9 kΩ and less than 5.4 kΩ. Furthermore, the resistance of these two loads shall be matched within ± 15%.
- e) *No load* is defined as an independent passive load to each circuit under *power* and *no-power* conditions. The resistance of each of these passive loads shall be greater than 50 kΩ.

The definition of resistance is  $V/I$  at the measurement point. The leakage resistance between the two loads shall be greater than 100 kΩ.

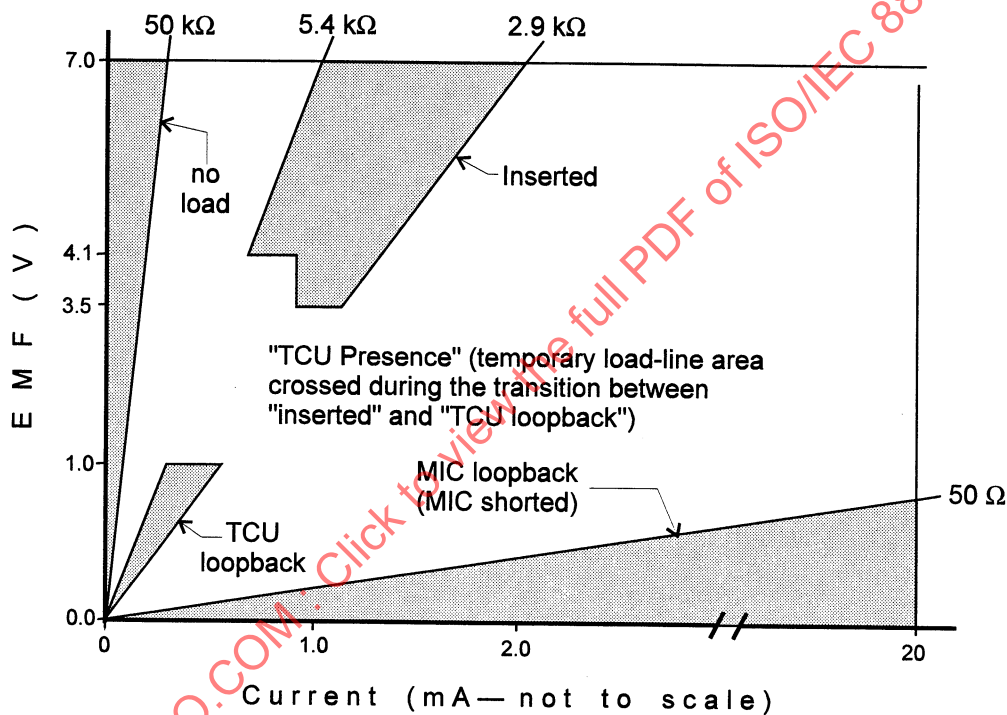

Figure 31—Operating regions for compliant load conditions

### 7.2.1.2 Wire\_fault detection

To detect some opens and shorts in the channel between the station and the TCU, as well as some opens and shorts in the TCU, the phantom signaling circuit shall consist of two independent circuits as shown in figure 29. The pairing of sources to returns in the figure is only an example and either permutation of pairing may be used.

While the PMC is requesting “ring insertion” as described previously, the PMC shall indicate “Not detected” for Wire\_fault as described in 5.1.4.1 when the resistances of both phantom circuits are within the range of 2.9–5.4 kΩ.

While the PMC is requesting “ring insertion,” the PMC shall indicate “detected” for Wire\_fault as described in 5.1.4.1 for the following conditions.

- a) The resistance of either phantom circuit is less than 50  $\Omega$ .
- b) The resistance of either phantom circuit is greater than 50 k $\Omega$ .

The indications for conditions outside the above resistance ranges are unspecified.

## 7.2.2 Transmitter specification

The PMC shall provide a transmitter meeting the specifications of this clause. Phantom signaling for ring access control is described separately in 7.2.1. The phantom signals (if provided) shall be in a powered and loaded state for all measurements of the transmitter specified in this clause. The dc phantom load used to test the transmitter specifications shall be equivalent to a pair of resistors with a 15% mismatch. The smaller resistor shall be 2.9 k $\Omega$ . The ac transmitter load between TX-A and TX-B used to test the transmitter specifications shall be 100  $\Omega$  for UTP and 150  $\Omega$  for STP. These specifications are not intended to cover electromagnetic compatibility concerns (see E.3.1). All measurements of transmitter properties are made at the appropriate reference MIC.

### 7.2.2.1 Differential output signal duty cycle distortion

Transmitter duty cycle distortion (TDCD) is defined as one half the difference between the arithmetic averaged positive and negative pulse widths of the data signal. The pulse widths are defined from the ac-coupled zero-crossings of the differential waveform measured at the appropriate MIC with a resistive load. The averaged widths are determined by averaging at least 128 measurements of each of the positive and negative widths.

Transmitter duty cycle distortion shall be measured at the transmitter output of a PMC with the PMC retiming data from its timing recovery circuit and transmitting a constant stream of all Data\_zero (see 5.3) or all Data\_one symbols (to avoid intersymbol interference disturbance with the measurement). The transferred jitter from the transmitter transmitting to the PMC under test should be minimized. The absolute value of the duty cycle distortion for either data stream shall be within the following specifications:

**Table 17—Transmitter duty cycle distortion (TDCD) specifications**

	4 Mbit/s	16 Mbit/s
TDCD (STP 150 $\Omega$ load)	< 6 ns	< 1.5 ns
TDCD (UTP 100 $\Omega$ load)	< 6 ns	< 1.5 ns

### 7.2.2.2 Differential output waveform

The differential waveform is measured at the appropriate MIC with a resistive load. The transmitter waveform shall meet the criteria in the following two subclauses:

#### 7.2.2.2.1 Waveform edge jitter

For a data stream alternating between a stream of Data\_zero symbols and a stream of Data\_one symbols, Tdiff01 is the difference in transmitter data edge placement (relative to an internal transmit clock or conceptual equivalent) between a zeros data pattern and a ones data pattern. Referring to figure 32, define Tdiff01 as

$$T_{diff01} = (T_{one} - T_{oclk}) - (T_{zero} - T_{zclk})$$

where  $T_{one}$  is the ac-coupled zero-crossing point of the  $Data\_one$ 's edge being measured,  $T_{oclk}$  is the ac-coupled zero-crossing point of the transmit clock's edge that latches out the  $Data\_one$ 's edge being measured,  $T_{zero}$  is the ac-coupled zero-crossing point of the  $Data\_zero$ 's edge being measured, and  $T_{zclk}$  is the ac-coupled zero-crossing point of the transmit clock's edge that latches out the  $Data\_zero$ 's edge being measured. Positive  $T_{diff}$  is defined as  $(T_{one} - T_{oclk})$  being greater than  $(T_{zero} - T_{zclk})$ ; that is, the  $Data\_zeros$  pattern edges occur closer to their corresponding ideal clock edges than the  $Data\_ones$  pattern edges.

To avoid introducing the effects of transmitter duty cycle distortion into this measurement,  $T_{diff01}$  is calculated only with pairs of  $T_{one}$  and  $T_{zero}$  measurements made either on the rising edges of data only or on the falling edges of data only.  $T_{diff01}$  shall be calculated for both rising and falling edges.  $T_{diff01}$  may show variation across repeated measurements due to phase noise. This variation may be removed by using the mean value of repeated measurements on rising edges or on falling edges. The mean of the rising edge measurements and the mean of the falling edge measurements shall both independently meet the  $T_{diff01}$  specification.

Note that in the absence of the relevant transmit clock, the output of a sufficiently narrow band PLL or other timing recovery circuit receiving the transmitted data may be used in place of the transmit clock. Sufficiently narrow band means low enough to filter out the pattern-dependent jitter in the particular data patterns used for these tests. The station must be transmitting using its local crystal oscillator in this case.

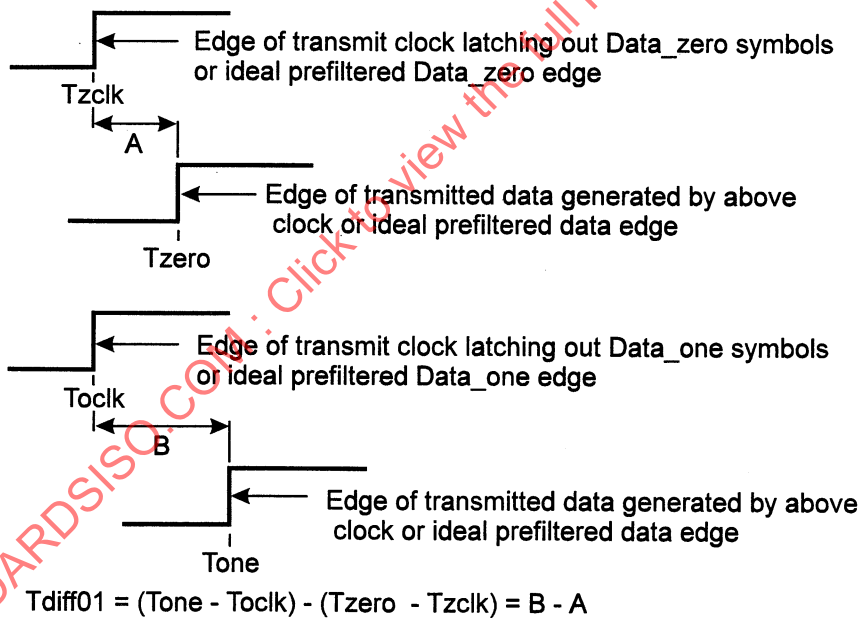

NOTE— $T_{one}$  and  $T_{zero}$  must either (1) both be measured on rising edges of data or (2) both be measured on falling edges of data to ensure that duty cycle distortion does not affect the measurement.

**Figure 32— $T_{diff}$  measurement illustration**

$T_{diff01}$  shall meet the following specification:

- a) at 4 Mbit/s  $-0.5 \text{ ns} < T_{diff01} < 0.5 \text{ ns}$
- b) 16 Mbit/s  $0.3 \text{ ns} < T_{diff01} < 1.0 \text{ ns}$

The  $T_{diff01}$  is allowed to vary over a range only to allow for manufacturing tolerances. To aid interoperability it is important that manufacturers center their transmitter designs in the center of the given range.

Similarly, for any valid data stream consisting of random data, start delimiters (SDs), and end delimiters (EDs):

$$T_{diffmax} = (TR1 - T_{clk1}) - (TR2 - T_{clk2})$$

where  $TR1$  is the ac-coupled zero-crossing point of the first data edge being measured,  $T_{clk1}$  is the ac-coupled zero-crossing point of the transmit clock's edge that latches out the first data edge being measured,  $TR2$  is the ac-coupled zero-crossing point of the second data edge being measured, and  $T_{clk2}$  is the ac-coupled zero-crossing point of the transmit clock's edge that latches out the second data edge being measured. To avoid introducing the effects of transmitter duty cycle distortion into this measurement,  $T_{diffmax}$  is calculated only with pairs of  $TR1$  and  $TR2$  measurements made either on the rising edges of data only or on the falling edges of data only.  $T_{diffmax}$  shall be calculated for both rising and falling edges.

$T_{diffmax}$  shall meet the following specification:

- a) at 4 Mbit/s  $-2.0 \text{ ns} < T_{diffmax} < 2.0 \text{ ns}$
- b) at 16 Mbit/s  $-2.0 \text{ ns} < T_{diffmax} < 2.0 \text{ ns}$

#### 7.2.2.2.2 Waveform pulse shape

For a data stream consisting of  $Data\_zero$  symbols, the voltage waveform for positive and negative pulses shall meet the template described in figure 33 and table 18 (16 Mbit/s) or figure 36 and table 21 (4 Mbit/s). For comparison to the template, time 0% is the time of the ac-coupled zero-crossing at the start of the waveform; time 100% is the time of the ac-coupled zero-crossing at the end of the waveform. Both positive and negative pulses are normalized by  $V_{pp}/2$ . The amplitude  $V_{pp}$  is measured as the peak-to-peak amplitude of the fundamental sine wave component of the  $Data\_zero$  symbols waveform.

For a data stream consisting of  $Data\_one$  symbols, the voltage waveform for positive and negative pulses shall meet the template described in figure 34 and table 19 (16 Mbit/s) or figure 36 and table 22 (4 Mbit/s) when normalized by  $V_{pp}/2$  measured on the  $Data\_zero$  symbols waveform.

For a data stream consisting of a starting delimiter (SD) preceded by a minimum of 20  $Data\_zero$  symbols, the voltage waveform of the first pulse three data signal elements wide shall meet the template described in figure 35 and table 20 (16 Mbit/s) or figure 36 and table 23 (4 Mbit/s) when normalized by  $V_{pp}/2$  measured on the  $Data\_zero$  symbols waveform.

In the following waveform pulse shape templates, (figures 33 through 36 and tables 18 through 23), the times are relative to the zero-crossing point at the start of the waveform and are scaled relative to the time between the zero-crossing point at the start of the waveform and the zero-crossing point at the end of the waveform. Measured waveforms should be normalized by  $V_{pp}/2$  for comparison to the template. The template consists of the space between the two piecewise linear curves connecting the above sets of data points.

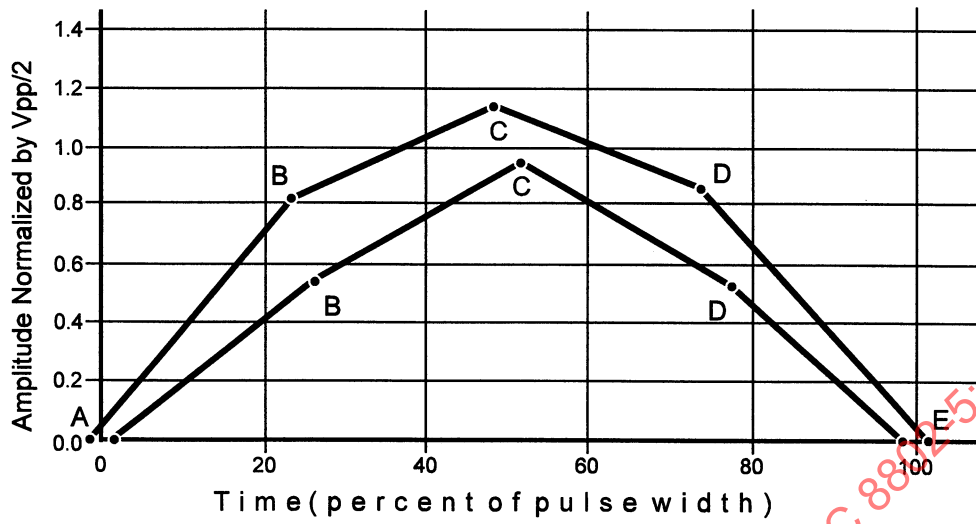

NOTE—See table 18 for point coordinates.

Figure 33—16 Mbit/s template for Data\_zero symbols waveform

Table 18—16 Mbit/s Data\_zero symbols template

Point	Upper time (%)	Upper amplitude	Lower time (%)	Lower amplitude
A	-1.5	0	1.5	0
B	23.5	0.83	26	0.55
C	48.5	1.15	51.5	0.95
D	73.5	0.862	77.5	0.52
E	101.5	0	98.5	0

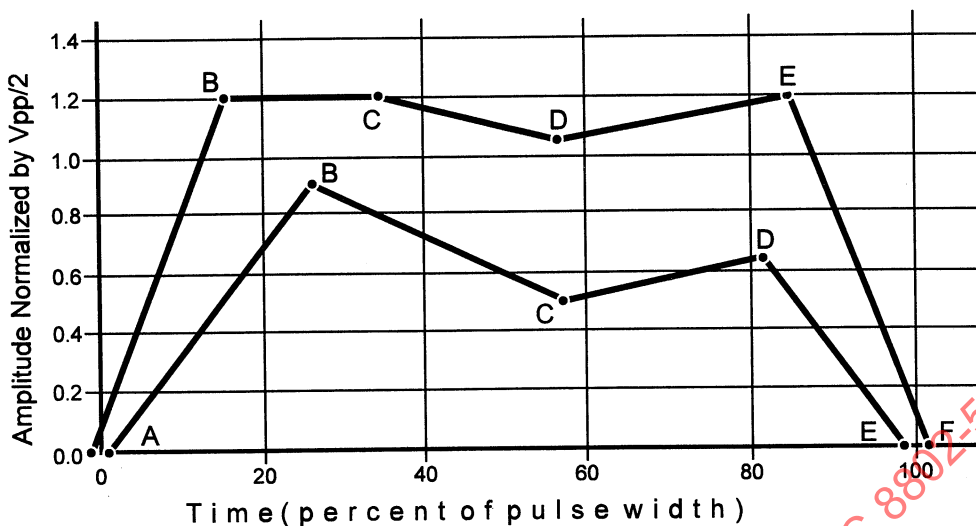

NOTE—See table 19 for point coordinates.

Figure 34—16 Mbit/s template for Data\_one symbols waveform

Table 19—16 Mbit/s Data\_one symbols template

Point	Upper time (%)	Upper amplitude	Lower time (%)	Lower amplitude
A	-1	0	1	0
B	15.5	1.2	26	0.9
C	34.5	1.2	57	0.5
D	56.5	1.05	81.5	0.65
E	85	1.2	99	0
F	101	0	—	—

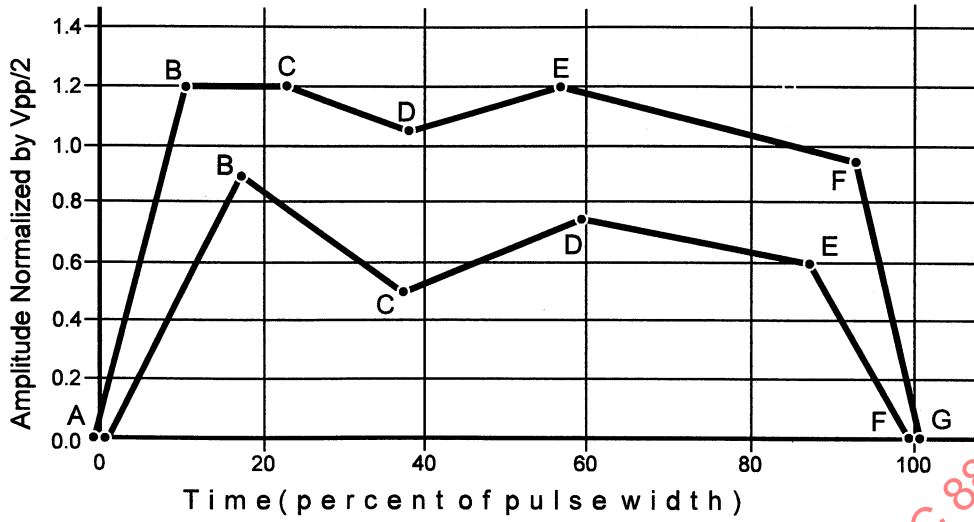

NOTE—See table 20 for point coordinates.

Figure 35—16 Mbit/s template for SD waveform

Table 20—16 Mbit/s SD template

Point	Upper time (%)	Upper amplitude	Lower time (%)	Lower amplitude
A	-0.5	0	0.5	0
B	10.5	1.2	17.5	0.9
C	23	1.2	37.5	0.5
D	38	1.05	59.5	0.75
E	57	1.2	87.5	0.6
F	93	0.95	99.5	0
G	100.5	0	—	—

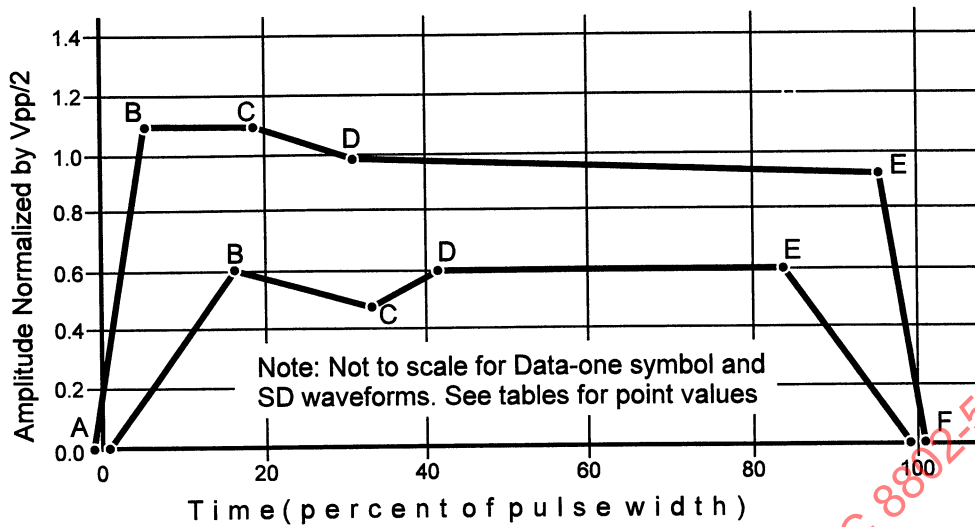

NOTE—See tables 21 through 23 for respective point coordinates.

Figure 36—4 Mbit/s template for Data\_zero symbol, Data\_one symbol, and SD waveforms

Table 21—4 Mbit/s Data\_zero symbols template

Point	Upper time (%)	Upper amplitude	Lower time (%)	Lower amplitude
A	-1	0	1	0
B	5.5	1.10	16.5	0.6
C	19	1.10	33.5	0.48
D	31	0.98	41.5	0.6
E	93.5	0.92	84	0.6
F	101	0	99	0

Table 22—4 Mbit/s Data\_one symbols template

Point	Upper time (%)	Upper amplitude	Lower time (%)	Lower amplitude
A	-0.5	0	0.5	0
B	2.5	1.10	8	0.6
C	10	1.10	16.5	0.52
D	15.5	0.98	22.5	0.64
E	100	0.88	90	0.68
F	100.5	0	99.5	0

Table 23—4 Mbit/s SD template

Point	Upper time (%)	Upper amplitude	Lower time (%)	Lower amplitude
A	-0.5	0	0.5	0
B	2	1.10	5.5	0.6
C	6.5	1.10	11	0.52
D	10.5	0.98	15	0.64
E	98.5	0.84	93.5	0.68
F	100.5	0	99.5	0

### 7.2.2.3 Differential output voltage

The measured value of the differential output voltage  $V_{pp}$  at TX-A and TX-B, as defined in 7.2.2.2, shall meet the specification for transmitter differential output voltage (TDOV) shown in table 24.

**Table 24—Transmitter differential output voltage specifications**

Cable type	4 Mbit/s	16 Mbit/s
TDCD (STP 150 $\Omega$ load)	3.0 – 4.5 V	3.0 – 4.5 V
TDCD (UTP 100 $\Omega$ load)	2.7 – 3.6 V	2.7 – 3.4 V

### 7.2.2.4 Transmitter return loss

The transmitter return loss (TXRL), which limits the differential reflected signal due to a differential signal incident upon the transmitter, is specified at the transmitter output TX-A and TX-B. The transmitter, which shall be powered up and transmitting any valid data pattern, shall provide a minimum TXRL, relative to a reference impedance of 150  $\Omega$  (STP) or 100  $\Omega$  (UTP), as shown in table 25.

**Table 25—Transmitter return loss specifications**

Ring speed	Frequency range	Minimum TXRL
4 Mbit/s	1 MHz to 6 MHz	14 dB
4 Mbit/s	6 MHz to 12 MHz	12 dB
16 Mbit/s	1 MHz to 6 MHz	14 dB
16 Mbit/s	6 MHz to 17 MHz	12 dB
16 Mbit/s	17 MHz to 25 MHz	8 dB

The differential signal incident upon the transmitter shall be a minimum of 0.5 V peak-to-peak ( $V_i$ ) when measuring the return loss.

The TXRL can be defined in terms of a differential reflected voltage or transmitter impedance as:

$$\text{TXRL} = 20 \log \left| \frac{Z_t + Z_{\text{ref}}}{Z_t - Z_{\text{ref}}} \right| = 20 \log \left| \frac{V_i}{V_r} \right|$$

where:

$Z_t$  is the impedance of the transmitter

$Z_{\text{ref}}$  is the reference impedance (150  $\Omega$  STP, 100  $\Omega$  UTP)

$V_i$  is the differential voltage incident upon the transmitter

$V_r$  is the differential voltage reflected from the transmitter

### 7.2.3 Receiver specifications

The PMC shall provide a receiver in accordance with the electrical specifications of this clause. The receiver includes all circuitry from the receive ports RX-A and RX-B to the transfer of data and timing information to the physical signaling symbol decoder and repeat path defined in figure 26. The receiver specifications are defined by the receiver jitter tolerance (7.2.3.1) and the receiver return loss (7.2.3.2).

#### 7.2.3.1 Receiver jitter tolerance

Jitter tolerance (JTOL) is the ability of a receiver to receive frame data at a data rate that has a static frequency error caused by clocking source tolerances and a time-varying frequency error caused by accumulated jitter. Jitter tolerance is specified here for two types of test channels<sup>17</sup>:

- a) A test channel (Test\_Chan\_B) containing attenuation proportional to the square root of the frequency and flat attenuation with no added noise for the JTOL measurement.
- b) A test channel (Test\_Chan\_C) containing attenuation proportional to the square root of the frequency and flat attenuation with added high-frequency noise designed to simulate the eye closure caused by high frequency disturbances such as that caused by crosstalk for the JTOLX measurement.

These test channels are defined in 7.2.4.4. Interoperability requires that the jitter tolerance exceed the specifications in table 26. JTOL is measured for a PMC receiving frames 1250 octets long containing worst-case data patterns from an active monitor station with a conformant transmitter whose clock source has both a static and a modulated frequency error.

JTOL and JTOLX are measured by using a signal from a transmitter clocked by a controlled clock source with a static frequency error of up to  $\pm 0.01\%$  and a time-varying frequency error of variable amplitude. The time-varying frequency error is zero-mean square wave modulated at a modulation frequency of FM. The amplitude (peak) of the square wave modulation of the clock source (in ns/ns) is increased until the frame error rate exceeds  $10^{-5}$ . The amplitude (peak) at which this occurs is the value of JTOL or JTOLX. JTOL and JTOLX shall meet the specifications shown in table 26 under the specified transmitter differential output voltages under any channel conformant with the test channel specifications referenced above and with worst-case static frequency error.

**Table 26—Receiver jitter tolerance specifications**

Parameter	4 Mbit/s	16 Mbit/s
$V_{pp}$ (STP)	3.6–3.8 V	3.6–3.8 V
$V_{pp}$ (UTP)	2.9–3.1 V	2.9–3.1 V
FM	4.67 kHz	9.17 kHz
JTOL	> 0.007 ns/ns	> 0.0172 ns/ns
JTOLX	> 0.0035 ns/ns	> 0.0082 ns/ns

<sup>17</sup> These test channels are defined in 7.2.4.4, table 32.

### 7.2.3.2 Receiver return loss

The receiver return loss (RRL), which limits the differential reflected signal due to a differential signal incident upon the receiver, is specified at the receiver input ports RX-A and RX-B of the MIC. The receiver shall provide a minimum RRL, relative to a reference impedance of 150  $\Omega$  (STP) or 100  $\Omega$  (UTP), as shown in table 27.

**Table 27—Receiver return loss specifications**

Ring speed	Frequency range	Minimum RRL
4 Mbit/s	1 MHz to 12 MHz	15 dB
16 Mbit/s	1 MHz to 17 MHz	15 dB
16 Mbit/s	17 MHz to 25 MHz	8 dB

The RRL can be defined in terms of a differential reflected voltage or receiver impedance as

$$\text{RRL} = 20 \log \left| \frac{Z_r + Z_{\text{ref}}}{Z_r - Z_{\text{ref}}} \right| = 20 \log \left| \frac{V_i}{V_r} \right|$$

where

- $Z_r$  is the impedance of the receiver
- $Z_{\text{ref}}$  is the reference impedance (150  $\Omega$  STP, 100  $\Omega$  UTP)
- $V_i$  is the differential voltage incident upon the receiver
- $V_r$  is the differential voltage reflected from the receiver

### 7.2.4 Channel specifications for copper cabling

This clause provides the specifications for two types of channels for connecting conforming devices (stations, concentrators, repeaters, etc.) that will allow the devices to perform as specified in 7.1 and 7.2.3. The two channel types are a passive channel for use with passive concentrators (8.4) and an active channel for use with active concentrators (8.5).

Channel attenuation (7.2.4.2.1), signal-to-crosstalk noise (7.2.4.3.1), and channel impedances (7.2.4.2.2) are specified for both the passive and active channels. These specifications support devices operating exclusively at 4 Mbits/s data rate (only 4 Mbits/s), and devices that can operate at either a 4 or 16 Mbits/s or only 16 Mbits/s data rate (16/4 Mbits/s).

The passive and active channel specifications provide the basis for the test channels specified in 7.2.4.4 and the channel design guidelines in annex B.

#### 7.2.4.1 Channel types

In order to provide channel specifications that permit stations to operate with both passive (8.4) and active (8.5) concentrators, both a passive and active channel are defined.

### 7.2.4.1.1 Passive channel

The passive channel is the transmission path between the MIC of a transmitting repeater or station and the MIC of the next receiving repeater or station, where the concentrator ports to which the stations are attached are passive. The passive channel, illustrated in figure 37, consists of all the components in the transmission path, which includes the lobe cables and cords, passive concentrator(s), and, where appropriate, the inter-concentrator trunk cable and connectors.

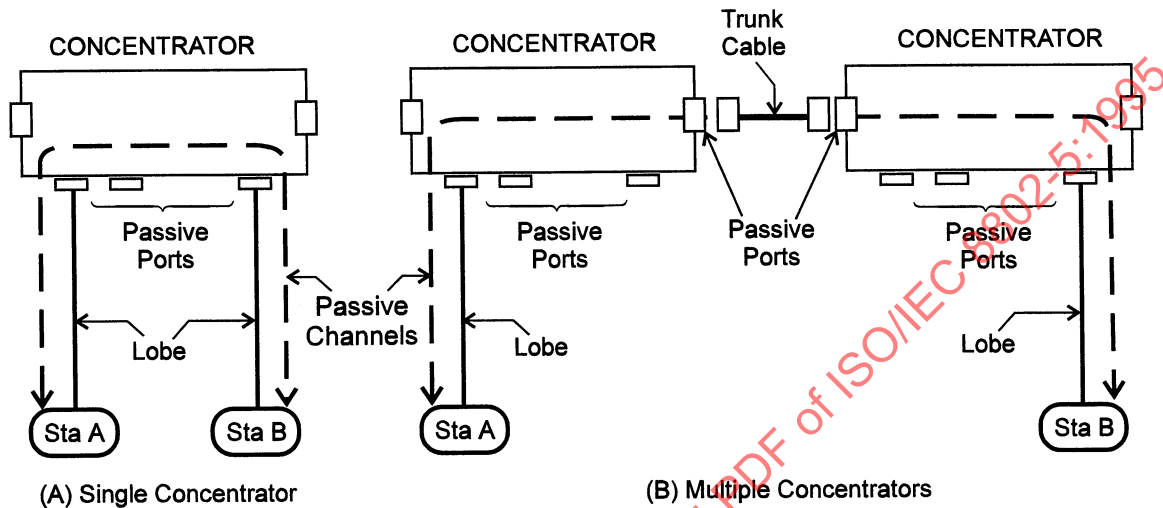

Figure 37—Passive channel<sup>18</sup>

### 7.2.4.1.2 Active channel

The active channel consists of all the components in the transmission path between the MIC of a station and the MIC of an active concentrator port or all of the components in the transmission path between the MIC of a concentrator ring out (RO) port that is active and the MIC of a concentrator ring in (RI) port that is active. The active channel is illustrated in figure 38.

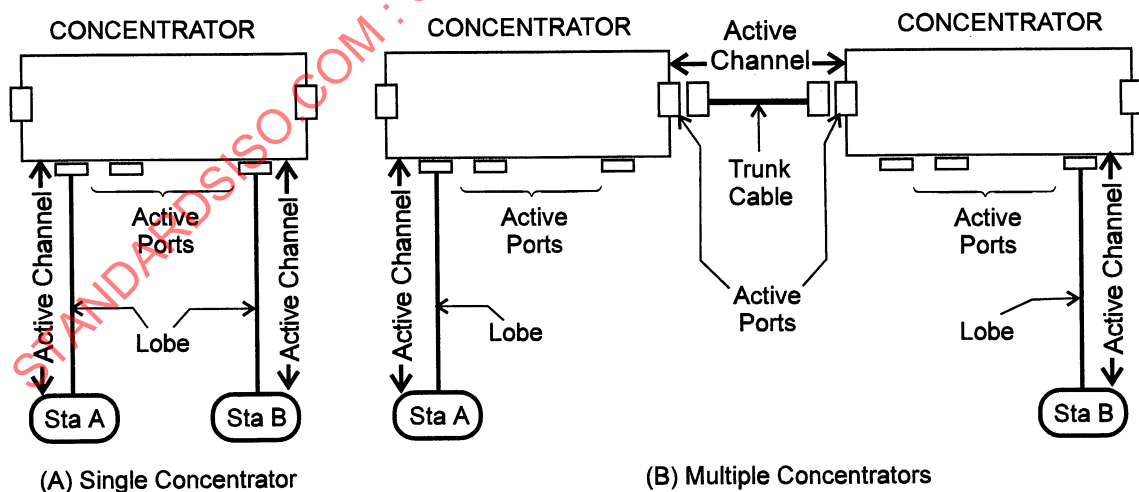

Figure 38—Active channel

<sup>18</sup> See figures B-2 and B-3 for channel design using backup path.

### 7.2.4.1.3 Channel implementation

The passive and active channels shall be implemented using copper shielded twisted pair (STP) cabling or copper unshielded twisted pair (UTP) cabling. STP and UTP shall meet the relevant clauses of ISO/IEC 11801 : 1995. For new installations utilizing STP, Type 1A cable is recommended. For new installations utilizing UTP, Category 5 is recommended. Each of the two channels includes all of the components in the transmission path between the MIC of the transmitting device and the MIC of the receiving device. These components include station cords, station wall outlet connectors, horizontal distribution cable, cross connect fields and associated jumper cords, concentrator patch cords, passive concentrators and inter-concentrator trunk cabling and connectors. This standard addresses both trunk and patch cables as specified in ISO/IEC 11801 : 1995. It is recommended that all UTP patch cords meet Category 5 specifications.

### 7.2.4.2 Transmission parameters

Two transmission parameters, attenuation and differential impedance, are specified for both the passive and active channels. Crosstalk is also an important characteristic for the channel. The allowed crosstalk for the channel as a whole is not specified directly, but is determined by the requirements for SCNR and NIR (see 7.2.4.3.1 and 7.2.4.3.2). Crosstalk for cables and components is specified in ISO/IEC 11801 : 1995; however, it is specified for individual components in the channel rather than for the channel as a whole.

#### 7.2.4.2.1 Channel attenuation

Channel attenuation consists of the attenuation of the channel cable pairs, connector losses, reflection losses due to impedance mismatches between the various components of the channel, and the passive concentrator loss as measured by insertion loss.

The channel attenuation of a passive channel consists of the loss of all the channel components between a station MIC and the MIC of the next downstream station. As shown in figure 37(A) for a single concentrator, the attenuation of the passive channel consists of the loss between the Station A MIC and the concentrator port MIC, plus the loss between the two concentrator ports (concentrator loss), plus the loss between the concentrator port MIC and the Station B MIC. For the multiple concentrator example of figure 37(B), the attenuation consists of the loss between the Station A MIC and the concentrator port MIC, plus the concentrator loss for the first concentrator, plus the loss of the trunk cable between the two concentrators, plus the loss of the second concentrator, plus the loss between the second concentrator port MIC and the Station B MIC (refer to annex B for further explanation of how to determine the maximum length channel loss).

The channel attenuation of an active channel consists of the loss between a station MIC and its respective active concentrator port MIC, or the loss between an active RO port MIC of one concentrator and the active RI port MIC of a second concentrator. As shown in figure 38(A) for a single concentrator, the channel attenuation of each of the two active channels consists of the loss between the station MIC and its respective active concentrator port MIC. Figure 38(B) shows multiple concentrators with three active channels. The channel attenuation of the two station-to-concentrator active channels consists of the loss between the station MIC and its respective concentrator port. The channel attenuation of the third active channel, which interconnects the two concentrators, consists of loss between the first concentrator RO MIC and the second concentrator RI MIC.

The maximum attenuation of each channel shall not exceed the losses in table 28. The losses shall be met when the channel type channel is terminated in  $100 \Omega \pm 1\%$  for UTP and  $150 \Omega \pm 1\%$  for STP.

**Table 28—Channel attenuation specifications**

Channel type	Channel attenuation	
	Only 4 Mbit/s	16/4 Mbit/s
Passive	< 19 dB @ 4 MHz	< 19 dB @ 16 MHz
Active	< 19 dB @ 4 MHz	< 16 dB @ 16 MHz

The passive and active channel attenuation consists primarily of cable loss whose attenuation in decibels and non-linear portion of the phase vary as the square root of frequency. In addition, the passive channel may contain flat loss, a component of attenuation that does not vary with frequency. The passive channel attenuation shown in table 28 shall consist of no more than 2 dB of flat loss for all data rates. Note that the maximum attenuation shown in table 28 applies for channels that just meet the SCNR requirements of table 30. Channels possessing higher SCNR may be able to support slightly higher attenuation. This is a subject for future study.

#### 7.2.4.2.2 Channel differential impedance

The magnitude of the channel differential input and output impedance, for both the passive and active channels, when using STP and UTP media, shall meet the specifications of table 29 when measured according to ASTM D4566-1994 [B1].

**Table 29—Channel differential impedance specifications**

Media type	Differential impedance	Frequency range	
		Only 4 Mbit/s	16/4 Mbit/s
UTP	$100 \pm 15 \Omega$	1–12 MHz	1–25 MHz <sup>19</sup>
STP	$150 \pm 15 \Omega$	1–12 MHz	1–25 MHz

All individual cables, cords, and components in the channel shall be of the same cable type and nominal impedance and shall meet the specifications of table 29 in order to minimize distortion due to reflections at impedance discontinuities.

The impedance ranges specified in table 29 are limits on the nominal characteristic impedance of the media, and are not indicative of the allowable variation in characteristic impedance within a section or within any channel. In addition, it is recommended that in order to limit the impedance variations within a channel, each permanently installed cabling run between telecommunications closets and between a telecommunications closet and a wall outlet should consist of a single homogeneous cable run without splices or intermediate connectors. It is recommended that the return loss of the cabling meet the return loss specified for the class C link in ISO/IEC 11801 : 1995.

<sup>19</sup> Category 3 is only specified to 16 MHz but it is assumed that it can be extrapolated to 25 MHz.

### 7.2.4.3 Noise environment

The level of noise in the passive and active channels must be limited to ensure the system error rate stated in 7.0 is provided. The noise environment associated with the passive and active channels consists primarily of two contributors: (1) crosstalk noise due to signals within the transmission components, and (2) noise induced into the channels from sources external to the transmission components used to provide the channels. Crosstalk noise will be present in all channels and is minimized by using channel components with high crosstalk loss. The primary crosstalk noise in a channel is the result of the transmitter Manchester signals coupling into the receive channel, which appear at the input of a receiver along with the data signals. The level of the crosstalk noise in a channel depends on the level of the transmitter signal(s) and the crosstalk loss between the cable pair(s) carrying the transmitter signal(s) and the cable pair assigned to the receiver.

Channel crosstalk noise specifications are based on the use of a sheathed cable carrying token ring signals for a single station. The sharing of the sheath with other services is beyond the scope of this part of ISO/IEC 8802. While the use of multi-pair cables to carry multiple services is not addressed here, the following guidance is provided.

The result of the total crosstalk noise from all disturbers in a multi-pair sheathed cable should not exceed the specifications of the SCNR of 7.2.4.3.1. For example, sharing of services with analog telecommunications devices may result in unacceptable levels of crosstalk noise.

For guidance on external noise limits and cabling recommendations, see 7.2.4.3.3 and ISO/IEC 11801 : 1995.

#### 7.2.4.3.1 Signal-to-crosstalk noise ratio (SCNR)

To ensure the receiver of 7.2.3 will operate properly in the presence of crosstalk noise generated by the Manchester transmitter signals of 7.2.2, the passive and active channels shall provide the minimum peak SCNR at the channel output shown in table 30 for sinusoidal signals at the data rate.

**Table 30—Channel SCNR specifications**

Channel type	SCNR	
	Only 4 Mbit/s	16/4 Mbit/s
Passive	> 15.5 dB	> 13.5 dB
Active	> 15.5 dB	> 12.0 dB

#### 7.2.4.3.2 NEXT loss to insertion loss ratio (NIR)

To meet the SCNR of 7.2.4.3.1 and take into account the transmitter output variation specified in 7.2.1 (3.5 dB for STP and 2 dB for UTP), the channel shall provide an NIR, meeting the specifications in table 31. NIR is defined as the ratio of the minimum Adjusted NEXT Loss over a frequency range to the insertion loss at the reference frequency  $F_{ref}$ . For 16/4 and 16 Mbit/s operation, the frequency range is 1–25 MHz and  $F_{ref}$  is 16 MHz. For 4 Mbit/s operation, the frequency range is 1–12 MHz and  $F_{ref}$  is 4 MHz. The Adjusted NEXT Loss<sup>20</sup> is defined as the NEXT loss of the channel in dB (at a frequency  $F$ ) plus  $15\log(F/F_{ref})$ . The complex distributed nature of the couplings between pairs in cables typically causes channel crosstalk loss characteristics to vary rapidly with frequency. Hence, it is inadequate to characterize

<sup>20</sup> Although this adjustment is based on the characteristics of cables (see ISO/IEC 11801 : 1995), it is intentionally used here to specify a limit on the characteristics of the entire channel.

the crosstalk loss at a single frequency; therefore, NEXT loss is measured over a frequency band. Figures 39, 40, and 41 show the relationship between channel Adjusted NEXT Loss and insertion loss at  $F_{ref}$ .

**Table 31—Channel NEXT loss to insertion loss ratio (NIR) specifications**

Channel	Channel NEXT Loss to NIR			
	Only 4 Mbit/s		16/4 Mbit/s	
	STP	UTP	STP	UTP
Passive	> 19.0 dB	> 17.5 dB	> 17.0 dB	> 15.5 dB
Active	> 19.0 dB	> 17.5 dB	> 15.5 dB	> 14.0 dB

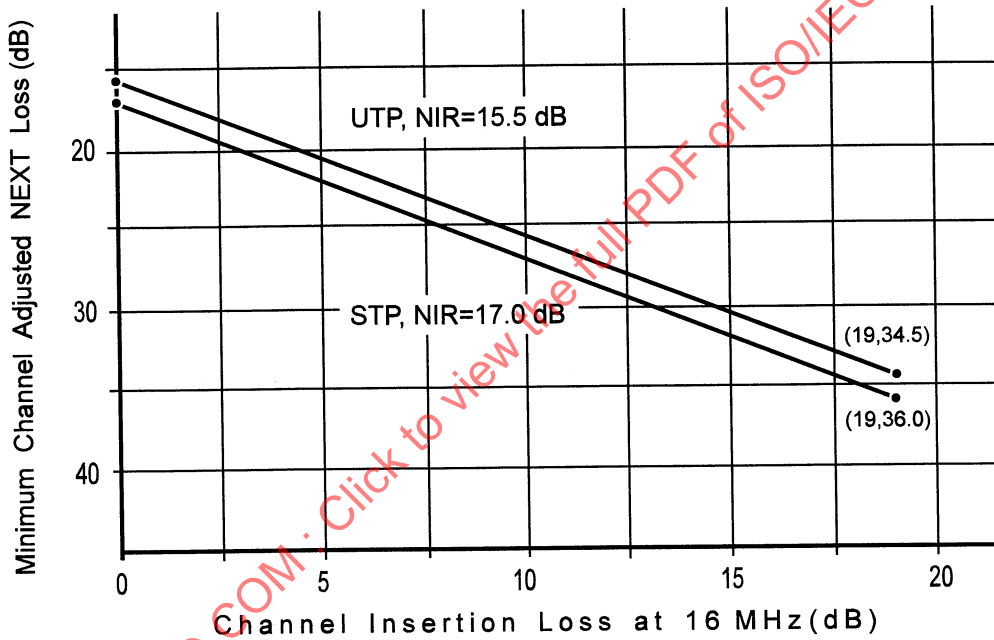

**Figure 39—Minimum Adjusted NEXT Loss vs channel insertion loss to meet 16/4 Mbit/s passive channel NIR**

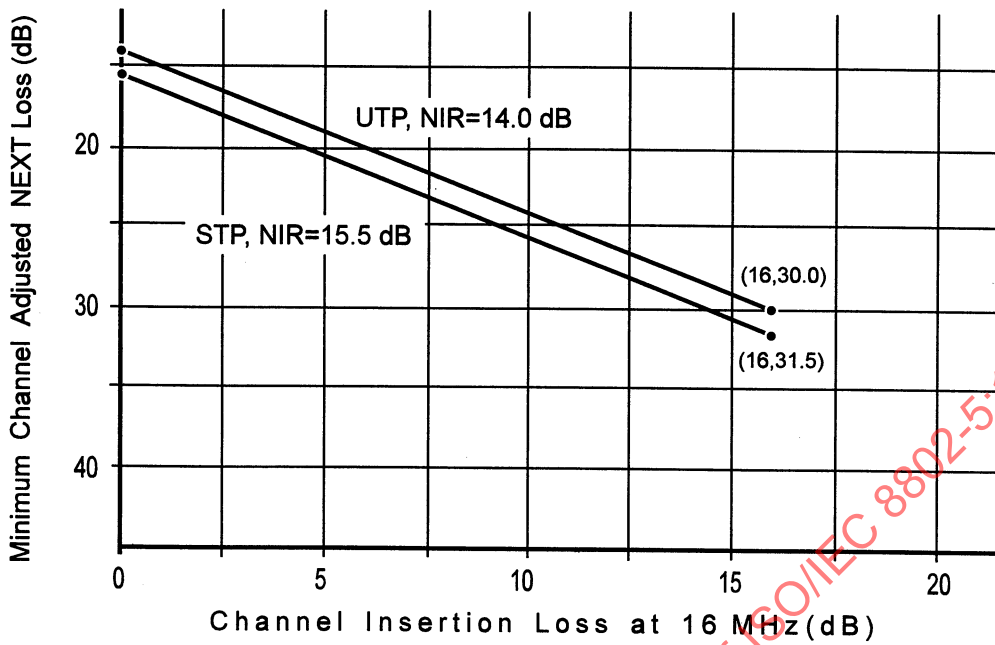

Figure 40—Minimum Adjusted NEXT Loss vs channel insertion loss to meet 16/4 Mbit/s active channel NIR

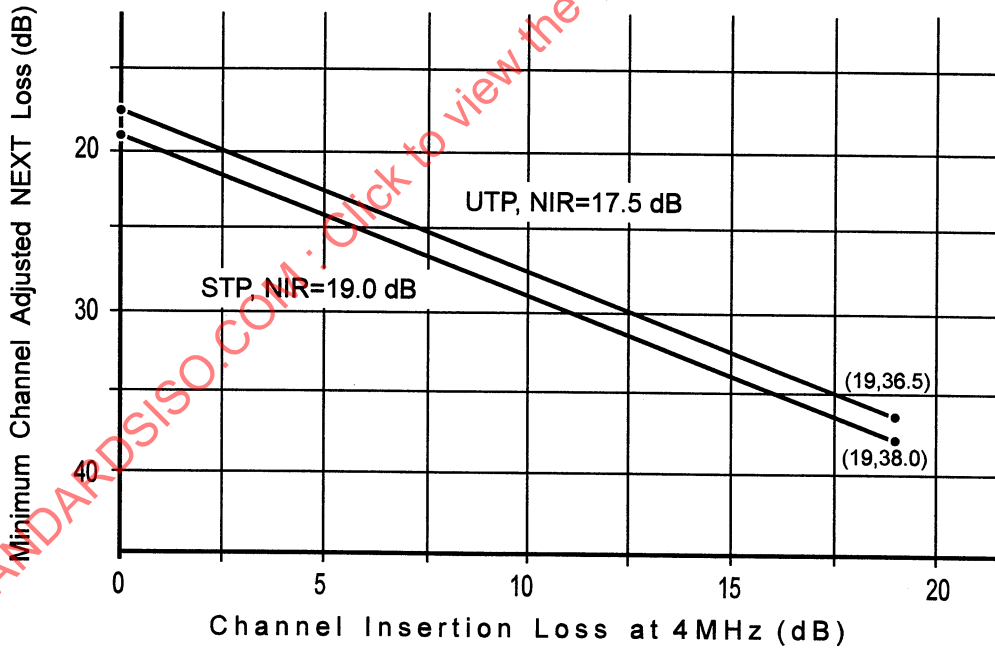

Figure 41—Minimum Adjusted NEXT Loss vs channel insertion loss to meet 4 Mbit/s only passive and active channel NIRs

### 7.2.4.3.3 External noise recommendations

System characterization of noise from sources external to the channel (i.e., all noise except crosstalk noise) and its impact on the system error rate is a subject for future study. External noise coupling into a channel is dependent on the type of cabling system, cabling environment, and the station and concentrator hardware implementation. The following is a conservative recommendation for externally generated noise for both passive and active channels. The effects of external noise can be neglected when the peak noise at the input to the station receiver is at least 30 dB below the peak level of the data signal. For the minimum transmitter signal level specified in 7.2.2 and the maximum channel attenuation of 7.2.4.2.1, the effects of external noise can be neglected as long as the peak external noise is within the shaded region of figure 42 for STP and UTP. If external noise is outside the shaded region of figure 42, it should not be ignored. In such environments special precautions, such as increasing the minimum acceptable NIR to budget for the effects of external noise, may be warranted to assure that the system error rate is not compromised. Specific recommendations for high external noise environments are beyond the scope of this standard. External noise can be kept within acceptable limits in all applicable environments by the proper choice and installation of the cabling system. STP and UTP Category 5 cables are extremely effective in limiting system errors due to external noise. UTP Category 4 cable is somewhat less effective, and UTP Category 3 is the least effective UTP cable, or most susceptible to coupling external noise signals into the channel. For very high external noise environments, 150  $\Omega$  STP cable may be required. For most installations, external noise presents no problem when any of these cable systems are used.

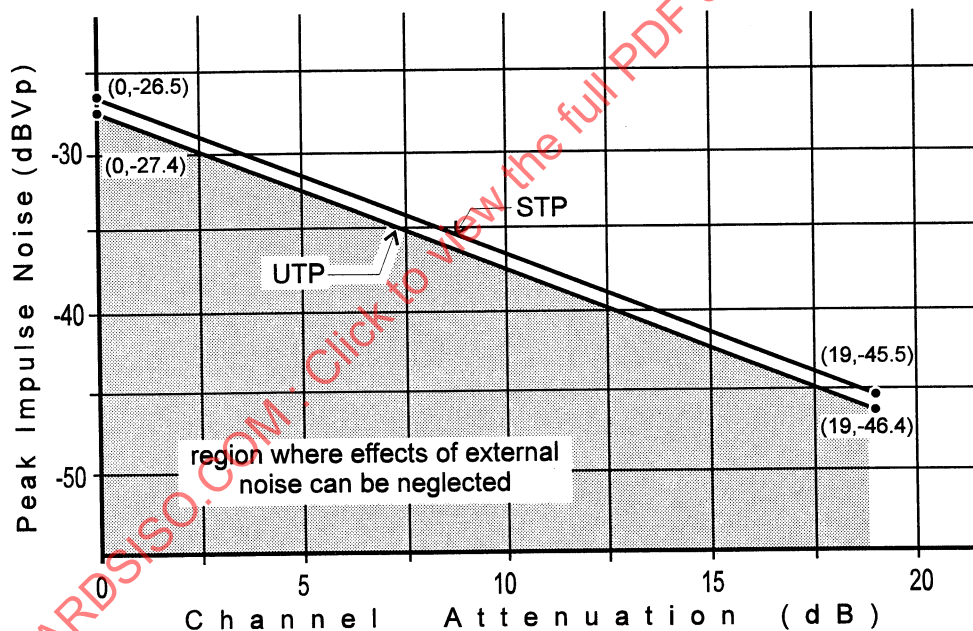

Figure 42—Impulse noise level recommendations for passive and active channels

### 7.2.4.4 Test channels

Test channels are used to allow the specification of various performance parameters (AJ, FAPS, DFAPS, JTOL, JTOLX) of the PHY under controlled conditions. The generic test channel is a channel containing only attenuation proportional to the square root of frequency and attenuation that is flat across frequency. The total channel attenuation of the test channel may be any value less than TCATT. For active channels this channel attenuation shall be composed entirely of root-frequency attenuation and no flat loss. For passive channels, the total channel attenuation may consist of root-frequency attenuation and up to 2 dB of flat loss. The channel should have minimal crosstalk; however, noise that simulates crosstalk or other noise

sources may be added to the channel in a controlled fashion as specified in the next paragraph. The impedance of the test channel shall be within the range from 145–155  $\Omega$  for an STP channel and from 95–105  $\Omega$  for a UTP channel.

For test channels that include added noise, an external source is used to inject a sinusoidal noise at a frequency  $F_n$  into the channel in a manner that causes minimal interference in the characteristics of the channel except for the noise injected. The amplitude of the interference is adjusted to establish a *signal-to-interference* ratio of SIR dB at the MIC RX-A and RX-B. The *signal* level is the peak-to-peak amplitude of the fundamental sine wave component of the zeros pattern waveform and the *interference* level is the peak-to-peak amplitude of the sinusoidal noise signal.

Table 32 specifies the values of these parameters for each test channel. These test channels are used in the specifications in 7.1.1 and 7.2.3.1.

**Table 32—Test channel specifications**

Data rate	Parameter	Test_Cha_A (AJ, FAPS, DFAPS)	Test_Chan_B (JTOL)	Test_Chan_C (JTOLX)
4 Mbit/s	TCATT	13 dB	19 dB	19 dB
	$F_n$	—	—	3 MHz
	SIR	—	—	12 dB
16 Mbit/s	TCATT	19(13) dB	19(16) dB	19(16) dB
	$F_n$	—	—	12 MHz
	SIR	—	—	12(12) dB

Note that active concentrator PHYs are only tested up to TCATT and SIR conditions shown in parentheses. The channel attenuations for 4 and 16 Mbit/s are referenced to the frequencies 4 and 16 MHz respectively. Test\_Chan\_A TCATT is lower than that of B and C to allow simpler and less expensive equalizer design at 4 Mbit/s. Since accumulated jitter is the sum of the jitter introduced by all the PHYs in the ring, advantage can be taken of the typical distributions of channel attenuations that result in most of the channels having attenuations well below 13 dB. The presence of a few channels with higher jitter will not substantially affect the accumulated jitter. The same approach cannot be taken with jitter tolerance (test channels B and C) since the presence of even one PHY with poor jitter tolerance can cause errors in the ring.

## 7.2.5 Medium-dependent interface specifications

This clause defines the station medium-dependent interface MIC\_S and MIC\_U for attaching the station to STP and UTP media, respectively. The manufacturer is responsible for defining the location of the MIC on the manufacturer's device and cable. Possibilities include defining the MIC at the device card edge or at the end of a patch cord that attaches to the device. In all cases, the connector shall meet the mechanical specifications given in the following subclauses.

### 7.2.5.1 MIC\_S (STP medium interface connector)

Hermaphroditic connectors meeting the mechanical specifications in the following clauses shall be used as the mechanical interface between the PMC and the STP channel. It is recommended that the connectors also meet the electrical characteristics specified in 7.2.5.1.2.

### 7.2.5.1.1 MIC\_S mechanical specifications

Figure 43 shows an isometric view of the medium interface connector as it would be oriented when it is wall-mounted. It has four signal contacts with a ground contact and is hermaphroditic in design so that two identical units will mate when oriented 180 degrees with respect to each other.

### 7.2.5.1.2 MIC\_S mechanical characteristics

- |                                                       |                                           |
|-------------------------------------------------------|-------------------------------------------|
| a) Contact force                                      | 0.5–1.0 N                                 |
| b) Minimum insertions without a failure               | > 500                                     |
| c) Surface treatment (compatible with the following): |                                           |
| 1) Point-of-pin contact                               | plating with 3 $\mu\text{m}$ of hard gold |
| 2) Point-of-shield contact                            | plating with 5 $\mu\text{m}$ of tin       |

The mechanical mateability of the connector is subject to standardization by IEC.

### 7.2.5.1.3 MIC\_S electrical characteristics

It is recommended that the MIC\_S meet the specifications in ISO/IEC 11801 : 1995.

### 7.2.5.1.4 MIC\_S medium interface connector—contact detail

Figure 44 shows the details of the signal and ground contacts. When the connector is disconnected, pin R shall be shorted to pin O and pin G shorted to pin B for automatic looping capability. Only those dimensions that are essential to mating are shown.

### 7.2.5.1.5 MIC\_S medium interface connector—locking mechanism detail

Figure 45 shows the locking mechanism of the connector. Only those dimensions that are essential to mating are shown.

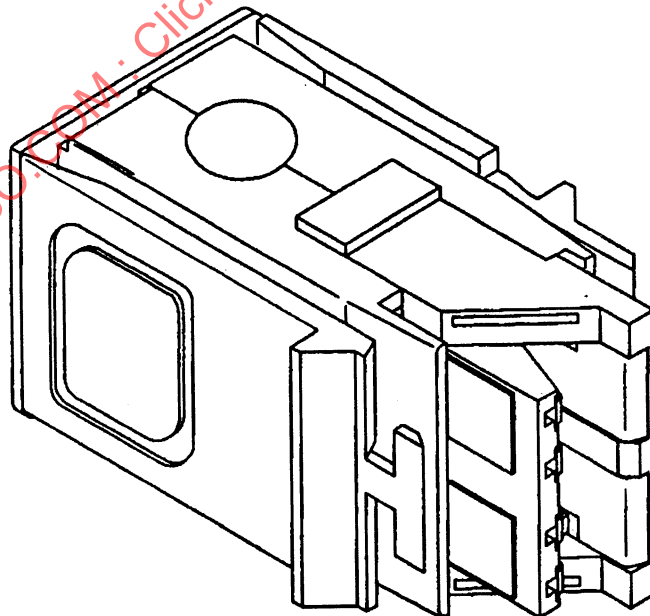

Figure 43—MIC\_S—isometric view

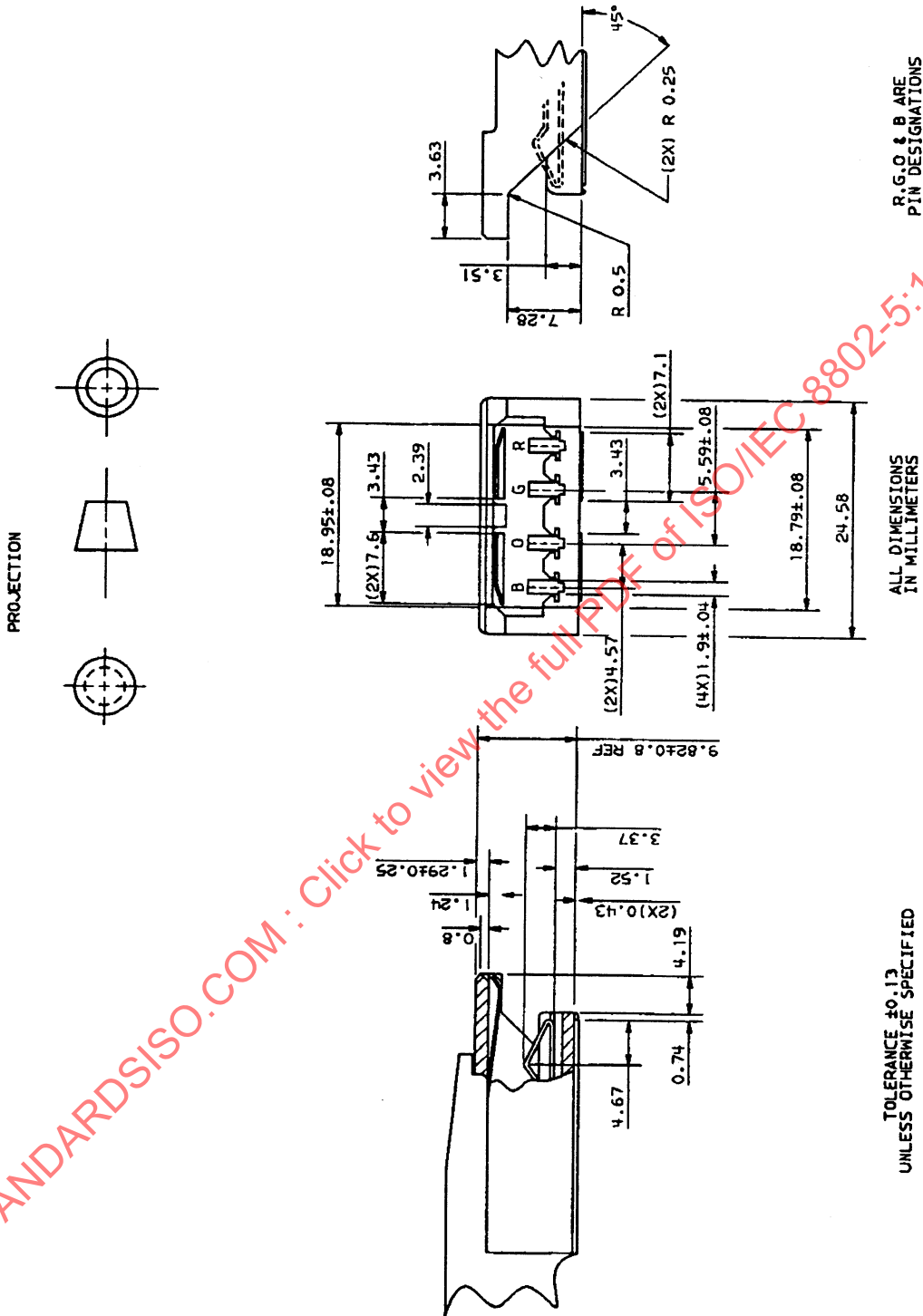

Figure 44—MIC\_S—contact detail

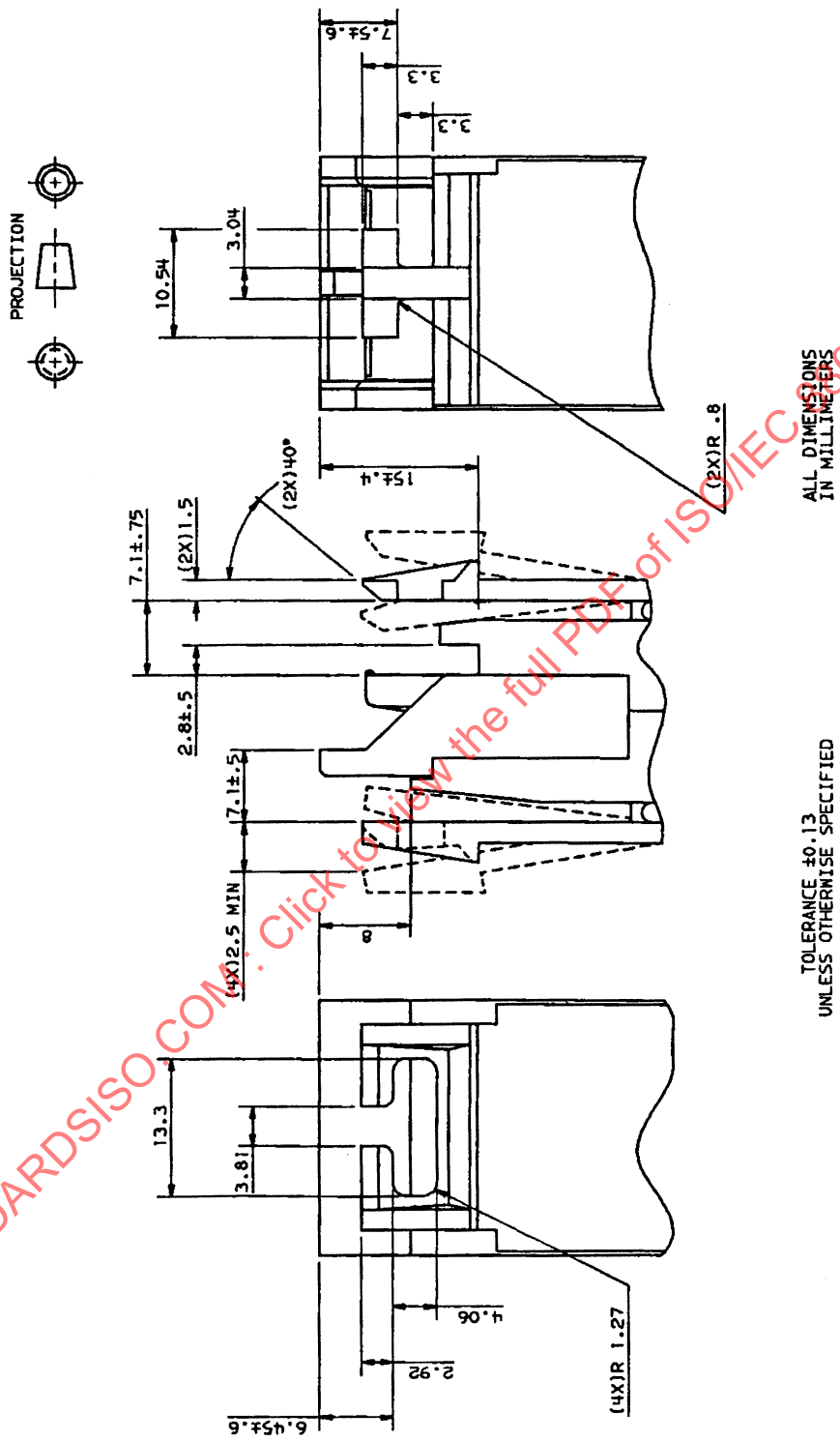

Figure 45—MIC\_S—locking mechanism detail

### 7.2.5.2 MIC\_U (UTP medium interface connection)

Either shielded or unshielded eight-pin connectors meeting the mechanical specifications in the following clause shall be used as the mechanical interface between the PMC and the UTP channel.

#### 7.2.5.2.1 MIC\_U mechanical specifications

The eight-pin connectors shall meet the mechanical specifications of IEC 603-7 : 1990. Either the plug or jack form of the connector may be used.<sup>21</sup> The plug and jack are illustrated in figure 46.

Unlike the STP connector, the UTP connector is not self-shorting. Other means of ensuring ring integrity in the event of an unplugged cable are necessary.

#### 7.2.5.2.2 MIC\_U electrical characteristics

It is recommended that the MIC\_U meet the Category 5 electrical specifications defined in ISO/IEC 11801 : 1995.

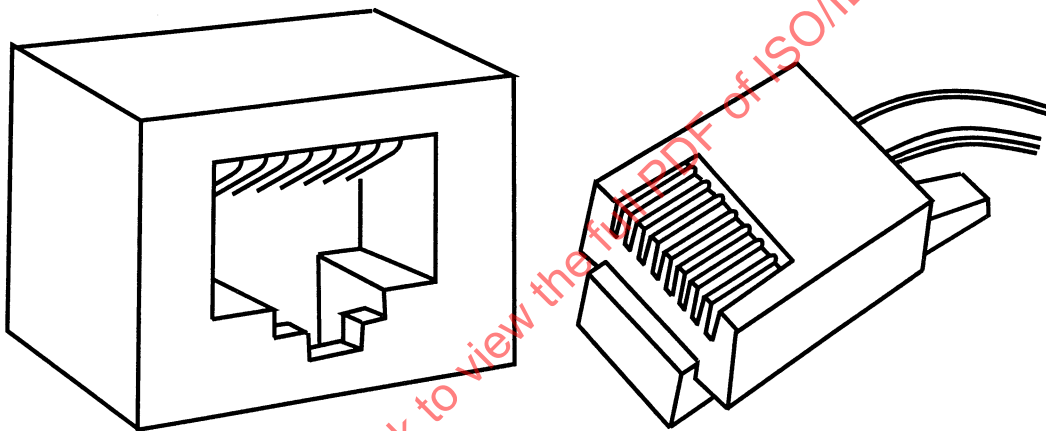

Figure 46—Illustration of MIC\_U jack and plug

<sup>21</sup> For purposes of conformance testing, the jack form of the connector shall be used.

## 8. Concentrator specifications

This clause defines the electrical, mechanical, and functional specifications for token ring concentrators. Two types of concentrators are specified, a passive concentrator and an active retiming concentrator. Both concentrator types provide the following functions:

- a) Into a ring couple stations attached to lobe cabling to the ring trunk.
- b) Interconnect multiple trunk coupling units (TCUs) to form a concentrator to support a star-wired network topology.
- c) Support message traffic at data signaling rate of 4 or 16 Mbit/s.
- d) Provide for station confirmation of TCU presence and support of station detection of an open wire condition and certain short-circuit conditions in the lobe cabling.
- e) May include ring in and ring out trunk attachments for serial connection of multiple concentrators topology over the trunk cable.

The need for specifying two types of concentrators, passive and active retiming, is due to the relationship between the ring speed and the cabling plant. The passive concentrator is a simple device aimed at installations where repeating elements are not required to support channel drive distance. In the case of the passive concentrator, the channel losses include, at a minimum, the two-directional lobe cabling loss, plus the concentrator loss, plus the losses of any additional passive devices in the channel. The active concentrator performs an imbedded repeater function in the lobe port's data path thereby providing ring segment boundaries at the concentrator lobe port connector (CMIC). Refer to figures 37 and 38 for examples of passive and active channels, respectively. Additional information relative to the relationship that exists between the cabling plant, the ring speed, and the type of concentrator is given in the annex B.

Refer to annex E for recommendations relative to telephony voltages and network safety.

### 8.1 Concentrator lobe port

The concentrator shall provide a connector (CMIC) to connect a lobe cable from a station to the associated TCU. Two types of connectors are defined; the CMIC\_S connector for attaching STP lobe cabling and the CMIC\_U connector for attaching UTP lobe cabling. This subclause also defines the transmission path between the concentrator CMIC and the station MIC.

#### 8.1.1 Concentrator lobe connector

The two types of concentrator lobe port connectors are as follows:

- a) The CMIC\_U connector, used for attaching UTP lobe cabling, shall meet the required specifications for the jack form of the connector in 7.2.5.2.
- b) The CMIC\_S connector, used for attaching STP lobe cabling, shall meet the required specifications of 7.2.5.1. Table 33 shows the signal and contact assignments for the two connectors.

**Table 33—C\_MIC contact and signal assignments**

CMIC_U contact	CMIC_S contact	Concentrator signal
1	—	Not used by this standard
2	—	Not used by this standard
3	B	LRX-A
4	R	LTX-A
5	G	LTX-B
6	O	LRX-B
7	—	Not used by this standard
8	—	Not used by this standard

The interchange of LTX-A with LTX-B and the interchange of LRX-A with LRX-B will not affect functionality, and is permitted by this standard.

The concentrator receive signal ports (LRX) at the concentrator lobe port connector CMIC\_U or CMIC\_S are connected via the UTP or STP lobe cabling to the station transmit signal ports (TX) at the station's MIC\_U or MIC\_S. Similarly, the concentrator transmit signal ports (LTX) are connected to the station receive signal ports (RX). These connections are depicted in figure 47.

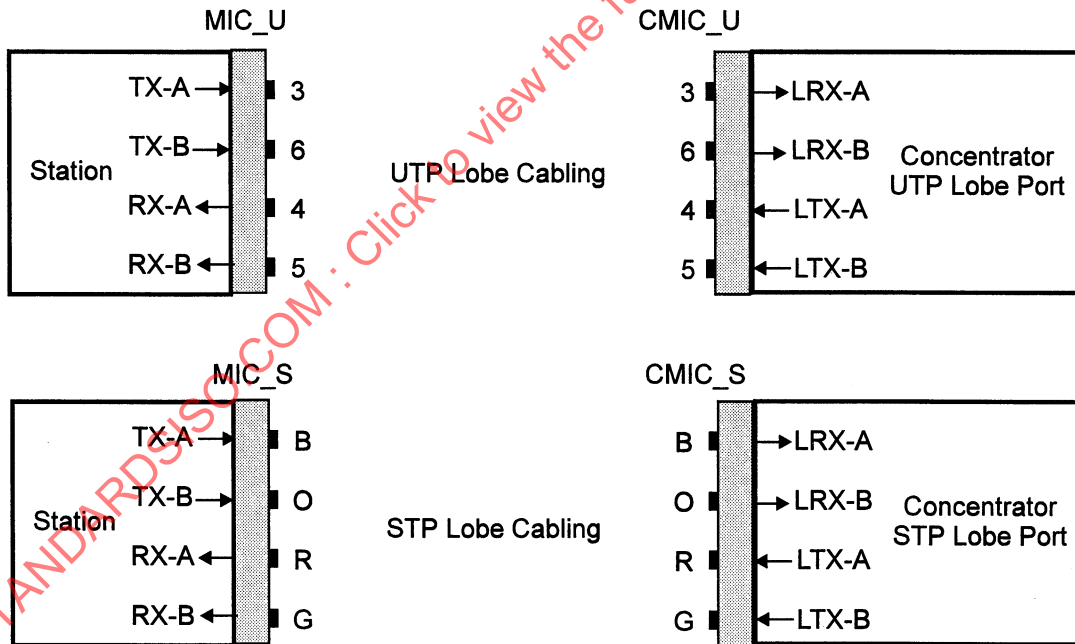

**Figure 47—Concentrator UTP and STP lobe connections**

**8.1.2 Concentrator lobe port indicators**

If a visible indicator(s) is provided on a concentrator to indicate the status of a port, it is recommended that the color be green and that the indicator be labeled appropriately. It is further recommended that the

indicator be ON when the port has detected phantom current and the attached station is inserted. Guidance for the color and meaning of displays is contained in IEC 73 : 1991.

## 8.2 Concentrator trunk ports

The concentrator may provide trunk port connections for attaching the concentrator to the trunk cable. The specifications of this clause are based on the assumption that trunk ports exist or that the appropriate internal connections are maintained. At the trunk ports, if alternate media attachment is provided, then these points must be ring segment boundaries. Trunk ports that are not ring segment boundaries will be referred to hereinafter as passive trunk ports. The connectors, referred to as *ring in MIC* (RIMIC) and *ring out MIC* (ROMIC), permit concentrators to be cascaded to expand the size of a ring; RO of one concentrator is connected to RI of the next concentrator. Two connectors are specified for each type: RIMIC\_S and ROMIC\_S for use with STP media, and RIMIC\_U and ROMIC\_U for use with Category 5 UTP media. Also, the main ring transmission path and the back-up transmission path through the concentrator are defined.

### 8.2.1 Concentrator trunk connector

Two concentrator trunk port connectors, if provided, for attaching the concentrator to the trunk cable, shall be as follows:

- a) The RIMIC\_S and ROMIC\_S connectors, used for attaching STP trunk cabling, shall meet the required specifications for the connector in 7.2.5.1.
- b) The RIMIC\_U and ROMIC\_U connectors, used for attaching UTP trunk cabling, shall meet the required specifications for the jack form of the connector in 7.2.5.2. Table 34 shows the signal and contact assignments for the four connectors.

**Table 34—U\_MIC contact and signal assignments**

ROMIC_U/ RIMIC_U contact	ROMIC_S/ RIMIC_S contact	RIMIC signal	ROMIC signal
1	—	Not used by this part of ISO/IEC 8802	
2	—	Not used by this part of ISO/IEC 8802	
3	B	TXBACKUP-A	RXBACKUP-A
4	R	RXMAIN-A	TXMAIN-A
5	G	RXMAIN-B	TXMAIN-B
6	0	TXBACKUP-B	RXBACKUP-B
7	—	Not used by this part of ISO/IEC 8802	
8	—	Not used by this part of ISO/IEC 8802	

The interchange of RIMIC signals RXMAIN-A with RXMAIN-B (TXBACKUP-A with TXBACKUP-B) and the interchange of ROMIC signals TXMAIN-A with TXMAIN-B (RXBACKUP-A with RXBACKUP-B) will not affect functionality, and is permitted by this part of ISO/IEC 8802.

Within the concentrator, the main ring signal transmission path shall be from RIMIC signals RXMAIN-A and RXMAIN-B, through the TCUs, and out ROMIC signals TXMAIN-A and TXMAIN-B. If a station attached to a TCU is inserted, the path within that TCU shall be altered as follows:

- a) The incoming signal lines (RXMAIN-A and RXMAIN-B from the RIMIC or LRX-B and LRX-A from an upstream TCU) are connected to the TCU lobe CMIC output contacts LTX-A and LTX-B.
- b) The CMIC input contacts LRX-B and LRX-A, receiving signals from the lobe, are connected to either the next downstream TCU or to ROMIC signals TXMAIN-A and TXMAIN-B.

Also provided as part of the trunk interface is a back-up path from ROMIC signals RXBACKUP-B and RXBACKUP-A to RIMIC signals TXBACKUP-B and TXBACKUP-A. All connections described in this subclause are illustrated in figure 48.

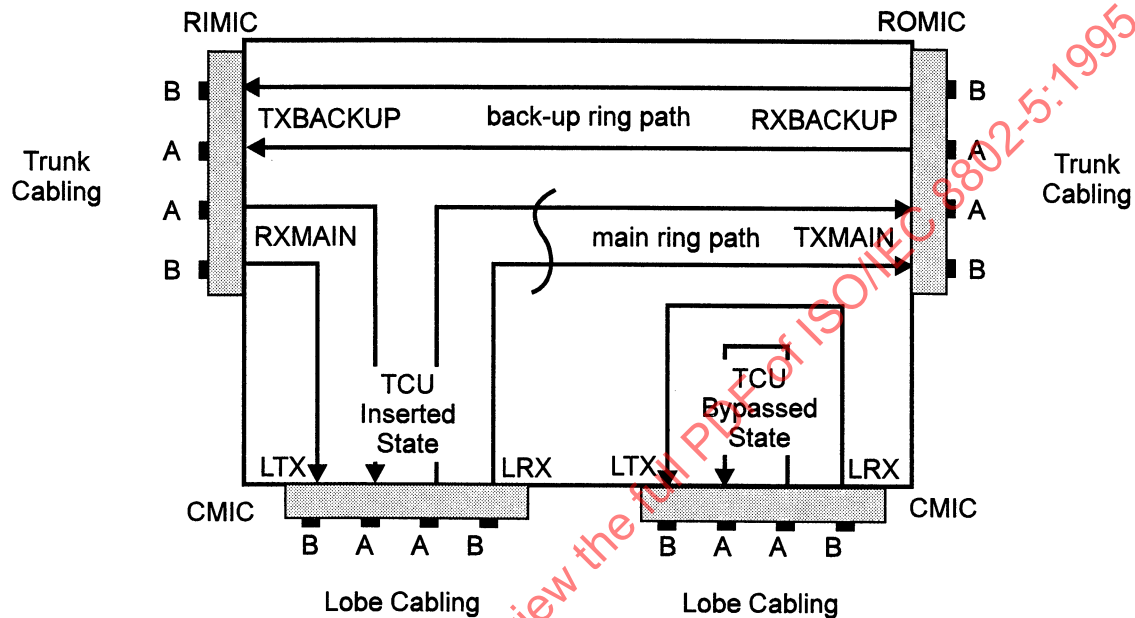

Figure 48—Example of transmission path through a concentrator

The concentrator shall provide a means, at both the RIMIC and ROMIC, by which the main ring path can be looped to the backup path in the absence of an attached trunk cable. The means can be either external or internal to the concentrator and connects RXMAIN-A to TXBACKUP-B (TXMAIN-A to RXBACKUP-B) and RXMAIN-B to TXBACKUP-A (TXMAIN-B to RXBACKUP-A).

### 8.3 Ring access control function

The concentrator shall provide a ring access control function (RAC) on each lobe port to receive requests from the station for ring insertion and ring bypass, as specified in 7.2.1. The RAC shall receive the station ring insertion and ring bypass requests from the phantom signaling channel as shown in figure 29. Each STP or UTP lobe port shall provide two independent dc isolated paths for the station's phantom signaling. The leakage resistance between the two phantom paths shall be at least 250 kΩ. One path shall be between CMIC signal pin LRX-A and LTX-A. The other path shall be between CMIC signal pin LRX-B and LTX-B. The mechanism that controls ring insertion and bypass shall be provided on both of the paths or on one of the paths with the other path containing the load balancing circuitry.

### 8.3.1 Concentrator ring insertion and ring bypass

When a ring insertion request is received by the concentrator from a station, the RAC shall, unless instructed otherwise by higher level management functions,<sup>22</sup> insert the station into the ring. When the concentrator receives the ring bypass request, the RAC shall remove the station from the ring. The station shall be inserted into the ring and bypassed from the ring when the phantom signal from a compliant station, within the required power and no power regions, respectively, as specified in 7.2.1.1, is presented at the CMIC after a maximum lobe cable dc loop resistance of 100  $\Omega$ .

In the ring insert state, the RAC shall connect the lobe's LTX signals to either the RI port receive signals (RXMAIN) or an upstream port's LRX signals, and the lobe's LRX signals to either the RO port transmit signals (TXMAIN) or a downstream lobe's LTX, thereby including the station in the main ring path as shown in figure 48. When the concentrator port is in the ring bypass state, RAC shall connect the CMIC signal pins, LRX-A to LTX-A and LRX-B to LTX-B, to provide a loop back path to the station, which permits the station to perform off-line loop back tests.

### 8.3.2 Ring insertion/bypass timing

When the concentrator port TCU switches between the ring insertion and ring bypass modes, the port RAC shall ensure that the ring trunk circuit is open no more than 5.0 ms. The time from receipt of request to completion of ring insertion shall be a maximum of 5 s<sup>23</sup> or ring bypass a maximum of 190 ms.<sup>24</sup>

The ring bypass shall meet the above requirements independent of when and how long power was previously applied to the lobe port. To provide protection against phantom glitches causing momentary ring insertions, it is recommended that the TCU require that the ring insertion request be present for at least 50 ms<sup>25</sup> before the TCU switches to the insert state.

### 8.3.3 Concentrator ring access control loads

The loads presented by each of the two phantom paths shall have and maintain a resistance between 2.9 k $\Omega$  and 5.3 k $\Omega$  within 5 s<sup>26</sup> after ring insertion until station removal. Given equal and valid phantom voltages, the lower load resistance shall be within 15% of the higher load resistance and the lower load current shall be within 15% of the higher load current.

<sup>22</sup> Higher level management function is referring to a concentrator management function that will not be described or specified herein but may be present in a concentrator and is permitted to deny the ring insertion request. Care must be taken by the management function when denying a station's ring insertion request to ensure the effect on the station's MAC protocol does not effect the overall ring performance. It is further recommended that if the higher level management function detects a faulty station attachment and denies access it should indicate the possible fault to the user or management function.

<sup>23</sup> This requirement is constrained by the MAC timer insert delay (TID) and the MAC timer join ring (TJR).

<sup>24</sup> This requirement is constrained by the specifications of 7.2.1.1 and the MAC timer remove wait (TRW). This also requires that the concentrator prevent internal energy storage devices (e.g., capacitors) from discharging into the station phantom circuits as the phantom voltage drops in a transition from "power" 0 to "no power". This is typically accomplished by using diodes to block this discharge.

<sup>25</sup> This recommendation is constrained by 7.2.1.1 and to conditions seen in earlier versions of adapters not compliant with this standard.

<sup>26</sup> This requirement is constrained by the MAC timer wire fault delay (TWFD).

## 8.4 Passive concentrator

This clause defines the electrical characteristics of the passive concentrator port. The passive concentrator contains no active elements in the lobe path and is included as one of the components in the channel. The passive concentrator may be used where the cabling plant is such that the signal's degradation due to channel impairments are within the drive distance limits supported by a token ring station. Passive concentrators may contain repeaters at the trunk ports to provide ring segment boundaries at the concentrator trunk port connectors. Implementors shall include in the published specification for the passive concentrator whether the RI and RO ports represent ring segment boundaries.

An exemplary implementation of the passive concentrator is shown in figure 49. The TCU is the only functional element in the data path between the LRX connections and the LTX connections in a passive concentrator. In order to ensure interoperability between implementations, the passive concentrator shall meet the specifications in this subclause.

All resistive loads (terminations or sources impedances) discussed in this subclause used to measure concentrator characteristics have a  $\pm 1\%$  tolerance unless otherwise noted.

### 8.4.1 Passive concentrator return loss

Passive concentrators with or without ring segment boundaries shall meet the return loss requirements specified in 8.4.1.1. Passive concentrators with passive trunk ports shall meet the reflection coefficient requirements specified in 8.4.1.2. Passive concentrators with ring segment boundaries shall meet the return loss requirements specified in 8.4.1.3.

#### 8.4.1.1 Passive concentrator with or without ring segment boundaries

The return loss is measured in the frequency domain at the TX and RX connector pins of each concentrator port excluding paths that include ring segment boundaries. Measurements conducted on the TX connector pins of a port will be terminated at the port's RX connector pins with 100  $\Omega$  (UTP) or 150  $\Omega$  (STP). Similarly, measurements conducted on a port's RX connector pins will be terminated at the TX connector pins. Two types of measurements shall be conducted 1) with the port in the inserted state with any other port bypassed or inserted and terminated with 100  $\Omega$  (UTP) or 150  $\Omega$  (STP), and 2) with the port in the bypassed state. The passive concentrator excluding paths that include ring segment boundaries shall provide a minimum return loss, relative to a reference impedance of 150  $\Omega$  (STP) or 100  $\Omega$  (UTP), as shown in table 35.

**Table 35—Maximum return loss for passive concentrators including ring segment boundaries**

Frequency range	Minimum return loss
1 MHz to 17 MHz	14 dB
17 MHz to 25 MHz	11 dB

#### 8.4.1.2 Passive concentrators without ring segment boundaries

To ensure interoperability in a network of cascaded passive concentrators that do not contain ring segment boundaries, the reflection coefficient is measured on passive concentrators without ring segment boundaries. The reflection coefficient is measured in the time domain with a 200 kHz trapezoid with a rise and fall times (10% to 90%) of 8 ns issued by a differential generator of impedance 150  $\Omega$  (STP) or 100  $\Omega$  (UTP). The port at the opposite end from the generator shall be terminated with a load of matched impedance, 150  $\Omega$  (STP) or 100  $\Omega$  (UTP). Two types of measurements shall be conducted trunk port-to-trunk port and lobe port-to-trunk port. The trunk port-to-trunk port is measured with all lobe ports bypassed and is measured from TXMAIN with RXMAIN terminated and from TXBACKUP with RXBACKUP terminated. The lobe port-to-trunk port is measured at each lobe port with the remaining lobe ports bypassed and is measured from LRX with TXMAIN terminated and LTX with RXMAIN terminated. The passive concentrator without ring segment boundaries shall provide a maximum reflection coefficient shown in table 36.

**Table 36—Maximum reflection coefficients for a passive concentrator without ring segment boundaries**

Absolute value maximum reflection coefficient ( $\rho$ )	Description
0.126	Trunk port-to-trunk port
0.178	Lobe port-to-trunk port

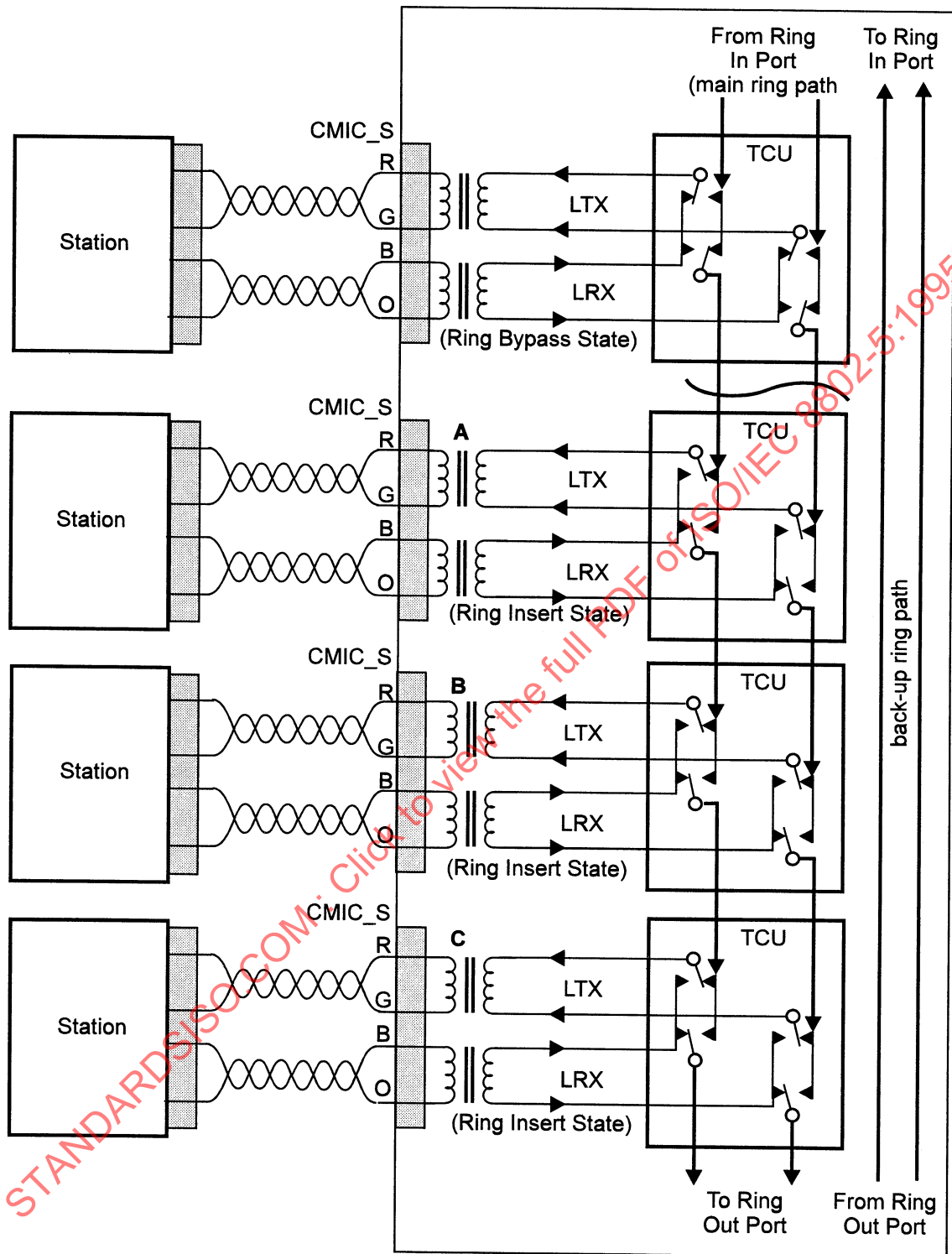

Figure 49—Example of an STP passive concentrator's signal path

### 8.4.1.3 Passive concentrator with ring segment boundaries

For paths that include ring segment boundaries, at least one port must be measured wherein the return loss of the ring segment boundaries transmitter shall meet the requirements of 7.2.2.4.<sup>27</sup> Similarly, at least one port must be measured wherein the return loss of the ring segment boundaries receiver shall meet the requirements of 7.2.3.2.<sup>27</sup>

### 8.4.2 Passive concentrator attenuation

The passive concentrator attenuation consists of four types: lobe square-root-frequency attenuation (CLSQA), lobe flat attenuation (CLATT), trunk square-root-frequency attenuation (CTSQA), and trunk flat attenuation (CTATT). Maximum CLSQA and CLATT must be included in the calculation of the channel losses. CLSQA and CLATT are based on the worst-case specified loss for the transmission path from a CMIC onto the main ring path, to the RO port's self-shortening mechanism, on to the backup path to the RI port's self-shortening mechanism, back on to the main ring path, and back to the same CMIC if there are no ring segment boundaries. CLSQA and CLATT are based on the worst-case measured loss from any TX to any RX connector pins of each concentrator port excluding any retimed path. In addition, if multiple concentrators are cascaded and the trunk ports are passive trunk ports, CTSQA and CTATT must also be included in the channel losses. The implementor shall include in the published specification for the device the maximum CLSQA both at 4 MHz and 16 MHz and CLATT. If the trunk ports are passive trunk ports, the implementor shall also include in the published specification for the device the maximum CTSQA both at 4 MHz and 16 MHz and CTATT. The measurements for CLSQA and CLATT should be taken on the maximum path between the LTX and LRX connector pins on any inserted lobe port. CTSQA and CTATT should be measured between RXMAIN and TXBACKUP with the RO port externally looped (TXMAIN to RXBACKUP). For passive concentrators with small attenuation values it may be necessary to cascade multiple concentrators to obtain reliable results. All measurements shall be based on power loss. In all cases the maximum flat loss shall be

$CLATT + n \cdot CTATT \leq 2 \text{ dB}$ ,<sup>28</sup> where  $n$  is the maximum number of concentrators in a ring segment.

$C_xATT$  and  $C_xSQA$ , where  $x$  is L or T, shall be determined by the following procedure:

- a) The insertion loss in dB,  $IL_i$ , is measured at the following frequencies:

$$F_i = i * 1E6 \text{ Hz, where } i \text{ is an integer that ranges from 1 to 30}$$

- b) A linear least squares fit of the equation is

$$IL = C_xSQA * SF + C_xATT \text{ where } SF = \begin{cases} \text{SQRT}(F/16E6) & \text{for the 16 MHz case} \\ \text{SQRT}(F/4E6) & \text{for the 4 MHz case} \end{cases}$$

to the 30 pairs of  $IL_i$  and  $F_i$  data points is made, yielding

$C_xSQA$  and  $C_xATT$ .

### 8.4.3 Passive concentrator low-frequency attenuation response

The passive concentrator low-frequency attenuation cutoff ( $C_xF1$ ), or low-frequency 3 dB point, consists of two specifications: trunk low-frequency cutoff (CTF1) and lobe low-frequency cutoff (CLF1). The

<sup>27</sup> It may be necessary to make this measurement on devices modified from standard production hardware because of software, controls, etc. It shall be acceptable to make these tests on such modified devices provided the manufacturer can show that the modifications made do not affect the electrical characteristics of the transmission path being measured.

<sup>28</sup> The channel requirements in 7.2.4 specify a maximum flat loss limit for the channel of 2 dB. The CATT may limit the maximum number of cascaded concentrators within a ring segment, and hence the number of stations that may be connected to that segment. Implementors should ensure that the CATT and CSQA are considered when determining their maximum cascaded configuration in a ring segment. Additional information relative to the role of CATT and CSQA are given in 7.2.4 and in annex B.

measurement shall be taken on the passive trunk and lobe paths as described above in 8.4.2. For passive trunk ports, CTF1 shall meet the following specification:

$$\text{CTF1} < 1 \text{ kHz}$$

For the lobe ports, CLF1 shall meet the following specification:

$$\text{CLF1} < 25 \text{ kHz}$$

#### 8.4.4 Passive concentrator crosstalk

The passive concentrator crosstalk is measured as follows:

- a) On each port (individually) from its LTX to its LRX with all ports in the insert state and their LRX and LTX terminated at the port in 100  $\Omega$  (UTP) or 150  $\Omega$  (STP)
- b) From RXMAIN to TXBACKUP with RI and RO inserted and terminated and all lobe ports bypassed except the last lobe port directly upstream of RO is inserted and terminated.
- c) The same as b) except from RXBACKUP to TXMAIN with the first lobe port directly downstream of the RI inserted and terminated.

The passive concentrator shall provide a minimum crosstalk loss as shown in table 37.

**Table 37—Passive concentrator minimum crosstalk requirements**

Frequency range	Minimum crosstalk loss
0.5 MHz to 4 MHz	43 dB
4 MHz to 24 MHz	40 dB

### 8.5 Active retiming concentrator

This subclause defines the electrical characteristics of the active retiming concentrator (ARC) lobe and trunk ports. The ARC may be used to support lobe cabling lengths beyond the limits provided by a passive concentrator as imposed by signal degradation due to channel impairments. The ARC retimes signals passing through its ports and restores signal amplitude and shape. The data path in the ARC will include three functional blocks: the trunk ports, TCU, and lobe ports. The ports implement a transmitter, including all circuitry in the transmission path between the data retiming (latching) mechanism and the CMIC (RIMIC or ROMIC) transmit connections; and the receiver, including all circuitry between the CMIC (RIMIC or ROMIC) receive connections and the recovered clock used to latch the data. An example of the ARC lobe port transmitter and receiver is shown in figure 50.

#### 8.5.1 ARC port

In order to ensure interoperability between implementations and to provide a physical containment of the channels, each port of the ARC, including the lobe, RI, and RO ports, shall provide a transmitter meeting the specifications of 7.2.2, a receiver meeting the specifications of 7.2.3, and an overall PHY performance meeting the specifications of 7.1. The ARC lobe port transmitter and receiver shall be specified with the worst-case phantom voltage mismatch allowed by 7.2.1.1.

### 8.5.2 ARC concentrator specific components

The ARC port clock recovery circuit shall be phase synchronized within 1.5 ms after receipt of a valid signal from the upstream station. In the determination of the minimum supported PMC count (see table 32) the ARC port is counted as one PMC. Burst error correction, if implemented, shall only occur on burst6 errors correcting to burst5. The clock recovery circuit may transmit fill, preferably from a crystal clock, while frequency error is occurring. The ARC retiming elements, which are not part of the active monitor, shall not delete bits in the interframe gap if the deletion reduces the size of the interframe gap below the minimum size specified in 3.2.10. To ensure active retimed concentrators do not introduce excessive latency, the average PMC latency should not exceed 100 symbols<sup>29</sup> per port to prevent expiration of timer TRR (3.4.2.13). It is recommended that the port latency be minimized in order to maximize performance/access.

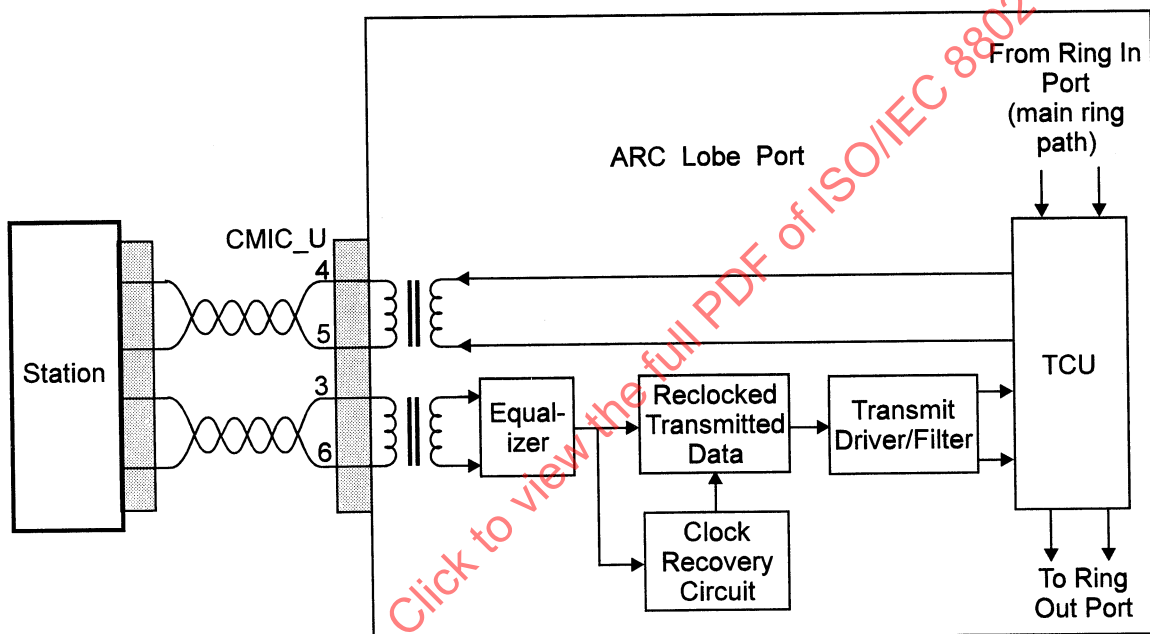

Figure 50—Example of the ARC lobe port transmitter and receiver

<sup>29</sup> For 4 Mbit/s operation this number is based upon the assumption that a ring is comprised of a maximum number of ARC ports and stations of 125 each and 100 m lobe length cables (with a propagation speed of 0.7 times the speed of light) and with no trunk cabling.

## Annex A

(normative)

### Protocol Implementation Conformance Statement (PICS) proforma

#### A.1 Introduction

The supplier of a protocol implementation that is claimed to conform to this standard shall complete the following Protocol Implementation Conformance Statement (PICS) proforma.

A completed PICS proforma is the PICS for the implementation in question. The PICS is a statement of which capabilities and options of the protocol have been implemented. The PICS can have a number of uses, including use by the following:

- a) The protocol implementor, as a check-list to reduce the risk of failure to conform to the standard through oversight;
- b) The supplier and acquirer, or potential acquirer, of the implementation, as a detailed indication of the capabilities of the implementation, stated relative to the common basis for understanding provided by the standard PICS proforma;
- c) The user, or potential user, of the implementation, as a basis for initially checking the possibility of interworking with another implementation (note that, while interworking can never be guaranteed, failure to interwork can often be predicted from incompatible PICSs);
- d) The protocol tester, as the basis for selecting appropriate tests against which to assess the claim for conformance of the implementation.

#### A.2 Abbreviations and special symbols

##### A.2.1 Status symbols

The following symbols are used in the PICS proforma:

M	mandatory field/function
O	optional field/function
O.<n>	optional field/function indicating mutually exclusive or selectable options among a set
X	prohibited field/function
<item>	simple-predicate condition, dependent on the support marked for <item>

##### A.2.2 Abbreviations

N/A	Not applicable
-----	----------------

#### A.3 Instructions for completing the PICS proforma

##### A.3.1 General structure for the PICS proforma

The first part of the PICS proforma, implementation identification and protocol summary, is to be completed as indicated with the information necessary to identify fully both the supplier and the implementation.

The main part of the PICS proforma is a fixed-format questionnaire divided into subclauses, each containing a group of items. Answers to the questionnaire items are to be provided in the right-most column, either by simply marking an answer to indicate a restricted choice (usually Yes, No, or Not Applicable), or by entering a value, or a set or a range of values. (Note that there are some items where two or more choices from a set of possible answers can apply; all relevant choices are to be marked.)

Each item is identified by an item reference in the first column; the second column contains the question to be answered; the third column contains the reference or references to the material that specifies the item in the main body of the standard. The remainder of the columns record the status of the item—whether the support is mandatory, optional, or conditional—and provide spaces for the answers; see also A.3.4.

The supplier may also provide, or be required to provide, further information, categorized as either “additional information” or “exception information.” When present, each kind of further information is to be provided in a further subclause of items labeled A<i> or E<i>, respectively, for cross-referencing purposes, where <i> is the unambiguous identification for the item (e.g., simply a numerical); there are no other restrictions on its format or presentation.

A completed PICS proforma, including any additional information or exception information, is the PICS for the implementation in question.

Note that where an implementation is capable of being configured in more than one way, according to the items listed in A.5, a single PICS may be able to describe all such configurations. However, the supplier has the choice of providing more than one PICS, each covering some subset of the implementation’s configuration capabilities, if that would make presentation of information easier and cleaner.

### **A.3.2 Additional information**

Items of additional information allow a supplier to provide further information intended to assist the interpretation of the PICS. It is not intended or expected that a large quantity will be supplied, and the PICS can be considered complete without any such information. Examples might be an outline of the ways in which a (single) implementation can be set up to operate in a variety of environments and configurations; or a brief rationale, based perhaps upon specific application needs, for the exclusion of features which, although optional, are nonetheless commonly present in implementations of the token ring protocol.

References to items of additional information may be entered next to any answer in the questionnaire, and may be included in items of exception information.

### **A.3.3 Exception information**

It may occasionally happen that a supplier will wish to answer an item with mandatory status or prohibited status (after any conditions have been applied) in a way that conflicts with the indicated requirement. No preprinted answer will be found in the Support column for this; instead, the supplier is required to write into the Support column an E<i> reference to an item of exception information, and to provide the appropriate rationale in the exception item itself.

An implementation for which an exception item is required in this way does not conform to this standard.

Note that a possible reason for the situation described above is that a defect in the standard has been reported, a correction for which is expected to change the requirement not met by the implementation.

### A.3.4 Conditional status

#### A.3.4.1 Conditional items

The PICS proforma contains a number of conditional items. These are items for which the status—mandatory, optional, or prohibited—that applies is dependent upon whether or not certain other items are supported, or upon the value supported for other items.

In many cases, whether or not the item applies at all is conditional in this way, as well as the status when the item does not apply.

A conditional symbol is of the form “<pred>: <s>” where “<pred>” is a predicate as described in A.3.4.2, and “<s>” is one of the status symbols M, O, O.<n>, or X.

A conditional symbol of the form “<pred> : :” may be indicated above a particular table. That table shall be completed if and only if the condition evaluates to true.

#### A.3.4.2 Predicates

A predicate is one of the following:

- a) An item-reference for an item in the PICS proforma. The value of the predicate is true if the item is marked as supported, and is false otherwise; or
- b) A predicate name for a predicate defined elsewhere in the PICS proforma (usually in the major capabilities section or at the end of the section containing the conditional item), see (a), (b), (c); or
- c) The logical negation symbol “¬” prefixed to an item-reference or predicate name. The value of the predicate is true if the value of the predicate formed by omitting the “¬” symbol is false, and vice versa.

The definition for a predicate name is one of the following:

- a) An item-reference, evaluated as at (1) above; or
- b) A relation containing a comparison operator (i.e., = , < , etc.) with at least one of its operands being an item-reference for an item taking numerical values as its answer. The predicate is true if the relation holds when each item-reference is replaced by the value entered in the Support column as answer to the item referred to; or
- c) A Boolean expression constructed by combining simple predicates, as at (a) and (b), using the Boolean operators AND, OR, and NOT, and parentheses, in the usual way. The value of such a predicate is true if the Boolean expression evaluates to true when the simple predicates are interpreted as described previously.

Each item-reference that is used in a predicate or predicate definition is indicated by an asterisk in the Item column. If such item reference is not supported (false), then the support of the item itself will be indicated as N/A (not applicable); otherwise, the support of the item will be indicated as YES.

## A.4 Identification

### A.4.1 Implementation identification

Supplier	
Contact point for queries about the PICS	
Implementation name(s) and version(s)	
Other information necessary for full identification—e.g., name(s) and version(s) for machines and/or operating systems; system name(s)	
<p>NOTES</p> <p>1—Only the first three items are required for all implementations; other information may be completed as appropriate in meeting the requirements for full identification.</p> <p>2—The terms <i>name</i> and <i>version</i> should be interpreted appropriately to correspond with a supplier's terminology (e.g., type, series, model).</p>	

### A.4.2 Protocol summary

Protocol version	
Amendments implemented	
Corrigenda implemented	
<p>Have any exception items been required? No <input type="checkbox"/> Yes <input type="checkbox"/> (See A.3.3; the answer "Yes" means that the implementation does not conform to the standard.)</p>	
Date of statement	

### A.5 Major capabilities

Item	Feature	Reference	Status	Support
*DS	Data station	2.4	O.1	Yes <input type="checkbox"/> No <input type="checkbox"/>
*ACON	Active retiming concentrator	8.5	O.1	Yes <input type="checkbox"/> No <input type="checkbox"/>
*PCON	Passive concentrator	8.4	O.1	Yes <input type="checkbox"/> No <input type="checkbox"/>
*DR4	4 Mbit/s data rate	5.3	O.2	Yes <input type="checkbox"/> No <input type="checkbox"/>
*DR16	16 Mbit/s data rate	5.3	O.2	Yes <input type="checkbox"/> No <input type="checkbox"/>
*STP	Shielded twisted pair cable attachment	7.2	O.3	Yes <input type="checkbox"/> No <input type="checkbox"/>
*UTP	Unshielded twisted pair cable attachment	7.2	O.3	Yes <input type="checkbox"/> No <input type="checkbox"/>
NOTES— O.1: Support for one and only one of the options is required. O.2 and O.3: Support for at least one of the options is required.				

### A.6 PICS proforma for the MAC sublayer

#### A.6.1 Transmission formats—DS::M

Does the data station support the following frame formats?

Item	Feature	Reference	Status	Support
FF1	Token transmit	3.1.1	M	Yes <input type="checkbox"/>
FF1A	Token receive	3.1.1	M	Yes <input type="checkbox"/>
FF2	MAC frame transmit	3.1.2	M	Yes <input type="checkbox"/>
FF2A	MAC frame receive	3.1.2	M	Yes <input type="checkbox"/>
FF3	LLC frame transmit	3.1.2	M	Yes <input type="checkbox"/>
FF3A	LLC frame receive	3.1.2	M	Yes <input type="checkbox"/>
FF4	Abort sequence transmit	3.1.3	M	Yes <input type="checkbox"/>
FF4A	Abort sequence receive	3.1.3	M	Yes <input type="checkbox"/>
FF5	Fill transmit	3.1.4	M	Yes <input type="checkbox"/>
FF5A	Fill receive	3.1.4	M	Yes <input type="checkbox"/>

**A.6.2 Frame parameters—DS::M**

Does the data station support the following frame parameters?

Item	Feature	Reference	Status	Support
FP1	Starting delimiter transmit	3.2.1	M	Yes <input type="checkbox"/>
FP1A	Starting delimiter receive	3.2.1	M	Yes <input type="checkbox"/>
FP2	Access control transmit	3.2.2	M	Yes <input type="checkbox"/>
FP2A	Access control receive	3.2.2	M	Yes <input type="checkbox"/>
FP3	Frame control transmit	3.2.3	M	Yes <input type="checkbox"/>
FP3A	Frame control receive	3.2.3	M	Yes <input type="checkbox"/>
FP4	Destination address transmit	3.2.4.1	M	Yes <input type="checkbox"/>
FP4A	Destination address receive	3.2.4.1	M	Yes <input type="checkbox"/>
FP5	Source address transmit	3.2.4.2	M	Yes <input type="checkbox"/>
FP5A	Source address receive	3.2.4.2	M	Yes <input type="checkbox"/>
FP6	Routing information indicator transmit	3.2.4.2	M	Yes <input type="checkbox"/>
FP6A	Routing information indicator receive	3.2.4.2	M	Yes <input type="checkbox"/>
*FP7	Routing information field transmit	3.2.5	O	Yes <input type="checkbox"/> No <input type="checkbox"/>
FP7A	Routing information field receive	3.2.5	M	Yes <input type="checkbox"/>
FP8	RI field length bits transmit	3.2.5	FP7: M	N/A <input type="checkbox"/> Yes <input type="checkbox"/>
FP8A	RI field length bits receive	3.2.5	M	Yes <input type="checkbox"/>
FP9	MAC frame, info field transmit	3.2.6.2	M	Yes <input type="checkbox"/>
FP9A	MAC frame, info field receive	3.2.6.2	M	Yes <input type="checkbox"/>
FP10	LLC frame, info field transmit	3.2.6.3	M	Yes <input type="checkbox"/>
FP10A	LLC frame, info field receive Minimum 133 octets	3.2.6.3	M	Yes <input type="checkbox"/> _____ octets
FP11	Frame check sequence transmit	3.2.7	M	Yes <input type="checkbox"/>
FP11A	Frame check sequence receive	3.2.7	M	Yes <input type="checkbox"/>
FP12	Ending delimiter transmit	3.2.8	M	Yes <input type="checkbox"/>
FP12A	Ending delimiter receive	3.2.8	M	Yes <input type="checkbox"/>
FP13	Frame status transmit	3.2.9	M	Yes <input type="checkbox"/>
FP13A	Frame status receive	3.2.9	M	Yes <input type="checkbox"/>

**A.6.3 MAC frames—DS::M**

Does the data station support the following MAC frames?

Item	Feature	Reference	Status	Support
MV00T	Response transmit	3.3.3	M	Yes <input type="checkbox"/>
MV02T	Beacon transmit	3.3.3	M	Yes <input type="checkbox"/>
MV02R	Beacon receive	3.3.3	M	Yes <input type="checkbox"/>
MV03T	Claim token transmit	3.3.3	M	Yes <input type="checkbox"/>
MV03R	Claim token receive	3.3.3	M	Yes <input type="checkbox"/>
MV04T	Ring purge transmit	3.3.3	M	Yes <input type="checkbox"/>
MV04R	Ring purge receive	3.3.3	M	Yes <input type="checkbox"/>
MV05T	Active monitor present transmit	3.3.3	M	Yes <input type="checkbox"/>
MV05R	Active monitor present receive	3.3.3	M	Yes <input type="checkbox"/>
MV06T	Standby monitor present transmit	3.3.3	M	Yes <input type="checkbox"/>
MV06R	Standby monitor present receive	3.3.3	M	Yes <input type="checkbox"/>
MV07T	Duplicate address test transmit	3.3.3	M	Yes <input type="checkbox"/>
MV07R	Duplicate address test receive	3.3.3	M	Yes <input type="checkbox"/>
MV0BR	Remove station receive	3.3.3	M	Yes <input type="checkbox"/>
MV0CR	Change parameters receive	3.3.3	M	Yes <input type="checkbox"/>
MV0DR	Initialize station receive	3.3.3	M	Yes <input type="checkbox"/>
MV0ER	Request station addresses receive	3.3.3	M	Yes <input type="checkbox"/>
MV0FR	Request ring station state receive	3.3.3	M	Yes <input type="checkbox"/>
MV10R	Request station attachments receive	3.3.3	M	Yes <input type="checkbox"/>
MV20T	Request initialization transmit	3.3.3	M	Yes <input type="checkbox"/>
MV22T	Report station addresses transmit	3.3.3	M	Yes <input type="checkbox"/>
MV23T	Report station state transmit	3.3.3	M	Yes <input type="checkbox"/>
MV24T	Report station attachments transmit	3.3.3	M	Yes <input type="checkbox"/>
MV25T	Report new active monitor transmit	3.3.3	M	Yes <input type="checkbox"/>
MV26T	Report SUA change transmit	3.3.3	M	Yes <input type="checkbox"/>
MV27T	Report neighbor notification incomplete transmit	3.3.3	M	Yes <input type="checkbox"/>
MV28T	Report active monitor error transmit	3.3.3	M	Yes <input type="checkbox"/>
MV29T	Report error transmit	3.3.3	M	Yes <input type="checkbox"/>

#### A.6.4 MAC frame subvectors—DS::M

Does the data station support the following subvectors?

Item	Feature	Reference	Status	Support
SV01T	Beacon type transmit	3.3.4	M	Yes <input type="checkbox"/>
SV01R	Beacon type receive	3.3.4	M	Yes <input type="checkbox"/>
SV02T	Upstream neighbor's address transmit	3.3.4	M	Yes <input type="checkbox"/>
SV02R	Upstream neighbor's address receive	3.3.4	M	Yes <input type="checkbox"/>
SV03R	Local ring number receive	3.3.4	M	Yes <input type="checkbox"/>
SV04R	Assign physical drop number receive	3.3.4	M	Yes <input type="checkbox"/>
SV05R	Error report timer value receive	3.3.4	M	Yes <input type="checkbox"/>
SV06T	Authorized function classes transmit	3.3.4	M	Yes <input type="checkbox"/>
SV06R	Authorized function classes receive	3.3.4	M	Yes <input type="checkbox"/>
SV07T	Authorized access priority transmit	3.3.4	M	Yes <input type="checkbox"/>
SV07R	Authorized access priority receive	3.3.4	M	Yes <input type="checkbox"/>
SV09T	Correlator transmit	3.3.4	O	Yes <input type="checkbox"/> No <input type="checkbox"/>
SV09R	Correlator receive	3.3.4	M	Yes <input type="checkbox"/>
SV0AT	SA of last AMP or SMP fame transmit	3.3.4	M	Yes <input type="checkbox"/>
SV0B4T	Group address transmit—4-octet data field	3.3.4	O.4	Yes <input type="checkbox"/> No <input type="checkbox"/>
SV0B6T	Group address transmit—6-octet data field	3.3.4	O.4	Yes <input type="checkbox"/> No <input type="checkbox"/>
SV20T	Response code transmit	3.3.4	M	Yes <input type="checkbox"/>
SV22T	Product instance ID transmit	3.3.4	O	Yes <input type="checkbox"/> No <input type="checkbox"/>
SV23T	Ring station version number transmit	3.3.4	O	Yes <input type="checkbox"/> No <input type="checkbox"/>
SV28T	Station identifier transmit	3.3.4	M	Yes <input type="checkbox"/>
SV29T	Ring station status vector transmit	3.3.4	M	Yes <input type="checkbox"/>
SV2BT	Physical drop number transmit	3.3.4	O	Yes <input type="checkbox"/> No <input type="checkbox"/>
SV2BR	Physical drop number receive	3.3.4	M	Yes <input type="checkbox"/>
SV2CT	Functional address transmit	3.3.4	M	Yes <input type="checkbox"/>
SV2DT	Isolating error counts transmit	3.3.4	M	Yes <input type="checkbox"/>
SV2BT	Nonisolating error counts transmit	3.3.4	M	Yes <input type="checkbox"/>
SV30T	Error code transmit	3.3.4	M	Yes <input type="checkbox"/>

NOTE—O.4: Support of one and only one option is required.

**A.6.5 Timers—DS::M**

Does the data station support the following timers as specified in the referenced subclause of the standard? Note that the time intervals are applicable only when observable from external behavior. No particular realization is implied.

Item	Feature	Reference	Status	Support
TAM	Active monitor	3.4.2.1	M	Yes <input type="checkbox"/>
TBR	Beacon repeat	3.4.2.2	M	Yes <input type="checkbox"/>
TBT	Beacon transmit	3.4.2.3	M	Yes <input type="checkbox"/>
TCT	Claim token	3.4.2.4	M	Yes <input type="checkbox"/>
TER	Error report	3.4.2.5	M	Yes <input type="checkbox"/>
TID	Insert delay	3.4.2.6	M	Yes <input type="checkbox"/>
TJR	Join ring	3.4.2.7	M	Yes <input type="checkbox"/>
TNT	No token	3.4.2.8	M	Yes <input type="checkbox"/>
TQP	Queue PDU	3.4.2.9	M	Yes <input type="checkbox"/>
TRH	Remove hold	3.4.2.10	M	Yes <input type="checkbox"/>
TRI	Request initialization	3.4.2.12	M	Yes <input type="checkbox"/>
TRP	Ring purge	3.4.2.14	M	Yes <input type="checkbox"/>
TRR	Return to repeat	3.4.2.13	M	Yes <input type="checkbox"/>
TRW	Remove wait	3.4.2.11	M	Yes <input type="checkbox"/>
TSL	Signal loss	3.4.2.15	M	Yes <input type="checkbox"/>
TSM	Standby monitor	3.4.2.16	M	Yes <input type="checkbox"/>
TVX	Valid transmission	3.4.2.17	M	Yes <input type="checkbox"/>
TWF	Wire fault	3.4.2.19	M	Yes <input type="checkbox"/>
TWFD	Wire fault delay	3.4.2.18	M	Yes <input type="checkbox"/>

### A.6.6 Station policy flags—DS::M

Note that the following requirements are applicable only when observable from external behavior.

Item	Feature	Reference	Status	Support
FBHO_0	Flag, beacon handling option—flag=0	3.5.1	O.5	Yes <input type="checkbox"/> No <input type="checkbox"/>
FBHO_1	Flag, beacon handling option—flag=1	3.5.1	O.5	Yes <input type="checkbox"/> No <input type="checkbox"/>
FCCO_0	Flag, claim contender option—flag=0	3.5.2	O.6	Yes <input type="checkbox"/> No <input type="checkbox"/>
FCCO_1	Flag, claim contender option—flag=1	3.5.2	O.6	Yes <input type="checkbox"/> No <input type="checkbox"/>
FETO_0	Flag, ETR option—flag=0	3.5.3	DR4: M DR16:O.7	N/A <input type="checkbox"/> Yes <input type="checkbox"/> N/A <input type="checkbox"/> Yes <input type="checkbox"/> No <input type="checkbox"/>
FETO_1	Flag, ETR option—flag=1	3.5.3	DR16:O.7	N/A <input type="checkbox"/> Yes <input type="checkbox"/> No <input type="checkbox"/>
FECO_0	Flag, error counting option—flag=0	3.5.4	O.8	Yes <input type="checkbox"/> No <input type="checkbox"/>
FECO_1	Flag, error counting option—flag=1	3.5.4	O.8	Yes <input type="checkbox"/> No <input type="checkbox"/>
FMRO_0	Flag, media rate—flag=0	3.5.5	DR4:M	N/A <input type="checkbox"/> Yes <input type="checkbox"/>
FMRO_1	Flag, media rate—flag=1	3.5.5	DR16:M	N/A <input type="checkbox"/> Yes <input type="checkbox"/>
FMFTO_0	Flag, multiple frame transmission—flag=0	3.5.6	O.9	Yes <input type="checkbox"/> No <input type="checkbox"/>
FMFTO_1	Flag, multiple frame transmission—flag=1	3.5.6	O.9	Yes <input type="checkbox"/> No <input type="checkbox"/>
FRRO_0	Flag, reject remove option—flag=0	3.5.7	O.10	Yes <input type="checkbox"/> No <input type="checkbox"/>
FRRO_1	Flag, reject remove option—flag=1	3.5.7	O.10	Yes <input type="checkbox"/> No <input type="checkbox"/>
FTEO_0	Flag, token error detect option—flag=0	3.5.8	O.11	Yes <input type="checkbox"/> No <input type="checkbox"/>
FTEO_1	Flag, token error detect option—flag=1	3.5.8	O.11	Yes <input type="checkbox"/> No <input type="checkbox"/>
FTHO_0	Flag, token handling option—flag=0	3.5.9	O.12	Yes <input type="checkbox"/> No <input type="checkbox"/>
FTHO_1	Flag, token handling option—flag=1	3.5.9	O.12	Yes <input type="checkbox"/> No <input type="checkbox"/>
FGTO_0	Flag, good token option—flag=0	3.5.10	O.13	Yes <input type="checkbox"/> No <input type="checkbox"/>
FGTO_1	Flag, good token option—flag=1	3.5.10	O.13	Yes <input type="checkbox"/> No <input type="checkbox"/>
NOTE—Support of at least one of the options shown above is required.				

**A.6.7 Counters—DS::M**

These counters are considered to be visible externally only through the transmission of the Report Error MAC frame (see 3.3.5, table 4).

Item	Feature	Reference	Status	Support
CABE	Abort error	3.6.1	M	Yes <input type="checkbox"/>
CACE	AC error	3.6.2	M	Yes <input type="checkbox"/>
CBE	Burst error	3.6.3	M	Yes <input type="checkbox"/>
CFCE	Frame-copied error	3.6.4	M	Yes <input type="checkbox"/>
CFE	Frequency error	3.6.5	O	Yes <input type="checkbox"/> No <input type="checkbox"/>
CIE	Internal error	3.6.6	O	Yes <input type="checkbox"/> No <input type="checkbox"/>
CLE	Line error	3.6.7	M	Yes <input type="checkbox"/>
CLFE	Lost frame error	3.6.8	M	Yes <input type="checkbox"/>
CRCE	Receive congestion error	3.6.9	M	Yes <input type="checkbox"/>
CTE	Token error	3.6.10	M	Yes <input type="checkbox"/>

**A.7 PICS proforma for the physical layer**

**A.7.1 Symbol timing—DS::M, ACON::M**

Do the data station and the active concentrator support the following symbol timings?

Item	Feature	Reference	Status	Support
ST1	4 Mbit/s data signaling rate	5.2	DR4: M	N/A <input type="checkbox"/> Yes <input type="checkbox"/>
ST2	16 Mbit/s data signaling rate	5.2	DR16: M	N/A <input type="checkbox"/> Yes <input type="checkbox"/>
ST3	Acquire phase lock within 1.5 ms	5.7.1	M	Yes <input type="checkbox"/>
ST4	Frequency error	5.7.2	O	Yes <input type="checkbox"/> No <input type="checkbox"/>
ST5	Signal loss indication	5.7.1	O	Yes <input type="checkbox"/> No <input type="checkbox"/>

**A.7.2 Symbol encoding and decoding—DS::M**

Do the data station and the active concentrator support the following symbol encoding and decoding?

Item	Feature	Reference	Status	Support
SY1	Symbol encoding	5.3	M	Yes <input type="checkbox"/>
SY2	Symbol decoding	5.6	M	Yes <input type="checkbox"/>
SY3	Burst error/idles transmit	5.4.2	M	Yes <input type="checkbox"/>

### A.7.3 Station latency—DS::M

Does the data station provide for the following latencies?

Item	Feature	Reference	Status	Support
LB1	A fixed latency buffer of 24 symbols	5.8.2	M	Yes <input type="checkbox"/>
LB2	4 Mbit/s latency variation	5.8.3	DR4: M	N/A <input type="checkbox"/> Yes <input type="checkbox"/>
LB3	16 Mbit/s latency variation	5.8.3	DR16: M	N/A <input type="checkbox"/> Yes <input type="checkbox"/>

### A.7.4 Access control

DS::M Does the data station support the following access control?

Item	Feature	Reference	Status	Support
RA1	Perform ring access control	5.9	M	Yes <input type="checkbox"/>
RA2	Phantom circuit source/return	7.2.1.1	M	Yes <input type="checkbox"/>
RA3	Ring insertion current/voltage	7.2.1.1	M	Yes <input type="checkbox"/>
RA4	Ring bypass current/voltage	7.2.1.1	M	Yes <input type="checkbox"/>
RA5	Lobe fault indication	7.2.1.2	M	Yes <input type="checkbox"/>

ACON::M, PCON::M Does the concentrator support the following access control?

Item	Feature	Reference	Status	Support
CRAC1	Ring insertion max time	8.3.2	M	Yes <input type="checkbox"/>
CRAC2	Ring bypass max time	8.3.2	M	Yes <input type="checkbox"/>
CRAC3	Phantom dc load	8.3.3	M	Yes <input type="checkbox"/>
CRAC4	Max ring open time	8.3.2	M	Yes <input type="checkbox"/>
CRAC5	Phantom path leakage resistance	8.3	M	Yes <input type="checkbox"/>
CRAC6	Ring access control insert & bypass	8.3.1	M	Yes <input type="checkbox"/>

**A.8. Attachment specifications****A.8.1 Accumulated correlated jitter—DS::M, ACON::M**

Do the data station and the active concentrator support the following specifications?

Item	Feature	Reference	Status	Support
AJ1a	Filtered accumulated phase jitter	7.1.1	DR4: M	N/A <input type="checkbox"/> Yes <input type="checkbox"/>
AJ1b	Filtered accumulated phase jitter	7.1.1	DR16: M	N/A <input type="checkbox"/> Yes <input type="checkbox"/>
AJ2a	Delta phase accumulated phase jitter	7.1.1	DR4: M	N/A <input type="checkbox"/> Yes <input type="checkbox"/>
AJ2b	Delta phase accumulated phase jitter	7.1.1	DR16: M	N/A <input type="checkbox"/> Yes <input type="checkbox"/>
AJ3a	Accumulated uncorrelated jitter	7.1.2	DR4: M	N/A <input type="checkbox"/> Yes <input type="checkbox"/>
AJ3b	Accumulated uncorrelated jitter	7.1.2	DR16: M	N/A <input type="checkbox"/> Yes <input type="checkbox"/>
AJ4	PHY net delay	7.1.3	M	Yes <input type="checkbox"/>

**A.8.2 Transmitter specification—DS::M, ACON::M**

Do the data station and the active concentrator support the following specifications?

Item	Feature	Reference	Status	Support
TR1a	Transmit duty cycle distortion	7.2.2.1	DR4: M	N/A <input type="checkbox"/> Yes <input type="checkbox"/>
TR1b	Transmit duty cycle distortion	7.2.2.1	DR16: M	N/A <input type="checkbox"/> Yes <input type="checkbox"/>
TR2a	Transmit Tdiff01	7.2.2.2.1	DR4: M	N/A <input type="checkbox"/> Yes <input type="checkbox"/>
TR2b	Transmit Tdiff01	7.2.2.2.1	DR16: M	N/A <input type="checkbox"/> Yes <input type="checkbox"/>
TR3	Transmit Tdiffmax	7.2.2.2.1	M	Yes <input type="checkbox"/>
TR4a	Transmit waveform(zero/one/SDEL)	7.2.2.2.2	DR4: M	N/A <input type="checkbox"/> Yes <input type="checkbox"/>
TR4b	Transmit waveform(zero/one/SDEL)	7.2.2.2.2	DR16: M	N/A <input type="checkbox"/> Yes <input type="checkbox"/>
TR5a	Transmit output voltage	7.2.2.3	STP: M	N/A <input type="checkbox"/> Yes <input type="checkbox"/>
TR5b	Transmit output voltage	7.2.2.3	UTP: M	N/A <input type="checkbox"/> Yes <input type="checkbox"/>
TR6a	Transmit return loss	7.2.2.4	STP: M	N/A <input type="checkbox"/> Yes <input type="checkbox"/>
TR6b	Transmit return loss	7.2.2.4	UTP: M	N/A <input type="checkbox"/> Yes <input type="checkbox"/>

### A.8.3 Receiver specification—DS::M, ACON::M

Do the data station and the active concentrator support the following receiver specifications?

Item	Feature	Reference	Status	Support
RC1a	Rcvr jitter tolerance (no noise)	7.2.3.1	DR4: M	N/A <input type="checkbox"/> Yes <input type="checkbox"/>
TR1b	Rcvr jitter tolerance (no noise)	7.2.3.1	DR16: M	N/A <input type="checkbox"/> Yes <input type="checkbox"/>
RC2a	Rcvr jitter tolerance (with noise)	7.2.3.1	DR4: M	N/A <input type="checkbox"/> Yes <input type="checkbox"/>
TR2b	Rcvr jitter tolerance (with noise)	7.2.3.1	DR16: M	N/A <input type="checkbox"/> Yes <input type="checkbox"/>
TR3a	Rcvr return loss	7.2.3.2	DR4: M	N/A <input type="checkbox"/> Yes <input type="checkbox"/>
TR3b	Rcvr return loss	7.2.3.2	DR16: M	N/A <input type="checkbox"/> Yes <input type="checkbox"/>

### A.8.4 Connector specification

DS::M Does the data station support the following connector specification?

Item	Feature	Reference	Status	Support
MI1	STP media interface connector	7.2.5.1	STP: M	N/A <input type="checkbox"/> Yes <input type="checkbox"/>
MI2	UTP media interface connector	7.2.5.2	UTP: M	N/A <input type="checkbox"/> Yes <input type="checkbox"/>

ACON::M, PCON::M Does the concentrator support the following specifications?

Item	Feature	Reference	Status	Support
CC1a	STP media lobe connector	8.1.1	STP: M	N/A <input type="checkbox"/> Yes <input type="checkbox"/>
CC1b	UTP media lobe connector	8.1.1	UTP: M	N/A <input type="checkbox"/> Yes <input type="checkbox"/>
CC2a	Trunk connected STP MIC	8.2.1	O.14	Yes <input type="checkbox"/> No <input type="checkbox"/>
CC2b	Trunk connected UTP MIC	8.2.1	O.14	Yes <input type="checkbox"/> No <input type="checkbox"/>
CC2c	No trunk connection	8.2.1	O.14	Yes <input type="checkbox"/> No <input type="checkbox"/>
CC3	Main ring signal path	8.2.1	M	Yes <input type="checkbox"/>
CC4a	Trunk connected backup signal path	8.2.1	O.15	Yes <input type="checkbox"/> No <input type="checkbox"/>
CC4b	No trunk connection	8.2.1	O.15	Yes <input type="checkbox"/> No <input type="checkbox"/>
CC5	Lobe port indicators	8.2.1	O	Yes <input type="checkbox"/> No <input type="checkbox"/>
NOTE—Support of at least one of each option shown above is required.				

**A.9 Concentrator specific requirements****ACON::M** Does the active concentrator support the following specifications?

Item	Feature	Reference	Status	Support
AC1	Burst error correction	8.5.2	O	Yes <input type="checkbox"/> No <input type="checkbox"/>
AC2	Deleting interframe bits	8.5.2	O	Yes <input type="checkbox"/> No <input type="checkbox"/>
AC3a	Ring segment trunk port	8.2	O.16	Yes <input type="checkbox"/> No <input type="checkbox"/>
AC3b	No trunk port	8.2	O.16	Yes <input type="checkbox"/> No <input type="checkbox"/>
NOTE—Support of at least one of each option shown above is required.				

**PCON::M** Does the passive concentrator support the following specifications?

Item	Feature	Reference	Status	Support
CPA1	Lobe return loss	8.4.1.1	M	Yes <input type="checkbox"/>
CPA2a	Trunk reflection coefficient	8.4.1.2	O.17	Yes <input type="checkbox"/> No <input type="checkbox"/>
CPA2b	Ring segment boundary return loss	8.4.1.3	O.17	Yes <input type="checkbox"/> No <input type="checkbox"/>
CPA2c	No passive trunk	8.4.1	O.17	Yes <input type="checkbox"/> No <input type="checkbox"/>
CPA3	Maximum flat loss	8.4.2	M	Yes <input type="checkbox"/>
CPA4	Published lobe attenuation values	8.4.2	M	Yes <input type="checkbox"/>
CPA5	Crosstalk loss	8.4.4	M	Yes <input type="checkbox"/>
CPA6	Lobe low-frequency response	8.4.3	M	Yes <input type="checkbox"/>
CPA7a	Passive trunk low-frequency response	8.4.3	O.18	Yes <input type="checkbox"/> No <input type="checkbox"/>
CPA7b	No passive trunk	8.4.3	O.18	Yes <input type="checkbox"/> No <input type="checkbox"/>
CPA8a	Published passive trunk port	8.4	O.19	Yes <input type="checkbox"/> No <input type="checkbox"/>
CPA8b	Published ring segment boundary trunk port	8.4	O.19	Yes <input type="checkbox"/> No <input type="checkbox"/>
CPA8c	No trunk port	8.4	O.19	Yes <input type="checkbox"/> No <input type="checkbox"/>
CPA9a	Published passive trunk attenuation values	8.4.2	O.20	Yes <input type="checkbox"/> No <input type="checkbox"/>
CPA9b	No passive trunk	8.4.2	O.20	Yes <input type="checkbox"/> No <input type="checkbox"/>
NOTE—Support of at least one option shown above is required.				

## Annex B

(informative)

### Channel design considerations

This annex provides channel design examples and cabling guidelines to aid users in implementing the passive and active channels specified in 7.2.4. Implementation of the channels specified in 7.2.4 is intended to result in a jitter budget, as specified in annex C, with sufficient margin to ensure a bit error rate (BER) not exceeding  $10^{-9}$  for a station and  $10^{-8}$  for the ring when connected to equipment that conforms to this standard.

#### B.1 Channel transmission parameters

When designing a passive or active channel, the primary channel transmission parameters of interest are

- a) Insertion loss,
- b) NEXT Loss-to-Insertion Loss Ratio (NIR), and
- c) Total flat loss for passive channels. The channel impedance is satisfied by selecting the appropriate media.

##### B.1.1 Insertion loss

As specified in 7.2.4.2.1, the insertion loss of the passive and active channels is the loss between the MIC at a transmitter and the MIC of the next downstream receiver. This loss includes all the components in the channel, which are shown in table B.1 for passive and active channels. As shown in figure 37, the passive channel path includes two lobes since both channel terminations are at the station MICs. Hence, there are at least twice the number of components in a passive channel as there are in an active channel. The concentrator losses are not included in the active channel since the active channel is defined between a station MIC and a concentrator MIC and, between the RI and RO MIC ports of concentrators. Flexible cords used in the channel that do not match the attenuation of the building cable as specified in ISO/IEC 11801 : 1995, should be taken into account when calculating the length of channel components.

**Table B.1—Channel components**

Component	Passive channel	Active channel
Cords and cables	Station cords Building cables Patch cords Equipment cords	Station cord Building cable Patch cord Equipment cord
Connectors	Wall outlets Equipment and cable termination blocks	Wall outlet Equipment and cable termination blocks
Concentrator	Concentrator(s) Inter-concentrator cord(s)	

##### B.1.2 Channel noise

As discussed in 7.2.4.3, the noise that appears at the output of a channel consists of two types: crosstalk noise due to signals within the lobe cabling from an adjacent channel and noise induced into the channel