

INTERNATIONAL
STANDARD

ISO/
IEC/IEEE
8802-3

Third edition
2021-02

AMENDMENT
2022-07

**Telecommunications and exchange
between information technology
systems — Requirements for local and
metropolitan area networks —**

Part 3:
Standard for Ethernet

**AMENDMENT 11: Physical layers and
management parameters for 100 Gb/s
and 400 Gb/s operation over single-
mode fiber at 100 Gb/s per wavelength**

*Télécommunications et échange entre systèmes informatiques —
Exigences pour les réseaux locaux et métropolitains —*

Partie 3: Norme pour Ethernet

*AMENDEMENT 11: Couches physiques et paramètres de gestion pour
le fonctionnement à 100 Gb/s et 400 Gb/s sur fibre unimodale à 100
Gb/s par longueur d'onde*



Reference number
ISO/IEC/IEEE 8802-3:2021/Amd.11:2022(E)

© IEEE 2021

STANDARDSISO.COM : Click to view the full PDF of ISO/IEC/IEEE 8802-3:2021/Amd 11:2022



COPYRIGHT PROTECTED DOCUMENT

© IEEE 2021

All rights reserved. Unless otherwise specified, or required in the context of its implementation, no part of this publication may be reproduced or utilized otherwise in any form or by any means, electronic or mechanical, including photocopying, or posting on the internet or an intranet, without prior written permission. Permission can be requested from IEEE at the address below.

Institute of Electrical and Electronics Engineers, Inc
3 Park Avenue, New York
NY 10016-5997, USA

Email: stds.ipr@ieee.org
Website: www.ieee.org

Published in Switzerland

Foreword

ISO (the International Organization for Standardization) and IEC (the International Electrotechnical Commission) form the specialized system for worldwide standardization. National bodies that are members of ISO or IEC participate in the development of International Standards through technical committees established by the respective organization to deal with particular fields of technical activity. ISO and IEC technical committees collaborate in fields of mutual interest. Other international organizations, governmental and non-governmental, in liaison with ISO and IEC, also take part in the work.

The procedures used to develop this document and those intended for its further maintenance are described in the ISO/IEC Directives, Part 1. In particular, the different approval criteria needed for the different types of ISO/IEC documents should be noted. This document was drafted in accordance with the editorial rules of the ISO/IEC Directives, Part 2 (see www.iso.org/directives or www.iec.ch/members_experts/refdocs).

IEEE Standards documents are developed within the IEEE Societies and the Standards Coordinating Committees of the IEEE Standards Association (IEEE-SA) Standards Board. The IEEE develops its standards through a consensus development process, approved by the American National Standards Institute, which brings together volunteers representing varied viewpoints and interests to achieve the final product. Volunteers are not necessarily members of the Institute and serve without compensation. While the IEEE administers the process and establishes rules to promote fairness in the consensus development process, the IEEE does not independently evaluate, test, or verify the accuracy of any of the information contained in its standards.

Attention is drawn to the possibility that some of the elements of this document may be the subject of patent rights. ISO and IEC shall not be held responsible for identifying any or all such patent rights. Details of any patent rights identified during the development of the document will be in the Introduction and/or on the ISO list of patent declarations received (see www.iso.org/patents) or the IEC list of patent declarations received (see <https://patents.iec.ch>).

Any trade name used in this document is information given for the convenience of users and does not constitute an endorsement.

For an explanation of the voluntary nature of standards, the meaning of ISO specific terms and expressions related to conformity assessment, as well as information about ISO's adherence to the World Trade Organization (WTO) principles in the Technical Barriers to Trade (TBT), see www.iso.org/iso/foreword.html. In the IEC, see www.iec.ch/understanding-standards.

ISO/IEC/IEEE 8802-3:2021/Amd 11 was prepared by the LAN/MAN of the IEEE Computer Society (as IEEE 802.3cu™-2021) and drafted in accordance with its editorial rules. It was adopted, under the “fast-track procedure” defined in the Partner Standards Development Organization cooperation agreement between ISO and IEEE, by Joint Technical Committee ISO/IEC JTC 1, *Information technology, Subcommittee SC 6, Telecommunications and information exchange between systems*.

A list of all parts in the ISO/IEC/IEEE 8802 series can be found on the ISO and IEC websites.

Any feedback or questions on this document should be directed to the user's national standards body. A complete listing of these bodies can be found at www.iso.org/members.html and www.iec.ch/national-committees.

STANDARDSISO.COM : Click to view the full PDF of ISO/IEC/IEEE 8802-3:2021/Amd 11:2022

IEEE Std 802.3cu™-2021

(Amendment to IEEE Std 802.3™-2018
as amended by IEEE Std 802.3cb™-2018,
IEEE Std 802.3bt™-2018,
IEEE Std 802.3cd™-2018,
IEEE Std 802.3cn™-2019,
IEEE Std 802.3cg™-2019,
IEEE Std 802.3cq™-2020,
IEEE Std 802.3cm™-2020,
IEEE Std 802.3ch™-2020,
IEEE Std 802.3ca™-2020,
and IEEE Std 802.3cr™-2020)

IEEE Standard for Ethernet

Amendment 11: Physical Layers and Management Parameters for 100 Gb/s and 400 Gb/s Operation over Single-Mode Fiber at 100 Gb/s per Wavelength

Developed by the

LAN/MAN Standards Committee
of the
IEEE Computer Society

Approved 9 February 2021

IEEE SA Standards Board

Abstract: This amendment to IEEE Std 802.3-2018 adds Physical Layer specifications and management parameters for 100 Gb/s and 400 Gb/s Ethernet optical interfaces for reaches up to 10 km based on 100 Gb/s per wavelength optical signaling.

Keywords: 100 Gb/s Ethernet, 100GBASE-FR1, 100GBASE-LR1, 400 Gb/s Ethernet, 400GBASE-FR4, 400GBASE-LR4-6, Energy-Efficient Ethernet (EEE), Ethernet, forward error correction (FEC), IEEE 802.3™, IEEE 802.3cu™, PAM4, Physical Medium Dependent (PMD) sublayer, single-mode fiber (SMF)

The Institute of Electrical and Electronics Engineers, Inc.
3 Park Avenue, New York, NY 10016-5997, USA

Copyright © 2021 by The Institute of Electrical and Electronics Engineers, Inc.
All rights reserved. Published 26 February 2021. Printed in the United States of America.

IEEE and 802 are registered trademarks in the U.S. Patent & Trademark Office, owned by The Institute of Electrical and Electronics Engineers, Incorporated.

PDF: ISBN 978-1-5044-7383-5 STD24602
Print: ISBN 978-1-5044-7384-2 STDPD24602

IEEE prohibits discrimination, harassment and bullying.

For more information, visit <http://www.ieee.org/web/aboutus/whatis/policies/p9-26.html>.

No part of this publication may be reproduced in any form, in an electronic retrieval system or otherwise, without the prior written permission of the publisher.

Important Notices and Disclaimers Concerning IEEE Standards Documents

IEEE Standards documents are made available for use subject to important notices and legal disclaimers. These notices and disclaimers, or a reference to this page (<https://standards.ieee.org/ipr/disclaimers.html>), appear in all standards and may be found under the heading “Important Notices and Disclaimers Concerning IEEE Standards Documents.”

Notice and Disclaimer of Liability Concerning the Use of IEEE Standards Documents

IEEE Standards documents are developed within the IEEE Societies and the Standards Coordinating Committees of the IEEE Standards Association (IEEE SA) Standards Board. IEEE develops its standards through an accredited consensus development process, which brings together volunteers representing varied viewpoints and interests to achieve the final product. IEEE Standards are documents developed by volunteers with scientific, academic, and industry-based expertise in technical working groups. Volunteers are not necessarily members of IEEE or IEEE SA, and participate without compensation from IEEE. While IEEE administers the process and establishes rules to promote fairness in the consensus development process, IEEE does not independently evaluate, test, or verify the accuracy of any of the information or the soundness of any judgments contained in its standards.

IEEE makes no warranties or representations concerning its standards, and expressly disclaims all warranties, express or implied, concerning this standard, including but not limited to the warranties of merchantability, fitness for a particular purpose and non-infringement. In addition, IEEE does not warrant or represent that the use of the material contained in its standards is free from patent infringement. IEEE Standards documents are supplied “AS IS” and “WITH ALL FAULTS.”

Use of an IEEE standard is wholly voluntary. The existence of an IEEE Standard does not imply that there are no other ways to produce, test, measure, purchase, market, or provide other goods and services related to the scope of the IEEE standard. Furthermore, the viewpoint expressed at the time a standard is approved and issued is subject to change brought about through developments in the state of the art and comments received from users of the standard.

In publishing and making its standards available, IEEE is not suggesting or rendering professional or other services for, or on behalf of, any person or entity, nor is IEEE undertaking to perform any duty owed by any other person or entity to another. Any person utilizing any IEEE Standards document, should rely upon his or her own independent judgment in the exercise of reasonable care in any given circumstances or, as appropriate, seek the advice of a competent professional in determining the appropriateness of a given IEEE standard.

IN NO EVENT SHALL IEEE BE LIABLE FOR ANY DIRECT, INDIRECT, INCIDENTAL, SPECIAL, EXEMPLARY, OR CONSEQUENTIAL DAMAGES (INCLUDING, BUT NOT LIMITED TO: THE NEED TO PROCURE SUBSTITUTE GOODS OR SERVICES; LOSS OF USE, DATA, OR PROFITS; OR BUSINESS INTERRUPTION) HOWEVER CAUSED AND ON ANY THEORY OF LIABILITY, WHETHER IN CONTRACT, STRICT LIABILITY, OR TORT (INCLUDING NEGLIGENCE OR OTHERWISE) ARISING IN ANY WAY OUT OF THE PUBLICATION, USE OF, OR RELIANCE UPON ANY STANDARD, EVEN IF ADVISED OF THE POSSIBILITY OF SUCH DAMAGE AND REGARDLESS OF WHETHER SUCH DAMAGE WAS FORESEEABLE.

Translations

The IEEE consensus development process involves the review of documents in English only. In the event that an IEEE standard is translated, only the English version published by IEEE is the approved IEEE standard.

Official statements

A statement, written or oral, that is not processed in accordance with the IEEE SA Standards Board Operations Manual shall not be considered or inferred to be the official position of IEEE or any of its committees and shall not be considered to be, nor be relied upon as, a formal position of IEEE. At lectures, symposia, seminars, or educational courses, an individual presenting information on IEEE standards shall make it clear that the presenter's views should be considered the personal views of that individual rather than the formal position of IEEE, IEEE SA, the Standards Committee, or the Working Group.

Comments on standards

Comments for revision of IEEE Standards documents are welcome from any interested party, regardless of membership affiliation with IEEE or IEEE SA. However, **IEEE does not provide interpretations, consulting information, or advice pertaining to IEEE Standards documents.**

Suggestions for changes in documents should be in the form of a proposed change of text, together with appropriate supporting comments. Since IEEE standards represent a consensus of concerned interests, it is important that any responses to comments and questions also receive the concurrence of a balance of interests. For this reason, IEEE and the members of its Societies and Standards Coordinating Committees are not able to provide an instant response to comments, or questions except in those cases where the matter has previously been addressed. For the same reason, IEEE does not respond to interpretation requests. Any person who would like to participate in evaluating comments or in revisions to an IEEE standard is welcome to join the relevant IEEE working group. You can indicate interest in a working group using the Interests tab in the Manage Profile & Interests area of the [IEEE SA myProject system](#). An IEEE Account is needed to access the application.

Comments on standards should be submitted using the [Contact Us](#) form.

Laws and regulations

Users of IEEE Standards documents should consult all applicable laws and regulations. Compliance with the provisions of any IEEE Standards document does not constitute compliance to any applicable regulatory requirements. Implementers of the standard are responsible for observing or referring to the applicable regulatory requirements. IEEE does not, by the publication of its standards, intend to urge action that is not in compliance with applicable laws, and these documents may not be construed as doing so.

Data privacy

Users of IEEE Standards documents should evaluate the standards for considerations of data privacy and data ownership in the context of assessing and using the standards in compliance with applicable laws and regulations.

Copyrights

IEEE draft and approved standards are copyrighted by IEEE under US and international copyright laws. They are made available by IEEE and are adopted for a wide variety of both public and private uses. These include both use, by reference, in laws and regulations, and use in private self-regulation, standardization, and the promotion of engineering practices and methods. By making these documents available for use and adoption by public authorities and private users, IEEE does not waive any rights in copyright to the documents.

Photocopies

Subject to payment of the appropriate licensing fees, IEEE will grant users a limited, non-exclusive license to photocopy portions of any individual standard for company or organizational internal use or individual, non-commercial use only. To arrange for payment of licensing fees, please contact Copyright Clearance Center, Customer Service, 222 Rosewood Drive, Danvers, MA 01923 USA; +1 978 750 8400; <https://www.copyright.com/>. Permission to photocopy portions of any individual standard for educational classroom use can also be obtained through the Copyright Clearance Center.

Updating of IEEE Standards documents

Users of IEEE Standards documents should be aware that these documents may be superseded at any time by the issuance of new editions or may be amended from time to time through the issuance of amendments, corrigenda, or errata. An official IEEE document at any point in time consists of the current edition of the document together with any amendments, corrigenda, or errata then in effect.

Every IEEE standard is subjected to review at least every 10 years. When a document is more than 10 years old and has not undergone a revision process, it is reasonable to conclude that its contents, although still of some value, do not wholly reflect the present state of the art. Users are cautioned to check to determine that they have the latest edition of any IEEE standard.

In order to determine whether a given document is the current edition and whether it has been amended through the issuance of amendments, corrigenda, or errata, visit [IEEE Xplore](#) or [contact IEEE](#). For more information about the IEEE SA or IEEE's standards development process, visit the IEEE SA Website.

Errata

Errata, if any, for all IEEE standards can be accessed on the [IEEE SA Website](#). Search for standard number and year of approval to access the web page of the published standard. Errata links are located under the Additional Resources Details section. Errata are also available in [IEEE Xplore](#). Users are encouraged to periodically check for errata.

Patents

IEEE Standards are developed in compliance with the [IEEE SA Patent Policy](#).

Attention is called to the possibility that implementation of this standard may require use of subject matter covered by patent rights. By publication of this standard, no position is taken by the IEEE with respect to the existence or validity of any patent rights in connection therewith. If a patent holder or patent applicant has filed a statement of assurance via an Accepted Letter of Assurance, then the statement is listed on the IEEE SA Website at <https://standards.ieee.org/about/sasb/patcom/patents.html>. Letters of Assurance may indicate whether the Submitter is willing or unwilling to grant licenses under patent rights without compensation or under reasonable rates, with reasonable terms and conditions that are demonstrably free of any unfair discrimination to applicants desiring to obtain such licenses.

Essential Patent Claims may exist for which a Letter of Assurance has not been received. The IEEE is not responsible for identifying Essential Patent Claims for which a license may be required, for conducting inquiries into the legal validity or scope of Patents Claims, or determining whether any licensing terms or conditions provided in connection with submission of a Letter of Assurance, if any, or in any licensing agreements are reasonable or non-discriminatory. Users of this standard are expressly advised that determination of the validity of any patent rights, and the risk of infringement of such rights, is entirely their own responsibility. Further information may be obtained from the IEEE Standards Association.

IMPORTANT NOTICE

IEEE Standards do not guarantee or ensure safety, security, health, or environmental protection, or ensure against interference with or from other devices or networks. IEEE Standards development activities consider research and information presented to the standards development group in developing any safety recommendations. Other information about safety practices, changes in technology or technology implementation, or impact by peripheral systems also may be pertinent to safety considerations during implementation of the standard. Implementers and users of IEEE Standards documents are responsible for determining and complying with all appropriate safety, security, environmental, health, and interference protection practices and all applicable laws and regulations.

Participants

The following individuals were officers and members of the IEEE 802.3 Working Group at the beginning of the IEEE P802.3cu Working Group ballot.

David J. Law, *IEEE 802.3 Working Group Chair*
Adam Healey, *IEEE 802.3 Working Group Vice-Chair*
Jon Lewis, *IEEE 802.3 Working Group Secretary*
Steven B. Carlson, *IEEE 802.3 Working Group Executive Secretary*
Valerie Maguire, *IEEE 802.3 Working Group Treasurer*

Mark Nowell, *IEEE P802.3cu 100 Gb/s and 400 Gb/s over SMF at 100 Gb/s per Wavelength Task Force Chair*

Gary Nicholl, *IEEE P802.3cu 100 Gb/s and 400 Gb/s over SMF at 100 Gb/s per Wavelength Task Force Editor-in-Chief*

David Lewis, *IEEE P802.3cu 100 Gb/s and 400 Gb/s over SMF at 100 Gb/s per Wavelength Task Force Editor*

David Abramson	Hideki Goto	Mike-Peng Li
Pete Anslow	Steffen Graber	Alex Lin
Michikazu Aono	Olaf Grau	Hai-Feng Liu
Nobuyasu Araki	Robert Grow	William Lo
Tim Baggett	Martin Gubow	Kent Lusted
Thananya Baldwin	Mark Gustlin	Jeffery Maki
Steven Baumgartner	Marek Hajduczenia	David Malicoat
Denis Beaudoin	Howard Heck	Eric Maniloff
Gitesh Bhagwat	Brian Holden	Flavio Marques
Rich Boyer	Bernd Hornmeyer	Arthur Marris
David Brandt	Yasuhiro Hyakutake	Takeo Masuda
Ralf-Peter Braun	Jonathan Ingham	Mick McCarthy
Theodore Brillhart	Kazuhiko Ishibe	Brett McClellan
Paul Brooks	Hideki Isono	Larry McMillan
Matthew Brown	Tom Issenhuth	Richard Mellitz
Jairo Bustos Heredia	Hiroaki Ito	Shimon Muller
Adrian Butter	Kenneth Jackson	James Nadolny
Clark Carty	Andrew Jimenez	Edward Nakamoto
David Chalupsky	John Johnson	Paul Neveux
Jacky Chang	Chad Jones	Gary Nicholl
Xin Chang	Peter Jones	Shawn Nicholl
Chan Chen	Lokesh Kabra	Kevin Noll
Golam Choudhury	Haysam Kadry	David Ofelt
Keng Hua Chuang	Manabu Kagami	Ryo Okabe
John D'Ambrosia	Upen Kareti	Tom Palkert
Piers Dawe	Athanasios Kasapi	Carlos Pardo
Fred Dawson	Yong Kim	Earl Parsons
Gerrit den Besten	Mark Kimber	Gerald Pepper
Claudio DeSanti	Michael Klempa	David Piehler
Curtis Donahue	Curtis Knittle	Fabio Pittala
Liang Du	Elizabeth Kochuparambil	Christopher Pohl
Kathryn Dube	Sam Kocsis	William Powell
Frank Effenberger	Wojciech Koczwar	Rick Rabinovich
David Estes	Paul Kolesar	Parthasarathy Raju
John Ewen	Taiji Kondo	Adee Ran
Vincent Ferretti	Daniel Koppermueller	Alon Regev
Brian Franchuk	Glen Kramer	Duane Remein
Matthias Fritsche	Taketo Kumada	Victor Renteria
Takashi Fukuoka	Hans Lackner	Thomas Rettig
Ali Ghiasi	Frank Lambrecht	Hamid Salehi
Joel Goergen	Mark Laubach	Sam Sambasivan
Steven Gorshe	Greg Le Cheminant	Edward Sayre
		Matthew Schmitt

Hossein Sedarat
 Masood Shariff
 Masato Shiino
 Ramin Shirani
 Kapil Shrikhande
 Jeff Slavick
 Scott Sommers
 Edward Sprague
 Peter Stassar
 Heath Stewart
 Junqing Sun
 Steve Swanson
 Tomoo Takahara
 Satoshi Takahashi

Tadashi Takahashi
 Kazuya Takayama
 Michael Takefman
 Masaru Terada
 Geoffrey Thompson
 Pirooz Tooyserkani
 Nathan Tracy
 David Tremblay
 Stephen Trowbridge
 Mike Tu
 Ed Ulrichs
 Alexander Umnov
 Edward Walter
 Roy Wang

Xuehuan Wang
 Dong Wei
 Matthias Wendt
 Natalie Wienckowski
 Dance Wu
 Peter Wu
 Dayin Xu
 Yu Xu
 Lennart Yseboodt
 Conrad Zerna
 Xingxin Zhang
 Chunhui Zhu
 Yan Zhuang
 Martin Zielinski
 George Zimmerman

The following members of the individual balloting committee voted on this standard. Balloters may have voted for approval, disapproval, or abstention.

Robert Aiello
 Thomas Alexander
 Ralf-Peter Braun
 Theodore Brillhart
 Matthew Brown
 Jairo Bustos Heredia
 William Byrd
 Steven B. Carlson
 Clark Carty
 Pin Chang
 Chan Chen
 Charles Cook
 Piers Dawe
 John Deandrea
 Michael Dudek
 Avraham Freedman
 Matthias Fritsche
 Robert Grow
 Joseph Gwinn
 Xiang He
 Adam Healey
 Marco Hernandez
 David Hess
 Werner Hoelzl
 Thomas Huber
 Yasuhiro Hyakutake
 Jonathan Ingham
 Osamu Ishida
 Hideki Isono
 Chad Jones

Peter Jones
 Lokesh Kabra
 Piotr Karocki
 Stuart Kerry
 Yong Kim
 Mark Laubach
 David J. Law
 Pi-Cheng Law
 Hyeong Ho Lee
 David Lewis
 Jon Lewis
 Karen Liu
 Kent Lusted
 Valerie Maguire
 Jeffery Maki
 Michael Maytum
 Brett McClellan
 Jonathon Melendon
 Richard Mellitz
 Guangcan Mi
 Tremont Miao
 Raymond Nering
 Gary Nicholl
 Nick S. A. Nikjoo
 Mark Nowell
 Satoshi Obara
 Tom Palkert
 Carlos Pardo
 Earl Parsons
 Bansii Patel

David Piehler
 Rick Pimpinella
 R. K. Rannow
 Alon Regev
 Maximilian Riegel
 Robert Robinson
 Roberto Rodes
 Toshiaki Sakai
 Olindo Savi
 Jason Shriver
 Scott Sommers
 Peter Stassar
 Walter Struppler
 Mitsutoshi Sugawara
 Kohichi Tamura
 James Theodoras
 Nathan Tracy
 David Tremblay
 Stephen Trowbridge
 Mark-Rene Uchida
 John Vergis
 Ruoxu Wang
 Brian Welch
 Andreas Wolf
 Peter Wu
 James Young
 Yu Yuan
 Oren Yuen
 Bo Zhang
 Pavel Zivny

When the IEEE SA Standards Board approved this standard on 9 February 2021, it had the following membership:

Gary Hoffman, *Chair*
Vacant Position, *Vice Chair*
John D. Kulick, *Past Chair*
Konstantinos Karachalios, *Secretary*

Edward A. Addy
Doug Edwards
Ramy Ahmed Fathy
J. Travis Griffith
Joseph L. Koepfinger*
Thomas Koshy
David J. Law
Howard Li

Daozhuang Lin
Kevin Lu
Daleep C. Mohla
Chenhui Niu
Damir Novosel
Annette Reilly
Jon Walter Rosdahl

Dorothy Stanley
Mehmet Ulema
Lei Wang
F. Keith Waters
Karl Weber
Sha Wei
Howard Wolfman
Daidi Zhong

*Member Emeritus

STANDARDSISO.COM : Click to view the full PDF of ISO/IEC/IEEE 8802-3:2021/Amd 11:2022

Introduction

This introduction is not part of IEEE Std 802.3cu-2021, IEEE Standard for Ethernet—Amendment 11: Physical Layers and Management Parameters for 100 Gb/s and 400 Gb/s Operation over Single-Mode Fiber at 100 Gb/s per Wavelength.

IEEE Std 802.3™ was first published in 1985. Since the initial publication, many projects have added functionality or provided maintenance updates to the specifications and text included in the standard. Each IEEE 802.3 project/amendment is identified with a suffix (e.g., IEEE Std 802.3ba™-2010).

The half duplex Media Access Control (MAC) protocol specified in IEEE Std 802.3-1985 is Carrier Sense Multiple Access with Collision Detection (CSMA/CD). This MAC protocol was key to the experimental Ethernet developed at Xerox Palo Alto Research Center, which had a 2.94 Mb/s data rate. Ethernet at 10 Mb/s was jointly released as a public specification by Digital Equipment Corporation (DEC), Intel and Xerox in 1980. Ethernet at 10 Mb/s was approved as an IEEE standard by the IEEE Standards Board in 1983 and subsequently published in 1985 as IEEE Std 802.3-1985. Since 1985, new media options, new speeds of operation, and new capabilities have been added to IEEE Std 802.3. A full duplex MAC protocol was added in 1997.

Some of the major additions to IEEE Std 802.3 are identified in the marketplace with their project number. This is most common for projects adding higher speeds of operation or new protocols. For example, IEEE Std 802.3u™ added 100 Mb/s operation (also called Fast Ethernet), IEEE Std 802.3z added 1000 Mb/s operation (also called Gigabit Ethernet), IEEE Std 802.3ae added 10 Gb/s operation (also called 10 Gigabit Ethernet), IEEE Std 802.3ah™ specified access network Ethernet (also called Ethernet in the First Mile) and IEEE Std 802.3ba added 40 Gb/s operation (also called 40 Gigabit Ethernet) and 100 Gb/s operation (also called 100 Gigabit Ethernet). These major additions are all now included in and are superseded by IEEE Std 802.3-2018 and are not maintained as separate documents.

At the date of IEEE Std 802.3cu-2021 publication, IEEE Std 802.3 was composed of the following documents:

IEEE Std 802.3-2018

Section One—Includes Clause 1 through Clause 20 and Annex A through Annex H and Annex 4A. Section One includes the specifications for 10 Mb/s operation and the MAC, frame formats and service interfaces used for all speeds of operation.

Section Two—Includes Clause 21 through Clause 33 and Annex 22A through Annex 33E. Section Two includes management attributes for multiple protocols and speed of operation as well as specifications for providing power over twisted pair cabling for multiple operational speeds. It also includes general information on 100 Mb/s operation as well as most of the 100 Mb/s Physical Layer specifications.

Section Three—Includes Clause 34 through Clause 43 and Annex 36A through Annex 43C. Section Three includes general information on 1000 Mb/s operation as well as most of the 1000 Mb/s Physical Layer specifications.

Section Four—Includes Clause 44 through Clause 55 and Annex 44A through Annex 55B. Section Four includes general information on 10 Gb/s operation as well as most of the 10 Gb/s Physical Layer specifications.

Section Five—Includes Clause 56 through Clause 77 and Annex 57A through Annex 76A. Clause 56 through Clause 67 and Clause 75 through Clause 77, as well as associated annexes, specify subscriber

access and other Physical Layers and sublayers for operation from 512 kb/s to 10 Gb/s, and defines services and protocol elements that enable the exchange of IEEE Std 802.3 format frames between stations in a subscriber access network. Clause 68 specifies a 10 Gb/s Physical Layer specification. Clause 69 through Clause 74 and associated annexes specify Ethernet operation over electrical backplanes at speeds of 1000 Mb/s and 10 Gb/s.

Section Six—Includes Clause 78 through Clause 95 and Annex 83A through Annex 93C. Clause 78 specifies Energy-Efficient Ethernet. Clause 79 specifies IEEE 802.3 Organizationally Specific Link Layer Discovery Protocol (LLDP) type, length, and value (TLV) information elements. Clause 80 through Clause 95 and associated annexes include general information on 40 Gb/s and 100 Gb/s operation as well the 40 Gb/s and 100 Gb/s Physical Layer specifications. Clause 90 specifies Ethernet support for time synchronization protocols.

Section Seven—Includes Clause 96 through Clause 115 and Annex 97A through Annex 115A. Clause 96 through Clause 98, Clause 104, and associated annexes, specify Physical Layers and optional features for 100 Mb/s and 1000 Mb/s operation over a single twisted pair. Clause 100 through Clause 103, as well as associated annexes, specify Physical Layers for the operation of the EPON protocol over coaxial distribution networks. Clause 105 through Clause 114 and associated annexes include general information on 25 Gb/s operation as well as 25 Gb/s Physical Layer specifications. Clause 99 specifies a MAC merge sublayer for the interspersing of express traffic. Clause 115 and its associated annex specify a Physical Layer for 1000 Mb/s operation over plastic optical fiber.

Section Eight—Includes Clause 116 through Clause 126 and Annex 119A through Annex 120E. Clause 116 through Clause 124 and associated annexes include general information on 200 Gb/s and 400 Gb/s operation as well the 200 Gb/s and 400 Gb/s Physical Layer specifications. Clause 125 and Clause 126 include general information on 2.5 Gb/s and 5 Gb/s operation as well as 2.5 Gb/s and 5 Gb/s Physical Layer specifications.

IEEE Std 802.3cb™-2018

Amendment 1—This amendment includes changes to IEEE Std 802.3-2018 and its amendments, and adds Clause 127 through Clause 130, Annex 127A, Annex 128A, Annex 128B, and Annex 130A. This amendment adds new Physical Layers for operation at 2.5 Gb/s and 5 Gb/s over electrical backplanes.

IEEE Std 802.3bt™-2018

Amendment 2—This amendment includes changes to IEEE Std 802.3-2018 and adds Clause 145, Annex 145A, Annex 145B, and Annex 145C. This amendment adds power delivery using all four pairs in the structured wiring plant, resulting in greater power being available to end devices. This amendment also allows for lower standby power consumption in end devices and adds a mechanism to better manage the available power budget.

IEEE Std 802.3cd™-2018

Amendment 3—This amendment includes changes to IEEE Std 802.3-2018 and adds Clause 131 through Clause 140 and Annex 135A through Annex 136D. This amendment adds MAC parameters, Physical Layers, and management parameters for the transfer of IEEE 802.3 format frames at 50 Gb/s, 100 Gb/s, and 200 Gb/s.

IEEE Std 802.3cn™-2019

Amendment 4—This amendment includes changes to IEEE Std 802.3-2018 and adds 50 Gb/s, 200 Gb/s, and 400 Gb/s Physical Layer specifications and management parameters for operation over single-mode fiber with reaches of at least 40 km.

IEEE Std 802.3cg™-2019

Amendment 5—This amendment includes changes to IEEE Std 802.3-2018 and its amendments and adds Clause 146 through Clause 148 and Annex 146A and Annex 146B. This amendment adds 10 Mb/s Physical Layer specifications and management parameters for operation on a single balanced pair of conductors.

IEEE Std 802.3cq™-2020

Amendment 6—This amendment includes editorial and technical corrections, refinements, and clarifications to Clause 33 and related portions of the standard.

IEEE Std 802.3cm™-2020

Amendment 7—This amendment includes changes to IEEE Std 802.3-2018 and adds Clause 150. This amendment adds Physical Layer (PHY) specifications and management parameters for 400 Gb/s operation on four pairs (400GBASE-SR4.2) and eight pairs (400GBASE-SR8) of multimode fiber, over reaches of at least 100 m.

IEEE Std 802.3ch™-2020

Amendment 8—This amendment includes changes to IEEE Std 802.3-2018 and adds Clause 149, Annex 149A, Annex 149B, and Annex 149C. This amendment adds physical layer specifications and management parameters for operation at 2.5 Gb/s, 5 Gb/s, and 10 Gb/s over a single balanced pair of conductors.

IEEE Std 802.3ca™-2020

Amendment 9—This amendment to IEEE Std 802.3-2018 extends the operation of Ethernet passive optical networks (EPONs) to multiple channels of 25 Gb/s providing both symmetric and asymmetric operation for the following data rates (downstream/upstream): 25/10 Gb/s, 25/25 Gb/s, 50/10 Gb/s, 50/25 Gb/s, and 50/50 Gb/s. This amendment specifies the 25 Gb/s EPON Multi-Channel Reconciliation Sublayer (MCRS), Nx25G-EPON Physical Coding Sublayers (PCSs), Physical Media Attachment (PMA) sublayers, and Physical Medium Dependent (PMD) sublayers that support both symmetric and asymmetric data rates while maintaining backward compatibility with already deployed 10 Gb/s EPON equipment. The EPON operation is defined for distances of at least 20 km, and for a split ratio of at least 1:32.

IEEE Std 802.3cr™-2021

Amendment 10—This amendment includes changes to IEEE Std 802.3-2018 and adds Annex J. This amendment replaces references to the IEC 60950 series of standards (including IEC 60950-1 “Information technology equipment—Safety—Part 1: General requirements”) with appropriate references to the IEC 62368 “Audio/video, information and communication technology equipment” series and makes appropriate changes to the standard corresponding to the new references.

IEEE Std 802.3cu™-2021

Amendment 11—This amendment includes changes to IEEE Std 802.3-2018 and adds Clause 151. This amendment adds Physical Layer (PHY) specifications and management parameters for 100 Gb/s and 400 Gb/s operation over single-mode fiber, based on 100 Gb/s per wavelength optical signaling.

Two companion documents exist, IEEE Std 802.3.1 and IEEE Std 802.3.2. IEEE Std 802.3.1 describes Ethernet management information base (MIB) modules for use with the Simple Network Management

ISO/IEC/IEEE 8802-3:2021/Amd.11:2022(E)

IEEE Std 802.3cu-2021
IEEE Standard for Ethernet—Amendment 11: Physical Layers and Management Parameters for
100 Gb/s and 400 Gb/s Operation over Single-Mode Fiber at 100 Gb/s per Wavelength

Protocol (SNMP). IEEE Std 802.3.2 describes YANG data models for Ethernet. IEEE Std 802.3.1 and IEEE Std 802.3.2 are updated to add management capability for enhancements to IEEE Std 802.3 after approval of those enhancements.

IEEE Std 802.3 will continue to evolve. New Ethernet capabilities are anticipated to be added within the next few years as amendments to this standard.

STANDARDSISO.COM : Click to view the full PDF of ISO/IEC/IEEE 8802-3:2021/Amd 11:2022

Contents

1. Introduction.....	18
1.4 Definitions	18
30. Management.....	19
30.5 Layer management for medium attachment units (MAUs).....	19
30.5.1 MAU managed object class.....	19
30.5.1.1 MAU attributes	19
30.5.1.1.2 aMAUType	19
45. Management Data Input/Output (MDIO) Interface.....	20
45.2 MDIO Interface Registers.....	20
45.2.1 PMA/PMD registers.....	20
45.2.1.6 PMA/PMD control 2 register (Register 1.7)	20
45.2.1.7 PMA/PMD status 2 register (Register 1.8).....	20
45.2.1.7.4 Transmit fault (1.8.11)	20
45.2.1.7.5 Receive fault (1.8.10).....	21
45.2.1.8 PMD transmit disable register (Register 1.9).....	21
45.2.1.21 400G PMA/PMD extended ability register (Register 1.24)	22
45.2.1.21.1a1 400GBASE-LR4-6 ability (1.24.9).....	22
45.2.1.21.1a2 400GBASE-FR4 ability (1.24.8)	22
45.2.1.21b 40G/100G PMA/PMD extended ability 2 (Register 1.26)	23
45.2.1.21b.3a 100GBASE-LR1 ability (1.26.5)	23
45.2.1.21b.3b 100GBASE-FR1 ability (1.26.4)	23
78. Energy-Efficient Ethernet (EEE).....	24
78.1 Overview.....	24
78.1.4 PHY types optionally supporting EEE.....	24
80. Introduction to 40 Gb/s and 100 Gb/s networks	25
80.1 Overview.....	25
80.1.3 Relationship of 40 Gigabit and 100 Gigabit Ethernet to the ISO OSI reference model.....	25
80.1.4 Nomenclature	25
80.1.5 Physical Layer signaling systems.....	26
80.2 Summary of 40 Gigabit and 100 Gigabit Ethernet sublayers	26
80.2.3 Forward Error Correction (FEC) sublayers.....	26
80.4 Delay constraints.....	27
91. Reed-Solomon Forward Error Correction (RS-FEC) sublayer for 100GBASE-R PHYs	28
91.5 Functions within the RS-FEC sublayer	28
91.5.2.7 Reed-Solomon encoder.....	28
91.5.3 Receive function.....	28
91.5.3.3 Reed-Solomon decoder.....	28
91.5.3.3.1 FEC Degraded SER (optional).....	28
91.6 RS-FEC MDIO function mapping.....	29

91.6.2a	four_lane_pmd	29
91.7	Protocol implementation conformance statement (PICS) proforma for Clause 91, Reed-Solomon Forward Error Correction (RS-FEC) sublayer for 100GBASE-R PHYs.....	30
91.7.3	Major capabilities/options	30
91.7.4	PICS proforma tables for Reed-Solomon Forward Error Correction (RS-FEC) sublayer for 100GBASE-R PHYs	30
91.7.4.1	Transmit function	30
91.7.4.2	Receive function	31
116.	Introduction to 200 Gb/s and 400 Gb/s networks	32
116.1	Overview.....	32
116.1.2	Relationship of 200 Gigabit and 400 Gigabit Ethernet to the ISO OSI reference model.....	32
116.1.3	Nomenclature	32
116.1.4	Physical Layer signaling systems.....	33
116.4	Delay constraints.....	33
116.5	Skew constraints	34
140.	Physical Medium Dependent (PMD) sublayer and medium, type 100GBASE-DR, 100GBASE-FR1, and 100GBASE-LR1	36
140.1	Overview.....	36
140.2	Physical Medium Dependent (PMD) service interface.....	37
140.3	Delay and Skew	38
140.3.1	Delay constraints	38
140.5	PMD functional specifications.....	38
140.5.1	PMD block diagram	38
140.6	PMD to MDI optical specifications for 100GBASE-DR, 100GBASE-FR1, and 100GBASE-LR1	38
140.6.1	100GBASE-DR, 100GBASE-FR1, and 100GBASE-LR1 transmitter optical specifications	39
140.6.2	100GBASE-DR, 100GBASE-FR1, and 100GBASE-LR1 receive optical specifications	41
140.6.3	100GBASE-DR, 100GBASE-FR1, and 100GBASE-LR1 illustrative link power budgets	43
140.7	Definition of optical parameters and measurement methods.....	46
140.7.1	Test patterns for optical parameters	46
140.7.5	Transmitter and dispersion eye closure for PAM4 (TDECQ).....	46
140.7.5.1	TDECQ reference equalizer	47
140.7.5.2	Channel requirements	47
140.7.5a	Transmitter eye closure for PAM4 (TECQ).....	47
140.7.5b	Over/under-shoot.....	48
140.7.5c	Transmitter power excursion.....	48
140.7.8	Relative intensity noise (RIN _{15.5xOMA})	49
140.7.9	Receiver sensitivity	49
140.7.9.1	Receiver sensitivity for 100GBASE-DR.....	49
140.7.9.2	Receiver sensitivity for 100GBASE-FR1 and 100GBASE-LR1	49
140.7.10	Stressed receiver sensitivity	50
140.8	Safety, installation, environment, and labeling.....	50
140.8.2	Laser safety	50
140.8.4	Environment.....	50
140.8.5	Electromagnetic emission	50
140.9	Fiber optic cabling model	51

140.10	Characteristics of the fiber optic cabling (channel)	51
140.10.1	Optical fiber cable	52
140.10.2	Optical fiber connection	52
140.10.2.1	Connection insertion loss	52
140.10.2.2	Maximum discrete reflectance	52
140.10.3	Medium Dependent Interface (MDI)	53
140.10a	Interoperation between 100GBASE-DR, 100GBASE-FR1, and 100GBASE-LR1	53
140.10a.1	Interoperation between 100GBASE-FR1 and 100GBASE-DR	53
140.10a.2	Interoperation between 100GBASE-LR1 and 100GBASE-DR	54
140.10a.3	Interoperation between 100GBASE-LR1 and 100GBASE-FR1	54
140.11	Protocol implementation conformance statement (PICS) proforma for Clause 140, Physical Medium Dependent (PMD) sublayer and medium, types 100GBASE-DR, 100GBASE-FR1, and 100GBASE-LR1	55
140.11.1	Introduction	55
140.11.2	Identification	55
140.11.2.2	Protocol summary	55
140.11.3	Major capabilities/options	56
140.11.4	PICS proforma tables for Physical Medium Dependent (PMD) sublayer and medium, type 100GBASE-DR, 100GBASE-FR1, and 100GBASE-LR1	56
140.11.4.3	PMD to MDI optical specifications for 100GBASE-DR	56
140.11.4.3a	PMD to MDI optical specifications for 100GBASE-FR1	56
140.11.4.3b	PMD to MDI optical specifications for 100GBASE-LR1	57
140.11.4.4	Optical measurement methods	57
140.11.4.6	Characteristics of the fiber optic cabling and MDI	58
151.	Physical Medium Dependent (PMD) sublayer and medium, type 400GBASE-FR4 and 400GBASE-LR4-6	59
151.1	Overview	59
151.1.1	Bit error ratio	60
151.2	Physical Medium Dependent (PMD) service interface	60
151.3	Delay and Skew	61
151.3.1	Delay constraints	61
151.3.2	Skew constraints	61
151.4	PMD MDIO function mapping	62
151.5	PMD functional specifications	62
151.5.1	PMD block diagram	62
151.5.2	PMD transmit function	63
151.5.3	PMD receive function	63
151.5.4	PMD global signal detect function	64
151.5.5	PMD lane-by-lane signal detect function	64
151.5.6	PMD reset function	64
151.5.7	PMD global transmit disable function (optional)	64
151.5.8	PMD lane-by-lane transmit disable function	65
151.5.9	PMD fault function (optional)	65
151.5.10	PMD transmit fault function (optional)	65
151.5.11	PMD receive fault function (optional)	65
151.6	Wavelength-division-multiplexed lane assignments	66
151.7	PMD to MDI optical specifications for 400GBASE-FR4 and 400GBASE-LR4-6	66
151.7.1	400GBASE-FR4 and 400GBASE-LR4-6 transmitter optical specifications	66
151.7.2	400GBASE-FR4 and 400GBASE-LR4-6 receive optical specifications	68
151.7.3	400GBASE-FR4 and 400GBASE-LR4-6 illustrative link power budgets	70
151.8	Definition of optical parameters and measurement methods	72
151.8.1	Test patterns for optical parameters	72

151.8.2	Wavelength and side mode suppression ratio (SMSR).....	73
151.8.3	Average optical power	73
151.8.4	Outer Optical Modulation Amplitude (OMA _{outer}).....	73
151.8.5	Transmitter and dispersion eye closure for PAM4 (TDECQ).....	73
151.8.5.1	Channel requirements	73
151.8.6	Transmitter eye closure for PAM4 (TECQ).....	74
151.8.7	Over/under-shoot.....	74
151.8.8	Transmitter power excursion.....	74
151.8.9	Extinction ratio	74
151.8.10	Transmitter transition time.....	74
151.8.11	Relative intensity noise (RIN _{17.1OMA} and RIN _{15.6OMA})	75
151.8.12	Receiver sensitivity	75
151.8.13	Stressed receiver sensitivity	76
151.9	Safety, installation, environment, and labeling.....	76
151.9.1	General safety.....	76
151.9.2	Laser safety	76
151.9.3	Installation.....	76
151.9.4	Environment.....	77
151.9.5	Electromagnetic emission	77
151.9.6	Temperature, humidity, and handling	77
151.9.7	PMD labeling requirements	77
151.10	Fiber optic cabling model	77
151.11	Characteristics of the fiber optic cabling (channel).....	78
151.11.1	Optical fiber cable	78
151.11.2	Optical fiber connection.....	78
151.11.2.1	Connection insertion loss.....	79
151.11.2.2	Maximum discrete reflectance.....	79
151.11.3	Medium Dependent Interface (MDI) requirements	79
151.12	Interoperation between 400GBASE-LR4-6 and 400GBASE-FR4	79
151.13	Protocol implementation conformance statement (PICS) proforma for Clause 151, Physical Medium Dependent (PMD) sublayer and medium, type 400GBASE-FR4 and 400GBASE-LR4-6.....	81
151.13.1	Introduction	81
151.13.2	Identification	81
151.13.2.1	Implementation identification.....	81
151.13.2.2	Protocol summary	81
151.13.3	Major capabilities/options	82
151.13.4	PICS proforma tables for Physical Medium Dependent (PMD) sublayer and medium, type 400GBASE-FR4 and 400GBASE-LR4-6.....	82
151.13.4.1	PMD functional specifications	82
151.13.4.2	Management functions	83
151.13.4.3	PMD to MDI optical specifications for 400GBASE-FR4.....	84
151.13.4.4	PMD to MDI optical specifications for 400GBASE-LR4-6	84
151.13.4.5	Optical measurement methods.....	84
151.13.4.6	Environmental specifications	85
151.13.4.7	Characteristics of the fiber optic cabling and MDI	85

IEEE Standard for Ethernet

Amendment 11: Physical Layers and Management Parameters for 100 Gb/s and 400 Gb/s Operation over Single-Mode Fiber at 100 Gb/s per Wavelength

(This amendment is based on IEEE Std 802.3™-2018 as amended by IEEE Std 802.3cb™-2018, IEEE Std 802.3bt™-2018, IEEE Std 802.3cd™-2018, IEEE Std 802.3cn™-2019, IEEE Std 802.3cg™-2019, IEEE Std 802.3cq™-2020, IEEE Std 802.3cm™-2020, IEEE Std 802.3ch™-2020, IEEE Std 802.3ca™-2020, and IEEE Std 802.3cr™-2020.)

NOTE—The editing instructions contained in this amendment define how to merge the material contained therein into the existing base standard and its amendments to form the comprehensive standard.

The editing instructions are shown in **bold italic**. Four editing instructions are used: change, delete, insert, and replace. **Change** is used to make corrections in existing text or tables. The editing instruction specifies the location of the change and describes what is being changed by using ~~strike through~~ (to remove old material) and underscore (to add new material). **Delete** removes existing material. **Insert** adds new material without disturbing the existing material. Deletions and insertions may require renumbering. If so, renumbering instructions are given in the editing instruction. **Replace** is used to make changes in figures or equations by removing the existing figure or equation and replacing it with a new one. Editing instructions, change markings, and this NOTE will not be carried over into future editions because the changes will be incorporated into the base standard.

Cross references that refer to clauses, tables, equations, or figures not covered by this amendment are highlighted in green.¹

¹ Notes in text, tables, and figures are given for information only and do not contain requirements needed to implement the standard.

1. Introduction

1.4 Definitions

Insert the following new definition after 1.4.27 “100GBASE-ER4”:

1.4.27a 100GBASE-FR1: IEEE 802.3 Physical Layer specification for 100 Gb/s serial transmission using 100GBASE-R encoding and 4-level pulse amplitude modulation over one wavelength on single-mode fiber, with reach up to at least 2 km. (See IEEE Std 802.3, Clause 140.)

Insert the following new definition after 1.4.29 “100GBASE-KR4”:

1.4.29a 100GBASE-LR1: IEEE 802.3 Physical Layer specification for 100 Gb/s serial transmission using 100GBASE-R encoding and 4-level pulse amplitude modulation over one wavelength on single-mode fiber, with reach up to at least 10 km. (See IEEE Std 802.3, Clause 140.)

Insert the following new definition after 1.4.106a “400GBASE-ER8” as inserted by IEEE Std 802.3cn-2019:

1.4.106b 400GBASE-FR4: IEEE 802.3 Physical Layer specification for 400 Gb/s using 400GBASE-R encoding and 4-level pulse amplitude modulation over four WDM lanes on single-mode fiber, with reach up to at least 2 km. (See IEEE Std 802.3, Clause 151.)

Insert the following new definition after 1.4.107 “400GBASE-FR8”:

1.4.107a 400GBASE-LR4-6: IEEE 802.3 Physical Layer specification for 400 Gb/s using 400GBASE-R encoding and 4-level pulse amplitude modulation over four WDM lanes on single-mode fiber, with reach up to at least 6 km. (See IEEE Std 802.3, Clause 151.)

30. Management

30.5 Layer management for medium attachment units (MAUs)

30.5.1 MAU managed object class

30.5.1.1 MAU attributes

30.5.1.1.2 aMAUType

Insert 100GBASE-FR1 PHY type into the “APPROPRIATE SYNTAX” section of 30.5.1.1.2 after 100GBASE-SR10 as follows:

APPROPRIATE SYNTAX:

...	
100GBASE-FR1	100GBASE-R PCS/PMA over single-mode fiber PMD with reach up to at least 2 km as specified in Clause 140
...	

Insert 100GBASE-LR1 PHY type into the “APPROPRIATE SYNTAX” section of 30.5.1.1.2 after 100GBASE-LR4 as follows:

APPROPRIATE SYNTAX:

...	
100GBASE-LR1	100GBASE-R PCS/PMA over single-mode fiber PMD with reach up to at least 10 km as specified in Clause 140
...	

Insert 400GBASE-FR4 and 400GBASE-LR4-6 PHY types into the “APPROPRIATE SYNTAX” section of 30.5.1.1.2 after 400GBASE-FR8 as follows:

APPROPRIATE SYNTAX:

...	
400GBASE-FR4	400GBASE-R PCS/PMA over 4 WDM lane single-mode fiber PMD with reach up to at least 2 km as specified in Clause 151
400GBASE-LR4-6	400GBASE-R PCS/PMA over 4 WDM lane single-mode fiber PMD with reach up to at least 6 km as specified in Clause 151
...	

45. Management Data Input/Output (MDIO) Interface

45.2 MDIO Interface Registers

45.2.1 PMA/PMD registers

45.2.1.6 PMA/PMD control 2 register (Register 1.7)

Change the indicated reserved rows of Table 45–7 (as modified by IEEE Std 802.3cd-2018, IEEE Std 802.3cn-2019, and IEEE Std 802.3cm-2020) as follows (unchanged rows not shown):

Table 45–7—PMA/PMD control 2 register bit definitions

Bit(s)	Name	Description	R/W ^a
...			
1.7.6:0	PMA/PMD type selection	6 5 4 3 2 1 0 ... 1 1 0 0 0 1 0 = 400GBASE-LR4-6 PMA/PMDreserved 1 1 0 0 0 0 1 = 400GBASE-FR4 PMA/PMDreserved ... 1 0 0 1 1 x x = reserved 1 0 0 1 1 1 x = reserved 1 0 0 1 1 0 1 = 100GBASE-LR1 PMA/PMD 1 0 0 1 1 0 0 = 100GBASE-FR1 PMA/PMD ...	R/W

^aR/W = Read/Write, RO = Read only

45.2.1.7 PMA/PMD status 2 register (Register 1.8)

45.2.1.7.4 Transmit fault (1.8.11)

Change the row for 100GBASE-DR in Table 45–9 (as inserted by IEEE Std 802.3cd-2018) and insert a new row for 400GBASE-FR4 and 400GBASE-LR4-6 at the end of Table 45–9 as follows (unchanged rows not shown):

Table 45–9—Transmit fault description location

PMA/PMD	Description location
...	
100GBASE-DR, 100GBASE-FR1, 100GBASE-LR1	140.5.8
...	
400GBASE-FR4, 400GBASE-LR4-6	151.5.10

45.2.1.7.5 Receive fault (1.8.10)

Change the row for 100GBASE-DR in Table 45–10 (as inserted by IEEE Std 802.3cd-2018) and insert a new row for 400GBASE-FR4 and 400GBASE-LR4-6 at the end of Table 45–10 as follows (unchanged rows not shown):

Table 45–10—Receive fault description location

PMA/PMD	Description location
...	
100GBASE-DR, 100GBASE-FR1, 100GBASE-LR1	140.5.9
...	
400GBASE-FR4, 400GBASE-LR4-6	151.5.11

45.2.1.8 PMD transmit disable register (Register 1.9)

Change the row for 100GBASE-DR in Table 45–12 (as inserted by IEEE Std 802.3cd-2018) and insert a new row for 400GBASE-FR4 and 400GBASE-LR4-6 at the end of Table 45–12 as follows (unchanged rows not shown):

Table 45–12—Transmit disable description location

PMA/PMD	Description location
...	
100GBASE-DR, 100GBASE-FR1, and 100GBASE-LR1	140.5.6
...	
400GBASE-FR4 and 400GBASE-LR4-6	151.5.7

45.2.1.21 400G PMA/PMD extended ability register (Register 1.24)

Change the row for bits 1.24.9:8 in Table 45–24 (as modified by IEEE Std 802.3cm-2020) as follows (unchanged rows not shown):

Table 45–24—400G PMA/PMD extended ability register bit definitions

Bit(s)	Name	Description	R/W ^a
...			
1.24.9:8	Reserved	Value always 0	RO
1.24.9	400GBASE-LR4-6 ability	1 = PMA/PMD is able to perform 400GBASE-LR4-6 0 = PMA/PMD is not able to perform 400GBASE-LR4-6	RO
1.24.8	400GBASE-FR4 ability	1 = PMA/PMD is able to perform 400GBASE-FR4 0 = PMA/PMD is not able to perform 400GBASE-FR4	RO
...			

^aRO = Read only

Insert 45.2.1.21.1a1 and 45.2.1.21.1a2 after 45.2.1.21.1a (as inserted by IEEE Std 802.3cn-2019) and before 45.2.1.21.1b (as inserted by IEEE Std 802.3cm-2020) as follows:

45.2.1.21.1a1 400GBASE-LR4-6 ability (1.24.9)

When read as a one, bit 1.24.9 indicates that the PMA/PMD is able to operate as a 400GBASE-LR4-6 PMA/PMD type. When read as a zero, bit 1.24.9 indicates that the PMA/PMD is not able to operate as a 400GBASE-LR4-6 PMA/PMD type.

45.2.1.21.1a2 400GBASE-FR4 ability (1.24.8)

When read as a one, bit 1.24.8 indicates that the PMA/PMD is able to operate as a 400GBASE-FR4 PMA/PMD type. When read as a zero, bit 1.24.8 indicates that the PMA/PMD is not able to operate as a 400GBASE-FR4 PMA/PMD type.

45.2.1.21b 40G/100G PMA/PMD extended ability 2 (Register 1.26)

Change the row for bits 1.26.6:4 in Table 45–24b (as inserted by IEEE Std 802.3cn-2019) as follows (unchanged rows not shown):

Table 45–24b—40G/100G PMA/PMD extended ability 2 register bit definitions

Bit(s)	Name	Description	R/W ^a
...			
1.26.6:4 1.26.6	Reserved	Value always 0	RO
1.26.5	100GBASE-LR1 ability	1 = PMA/PMD is able to perform 100GBASE-LR1 0 = PMA/PMD is not able to perform 100GBASE-LR1	RO
1.26.4	100GBASE-FR1 ability	1 = PMA/PMD is able to perform 100GBASE-FR1 0 = PMA/PMD is not able to perform 100GBASE-FR1	RO
...			

^aRO = Read only

Insert 45.2.1.21b.3a and 45.2.1.21b.3b after 45.2.1.21b.3 (as inserted by IEEE Std 802.3cn-2019) as follows:

45.2.1.21b.3a 100GBASE-LR1 ability (1.26.5)

When read as a one, bit 1.26.5 indicates that the PMA/PMD is able to operate as a 100GBASE-LR1 PMA/PMD type. When read as a zero, bit 1.26.5 indicates that the PMA/PMD is not able to operate as a 100GBASE-LR1 PMA/PMD type.

45.2.1.21b.3b 100GBASE-FR1 ability (1.26.4)

When read as a one, bit 1.26.4 indicates that the PMA/PMD is able to operate as a 100GBASE-FR1 PMA/PMD type. When read as a zero, bit 1.26.4 indicates that the PMA/PMD is not able to operate as a 100GBASE-FR1 PMA/PMD type.

78. Energy-Efficient Ethernet (EEE)

78.1 Overview

78.1.4 PHY types optionally supporting EEE

Insert new rows for 100GBASE-FR1, 100GBASE-LR1, 400GBASE-FR4, and 400GBASE-LR4-6 in Table 78–1 (as modified by IEEE Std 802.3cd-2018) with 100GBASE-FR1 after 100GBASE-DR, 100GBASE-LR1 after 100GBASE-LR4, and 400GBASE-FR4 and 400GBASE-LR4-6 after 400GBASE-FR8 as follows (unchanged rows not shown):

Table 78–1—Clauses associated with each PHY or interface type

PHY or interface type	Clause
...	
100GBASE-FR1 ^b	82, 135, 140
...	
100GBASE-LR1 ^b	82, 135, 140
...	
400GBASE-FR4 ^b	119, 120, 151
400GBASE-LR4-6 ^b	119, 120, 151
...	

^b The deep sleep mode of EEE is not supported for this PHY.

STANDARDSISO.COM : Click to view the full PDF of ISO/IEC/IEEE 8802-3:2021/Amd 11:2022

80. Introduction to 40 Gb/s and 100 Gb/s networks

80.1 Overview

80.1.3 Relationship of 40 Gigabit and 100 Gigabit Ethernet to the ISO OSI reference model

Change list item h) in 80.1.3 (as changed by IEEE Std 802.3cd-2018) as follows:

- h) The MDIs as specified in [Clause 89](#) for 40GBASE-FR, and [in](#) [Clause 140](#) for 100GBASE-DR, 100GBASE-FR1, and 100GBASE-LR1 use a single lane data path.

80.1.4 Nomenclature

Insert new rows for 100GBASE-FR1, and 100GBASE-LR1 in [Table 80–1](#) (as changed by IEEE Std 802.3cd-2018), with 100GBASE-FR1 after 100GBASE-DR, and 100GBASE-LR1 after 100GBASE-LR4 as follows (unchanged rows not shown):

Table 80–1—40 Gb/s and 100 Gb/s PHYs

Name	Description
...	
100GBASE-FR1	100 Gb/s PHY using 100GBASE-R encoding over single-mode fiber, with reach up to at least 2 km (see Clause 140)
...	
100GBASE-LR1	100 Gb/s PHY using 100GBASE-R encoding over single-mode fiber, with reach up to at least 10 km (see Clause 140)
...	

80.1.5 Physical Layer signaling systems

Change Table 80–4a (as inserted by IEEE Std 802.3cd-2018) as follows:

Table 80–4a—Nomenclature and clause correlation (100GBASE-P optical)

Nomenclature	Clause ^a																			
	78	81	82	83	83A	83B	83D	83E	91	135	135D	135E	135F	135G	138	140				
	EEE	RS	CGMII	PCS	100GBASE-R PMA	CAUI-10	CAUI-10	CAUI-4	CAUI-4	RS-FEC	100GBASE-P PMA	100GAUI-4 C2C	100GAUI-4 C2M	100GAUI-2 C2C	100GAUI-2 C2M	100GBASE-SR2	100GBASE-DR	100GBASE-FR1	100GBASE-LR1	
100GBASE-SR2	O	M	O	M	O	O	O	O	O	M	M	O	O	O	O	M				
100GBASE-DR	O	M	O	M	O	O	O	O	O	M	M	O	O	O	O		M			
100GBASE-FR1	<u>O</u>	<u>M</u>	<u>O</u>	<u>M</u>	<u>O</u>	<u>O</u>	<u>O</u>	<u>O</u>	<u>O</u>	<u>M</u>	<u>M</u>	<u>O</u>	<u>O</u>	<u>O</u>	<u>O</u>				<u>M</u>	
100GBASE-LR1	<u>O</u>	<u>M</u>	<u>O</u>	<u>M</u>	<u>O</u>	<u>O</u>	<u>O</u>	<u>O</u>	<u>O</u>	<u>M</u>	<u>M</u>	<u>O</u>	<u>O</u>	<u>O</u>	<u>O</u>					<u>M</u>

^aO = Optional, M = Mandatory.

80.2 Summary of 40 Gigabit and 100 Gigabit Ethernet sublayers

80.2.3 Forward Error Correction (FEC) sublayers

Change the first paragraph in 80.2.3 (as changed by IEEE Std 802.3cd-2018) as follows:

A Forward Error Correction sublayer is optional for 40GBASE-KR4, 40GBASE-CR4, and 100GBASE-CR10 PHYs and mandatory for 100GBASE-CR2, 100GBASE-CR4, 100GBASE-KR2, 100GBASE-KR4, 100GBASE-KP4, 100GBASE-SR2, 100GBASE-SR4, and 100GBASE-DR, 100GBASE-FR1, and 100GBASE-LR1 PHYs. The FEC sublayer can be placed in between the PCS and PMA sublayers or between two PMA sublayers.

80.4 Delay constraints

Insert new rows for 100GBASE-FR1, and 100GBASE-LR1 in Table 80–5 (as changed by IEEE Std 802.3cd-2018), with 100GBASE-FR1 after 100GBASE-DR, and 100GBASE-LR1 after 100GBASE-LR4 as follows (unchanged rows not shown):

Table 80–5—Sublayer delay constraints

Sublayer	Maximum (bit time) ^a	Maximum (pause_quanta) ^b	Maximum (ns)	Notes ^c
...				
100GBASE-FR1 PMD	2 048	4	20.48	Includes 2 m of fiber. See 140.3.
...				
100GBASE-LR1 PMD	2 048	4	20.48	Includes 2 m of fiber. See 140.3.
...				

^a For 40GBASE-R, 1 bit time (BT) is equal to 25 ps and for 100GBASE-R, 1 bit time (BT) is equal to 10 ps. (See 1.4.160 for the definition of bit time.)

^b For 40GBASE-R, 1 pause_quantum is equal to 12.8 ns and for 100GBASE-R, 1 pause_quantum is equal to 5.12 ns. (See 31B.2 for the definition of pause_quanta.)

^c Should there be a discrepancy between this table and the delay requirements of the relevant sublayer clause, the sublayer clause prevails.

STANDARDSISO.COM : Click to view the full PDF of ISO/IEC/IEEE 8802-3:2021/Amd 11:2022

91. Reed-Solomon Forward Error Correction (RS-FEC) sublayer for 100GBASE-R PHYs

91.5 Functions within the RS-FEC sublayer

91.5.2.7 Reed-Solomon encoder

Change the second sentence of the second paragraph of 91.5.2.7 (as changed by IEEE Std 802.3cd-2018) as follows:

When used to form a 100GBASE-KP4, 100GBASE-CR2, 100GBASE-KR2, 100GBASE-SR2, ~~or~~ 100GBASE-DR, 100GBASE-FR1, or 100GBASE-LR1 PHY, the RS-FEC sublayer shall implement RS(544,514).

91.5.3 Receive function

91.5.3.3 Reed-Solomon decoder

Change the second sentence of the second paragraph of 91.5.3.3 (as changed by IEEE Std 802.3cd-2018) as follows:

When used to form a 100GBASE-KP4, 100GBASE-CR2, 100GBASE-KR2, 100GBASE-SR2, ~~or~~ 100GBASE-DR, 100GBASE-FR1, or 100GBASE-LR1 PHY, the RS-FEC sublayer shall be capable of correcting any combination of up to $t=15$ symbol errors in a codeword.

Change the last sentence of the third paragraph of 91.5.3.3 (as changed by IEEE Std 802.3cd-2018) as follows:

This option shall not be used when the RS-FEC sublayer is used to form part of a 100GBASE-CR2, 100GBASE-KR2, 100GBASE-SR2, 100GBASE-SR4, ~~or~~ 100GBASE-DR, 100GBASE-FR1, or 100GBASE-LR1 PHY.

Change the last sentence of the last paragraph of 91.5.3.3 (as changed by IEEE Std 802.3cd-2018) as follows:

When the RS-FEC sublayer is used to form a 100GBASE-KP4, 100GBASE-CR2, 100GBASE-KR2, 100GBASE-SR2, ~~or~~ 100GBASE-DR, 100GBASE-FR1, or 100GBASE-LR1 PHY, the symbol error threshold shall be $K=6380$.

91.5.3.3.1 FEC Degraded SER (optional)

Change the first paragraph of 91.5.3.3.1 (as inserted by IEEE Std 802.3cd-2018) as follows:

For 100GBASE-CR2, 100GBASE-KR2, 100GBASE-SR2, ~~and~~ 100GBASE-DR, 100GBASE-FR1, and 100GBASE-LR1 PHYs an optional FEC degraded symbol error ratio function is available.

91.6 RS-FEC MDIO function mapping

91.6.2a four_lane_pmd

Change 91.6.2a (as inserted by IEEE Std 802.3cd-2018) as follows:

When this variable is set to one, the alignment marker mapping function substitutes the fixed bytes of the alignment markers corresponding to PCS lanes 17, 18, and 19 with the fixed bytes for the alignment marker corresponding to PCS lane 16 (see 91.5.2.6). When this variable is set to zero, the alignment markers corresponding to PCS lanes 17, 18, and 19 are passed through unmodified. The default value of the variable is one which is the value required by the 100GBASE-CR4, 100GBASE-KR4, 100GBASE-KP4, and 100GBASE-SR4 PMDs. This variable is set to zero for the 100GBASE-CR2, 100GBASE-KR2, 100GBASE-SR2, ~~and 100GBASE-DR, 100GBASE-FR1, and 100GBASE-LR1~~ PMDs. This variable is mapped to the bit defined in 45.2.1.110 (1.200.3).

91.7 Protocol implementation conformance statement (PICS) proforma for Clause 91, Reed-Solomon Forward Error Correction (RS-FEC) sublayer for 100GBASE-R PHYs³

91.7.3 Major capabilities/options

Change the rows for items *KP4 and *FDDP in the table in 91.7.3 (as changed by IEEE Std 802.3cd-2018) as follows (unchanged rows not shown):

Item	Feature	Subclause	Value/Comment	Status	Support
...					
*KP4	100GBASE-KP4, 100GBASE-CR2, 100GBASE-KR2, 100GBASE-SR2, or 100GBASE-DR, <u>100GBASE-FR1, or</u> <u>100GBASE-LR1</u>		Used to form complete 100GBASE-KP4, 100GBASE-CR2, 100GBASE-KR2, 100GBASE-SR2, or 100GBASE-DR, <u>100GBASE-FR1, or</u> <u>100GBASE-LR1</u> PHY	O	Yes [] No []
*FDDP	100GBASE-CR2, 100GBASE-KR2, 100GBASE-SR2, or 100GBASE-DR, <u>100GBASE-FR1, or</u> <u>100GBASE-LR1</u>	91.5.3.3.1	Used to form complete 100GBASE-CR2, 100GBASE-KR2, 100GBASE-SR2, or 100GBASE-DR, <u>100GBASE-FR1, or</u> <u>100GBASE-LR1</u> PHY	O	Yes [] No []
...					

91.7.4 PICS proforma tables for Reed-Solomon Forward Error Correction (RS-FEC) sublayer for 100GBASE-R PHYs

91.7.4.1 Transmit function

Change the row for item TF11 in the table in 91.7.4.1 (as changed by IEEE Std 802.3cd-2018) as follows (unchanged rows not shown):

Item	Feature	Subclause	Value/Comment	Status	Support
...					
TF11	Reed-Solomon encoder for 100GBASE-KP4, 100GBASE-CR2, 100GBASE-KR2, 100GBASE-SR2, or 100GBASE-DR, <u>100GBASE-FR1, or</u> <u>100GBASE-LR1</u>	91.5.2.7	RS(544,514)	KP4:M	Yes [] N/A []
...					

³ Copyright release for PICS proformas: Users of this standard may freely reproduce the PICS proforma in this subclause so that it can be used for its intended purpose and may further publish the completed PICS.

91.7.4.2 Receive function

Change the rows for items RF4, RF6, and RF12 in the table in 91.7.4.2 (as changed by IEEE Std 802.3cd-2018) as follows (unchanged rows not shown):

Item	Feature	Subclause	Value/Comment	Status	Support
...					
RF4	Reed-Solomon decoder for 100GBASE-KP4, 100GBASE-CR2, 100GBASE-KR2, 100GBASE-SR2, or 100GBASE-DR, <u>100GBASE-FR1, or 100GBASE-LR1</u>	91.5.3.3	Corrects any combination of up to $t=15$ symbol errors in a codeword unless error correction bypassed	KP4:M	Yes [] N/A []
...					
RF6	Error correction bypass for 100GBASE-CR2, 100GBASE-KR2, 100GBASE-SR2, 100GBASE-SR4, or 100GBASE-DR, <u>100GBASE-FR1, or 100GBASE-LR1</u>	91.5.3.3	Error correction is not bypassed	SR4:M or FDDP:M	Yes [] N/A []
...					
RF12	Symbol error threshold for 100GBASE-KP4, 100GBASE-CR2, 100GBASE-KR2, 100GBASE-SR2, or 100GBASE-DR, <u>100GBASE-FR1, or 100GBASE-LR1</u>	91.5.3.3	$K=6380$	BEI* KP4:M	Yes [] N/A []
...					

116. Introduction to 200 Gb/s and 400 Gb/s networks

116.1 Overview

116.1.2 Relationship of 200 Gigabit and 400 Gigabit Ethernet to the ISO OSI reference model

Change item h) in the lettered list in 116.1.2 (as changed by IEEE Std 802.3cd-2018 and IEEE Std 802.3cn-2019) as follows:

- h) The MDIs as specified in Clause 121 for 200GBASE-DR4, in Clause 122 for 200GBASE-FR4, 200GBASE-LR4, and 200GBASE-ER4, ~~and in Clause 124~~ for 400GBASE-DR4, in Clause 136 for 200GBASE-CR4, in Clause 137 for 200GBASE-KR4, ~~and in Clause 138~~ for 200GBASE-SR4, and in Clause 151 for 400GBASE-FR4 and 400GBASE-LR4-6, all use a 4-lane data path.

116.1.3 Nomenclature

Insert two new rows for 400GBASE-FR4 and 400GBASE-LR4-6 in Table 116-2 after 400GBASE-FR8 as follows (unchanged rows not shown):

Table 116-2—400 Gb/s PHYs

Name	Description
...	
400GBASE-FR4	400 Gb/s PHY using 400GBASE-R encoding over four WDM lanes on single-mode fiber, with reach up to at least 2 km (see Clause 151)
400GBASE-LR4-6	400 Gb/s PHY using 400GBASE-R encoding over four WDM lanes on single-mode fiber, with reach up to at least 6 km (see Clause 151)
...	

116.1.4 Physical Layer signaling systems

Change Table 116–4 (as modified by IEEE Std 802.3cm-2020) as follows:

Table 116–4—PHY type and clause correlation (400GBASE optical)

PHY type	Clause ^a																			
	78	117	118	119	120	120B	120C	120D	120E	123	138	150	124	122	151	122				
	EEE	RS	400GMII	400GMII Extender	400GBASE-R PCS	400GBASE-R PMA	400GAUI-16 C2C	400GAUI-16 C2M	400GAUI-8 C2C	400GAUI-8 C2M	400GBASE-SR16 PMD	400GBASE-SR8 PMD	400GBASE-SR4.2 PMD	400GBASE-DR4 PMD	400GBASE-FR8 PMD	400GBASE-FR4 PMD	400GBASE-LR4-6 PMD	400GBASE-LR8 PMD	400GBASE-ER8 PMD	
400GBASE-SR16	O	M	O	O	M	M	O	O	O	O	M									
400GBASE-SR8	O	M	O	O	M	M	O	O	O	O		M								
400GBASE-SR4.2	O	M	O	O	M	M	O	O	O	O			M							
400GBASE-DR4	O	M	O	O	M	M	O	O	O	O				M						
400GBASE-FR8	O	M	O	O	M	M	O	O	O	O					M					
400GBASE-FR4	O	M	O	O	M	M	O	O	O	O						M				
400GBASE-LR4-6	O	M	O	O	M	M	O	O	O	O							M			
400GBASE-LR8	O	M	O	O	M	M	O	O	O	O									M	
400GBASE-ER8	O	M	O	O	M	M	O	O	O	O										M

^a O = Optional, M = Mandatory.

116.4 Delay constraints

Insert two new rows for 400GBASE-FR4 and 400GBASE-LR4-6 in Table 116–6 after 400GBASE-FR8 as follows (unchanged rows not shown):

Table 116–6—Sublayer delay constraints (400GBASE)

Sublayer	Maximum (bit time) ^a	Maximum (pause_quantum) ^b	Maximum (ns)	Notes ^c
400GBASE-FR4 PMD	8 192	16	20.48	Includes 2 m of fiber. See 151.3.1.
400GBASE-LR4-6 PMD	8 192	16	20.48	Includes 2 m of fiber. See 151.3.1.
...				

^a For 400GBASE-R, 1 bit time (BT) is equal to 2.5 ps. (See 1.4.160 for the definition of bit time.)

^b For 400GBASE-R, 1 pause_quantum is equal to 1.28 ns. (See 31B.2 for the definition of pause_quantum.)

^c Should there be a discrepancy between this table and the delay requirements of the relevant sublayer clause, the sublayer clause prevails.

116.5 Skew constraints

Change Table 116–7 (as changed by IEEE Std 802.3cm-2020) as follows:

Table 116–7—Summary of Skew constraints

Skew points	Maximum Skew (ns) ^a	Maximum Skew for 200GBASE-R or 400GBASE-R PCS lane (UI) ^b	Notes ^c
SP1	29	≈ 770	See 120.5.3.1
SP2	43	≈ 1142	See 120.5.3.3, 121.3.2, 122.3.2, 123.3.2, 124.3.2, 138.3.2, or 150.3.2, <u>or 151.3.2</u>
SP3	54	≈ 1434	See 121.3.2, 122.3.2, 123.3.2, 124.3.2, 138.3.2, or 150.3.2, <u>or 151.3.2</u>
SP4	134	≈ 3559	See 121.3.2, 122.3.2, 123.3.2, 124.3.2, 138.3.2, or 150.3.2, <u>or 151.3.2</u>
SP5	145	≈ 3852	See 121.3.2, 122.3.2, 123.3.2, 124.3.2, 138.3.2, or 150.3.2, <u>or 151.3.2</u>
SP6	160	≈ 4250	See 120.5.3.5
At PCS receive	180	≈ 4781	See 119.2.5.1

^a The Skew limit includes 1 ns allowance for PCB traces that are associated with the Skew points.

^b The symbol ≈ indicates approximate equivalent of maximum Skew in UI based on 1 UI equals 37.64706 ps at PCS lane signaling rate of 26.5625 GBd.

^c Should there be a discrepancy between this table and the Skew requirements of the relevant sublayer clause, the sublayer clause prevails.

Change Table 116–8 (as changed by IEEE Std 802.3cm-2020) as follows:

Table 116–8—Summary of Skew Variation constraints

Skew points	Maximum Skew Variation (ns)	Maximum Skew Variation for 26.5625 GBd PMD lane (UI) ^a	Maximum Skew Variation for 53.125 GBd PMD lane (UI) ^b	Notes ^c
SP1	0.2	≈ 5	N/A	See 120.5.3.1
SP2	0.4	≈11	» 21	See 120.5.3.3, 121.3.2, 122.3.2, 123.3.2, 124.3.2, 138.3.2, or 150.3.2, or 151.3.2
SP3	0.6	≈ 16	» 32	See 121.3.2, 122.3.2, 123.3.2, 124.3.2, 138.3.2, or 150.3.2, or 151.3.2
SP4	3.4	≈ 90	» 181	See 121.3.2, 122.3.2, 123.3.2, 124.3.2, 138.3.2, or 150.3.2, or 151.3.2
SP5	3.6	≈ 96	» 191	See 121.3.2, 122.3.2, 123.3.2, 124.3.2, 138.3.2, or 150.3.2, or 151.3.2
SP6	3.8	≈ 101	N/A	See 120.5.3.5
At PCS receive	4	≈ 106	N/A	See 119.2.5.1

^a The symbol ≈ indicates approximate equivalent of maximum Skew Variation in UI based on 1 UI equals 37.64706 ps at PMD lane signaling rate of 26.5625 GBd.

^b The symbol ≈ indicates approximate equivalent of maximum Skew Variation in UI based on 1 UI equals 18.82353 ps at PMD lane signaling rate of 53.125 GBd.

^c Should there be a discrepancy between this table and the Skew requirements of the relevant sublayer clause, the sublayer clause prevails.

Clause 140 was added to IEEE Std 802.3-2018 by IEEE Std 802.3cd-2018.

Change the title of Clause 140 as follows:

**140. Physical Medium Dependent (PMD) sublayer and medium, type
 100GBASE-DR, 100GBASE-FR1, and 100GBASE-LR1**

140.1 Overview

Change the first two sentences of the first paragraph of 140.1 as follows:

This clause specifies the 100GBASE-DR, 100GBASE-FR1, and the 100GBASE-LR1 PMDs together with the single-mode fiber medium. The optical signals generated by ~~the~~ these PMD types ~~is~~ are modulated using a 4-level pulse amplitude modulation (PAM4) format.

Change Table 140–1 title, heading row, and footnote as follows:

Table 140–1—Physical Layer clauses associated with the 100GBASE-DR, 100GBASE-FR1, and 100GBASE-LR1 PMDs

Associated clause	100GBASE-DR, 100GBASE-FR1, 100GBASE-LR1
81—RS	Required
81—100GMII ^a	Optional
82—PCS	Required
83—100GBASE-R PMA	Optional
91—RS-FEC	Required
83A—CAUI-10 C2C	Optional
83B—CAUI-10 C2M	Optional
83D—CAUI-4 C2C	Optional
83E—CAUI-4 C2M	Optional
135—100GBASE-P PMA	Required
135D—100GAUI-4 C2C	Optional
135E—100GAUI-4 C2M	Optional
135F—100GAUI-2 C2C	Optional
135G—100GAUI-2 C2M	Optional
78—Energy-Efficient Ethernet	Optional

^a The 100GMII is an optional interface. However, if the 100GMII is not implemented, a conforming implementation ~~must~~ behaves functionally as though the RS and 100GMII were present.

Change the third paragraph of 140.1 as follows:

100GBASE-DR, 100GBASE-FR1, and 100GBASE-LR1 PHYs with the optional Energy-Efficient Ethernet (EEE) fast wake capability may enter the Low Power Idle (LPI) mode to conserve energy during periods of low link utilization (see Clause 78). The deep sleep mode of EEE is not supported.

Replace Figure 140–1 and change the title as follows:

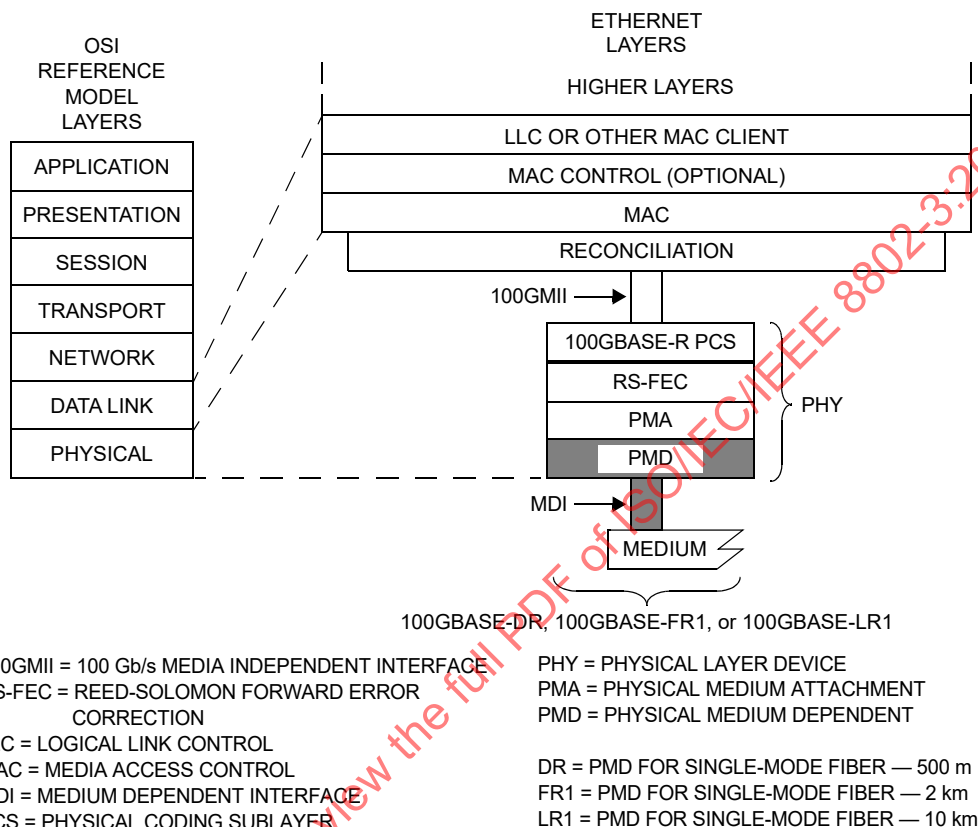

Figure 140–1—100GBASE-DR, 100GBASE-FR1, and 100GBASE-LR1 PMD relationship to the ISO/IEC Open Systems Interconnection (OSI) reference model and IEEE 802.3 Ethernet model

140.2 Physical Medium Dependent (PMD) service interface

Change the first two paragraphs of 140.2 as follows:

This subclause specifies the services provided by the 100GBASE-DR, 100GBASE-FR1, or 100GBASE-LR1 PMD. The service interface for this PMD is described in an abstract manner and does not imply any particular implementation. The PMD service interface supports the exchange of encoded data between the PMA entity that resides just above the PMD, and the PMD entity. The PMD translates the encoded data to and from signals suitable for the specified medium.

The 100GBASE-DR, 100GBASE-FR1, or 100GBASE-LR1 PMD service interface is an instance of the inter-sublayer service interface defined in 116.3, with a single symbol stream ($n = 1$).

140.3 Delay and Skew

140.3.1 Delay constraints

Change 140.3.1 as follows:

The sum of the transmit and receive delays at one end of the link contributed by the 100GBASE-DR, 100GBASE-FR1, or 100GBASE-LR1 PMD including 2 m of fiber in one direction shall be no more than 2048 bit times (4 pause_quanta or 20.48 ns). A description of overall system delay constraints and the definitions for bit times and pause_quanta can be found in 80.4 and its references.

140.5 PMD functional specifications

Change 140.5 as follows:

The 100GBASE-DR, 100GBASE-FR1, or 100GBASE-LR1 PMD performs the Transmit and Receive functions, which convey data between the PMD service interface and the MDI.

140.5.1 PMD block diagram

Change the title of Figure 140–2 as follows:

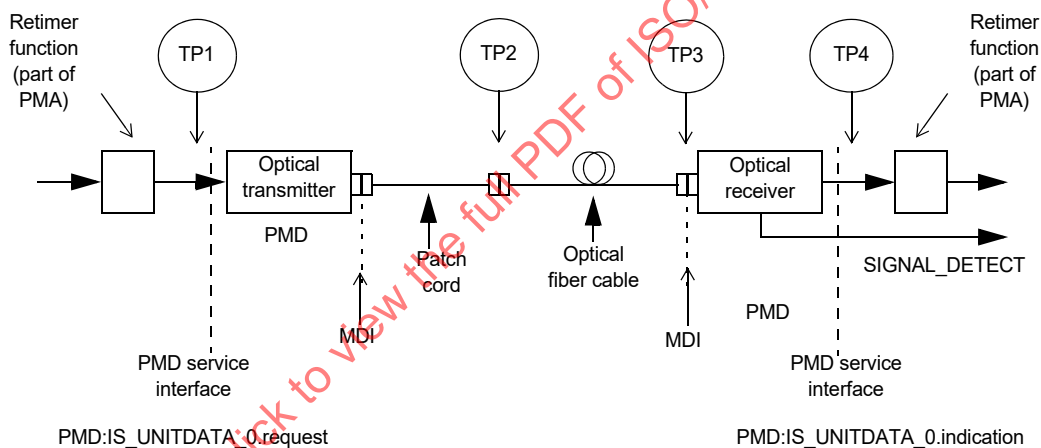

For clarity, only one direction of transmission is shown

Figure 140–2—Block diagram for 100GBASE-DR, 100GBASE-FR1, or 100GBASE-LR1 transmit/receive paths

Change the title and content of 140.6 as follows:

140.6 PMD to MDI optical specifications for 100GBASE-DR, 100GBASE-FR1, and 100GBASE-LR1

The operating ranges for the 100GBASE-DR, 100GBASE-FR1, and 100GBASE-LR1 PMDs ~~is~~ are defined in Table 140–5. A 100GBASE-DR, 100GBASE-FR1, or 100GBASE-LR1 compliant PMD operates on type B1.1, B1.3, or B6 single-mode fibers according to the specifications defined in Table 140–13. A PMD that exceeds the operating range requirement while meeting all other optical specifications is considered

compliant (e.g., a 100GBASE-DR PMD operating at 600 m meets the operating range requirement of 2 m to 500 m).

The 100GBASE-FR1 PMD interoperates with the 100GBASE-DR PMD provided that the channel and power guidelines in 140.10a.1 are met.

The 100GBASE-LR1 PMD interoperates with the 100GBASE-DR PMD provided that the channel guidelines in 140.10a.2 are met.

The 100GBASE-LR1 PMD interoperates with the 100GBASE-FR1 PMD provided that the channel guidelines in 140.10a.3 are met.

Table 140–5—100GBASE-DR, 100GBASE-FR1, and 100GBASE-LR1 operating ranges

PMD type	Required operating range
100GBASE-DR	2 m to 500 m
<u>100GBASE-FR1</u>	<u>2 m to 2 km</u>
<u>100GBASE-LR1</u>	<u>2 m to 10 km</u>

Change the title and content of 140.6.1 as follows:

140.6.1 100GBASE-DR, 100GBASE-FR1, and 100GBASE-LR1 transmitter optical specifications

The 100GBASE-DR, 100GBASE-FR1, or 100GBASE-LR1 transmitter shall meet the specifications defined in Table 140–6 per the definitions in 140.7.

Table 140–6—100GBASE-DR, 100GBASE-FR1, and 100GBASE-LR1 transmit characteristics

Description	Value			Unit
	<u>100GBASE-DR</u>	<u>100GBASE-FR1</u>	<u>100GBASE-LR1</u>	
Signaling rate (range)	53.125 ± 100 ppm			Gbd
Modulation format	PAM4			—
Wavelength (range)	1304.5 to 1317.5			nm
Side-mode suppression ratio (SMSR), (min)	30			dB
Average launch power (max)	4	<u>4</u>	<u>4.8</u>	dBm
Average launch power ^a (min)	-2.9	<u>-3.1</u>	<u>-1.9</u>	dBm
Outer Optical Modulation Amplitude (OMA _{outer}) (max)	4.2	<u>4.2</u>	<u>5</u>	dBm
Outer Optical Modulation Amplitude (OMA _{outer}) (min) ^b	-0.8	—	—	dBm
for TDECQ ≤ 1.4 dB	—	<u>-0.1</u>	<u>1.1</u>	<u>dBm</u>
for 1.4 dB ≤ TDECQ ≤ 3.4 dB	—	<u>-1.5 + TDECQ</u>	<u>-0.3 + TDECQ</u>	<u>dBm</u>

**Table 140–6—100GBASE-DR, 100GBASE-FR1, and 100GBASE-LR1 transmit characteristics
 (continued)**

Description	Value 100GBASE-DR	100GBASE-FR1	100GBASE-LR1	Unit
Launch power in OMA_{outer} minus TDECQ (min): for extinction ratio ≥ 5 dB for extinction ratio < 5 dB	-2.2 -1.9	= =	= =	dBm dBm
Transmitter and dispersion eye closure for PAM4 (TDECQ) (max)	3.4	<u>3.4</u>	<u>3.4</u>	dB
TDECQ - $10\log_{10}(C_{eq})^c$ (max)	3.4	=	=	dB
Average launch power of OFF-transmitter (max)	-15			dBm
Transmitter eye closure for PAM4 (TECQ) (max)	=	<u>3.4</u>	<u>3.4</u>	dB
TDECQ - TECQ (max)	=	<u>2.5</u>	<u>2.5</u>	dB
Over/under-shoot (max)	=	<u>22</u>	<u>22</u>	%
Transmitter power excursion (max)	=	<u>2</u>	<u>2.8</u>	dBm
Extinction ratio (min)	3.5	<u>3.5</u>	<u>3.5</u>	dB
Transmitter transition time (max)	17	<u>17</u>	<u>17</u>	ps
Average launch power of OFF-transmitter (max)	-15	-15	-15	dBm
$RIN_{15.5,OMA}$ (max) $RIN_{x,OMA}$ (max), where x is the optical return loss tolerance (max)	-136	-136	-136	dB/Hz
Optical return loss tolerance (max)	15.5	<u>17.1</u>	<u>15.6</u>	dB
Transmitter reflectance ^d (max)	-26	<u>-26</u>	<u>-26</u>	dB

^a Average launch power (min) is informative and not the principal indicator of signal strength. A transmitter with launch power below this value cannot be compliant; however, a value above this does not ensure compliance.

^b For 100GBASE-DR, the requirement on the OMA_{outer} (min) applies even in the cases where $TDECQ < 1.4$ dB for an extinction ratio of ≥ 5 dB or where $TDECQ < 1.1$ dB for an extinction ratio of < 5 dB, the OMA_{outer} (min) must exceed this value.

^c C_{eq} is a coefficient defined in 121.8.5.3, which accounts for the reference equalizer noise enhancement.

^d Transmitter reflectance is defined looking into the transmitter.

Insert new text and Figure 140–2a at the end of 140.6.1 as follows:

The values for OMA_{outer} (min) in Table 140–6 vary with TDECQ. Figure 140–2a illustrates this for 100GBASE-FR1 and 100GBASE-LR1, along with the values for OMA_{outer} (max).

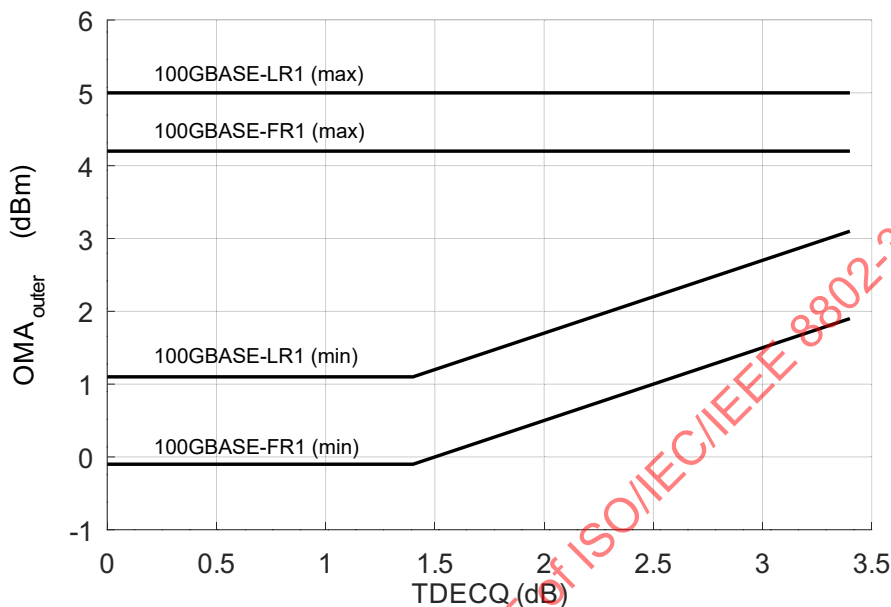

Figure 140–2a— OMA_{outer} (max) and OMA_{outer} (min) versus TDECQ for 100GBASE-FR1 and 100GBASE-LR1

Change the title and content of 140.6.2 as follows:

140.6.2 100GBASE-DR, 100GBASE-FR1, and 100GBASE-LR1 receive optical specifications

The 100GBASE-DR, 100GBASE-FR1, or 100GBASE-LR1 receiver shall meet the specifications defined in Table 140–7 per the definitions in 140.7.

Table 140–7—100GBASE-DR, 100GBASE-FR1, and 100GBASE-LR1 receive characteristics

Description	Value 100GBASE-DR	100GBASE-FR1	100GBASE-LR1	Unit
Signaling rate (range)	53.125 ± 100 ppm			GBd
Modulation format	PAM4			—
Wavelengths (range)	1304.5 to 1317.5			nm
Damage threshold ^a	5	<u>5</u>	<u>5.8</u>	dBm
Average receive power (max)	4	<u>4</u>	<u>4.8</u>	dBm
Average receive power ^b (min)	–5.9	<u>–7.1</u>	<u>–8.2</u>	dBm
Receive power (OMA _{outer}) (max)	4.2	<u>4.2</u>	<u>5</u>	dBm
Receiver reflectance (max)	–26	<u>–26</u>	<u>–26</u>	dB
Receiver sensitivity (OMA _{outer}) ^e (max)	Equation (140–1) ^c	<u>—</u>	<u>—</u>	dBm
for TECQ < 1.4 dB	<u>—</u>	<u>–4.5</u>	<u>–6.1</u>	<u>dBm</u>
for 1.4 dB ≤ TECQ ≤ 3.4 dB	<u>—</u>	<u>–5.9 + TECQ</u>	<u>–7.5 + TECQ</u>	<u>dBm</u>
Stressed receiver sensitivity (OMA _{outer}) ^d (max)	–1.9	<u>–2.5</u>	<u>–4.1</u>	dBm
Conditions of stressed receiver sensitivity test: ^e				
Stressed eye closure for PAM4 (SECQ)	3.4	<u>3.4</u>	<u>3.4</u>	dB
SECQ – 10log ₁₀ (C _{eq}) ^f (max)	3.4	<u>—</u>	<u>—</u>	dB

^a The receiver shall be able to tolerate, without damage, continuous exposure to an optical input signal having this average power level. The receiver does not have to operate correctly at this input power.

^b Average receive power (min) is informative and not the principal indicator of signal strength. A received power below this value cannot be compliant; however, a value above this does not ensure compliance.

^c Receiver sensitivity (OMA_{outer}) (max) for 100GBASE-DR is informative and is defined for a transmitter with a value of SECQ up to 3.4 dB.

^d Measured with conformance test signal at TP3 (see 140.7.10) for the BER specified in 140.1.1.

^e These test conditions are for measuring stressed receiver sensitivity. They are not characteristics of the receiver.

^f C_{eq} is a coefficient defined in 121.8.5.3, which accounts for the reference equalizer noise enhancement.

Insert new text and Figure 140–2b at the end of 140.6.2 as follows:

The values for receiver sensitivity (OMA_{outer}) (max) in Table 140–7 vary depending on the value of TECQ of the test source used for measurement. Figure 140–2b illustrates this for 100GBASE-FR1 and 100GBASE-LR1.

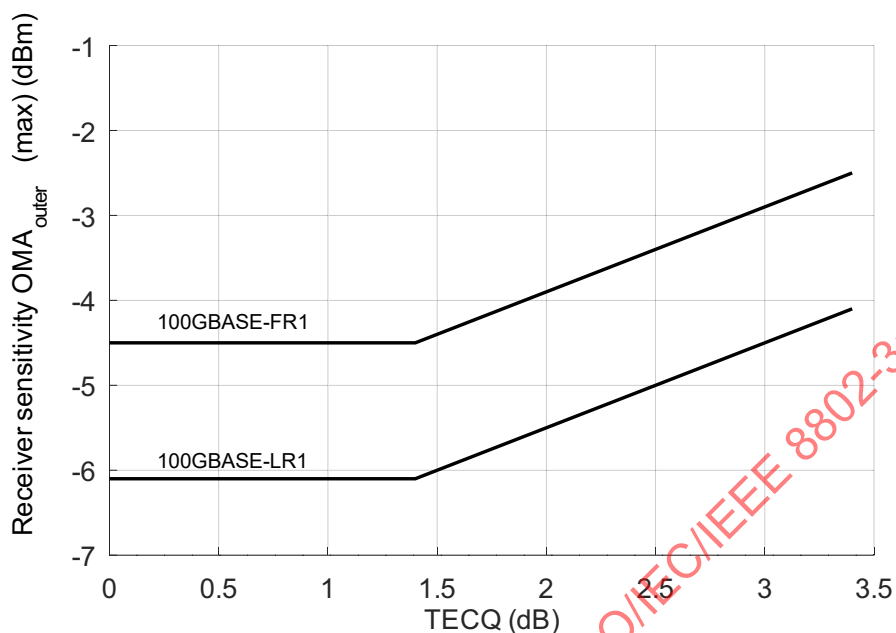

Figure 140-2b—Receiver sensitivity (OMA_{outer}) (max) for 100GBASE-FR1 and 100GBASE-LR1

Change the title and content of 140.6.3 as follows:

140.6.3 100GBASE-DR, 100GBASE-FR1, and 100GBASE-LR1 illustrative link power budgets

An illustrative illustrative power budgets and penalties for 100GBASE-DR, 100GBASE-FR1, and 100GBASE-LR1 channels are shown in Table 140-8.

Table 140–8—100GBASE-DR, 100GBASE-FR1, and 100GBASE-LR1 illustrative link power budgets

Parameter	Value 100GBASE-DR	100GBASE-FR1	100GBASE-LR1	Unit
Power budget (for max TDECQ):	—	7.8	10.6	dB
for extinction ratio ≥ 5 dB	6.5	—	—	dB
for extinction ratio < 5 dB	6.8	—	—	dB
Operating distance	500	2 000	10 000	m
Channel insertion loss ^a	See 140.9 ^a	4 ^a	6.3 ^b	dB
Maximum discrete reflectance	–35	–35 ^{c, d}	–35 ^{e, e}	dB
Allocation for penalties ^f (for max TDECQ):	—	3.8	4.3	dB
for extinction ratio ≥ 5 dB	6.5 minus max channel insertion loss per Table 140–12	—	—	dB
for extinction ratio < 5 dB	6.8 minus max channel insertion loss per Table 140–12	—	—	dB
Additional insertion loss allowed	0	0	0	dB

^a The channel insertion losses for 100GBASE-DR and 100GBASE-FR1 are calculated using the maximum distances specified in Table 140–5 and cabled optical fiber attenuation of 0.5 dB/km at 1304.5 nm plus an allocation for connection and splice loss given in 140.10.2.1.

^b The channel insertion loss for 100GBASE-LR1 is calculated using the maximum distance specified in Table 140–5 and fiber attenuation of 0.43 dB/km plus an allocation for connection and splice loss given in 140.10.2.1.

^c See 140.10.2.2 for details and specifications as a function of the number of discrete reflectances within the channel.

^d Maximum value for each discrete reflectance with 4 discrete reflectances above –55 dB within the channel.

^e Maximum value for each discrete reflectance with 6 discrete reflectances above –55 dB within the channel.

^f Link penalties are used for link budget calculations. They are not requirements and are not meant to be tested.

Insert new text, Figure 140–2c, and Figure 140–2d at the end of 140.6.3 as follows:

The values of transmitter OMA_{outer} (max), transmitter OMA_{outer} (min) versus TDECQ, and receiver sensitivity (OMA_{outer}) (max) versus TECQ are illustrated in Figure 140–2c for 100GBASE-FR1 and in Figure 140–2d for 100GBASE-LR1.

IEEE Std 802.3cu-2021
 IEEE Standard for Ethernet—Amendment 11: Physical Layers and Management Parameters for
 100 Gb/s and 400 Gb/s Operation over Single-Mode Fiber at 100 Gb/s per Wavelength

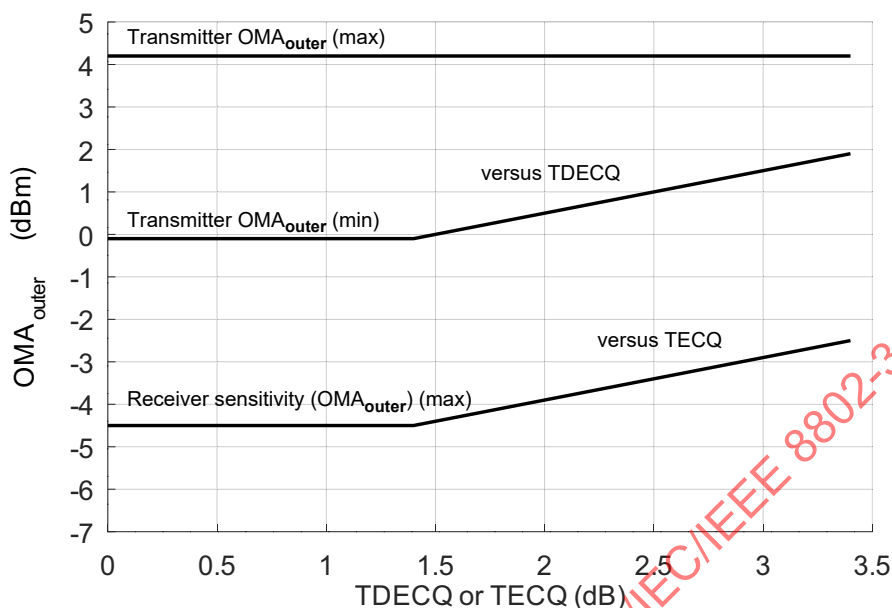

Figure 140-2c—Transmitter OMA_{outer} versus TDECQ and receiver sensitivity (OMA_{outer}) versus TECQ for 100GBASE-FR1

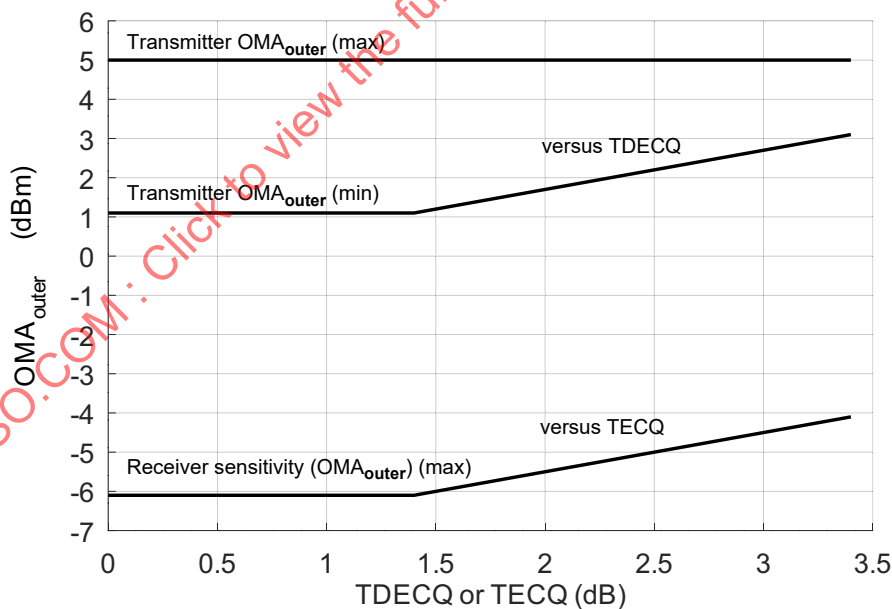

Figure 140-2d—Transmitter OMA_{outer} versus TDECQ and receiver sensitivity (OMA_{outer}) versus TECQ for 100GBASE-LR1

140.7 Definition of optical parameters and measurement methods

140.7.1 Test patterns for optical parameters

Change Table 140–10 as follows:

Table 140–10—Test-pattern definitions and related subclauses

Parameter	Pattern	Related subclause
Wavelength	Square wave, 3, 4, 5, 6 or valid 100GBASE-R signal	140.7.2
Side-mode suppression ratio	3, 5, 6 or valid 100GBASE-R signal	140.7.2
Average optical power	3, 5, 6 or valid 100GBASE-R signal	140.7.3
Outer Optical Modulation Amplitude (OMA _{outer})	4 or 6	140.7.4
Transmitter and dispersion eye closure for PAM4 (TDECQ)	6	140.7.5
Transmitter eye closure for PAM4 (TECQ)	6	140.7.5a
Over/under-shoot	6	140.7.5b
Transmitter power excursion	6	140.7.5c
Extinction ratio	4 or 6	140.7.6
Transmitter transition time	Square wave or 6	140.7.7
RIN _{15.5x} OMA	Square wave	140.7.8
Receiver sensitivity	3 or 5	140.7.9
Stressed receiver conformance test signal calibration	6	140.7.10
Stressed receiver sensitivity	3 or 5	140.7.10

140.7.5 Transmitter and dispersion eye closure for PAM4 (TDECQ)

Change 140.7.5 (as changed by IEEE Std 802.3cn-2020) as follows:

The TDECQ₂ and for 100GBASE-DR only, TDECQ – 10log₁₀(C_{eq}) shall be within the limits given in Table 140–6 if measured using the methods-test setup specified in 121.8.5.1, 121.8.5.2, and with an optical channel specified in 140.7.5.2, using the measurement method specified in 121.8.5.3, and using a reference equalizer as described in 140.7.5.1, with the following exceptions:

- The optical return loss of the transmitter compliance channel is 15.5 dB.
- The signaling rate of the test pattern generator is as given in Table 140–6 and uses a test pattern specified for TDECQ in Table 140–10.
- There are no interfering optical lanes and therefore the delay requirement of at least 31 UI between test pattern on one lane and any other lane, as specified in 121.8.5.1, is redundant.
- The combination of the O/E converter and the oscilloscope has a 3 dB bandwidth of approximately 26.5625 GHz with a fourth-order Bessel-Thomson response to at least 1.3 × 53.125 GHz and at

frequencies above 1.3×53.125 GHz the response should not exceed -20 dB. Compensation may be made for any deviation from an ideal fourth-order Bessel-Thomson response.

- The normalized noise power density spectrum, $N(f)$ in Equation (121-9), is equivalent to white noise filtered by a fourth-order Bessel-Thomson response filter with a bandwidth of 26.5625 GHz.

140.7.5.1 TDECQ reference equalizer

Change the first sentence of 140.7.5.1 as follows:

The reference equalizer for 100GBASE-DR is a 5 tap, T spaced, feed-forward equalizer (FFE), where T is the symbol period.

Insert new subclause 140.7.5.2 after 140.7.5.1 as follows:

140.7.5.2 Channel requirements

The transmitter is tested using an optical channel that meets the requirements in Table 140-10a.

Table 140-10a—Transmitter compliance channel specifications

PMD type	Dispersion ^a (ps/nm)		Insertion loss ^b	Optical return loss ^c	Max mean DGD
	Minimum	Maximum			
100GBASE-DR	$0.011625 \times \lambda \times [1 - (1324 / \lambda)^4]$	$0.011625 \times \lambda \times [1 - (1300 / \lambda)^4]$	Minimum	15.5 dB	0.5 ps
100GBASE-FR1	$0.046 \times \lambda \times [1 - (1324 / \lambda)^4]$	$0.046 \times \lambda \times [1 - (1300 / \lambda)^4]$	Minimum	17.1 dB	0.8 ps
100GBASE-LR1	$0.230 \times \lambda \times [1 - (1324 / \lambda)^4]$	$0.230 \times \lambda \times [1 - (1300 / \lambda)^4]$	Minimum	15.6 dB	0.8 ps

^a The dispersion is measured for the wavelength of the transmitter under test (λ in nm). The coefficient assumes 500 m for 100GBASE-DR, 2 km for 100GBASE-FR1, and 10 km for 100GBASE-LR1.

^b There is no intent to stress the sensitivity of the O/E converter associated with the oscilloscope.

^c The optical return loss is applied at TP2.

A 100GBASE-DR, 100GBASE-FR1, or 100GBASE-LR1 transmitter is to be compliant with a total dispersion at least as negative as the “minimum dispersion” and at least as positive as the “maximum dispersion” columns specified in Table 140-10a for the wavelength of the transmitter under test. This may be achieved with channels consisting of fibers with lengths chosen to meet the dispersion requirements.

To verify that the fiber has the correct amount of dispersion, the measurement method defined in IEC 60793-1-42 may be used. The measurement is made in the linear power regime of the fiber.

The channel provides an optical return loss specified in Table 140-10a. The state of polarization of the back reflection is adjusted to create the greatest RIN.

The mean DGD of the channel is to be less than the value specified in Table 140-10a.

Insert new subclauses 140.7.5a, 140.7.5b, and 140.7.5c after 140.7.5 as follows:

140.7.5a Transmitter eye closure for PAM4 (TECQ)

The transmitter eye closure for PAM4 (TECQ) is a measure of the optical transmitter’s eye closure at TP2. TECQ shall be within the limits given in Table 140-6 for 100GBASE-FR1 and 100GBASE-LR1 if

measured using a test pattern specified for TECQ in Table 140–10. TECQ is measured using the methods specified for TDECQ in 140.7.5, except that the test fiber is not used.

140.7.5b Over/under-shoot

The over/under-shoot shall be within the limits given in Table 140–6 for 100GBASE-FR1 and 100GBASE-LR1 if measured using a test pattern specified for over/under-shoot in Table 140–10.

Over/under-shoot is measured using the waveforms captured for the TDECQ test (see 140.7.5) and the waveform captured for the TECQ test (see 140.7.5a), but without the reference equalizer being applied in either case.

Overshoot is defined as the maximum power above the level three power and relative to the OMA_{outer} according to:

$$\text{Overshoot} = (P_{max} - P_3) / (OMA_{outer}) \times 100$$

Undershoot is defined as the minimum power from the transmitter (P_{min}) below the level zero power and relative to the OMA_{outer} according to:

$$\text{Undershoot} = (P_0 - P_{min}) / (OMA_{outer}) \times 100$$

where

- P_{max} is based on a 10^{-2} hit ratio, where P_{max} is the smallest power level that results in the number of samples above that level not exceeding the product of hit ratio and total number of observed samples, with all samples acquired in a single unit interval eye diagram.
- P_{min} is based on a 10^{-2} hit ratio, where P_{min} is the largest power level that results in the number of samples below that level not exceeding the product of hit ratio and total number of observed samples, with all samples acquired in a single unit interval eye diagram.
- P_3 is the power of the PAM4 level three defined in 122.8.4.
- P_0 is the power of the PAM4 level zero defined in 122.8.4.
- OMA_{outer} is the outer optical modulation amplitude defined in 122.8.4.

140.7.5c Transmitter power excursion

The transmitter power excursion shall be within the limits given in Table 140–6 for 100GBASE-FR1 and 100GBASE-LR1 if measured using a test pattern specified for transmitter power excursion in Table 140–10.

Transmitter power excursion is measured using the waveforms captured for the TECQ test (see 140.7.5a), but without the reference equalizer being applied. Transmitter power excursion is defined as:

$$\text{Transmitter power excursion} = \max (P_{max} - P_{average}, P_{average} - P_{min})$$

where

- P_{max} and P_{min} are defined in 140.7.5b
- $P_{average}$ is the average optical power defined in 140.7.3

Change the title and text of 140.7.8 as follows:

140.7.8 Relative intensity noise (RIN_{45.5x}OMA)

RIN shall be as defined by the measurement methodology of 52.9.6 with the following exceptions:

- a) The optical return loss is ~~45.5x~~ dB, where x is the optical return loss tolerance (max) in Table 140-6.
- b) The upper -3 dB limit of the measurement apparatus is to be approximately equal to the signaling rate (i.e., 53.2 GHz).

140.7.9 Receiver sensitivity

Insert a new subclause heading 140.7.9.1 to contain the existing text and Figure 140-5 from 140.7.9 as follows:

140.7.9.1 Receiver sensitivity for 100GBASE-DR

Change the text of 140.7.9.1 (formerly the text of 140.7.9) as follows (Figure 140-5 remains unchanged):

The Receiver sensitivity for 100GBASE-DR is informative and is defined for a transmitter with a value of SECQ up to 3.4 dB. Receiver sensitivity for 100GBASE-DR should meet Equation (140-1), which is illustrated in Figure 140-5. The normative requirement for the 100GBASE-DR receiver is stressed receiver sensitivity.

$$RS = \max(-3.9, SECQ - 5.3) \quad (\text{dBm}) \quad (140-1)$$

where

RS is the receiver sensitivity
 $SECQ$ is the SECQ of the transmitter used to measure the receiver sensitivity

~~The normative requirement for receivers is stressed receiver sensitivity.~~

Insert new subclause 140.7.9.2 after 140.7.9.1 as follows:

140.7.9.2 Receiver sensitivity for 100GBASE-FR1 and 100GBASE-LR1

The receiver sensitivity (OMA_{outer}) for 100GBASE-FR1 and 100GBASE-LR1 shall be within the limits given in Table 140-7 if measured using a test pattern for receiver sensitivity in Table 140-10.

The conformance test signal at TP3 meets the requirements for a 100GBASE-FR1 or 100GBASE-LR1 transmitter followed by an attenuator.

The TECQ of the conformance test signal is measured according to 140.7.5, except that the test fiber is not used. The measured value of TECQ is then used to calculate the limit for receiver sensitivity (OMA_{outer}) as specified in Table 140-7.

140.7.10 Stressed receiver sensitivity

Change 140.7.10 (as changed by IEEE Std 802.3cn-2020) as follows:

Stressed receiver sensitivity shall be within the limits given in Table 140–7 if measured using the method defined in 121.8.9, using the test pattern specified for SRS in Table 140–10, with the following exceptions:

- The SECQ of the stressed receiver conformance test signal is measured according to 140.7.5, except that the test fiber is not used. The transition time of the stressed receiver conformance test signal is no greater than the value specified in Table 140–6.
- With the Gaussian noise generator on and the sinusoidal jitter and sinusoidal interferer turned off, the $RIN_{15.5x}$ OMA of the SRS test source (where x is the value for optical return loss tolerance from Table 140–6) should be no greater than the value specified in Table 140–6.
- An example stressed receiver conformance test setup is shown in Figure 139–7; however, alternative test setups that generate equivalent stress conditions may be used.
- The signaling rate of the test pattern generator and the extinction ratio of the E/O converter are as given in Table 140–6 using test patterns specified in Table 140–10.
- For 100GBASE-FR1 and 100GBASE-LR1 the values of over/under-shoot and transmitter power excursion of the stressed receiver conformance test signal are within the limits specified in Table 140–6.
- The required values of the “Stressed receiver sensitivity (OMA_{outer}) (max)”, “Stressed eye closure for PAM4 (SECQ)”, and for 100GBASE-DR only, “SECQ - $10\log_{10}(C_{eq})$ (max)” are as given in Table 140–7.

140.8 Safety, installation, environment, and labeling

140.8.2 Laser safety

Change the first paragraph of 140.8.2 as follows:

100GBASE-DR, 100GBASE-FR1, and 100GBASE-LR1 optical transceivers shall conform to Hazard Level 1 laser requirements as defined in IEC 60825-1 and IEC 60825-2, under any condition of operation. This includes single fault conditions whether coupled into a fiber or out of an open bore.

140.8.4 Environment

Change the first paragraph of 140.8.4 as follows:

Normative specifications in this clause shall be met by a system integrating a 100GBASE-DR, 100GBASE-FR1, or 100GBASE-LR1 PMD over the life of the product while the product operates within the manufacturer’s range of environmental, power, and other specifications.

140.8.5 Electromagnetic emission

Change 140.8.5 as follows:

A system integrating a 100GBASE-DR, 100GBASE-FR1, or 100GBASE-LR1 PMD shall comply with applicable local and national codes for the limitation of electromagnetic interference.

140.9 Fiber optic cabling model*Change Table 140–11 as follows:***Table 140–11—Fiber optic cabling (channel) characteristics**

Description	100GBASE-DR	100GBASE-FR1	100GBASE-LR1	Unit
Operating distance (max)	500	<u>2 000</u>	<u>10 000</u>	m
Channel insertion loss ^{a, b} (max)	See Table 140–12	<u>4</u>	<u>6.3</u>	dB
Channel insertion loss (min)	0	<u>0</u>	<u>0</u>	dB
Positive dispersion ^b (max)	0.8	<u>3.2</u>	<u>16</u>	ps/nm
Negative dispersion ^b (min)	–0.93	<u>–3.7</u>	<u>–18.6</u>	ps/nm
DGD_max ^c	2.24	<u>2.3</u>	<u>2</u>	ps
Optical return loss (min)	27	<u>25</u>	<u>22</u>	dB

^a These channel insertion loss values include cable, connectors, and splices.^b Over the wavelength range 1304.5 nm to 1317.5 nm^c Differential Group Delay (DGD) is the time difference at reception between the fractions of a pulse that were transmitted in the two principal states of polarization of an optical signal. DGD_max is the maximum differential group delay that the system ~~must~~ is required to tolerate.*Change the title of Table 140–12 as follows:***Table 140–12—100GBASE-DR ~~M~~ maximum channel insertion loss versus number of discrete reflectances****140.10 Characteristics of the fiber optic cabling (channel)***Change 140.10 as follows:*

The 100GBASE-DR, 100GBASE-FR1, or 100GBASE-LR1 fiber optic cabling shall meet the specifications defined in Table 140–13. The fiber optic cabling consists of one or more sections of fiber optic cable and any intermediate connections required to connect sections together.

140.10.1 Optical fiber cable

Change Table 140–13 as follows:

Table 140–13—Optical fiber and cable characteristics

Description	Value	Unit
Nominal fiber specification wavelength	1310	nm
Cabled optical fiber attenuation (max)	0.43 ^a or 0.5 ^b	dB/km
Zero dispersion wavelength (λ_0)	$1300 \leq \lambda_0 \leq 1324$	nm
Dispersion slope (max) (S_0)	0.093	ps/nm ² km

^a The 0.43 dB/km at 1304.5 nm attenuation for optical fiber cables is derived from Appendix I of ITU-T G.695.

^b The 0.5 dB/km attenuation is provided for Outside Plant cable as defined in ANSI/TIA 568-C3. Using 0.5 dB/km may not support operation over 10 km for 100GBASE-LR1.

140.10.2 Optical fiber connection

140.10.2.1 Connection insertion loss

Change 140.10.2.1 as follows:

For 100GBASE-DR, the maximum link distance is based on an allocation of 2.75 dB total connection and splice loss. For example, this allocation supports five connections with an average insertion loss per connection of 0.5 dB. Connections with different loss characteristics may be used provided the requirements of Table 140–11 are met.

For 100GBASE-FR1, the maximum link distance is based on an allocation of 3 dB total connection and splice loss. For example, this allocation supports six connections with an average insertion loss per connection of 0.5 dB. Connections with different loss characteristics may be used provided the requirements of Table 140–11 are met.

For 100GBASE-LR1, the maximum link distance is based on an allocation of 2 dB total connection and splice loss. For example, this allocation supports four connections with an average insertion loss per connection of 0.5 dB. Connections with different loss characteristics may be used provided the requirements of Table 140–11 are met.

140.10.2.2 Maximum discrete reflectance

Change 140.10.2.2 as follows:

For 100GBASE-DR, the maximum discrete reflectance shall be less or equal than –35 dB. The number of maximum discrete reflectances in the ranges, > –45 dB and ≤ –35 dB, and, > –55 dB and ≤ –45 dB, is limited to the numbers given in Table 140–12 in relation to the maximum channel insertion loss.

For 100GBASE-FR1 and 100GBASE-LR1, the maximum value for each discrete reflectance shall be less than or equal to the value shown in Table 140–14 corresponding to the number of discrete reflectances above –55 dB within the channel. For numbers of discrete reflectances in between two numbers shown in the table, the lower of the two corresponding maximum discrete reflectance values applies.

Insert new Table 140–14 at the end of 140.10.2.2

Table 140–14—Maximum value of each discrete reflectance

Number of discrete reflectances above –55 dB	Maximum value for each discrete reflectance		Unit
	100GBASE-FR1	100GBASE-LR1	
1	–25	–22	dB
2	–31	–29	dB
4	–35	–33	dB
6	–38	–35	dB
8	–40	–37	dB
10	–41	–39	dB

140.10.3 Medium Dependent Interface (MDI)

Change 140.10.3 as follows:

The 100GBASE-DR, 100GBASE-FR1, or 100GBASE-LR1 PMD is coupled to the fiber optic cabling at the MDI. The MDI is the interface between the PMD and the “fiber optic cabling” (as shown in Figure 140–6). Examples of an MDI include the following:

- a) Connectorized fiber pigtail
- b) PMD receptacle

For 100GBASE-DR, when the MDI is a connector plug and receptacle connection, it shall meet the interface performance specifications of IEC 61753-1-1 and IEC 61753-021-2. For 100GBASE-FR1 and 100GBASE-LR1, when the MDI is a connector plug and receptacle connection, it shall meet the interface performance specifications of IEC 61753-1 and IEC 61753-021-2.

NOTE—Transmitter compliance testing is performed at TP2 as defined in 140.5.1, not at the MDI.

Insert new subclause 140.10a after 140.10 as follows:

140.10a Interoperation between 100GBASE-DR, 100GBASE-FR1, and 100GBASE-LR1

The 100GBASE-DR, 100GBASE-FR1, and 100GBASE-LR1 PMDs can interoperate with each other as described here.

140.10a.1 Interoperation between 100GBASE-FR1 and 100GBASE-DR

The 100GBASE-FR1 and 100GBASE-DR PMDs can interoperate with each other provided that the fiber optic cabling (channel) characteristics for 100GBASE-DR (see 140.10 and Table 140–12) are met and the 100GBASE-FR1 transmitter average power is greater than or equal to the value for average launch power (min) for 100GBASE-DR in Table 140–6.

140.10a.2 Interoperation between 100GBASE-LR1 and 100GBASE-DR

The 100GBASE-LR1 and 100GBASE-DR PMDs can interoperate with each other provided that the fiber optic cabling (channel) characteristics for 100GBASE-DR (see 140.10 and Table 140–12) are met, with the exception of the maximum and minimum channel insertion loss values, which are given in Table 140–15 for the two link directions separately. Attenuators may be used to achieve the required losses.

Table 140–15—Channel insertion loss for interoperation between 100GBASE-LR1 and 100GBASE-DR

Direction	Min loss	Max loss	Unit
100GBASE-LR1 transmitter to 100GBASE-DR receiver	0.8	4	dB
100GBASE-DR transmitter to 100GBASE-LR1 receiver	0	5.2	dB

140.10a.3 Interoperation between 100GBASE-LR1 and 100GBASE-FR1

The 100GBASE-LR1 and 100GBASE-FR1 PMDs can interoperate with each other provided that the fiber optic cabling (channel) characteristics for 100GBASE-FR1 (see 140.10) are met, with the exception of the maximum and minimum channel insertion loss values, which are given in Table 140–16 for the two link directions separately. Attenuators may be used to achieve the required losses.

Table 140–16—Channel insertion loss for interoperation between 100GBASE-LR1 and 100GBASE-FR1

Direction	Min loss	Max loss	Unit
100GBASE-LR1 transmitter to 100GBASE-FR1 receiver	0.8	5.2	dB
100GBASE-FR1 transmitter to 100GBASE-LR1 receiver	0	5.1	dB

Change the title of 140.11 as follows:

140.11 Protocol implementation conformance statement (PICS) proforma for Clause 140, Physical Medium Dependent (PMD) sublayer and medium, types 100GBASE-DR, 100GBASE-FR1, and 100GBASE-LR1⁴

140.11.1 Introduction

Change the first paragraph of 140.11.1 as follows:

The supplier of a protocol implementation that is claimed to conform to Clause 140, Physical Medium Dependent (PMD) sublayer and medium, type 100GBASE-DR, 100GBASE-FR1, and 100GBASE-LR1, shall complete the following protocol implementation conformance statement (PICS) proforma:

140.11.2 Identification

140.11.2.2 Protocol summary

Change the table in 140.11.2.2 as follows:

Identification of protocol standard	IEEE Std 802.3cu-2021, Clause 140, Physical Medium Dependent (PMD) sublayer and medium, type 100GBASE-DR, 100GBASE-FR1, and 100GBASE-LR1
Identification of amendments and corrigenda to this PICS proforma that have been completed as part of this PICS	
Have any Exception items been required? No <input type="checkbox"/> Yes <input type="checkbox"/> (See Clause 21; the answer Yes means that the implementation does not conform to IEEE Std 802.3cu-2021.)	
Date of Statement	

⁴Copyright release for PICS proformas: Users of this standard may freely reproduce the PICS proforma in this subclause so that it can be used for its intended purpose and may further publish the completed PICS.

140.11.3 Major capabilities/options

*Insert new rows for items *DR, *FR1, and *LR1 at the top of the table in 140.11.3 as follows (unchanged rows not shown):*

Item	Feature	Subclause	Value/Comment	Status	Support
*DR	100GBASE-DR	140.6	Device supports requirements for 100GBASE-DR PHY	O.1	Yes [<input type="checkbox"/> No [<input type="checkbox"/>
*FR1	100GBASE-FR1	140.6	Device supports requirements for 100GBASE-FR1 PHY	O.1	Yes [<input type="checkbox"/> No [<input type="checkbox"/>
*LR1	100GBASE-LR1	140.6	Device supports requirements for 100GBASE-LR1 PHY	O.1	Yes [<input type="checkbox"/> No [<input type="checkbox"/>
...					

Change the title of 140.11.4 as follows:

140.11.4 PICS proforma tables for Physical Medium Dependent (PMD) sublayer and medium, type 100GBASE-DR, 100GBASE-FR1, and 100GBASE-LR1

140.11.4.3 PMD to MDI optical specifications for 100GBASE-DR

Change the table in 140.11.4.3 as follows:

Item	Feature	Subclause	Value/Comment	Status	Support
DR1	Transmitter meets specifications in Table 140-6	140.6.1	Per definitions in 140.7	<u>DR</u> :M	Yes [<input type="checkbox"/> N/A [<input type="checkbox"/>
DR2	Receiver meets specifications in Table 140-7	140.6.2	Per definitions in 140.7	<u>DR</u> :M	Yes [<input type="checkbox"/> N/A [<input type="checkbox"/>

Insert new subclauses 140.11.4.3a and 140.11.4.3b after 140.11.4.3 as follows:

140.11.4.3a PMD to MDI optical specifications for 100GBASE-FR1

Item	Feature	Subclause	Value/Comment	Status	Support
FR1	Transmitter meets specifications in Table 140-6	140.6.1	Per definitions in 140.7	FR1:M	Yes [<input type="checkbox"/> N/A [<input type="checkbox"/>
FR2	Receiver meets specifications in Table 140-7	140.6.2	Per definitions in 140.7	FR1:M	Yes [<input type="checkbox"/> N/A [<input type="checkbox"/>

140.11.4.3b PMD to MDI optical specifications for 100GBASE-LR1

Item	Feature	Subclause	Value/Comment	Status	Support
LR1	Transmitter meets specifications in Table 140–6	140.6.1	Per definitions in 140.7	LR1:M	Yes [] N/A []
LR2	Receiver meets specifications in Table 140–7	140.6.2	Per definitions in 140.7	LR1:M	Yes [] N/A []

140.11.4.4 Optical measurement methods

Insert new rows for items OM5a, OM5b, and OM5c after the row for item OM5 in the table in 140.11.4.4 as follows (unchanged rows not shown):

Item	Feature	Subclause	Value/Comment	Status	Support
...					
OM5a	Transmitter eye closure for PAM4 (TECQ)	140.7.5a		FR1:M LR1:M	Yes [] N/A []
OM5b	Over/under-shoot	140.7.5b		FR1:M LR1:M	Yes [] N/A []
OM5c	Transmitter power excursion	140.7.5c		FR1:M LR1:M	Yes [] N/A []
...					

Change the row for item OM8 and insert a new row for item OM8a below it in the table in 140.11.4.4 as follows (unchanged rows not shown):

Item	Feature	Subclause	Value/Comment	Status	Support
...					
OM8	RIN₁₃₃OMA measurement procedure Relative intensity noise	140.7.8		M	Yes []
OM8a	Receiver sensitivity	140.7.9		FR1:M LR1:M	Yes [] N/A []
...					

Change the title and content of 140.11.4.6 as follows:

140.11.4.6 Characteristics of the fiber optic cabling and ~~MDI~~ MDI

Item	Feature	Subclause	Value/Comment	Status	Support
OC1	Fiber optic cabling	140.10	Meets requirements specified in Table 140–11	INS:M	Yes [] N/A []
OC2	Maximum discrete reflectance	140.10.2.2	Meets requirements specified in Table 140–12 <u>140.10.2.2</u>	INS:M	Yes [] N/A []
<u>OC3</u>	<u>MDI Requirements</u>	<u>140.10.3</u>	<u>Meets IEC 61753-1 and IEC 61753-021-2</u>	<u>FR1:M</u> <u>LR1:M</u>	<u>Yes []</u> <u>N/A []</u>

STANDARDSISO.COM : Click to view the full PDF of ISO/IEC/IEEE 8802-3:2021/Amd 11:2022

Insert new Clause 151 in numeric order as follows:

151. Physical Medium Dependent (PMD) sublayer and medium, type 400GBASE-FR4 and 400GBASE-LR4-6

151.1 Overview

This clause specifies the 400GBASE-FR4 and the 400GBASE-LR4-6 PMDs together with the single-mode fiber medium. The optical signals generated by these two PMD types are modulated using a 4-level pulse amplitude modulation (PAM4) format. When forming a complete Physical Layer, a PMD shall be connected to the appropriate PMA as shown in Table 151–1 to the medium through the MDI and optionally with the management functions that may be accessible through the management interface defined in Clause 45, or equivalent.

Table 151–1—Physical Layer clauses associated with the 400GBASE-FR4 and 400GBASE-LR4-6 PMDs

Associated clause	400GBASE-FR4, 400GBASE-LR4-6
117—RS	Required
117—400GMII ^a	Optional
118—400GMII Extender	Optional
119—PCS for 400GBASE-R	Required
120—PMA for 400GBASE-R	Required
120B—400GAUI-16 C2C	Optional
120C—400GAUI-16 C2M	Optional
120D—400GAUI-8 C2C	Optional
120E—400GAUI-8 C2M	Optional
78—Energy-Efficient Ethernet	Optional

^aThe 400GMII is an optional interface. However, if the 400GMII is not implemented, a conforming implementation behaves functionally as though the RS and 400GMII were present.

Figure 151–1 shows the relationship of the PMD and MDI (shown shaded) with other sublayers to the ISO/IEC Open System Interconnection (OSI) reference model. 400 Gb/s Ethernet is introduced in Clause 116 and the purpose of each PHY sublayer is summarized in 116.2.

400GBASE-FR4 and 400GBASE-LR4-6 PHYs with the optional Energy-Efficient Ethernet (EEE) fast wake capability may enter the Low Power Idle (LPI) mode to conserve energy during periods of low link utilization (see Clause 78). The deep sleep mode of EEE is not supported.

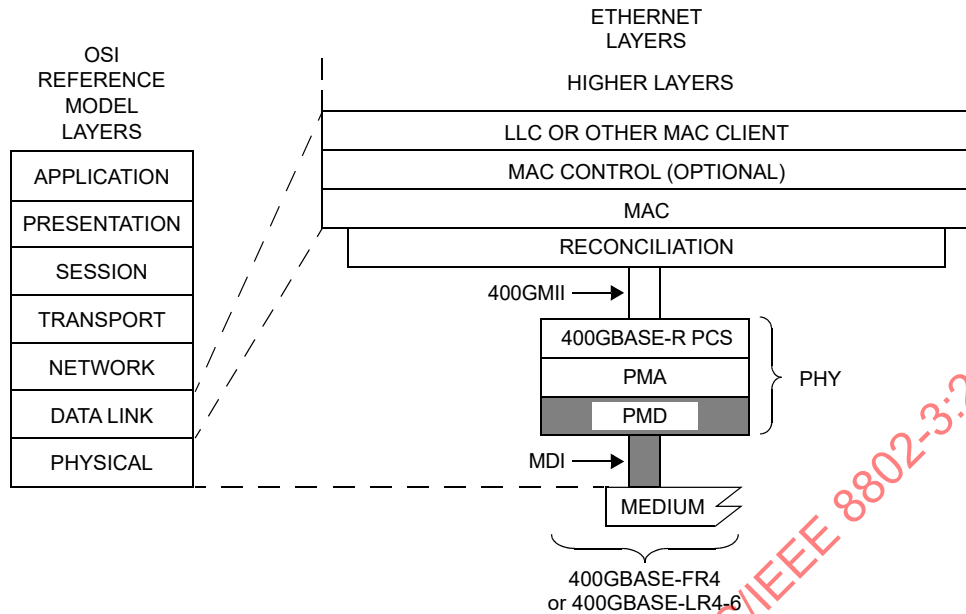

400GMII = 400 Gb/s MEDIA INDEPENDENT INTERFACE
 LLC = LOGICAL LINK CONTROL
 MAC = MEDIA ACCESS CONTROL
 MDI = MEDIUM DEPENDENT INTERFACE
 PCS = PHYSICAL CODING SUBLAYER

PHY = PHYSICAL LAYER DEVICE
 PMA = PHYSICAL MEDIUM ATTACHMENT
 PMD = PHYSICAL MEDIUM DEPENDENT
 FR4 = PMD FOR SINGLE-MODE FIBER — 2 km
 LR4-6 = PMD FOR SINGLE-MODE FIBER — 6 km

Figure 151-1—400GBASE-FR4 and 400GBASE-LR4-6 PMDs relationship to the ISO/IEC Open Systems Interconnection (OSI) reference model and IEEE 802.3 Ethernet model

151.1.1 Bit error ratio

The bit error ratio (BER) when processed according to Clause 120 shall be less than 2.4×10^{-4} provided that the error statistics are sufficiently random that this results in a frame loss ratio (see 1.4.275) of less than 1.7×10^{-12} for 64-octet frames with minimum interpacket gap when processed according to Clause 120 and then Clause 119. For a complete Physical Layer, the frame loss ratio may be degraded to 6.2×10^{-11} for 64-octet frames with minimum interpacket gap due to additional errors from the electrical interfaces.

If the error statistics are not sufficiently random to meet this requirement, then the BER shall be less than that required to give a frame loss ratio of less than 1.7×10^{-12} for 64-octet frames with minimum interpacket gap.

151.2 Physical Medium Dependent (PMD) service interface

This subclause specifies the services provided by the 400GBASE-FR4 and 400GBASE-LR4-6 PMDs. The service interfaces for these PMDs are described in an abstract manner and do not imply any particular implementation. The PMD service interface supports the exchange of encoded data between the PMA entity that resides just above the PMD, and the PMD entity. The PMD translates the encoded data to and from signals suitable for the specified medium.

The PMD service interface is an instance of the inter-sublayer service interface defined in 116.3. The PMD service interface primitives are summarized as follows:

```
PMD:IS_UNITDATA_i.request
PMD:IS_UNITDATA_i.indication
PMD:IS_SIGNAL.indication
```

In the transmit direction, the PMA continuously sends four parallel symbol streams to the PMD, one per lane, each at a nominal signaling rate of 53.125 GBd. The PMD then converts these streams of data units into the appropriate signals on the MDI.

In the receive direction, the PMD continuously sends four parallel symbol streams to the PMA corresponding to the signals received from the MDI, one per lane, each at a nominal signaling rate of 53.125 GBd.

The SIGNAL_DETECT parameter defined in this clause maps to the SIGNAL_OK parameter in the PMD:IS_SIGNAL.indication(SIGNAL_OK) inter-sublayer service interface primitive defined in 116.3.

The SIGNAL_DETECT parameter can take on one of two values: OK or FAIL. When SIGNAL_DETECT = FAIL, the rx_symbol parameters are undefined.

NOTE—SIGNAL_DETECT = OK does not guarantee that the rx_symbol parameters are known to be good. It is possible for a poor quality link to provide sufficient light for a SIGNAL_DETECT = OK indication and still not meet the BER defined in 151.1.1.

151.3 Delay and Skew

151.3.1 Delay constraints

The sum of the transmit and receive delays at one end of the link contributed by the 400GBASE-FR4 or 400GBASE-LR4-6 PMD including 2 m of fiber in one direction shall be no more than 8192 bit times (16 pause_quanta or 20.48 ns). A description of overall system delay constraints and the definitions for bit times and pause_quanta can be found in 116.4 and its references.

151.3.2 Skew constraints

The Skew (relative delay between the lanes) and Skew Variation are kept within limits so that the information on the lanes can be reassembled by the PCS. Skew and Skew Variation are defined in 116.5 and specified at the points SP1 to SP6 shown in Figure 116-4 and Figure 116-5.

If the PMD service interface is physically instantiated so that the Skew at SP2 can be measured, then the Skew at SP2 is limited to 43 ns and the Skew Variation at SP2 is limited to 400 ps.

The Skew at SP3 (the transmitter MDI) shall be less than 54 ns and the Skew Variation at SP3 shall be less than 600 ps.

The Skew at SP4 (the receiver MDI) shall be less than 134 ns and the Skew Variation at SP4 shall be less than 3.4 ns.

If the PMD service interface is physically instantiated so that the Skew at SP5 can be measured, then the Skew at SP5 shall be less than 145 ns and the Skew Variation at SP5 shall be less than 3.6 ns.

For more information on Skew and Skew Variation see 116.5. The measurements of Skew and Skew Variation are defined in 87.8.2.

151.4 PMD MDIO function mapping

The optional MDIO capability described in Clause 45 defines several variables that may provide control and status information for and about the PMD. If the MDIO interface is implemented, the mapping of MDIO control variables to PMD control variables shall be as shown in Table 151–2 and the mapping of MDIO status variables to PMD status variables shall be as shown in Table 151–3.

Table 151–2—MDIO/PMD control variable mapping

MDIO control variable	PMA/PMD register name	Register/bit number	PMD control variable
Reset	PMA/PMD control 1 register	1.0.15	PMD_reset
Global PMD transmit disable	PMD transmit disable register	1.9.0	PMD_global_transmit_disable
PMD transmit disable 3 to PMD transmit disable 0	PMD transmit disable register	1.9.4 to 1.9.1	PMD_transmit_disable_3 to PMD_transmit_disable_0

Table 151–3—MDIO/PMD status variable mapping

MDIO status variable	PMA/PMD register name	Register/bit number	PMD status variable
Fault	PMA/PMD status 1 register	1.1.7	PMD_fault
Transmit fault	PMA/PMD status 2 register	1.8.11	PMD_transmit_fault
Receive fault	PMA/PMD status 2 register	1.8.10	PMD_receive_fault
Global PMD receive signal detect	PMD receive signal detect register	1.10.0	PMD_global_signal_detect
PMD receive signal detect 3 to PMD receive signal detect 0	PMD receive signal detect register	1.10.4 to 1.10.1	PMD_signal_detect_3 to PMD_signal_detect_0

151.5 PMD functional specifications

The 400GBASE-FR4 and 400GBASE-LR4-6 PMDs perform the Transmit and Receive functions, which convey data between the PMD service interface and the MDI.

151.5.1 PMD block diagram

The PMD block diagram is shown in Figure 151–2. For purposes of system conformance, the PMD sublayer is standardized at the points described in this subclause. The optical transmit signal is defined at the output end of a single-mode fiber patch cord (TP2), between 2 m and 5 m in length. Unless specified otherwise, all transmitter measurements and tests defined in 151.8 are made at TP2. The optical receive signal is defined at the output of the fiber optic cabling (TP3) at the MDI (see 151.11.3). Unless specified otherwise, all receiver measurements and tests defined in 151.8 are made at TP3.

TP1<0:3> and TP4<0:3> are informative reference points that may be useful to implementers for testing components (these test points are not typically accessible in an implemented system).

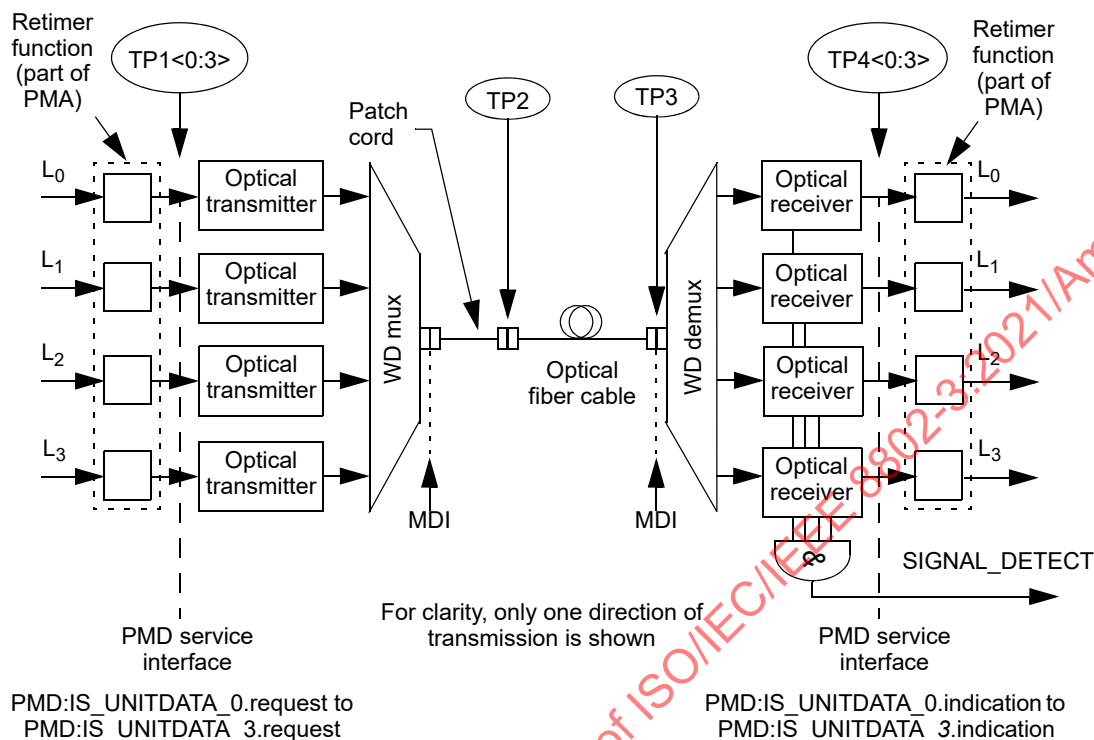

WD = Wavelength division

NOTE—Specification of the retimer function and the electrical implementation of the PMD service interface is beyond the scope of this standard.

Figure 151-2—Block diagram for 400GBASE-FR4 and 400GBASE-LR4-6 transmit/receive paths

151.5.2 PMD transmit function

The PMD Transmit function shall convert the four symbol streams requested by the PMD service interface messages PMD:IS_UNITDATA_0.request to PMD:IS_UNITDATA_3.request into four separate optical signals. The four optical signals shall then be wavelength division multiplexed and delivered to the MDI, all according to the transmit optical specifications in this clause. The highest optical power level in each signal stream shall correspond to tx_symbol = three and the lowest shall correspond to tx_symbol = zero.

151.5.3 PMD receive function

The PMD Receive function shall demultiplex the composite optical signal received from the MDI into four separate optical signals. The four optical signals shall then be converted into four symbol streams for delivery to the PMD service interface using the messages PMD:IS_UNITDATA_0.indication to PMD:IS_UNITDATA_3.indication, all according to the receive optical specifications in this clause. The higher optical power level in each signal shall correspond to rx_symbol = three and the lowest shall correspond to rx_symbol = zero.

151.5.4 PMD global signal detect function

The PMD global signal detect function shall report the state of SIGNAL_DETECT via the PMD service interface. The SIGNAL_DETECT parameter is signaled continuously, while the PMD:IS_SIGNAL.indication message is generated when a change in the value of SIGNAL_DETECT occurs. The SIGNAL_DETECT parameter defined in this clause maps to the SIGNAL_OK parameter in the inter-sublayer service interface primitives defined in 151.2.

SIGNAL_DETECT shall be a global indicator of the presence of optical signals on all four lanes. The value of the SIGNAL_DETECT parameter shall be generated according to the conditions defined in Table 151-4. The PMD receiver is not required to verify whether a compliant 400GBASE-R signal is being received. This standard imposes no response time requirements on the generation of the SIGNAL_DETECT parameter.

Table 151-4—SIGNAL_DETECT value definition

Receive conditions	SIGNAL_DETECT value
For any lane; Average optical power at TP3 \leq -16 dBm	FAIL
For all lanes; [(Optical power at TP3 \geq average receive power, each lane (min) in Table 151-8) AND (compliant 400GBASE-R signal input)]	OK
All other conditions	Unspecified

As an unavoidable consequence of the requirements for the setting of the SIGNAL_DETECT parameter, implementations must provide adequate margin between the input optical power level at which the SIGNAL_DETECT parameter is set to OK, and the inherent noise level of the PMD including the effects of crosstalk, power supply noise, etc.

Various implementations of the Signal Detect function are permitted by this standard, including implementations that generate the SIGNAL_DETECT parameter values in response to the amplitude of the modulation of the optical signal and implementations that respond to the average optical power of the modulated optical signal.

151.5.5 PMD lane-by-lane signal detect function

Various implementations of the Signal Detect function are permitted by this standard. When the MDIO is implemented, each PMD_signal_detect_{*i*}, where *i* represents the lane number in the range 0:3, shall be continuously set in response to the magnitude of the optical signal on its associated lane, according to the requirements of Table 151-4.

151.5.6 PMD reset function

If the MDIO interface is implemented, and if PMD_reset is asserted, the PMD shall be reset as defined in 45.2.1.1.1.

151.5.7 PMD global transmit disable function (optional)

The PMD global transmit disable function is optional and allows all of the optical transmitters to be disabled.

- a) When the `PMD_global_transmit_disable` variable is set to one, this function shall turn off all of the optical transmitters so that each transmitter meets the requirements of the average launch power of the OFF transmitter in Table 151–7.
- b) If a `PMD_fault` is detected, then the PMD may set the `PMD_global_transmit_disable` variable to one, turning off the optical transmitter in each lane.

151.5.8 PMD lane-by-lane transmit disable function

The PMD lane-by-lane transmit disable function allows the optical transmitters in each lane to be selectively disabled.

- a) When a `PMD_transmit_disable_i` variable (where i represents the lane number in the range 0:3 for 400GBASE-FR4 and 400GBASE-LR4-6) is set to one, this function shall turn off the optical transmitter associated with that variable so that the transmitter meets the requirements of the average launch power of the OFF transmitter in Table 151–7.
- b) If a `PMD_fault` is detected, then the PMD may set each `PMD_transmit_disable_i` variable to one, turning off the optical transmitter in each lane.

If the PMD lane-by-lane transmit disable function is not implemented in MDIO, an alternative method shall be provided to independently disable each transmit lane for testing purposes.

151.5.9 PMD fault function (optional)

If the PMD has detected a local fault on any of the transmit or receive paths, the PMD shall set `PMD_fault` to one.

If the MDIO interface is implemented, `PMD_fault` shall be mapped to the fault bit as specified in 45.2.1.2.3.

151.5.10 PMD transmit fault function (optional)

If the PMD has detected a local fault on any transmit lane, the PMD shall set the `PMD_transmit_fault` variable to one.

If the MDIO interface is implemented, `PMD_transmit_fault` shall be mapped to the transmit fault bit as specified in 45.2.1.7.4.

151.5.11 PMD receive fault function (optional)

If the PMD has detected a local fault on any receive lane, the PMD shall set the `PMD_receive_fault` variable to one.

If the MDIO interface is implemented, `PMD_receive_fault` shall be mapped to the receive fault bit as specified in 45.2.1.7.5.

151.6 Wavelength-division-multiplexed lane assignments

The wavelength range for each lane of the 400GBASE-FR4 and 400GBASE-LR4-6 PMDs is defined in Table 151-5. The 400GBASE-FR4 and 400GBASE-LR4-6 center wavelengths are members of the CWDM wavelength grid defined in ITU-T G.694.2 and are spaced at 20 nm.

Table 151-5—400GBASE-FR4 and 400GBASE-LR4-6 wavelength-division-multiplexed lane assignments

Lane	Center wavelength	Wavelength range
L ₀	1271 nm	1264.5 to 1277.5 nm
L ₁	1291 nm	1284.5 to 1297.5 nm
L ₂	1311 nm	1304.5 to 1317.5 nm
L ₃	1331 nm	1324.5 to 1337.5 nm

NOTE—There is no requirement to associate a particular electrical lane with a particular optical lane, as the PCS is capable of receiving lanes in any arrangement.

151.7 PMD to MDI optical specifications for 400GBASE-FR4 and 400GBASE-LR4-6

The operating ranges for the 400GBASE-FR4 and 400GBASE-LR4-6 PMDs are defined in Table 151-6. A 400GBASE-FR4 or 400GBASE-LR4-6 compliant PMD operates on type G.652.B, G.652.D, G.657.A1, or G.657.A2 single-mode fibers according to the specifications defined in Table 151-14. A PMD that exceeds the operating range requirement while meeting all other optical specifications is considered compliant (e.g., a 400GBASE-FR4 PMD operating at 2.5 km meets the operating range requirement of 2 m to 2 km).

The 400GBASE-LR4-6 PMD interoperates with the 400GBASE-FR4 PMD provided that the channel guidelines defined in 151.12 are met.

Table 151-6—400GBASE-FR4 and 400GBASE-LR4-6 operating ranges

PMD type	Required operating range
400GBASE-FR4	2 m to 2 km
400GBASE-LR4-6	2 m to 6 km

151.7.1 400GBASE-FR4 and 400GBASE-LR4-6 transmitter optical specifications

The 400GBASE-FR4 transmitter shall meet the specifications defined in Table 151-7 per the definitions in 151.8. The 400GBASE-LR4-6 transmitter shall meet the specifications defined in Table 151-7 per the definitions in 151.8.

Table 151–7—400GBASE-FR4 and 400GBASE-LR4-6 transmit characteristics

Description	400GBASE-FR4	400GBASE-LR4-6	Unit
Signaling rate, each lane (range)	53.125 ± 100 ppm		GBd
Modulation format	PAM4		—
Lane wavelengths (range)	1264.5 to 1277.5 1284.5 to 1297.5 1304.5 to 1317.5 1324.5 to 1337.5		nm
Side-mode suppression ratio (SMSR), (min)	30		dB
Total average launch power (max)	10.4	11.1	dBm
Average launch power, each lane (max)	4.4	5.1	dBm
Average launch power, each lane ^a (min)	–3.2	–2.7	dBm
Outer Optical Modulation Amplitude (OMA _{outer}), each lane (max)	3.7	4.4	dBm
Outer Optical Modulation Amplitude (OMA _{outer}), each lane (min) for TDECQ < 1.4 dB for 1.4 dB ≤ TDECQ ≤ 3.4 dB	–0.2 –1.6 + TDECQ	0.3 –1.1 + TDECQ	dBm dBm
Difference in launch power between any two lanes (OMA _{outer}) (max)	3.9	4	dB
Transmitter and dispersion eye closure for PAM4 (TDECQ), each lane (max)	3.4	3.4	dB
Transmitter eye closure for PAM4 (TECQ), each lane (max)	3.4	3.4	dB
TDECQ – TECQ (max)	2.5	2.5	dB
Over/under-shoot (max)	22	22	%
Transmitter power excursion (max)	1.8	2.5	dBm
Extinction ratio, each lane (min)	3.5	3.5	dB
Transmitter transition time (max)	17		ps
Average launch power of OFF transmitter, each lane (max)	–16	–16	dBm
RIN _{17.1} OMA (max)	–136	—	dB/Hz
RIN _{15.6} OMA (max)	—	–136	dB/Hz
Optical return loss tolerance (max)	17.1	15.6	dB
Transmitter reflectance ^b (max)	–26		dB

^a Average launch power, each lane (min) is informative and not the principal indicator of signal strength. A transmitter with launch power below this value cannot be compliant; however, a value above this does not ensure compliance.

^b Transmitter reflectance is defined looking into the transmitter.

The values for OMA_{outer} each lane (min) in Table 151–7 vary with TDECQ. The relationships are illustrated in Figure 151–3 along with the values for OMA_{outer} each lane (max).

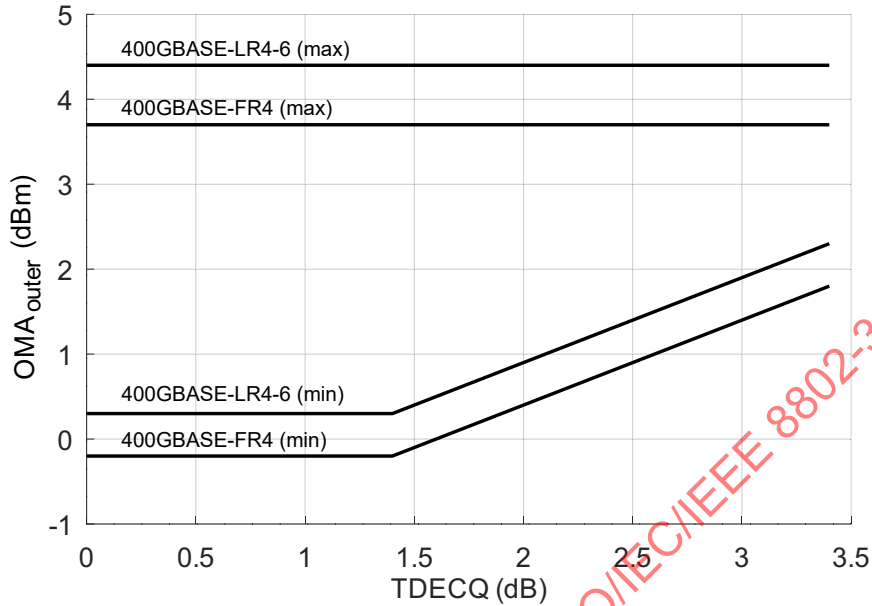

Figure 151-3—OMA_{outer} each lane (max) and OMA_{outer} each lane (min) versus TDECQ for 400GBASE-FR4 and 400GBASE-LR4-6

151.7.2 400GBASE-FR4 and 400GBASE-LR4-6 receive optical specifications

The 400GBASE-FR4 receiver shall meet the specifications in Table 151-8 per the definitions in 151.8. The 400GBASE-LR4-6 receiver shall meet the specifications in Table 151-8 per the definitions in 151.8.